

Decomposed Temporal Dynamic CNN: Efficient Time-Adaptive Network for Text-Independent Speaker Verification Explained with Speaker Activation Map

Seong-Hu Kim, Hyeonuk Nam, Yong-Hwa Park

Department of Mechanical Engineering, Korea Advanced Institute of Science and Technology, Korea
{seonghu.kim, frednam, yhpark}@kaist.ac.kr

Abstract

Temporal dynamic models for text-independent speaker verification extract consistent speaker information regardless of phonemes by using temporal dynamic CNN (TDY-CNN) in which kernels adapt to each time bin. However, TDY-CNN shows limitations that the model is too large and does not guarantee the diversity of adaptive kernels. To address these limitations, we propose *decomposed temporal dynamic CNN (DTDY-CNN)* that makes adaptive kernel by combining static kernel and dynamic residual based on matrix decomposition. The baseline model using DTDY-CNN maintained speaker verification performance while reducing the number of model parameters by 35% compared to the model using TDY-CNN. In addition, detailed behaviors of temporal dynamic models on extraction of speaker information was explained using speaker activation maps (SAM) modified from gradient-weighted class activation mapping (Grad-CAM). In DTDY-CNN, the static kernel activates voiced features of utterances, and the dynamic residual activates unvoiced high-frequency features of phonemes. DTDY-CNN effectively extracts speaker information from not only formant frequencies and harmonics but also detailed unvoiced phonemes' information, thus explaining its outstanding performance on text-independent speaker verification.

Index Terms: speaker verification, text-independent, temporal dynamic model, phoneme-adaptive model, explainable AI

1. Introduction

There are two kinds of speaker verification tasks, depending on whether the text of enrollment and test utterances are the same or not: text-dependent and text-independent. Despite the fact that text-independent speaker verification uses random texts composed of different phoneme sequence and acoustic characteristics, both tasks are mostly solved with the same deep learning models and methodologies. We inferred that conventional text-independent speaker verification methods do not consider the effect of random texts with different phoneme sequence. Previous studies support our interpretation on the limitation of text-independent speaker verification by showing that speaker embedding and performance depend on phonemes [1-3]. Thus, we proposed temporal content-adaptive models that extract consistent speaker information by adapting convolutional neural network (CNN) kernels with the time bins of input utterances [4, 5], and similar studies were conducted recently [6, 7].

Among them, temporal dynamic convolutional neural network (TDY-CNN) [4], applies adaptive kernels by weighted sum of basis kernels, extracting consistent speaker embeddings regardless of phonemes. This result proved the advantage of temporal content-adaptive models that consider

phoneme variations in random texts on text-independent speaker verification. However, generating adaptive kernels using K basis kernels may cause a constraint as adaptive kernels can only have up to K principal components, thus the diversity of adaptive kernels might not be enough to consider all phonemes. Simple solution to this is to use many basis kernels, but the number of model parameters would increase exponentially. In addition, several limitations of dynamic convolution (DY-CNN) [8] such as lack of compactness and challenge in joint optimization of attention weights and basis kernels have been reported. To address these limitations, dynamic convolutional decomposition (DCD) was proposed [9]. DCD replaced dynamic attention weights with dynamic channel fusion matrix based on matrix decomposition. The structure of DCD that fuses features in the latent space instead of applying weighted sum on basis kernels could enhance secure the diversity of adaptive kernels. Thus, we applied DCD on TDY-CNN to address the previous limitations and improve text-independent speaker verification performance.

In addition, to explain how TDY-CNN extracted consistent speaker embeddings regardless of phonemes, an analysis on how kernels adapt to different phonemes was introduced [4]. The result has shown that phoneme groups sharing similar acoustic characteristics use similar adaptive kernels of TDY-CNN. The analysis has deepened our understanding in TDY-CNN, but it does not completely explain how the temporal dynamic model fully utilized adaptive kernels to extract speaker information from utterances with random phoneme sequence. Such problem has been commonly raised against artificial intelligence (AI), so explainable AI (XAI) [10] has been proposed to explain and interpret black-box models including deep learning models. In particular, gradient-weighted class activation mapping (Grad-CAM) [11] is proposed to provide visual explanation on various CNN-based models. To further enhance our understanding in temporal dynamic convolution, we apply Grad-CAM on text-independent speaker verification models and explain whether temporal dynamic models adapt to various phonemes as we aimed to.

In this paper, we propose a *decomposed temporal dynamic convolutional neural network (DTDY-CNN)* for text-independent speaker verification. The two main contributions of this work are as follows:

1. Matrix decomposition is applied to temporal adaptive kernels to ensure that adaptive kernels fully consider all phonemes with higher degree of freedom.
2. We explained how text-independent speaker verification models extract speaker embeddings using the speaker activation map (SAM) modified from Grad-CAM.

The remainder of the paper is organized as follows. Section 2 introduces DTDY-CNN for speaker verification. Section 3

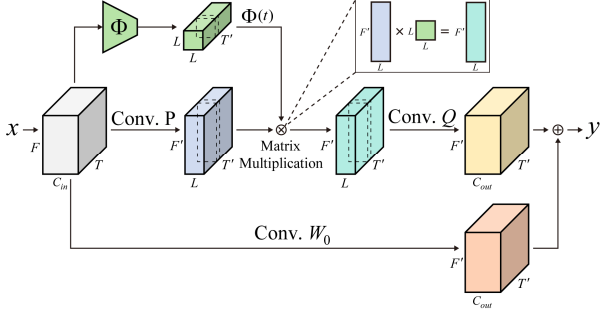

Figure 1: Structure of decomposed temporal dynamic convolution module. It aggregates convolution results of static kernel W_0 and dynamic residual $P\Phi(t)Q$.

describes baseline models and training details with evaluation metrics. Section 4 shows the experiment results and analysis. Finally, Section 5 presents conclusions.

2. Decomposed Temporal Dynamic Convolutional Neural Network

DCD, lighter and more powerful than its preceding work, is designed to adapt one dynamic kernel on single input only. Thus, it needs modification in order to adapt to each time bin of input [8, 9]. Therefore, we propose the decomposed temporal dynamic convolutional neural network (DTDY-CNN) that applies matrix decomposed adaptive convolution depending on time bins as follows to capture speaker information from various utterances more efficiently.

$$y(f, t) = W(t) * x(f, t) \quad (1)$$

$$W(t) = W_0 + P\Phi(t)Q \quad (2)$$

A temporal adaptive kernel $W(t) \in \mathbb{R}^{C_{out} \times C_{in} \times k^2}$ is convoluted with the input $x(f, t) \in \mathbb{R}^{C_{in} \times F \times T}$ and the result is output $y(f, t) \in \mathbb{R}^{C_{out} \times F' \times T'}$, where C_{in} and C_{out} are the numbers of input and output channels, k is kernel size, F and T are feature shapes, respectively. $W(t)$ is composed of static kernel W_0 and dynamic residual $P\Phi(t)Q$. $Q \in \mathbb{R}^{L \times C_{in} \times k^2}$ compresses the input into a lower dimension L so that $Q * x \in \mathbb{R}^{L \times F' \times T'}$. Temporal dynamic matrix $\Phi(t) \in \mathbb{R}^{L \times L}$ is a linear transformation matrix in the L -dimensional latent space, and there are different linear transformations for each time bins T' . The temporal dynamic matrix is obtained by applying two fully-connected layers with Squeeze-and-Excitation [12] to the input flattened along the channel C_{in} and frequency F dimensions. We set latent space dimension L as $\sqrt{C_{in} \times F}$. $P \in \mathbb{R}^{C_{out} \times L}$ expands the dynamically fused result $\Phi(t)Q * x \in \mathbb{R}^{L \times F' \times T'}$ into the output channel dimension C_{out} . DTDY-CNN applies temporal dynamic transformation adaptive to input in the latent space containing major information about speakers.

In DTDY-CNN, we implement the dynamic residual of the temporal adaptive kernel using two CNN layers with a matrix multiplication in between. The convolution output with this residual kernel is added to the convolution output of static kernel as shown in Figure 1. Q and P are equivalent to $k \times k$ and 1×1 2D CNNs, respectively. The temporal dynamic matrix is applied to each time bin using matrix multiplication between Q and P layers. We expect DTDY-CNN to consider phonemes by securing the diversity of adaptive kernels using temporal dynamic matrix in L -dimensional latent space with fewer parameters.

3. Experiment Setup and Details

3.1. Input representations

2-second-long segments are randomly extracted from training utterances. The segments are converted into 64-dimensional log Mel-spectrograms using 25ms hamming window with 10ms step and the number of fast Fourier transform 512. Mean and variance normalization is performed on every frequency bin. The Mel-spectrograms with a size of 64×200 are used for training.

3.2. Baseline architecture and loss

As residual networks have been shown to be effective on speaker recognition, so we use ResNet-34 as a baseline model [13]. The channels of ResNet-34 are reduced to a quarter (ResNet-34($\times 0.25$)) and half (ResNet-34($\times 0.5$)) for computational cost reduction. Frame-level features are aggregated using average pooling to apply uniform attention and backward gradients to each frame-level feature. DTDY-CNN module replaces all convolution modules except for the first convolution layer that extracts global features [8].

Models are trained using a loss function combining the angular prototypical loss with the vanilla softmax loss. This method demonstrates better verification performance than using each or other combinations of the loss functions [14].

3.3. Implementation details and datasets

The models are trained for 300 epochs using the Adam optimizer with weight decay 5×10^{-5} . An initial learning rate is 10^{-3} and it decreases by a factor of 0.75 every 15 epochs. Batch normalization is used with a fixed batch size of 800 consisting of 400 mini-batch from 2 utterances for angular prototypical loss. No data augmentation is performed during training. We use 5994 speakers of Voxceleb2 development set for training [15], and the models are validated on Voxceleb1 test set [16].

3.4. Evaluation metrics

Ten 4-second-long segments are sampled with the same intervals from each test segment, and 100 cosine similarities between every pair of segments are computed. Mean of the 100 similarities is used as the final pairwise score [14, 15]. Based on the average similarity score between speakers, we calculate Equal Error Rate (EER) and the minimum value of the cost function C_{det} with parameters $C_{miss} = 1$, $C_{fa} = 1$, and $P_{target} = 0.05$ [16, 17] as evaluation metrics of verification.

4. Results and Analysis

4.1. Text-independent speaker verification using DTDY-CNN

4.1.1. Reduction ratio of temporal dynamic matrix generator

The temporal dynamic matrix is obtained from the channel and frequency dimension of data using squeeze operation. Reduction ratio r indicates how much speaker information is squeezed, so r is directly related to the model complexity and speaker verification performance.

We experimented the text-independent speaker verification performance of DTDY-ResNet-34(0.25) with different reduction ratios to optimize DTDY-CNN. The models are

Table 1: *Speaker verification performance of decomposed temporal dynamic models with different reduction ratio.*

DTDY-ResNet-34($\times 0.25$)	#Parm	EER (%)	MinDCF
$r = 1/16$	5.69M	1.87	0.141
$r = 1/8$	8.89M	1.80	0.132

Table 2: *Speaker verification performance of the networks without data augmentation.*

Network	#Parm	EER (%)	MinDCF
ResNet-34($\times 0.25$)	1.86M	2.43	0.184
TDY-ResNet-34($\times 0.25$)	13.3M	1.61	0.120
DTDY-ResNet-34($\times 0.25$)	8.89M	1.80	0.132
ResNet-34($\times 0.5$)	6.37M	1.70	0.129
TDY-ResNet-34($\times 0.5$)	51.9M	1.48	0.118
DTDY-ResNet-34($\times 0.5$)	33.6M	1.48	0.110
ResNet-50 [15]	67.0M	3.95	0.429
Thin ResNet-34 [17]	12.4M	2.87	0.310
H/ASP [18]	8.00M	1.21	0.098
ECAPA-TDNN [19]	14.7M	1.18	0.088

tested for two cases ($r = 1/16, 1/8$) as shown in Table 1. When $r = 1/4$, the number of model parameters is 15.5M, which is larger than TDY-CNN applied model with 13.3M parameters. DTDY-ResNet-34($\times 0.25$) with $r = 1/8$ yield the best performance, and the error rate was degraded as $r = 1/16$. While lower reduction ratio reduces computational costs, it compromises the performance by squashing important information (speakers, phonemes, etc.). Thus, we chose DTDY-CNN with $r = 1/8$ as the optimal module for text-independent speaker verification.

4.1.2. Text-independent speaker verification results

The text-independent speaker verification performances are compared between baseline models and temporal dynamic models as shown in Table 2. DTDY-ResNet-34 models perform better speaker verification than ResNet-34 models which use static CNN and show similar performance to TDY-ResNet-34 models. Especially, DTDY-ResNet-34($\times 0.5$) has an EER of 1.48%, which is the best performance on this paper. This is the same performance as TDY-ResNet-34($\times 0.5$) with $K = 6$, but the number of model parameters is reduced by 35.3%. Thus, DTDY-CNN maintains speaker verification performance of models using TDY-CNN with fewer model parameters due to its compact structure based on matrix decomposition.

Temporal dynamic models are also compared to previous studies [15, 17-19] trained with Voxceleb2 without data augmentation and tested with Voxceleb1. DTDY-ResNet-34($\times 0.5$) shows good verification performance with fewer model parameters but still lags behind the state-of-the-art performance.

4.2. Explanation of temporal dynamic models using Grad-CAM

In this section, we use (Grad-CAM) [11] to analyze from which part of utterances the dynamic models extract speaker information. As Grad-CAM produces a coarse localization map for any target using target-specific gradients flowing into the final convolutional layer, it is widely used to explain the behavior of trained deep neural networks.

There are two problems in applying Grad-CAM to speaker verification models: (i) unclear target for speaker verification

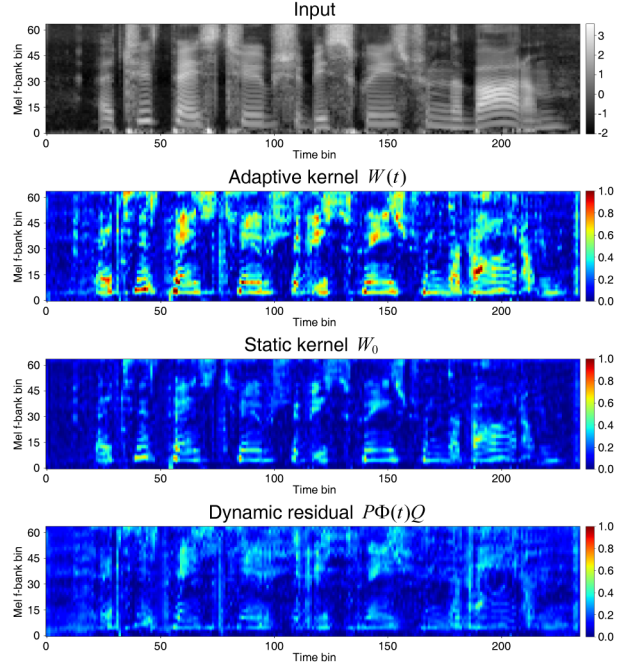

Figure 2: *Speaker activation map of adaptive kernel, static kernel, and dynamic residual of first 6 DTDY-CNN layers in DTDY-ResNet-34($\times 0.25$) for SX429 by FTAJ0.*

network architecture and (ii) inappropriateness of target localization map on speaker verification. For (i), speaker verification models do not explicitly perform classification task; they rather extract speaker embeddings to compare and verify the speaker information. It is difficult to clearly define the target of speaker verification models from which we calculate the gradients. To solve this problem, we applied Grad-CAM to speaker recognition models trained by attaching a classifier after the pre-trained speaker verification models that extract speaker embeddings. The classification layer was trained to recognize 630 speakers from speaker embeddings, using TIMIT dataset [20]. 10 utterances for each speaker are divided in to test and training set by assigning 2 ‘SX’ utterances and remaining 8 utterances respectively [21, 22]. For (ii), as any part of the utterance belongs to one specific speaker, there is no point localizing the target map. Rather, it is necessary to visualize how the speaker verification model extracts speaker information from different frequency patterns of various phonemes at each time point. As the information regarding phonemes would be taken in earlier layer and the later layers would be most likely to contain only speaker-related information, we produced the speaker activation map (SAM) using gradients flowing into the first convolution layers. Therefore, we modified Grad-CAM to visualize SAM for text-independent speaker verification models as mentioned above.

4.2.1. Explanation on the behavior of DTDY-CNN’s static kernel and dynamic residual

To verify how DTDY-CNN-based models recognized speakers, SAM of DTDY-ResNet-34($\times 0.25$) was visualized using gradients of the first 6 DTDY-CNN layers for utterance SX429 by speaker FTAJ0 in Figure 2. It is observed that the whole adaptive kernel activated formant frequencies and harmonics for voiced sounds and high-frequency section for fricative sounds. Since the activation parts match the main

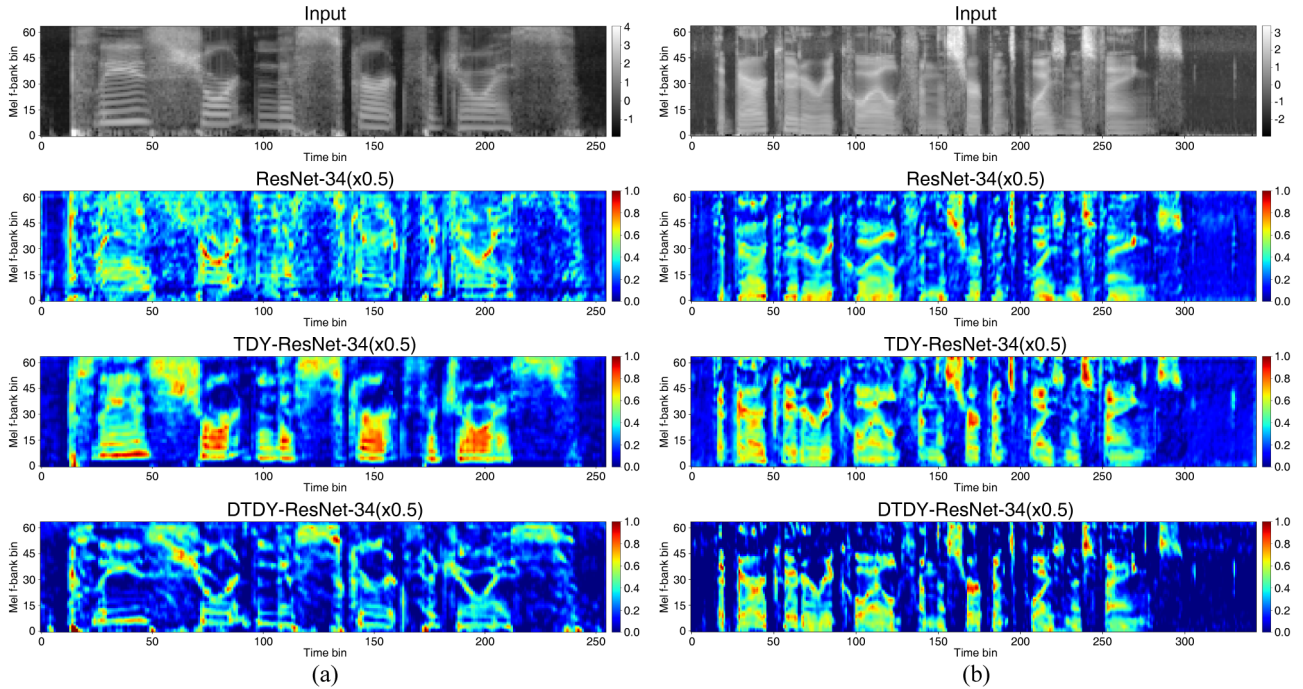

Figure 3: *Speaker activation maps of first 3 residual block in ResNet-34($\times 0.5$), TDY-ResNet-34($\times 0.5$), and DTDY-ResNet-34($\times 0.5$) for (a) SX384 by FLAG0 and (b) SX346 by MWGR0.*

acoustic characteristics of each phoneme, the adaptive kernel of DTDY-CNN extracts speaker information considering phonemes.

SAMs of static kernel and dynamic residual were also separately visualized to examine the role of each kernel. The sum of two maps is the same as the activation map of adaptive kernel. The static kernel mainly activates overall high-energy parts, including fundamental frequency and its harmonics. On the other hand, the dynamic residual activates detailed patterns of each phoneme, such as high-frequency formant frequencies and fricative sounds. Therefore, DTDY-CNN extracts speaker embeddings from utterances using the static kernel, which targets general features, and the dynamic residual, which targets detailed features of phonemes.

4.2.2. Comparisons of baseline model and temporal dynamic models for text-independent speaker verification

DTDY-CNN efficiently extracts speaker information by adaptive convolution kernels depending on phonemes using the dynamic residual of adaptive kernel. Moreover, to secure the validity of DTDY-CNN for text-independent speaker verification, it is necessary to objectively evaluate the ability of DTDY-CNN to activate key information of utterance. Thus, we compared SAMs of ResNet-34($\times 0.5$) using CNN, TDY-CNN, and DTDY-CNN for SX384 by FLAG0 and SX346 by MWGR0 as shown in Figure 3.

ResNet-34($\times 0.5$) activates wide frequency region of utterances and vague outline of each phoneme is shown. On the contrary, TDY-ResNet-34($\times 0.5$) and DTDY-ResNet-34($\times 0.5$) activate the low-frequency section for voiced sounds and the high-frequency section for fricative-like sounds. These models capture the acoustic characteristics of phonemes more clearly. Applying adaptive kernels on each time bin enabled appropriate decision of kernels to extract useful information depending on phonemes. However, there are differences

between two temporal dynamic models. TDY-ResNet-34($\times 0.5$) activates vague and flat frequency bands, whereas DTDY-ResNet-34($\times 0.5$) focus more on formant frequencies and harmonics of fundamental frequency. Considering that speaker is recognized by one’s voice tone that depends on the formant frequencies and harmonics, DTDY-CNN shows more speaker specific-characteristics to consider detailed features of phonemes than TDY-CNN does.

5. Conclusion

In this paper, we proposed decomposed temporal dynamic convolutional neural network (DTDY-CNN) to extract consistent speaker information from various phonemes by adapting kernels to each time bin for text-independent speaker verification. The adaptive kernel of DTDY-CNN is composed of static kernel and dynamic residual based on matrix decomposition for more efficient adaptive kernels. The models using DTDY-CNN showed better verification performance than the performance of static models. Compared to the models using TDY-CNN, the number of model parameters was reduced by 35% while maintaining the performance. Moreover, we analyzed the model using speaker activation map (SAM) modified from Grad-CAM to explain how DTDY-CNN extracts speaker information from utterances. The static kernel activated the overall pronunciation area, and the dynamic residual activated specific patterns of each phoneme. DTDY-CNN extracted more specific acoustic characteristics of phonemes including formants using these two kernels. While TDY-CNN also extracted features by adapting to phonemes, it activated vague frequency band regions that contains acoustic characteristics of the phonemes. Therefore, DTDY-CNN considers detailed features of phonemes maintaining speaker verification performance even with a small number of parameters. Both results and analysis with SAM indicate that DTDY-CNN effectively extract speaker information from various phonemes.

6. References

- [1] Eatock, J.P. and J.S. Mason. A quantitative assessment of the relative speaker discriminating properties of phonemes. in Proceedings of ICASSP'94. IEEE International Conference on Acoustics, Speech and Signal Processing. 1994. IEEE.
- [2] Jung, C.-S., M.Y. Kim, and H.-G. Kang, Selecting feature frames for automatic speaker recognition using mutual information. *IEEE Transactions on Audio, Speech, and Language Processing*, 2009. 18(6): p. 1332-1340.
- [3] Shon, S., H. Tang, and J. Glass. Frame-level speaker embeddings for text-independent speaker recognition and analysis of end-to-end model. in 2018 IEEE Spoken Language Technology Workshop (SLT). 2018. IEEE.
- [4] Kim, S.-H., H. Nam, and Y.-H. Park, Temporal Dynamic Convolutional Neural Network for Text-Independent Speaker Verification and Phonemetic Analysis. arXiv preprint arXiv:2110.03213, 2021.
- [5] Kim, S.-H. and Y.-H. Park, Adaptive Convolutional Neural Network for Text-Independent Speaker Recognition. *Proc. Interspeech 2021*, 2021: p. 66-70.
- [6] Gu, B., et al. An Adaptive X-vector Model for Text-independent Speaker Verification. in *Proc. Interspeech 2020*. 2020.
- [7] Gu, B. and W. Guo, Dynamic Convolution with Global-Local Information for Session-Invariant Speaker Representation Learning. *IEEE Signal Processing Letters*, 2021.
- [8] Chen, Y., et al. Dynamic convolution: Attention over convolution kernels. in Proceedings of the IEEE/CVF Conference on Computer Vision and Pattern Recognition. 2020.
- [9] Li, Y., et al., Revisiting dynamic convolution via matrix decomposition. arXiv preprint arXiv:2103.08756, 2021.
- [10] Arrieta, A.B., et al., Explainable Artificial Intelligence (XAI): Concepts, taxonomies, opportunities and challenges toward responsible AI. *Information fusion*, 2020. 58: p. 82-115.
- [11] Selvaraju, R.R., et al. Grad-cam: Visual explanations from deep networks via gradient-based localization. in Proceedings of the IEEE international conference on computer vision. 2017.
- [12] Hu, J., L. Shen, and G. Sun. Squeeze-and-excitation networks. in Proceedings of the IEEE conference on computer vision and pattern recognition. 2018.
- [13] He, K., et al. Deep residual learning for image recognition. in Proceedings of the IEEE conference on computer vision and pattern recognition. 2016.
- [14] Chung, J.S., et al., In defence of metric learning for speaker recognition. *Proc. Interspeech 2020*, 2020: p. 2977-2981.
- [15] Chung, J.S., A. Nagrani, and A. Zisserman. Voxceleb2: Deep speaker recognition. in *Proc. Interspeech 2018*. 2018.
- [16] Nagrani, A., J.S. Chung, and A. Zisserman. Voxceleb: a large-scale speaker identification dataset. in *Proc. Interspeech 2017*. 2017.
- [17] Nagrani, A., et al., Voxceleb: Large-scale speaker verification in the wild. *Computer Speech & Language*, 2020. 60: p. 101027.
- [18] Kwon, Y., et al. The ins and outs of speaker recognition: lessons from VoxSRC 2020. in ICASSP 2021-2021 IEEE International Conference on Acoustics, Speech and Signal Processing (ICASSP). 2021. IEEE.
- [19] Desplanques, B., J. Thienpondt, and K. Demuynck. ECAPA-TDNN: Emphasized Channel Attention, propagation and aggregation in TDNN based speaker verification. in *Proc. Interspeech 2020*. 2020.
- [20] Garofolo, J.S., et al., DARPA TIMIT acoustic-phonetic continuous speech corpus CD-ROM. NIST speech disc 1-1.1. NASA STI/Recon technical report n, 1993. 93: p. 27403.
- [21] Ward, N.C. and D.R. Dersch. Text-independent speaker identification and verification using the TIMIT database. in Fifth International Conference on Spoken Language Processing. 1998.
- [22] Gudnason, J. and M. Brookes. Voice source cepstrum coefficients for speaker identification. in 2008 IEEE International Conference on Acoustics, Speech and Signal Processing. 2008. IEEE.