

Shifted Chunk Encoder for Transformer Based Streaming End-to-End ASR

Fangyuan Wang¹, Bo Xu^{1,2,3}

¹ Institute of Automation, Chinese Academy of Science

² School of Future Technology, ³ School of Artificial Intelligence,
University of Chinese Academy of Sciences

{fangyuan.wang, xubo}@ia.ac.cn

Abstract

Currently, there are mainly three Transformer encoder based streaming End to End (E2E) Automatic Speech Recognition (ASR) approaches, namely time-restricted methods, chunk-wise methods, and memory based methods. However, all of them have some limitations in aspects of global context modeling, linear computational complexity, and model parallelism. In this work, we aim to build a single model to achieve the benefits of all the three aspects for streaming E2E ASR. Particularly, we propose to use a shifted chunk mechanism instead of the conventional chunk mechanism for streaming Transformer and Conformer. This shifted chunk mechanism can significantly enhance modeling power through allowing chunk self-attention to capture global context across local chunks, while keeping linear computational complexity and parallel trainable. We name the Shifted Chunk Transformer and Conformer as SChunk-Transformer and SChunk-Conformer, respectively. And we verify their performance on the widely used AISHELL-1 benchmark. Experiments show that the SChunk-Transformer and SChunk-Conformer achieve CER 6.43% and 5.77%, respectively. That surpasses the existing chunk-wise and memory based methods by a large margin, and is competitive even compared with the state-of-the-art time-restricted methods which have quadratic computational complexity¹.

Index Terms: streaming speech recognition, end-to-end speech recognition, shifted chunk, transformer, conformer

1. Introduction

In the past decades, great progress has been made to ASR with E2E models, which have become a popular alternative to conventional Hidden Markov Model (HMM)/Deep Neural Network (DNN) hybrid ASR models. Currently, there are mainly three E2E ASR systems, namely Connectionist Temporal Classification (CTC) [1][2], Recurrent Neural Network Transducer (RNN-T) [3][4][5], and Attention based Encoder-Decoder (AED) [6][7][8]. Also there are many efforts have been made to compare the performance of these models [9] and joint some of them into one hybrid model [10][11].

Recently, the Transformer [12] architecture has become a prevalent architecture, outperforming its counterpart RNN in E2E ASR [7][9]. Designed for sequence modeling tasks, the Transformer is notable for its use of attention to model global dependencies in the data and fast parallel training. In addition to replacing RNN in conventional AED systems, Transformer can also be used as an encoder with CTC [1] or Transducer [4] decoder. [8] has proposed a novel architecture called Conformer to combine convolution neural networks (CNN) and Transformers to model both local and global dependencies of an audio se-

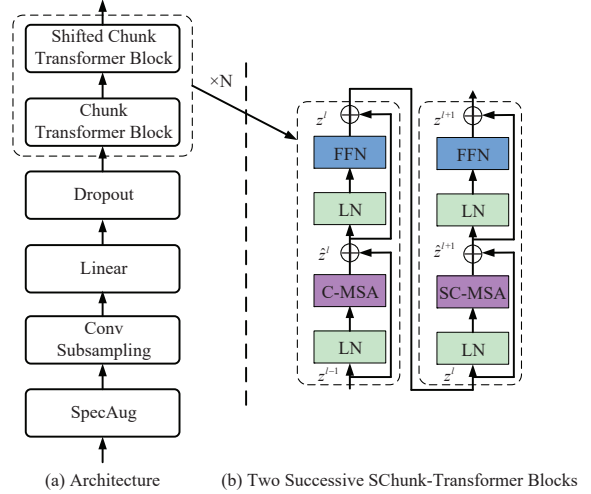

Figure 1: (a) The architecture of a SChunk-Transformer; (b) two successive SChunk-Transformer Blocks (notation presented with Eq. (3)). C-MSA and SC-MSA are multi-head self attention modules with regular and shifted chunk configurations, respectively.

quence in a parameter-efficient way. Espnet [13] and WeNet [14] have shown significant performance benefits obtained with the Conformer on a wide range of public available ASR corpora.

The tremendous success of Transformer and its variants encourage researchers to investigate its adaptation to online streaming scenario. Challenges in adapting Transformer from offline to online arise from differences between the two scenarios, such as limited future information and low latency requirement. However, two significant issues make transformer-based models impractical for online streaming scenario. First, it requires access to the entire sequence before it can start producing output; second, the computational cost and memory usage grow quadratically with respect to the input utterance length. Actually, several streaming Transformer based models have been proposed to partially address these issues. 1) Time-restricted methods [15][16][17][18][19][20] can be used in which the calculation of attention only uses the past input vectors and a limited length of future inputs. As the reception field grows linearly with the number of transformer layers, a large latency is introduced with the strategy. 2) Chunk-wise methods [4][21][22][31] which segment the input into small chunks and operate speech recognition on each chunk as the monotonic chunk-wise attention (MoChA) [23]. However, the accuracy often drops dramatically as the relationship between different chunks are ignored. 3) Memory based methods [24][26][25][27] employ a contextual

¹ We have submitted this paper to Interspeech 2022

vector to encode history information while reducing run time cost by combining with chunk-wise methods. However, memory based methods break the parallel nature of Transformer in training, typically requiring a longer training time.

In this paper, we seek to enhance the global context modeling ability for conventional chunk-wise methods without breaking the parallel nature of Transformer. This will lead a possibility to build a single model which can capture global history context (means a good accuracy performance), compute in linear complexity (means a low latency), and parallel trainable (means fast training) simultaneously. And fortunately, we find inspirations from the Swin Transformer[28] which is recently proposed in computer vision (CV) domain. What’s more, we find that the core idea of shifted window is very suitable for streaming ASR. First, the computation of self-attention of Swin Transformer is within local windows for efficient modeling, which has linear computational and memory complexity. And the idea of this window based attention is similar to chunk attention in speech domain. Second, except limiting calculation of self-attention within non-overlap local windows, Swin Transformer allows for cross-window connection using shifted windows to bridge the windows of the preceding layer, which can significantly enhance modeling power while maintaining the linear computational complexity. That is what the existing chunk-wise ASR methods lacks. We believe that by leveraging the idea of shifted window the modeling ability of chunk-wise method can also be significantly enhanced while keeping its original advantages.

To this regard, we propose a shifted chunk mechanism to replace conventional chunk-wise mechanism used in streaming Transformer and Conformer encoder. The shifted chunk mechanism extends chunk-wise attention to be calculated not only within local chunks but also between chunks, which significantly enhances the modeling power of global context capturing ability while keeping linear complexity and parallel trainable. We name the Shifted Chunk Transformer and Conformer as SChunk-Transofromer and SChunk-Conformer, respectively. To our knowledge, this is the first published work which builds a single transformer based streaming encoder to achieve the three benefits of global context modeling, linear computational complexity and parallel trainable simultaneously. Experiments show that the proposed SChunk-Transformer and SChunk-Conformer can achieve CER 6.43% and 5.77%, respectively. That surpasses the previous chunk-wise and memory based methods by a large margin, and is competitive even compared with the state-of-the-art time-restricted methods which have quadratic computational complexity.

2. Shifted Chunk Encoder

For convenience, we take SChunk-Transformer as an illustrative encoder to describe the mechanism of shifted chunk. The SChunk-Conformer can be built in a similar way.

2.1. Overall architecture

Our audio encoder first processes the input with a convolution subsampling layer and then with a number of chunk Transformer block and shifted chunk Transformer block, as illustrated in Figure 1(a). The distinctive feature of our model is the use of chunk Transformer block and shifted chunk Transformer block consecutively in the place of chunk Transformer blocks as in [4][21][22].



Figure 2: An illustration of the shifted chunk approach for computing self-attention. In layer l (top), a regular chunk partitioning scheme is adopted, and self-attention is computed within each chunk. In the next layer $l+1$ (bottom), the chunk partitioning is shifted, resulting in new chunks. The self-attention computation in the new chunks crosses the boundaries of the previous chunks in layer l , providing connections among them.

2.2. SChunk-Transformer block

SChunk-Transformer is built by replacing the standard multi-head self attention (MSA) module in a Transformer block by a module based on shifted chunk (described in Section 2.3), with other layers kept the same. As illustrated in Figure 1(b), a SChunk-Transformer block consists of a shifted chunk based MSA module, followed by a 2-layer Feed Forward Network (FFN) with GELU nonlinearity in between. A LayerNorm (LN) layer is applied before each MSA module and each FFN, and a residual connection is applied after each module.

2.3. Shifted Chunk based Self-Attention

The standard Transformer architecture[12] conducts global self-attention, where the relationships between a frame and all other frames are computed. The global computation leads to quadratic complexity with respect to the number of frames, making it unsuitable for streaming ASR requiring low latency.

Self-Attention in non-overlapped chunks. For efficient modeling, we compute self-attention within local chunks as in[4]. The chunks are arranged to evenly partition the audio in a non-overlapping manner. Supposing each chunk contains N frames, the computational complexity of a global MSA module and a chunk based one on an audio of L frames are²:

$$\Omega(MSA) = 4L \cdot C^2 + 2L^2 \cdot C \quad (1)$$

$$\Omega(SC-MSA) = 4L \cdot C^2 + 2N \cdot L \cdot C \quad (2)$$

where C is the feature embedding dimension of frames, and the former is quadratic to L , and the latter is linear when N is fixed (set to 16 by default). Global self-attention computation is generally unaffordable for a large L , which also explains why a large latency maybe caused for time-restricted systems.

Shifted chunk partitioning in successive blocks. The chunk based self-attention module lacks connections across chunks, which limits its modeling power. To introduce cross-chunk connections while maintaining the efficient computation of non-overlapping chunks, borrowing the idea of Swin Transformer[28], we propose a shifted chunk partitioning approach which alternates between two partitioning configurations in consecutive SChunk-Transformer blocks. As illustrated in Figure 2, the first module uses a regular chunk partitioning strategy which starts from the audio, and the feature sequence of 16 frames is evenly partitioned into 4 chunks of size 4 ($N=4$).

²We omit softmax computation in determining complexity

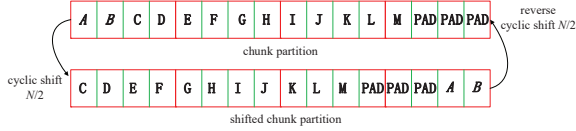

Figure 3: Illustration of an efficient batch computation approach for self-attention in shifted chunk partitioning.

Then, the next module adopts a chunking configuration that is shifted from that of the preceding layer, by displacing the chunks by $\lfloor N/2 \rfloor$ frames from the regularly partitioned chunks.

With the shifted chunk partitioning approach, consecutive SChunk-Transformer blocks are computed as:

$$\begin{aligned}
 \hat{z}^l &= C\text{-MSA}(LN(z^{l-1})) + z^{l-1}, \\
 z^l &= FFN(LN(\hat{z}^l)) + \hat{z}^l, \\
 \hat{z}^{l+1} &= SC\text{-MSA}(LN(z^l)) + z^l, \\
 z^{l+1} &= FFN(LN(\hat{z}^{l+1})) + \hat{z}^{l+1}
 \end{aligned} \tag{3}$$

where \hat{z}^l and z^l denote the output features of the (S)C-MSA module and the FFN module for block l , respectively; S-MSA and SC-MSA denote chunk based multi-head self attention using regular and shifted chunk partitioning configurations, respectively.

Efficient batch computation for shifted configuration.

An issue of shifted chunk partitioning for ASR batch computation is that different audio has different length. In order to be evenly partitioned into chunks, we pad audios in a batch to the same length which is a little longer than the longest audio in the batch and can be divided by the chunk size N . Another issue is that shifted chunks partitioning will result in more chunks, and some chunks will be smaller than N , as shown in Figure 2. Here, we use an efficient batch computation approach by cyclic-shifting the regular partitioned chunks from head to tail to get the shifted partitioned chunks, and reverse cyclic-shifting the shifted partitioned chunks from tail to head to re-get the regular partitioned chunks, as illustrated in Figure 3. With the cyclic-shift, the number of batched chunks remains the same as that of regular chunk partitioning, and thus is also efficient. By the way, this cyclic-shifting scheme can be easily implemented using the built-in Pytorch function `torch.roll()`.

Shifted chunk attention mask for streaming scenario.

As the other chunk-wise methods, chunk based self-attention can be calculated as shown in Figure 4(a), it can support streaming ASR with a low latency. However, for the shifted chunk situation, we need to mask out some areas as shown in Figure 4(b) to make sure frames can only attend to their preceding ones. For example, after shifting the first chunk in Figure 3 contains [C,D,E,F], where "C" and "D" can't attend to "E" and "F" as "E" and "F" are the future features before shifting, but "E" and "F" can attend to "C" and "D" as "C" and "D" belong to the past chunk originally.

2.4. SChunk-Conformer encoder

We can also use the chunk Transformer block and shifted chunk Transformer block consecutively in the place of chunk Transformer blocks in conventional chunk-wise streaming Conformer to get SChunk-Conformer. To make the CNN modules support streaming scenario, we follow the solution in [19] to use casual convolution instead.

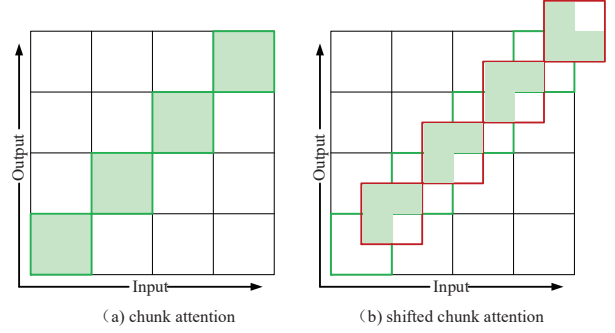

Figure 4: Illustration of chunk attention and shifted chunk attention.

3. Experiments

3.1. Data

We evaluate the proposed models on the open source Chinese Mandarin speech corpus AISHELL-1[29], which contains 150 hours training set, 10 hours dev set and 5 hours test set, the test set contain 7176 utterances in total. We use 80 dimensional log-mel filter bank (Fbank) splice 3 dimensional pitch computed on 25ms window with 10ms shift as feature. And we do speed perturb with 0.9, 1.0 and 1.1 on the whole data to generate 3-fold speed changes. Specaugment[30] is applied with 2 frequency masks with maximum frequency mask ($F = 50$), and 2 time masks with maximum time mask ($T = 50$).

3.2. Hybrid CTC/Attention streaming ASR

We implement all the proposed models based on the WeNet toolkit[14], which is a hybrid CTC/Attention Streaming ASR architecture also used in[19][20]. We identify two models, SChunk-Transformer and SChunk-Conformer as the shared encoder in hybrid CTC/Attention systems, respectively. For decoder aside, we follow the solution of [19], using a CTC decoder and a Attention decoder. The CTC decoder consists of a linear layer and a log softmax layer, The CTC loss function is applied over the softmax output in training. The Attention decoder consists of multiple Transformer decoder layers. The combined of CTC and AED can help model converge faster and have better performance as shown in[10]. The share encoder SChunk-Transformer or SChunk-Conformer consumes the audio feature chunk by chunk. The CTC decoder outputs first pass hypotheses in a streaming way. At the end of the input, the Attention decoder uses full context attention to get better results using rescoring mode decoding.

Two convolution sub-sampling layers with kernel size 3*3 and stride 2 is used in the front of the encoder, namely 4 times sub-sampling in total. For encoder, we use 12 SChunk-Transformer or SChunk-Conformer layers with 4 multi-head self attention. For the Attention Decoder, we use 6 transformer layers with 4 multihead attention. Both SChunk-Transformer and SChunk-Conformer use 256 attention dimension and 2048 feed forward dimension. Accumulating grad is also used to stabilize training, and we update parameters every four steps. Attention dropout, feed forward dropout and label smoothing regularization are applied in each encoder and decoder layer in order to prevent over-fitting. We use Adam optimizer and transformer learning rate schedule with 25000 warm-up steps to train these models for 80 epochs, and get our final model by averag-

ing the top 20 best models which have the lowest loss on the dev set at the training.

3.3. Baseline systems

We implement non-overlap conventional chunk-wise Transformer (Chunk-Transformer, C-T) and chunk-wise Conformer (Chunk-Conformer, C-C) using WeNet as the baseline systems. Since we use the same framework, the only difference between chunk based models and shifted chunk based ones is whether using the shifted chunk mechanism. As a ablation study, we can see whether the proposed solution can provide performance gains or not. We take U2[19] as another baseline system, and compare its accuracy and time cost with our models.

3.4. Ablation studies

We conduct ablations to get more understanding of the proposed SChunk-Transformer (SC-T) and SChunk-Conformer (SC-C).

The size of partition chunk. First, we explore how chunk size affects the model performance. As shown in Table 1, we can see the proposed models get better CER as the chunk size gets larger. In order to be comparable with other solutions, we set chunk size to 16 by default in the other experiments.

Table 1: Comparison with different chunk size (CER%)

Model Architecture	Chunk Size			
	4	8	16	32
SC-T	7.76	6.68	6.43	5.92
SC-C	7.38	6.21	5.77	5.64

The number of encoder layer. We also investigate to use more encoder layer to allow more sufficient global context capturing. The results are shown in Table 2, the SC-T achieves the best CER with 16 layers, while SC-C achieves the best CER using 12 layers. We conjecture this is because complicate encoder is more easier to be overfitting. For the following experiments, we set encoder layer to 12 by default.

Table 2: Comparison with different layer number (CER%)

Model Architecture	Layer Number			
	12	14	16	18
SC-T	6.43	6.25	6.02	6.12
SC-C	5.77	5.81	5.98	6.72

3.5. Comparison with baseline systems

As shown in Table 3, both SC-T and SC-C can significantly surpass their counterpart C-T and C-C, respectively. Even compared with the state-of-the-art time restricted models U2-Transformer (U2-T) and U2-Conformer (U2-C), the CERs of proposed models are still competitive while a low latency can be guaranteed in theory.

Table 3: The results of comparison with baseline systems

Model	C-T	C-C	U2-T	U2-C	SC-T	SC-C
CER	11.80,	6.69	6.05,	5.42	6.43	5.77

The time cost differences of SC-T and SC-C encoders with their counterpart in U2 are limited in our experiments. The total time cost of a *matmul* for shifted chunk attention operations in prediction stage is 12.39 seconds while 13.63 seconds for conventional one. However, this is reasonable as the audio frames L in AISHELL-1 is typically smaller the embedding dimension C , which makes C become the main factor affecting time-consuming. We will conduct more evaluation for our models on corpora of longer utterances in the future.

3.6. Comparison with other streaming solutions

Table 4 lists several recently published Transformer encoder based streaming solutions on AISHELL-1 test set. We can see the SChunk-Transformer can surpass all the other chunk-wise Transformer models [21][31], and memory based Transformer models[25][26] by a large margin. Even compared with the time-restricted models U2 and U2++ which have quadratic computational complexity, the SChunk-Conformer can still achieve competitive CER while keeping linear complexity.

Table 4: Comparison with other streaming solutions (CER%), \ddagger , \dagger , and \ddagger indicate the solution is a time-restricted method, a chunk-wise method and a memory based method, respectively. Δ is the additional latency introduced by attention rescoring.

Model	Type	Latency(ms)	CER
Sync-Transformer[21]	\dagger	400	8.91
SCAMA[25]	\ddagger	600	7.39
MMA[26]	\ddagger	400	6.60
HS-DACS [31]	\dagger	400	6.80
U2 (Conformer)[19]	\ddagger	400+ Δ	5.42
U2++ (U2+BiDec)[20]	\ddagger	400+ Δ	5.05
SC-T(ours)	\dagger	400+ Δ	6.43
SC-C(ours)	\dagger	400+ Δ	5.77

4. Discussion

Our work shows a way to build a single streaming E2E ASR model to achieve the benefits of global context modeling, linear complexity and parallel trainable simultaneously. Although the time-restrict models can achieve a little bit better CERs, they can't ensure a low latency in theory makes them impractical for scenarios with long audios. As the shifted chunk based models can achieve competitive CERs while be insensitive to audio length, they may have a great potential in commercial systems.

5. Conclusions

We introduce a shifted chunk mechanism for streaming Transformer and Conformer models. This mechanism can significantly enhance the modeling power through allowing local self-attention to capture global context across chunks, while keeping linear complexity and parallel trainable. Experimental results on AISHELL-1 show that our models can surpass the previous chunk-wise and memory based methods by a large margin, and be competitive even with the state-of-the-art time-restricted methods while keeping linear complexity.

6. Acknowledgements

This work is supported by the National Innovation 2030 Major S&T Project of China under Grant 2020AAA0104202.

7. References

- [1] J. Li, G. Ye, A. Das, R. Zhao, and Y. Gong, "Advancing acoustic-to-word CTC model," in *ICASSP 2018 – 43rd IEEE International Conference on Acoustics, Speech and Signal Processing, April 22-27, Seoul, South Korea*, 2018, pp. 5794–5798.
- [2] A. Graves, S. Fernandez, F. Gomez, and J. Schmidhuber, "Connectionist temporal classification: labelling unsegmented sequence data with recurrent neural networks," in *ICML 2006 – 23rd International Conference on Machine Learning, June 25-29, Pittsburgh, Pennsylvania*, 2006, pp. 369–376.
- [3] E. Battenberg, J. T. Chen et al. "Exploring neural transducers for end-to-end speech recognition," in *ASRU 2017 – 2017 IEEE Automatic Speech Recognition and Understanding Workshop, December 16-20, Okinawa, Japan*, 2017, pp. 206–213.
- [4] X. Chen, Y. Wu, Z. Wang, et al., "Developing real-time streaming transformer transducer for speech recognition on large-scale dataset," in *ICASSP 2021 – 46th IEEE International Conference on Acoustics, Speech and Signal Processing, June 6-11, Toronto, Ontario, Canada*, 2021, pp. 5904–5908.
- [5] A. Graves, A. R. Mohamed, and G. Hinton, "Speech recognition with deep recurrent neural networks," in *ICASSP 2013 – 38th IEEE International Conference on Acoustics, Speech and Signal Processing, May 26-30, Vancouver, Canada*, 2013, pp. 6645–6645.
- [6] W. Chan, N. Jaitly, Q. Le, and O. Vinyals. "Listen, attend and spell: A neural network for large vocabulary conversational speech recognition," in *ICASSP 2016 – 41st IEEE International Conference on Acoustics, Speech and Signal Processing, March 20-25, Shanghai, China*, 2016, pp. 4960–4964.
- [7] L. H. Dong, B. Xu, "CIF: Continuous Integrate-And-Fire for End-To-End Speech Recognition," in *ICASSP 2020 – 45th IEEE International Conference on Acoustics, Speech and Signal Processing, May 4-8, Barcelona, Spain*, 2020, pp. 6079–6083.
- [8] A. Gulati, J. Qin, C. C. Chiu, et al., "Conformer: convolution-augmented transformer for speech recognition," in *Interspeech 2020 – 21st Annual Conference of the International Speech Communication Association, October 25-30, Shanghai, China*, 2020, pp. 5036–5040.
- [9] R. Prabhavalkar, K. Rao, T. N. Sainath, B. Li, L. Johnson, and N. Jaitly, "A comparison of sequence-to-sequence models for speech recognition," in *Interspeech 2017 – 18th Annual Conference of the International Speech Communication Association, August 20-24, Stockholm, Stockholm County, Sweden*, 2017, pp. 939–939.
- [10] S. Watanabe, T. Hori, S. Kim, J. R. Hershey, T. Hayashi, "Hybrid CTC/Attention Architecture for End-to-End Speech Recognition," *IEEE Journal of Selected Topics in Signal Processing*, vol. 11, no. 8, pp. 1240–1253, 2017.
- [11] H. R. Miao, G. F. Cheng, P. Y. Zhang, Y. H. Yan, "Online Hybrid CTC/Attention End-to-End Automatic Speech Recognition Architecture," *IEEE/ACM Transactions on Audio, Speech, and Language Processing*, vol. 28, pp. 1452–1465, 2020.
- [12] A. Vaswani, N. Shazeer, N. Parmar et al., "Attention is all you need," in *NIPS 2017 – 31st Conference on Neural Information Processing Systems, December 4-9, Long Beach, California, U.S.A.*, 2017, pp. 5998–6008.
- [13] P. C. Guo, F. Boyer, X. K. Chang et al., "Recent Developments on Espnet Toolkit Boosted By Conformer," in *ICASSP 2021 – 46th IEEE International Conference on Acoustics, Speech and Signal Processing, June 6-11, Toronto, Ontario, Canada*, 2021, pp. 5874–5878.
- [14] Z. Yao, D. Wu, X. Wang et al., "WeNet: Production oriented streaming and non-streaming end-to-end speech recognition toolkit," in *Interspeech 2021 – 22nd Annual Conference of the International Speech Communication Association, August 30-September 3, Brno, Czech Republic*, 2021.
- [15] Q. Zhang, H. Lu, et al., "Transformer transducer: A streamable speech recognition model with transformer encoders and rnn-t loss," in *ICASSP 2020 – 45th IEEE International Conference on Acoustics, Speech and Signal Processing, May 4-8, Barcelona, Spain*, 2020, pp. 7829–7833.
- [16] N. Moritz, T. Hori, and J. L. Roux, "Streaming automatic speech recognition with the transformer model," in *ICASSP 2020 – 45th IEEE International Conference on Acoustics, Speech and Signal Processing, May 4-8, Barcelona, Spain*, 2020, pp. 6074–6078.
- [17] J. H. Yu, W. Han, et al., "Universal ASR: Unify and improve streaming ASR with full-context modeling," arXiv preprint arXiv:2010.06030, 2020.
- [18] A. Tripathi, J. Kim, Q. Zhang, et al., "Transformer transducer: One model unifying streaming and non-streaming speech recognition," arXiv preprint arXiv:2010.03192, 2020.
- [19] B. B. Zhang, D. Wu, Z. Y. Yao, et al., "Unified Streaming and Non-streaming Two-pass End-to-end Model for Speech Recognition," arXiv preprint arXiv:2012.05481, 2020.
- [20] D. Wu, B. B. Zhang, C. Yang, et al., "U2++: Unified Two-pass Bidirectional End-to-end Model for Speech Recognition," arXiv preprint arXiv:2106.05642, 2021.
- [21] Z. K. Tian, J. Y. Yi, Y. Bai, et al., "Synchronous transformers for end-to-end speech recognition," in *ICASSP 2020 – 45th IEEE International Conference on Acoustics, Speech and Signal Processing, May 4-8, Barcelona, Spain*, 2020, pp. 7884–7888.
- [22] C. Y. Wang, Y. Wu, S. J. Liu, et al., "Reducing the latency of end-to-end streaming speech recognition models with a scout network," in *Interspeech 2020 – 21st Annual Conference of the International Speech Communication Association, October 25-30, Shanghai, China*, 2020.
- [23] C. -C. Chiu, C. Raffel, "Monotonic chunkwise attention," in *ICLR 2018 – 6th International Conference on Learning Representations, April 30-May 3, Vancouver Canada*, 2018.
- [24] C. Y. Wu, Y. Q. Wang, Y. Y. Shi, et al. "Streaming transformer-based acoustic models using self-attention with augmented memory," in *Interspeech 2020 – 21st Annual Conference of the International Speech Communication Association, October 25-30, Shanghai, China*, 2020, pp. 2132–2136.
- [25] S. L. Zhang, Z. F. Gao, H. N. Luo, et al. "Streaming Chunk-Aware Multihead Attention for Online End-to-End Speech Recognition," in *Interspeech 2020 – 21st Annual Conference of the International Speech Communication Association, October 25-30, Shanghai, China*, 2020, pp. 2142–2146.
- [26] H. Inaguma, M. Mimura, T. Kawahara, "Enhancing Monotonic Multihead Attention for Streaming ASR," in *Interspeech 2020 – 21st Annual Conference of the International Speech Communication Association, October 25-30, Shanghai, China*, 2020, pp. 2137–2141.
- [27] Y. Y. Shi, Y. Q. Wang, C. Y. Wu, et al. "Emformer: Efficient Memory Transformer Based Acoustic Model for Low Latency Streaming Speech Recognition," in *ICASSP 2021 – 46th IEEE International Conference on Acoustics, Speech and Signal Processing, June 6-11, Toronto, Ontario, Canada*, 2021, pp. 6783–6787.
- [28] Z. Liu, Y. T. Cao, et al. "Swin Transformer: Hierarchical Vision Transformer using Shifted Windows," in *ICCV 2021 – 46th International Conference on Computer Vision, October 11-17, Virtual*, 2021, pp. 10012–10022.
- [29] H. Bu, J. Du, X. Na, B. Wu, and H. Zheng, "Aishell-1: An open-source mandarin speech corpus and a speech recognition baseline," in *O-COCOSDA 2017 – 20th Conference of the Oriental Chapter of the International Coordinating Committee on Speech Databases and Speech I/O Systems and Assessment, November 1-3, Seoul, South Korea*, 2015, pp. 1–5.
- [30] D. S. Park, W. Chan, Y. Zhang, C.C. Chiu, et al. "SpecAugment: A simple data augmentation method for automatic speech recognition," in *Interspeech 2019 – 20th Annual Conference of the International Speech Communication Association, September 15-19, Graz, Austria*, 2019, pp. 2613–2617.
- [31] M. Li, C. Zorilă, R. Doddipatla, "Head-Synchronous Decoding for Transformer-Based Streaming ASR," in *ICASSP 2021 – 46th IEEE International Conference on Acoustics, Speech and Signal Processing, June 6-11, Toronto, Ontario, Canada*, 2021, pp. 5909–5913.