

Generalised entropy accumulation

Tony Metger^{*1}, Omar Fawzi², David Sutter³, and Renato Renner¹

¹Institute for Theoretical Physics, ETH Zurich, 8093 Zürich, Switzerland

²Univ Lyon, ENS Lyon, UCBL, CNRS, Inria, LIP, F-69342, Lyon Cedex 07, France

³IBM Quantum, IBM Research Europe – Zurich, Switzerland

Abstract

Consider a sequential process in which each step outputs a system A_i and updates a side information register E . We prove that if this process satisfies a natural “non-signalling” condition between past outputs and future side information, the min-entropy of the outputs A_1, \dots, A_n conditioned on the side information E at the end of the process can be bounded from below by a sum of von Neumann entropies associated with the individual steps. This is a generalisation of the entropy accumulation theorem (EAT) [DFR20], which deals with a more restrictive model of side information: there, past side information cannot be updated in subsequent rounds, and newly generated side information has to satisfy a Markov condition. Due to its more general model of side-information, our generalised EAT can be applied more easily and to a broader range of cryptographic protocols. As examples, we give the first multi-round security proof for blind randomness expansion and a simplified analysis of the E91 QKD protocol. The proof of our generalised EAT relies on a new variant of Uhlmann’s theorem and new chain rules for the Rényi divergence and entropy, which might be of independent interest.

1 Introduction

Suppose that Alice and Eve share a quantum state $\rho_{A^n E}$. From her systems $A^n := A_1 \dots A_n$, Alice would like to extract bits that look uniformly random to Eve, except with some small failure probability ε . The number of such random bits that Alice can extract is given by the smooth min-entropy $H_{\min}^\varepsilon(A^n|E)_\rho$ [Ren08]. This quantity plays a central role in quantum cryptography: for example, the main task in security proofs of quantum key distribution (QKD) protocols is usually finding a lower bound for the smooth min-entropy.

Unfortunately, for many cryptographic protocols deriving such a bound is challenging. Intuitively, the reason is the following: the state $\rho_{A^n E}$ is usually created as the output of a multi-round protocol, where each round produces one of Alice’s systems A_i and allows Eve to execute some attack to gain information about A_1, \dots, A_i . These attacks can depend on each other, i.e., Eve may use what she learnt in round $i - 1$ to plan her attack in round i . This non-i.i.d. nature of the attacks makes it hard to find a lower bound on $H_{\min}^\varepsilon(A^n|E)_\rho$ that holds for any possible attack that Eve can execute. In contrast, it is typically much easier to compute a conditional von Neumann entropy associated with a single-round of the protocol, where the non-i.i.d. nature of Eve’s attack plays no role. Therefore, it is desirable to relate the smooth min-entropy of the output of the multi-round protocol to the von Neumann entropies associated with the individual rounds.

From an information-theoretic point of view, this question can be phrased as follows: can the smooth min-entropy $H_{\min}^\varepsilon(A^n|E)_\rho$ be bounded from below in terms of von Neumann entropies $H(A_i|E_i)_{\rho_{A_i E_i}^i}$ for

*Email: tmetger@ethz.ch

some (yet to be determined) systems E_i and states $\rho_{A_i E_i}^i$ related to ρ ? While for general states $\rho_{A^n E}$ no useful lower bound can be found, previous works have established such bounds under additional assumptions on the state $\rho_{A^n E}$.

The first bound of this form was proven via the *asymptotic equipartition property* (AEP) [TCR09]. It assumes that the system E is n -partite (i.e., we replace E by $E^n = E_1 \dots E_n$) and that the state $\rho_{A^n E^n} = \rho_{A_1 E_1} \otimes \dots \otimes \rho_{A_n E_n}$ is a product of identical states. Then, the AEP shows that¹

$$H_{\min}^{\epsilon}(A^n | E^n)_{\rho} \geq \sum_{i=1}^n H(A_i | E_i)_{\rho} - O(\sqrt{n}).$$

For applications in cryptography, the assumption that ρ is an i.i.d. product state is usually too strong: it corresponds to the (unrealistic) assumption that Eve executes the same independent attack in each round, a so-called *collective attack*.

The *entropy accumulation theorem* (EAT) [DFR20] is a generalisation of the AEP which requires far weaker assumptions on the state $\rho_{A^n E}$. Specifically, the EAT considers states that result from a sequential process that starts with a state $\rho_{R_0 E'}^0$ and in every step outputs a system A_i and a piece of side information I_i . The system E' is not acted upon during the process. The full side information at the end of this process is $E = I_1 \dots I_n E'$. We can represent such a process by the following diagram, where \mathcal{M}_i are quantum channels.

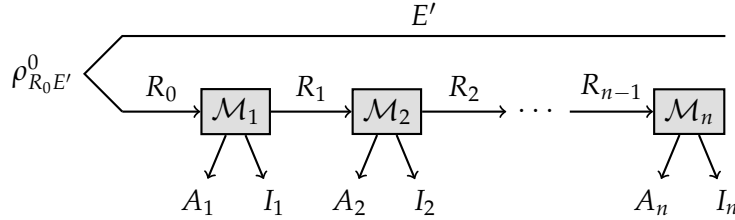

The EAT requires an additional condition on the side information: the new side information I_i generated in round i must be independent from the past outputs A^{i-1} conditioned on the existing side information $I^{i-1} E'$. Mathematically, this is captured by the condition that the systems $A^{i-1} \leftrightarrow I^{i-1} E' \leftrightarrow I_i$ form a Markov chain for any initial state $\rho_{R_0 E'}^0$. With this Markov condition, the EAT states that²

$$H_{\min}^{\epsilon}(A^n | I^n E')_{\mathcal{M}_n \circ \dots \circ \mathcal{M}_1(\rho_{R_0 E'}^0)} \geq \sum_{i=1}^n \inf_{\omega} H(A_i | I_i \tilde{E})_{\mathcal{M}_i(\omega)} - O(\sqrt{n}), \quad (1.1)$$

where \tilde{E} is a purifying system isomorphic to R_{i-1} and the infimum is taken over all states ω on systems $R_{i-1} \tilde{E}$.³

Let us discuss the model of side information used by the EAT in more detail. The EAT considers side information consisting of two parts: the initial side information E' (which is not acted upon during the process) and the outputs $I^n = I_1 \dots I_n$. This splitting of side information into a “static” part E' and a part

¹Since ρ is a product of identical states, all of the terms $H(A_i | E_i)_{\rho}$ are equal, i.e., $\sum_{i=1}^n H(A_i | E_i)_{\rho} = nH(A_i | E_i)_{\rho}$ for any i . We write the sum here explicitly to highlight the analogy with the EAT presented below.

²The EAT from [DFR20] also makes an analogous statement about an upper bound on the max-entropy H_{\max} . We derive a generalisation of that statement in Appendix A but only focus on H_{\min} in the introduction and main text since that is the case that is typically relevant for applications.

³In fact, the EAT is more general in that it allows taking into account observed statistics to restrict the minimization over $\omega_{A_i B_i E}$, but we restrict ourselves to the simpler case without statistics in this introduction.

I^n which is generated in each step of the process is particularly suited to device-independent cryptography: there, Eve prepares a device in an initial state $\rho_{R_0 E'}^0$, where R_0 is the device’s internal memory and E' is Eve’s initial side information from preparing the device. Then, Alice (and Bob, though we only consider Alice’s system here) executes a multi-round protocol with this device, where each round leaks some additional piece of information I_i to Eve, so that Eve’s side information at the end of the protocol is $I^n E'$. Indeed, the EAT has been used to establish tight security proofs in the device-independent setting, see e.g., [AFDF⁺18, BMP18].

The Markov condition in the EAT captures the following intuition: if we want to find a bound on $H_{\min}^\varepsilon(A^n | I^n E')$ in terms of single-round quantities, it is required that side information about A_i is itself output in step i , as otherwise we cannot hope to estimate the contribution to the total entropy from step i . To illustrate what could happen without such a condition, consider a case where A_i is classical and no side information is output in the first $n - 1$ rounds, but the side information I_n in the last round contains a copy of the systems A^n (which can be passed along during the process in the systems R_i). Then, clearly $H_{\min}^\varepsilon(A^n | I^n E') = 0$, but for the first $n - 1$ rounds, each single-round entropy bound that only considers the systems A_i and I_i can be positive.

In this work, we further relax the assumptions on how the final state $\rho_{A^n E}$ is generated. Specifically, we consider sequential processes as in the EAT, but with a fully general model of side information, i.e., the side information can be updated in each step in the process. Diagrammatically, such a process can be represented as follows:

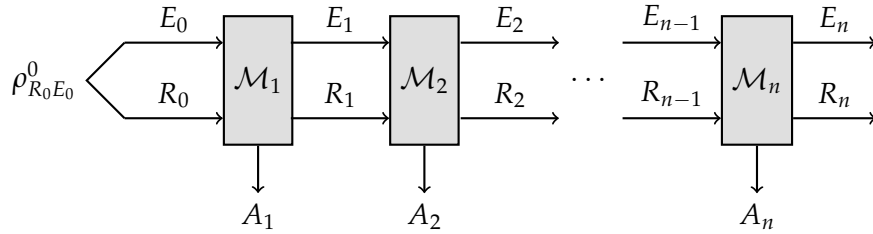

For our generalised EAT, we further require that the quantum channels \mathcal{M}_i satisfy the following “non-signalling” condition (discussed in detail below): for each $\mathcal{M}_i : R_{i-1} E_{i-1} \rightarrow A_i R_i E_i$, there must exist a quantum channel $\mathcal{R}_i : E_{i-1} \rightarrow E_i$ such that

$$\text{Tr}_{A_i R_i} \circ \mathcal{M}_i = \mathcal{R}_i \circ \text{Tr}_{R_{i-1}}. \quad (1.2)$$

Our main result, a generalised EAT, states that under this assumption,

$$H_{\min}^\varepsilon(A^n | E_n)_{\mathcal{M}_n \circ \dots \circ \mathcal{M}_1(\rho_{R_0 E_0}^0)} \geq \sum_{i=1}^n \inf_{\omega} H(A_i | E_i \tilde{E}_{i-1})_{\mathcal{M}_i(\omega)} - O(\sqrt{n}), \quad (1.3)$$

where $\tilde{E}_{i-1} \equiv R_{i-1} E_{i-1}$ is a purifying system and the infimum is taken over all states ω on systems $R_{i-1} E_{i-1} \tilde{E}_{i-1}$. We give a formal statement in [Theorem 4.1](#) and also show that, similarly to the EAT, statistics collected during the process can be used to restrict the minimization over ω (see [Theorem 4.3](#) for the formal statement). By a simple duality argument, [Equation \(1.3\)](#) also implies an upper bound on the smooth max-entropy H_{\max} , which we explain in [Appendix A](#). This generalises a similar result from [DFR20], although in [DFR20] one could not make use of duality due to the Markov condition and instead had to prove the statement about H_{\max} separately, again highlighting that our generalised EAT is easier to work with.

The intuition behind the non-signalling condition in our generalised EAT is similar to the Markov condition in the original EAT: by the same reasoning as for the Markov condition, since the lower bound is made

up of terms of the form $H(A_i|E_i\tilde{E}_{i-1})_{\mathcal{M}_i(\omega)}$, it is required that side information about A_i that is present in the final system E_n is already present in E_i . This means that side information about A_i should not be passed on via the R -systems and later be included in the E -systems. The non-signalling condition captures this requirement: it demands that if one only considers the marginal of the new side information E_i (without the new output A_i), it must be possible to generate this state from the past side information E_{i-1} alone, without access to the system R_{i-1} . This means that any side information that E_i contains about the past outputs $A_1 \dots A_{i-1}$ must have essentially already been present in E_{i-1} and could not have been stored in R_{i-1} .

The name “non-signalling condition” is due to the fact that Equation (1.2) is a natural generalisation of the standard non-signalling conditions in non-local games: if we view the systems R_{i-1} and $R_i A_i$ as the inputs and outputs on “Alice’s side” of \mathcal{M}_i , and E_{i-1} and E_i as the inputs and outputs on “Eve’s side”, then Equation (1.2) states that the marginal of the output on Eve’s side cannot depend on the input on Alice’s side. This is exactly the non-signalling condition in non-local games, except that here the inputs and outputs are allowed to be fully quantum.

To understand the relation between the Markov and non-signalling conditions, it is instructive to consider the setting of the original EAT as a special case of our generalised EAT. In the original EAT, the full side information available after step i is $E^i I^i$, and past side information is not updated during the process. For our generalised EAT, we therefore set $E_i = E^i I^i$ and consider maps $\mathcal{M}_i = \mathcal{M}'_i \otimes \text{id}_{E_{i-1}}$, where $\mathcal{M}'_i : R_{i-1} \rightarrow A_i I_i R_i$ is the map used in the original EAT. We need to check that with this choice of systems and maps, the Markov condition of the original EAT implies the non-signalling condition of our generalised EAT. The Markov condition requires that for any state input $\omega_{A^{i-1} I^{i-1} R_{i-1} E'}$, the output state $\omega_{A^i I^i R_i E'} = \mathcal{M}_i(\omega^{i-1})$ satisfies $A^{i-1} \leftrightarrow I^{i-1} E' \leftrightarrow I_i$.⁴ It is then a standard result on quantum Markov chains [Pet86] that there must exist a quantum channel $\mathcal{R}_i : I^{i-1} E' \rightarrow I^i E'$ such that $\omega_{I^i E'}^i = \mathcal{R}_i(\omega_{I^{i-1} E'}^{i-1})$. Remembering that we defined $E_i = E^i I^i$ (so that $\mathcal{R}_i : E_{i-1} \rightarrow E_i$) and adding the systems A^{i-1} (on which both \mathcal{M}_i and \mathcal{R}_i act as identity), we find that \mathcal{M}_i satisfies the non-signalling condition:

$$\text{Tr}_{A_i R_i} \circ \mathcal{M}_i(\omega_{A^{i-1} R_{i-1} E_{i-1}}^{i-1}) = \omega_{A^{i-1} E_i}^i = \mathcal{R}_i(\omega_{A^{i-1} E_{i-1}}^{i-1}) = \mathcal{R}_i \circ \text{Tr}_{R_{i-1}}(\omega_{A^{i-1} R_{i-1} E_{i-1}}^{i-1}).$$

Then, noting that all conditioning systems on which \mathcal{M}_i acts as the identity map can collectively be replaced by a single purifying system isomorphic to the input, we see that we recover the original EAT (Equation (1.1)) from our generalised EAT (Equation (1.3)).

We emphasise that while the original EAT with the Markov condition can be recovered as a special case, our model of side information and the non-signalling condition are much more general than the original EAT; arguably, for a sequential process they are the most natural and general way of expressing the notion that future side information should not contain new information about past outputs, which appears to be necessary for an EAT-like result. To demonstrate the greater generality of our result, in Section 5 we use it to give the first multi-round proof for blind randomness expansion, a task to which the original EAT could not be applied, and a more direct proof of the E91 QKD protocol than was possible with the original EAT. Our generalised EAT can also be used to prove security of a much larger class of QKD protocols than the original EAT. Interestingly, for (device-dependent) QKD protocols, no “hidden system” R is needed and therefore the non-signalling condition is trivially satisfied, i.e., the advantage of our generalised EAT for QKD security proofs stems entirely from the more general model of side information, not from replacing the Markov condition by the non-signalling condition; see Section 5.2 for an informal comparison of how the

⁴Strictly speaking, the EAT as stated in [DFR20] only requires that this Markov property holds for any input state ω^{i-1} in the image of the previous maps $\mathcal{M}_{i-1} \circ \dots \circ \mathcal{M}_1$. The same is true for the non-signalling condition, i.e., one can check that our proof of the generalised EAT still works if the map \mathcal{R}_i only satisfies Equation (1.2) on states in the image of $\mathcal{M}_{i-1} \circ \dots \circ \mathcal{M}_1$. To simplify the presentation, we use the stronger condition Equation (1.2) throughout this paper.

original and generalised EAT can be applied to QKD, and [MR22] for a detailed treatment of the application of our generalised EAT to QKD, including protocols to which the original EAT could not be applied.

Future work. Compared to the original EAT [DFR20], our generalised EAT features a more general model of side information and a weaker condition on the relation between different rounds, replacing the Markov condition of [DFR20] with our weaker non-signalling condition in Equation (1.2). It is natural to ask whether a further step in this direction is possible: while the model of side information we consider is fully general, it may be possible to replace the non-signalling condition with a weaker requirement. We have argued above that our non-signalling condition appears to be the most general way of stating the requirement that future side information does not reveal information about past outputs, which seems necessary for an EAT-like theorem. It would be interesting to formalise this intuition and see whether our theorem is provably “tight” in terms of the conditions placed on the sequential process.

Furthermore, it might be possible to improve the way the statistical condition in Theorem 4.3 is dealt with in the proof. We deal with this very similarly to [DFR20, DF19], but that proof technique is not particularly direct. A more natural way of incorporating the statistical condition may also allow a weakening of the condition in Equation (4.1), which might further simplify the application of our generalised EAT to QKD [MR22]. An alternative to the EAT, called *quantum probability estimation* (QPE) [ZFK20, KZB20], features an arguably more elegant way of dealing with classical statistics, but is less general in other respects. It might be interesting to see whether ideas from QPE can be incorporated into our proof of the generalised EAT.

Finally, a more ambitious goal would be to extend entropy accumulation from conditional entropies to relative entropies. Such a *relative entropy accumulation theorem* (REAT) would be the following statement: for two sequences of channels $\{\mathcal{E}_1, \dots, \mathcal{E}_n\}$ and $\{\mathcal{F}_1, \dots, \mathcal{F}_n\}$ (where \mathcal{F}_i need not necessarily be trace-preserving), and $\varepsilon > 0$,

$$D_{\max}^{\varepsilon}(\mathcal{E}_n \circ \dots \circ \mathcal{E}_1 \parallel \mathcal{F}_n \circ \dots \circ \mathcal{F}_1) \stackrel{?}{\leq} \sum_{i=1}^n D^{\text{reg}}(\mathcal{E}_i \parallel \mathcal{F}_i) + O(\sqrt{n}).$$

Here, D_{\max}^{ε} is the ε -smooth max-relative entropy [Tom15] and we used the (regularised) channel divergences defined in Definition 2.5. The key technical challenge in proving this result is to show that the regularised channel divergence $D_{\alpha}^{\text{reg}}(\mathcal{E}_i \parallel \mathcal{F}_i)$ is continuous in α at $\alpha = 1$, which is an important technical open question. If one had such a continuity statement and the maps \mathcal{F}_i additionally satisfied a non-signalling condition (which is not required for the statement above), one could also use our Theorem 3.1 to derive a more general REAT, which would imply our generalised EAT.

Structure of the proof. Like the original EAT, our generalised EAT is based on a chain rule for Rényi entropies (Lemma 3.6). The first step in its proof is a new variant of Uhlmann’s theorem [Uhl76] for Rényi divergences of any order $\alpha > 1$ (Lemma 3.3), whereas Uhlmann’s theorem deals with the case $\alpha = 1/2$. Then, we combine Lemma 3.3 with a result from [FF21] to obtain a new chain rule for the Rényi channel divergence (Theorem 3.1). This chain rule involves a regularised channel divergence. In Section 3.2, we show that in the special case relevant for entropy accumulation, the regularisation disappears. The result, Lemma 3.6, is a chain rule for Rényi entropies like the one in [DFR20], but more adapted to the task of entropy accumulation. Using this chain rule, we proceed similarly to [DFR20] to prove our generalised EAT (Theorem 4.1). We also provide a version that allows for “testing” (Section 4.2) and features explicit second-order terms similar to those in [DF19].

2 Preliminaries

2.1 Notation

The set of positive semidefinite operators on a quantum system A (with associated Hilbert space \mathcal{H}_A) is denoted by $\text{Pos}(A)$. The set of quantum states is given by $\mathcal{S}(A) = \{\rho \in \text{Pos}(A) \mid \text{Tr}[\rho] = 1\}$. The set of completely positive maps from linear operators on A to linear operators on A' is denoted by $\text{CP}(A, A')$. If such a map is additionally trace preserving, we call it a quantum channel and denote the set of such maps by $\text{CPTP}(A, A')$. The identity channel on system A is denoted as id_A . The spectral norm is denoted by $\|\cdot\|_\infty$.

If A is a quantum system and X is a classical system with alphabet \mathcal{X} , we call $\rho \in \mathcal{S}(XA)$ a cq-state and can expand it as

$$\rho_{XA} = \sum_{x \in \mathcal{X}} |x\rangle\langle x| \otimes \rho_{A,x}$$

for subnormalised $\rho_{A,x} \in \text{Pos}(A)$. For $\Omega \subset \mathcal{X}$, we define the conditional state

$$\rho_{XA|\Omega} = \frac{1}{\text{Pr}_\rho[\Omega]} \sum_{x \in \Omega} |x\rangle\langle x| \otimes \rho_{A,x}, \quad \text{where } \text{Pr}_\rho[\Omega] := \sum_{x \in \Omega} \text{Tr}[\rho_{A,x}].$$

If $\Omega = \{x\}$, we also write $\rho_{XA|x}$ for $\rho_{XA|\Omega}$.

2.2 Rényi divergence and entropy

We will make extensive use of the sandwiched Rényi divergence [MLDS⁺13, WWY14] and quantities associated with it, namely Rényi entropies and channel divergences. We recall the relevant definitions here.

Definition 2.1 (Rényi divergence). For $\rho \in \mathcal{S}(A)$, $\sigma \in \text{Pos}(A)$, and $\alpha \in [1/2, 1) \cup (1, \infty)$ the (sandwiched) Rényi divergence is defined as

$$D_\alpha(\rho \parallel \sigma) := \frac{1}{\alpha - 1} \log \text{Tr} \left[\left(\sigma^{\frac{1-\alpha}{2\alpha}} \rho \sigma^{\frac{1-\alpha}{2\alpha}} \right)^\alpha \right]$$

for $\text{supp}(\rho) \subseteq \text{supp}(\sigma)$, and $+\infty$ otherwise.

From the Rényi divergence, one can define the conditional Rényi entropies as follows (see [Tom15] for more details).

Definition 2.2 (Conditional Rényi entropy). For a bipartite state $\rho_{AB} \in \mathcal{S}(AB)$ and $\alpha \in [1/2, 1) \cup (1, \infty)$, we define the following two conditional Rényi entropies:

$$H_\alpha(A|B)_\rho = -D_\alpha(\rho_{AB} \parallel \mathbb{1}_A \otimes \rho_B) \quad \text{and} \quad H_\alpha^\dagger(A|B)_\rho = \sup_{\sigma_B \in \mathcal{S}(B)} -D_\alpha(\rho_{AB} \parallel \mathbb{1}_A \otimes \sigma_B).$$

From the definition it is clear that $H_\alpha(A|B) \leq H_\alpha^\dagger(A|B)$. Importantly, a relation for the other direction also holds.

Lemma 2.3 ([Tom15, Corollary 5.3]). For $\rho_{AB} \in \mathcal{S}(AB)$ and $\alpha \in (1, 2)$:

$$H_\alpha(A|B)_\rho \geq H_{\frac{1}{2-\alpha}}^\dagger(A|B)_\rho.$$

In the limit $\alpha \rightarrow 1$ the sandwiched Rényi divergence converges to the relative entropy:

$$\lim_{\alpha \rightarrow 1} D_\alpha(\rho \parallel \sigma) = D(\rho \parallel \sigma) = \text{Tr}[\rho(\log \rho - \log \sigma)] .$$

Accordingly, the conditional Rényi entropy converges to the conditional von Neumann entropy:

$$\lim_{\alpha \rightarrow 1} H_\alpha(A|B)_\rho = H(A|B)_\rho = H(AB)_\rho - H(B)_\rho = -\text{Tr}[\rho_{AB} \log \rho_{AB}] + \text{Tr}[\rho_B \log \rho_B] .$$

Conversely, in the limit $\alpha \rightarrow \infty$, the Rényi entropy H_α^\dagger converges to the min-entropy. We will make use of a smoothed version of the min-entropy, which is defined as follows [Ren08].

Definition 2.4 (Smoothed min-entropy). For $\rho_{AB} \in \mathcal{S}(AB)$ and $\varepsilon \in [0, 1]$, the ε -smoothed min-entropy of A conditioned on B is

$$H_{\min}^\varepsilon(A|B)_\rho = -\log \inf_{\tilde{\rho}_{AB} \in \mathcal{B}_\varepsilon(\rho_{AB})} \inf_{\sigma_B \in \mathcal{S}(B)} \left\| \sigma_B^{-\frac{1}{2}} \tilde{\rho}_{AB} \sigma_B^{-\frac{1}{2}} \right\|_\infty ,$$

where $\|\cdot\|_\infty$ denotes the spectral norm and $\mathcal{B}_\varepsilon(\rho_{AB})$ is the ε -ball around ρ_{AB} in term of the purified distance [Tom15].

Finally, we can extend the definition of the Rényi divergence from states to channels. The resulting quantity, the channel divergence (and its regularised version), will play an important role in the rest of the manuscript.

Definition 2.5 (Channel divergence). For $\mathcal{E} \in \text{CPTP}(A, A')$, $\mathcal{F} \in \text{CP}(A, A')$, and $\alpha \in [1/2, 1) \cup (1, \infty)$, the (stabilised) channel divergence is defined as

$$D_\alpha(\mathcal{E} \parallel \mathcal{F}) = \sup_{\omega \in \mathcal{S}(A\tilde{A})} D_\alpha(\mathcal{E}(\omega) \parallel \mathcal{F}(\omega)) , \quad (2.1)$$

where without loss of generality $\tilde{A} \equiv A$. The regularised channel divergence is defined as

$$D_\alpha^{\text{reg}}(\mathcal{E} \parallel \mathcal{F}) := \lim_{n \rightarrow \infty} \frac{1}{n} D_\alpha(\mathcal{E}^{\otimes n} \parallel \mathcal{F}^{\otimes n}) = \sup_n \frac{1}{n} D_\alpha(\mathcal{E}^{\otimes n} \parallel \mathcal{F}^{\otimes n}) .$$

We note that the channel divergence is in general not additive under the tensor product [FFRS20, Proposition 3.1], so the regularised channel divergence can be strictly larger than the non-regularised one, i.e., $D_\alpha^{\text{reg}}(\mathcal{E} \parallel \mathcal{F}) > D_\alpha(\mathcal{E} \parallel \mathcal{F})$. The regularised channel divergence, however, does satisfy an additivity property:

$$D_\alpha^{\text{reg}}(\mathcal{E}^{\otimes k} \parallel \mathcal{F}^{\otimes k}) = \lim_{n \rightarrow \infty} \frac{1}{n} D_\alpha(\mathcal{E}^{\otimes kn} \parallel \mathcal{F}^{\otimes kn}) = k \lim_{n \rightarrow \infty} \frac{1}{n'} D_\alpha(\mathcal{E}^{\otimes n'} \parallel \mathcal{F}^{\otimes n'}) = k D_\alpha^{\text{reg}}(\mathcal{E} \parallel \mathcal{F}) , \quad (2.2)$$

where we switched to the index $n' = kn$ for the second equality.

2.3 Spectral pinching

A key technical tool in our proof will be the use of spectral pinching maps, which are defined as follows (see [Sut18, Chapter 3] for a more detailed introduction).

Definition 2.6 (Spectral pinching map). Let $\rho \in \text{Pos}(A)$ with spectral decomposition $\rho = \sum_{\lambda} \lambda P_{\lambda}$, where $\lambda \in \text{Spec}(\rho) \subset \mathbb{R}_{\geq 0}$ are the distinct eigenvalues of ρ and P_{λ} are mutually orthogonal projectors. The (spectral) pinching map $\mathcal{P}_{\rho} \in \text{CPTP}(A, A)$ associated with ρ is given by

$$\mathcal{P}_{\rho}(\omega) := \sum_{\lambda \in \text{Spec}(\rho)} P_{\lambda} \omega P_{\lambda}.$$

We will need a few basic properties of pinching maps.

Lemma 2.7 (Properties of pinching maps). *For any $\rho, \sigma \in \text{Pos}(A)$, the following properties hold:*

- (i) *Invariance:* $\mathcal{P}_{\rho}(\rho) = \rho$.
- (ii) *Commutation of pinched state:* $[\sigma, \mathcal{P}_{\sigma}(\rho)] = 0$.
- (iii) *Pinching inequality:* $\mathcal{P}_{\sigma}(\rho) \geq \frac{1}{|\text{Spec}(\sigma)|} \rho$.
- (iv) *Commutation of pinching maps:* if $[\rho, \sigma] = 0$, then $\mathcal{P}_{\rho} \circ \mathcal{P}_{\sigma} = \mathcal{P}_{\sigma} \circ \mathcal{P}_{\rho}$.
- (v) *Partial trace:* $\text{Tr}_B[\mathcal{P}_{\rho_A \otimes \mathbb{1}_B}(\omega_{AB})] = \mathcal{P}_{\rho_A}(\omega_A) \quad \forall \omega_{AB} \in \text{Pos}(AB)$.

Proof. Properties (i)–(iii) follow from the definition and [TCR09, Chapter 2.6.3] or [Sut18, Lemma 3.5].

For the fourth statement, note that since $[\rho, \sigma] = 0$, there exists a joint orthonormal eigenbasis $\{|x_i\rangle\}$ of ρ and σ . Let P_{λ} be the projector onto the eigenspace of ρ with eigenvalue λ , and Q_{μ} the projector onto the eigenspace of σ with eigenvalue μ . We can expand

$$P_{\lambda} = \sum_{i \text{ s.t. } \rho|x_i\rangle = \lambda|x_i\rangle} |x_i\rangle\langle x_i| \quad \text{and} \quad Q_{\mu} = \sum_{j \text{ s.t. } \sigma|x_j\rangle = \mu|x_j\rangle} |x_j\rangle\langle x_j|.$$

Since $\{|x_i\rangle\}$ is a family of orthonormal vectors,

$$P_{\lambda} Q_{\mu} = \sum_{\substack{i \text{ s.t. } \rho|x_i\rangle = \lambda|x_i\rangle \\ \text{and } \sigma|x_i\rangle = \mu|x_i\rangle}} |x_i\rangle\langle x_i| = Q_{\mu} P_{\lambda},$$

which implies commutation of the pinching maps.

For the fifth statement, note that if we write $\rho = \sum_{\lambda} \lambda P_{\lambda}$ with eigenprojectors P_{λ} , then the set of eigenprojectors of $\rho_A \otimes \mathbb{1}_B$ is simply $\{P_{\lambda} \otimes \mathbb{1}_B\}$. Hence,

$$\text{Tr}_B[\mathcal{P}_{\rho_A \otimes \mathbb{1}_B}(\omega_{AB})] = \sum_{\lambda} \text{Tr}_B[P_{\lambda} \otimes \mathbb{1}_B \omega_{AB} P_{\lambda} \otimes \mathbb{1}_B] = \sum_{\lambda} P_{\lambda} \text{Tr}_B[\omega_{AB}] P_{\lambda} = \mathcal{P}_{\rho_A}(\omega_A).$$

□

It is often useful to use the pinching map associated with tensor power states, i.e., $\mathcal{P}_{\rho^{\otimes n}}$. This is because for $\rho \in \text{Pos}(A)$, the factor $|\text{Spec}(\rho^{\otimes n})|$ from the pinching inequality (see Lemma 2.7) only scales polynomially in n (see e.g. [Sut18, Remark 3.9]):

$$|\text{Spec}(\rho^{\otimes n})| \leq (n+1)^{\dim(A)-1}. \quad (2.3)$$

In fact, we can show a similar property for all permutation-invariant states, not just tensor product states.

Lemma 2.8. *Let $\rho \in \text{Pos}(A^{\otimes n})$ be permutation invariant and denote $d = \dim(A)$. Then*

$$|\text{Spec}(\rho)| \leq (n + d)^{d(d+1)/2}.$$

Proof. By Schur-Weyl duality, since ρ is permutation-invariant, we have

$$\rho \cong \bigoplus_{\lambda \in \mathcal{I}_{d,n}} \rho(\lambda)_{Q_\lambda} \otimes \mathbb{1}_{P_\lambda},$$

where \cong denotes equality up to unitary conjugation (which leaves the spectrum invariant), $\mathcal{I}_{d,n}$ is the set of Young diagrams with n boxes and at most d rows, Q_λ and P_λ are systems whose details need not concern us, and $\rho(\lambda) \in \text{Pos}(Q_\lambda)$. From this it is clear that

$$|\text{Spec}(\rho)| \leq \sum_{\lambda \in \mathcal{I}_{d,n}} |\text{Spec}(\rho(\lambda))| \leq \sum_{\lambda \in \mathcal{I}_{d,n}} \dim(Q_\lambda).$$

It is known that $|\mathcal{I}_{d,n}| \leq (n + 1)^d$ and $\dim(Q_\lambda) \leq (n + d)^{d(d-1)/2}$ (see e.g. [Har05, Section 6.2]). Hence

$$|\text{Spec}(\rho)| \leq (n + 1)^d (n + d)^{d(d-1)/2} \leq (n + d)^{d(d+1)/2}.$$

□

Corollary 2.9. *Let $\rho, \sigma \in \text{Pos}(A)$ and $d = \dim(A)$. Then*

$$|\text{Spec}(\mathcal{P}_{\rho^{\otimes n}}(\sigma^{\otimes n}))| \leq (n + d)^{d(d+1)/2}.$$

Proof. Since every eigenspace of $\rho^{\otimes n}$ is permutation-invariant, $\mathcal{P}_{\rho^{\otimes n}}(\sigma^{\otimes n})$ is permutation-invariant, too, so we can apply Lemma 2.8. □

3 Strengthened chain rules

One of the crucial properties of entropies are chain rules, which allow us to relate entropies of large composite systems to sums of entropies of the individual subsystems. In this section, we prove two new such chain rules, one for the Rényi divergence (Theorem 3.1, which is a generalisation of [FF21, Corollary 5.1]) and one for the conditional entropy (Lemma 3.6). The chain rule from Lemma 3.6 is the key ingredient for our generalised EAT, to which we will turn our attention in Section 4. Lemma 3.6 plays a similar role for our generalised EAT as [DFR20, Corollary 3.5] does for the original EAT, but while the latter requires a Markov condition, the former does not. As a result, our generalised EAT based on Lemma 3.6 also avoids the Markov condition.

The outline of this section is as follows: we first prove a generalised chain rule for the Rényi divergence (Theorem 3.1). This chain rule contains a regularised channel divergence. As the next step, we show that in the special case of conditional entropies, we can drop the regularisation (Section 3.2). This allows us to derive a chain rule for conditional entropies from the chain rule for channels (Section 3.3).

3.1 Strengthened chain rule for Rényi divergence

The main result of this section is the following chain rule for the Rényi divergence.

Theorem 3.1. *Let $\alpha > 1$, $\rho \in \mathcal{S}(AR)$, $\sigma \in \text{Pos}(AR)$, $\mathcal{E} \in \text{CPTP}(AR, B)$, and $\mathcal{F} \in \text{CP}(AR, B)$. Suppose that there exists $\mathcal{R} \in \text{CP}(A, B)$ such that $\mathcal{F} = \mathcal{R} \circ \text{Tr}_R$. Then*

$$D_\alpha(\mathcal{E}(\rho_{AR}) \parallel \mathcal{F}(\sigma_{AR})) \leq D_\alpha(\rho_A \parallel \sigma_A) + D_\alpha^{\text{reg}}(\mathcal{E} \parallel \mathcal{F}). \quad (3.1)$$

This is a stronger version of an existing chain rule due to [FF21], which we will use in our proof of [Theorem 3.1](#):

Lemma 3.2 ([FF21, Corollary 5.1]). *Let $\alpha > 1$, $\rho \in \mathcal{S}(A)$, $\sigma \in \text{Pos}(A)$, $\mathcal{E} \in \text{CPTP}(A, B)$, and $\mathcal{F} \in \text{CP}(A, B)$. Then*

$$D_\alpha(\mathcal{E}(\rho) \parallel \mathcal{F}(\sigma)) \leq D_\alpha(\rho \parallel \sigma) + D_\alpha^{\text{reg}}(\mathcal{E} \parallel \mathcal{F}). \quad (3.2)$$

The difference between [Theorem 3.1](#) and [Lemma 3.2](#) is that on the r.h.s. of [Equation \(3.1\)](#), we only have the divergence $D_\alpha(\rho_A \parallel \sigma_A)$ between the two reduced states on system A . In contrast, if we used [Equation \(3.2\)](#) with systems AR , then we would get the divergence $D_\alpha(\rho_{AR} \parallel \sigma_{AR})$ between the full states. In particular, the weaker [Lemma 3.2](#) can easily be recovered from [Theorem 3.1](#) by taking the system R to be trivial, in which case the condition $\mathcal{F} = \mathcal{R} \circ \text{Tr}_R$ becomes trivial, too.

While the difference between [Theorem 3.1](#) and [Lemma 3.2](#) may look minor at first sight, the two chain rules can give considerably different results: in general, the data processing inequality ensures that $D_\alpha(\rho_A \parallel \sigma_A) \leq D_\alpha(\rho_{AR} \parallel \sigma_{AR})$, but the gap between the two quantities can be significant, i.e., there exist states for which $D_\alpha(\rho_A \parallel \sigma_A) \ll D_\alpha(\rho_{AR} \parallel \sigma_{AR})$. In such cases, [Theorem 3.1](#) yields a significantly tighter bound. This turns out to be crucial if we want to apply this chain rule repeatedly to get an EAT.

We also note that the statement of [Theorem 3.1](#) is known to be correct also for $\alpha = 1$ [FFRS20, Theorem 3.5]. However, this requires a separate proof and does not follow from [Theorem 3.1](#) as it is currently not known whether the function $\alpha \mapsto D_\alpha^{\text{reg}}(\mathcal{E} \parallel \mathcal{F})$ is continuous in the limit $\alpha \searrow 1$.⁵

We now turn to the proof of [Theorem 3.1](#). The key question for the proof is the following: given states ρ_{AR} and σ_A , does there exist an extension σ_{AR} of σ_A such that $D_\alpha(\rho_A \parallel \sigma_A) = D_\alpha(\rho_{AR} \parallel \sigma_{AR})$? For the special case of $\alpha = 1/2$, an affirmative answer is given by Uhlmann's theorem [Uhl76] (see also [Tom15, Corollary 3.14]). This also holds for $\alpha = \infty$, but not in general for $\alpha \geq 1$ as discussed in [Appendix B](#). The following lemma shows that a similar property still holds for $\alpha > 1$ on a regularised level.

Lemma 3.3. *Consider quantum systems A and R with $d = \dim(A)$. For $n \in \mathbb{N}$, we define $A^n = A_1 \dots A_n$, where A_i are copies of the system A , and likewise $R^n = R_1 \dots R_n$. Then for $\rho \in \mathcal{S}(AR)$, $\sigma \in \text{Pos}(A)$, and $\alpha > 1$ we have*

$$D_\alpha(\rho_A \parallel \sigma_A) \leq \inf_{\hat{\sigma}_{A^n R^n} \text{ s.t. } \hat{\sigma}_{A^n} = \sigma_A^{\otimes n}} \frac{1}{n} D_\alpha(\rho_{AR}^{\otimes n} \parallel \hat{\sigma}_{A^n R^n}) \leq D_\alpha(\rho_A \parallel \sigma_A) + \frac{\alpha}{\alpha - 1} \frac{d(d+1) \log(n+d)}{n}.$$

Proof. The inequality

$$D_\alpha(\rho_A \parallel \sigma_A) \leq \inf_{\hat{\sigma}_{A^n R^n} \text{ s.t. } \hat{\sigma}_{A^n} = \sigma_A^{\otimes n}} \frac{1}{n} D_\alpha(\rho_{AR}^{\otimes n} \parallel \hat{\sigma}_{A^n R^n})$$

⁵It is well-known [TCR09, Lemma 8] that $\lim_{\alpha \searrow 1} D_\alpha(\mathcal{E} \parallel \mathcal{F}) = D(\mathcal{E} \parallel \mathcal{F})$, but it is unclear whether the same holds for the regularised quantity.

follows directly from the data processing inequality for taking the partial trace over R^n , and additivity of D_α under tensor product [Tom15].

For the other direction, we consider n -fold tensor copies of ρ_{AR} and σ_A , which we denote by $\rho_{A^n R^n} = \rho_{A_1 R_1} \otimes \cdots \otimes \rho_{A_n R_n}$ and $\sigma_{A^n} = \sigma_{A_1} \otimes \cdots \otimes \sigma_{A_n}$. We define the following two pinched states

$$\rho'_{A^n R^n} = \mathcal{P}_{\sigma_{A^n} \otimes \mathbb{1}_{R^n}}(\rho_{A^n R^n}) \quad \text{and} \quad \hat{\rho}_{A^n R^n} = \mathcal{P}_{\rho'_{A^n} \otimes \mathbb{1}_{R^n}}(\rho'_{A^n R^n}). \quad (3.3)$$

By definition of $\hat{\rho}_{A^n R^n}$ and using the pinching inequality (see Lemma 2.7(iii)) twice, we have

$$\rho_{A^n R^n} \leq |\text{Spec}(\sigma_{A^n})| |\text{Spec}(\rho'_{A^n})| \hat{\rho}_{A^n R^n}.$$

Using the operator monotonicity of the sandwiched Rényi divergence in the first argument [Tom15] we find for any state $\hat{\sigma}_{A^n R^n}$

$$\frac{1}{n} D_\alpha(\rho_{AR}^{\otimes n} \parallel \hat{\sigma}_{A^n R^n}) \leq \frac{1}{n} D_\alpha(\hat{\rho}_{A^n R^n} \parallel \hat{\sigma}_{A^n R^n}) + \frac{1}{n} \frac{\alpha}{\alpha - 1} \eta(n), \quad (3.4)$$

with the error term

$$\eta(n) = \log |\text{Spec}(\sigma_{A^n})| + \log |\text{Spec}(\rho'_{A^n})|.$$

To prove the lemma, we now need to bound the error term $\eta(n)$ and construct a specific choice for $\hat{\sigma}_{A^n R^n}$ for which $\hat{\sigma}_{A^n} = \sigma_A^{\otimes n}$ and $\frac{1}{n} D_\alpha(\hat{\rho}_{A^n R^n} \parallel \hat{\sigma}_{A^n R^n}) \leq D_\alpha(\rho_A \parallel \sigma_A)$. We first bound $\eta(n)$. Since $\sigma_{A^n} = \sigma_A^{\otimes n}$, we have from Equation (2.3) that $|\text{Spec}(\sigma_{A^n})| \leq (n+1)^{d-1}$, where $d = \dim(A)$. To bound $|\text{Spec}(\rho'_{A^n})|$, we note that by Equation (3.3) and Lemma 2.7(v)

$$\rho'_{A^n} = \text{Tr}_{R^n} [\mathcal{P}_{\sigma_{A^n} \otimes \mathbb{1}_{R^n}}(\rho_{A^n R^n})] = \mathcal{P}_{\sigma_{A^n}}(\rho_{A^n}) = \mathcal{P}_{\sigma_A^{\otimes n}}(\rho_A^{\otimes n}). \quad (3.5)$$

We can therefore use Corollary 2.9 to obtain $|\text{Spec}(\rho'_{A^n})| \leq (n+d)^{d(d+1)/2}$. Hence,

$$\eta(n) \leq d(d+1) \log(n+d). \quad (3.6)$$

It thus remains to construct $\hat{\sigma}_{A^n R^n}$ satisfying the properties mentioned above. To do so we first establish a number of commutation statements.

- (i) From Lemma 2.7(ii) we have that $[\hat{\rho}_{A^n R^n}, \rho'_{A^n} \otimes \mathbb{1}_{R^n}] = 0$. Recalling the definition of ρ' from Equation (3.3), we get

$$\hat{\rho}_{A^n} = \text{Tr}_{R^n} [\mathcal{P}_{\rho'_{A^n} \otimes \mathbb{1}_{R^n}}(\rho'_{A^n R^n})] = \mathcal{P}_{\rho'_{A^n}}(\rho'_{A^n}) = \rho'_{A^n}, \quad (3.7)$$

where the final step uses Lemma 2.7(i). As a result we find

$$[\hat{\rho}_{A^n R^n}, \hat{\rho}_{A^n} \otimes \mathbb{1}_{R^n}] = 0. \quad (3.8)$$

- (ii) From Lemma 2.7(ii) we have that $[\rho'_{A^n R^n}, \sigma_{A^n} \otimes \mathbb{1}_{R^n}] = 0$. Taking the partial trace over R^n , this implies $[\rho'_{A^n}, \sigma_{A^n}] = 0$, so by Lemma 2.7(iv) and Equation (3.3)

$$\hat{\rho}_{A^n R^n} = \mathcal{P}_{\rho'_{A^n} \otimes \mathbb{1}_{R^n}}(\mathcal{P}_{\sigma_{A^n} \otimes \mathbb{1}_{R^n}}(\rho_{A^n R^n})) = \mathcal{P}_{\sigma_{A^n} \otimes \mathbb{1}_{R^n}}(\mathcal{P}_{\rho'_{A^n} \otimes \mathbb{1}_{R^n}}(\rho_{A^n R^n})).$$

Therefore, by Lemma 2.7(ii),

$$[\hat{\rho}_{A^n R^n}, \sigma_{A^n} \otimes \mathbb{1}_{R^n}] = 0. \quad (3.9)$$

(iii) Taking the partial trace over R^n in Equation (3.9), we get

$$[\hat{\rho}_{A^n}, \sigma_{A^n}] = 0. \quad (3.10)$$

Having established these commutation relations, we define $\mathcal{T} \in \text{CPTP}(A^n, A^n R^n)$ by⁶

$$\mathcal{T}(\omega_{A^n}) = \hat{\rho}_{A^n R^n}^{1/2} \hat{\rho}_{A^n}^{-1/2} \omega_{A^n} \hat{\rho}_{A^n}^{-1/2} \hat{\rho}_{A^n R^n}^{1/2}.$$

By construction,

$$\mathcal{T}(\hat{\rho}_{A^n}) = \hat{\rho}_{A^n R^n}. \quad (3.11)$$

We define

$$\hat{\sigma}_{A^n R^n} = \mathcal{T}(\sigma_{A^n}). \quad (3.12)$$

To see that this is a valid choice of $\hat{\sigma}$, i.e., that $\hat{\sigma}_{A^n} = \sigma_{A^n} = \sigma_A^{\otimes n}$, we use Equation (3.8), Equation (3.9), and Equation (3.10) to find

$$\hat{\sigma}_{A^n} = \text{Tr}_{R^n} \left[\hat{\rho}_{A^n R^n}^{1/2} \hat{\rho}_{A^n}^{-1/2} \sigma_{A^n} \hat{\rho}_{A^n}^{-1/2} \hat{\rho}_{A^n R^n}^{1/2} \right] = \text{Tr}_{R^n} \left[\hat{\rho}_{A^n R^n} \hat{\rho}_{A^n}^{-1} \sigma_{A^n} \right] = \sigma_{A^n}.$$

Using Equation (3.11) and Equation (3.12) followed by the data processing inequality [Tom15], we obtain

$$\frac{1}{n} D_\alpha(\hat{\rho}_{A^n R^n} \parallel \hat{\sigma}_{A^n R^n}) = \frac{1}{n} D_\alpha(\mathcal{T}(\hat{\rho}_{A^n}) \parallel \mathcal{T}(\sigma_{A^n})) \leq \frac{1}{n} D_\alpha(\hat{\rho}_{A^n} \parallel \sigma_{A^n}). \quad (3.13)$$

By Equation (3.7) and Equation (3.3) we have $\hat{\rho}_{A^n} = \rho'_{A^n} = \mathcal{P}_{\sigma_{A^n}}(\rho_{A^n})$. Therefore, continuing from Equation (3.13) and using $\sigma_{A^n} = \mathcal{P}_{\sigma_{A^n}}(\sigma_{A^n})$ followed by the data processing inequality gives

$$\frac{1}{n} D_\alpha(\hat{\rho}_{A^n R^n} \parallel \hat{\sigma}_{A^n R^n}) \leq \frac{1}{n} D_\alpha(\rho_{A^n} \parallel \sigma_{A^n}) = \frac{1}{n} D_\alpha(\rho_A^{\otimes n} \parallel \sigma_A^{\otimes n}) = D_\alpha(\rho_A \parallel \sigma_A).$$

Inserting this and our error bound from Equation (3.6) into Equation (3.4) proves the desired statement. \square

With this, we can now prove Theorem 3.1.

Proof of Theorem 3.1. Because D_α is additive under tensor products, for any $n \in \mathbb{N}$ we have

$$\begin{aligned} D_\alpha(\mathcal{E}(\rho_{AR}) \parallel \mathcal{F}(\sigma_{AR})) &= \frac{1}{n} D_\alpha(\mathcal{E}^{\otimes n}(\rho_{AR}^{\otimes n}) \parallel \mathcal{F}^{\otimes n}(\sigma_{AR}^{\otimes n})) \\ &= \inf_{\hat{\sigma}_{A^n R^n} \text{ s.t. } \hat{\sigma}_{A^n} = \sigma_A^{\otimes n}} \frac{1}{n} D_\alpha(\mathcal{E}^{\otimes n}(\rho_{AR}^{\otimes n}) \parallel \mathcal{F}^{\otimes n}(\hat{\sigma}_{A^n R^n})), \end{aligned} \quad (3.14)$$

where the second equality holds because $\mathcal{F} = \mathcal{R} \circ \text{Tr}_R$, so $\mathcal{F}^{\otimes n}(\sigma_{AR}^{\otimes n}) = \mathcal{F}^{\otimes n}(\hat{\sigma}_{A^n R^n})$ for any $\hat{\sigma}_{A^n R^n}$ that satisfies $\hat{\sigma}_{A^n} = \sigma_A^{\otimes n}$. From the chain rule in Lemma 3.2 we get that for any $\hat{\sigma}_{A^n R^n}$:

$$\begin{aligned} \frac{1}{n} D_\alpha(\mathcal{E}^{\otimes n}(\rho_{AR}^{\otimes n}) \parallel \mathcal{F}^{\otimes n}(\hat{\sigma}_{A^n R^n})) &\leq \frac{1}{n} D_\alpha(\rho_{AR}^{\otimes n} \parallel \hat{\sigma}_{A^n R^n}) + \frac{1}{n} D_\alpha^{\text{reg}}(\mathcal{E}^{\otimes n} \parallel \mathcal{F}^{\otimes n}) \\ &= \frac{1}{n} D_\alpha(\rho_{AR}^{\otimes n} \parallel \hat{\sigma}_{A^n R^n}) + D_\alpha^{\text{reg}}(\mathcal{E} \parallel \mathcal{F}), \end{aligned}$$

⁶In case $\hat{\rho}_{A^n}$ does not have full support, we only take the inverse on the support of $\hat{\rho}_{A^n}$.

where for the second line we used additivity of the regularised channel divergence (see Equation (2.2)). Combining this with Equation (3.14), we get

$$D_\alpha(\mathcal{E}(\rho_{AR}) \parallel \mathcal{F}(\sigma_{AR})) \leq \inf_{\hat{\sigma}_{A^n R^n} \text{ s.t. } \hat{\sigma}_{A^n} = \sigma_A^{\otimes n}} \frac{1}{n} D_\alpha(\mathcal{E}^{\otimes n}(\rho_{AR}^{\otimes n}) \parallel \mathcal{F}^{\otimes n}(\hat{\sigma}_{A^n R^n})) + D_\alpha^{\text{reg}}(\mathcal{E} \parallel \mathcal{F}).$$

Taking $n \rightarrow \infty$, the theorem then follows from Lemma 3.3. \square

3.2 Removing the regularisation

The chain rule presented in Theorem 3.1 contains a regularised channel divergence term, which cannot be computed easily and whose behaviour as $\alpha \searrow 1$ is not understood. In this section we show that in the specific case relevant for entropy accumulation, this regularisation can be removed. From this, we then derive a chain rule for Rényi entropies in Lemma 3.6.

Definition 3.4 (Replacer map). The replacer map $\mathcal{S}_A \in \text{CP}(A, A)$ is defined by its action on an arbitrary state ω_{AR} :

$$\mathcal{S}_A(\omega_{AR}) = \mathbb{1}_A \otimes \omega_R.$$

Lemma 3.5. Let $\alpha \in (1, 2)$, $\mathcal{E} \in \text{CPTP}(AR, A'R')$, and $\mathcal{F} = \mathcal{S}_{A'} \circ \mathcal{E}$, where $\mathcal{S}_{A'}$ is the replacer map. Then we have

$$D_\alpha^{\text{reg}}(\mathcal{E} \parallel \mathcal{F}) \leq D_{\frac{1}{2-\alpha}}(\mathcal{E} \parallel \mathcal{F}).$$

Proof. Due to the choice of \mathcal{F} , we have that for any state ψ^n :

$$D_\alpha(\mathcal{E}^{\otimes n}(\psi^n) \parallel \mathcal{F}^{\otimes n}(\psi^n)) = -H_\alpha((A')^n | (R')^n \tilde{R}^n)_{\mathcal{E}^{\otimes n}(\psi^n)}.$$

From [LKDW18, Proposition II.4] and [Ren08, Lemma 4.2.2] we know that for every n , there exists a symmetric pure state $|\hat{\psi}^n\rangle \in \text{Sym}^n(AR\tilde{R})$ (with $\tilde{R} \equiv AR$) such that

$$D_\alpha(\mathcal{E}^{\otimes n} \parallel \mathcal{F}^{\otimes n}) = D_\alpha(\mathcal{E}^{\otimes n}(\hat{\psi}^n) \parallel \mathcal{F}^{\otimes n}(\hat{\psi}^n)) = -H_\alpha((A')^n | (R')^n \tilde{R}^n)_{\mathcal{E}^{\otimes n}(\hat{\psi}^n)},$$

where $\hat{\psi}^n = |\hat{\psi}^n\rangle\langle\hat{\psi}^n|$ and the supremum in the definition of the channel divergence is achieved because the conditional entropy is continuous in the state. Let $d = \dim(AR\tilde{R})$ and $g_{n,d} = \dim(\text{Sym}^n(AR\tilde{R})) \leq (n+1)^{d^2-1}$. We define the state

$$\tau_{A^n R^n \tilde{R}^n}^n = \int \mu(\sigma_{AR\tilde{R}}) \sigma_{AR\tilde{R}}^{\otimes n}, \quad (3.15)$$

where μ is the Haar measure on pure states. We now claim that in the limit $n \rightarrow \infty$, we can essentially replace the optimizer $\hat{\psi}_{A^n R^n \tilde{R}^n}^n$ by the state $\tau_{A^n R^n \tilde{R}^n}^n$ in Equation (3.15). More precisely, we claim that

$$\lim_{n \rightarrow \infty} \frac{1}{n} H_\alpha((A')^n | (R')^n \tilde{R}^n)_{\mathcal{E}^{\otimes n}(\hat{\psi}^n)} \geq \lim_{n \rightarrow \infty} \frac{1}{n} H_{\frac{1}{2-\alpha}}((A')^n | (R')^n \tilde{R}^n)_{\mathcal{E}^{\otimes n}(\tau^n)}. \quad (3.16)$$

To show this, we first use Lemma 2.3 to get

$$H_\alpha((A')^n | (R')^n \tilde{R}^n)_{\mathcal{E}^{\otimes n}(\hat{\psi}^n)} \geq H_{\frac{1}{2-\alpha}}^\dagger((A')^n | (R')^n \tilde{R}^n)_{\mathcal{E}^{\otimes n}(\hat{\psi}^n)}.$$

It is known that $\tau_{A^n R^n \tilde{R}^n}^n$ is the maximally mixed state on $\text{Sym}^n(AR\tilde{R})$ (see e.g. [CKR09]). Therefore,

$$\rho_{A^n R^n \tilde{R}^n}^n := \frac{g_{n,d} \tau^n - \hat{\psi}^n}{g_{n,d} - 1}$$

is a valid quantum state (i.e. positive and normalised). Hence, we can write

$$\tau^n = \left(1 - \frac{1}{g_{n,d}}\right) \rho^n + \frac{1}{g_{n,d}} \hat{\psi}^n.$$

Using [DFR20, Lemma B.5], it follows that

$$\frac{1}{n} H_{\frac{1}{2-\alpha}}^\uparrow \left((A')^n | (R')^n \tilde{R}^n \right)_{\mathcal{E}^{\otimes n}(\hat{\psi}^n)} \geq \frac{1}{n} H_{\frac{1}{2-\alpha}}^\uparrow \left((A')^n | (R')^n \tilde{R}^n \right)_{\mathcal{E}^{\otimes n}(\tau^n)} - \frac{\alpha}{\alpha-1} \frac{\log(g_{n,d})}{n}.$$

Since $\frac{\log(g_{n,d})}{n} \leq (d^2 - 1) \frac{\log n}{n}$ vanishes as $n \rightarrow \infty$, taking the limit and using $H_{\frac{1}{2-\alpha}}^\uparrow(\cdot|\cdot) \geq H_{\frac{1}{2-\alpha}}(\cdot|\cdot)$ proves Equation (3.16).

Having established Equation (3.16), we can now conclude the proof of the lemma as follows

$$\begin{aligned} D_\alpha^{\text{reg}}(\mathcal{E} \| \mathcal{F}) &= - \lim_{n \rightarrow \infty} \frac{1}{n} H_\alpha \left((A')^n | (R')^n \tilde{R}^n \right)_{\mathcal{E}^{\otimes n}(\hat{\psi}^n)} \\ &\leq - \lim_{n \rightarrow \infty} \frac{1}{n} H_{\frac{1}{2-\alpha}} \left((A')^n | (R')^n \tilde{R}^n \right)_{\mathcal{E}^{\otimes n}(\tau^n)} \\ &= \lim_{n \rightarrow \infty} \frac{1}{n} D_{\frac{1}{2-\alpha}} \left(\mathcal{E}^{\otimes n} \left(\int \mu(\sigma_{AR\tilde{R}}) \sigma_{AR\tilde{R}}^{\otimes n} \right) \left\| \mathcal{F}^{\otimes n} \left(\int \mu(\sigma_{AR\tilde{R}}) \sigma_{AR\tilde{R}}^{\otimes n} \right) \right\| \right) \\ &\leq \lim_{n \rightarrow \infty} \sup_{\sigma_{AR\tilde{R}} \in \mathcal{S}(AR\tilde{R})} \frac{1}{n} D_{\frac{1}{2-\alpha}} \left(\mathcal{E}^{\otimes n} \left(\sigma_{AR\tilde{R}}^{\otimes n} \right) \left\| \mathcal{F}^{\otimes n} \left(\sigma_{AR\tilde{R}}^{\otimes n} \right) \right\| \right) \\ &= D_{\frac{1}{2-\alpha}}(\mathcal{E} \| \mathcal{F}), \end{aligned}$$

where we used joint quasi-convexity [Tom15, Proposition 4.17] in the fourth line and additivity under tensor products in the last line. \square

3.3 Strengthened chain rule for conditional Rényi entropy

We next combine Theorem 3.1 with Lemma 3.5 to derive a new chain rule for the conditional Rényi entropy which then allows us to prove the generalised EAT in Section 4.

Lemma 3.6. *Let $\alpha \in (1, 2)$, $\rho \in \mathcal{S}(ARE)$, and $\mathcal{M} \in \text{CPTP}(RE, A'R'E')$ such that there exists $\mathcal{R} \in \text{CPTP}(E, E')$ such that $\text{Tr}_{A'R'} \circ \mathcal{M} = \mathcal{R} \circ \text{Tr}_R$. Then*

$$H_\alpha(AA'|E')_{\mathcal{M}(\rho)} \geq H_\alpha(A|E)_\rho + \inf_{\omega \in \mathcal{S}(RE\tilde{E})} H_{\frac{1}{2-\alpha}}(A'|E\tilde{E})_{\mathcal{M}(\omega)} \quad (3.17)$$

for a purifying system $\tilde{E} \equiv RE$.

Proof. We define the following maps⁷

$$\begin{aligned} \mathcal{N} &= \mathcal{S}_{A'} \circ \mathcal{M} && \in \text{CP}(RE, A'R'E'), \\ \tilde{\mathcal{M}} &= \text{id}_A \otimes \text{Tr}_{R'} \circ \mathcal{M} && \in \text{CPTP}(ARE, AA'E'), \\ \tilde{\mathcal{N}} &= \mathcal{S}_{A'} \circ \tilde{\mathcal{M}} && \in \text{CP}(ARE, AA'E'). \end{aligned}$$

⁷The map \mathcal{M} in the theorem statement is also implicitly tensored with an identity map on A , but for the definition of $\tilde{\mathcal{M}}$ we make this explicit to avoid confusion when applying Theorem 3.1.

Note that in Equation (3.17), we can replace \mathcal{M} by $\tilde{\mathcal{M}}$, as the system R' does not appear in Equation (3.17). With $\sigma_{ARE} = \mathbb{1}_A \otimes \rho_{RE}$ and $\tilde{\mathcal{N}} = \mathcal{S}_{A'} \circ \tilde{\mathcal{M}}$, we can write

$$-H_\alpha(AA'|E')_{\mathcal{M}(\rho)} = D_\alpha(\tilde{\mathcal{M}}(\rho_{ARE}) \parallel \tilde{\mathcal{N}}(\sigma_{ARE})) .$$

We now claim that there exists a map $\tilde{\mathcal{R}} \in \text{CP}(AE, AA'E)$ such that $\tilde{\mathcal{N}} = \tilde{\mathcal{R}} \circ \text{Tr}_R$. To see this, observe that by assumption, $\text{Tr}_{A'} \circ \tilde{\mathcal{M}} = \text{id}_A \otimes \mathcal{R} \circ \text{Tr}_R$ for some $\mathcal{R} \in \text{CP}(E, E')$. Then, we can define $\tilde{\mathcal{R}} \in \text{CP}(AE, AA'E)$ by its action on an arbitrary state ω_{AE} :

$$\tilde{\mathcal{R}}(\omega_{AE}) := \mathbb{1}_{A'} \otimes (\text{id}_A \otimes \mathcal{R})(\omega_{AE}) = \mathbb{1}_{A'} \otimes \text{Tr}_{A'} \circ \tilde{\mathcal{M}}(\omega_{AE}) = \tilde{\mathcal{N}}(\omega_{AE})$$

for any extension ω_{ARE} of ω_{AE} . Therefore, we can apply Theorem 3.1 to find

$$D_\alpha(\tilde{\mathcal{M}}(\rho_{ARE}) \parallel \tilde{\mathcal{N}}(\sigma_{ARE})) \leq D_\alpha(\rho_{AE} \parallel \sigma_{AE}) + D_\alpha^{\text{reg}}(\tilde{\mathcal{M}} \parallel \tilde{\mathcal{N}}) .$$

By definition of σ , we have $D_\alpha(\rho_{AE} \parallel \sigma_{AE}) = -H_\alpha(A|E)_\rho$. Since the channel divergence is stabilised, tensoring with id_A has no effect, i.e.,

$$D_\alpha^{\text{reg}}(\tilde{\mathcal{M}} \parallel \tilde{\mathcal{N}}) = D_\alpha^{\text{reg}}(\text{Tr}_{R'} \circ \mathcal{M} \parallel \text{Tr}_{R'} \circ \mathcal{N}) = D_\alpha^{\text{reg}}(\text{Tr}_{R'} \circ \mathcal{M} \parallel \mathcal{S}_{A'} \circ \text{Tr}_{R'} \circ \mathcal{M}) .$$

To this, we can apply Lemma 3.5 and obtain

$$D_\alpha^{\text{reg}}(\tilde{\mathcal{M}} \parallel \tilde{\mathcal{N}}) \leq D_{\frac{1}{2-\alpha}}(\text{Tr}_{R'} \circ \mathcal{M} \parallel \mathcal{S}_{A'} \circ \text{Tr}_{R'} \circ \mathcal{M}) = - \inf_{\omega \in \mathcal{S}(RE\tilde{E})} H_{\frac{1}{2-\alpha}}(A'|E'\tilde{E})_{\mathcal{M}(\omega)}$$

with $\tilde{E} \equiv RE$. Combining all the steps yields the desired statement. \square

4 Generalised entropy accumulation

We are finally ready to state and prove the main result of this work which is a generalisation of the EAT proven in [DFR20]. We first state a simple version of this theorem, which follows readily from the chain rule Lemma 3.6 and captures the essential feature of entropy accumulation: the min-entropy of a state $\mathcal{M}_n \circ \dots \circ \mathcal{M}_1(\rho)$ produced by applying a sequence of n channels can be lower-bounded by a sum of entropy contributions of each channel \mathcal{M}_i . However, for practical applications, it is desirable not to consider the state $\mathcal{M}_n \circ \dots \circ \mathcal{M}_1(\rho)$, but rather that state conditioned on some classical event, for example “success” in a key distribution protocol – a concept called “testing”. Analogously to [DFR20], we present an EAT adapted to that setting in Section 4.2.

4.1 Generalised EAT

Theorem 4.1 (Generalised EAT). *Consider a sequence of channels $\mathcal{M}_i \in \text{CPTP}(R_{i-1}E_{i-1}, A_iR_iE_i)$ such that for all $i \in \{1, \dots, n\}$, there exists $\mathcal{R}_i \in \text{CPTP}(E_{i-1}, E_i)$ such that $\text{Tr}_{A_iR_i} \circ \mathcal{M}_i = \mathcal{R}_i \circ \text{Tr}_{R_{i-1}}$. Then for any $\varepsilon \in (0, 1)$ and any $\rho_{R_0E_0} \in \mathcal{S}(R_0E_0)$*

$$H_{\min}^\varepsilon(A^n|E_n)_{\mathcal{M}_n \circ \dots \circ \mathcal{M}_1(\rho_{R_0E_0})} \geq \sum_{i=1}^n \inf_{\omega \in \mathcal{S}(R_{i-1}E_{i-1}\tilde{E}_{i-1})} H(A_i|E_i\tilde{E}_{i-1})_{\mathcal{M}_i(\omega)} - O(\sqrt{n})$$

for a purifying system $\tilde{E}_{i-1} \equiv R_{i-1}E_{i-1}$.

Proof. By [DFR20, Lemma B.10], we have for $\alpha \in (1, 2)$

$$H_{\min}^{\varepsilon}(A_1^n | E_n)_{\mathcal{M}_n \circ \dots \circ \mathcal{M}_1(\rho_{R_0 E_0})} \geq H_{\alpha}(A_1^n | E_n)_{\mathcal{M}_n \circ \dots \circ \mathcal{M}_1(\rho_{R_0 E_0})} - \frac{g(\varepsilon)}{\alpha - 1}$$

with $g(\varepsilon) = \log(1 - \sqrt{1 - \varepsilon^2})$. From Lemma 3.6, we have

$$\begin{aligned} H_{\alpha}(A_1^n | E_n)_{\mathcal{M}_n \circ \dots \circ \mathcal{M}_1(\rho_{R_0 E_0})} \\ \geq H_{\alpha}(A_1^{n-1} | E_{n-1})_{\mathcal{M}_{n-1} \circ \dots \circ \mathcal{M}_1(\rho_{R_0 E_0})} + \inf_{\omega \in \mathcal{S}(R_{n-1} E_{n-1} \tilde{E}_{n-1})} H_{\frac{1}{2-\alpha}}(A_n | E_n \tilde{E}_{n-1})_{\mathcal{M}_n(\omega)}. \end{aligned}$$

Repeating this step $n - 1$ times, we get

$$\begin{aligned} H_{\alpha}(A_1^n | E_n)_{\mathcal{M}_n \circ \dots \circ \mathcal{M}_1(\rho_{R_0 E_0})} &\geq H_{\alpha}(A_1 | E_1)_{\mathcal{M}_1(\rho_{R_0 E_0})} + \sum_{i=2}^n \inf_{\omega \in \mathcal{S}(R_{i-1} E_{i-1} \tilde{E}_{i-1})} H_{\frac{1}{2-\alpha}}(A_i | E_i \tilde{E}_{i-1})_{\mathcal{M}_i(\omega)} \\ &\geq \sum_{i=1}^n \inf_{\omega \in \mathcal{S}(R_{i-1} E_{i-1} \tilde{E}_{i-1})} H_{\frac{1}{2-\alpha}}(A_i | E_i \tilde{E}_{i-1})_{\mathcal{M}_i(\omega)}, \end{aligned}$$

where the final step uses the monotonicity of the Rényi divergence in α [Tom15, Corollary 4.3]. From [DFR20, Lemma B.9] we have for each $i \in \{1, \dots, n\}$ and α sufficiently close to 1,

$$\begin{aligned} \inf_{\omega \in \mathcal{S}(R_{i-1} E_{i-1} \tilde{E}_{i-1})} H_{\frac{1}{2-\alpha}}(A_i | E_i \tilde{E}_{i-1})_{\mathcal{M}_i(\omega)} \\ \geq \inf_{\omega \in \mathcal{S}(R_{i-1} E_{i-1} \tilde{E}_{i-1})} H(A_i | E_i \tilde{E}_{i-1})_{\mathcal{M}_i(\omega)} - \frac{\alpha - 1}{2 - \alpha} \log^2(1 + 2 \dim(A_i)). \end{aligned}$$

Setting $d_A = \max_i \dim(A_i)$ and combining the previous steps, we obtain

$$\begin{aligned} H_{\min}(A_1^n | E_n)_{\mathcal{M}_n \circ \dots \circ \mathcal{M}_1(\rho_{R_0 E_0})} \\ \geq \sum_{i=1}^n \inf_{\omega_i \in \mathcal{S}(R_{i-1} E_{i-1} \tilde{E}_{i-1})} H(A_i | E_i \tilde{E}_{i-1})_{\mathcal{M}_i(\omega_i)} - n \frac{\alpha - 1}{2 - \alpha} \log^2(1 + 2d_A) - \frac{g(\varepsilon)}{\alpha - 1}. \end{aligned}$$

Using $\alpha = 1 + O(1/\sqrt{n})$ yields the result. \square

4.2 Generalised EAT with testing

In this section, we will extend Theorem 4.1 to include the possibility of “testing”, i.e., of computing the min-entropy of a cq-state conditioned on some classical event. This analysis is almost identical to that of [DF19]; we give the full proof for completeness, but will appeal to [DF19] for specific tight bounds. The resulting EAT (Theorem 4.3) has (almost) the same tight bounds as the result in [DF19], but replaces the Markov condition with the more general non-signalling condition. Hence, relaxing the Markov condition does not result in a significant loss in parameters (including second-order terms).

Consider a sequence of channels $\mathcal{M}_i \in \text{CPTP}(R_{i-1} E_{i-1}, C_i A_i R_i E_i)$ for $i \in \{1, \dots, n\}$, where C_i are classical systems with common alphabet \mathcal{C} . We require that these channels \mathcal{M}_i satisfy the following condition: defining $\mathcal{M}'_i = \text{Tr}_{C_i} \circ \mathcal{M}_i$, there exists a channel $\mathcal{T} \in \text{CPTP}(A^n E_n, C^n A^n E_n)$ such that $\mathcal{M}_n \circ \dots \circ \mathcal{M}_1 = \mathcal{T} \circ \mathcal{M}'_n \circ \dots \circ \mathcal{M}'_1$ and \mathcal{T} has the form

$$\mathcal{T}(\omega_{A^n E_n}) = \sum_{y \in \mathcal{Y}, z \in \mathcal{Z}} (\Pi_{A^n}^{(y)} \otimes \Pi_{E_n}^{(z)}) \omega_{A^n E_n} (\Pi_{A^n}^{(y)} \otimes \Pi_{E_n}^{(z)}) \otimes |r(y, z)\rangle\langle r(y, z)|_{C^n}, \quad (4.1)$$

where $\{\Pi_{A^n}^{(y)}\}_y$ and $\{\Pi_{E_n}^{(z)}\}_z$ are families of mutually orthogonal projectors on A^n and E_n , and $r : \mathcal{Y} \times \mathcal{Z} \rightarrow \mathcal{C}$ is a deterministic function. Intuitively, this condition says that the classical statistics can be reconstructed “in a projective way” from systems A^n and E_n at the end of the protocol. In particular, this requirement is always satisfied if the statistics are computed from classical information contained in A^n and E_n , which is the case for many applications. We note that the statistics are still generated in a round-by-round manner; Equation (4.1) merely asserts that they could be *reconstructed* from the final state.

Let \mathbb{P} be the set of probability distributions on the alphabet \mathcal{C} of C_i , and let \tilde{E}_{i-1} be a system isomorphic to $R_{i-1}E_{i-1}$. For any $q \in \mathbb{P}$ we define the set of states

$$\Sigma_i(q) = \left\{ \nu_{C_i A_i R_i E_i \tilde{E}_{i-1}} = \mathcal{M}_i(\omega_{R_{i-1} E_{i-1} \tilde{E}_{i-1}}) \mid \omega \in \mathcal{S}(R_{i-1} E_{i-1} \tilde{E}_{i-1}) \text{ and } \nu_{C_i} = q \right\}, \quad (4.2)$$

where ν_{C_i} denotes the probability distribution over \mathcal{C} with the probabilities given by $\Pr[c] = \langle c | \nu_{C_i} | c \rangle$. In other words, $\Sigma_i(q)$ is the set of states that can be produced at the output of the channel \mathcal{M}_i and whose reduced state on C_i is equal to the probability distribution q .

Definition 4.2. A function $f : \mathbb{P} \rightarrow \mathbb{R}$ is called a *min-tradeoff function* for $\{\mathcal{M}_i\}$ if it satisfies

$$f(q) \leq \min_{v \in \Sigma_i(q)} H(A_i | E_i \tilde{E}_{i-1})_v \quad \forall i = 1, \dots, n.$$

Note that if $\Sigma_i(q) = \emptyset$, then $f(q)$ can be chosen arbitrarily.

Our result will depend on some simple properties of the tradeoff function, namely the maximum and minimum of f , the minimum of f over valid distributions, and the maximum variance of f :

$$\begin{aligned} \text{Max}(f) &:= \max_{q \in \mathbb{P}} f(q), \\ \text{Min}(f) &:= \min_{q \in \mathbb{P}} f(q), \\ \text{Min}_\Sigma(f) &:= \min_{q: \Sigma(q) \neq \emptyset} f(q), \\ \text{Var}(f) &:= \max_{q: \Sigma(q) \neq \emptyset} \sum_{x \in \mathcal{C}} q(x) f(\delta_x)^2 - \left(\sum_{x \in \mathcal{C}} q(x) f(\delta_x) \right)^2, \end{aligned}$$

where $\Sigma(q) = \bigcup_i \Sigma_i(q)$ and δ_x is the distribution with all the weight on element x . We write $\text{freq}(C^n)$ for the distribution on \mathcal{C} defined by $\text{freq}(C^n)(c) = \frac{|\{i \in \{1, \dots, n\} : C_i = c\}|}{n}$. We also recall that in this context, an event Ω is defined by a subset of \mathcal{C}^n , and for a state $\rho_{C^n A^n E_n R_n}$ we write $\Pr_\rho[\Omega] = \sum_{c^n \in \Omega} \text{Tr}[\rho_{A_1^n E_n R_n, c^n}]$ for the probability of the event Ω and

$$\rho_{C^n A^n E_n R_n | \Omega} = \frac{1}{\Pr_\rho[\Omega]} \sum_{c^n \in \Omega} |c^n\rangle\langle c^n|_{C^n} \otimes \rho_{A^n E_n R_n, c^n}$$

for the state conditioned on Ω .

Theorem 4.3. Consider a sequence of channels $\mathcal{M}_i \in \text{CPTP}(R_{i-1}E_{i-1}, C_i A_i R_i E_i)$ for $i \in \{1, \dots, n\}$, where C_i are classical systems with common alphabet \mathcal{C} and the sequence $\{\mathcal{M}_i\}$ satisfies Equation (4.1) and the non-signalling condition: for each \mathcal{M}_i , there exists $\mathcal{R}_i \in \text{CPTP}(E_{i-1}, E_i)$ such that $\text{Tr}_{A_i R_i C_i} \circ \mathcal{M}_i =$

$\mathcal{R}_i \circ \text{Tr}_{R_{i-1}}$. Let $\varepsilon \in (0, 1)$, $\alpha \in (1, 3/2)$, $\Omega \subset \mathcal{C}^n$, $\rho_{R_0 E_0} \in \mathcal{S}(R_0 E_0)$, and f be an affine⁸ min-tradeoff function with $h = \min_{c^n \in \Omega} f(\text{freq}(c^n))$. Then,

$$H_{\min}^{\varepsilon}(A^n | E_n)_{\mathcal{M}_n \circ \dots \circ \mathcal{M}_1(\rho_{R_0 E_0}) | \Omega} \geq n h - n \frac{\alpha - 1}{2 - \alpha} \frac{\ln(2)}{2} V^2 - \frac{g(\varepsilon) + \alpha \log(1/\Pr_{\rho^n}[\Omega])}{\alpha - 1} - n \left(\frac{\alpha - 1}{2 - \alpha} \right)^2 K'(\alpha), \quad (4.3)$$

where $\Pr[\Omega]$ is the probability of observing event Ω , and

$$\begin{aligned} g(\varepsilon) &= -\log(1 - \sqrt{1 - \varepsilon^2}), \\ V &= \log(2d_A^2 + 1) + \sqrt{2 + \text{Var}(f)}, \\ K'(\alpha) &= \frac{(2 - \alpha)^3}{6(3 - 2\alpha)^3 \ln 2} 2^{\frac{\alpha-1}{2-\alpha}} (2 \log d_A + \text{Max}(f) - \text{Min}_{\Sigma}(f)) \ln^3 \left(2^{2 \log d_A + \text{Max}(f) - \text{Min}_{\Sigma}(f)} + e^2 \right), \end{aligned}$$

with $d_A = \max_i \dim(A_i)$.

Remark 4.4. The parameter in α in [Theorem 4.3](#) can be optimized for specific problems, which leads to tighter bounds. Alternatively, it is possible to make a generic choice for α to recover a theorem that looks much more like [Theorem 4.1](#), which is done in [Corollary 4.6](#). We also remark that even tighter second order terms have been derived in [\[LLR⁺21\]](#). To keep our theorem statement and proofs simpler, we do not carry out this additional optimization explicitly, but note that this can be done in complete analogy to [\[LLR⁺21\]](#).

To prove [Theorem 4.3](#), we will need the following lemma (which is already implicit in [\[DFR20, Claim 4.6\]](#), but we give a simplified proof here).

Lemma 4.5. Consider a quantum state $\rho \in \mathcal{S}(\text{CADE})$ that has the form

$$\rho_{\text{CADE}} = \sum_{c \in \Omega} |c\rangle\langle c| \otimes \rho_{AE,c} \otimes \rho_{D|c},$$

where $\Omega \subset \mathcal{C}$ is a subset of the alphabet \mathcal{C} of the classical system C , and for each c , $\rho_{AE,c} \in \text{Pos}(AE)$ is subnormalised and $\rho_{D|c} \in \mathcal{S}(D)$ is a quantum state. Then for $\alpha > 1$,

$$H_{\alpha}^{\dagger}(ACD|E)_{\rho} \leq H_{\alpha}^{\dagger}(AC|E)_{\rho} + \max_{c \in \Omega} H_{\alpha}(D)_{\rho_{D|c}}.$$

Proof. Let $\sigma_E \in \mathcal{S}(E)$ such that

$$H_{\alpha}^{\dagger}(ACD|E)_{\rho} = -D_{\alpha}(\rho_{\text{CADE}} \| \mathbb{1}_{\text{CAD}} \otimes \sigma_E).$$

Then

$$\left(\sigma_E^{\frac{1-\alpha}{2\alpha}} \rho_{\text{CADE}} \sigma_E^{\frac{1-\alpha}{2\alpha}} \right)^{\alpha} = \sum_{c \in \Omega} |c\rangle\langle c| \otimes \left(\sigma_E^{\frac{1-\alpha}{2\alpha}} \rho_{AE,c} \sigma_E^{\frac{1-\alpha}{2\alpha}} \right)^{\alpha} \otimes \rho_{D|c}^{\alpha}.$$

⁸A function f on the convex set $\mathbb{P}(\mathcal{C})$ is called *affine* if it is linear under convex combinations, i.e., for $\lambda \in [0, 1]$ and $p_1, p_2 \in \mathbb{P}(\mathcal{C})$, $\lambda f(p_1) + (1 - \lambda)f(p_2) = f(\lambda p_1 + (1 - \lambda)p_2)$. Such functions are also sometimes called *convex-linear*.

Hence,

$$\begin{aligned}
\mathrm{Tr} \left[\left(\sigma_E^{\frac{1-\alpha}{2\alpha}} \rho_{CADE} \sigma_E^{\frac{1-\alpha}{2\alpha}} \right)^\alpha \right] &= \sum_{c \in \Omega} \mathrm{Tr} \left[\left(\sigma_E^{\frac{1-\alpha}{2\alpha}} \rho_{AE,c} \sigma_E^{\frac{1-\alpha}{2\alpha}} \right)^\alpha \right] \mathrm{Tr} \left[\rho_{D|c}^\alpha \right] \\
&\leq \sup_{\tilde{\sigma}_E \in \mathcal{S}(E)} \mathrm{Tr} \left[\sum_{c \in \Omega} |c\rangle\langle c| \otimes \left(\tilde{\sigma}_E^{\frac{1-\alpha}{2\alpha}} \rho_{AE,c} \tilde{\sigma}_E^{\frac{1-\alpha}{2\alpha}} \right)^\alpha \right] \max_{c \in \Omega} \mathrm{Tr} \left[\rho_{D|c}^\alpha \right] \\
&= \sup_{\tilde{\sigma}_E \in \mathcal{S}(E)} \mathrm{Tr} \left[\left(\tilde{\sigma}_E^{\frac{1-\alpha}{2\alpha}} \rho_{CAE} \tilde{\sigma}_E^{\frac{1-\alpha}{2\alpha}} \right)^\alpha \right] \max_{c \in \Omega} \mathrm{Tr} \left[\rho_{D|c}^\alpha \right]
\end{aligned}$$

Recalling the definitions of D_α (Definition 2.1) and H_α^\dagger (Definition 2.2), we see that the lemma follows by taking the logarithm and multiplying by $\frac{1}{\alpha-1}$. \square

Proof of Theorem 4.3. As in the proof of Theorem 4.1, we first use [DFR20, Lemma B.10] to get

$$H_{\min}^\varepsilon(A^n | E_n)_{\mathcal{M}_n \circ \dots \circ \mathcal{M}_1(\rho_{R_0 E_0})|\Omega} \geq H_\alpha^\dagger(A^n | E_n)_{\mathcal{M}_n \circ \dots \circ \mathcal{M}_1(\rho_{R_0 E_0})|\Omega} - \frac{g(\varepsilon)}{\alpha-1} \quad (4.4)$$

for $\alpha \in (1, 2]$ and $g(\varepsilon) = \log(1 - \sqrt{1 - \varepsilon^2})$. We therefore need to find a lower bound for

$$H_\alpha^\dagger(A^n | E_n)_{\mathcal{M}_n \circ \dots \circ \mathcal{M}_1(\rho_{R_0 E_0})|\Omega} = H_\alpha^\dagger(A^n C^n | E_n)_{\mathcal{M}_n \circ \dots \circ \mathcal{M}_1(\rho_{R_0 E_0})|\Omega}, \quad (4.5)$$

where the equality holds because of Equation (4.1) and [DFR20, Lemma B.7].

Before proceeding with the formal proof, let us explain the main difficulty compared to Theorem 4.1. The state for which we need to compute the entropy in Equation (4.5) is conditioned on the event $\Omega \subset C^n$. This is a global event, in the sense that it depends on the classical outputs C_1, \dots, C_n of all rounds. We essentially seek a lower bound that involves $\min_{v \in \Sigma_i(\mathrm{freq}(c^n))} H_\alpha(A_i | E_i)_v$ for some $c^n \in \Omega$, i.e., for every round we only want to minimize over output states of the channel \mathcal{M}_i whose distribution on C_i matches the frequency distribution $\mathrm{freq}(c^n)$ of the n rounds we observed. This means that we must use the global conditioning on Ω to argue that in each round, we can restrict our attention to states whose outcome distribution matches the (worst-case) frequency distribution associated with Ω . The chain rule Theorem 3.1 does not directly allow us to do this as the r.h.s. of Equation (3.17) always minimizes over all possible input states.

To circumvent this, we follow a strategy that was introduced in [DFR20] and optimized in [DF19]. For every i , we introduce a quantum system D_i with $\dim(D_i) = \lceil 2^{\mathrm{Max}(f) - \mathrm{Min}(f)} \rceil$ and define $\mathcal{D}_i \in \mathrm{CPTP}(C_i, C_i D_i)$ by

$$\mathcal{D}_i(\omega_{C_i}) = \sum_{c \in \mathcal{C}} \langle c | \omega_{C_i} | c \rangle \cdot |c\rangle\langle c| \otimes \tau_{D_i|c}.$$

For every $c \in \mathcal{C}$, the state $\tau_{D_i|c} \in \mathcal{S}(D)$ is defined as the mixture between a uniform distribution on $\{1, \dots, \lceil 2^{\mathrm{Max}(f) - f(\delta_c)} \rceil\}$ and a uniform distribution on $\{1, \dots, \lceil 2^{\mathrm{Max}(f) - f(\delta_c)} \rceil\}$ that satisfies

$$H(D_i)_{\tau_{D_i|c}} = \mathrm{Max}(f) - f(\delta_c),$$

where δ_x stands for the distribution with all the weight on element x . This is clearly possible if $\dim(D_i) = \lceil 2^{\mathrm{Max}(f) - \mathrm{Min}(f)} \rceil$.

We define $\tilde{\mathcal{M}}_i = \mathcal{D}_i \circ \mathcal{M}_i$ and denote

$$\rho_{C^n A^n R_n E_n}^n = \mathcal{M}_n \circ \dots \circ \mathcal{M}_1(\rho_{R_0 E_0}) \quad \text{and} \quad \tilde{\rho}_{C^n A^n D^n R_n E_n}^n = \tilde{\mathcal{M}}_n \circ \dots \circ \tilde{\mathcal{M}}_1(\rho_{R_0 E_0}).$$

The state $\tilde{\rho}_{|\Omega}^n$ has the right form for us to apply [Lemma 4.5](#) and get

$$H_\alpha^\dagger(A^n C^n | E_n)_{\tilde{\rho}_{|\Omega}^n} \geq - \max_{c^n \in \Omega} H_\alpha(D^n)_{\tilde{\rho}_{D^n | c^n}^n} + H_\alpha^\dagger(A^n C^n D^n | E_n)_{\tilde{\rho}_{|\Omega}^n}, \quad (4.6)$$

where

$$\tilde{\rho}_{D^n | c^n}^n = \tau_{D_1 | c_1} \otimes \dots \otimes \tau_{D_n | c_n}.$$

We treat each term in [Equation \(4.6\)](#) in turn.

(i) For the term on the l.h.s., it is easy to see that $\tilde{\rho}_{C^n A^n R_n E_n | \Omega}^n = \rho_{C^n A^n R_n E_n | \Omega}^n$, so

$$H_\alpha^\dagger(A^n C^n | E_n)_{\tilde{\rho}_{|\Omega}^n} = H_\alpha^\dagger(A^n C^n | E_n)_{\rho_{|\Omega}^n}. \quad (4.7)$$

(ii) For the first term on the r.h.s., we compute

$$\begin{aligned} H_\alpha(D^n)_{\tilde{\rho}_{D^n | c^n}^n} &= \sum_i H_\alpha(D_i)_{\tau_{D_i | c_i}} \leq \sum_i H(D_i)_{\tau_{D_i | c_i}} = n \text{Max}(f) - \sum_i f(\delta_{c_i}) \\ &= n \text{Max}(f) - n f(\text{freq}(c^n)), \end{aligned} \quad (4.8)$$

where the last equality holds because f is affine.

(iii) For the second term on the r.h.s., we first use [[DFR20](#), Lemma B.5] to remove the conditioning on the event Ω , and then use that removing the classical system C^n and switching from H_α^\dagger to H_α can only decrease the entropy:

$$H_\alpha^\dagger(A^n C^n D^n | E_n)_{\tilde{\rho}_{|\Omega}^n} \geq H_\alpha(A^n D^n | E_n)_{\tilde{\rho}^n} - \frac{\alpha}{\alpha - 1} \log(1/\Pr_{\rho^n}[\Omega]),$$

where we used $\Pr_{\rho^n}[\Omega] = \Pr_{\tilde{\rho}^n}[\Omega]$. Now noting that $\text{Tr}_{D_i} \circ \tilde{\mathcal{M}}_i = \mathcal{M}_i$, we see that the non-signalling condition $\text{Tr}_{A_i R_i C_i} \circ \mathcal{M}_i = \mathcal{R}_i \circ \text{Tr}_{R_{i-1}}$ on \mathcal{M}_i implies the non-signalling condition $\text{Tr}_{A_i R_i C_i D_i} \circ \tilde{\mathcal{M}}_i = \mathcal{R}_i \circ \text{Tr}_{R_{i-1}}$ on $\tilde{\mathcal{M}}_i$. We can therefore apply the chain rule in [Lemma 3.6](#) to find

$$H_\alpha(A^n D^n | E_n)_{\tilde{\rho}^n} \geq \sum_{i=1}^n \min_{\omega_{i-1} \in \mathcal{S}(R_{i-1} E_{i-1} \tilde{E}_{i-1})} H_\beta(A_i D_i | E_i \tilde{E}_{i-1})_{\tilde{\mathcal{M}}_i(\omega_{i-1})},$$

where we introduced the shorthand $\beta := \frac{1}{2-\alpha}$ and the purifying system $\tilde{E}_{i-1} \equiv R_{i-1} E_{i-1}$. Noting that for $\alpha \in (1, 3/2)$ we have $\beta \in (1, 2)$, we can now use [[DF19](#), Corollary IV.2] to obtain

$$H_\beta(A_i D_i | E_i \tilde{E}_{i-1})_{\tilde{\mathcal{M}}_i(\omega_{i-1})} \geq H(A_i D_i | E_i \tilde{E}_{i-1})_{\tilde{\mathcal{M}}_i(\omega_{i-1})} - (\beta - 1) \frac{\ln(2)}{2} V^2 - (\beta - 1)^2 K(\beta),$$

where V^2 and $K(\beta)$ are quantities from [[DF19](#), Proposition V.3] that satisfy

$$\begin{aligned} K(\beta) &\leq \frac{1}{6(2-\beta)^3 \ln 2} 2^{(\beta-1)(2 \log d_A + \text{Max}(f) - \text{Min}_\Sigma(f))} \ln^3 \left(2^{2 \log d_A + \text{Max}(f) - \text{Min}_\Sigma(f)} + e^2 \right), \\ V^2 &= \left(\log(2d_A^2 + 1) + \sqrt{2 + \text{Var}(f)} \right)^2, \end{aligned}$$

where $d_A = \max_i \dim(A_i)$. Furthermore, as in the proof of [DF19, Proposition V.3], we have

$$H(A_i D_i | E_i \tilde{E}_{i-1})_{\mathcal{M}_i(\omega_{i-1})} \geq \text{Max}(f).$$

Therefore, the second term on the r.h.s. of Equation (4.6) is bounded by

$$\begin{aligned} & H_\alpha^\uparrow(A^n C^n D^n | E_n)_{\tilde{\rho}_\Omega^n} \\ & \geq n \text{Max}(f) - n(\beta - 1) \frac{\ln(2)}{2} V^2 - n(\beta - 1)^2 K(\beta) - \frac{\alpha}{\alpha - 1} \log(1/\text{Pr}_{\rho^n}[\Omega]). \end{aligned} \quad (4.9)$$

Combining our results for each of the three terms (i.e. Equation (4.7), Equation (4.8), and Equation (4.9)) and recalling $h = \min_{x^n \in \Omega} f(\text{freq}(x^n))$, Equation (4.6) becomes

$$H_\alpha^\uparrow(A^n C^n | E_n)_{\rho_\Omega^n} \geq n h - n(\beta - 1) \frac{\ln(2)}{2} V^2 - \frac{\alpha}{\alpha - 1} \log(1/\text{Pr}_{\rho^n}[\Omega]) - n(\beta - 1)^2 K(\beta).$$

Inserting this into Equation (4.4) and Equation (4.5), and defining $K'(\alpha) = K(\beta) = K(\frac{1}{2-\alpha})$ we obtain

$$\begin{aligned} & H_{\min}^\varepsilon(A^n | E_n)_{\mathcal{M}_n \circ \dots \circ \mathcal{M}_1(\rho_{R_0 E_0})|_\Omega} \\ & \geq n h - n(\beta - 1) \frac{\ln(2)}{2} V^2 - \frac{g(\varepsilon) + \alpha \log(1/\text{Pr}_{\rho^n}[\Omega])}{\alpha - 1} - n(\beta - 1)^2 K(\beta) \end{aligned} \quad (4.10)$$

as desired. \square

Corollary 4.6. *For the setting given in Theorem 4.3 we have*

$$H_{\min}^\varepsilon(A^n | E_n)_{\mathcal{M}_n \circ \dots \circ \mathcal{M}_1(\rho_{R_0 E_0})|_\Omega} \geq n h - c_1 \sqrt{n} - c_0,$$

where the constants c_1 and c_0 are given by

$$\begin{aligned} c_1 &= \sqrt{\frac{2 \ln(2) V^2}{\eta} \left(g(\varepsilon) + (2 - \eta) \log(1/\text{Pr}_{\rho^n}[\Omega]) \right)}, \\ c_0 &= \frac{(2 - \eta) \eta^2 \log(1/\text{Pr}_{\rho^n}[\Omega]) + \eta^2 g(\varepsilon)}{3(\ln 2)^2 V^2 (2\eta - 1)^3} 2^{\frac{1-\eta}{\eta} (2 \log d_A + \text{Max}(f) - \text{Min}_\Sigma(f))} \ln^3 \left(2^{2 \log d_A + \text{Max}(f) - \text{Min}_\Sigma(f)} + e^2 \right) \end{aligned}$$

with

$$\eta = \frac{2 \ln(2)}{1 + 2 \ln(2)}, \quad g(\varepsilon) = \log(1 - \sqrt{1 - \varepsilon^2}), \quad V = \log(2d_A^2 + 1) + \sqrt{2 + \text{Var}(f)}.$$

Proof. We first note that for any Ω with non-zero probability, $h \leq \log d_A$. Therefore, if $n \leq \left(\frac{c_1}{2 \log d_A} \right)^2$, it is easy to check that $n h - c_1 \sqrt{n} \leq -n \log d_A$, so the statement of Corollary 4.6 becomes trivial. We may therefore assume that $n \geq \left(\frac{c_1}{2 \log d_A} \right)^2$.

As in the proof of Theorem 4.3, we define $\beta = \frac{1}{2-\alpha}$. We will assume that $\alpha \in (1, 2 - \eta)$ for $\eta = \frac{2 \ln(2)}{1 + 2 \ln(2)} \approx 0.58$ and later make a choice of α that satisfies this condition. Then, $\beta - 1 = \frac{1}{2-\alpha} - 1 \leq \frac{\alpha-1}{\eta}$

and $\beta \in (1, 1/\eta)$. Therefore, using $K(\beta)$ as defined in the proof of [Theorem 4.3](#) and noting that in the interval $\beta \in (1, 1/\eta) \subset (1, 2)$ this quantity is monotonically increasing in β , we have

$$K(\beta) \leq K := \frac{\eta^3}{6(2\eta - 1)^3 \ln 2} 2^{\frac{1-\eta}{\eta}(2 \log d_A + \text{Max}(f) - \text{Min}_\Sigma(f))} \ln^3 \left(2^{2 \log d_A + \text{Max}(f) - \text{Min}_\Sigma(f)} + e^2 \right),$$

Hence, we can simplify the statement of [Theorem 4.3](#) to

$$\begin{aligned} & H_{\min}^\varepsilon(A^n | E_n)_{\mathcal{M}_n \circ \dots \circ \mathcal{M}_1(\rho_{R_0 E_0}) | \Omega} \\ & \geq n h - n(\alpha - 1) \frac{\ln(2)}{2\eta} V^2 - \frac{g(\varepsilon) + (2 - \eta) \cdot \log(1/\Pr_{\rho^n}[\Omega])}{\alpha - 1} - n(\alpha - 1)^2 \frac{K}{\eta^2}. \end{aligned} \quad (4.11)$$

We now choose $\alpha > 1$ as a function of n and ε so that the terms proportional to $\alpha - 1$ and $\frac{1}{\alpha - 1}$ match:

$$\alpha = 1 + \sqrt{\frac{2\eta}{n \ln(2) V^2} \left(g(\varepsilon) + (2 - \eta) \log(1/\Pr_{\rho^n}[\Omega]) \right)}.$$

Inserting this choice of α into [Equation \(4.11\)](#) and combining terms yields the constants in [Corollary 4.6](#). The final step is to show that this choice of α indeed satisfies $\alpha \leq 2 - \eta$ for $n \geq (\frac{c_1}{2 \log d_A})^2$. For this, we note that for $n \geq (\frac{c_1}{2 \log d_A})^2$

$$\alpha = 1 + \frac{\eta}{\ln(2) V^2} \frac{c_1}{\sqrt{n}} \leq 1 + \frac{2\eta \log d_A}{\ln(2) V^2}.$$

We can now use that $V^2 \geq (\log(2d_A^2))^2 \geq 4 \log d_A$ since $d_A \geq 2$, so

$$\alpha \leq 1 + \frac{2\eta \log d_A}{\ln(2) V^2} \leq 1 + \frac{\eta}{2 \ln(2)} = 2 - \eta,$$

where the last inequality holds because $\eta = \frac{2 \ln(2)}{1 + 2 \ln(2)}$. □

In many applications, e.g. randomness expansion or QKD, a round can either be a “data generation round” (e.g. to generate bits of randomness or key) or a “test round” (e.g. to test whether a device used in the protocol behaves as intended). More formally, in this case the maps $\mathcal{M}_i \in \text{CPTP}(R_{i-1} E_{i-1}, C_i A_i R_i E_i)$ can be written as

$$\mathcal{M}_i = \gamma \mathcal{M}_{i, R_{i-1} E_{i-1} \rightarrow C_i A_i R_i E_i}^{\text{test}} + (1 - \gamma) \mathcal{M}_{i, R_{i-1} E_{i-1} \rightarrow A_i R_i E_i}^{\text{data}} \otimes |\perp\rangle\langle\perp|_{C_i}, \quad (4.12)$$

where the output of $\mathcal{M}_i^{\text{test}}$ on system C_i is from some alphabet \mathcal{C}' that does not include \perp , so the alphabet of system C_i is $\mathcal{C} = \mathcal{C}' \cup \{\perp\}$. The parameter γ is called the *testing probability*, and for efficient protocols we usually want γ to be as small as possible.

For maps of the form in [Equation \(4.12\)](#), there is a general way of constructing a min-tradeoff function for the map \mathcal{M}_i based only on the statistics generated by the map $\mathcal{M}_i^{\text{test}}$. This was shown in [\[DF19\]](#) and we reproduce their result (adapted to our notation) here for the reader’s convenience.

Lemma 4.7 ([DF19, Lemma V.5]). *Let $\mathcal{M}_i \in \text{CPTP}(R_{i-1}E_{i-1}, C_iA_iR_iE_i)$ be channels satisfying the same conditions as in [Theorem 4.3](#) that can furthermore be decomposed as in [Equation \(4.12\)](#). Suppose that an affine function $g : \mathbb{P}(C') \rightarrow \mathbb{R}$ satisfies for any $q \in \mathbb{P}(C')$ and any $i = 1, \dots, n$*

$$g(q') \leq \min_{\omega \in \mathcal{S}(R_{i-1}E_{i-1}\tilde{E}_{i-1})} \{H(A_i|E_i\tilde{E}_{i-1})_{\mathcal{M}_i(\omega)} : (\mathcal{M}_i^{\text{test}}(\omega))_{C_i} = q'\} \quad (4.13)$$

where $\tilde{E}_{i-1} \equiv R_{i-1}E_{i-1}$ is a purifying system. Then, the affine function $f : \mathbb{P}(C) \rightarrow \mathbb{R}$ defined by

$$\begin{aligned} f(\delta_x) &= \text{Max}(g) + \frac{1}{\gamma}(g(\delta_x) - \text{Max}(g)) \quad \forall x \in C' \\ f(\delta_\perp) &= \text{Max}(g) \end{aligned}$$

is a min-tradeoff function for $\{\mathcal{M}_i\}$. Moreover,

$$\begin{aligned} \text{Max}(f) &= \text{Max}(g) \\ \text{Min}(f) &= \left(1 - \frac{1}{\gamma}\right) \text{Max}(g) + \frac{1}{\gamma} \text{Min}(g) \\ \text{Min}_\Sigma(f) &\geq \text{Min}(g) \\ \text{Var}(f) &\leq \frac{1}{\gamma} (\text{Max}(g) - \text{Min}(g))^2. \end{aligned}$$

5 Sample applications

To demonstrate the utility of our generalised EAT, we provide two sample applications. Firstly, in [Section 5.1](#) we prove security of blind randomness expansion against general attacks. The notion of blind randomness was defined in [MS17] and has potential applications in mistrustful cryptography (see [MS17, FM18] for a detailed motivation). Until now, no security proof against general attacks was known. In particular, the original EAT is not applicable because its model of side information is too restrictive. With our generalised EAT, we can show that security against general attacks follows straightforwardly from a single-round security statement.

Secondly, in [Section 5.2](#) we give a simplified security proof for the E91 QKD protocol [Eke91], which was also treated with the original EAT [DFR20]. This example is meant to help those familiar with the original EAT understand the difference between that result and our generalised EAT. In particular, this application highlights the utility of our more general model of side information: in our proof, the non-signalling condition is satisfied trivially and the advantage over the original EAT stems purely from being able to update the side information register E_i . We point out that while here we focus on the E91 protocol to allow an easy comparison with the original EAT, our generalised EAT can be used for a large class of QKD protocols for which the original EAT was not applicable at all. A comprehensive treatment of this is given in [MR22].

5.1 Blind randomness expansion

We start by recalling the idea of standard (non-blind) device-independent randomness expansion [Col06, CK11, PAM⁺10, VV12, MS16]. Alice would like to generate a uniformly random bit string using devices D_1 and D_2 prepared by an adversary Eve. To this end, in her local lab (which Eve cannot access) she isolates

the devices from one another and plays multiple round of a non-local game with them, e.g. the CHSH game. On a subset of the rounds of the game, she checks whether the CHSH condition is satisfied. If this is the case on a sufficiently high proportion of rounds, she can conclude that the devices' outputs on the remaining rounds must contain a certain amount of entropy, conditioned on the input to the devices and any quantum side information that Eve might have kept from preparing the devices. Using a quantum-proof randomness extractor, Alice can then produce a uniformly random string.

Blind randomness expansion [MS17, FM18] is a significant strengthening of the above idea. Here, Alice only receives one device D_1 , which she again places in her local lab isolated from the outside world. Now, Alice plays a non-local game with her device D_1 and the adversary Eve: she samples questions for a non-local game as before, inputs one of the questions to D_1 , and sends the other question to Eve. D_1 and Eve both provide an output. Alice then proceeds as in standard randomness expansion, checking whether the winning condition of the non-local game is satisfied on a subset of rounds and concluding that the output of her device D_1 must contain a certain amount of entropy conditioned on the adversary's side information.

For the purpose of applying the EAT, the crucial difference between the two notions of randomness expansion is the following: in standard randomness expansion, the adversary's quantum side information is not acted upon during the protocol, and additional side information (the inputs to the devices, which we also condition on) are generated independently in a round-by-round manner. This allows a relatively straightforward application of the standard EAT [AFDF⁺18]. In contrast, in blind randomness expansion, the adversary's quantum side information gets updated in every round of the protocol and is not generated independently in a round-by-round fashion. This does not fit in the framework of the standard EAT, which requires the side information to be generated round-by-round subject to a Markov condition. As a result, [MS17, FM18] were not able to prove a general multi-round blind randomness expansion result.

In the rest of this section, we will show that our generalised EAT is capable of treating multi-round blind randomness expansion, using a protocol similar to [AFRV19, Protocol 3.1]. A formal description of the protocol is given in Protocol 1.

The following proposition shows a lower bound on the amount of randomness Alice can extract from this protocol, as specified by the min-entropy. For this, we assume a lower-bound on the single-round von Neumann entropy. Such a single-round bound can be found numerically using a generic method as explained after the proof Proposition 5.1.

Proposition 5.1. *Suppose Alice executes Protocol 1 with a device D that cannot communicate with Eve. We denote by R_i and E'_i the (arbitrary) quantum systems of the device D and the adversary Eve after the i -th round, respectively. Eve's full side-information after the i -th round is $E_i := T^i X^i Y^i B^i E'_i$. A single round of the protocol can be described by a quantum channel $\mathcal{N}_i \in \text{CPTP}(R_{i-1} \tilde{E}_{i-1}, C_i A_i R_i E_i)$. We also define $\mathcal{N}_i^{\text{test}}$ to be the same as \mathcal{N}_i , except that $\mathcal{N}_i^{\text{test}}$ always picks $T_i = 1$. Let $\rho_{A^n C^n R_n E_n}$ be the state at the end of the protocol and Ω the event that Alice does not abort.*

Let $g : \mathbb{P}(\{0, 1\}) \rightarrow \mathbb{R}$ be an affine function satisfying the conditions

$$g(p) \leq \inf_{\omega \in \mathcal{S}(R_{i-1} E_{i-1} \tilde{E}_{i-1}) : \mathcal{N}_i^{\text{test}}(\omega)_{C_i} = p} H(A_i | E_i \tilde{E}_{i-1})_{\mathcal{N}_i(\omega)}, \quad \text{Max}(g) = g(\delta_1), \quad (5.1)$$

where $\tilde{E}_{i-1} \equiv R_{i-1} E_{i-1}$ is a purifying system. Then, for any $\varepsilon_a, \varepsilon_s \in (0, 1)$, either $\Pr[\Omega] \leq \varepsilon_a$ or

$$H_{\min}^{\varepsilon_s}(A^n | E_n) \geq nh - c_1 \sqrt{n} - c_0$$

for $c_1, c_0 \geq 0$ independent of n and

$$h = \min_{p' \in \mathbb{P}(\{0, 1\}) : p'(0) \leq 1 - \omega_{\text{exp}} + \delta} g(p'),$$

Protocol 1. General blind randomness expansion protocol

Protocol arguments

- G : two-player non-local game, specified by a question set $\mathcal{X} \times \mathcal{Y}$, a probability distribution q on $\mathcal{X} \times \mathcal{Y}$, an answer set $\mathcal{A} \times \mathcal{B}$, and a winning condition $\omega : \mathcal{X} \times \mathcal{Y} \times \mathcal{A} \times \mathcal{B} \rightarrow \{0, 1\}$
- $x^* \in \mathcal{X}, y^* \in \mathcal{Y}$: inputs used for generation rounds
- D : untrusted device capable of playing one side of G repeatedly
- $n \in \mathbb{N}$: number of rounds
- $\gamma \in (0, 1]$: expected fraction of test rounds
- ω_{exp} : expected winning probability in G
- δ : error tolerance

Protocol steps

For rounds $i = 1, \dots, n$, Alice performs the following steps:

- (1) Alice chooses $T_i \in \{0, 1\}$ with $\Pr[T_i = 1] = \gamma$. If $T_i = 1$, Alice chooses $X_i, Y_i \in \mathcal{X} \times \mathcal{Y}$ according to the question distribution q . If $T_i = 0$, Alice chooses $X_i = x^*, Y_i = y^*$.
- (2) Alice inputs X_i into her device D and sends Y_i to Eve. She receives answers A_i and B_i , respectively.
- (3) If $T_i = 0$, Alice sets $C_i = \perp$. If $T_i = 1$, Alice sets $C_i = \omega(X_i, Y_i, A_i, B_i)$.

At the end of the protocol, Alice aborts if $|\{i \text{ s.t. } C_i = 0\}| > (1 - \omega_{\text{exp}} + \delta) \cdot \gamma n$.

where ω_{exp} is the expected winning probability and δ the error tolerance from [Protocol 1](#). If we treat $\varepsilon_s, \varepsilon_a, \dim(A_i), \delta, \text{Max}(g)$, and $\text{Min}(g)$ as constants, then $c_1 = O(1/\sqrt{\gamma})$ and $c_0 = O(1)$.

Furthermore, if there exists a quantum strategy that wins the game G with probability ω_{exp} , there is an honest behaviour of D and Eve for which $\Pr[\Omega] \geq 1 - \exp(-\frac{\delta^2}{1-\omega_{\text{exp}}+\delta}\gamma n)$.

Remark 5.2. The condition on $g(p)$ in [Equation \(5.1\)](#) is formulated in terms of the entropy

$$H(A_i | E_i \tilde{E}_{i-1})_{\mathcal{N}_i(\omega)} = H(A_i | T^i X^i Y^i B^i E'_i \tilde{E}_{i-1})_{\mathcal{N}_i(\omega)}$$

with $\tilde{E}_{i-1} \equiv R_{i-1} E_{i-1}$. However, the map \mathcal{N}_i corresponding to the i -th round does not act on the systems $T^{i-1} X^{i-1} Y^{i-1} B^{i-1}$. Therefore, we can view these systems as part of the purifying system. Since the infimum in [Equation \(5.1\)](#) already includes a purifying \tilde{E}_{i-1} , we can drop these additional systems and without loss of generality choose \tilde{E}_{i-1} to be isomorphic to those input systems on which \mathcal{N}_i acts non-trivially, i.e. $\tilde{E}_{i-1} \equiv R_{i-1} E'_{i-1}$. This means that we can replace the upper bound on g in [Equation \(5.1\)](#) by the equivalent condition

$$g(p) \leq \inf_{\omega \in \mathcal{S}(R_{i-1} E_{i-1} \tilde{E}_{i-1}) : \mathcal{N}_i^{\text{test}}(\omega)_{C_i} = p} H(A_i | B_i X_i Y_i T_i E'_i \tilde{E}_{i-1})_{\mathcal{N}_i(\omega)} \quad (5.2)$$

with $\tilde{E}_{i-1} \equiv R_{i-1} E'_{i-1}$. For the proof of [Proposition 5.1](#) we will use [Equation \(5.1\)](#) since it more closely matches the notation of [Theorem 4.3](#), but intuitively, [Equation \(5.2\)](#) is more natural as it only involves quantities related to the i -th round of the protocol.

Proof of Proposition 5.1. To show the min-entropy lower bound, we will make use of [Corollary 4.6](#). For this, we first check that the maps \mathcal{N}_i satisfy the required conditions. Since C_i is a deterministic function of the (classical) variables $X_i, Y_i, A_i,$ and B_i , it is clear that [Equation \(4.1\)](#) is satisfied. For the non-signalling condition, we define the map $\mathcal{R}_i \in \text{CPTP}(E_{i-1}, E_i)$ as follows: \mathcal{R}_i samples T_i, X_i and Y_i as Alice does in [Step \(1\)](#) of [Protocol 1](#). \mathcal{R} then performs Eve's actions in the protocol (which only act on Y_i and E'_{i-1} , which is part of E_{i-1}). It is clear that the distribution on X_i and Y_i produced by \mathcal{R}_i is the same as for \mathcal{N}_i . By the assumption that D and Eve cannot communicate, the marginal of the output of \mathcal{N}_i on Eve's side must be independent of the device's system R_{i-1} . Hence, $\text{Tr}_{A_i R_i C_i} \circ \mathcal{N}_i = \mathcal{R}_i \circ \text{Tr}_{R_{i-1}}$.

To construct a min-tradeoff function, we note that we can split $\mathcal{N}_i = \gamma \mathcal{N}_i^{\text{test}} + (1 - \gamma) \mathcal{N}_i^{\text{data}}$, with $\mathcal{N}_i^{\text{test}}$ always picking $T_i = 1$ and $\mathcal{N}_i^{\text{data}}$ always picking $T_i = 1$. Then, we get from [Lemma 4.7](#) and the condition $\text{Max}(g) = g(\delta_1)$ that the affine function f defined by

$$f(\delta_0) = g(\delta_1) + \frac{1}{\gamma}(g(\delta_0) - g(\delta_1)), \quad f(\delta_1) = f(\delta_\perp) = g(\delta_1)$$

is an affine min-tradeoff function for $\{\mathcal{N}_i\}$.

Viewing the event Ω as a subset of the range $\{0, 1\}^n$ of the random variable C^n and comparing with the abort condition in [Protocol 1](#), we see that $c^n \in \Omega$ implies $\text{freq}(c^n)(0) \leq (1 - \omega_{\text{exp}} + \delta)\gamma$. Therefore, for $c^n \in \Omega$ and denoting $p = \text{freq}(c^n)$,

$$f(\text{freq}(c^n)) = p(0)f(\delta_0) + (1 - p(0))g(\delta_1) = \frac{p(0)}{\gamma}p(0) + \left(1 - \frac{p(0)}{\gamma}\right)g(\delta_1) \geq h,$$

where the last inequality holds because g is affine and the distribution $p'(0) = p(0)/\gamma, p'(1) = 1 - p(0)/\gamma$ satisfies $p'(0) \leq 1 - \omega_{\text{exp}} + \delta$. The proposition now follows directly from [Corollary 4.6](#) and the scaling of c_1 and c_0 is easily obtained from the expressions in [Corollary 4.6](#).

To show that an honest strategy succeeds in the protocol with high probability, we define a random variable F_i by $F_i = 1$ if $C_i = 0$, and $F_i = 0$ otherwise. If D and Eve execute execute the quantum strategy that wins the game G with probability ω_{exp} in each round, then $\mathbb{E}[F_i] = (1 - \omega_{\text{exp}})\gamma$. Using the abort condition in the protocol, we then find

$$\begin{aligned} \Pr[\text{abort}] &= \Pr\left[\sum_{i=1}^n F_i > (1 - \omega_{\text{exp}} + \delta) \cdot \gamma n\right] \\ &= \Pr\left[\sum_{i=1}^n F_i > \left(1 + \frac{\delta}{1 - \omega_{\text{exp}}}\right) \cdot \mathbb{E}\left[\sum_{i=1}^n F_i\right]\right] \\ &\leq e^{-\frac{\delta^2}{1 - \omega_{\text{exp}} + \delta} \gamma n}, \end{aligned}$$

where in the last line we used a Chernoff bound. □

To make use of [Proposition 5.1](#), we need to construct a function $g(p)$ that satisfies the condition in [Equation \(5.1\)](#). For this, we will use the equivalent condition [Equation \(5.2\)](#). A general way of obtaining such

a bound automatically is using the recent numerical method [BFF21].⁹ Specifically, using the assumption that Alice’s lab is isolated, the maps \mathcal{N}_i describing a single round of the protocol take the form described in Figure 1.

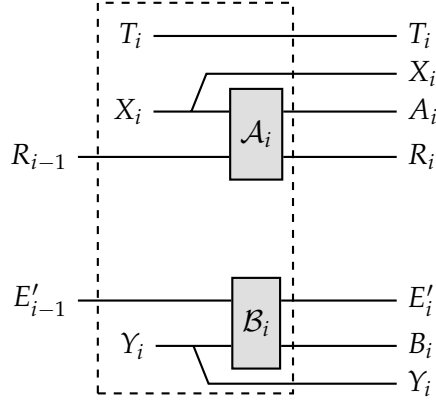

Figure 1: Circuit diagram of $\mathcal{N} : R_{i-1}E'_{i-1} \rightarrow A_iR_iT_iX_iY_iB_iE'_i$. For every round of the protocol, a circuit of this form is applied, where \mathcal{A} and \mathcal{B} are the (arbitrary) channels applied by Alice’s device and Eve, respectively. As in the protocol, T_i is a bit equal to 1 with probability γ , and X_i and Y_i are generated according to q whenever $T_i = 1$, and are fixed to x^*, y^* otherwise. We did not include the register C_i in the figure as it is a deterministic function of $T_iX_iY_iA_iB_i$.

The method of [BFF21] allows one to obtain lower bounds on the infimum of

$$H(A_i|B_iX_iY_iT_iE'_i\tilde{E}_{i-1})_{\mathcal{N}_i(\omega_{R_{i-1}E'_{i-1}\tilde{E}_{i-1}})}$$

over all input states $\omega_{R_{i-1}E'_{i-1}\tilde{E}_{i-1}}$ and for any map \mathcal{N}_i of the form depicted in Figure 1. Importantly, for any \mathcal{N}_i we may also restrict the infimum to states ω that are consistent with the observed statistics, i.e., $\mathcal{N}^{\text{test}}(\omega)_{C_i} = p$ for some distribution p on C_i , using the notation of Proposition 5.1. Using this numerical method for the CHSH game, we obtain the values shown in Figure 2. From this, one can also construct an explicit affine min-tradeoff function $g(p)$ in an automatic way using the same method as in [BRC19]. As our focus is on illustrating the use of the generalised EAT, not the single-round bound, we do not carry out these steps in detail here.

Combining this single-round bound and Proposition 5.1, one obtains that for Protocol 1 instantiated with the CHSH game, ω_{exp} sufficiently close to the maximal winning probability of $\frac{1}{2} + \frac{1}{2\sqrt{2}}$, and $\gamma = \Theta(\frac{\log n}{n})$, one can extract $\Omega(n)$ bits of uniform randomness from $A_1 \dots A_n$ while using only $\text{polylog}(n)$ bits of randomness to run the protocol. In other words, Protocol 1 achieves exponential blind randomness expansion with the CHSH game.

⁹The main result of [MS17] (Theorem 14) does not appear to be sufficient for this. The reason is that the statement made in [MS17] essentially concerns the randomness produced on average over the question distribution q of the game G . However, choosing a question at random consumes randomness, so to achieve exponential randomness expansion, in Protocol 1 we fix the inputs x^*, y^* used for generation rounds. To the best of our knowledge, the results of [MS17] do not give a bound on the randomness produced in the non-local game for any fixed inputs x^*, y^* . If one could prove an analogous statement to [MS17, Theorem 14] that also certifies randomness on fixed inputs for a large class of games, our Proposition 5.1 would then imply exponential blind randomness expansion for any such game. Alternatively, one can also assume that public (non-blind) randomness is a free resource and use this to choose the inputs for the non-local game. Then, no special inputs x^*, y^* are needed in Protocol 1 to “save randomness” and the result of [MS17] combined with our generalised EAT implies that such a conversion from public to blind randomness is possible for any complete-support game.

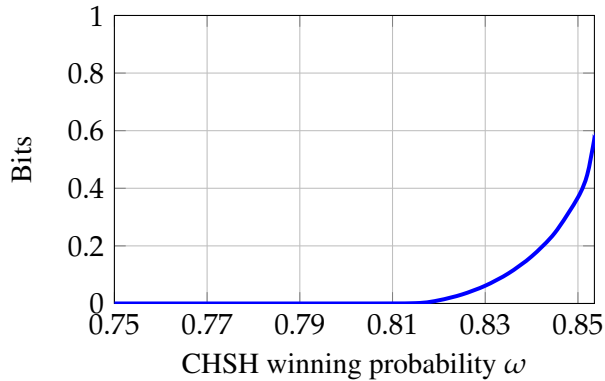

Figure 2: Lower bound on the conditional entropy $H(A_i|B_iX_iY_iT_iE'_i)_{\rho_{T_i=0}}$ for any state generated as in [Figure 1](#) and such that on test rounds the obtained winning probability for the CHSH game is ω . This lower bound was obtained by using the method from [\[BFF21\]](#). For each input $y \in \mathcal{Y}$, the channel \mathcal{B}_y is modelled as $\mathcal{B}_y(\omega) = \sum_b \Pi_y^{(b)} \omega \Pi_y^{(b)}$, where $\{\Pi_y^{(b)}\}_{b \in \mathcal{B}}$ are orthogonal projectors summing to the identity, and similarly for the map \mathcal{A} . It is simple to see that this is without loss of generality.

5.2 E91 quantum key distribution protocol

The E91 protocol is one of the simplest entanglement-based QKD protocols [\[Eke91\]](#). This protocol was already treated using the original EAT in [\[DFR20\]](#). Here, we do not give a formal security definition and proof, only an informal comparison of how the original EAT and our generalised EAT can be applied to this problem; the remainder of the security proof is then exactly as in [\[DFR20\]](#). For a detailed treatment of the application of our generalised EAT to QKD, see [\[MR22\]](#). To facilitate the comparison with [\[DFR20\]](#), in this section we label systems the same as in [\[DFR20\]](#) even though this differs from the system labels used earlier in this paper. The protocol we are considering is described explicitly in [Protocol 2](#). It is the same as in [\[DFR20\]](#) except for minor modifications to simplify the notation.

We consider the systems $B_i, \bar{B}_i, A_i, \bar{A}_i, Q_i, \bar{Q}_i$ as in [Protocol 2](#) and additionally define the system X_i storing the statistical information used in the parameter estimation step:

$$X_i = \begin{cases} A_i \oplus \bar{A}_i & \text{if } B_i = \bar{B}_i = 1, \\ \perp & \text{otherwise.} \end{cases}$$

Denoting by E the side information gathered by Eve during the distribution step, we can follow the same steps as for [\[DFR20, Equation \(57\)\]](#) to show that the security of [Protocol 2](#) follows from a lower bound on

$$H_{\min}^\epsilon(A^n | B^n \bar{B}^n E)_{\rho_{|\Omega}}. \tag{5.3}$$

Here, $\rho_{|\Omega}$ is the state at the end of the protocol conditioned on acceptance.

We first sketch how the original EAT (whose setup was described in [Section 1](#)) is applied to this problem in [\[DFR20\]](#). One cannot bound $H_{\min}^\epsilon(A^n | B^n \bar{B}^n E)_{\rho_{|\Omega}}$ directly using the EAT because a condition similar to [Equation \(4.1\)](#) has to be satisfied. Therefore, one modifies the systems \bar{A}_i from [Protocol 2](#) by setting $\bar{A}_i = \perp$ if $B_i = \bar{B}_i = 0$ and then applies the EAT to find a lower bound on

$$H_{\min}^\epsilon(A^n \bar{A}^n | B^n \bar{B}^n E)_{\rho_{|\Omega}}. \tag{5.4}$$

Protocol 2. E91 quantum key distribution protocol

Protocol arguments

- $n \in \mathbb{N}$: number of uses of qubit channel
- $\mu \in (0, 1)$: probability for measurements in diagonal basis
- $e \in (0, \frac{1}{2})$: maximum tolerated phase error ratio
- $\vartheta_{\text{EC}} \in [0, 1]$: relative communication cost of error correction scheme EC
- $r \in [0, 1]$: key rate

Protocol steps

- (1) *Distribution:* For $i \in \{1, \dots, n\}$, Alice prepares a pair (Q_i, \bar{Q}_i) of entangled qubits and sends \bar{Q}_i to Bob. Alice generates a random bit B_i such that $P_{B_i}(1) = \mu$ and, depending on whether $B_i = 0$ or $B_i = 1$, measures Q_i in either the computational or the diagonal basis, storing the outcome as A_i . In the same way, Bob measures \bar{Q}_i in a basis determined by a random bit \bar{B}_i , storing the outcome as \bar{A}_i .
- (2) *Sifting and information reconciliation:* Alice and Bob announce B_i and \bar{B}_i . On indices i where $B_i \neq \bar{B}_i$, they set $A_i = \bar{A}_i = \perp$. They invoke a reliable¹⁰ error correction scheme EC, allowing Bob to compute a guess \hat{A}^n for Alice's string A^n . If EC does not output a guess then the protocol is aborted.
- (3) *Parameter estimation:* Bob counts the number of indices $i \in S$ for which $\bar{B}_i = 1$ and $\bar{A}_i \neq \hat{A}_i$. If this number is larger than $e\mu^2 n$ then the protocol is aborted.
- (4) *Privacy amplification:* see [DFR20] for details.

For this, a round of Protocol 2 is viewed as a map $\mathcal{M}_i : Q_i^n \bar{Q}_i^n \rightarrow Q_{i+1}^n \bar{Q}_{i+1}^n A_i \bar{A}_i B_i \bar{B}_i X_i$, which chooses $B_i \bar{B}_i$ as in Protocol 2, applies Alice and Bob's (trusted) measurements on systems $Q_i \bar{Q}_i$ to generate $A_i \bar{A}_i$, and generates X_i as described before. To apply the EAT, $R_{i-1} := Q_i^n \bar{Q}_i^n$ takes the role of the "hidden system", and $A_i \bar{A}_i$ and $B_i \bar{B}_i$ are the output and side information of the i -th round, respectively. It is easy to see that with this choice of systems, the Markov condition of the EAT is satisfied, so, using a min-tradeoff function derived from an entropic uncertainty relation [BCC⁺10], one can find a lower bound on Equation (5.4).

However, adding the system \bar{A}_i in this manner has the following disadvantage: to relate the lower bound on $H_{\min}^\epsilon(A^n \bar{A}^n | B^n \bar{B}^n E)_{\rho_{|\Omega}}$ to the desired lower bound on $H_{\min}^\epsilon(A^n | B^n \bar{B}^n E)_{\rho_{|\Omega}}$ one needs to use a chain rule for min-entropies, incurring a penalty term of the form $H_{\max}^\epsilon(\bar{A}^n | A^n B^n \bar{B}^n E)_{\rho_{|\Omega}}$. This penalty term is relatively easy to bound for the case of the E91 protocol, but can cause problems in general.

We now turn our attention to proving Equation (5.3) using our generalised EAT. For this, we first observe that

$$H_{\min}^\epsilon(A^n | B^n \bar{B}^n E)_{\rho_{|\Omega}} \geq H_{\min}^\epsilon(A^n | B^n \bar{B}^n X^n E)_{\rho_{|\Omega}},$$

so it suffices to find a lower bound on the r.h.s. This step is similar to adding the \bar{A}_i systems in Equation (5.4) in that its purpose is to satisfy Equation (4.1). However, it has the advantage that here, X^n can be added to the conditioning system and therefore lowers the entropy, not raises it like going from Equation (5.3)

to Equation (5.4). The same step is not possible in the original EAT due to the restrictive Markov condition.

Using the same system names as before, we define $E_i := Q_{i+1}^n \bar{Q}_{i+1}^n B^i \bar{B}^i X^i E$.¹¹ Then, analogously to the original EAT, we can describe a single round of Protocol 2 by a map $\mathcal{M}_i : E_{i-1} \rightarrow A_i E_i X_i$. (Compared to the map \mathcal{M}_i we described above for the original EAT, we have traced out \bar{A}_i , added a copy of X_i , and added identity maps on the other additional systems in E_{i-1} .) Denoting by $\rho_{Q^n \bar{Q}^n E}^0$ the joint state of Alice and Bob’s systems $Q^n \bar{Q}^n$ before measurement and the information E that Eve gathered during the distribution step, the state at the end of the protocol is $\rho = \mathcal{M}_n \circ \dots \circ \mathcal{M}_1(\rho^0)$. To apply Corollary 4.6 to find a lower bound on

$$H_{\min}^\varepsilon(A^n | E_n)_{\mathcal{M}_n \circ \dots \circ \mathcal{M}_1(\rho^0)_{|\Omega}},$$

we first observe that the condition in Equation (4.1) is satisfied because the system X^n is part of E_n , and the non-signalling condition is trivially satisfied because there is no R_i -system. A min-tradeoff function can be constructed in exactly the same way as in [DFR20, Claim 5.2] by noting that all systems in E_i on which \mathcal{M}_i does not act can be viewed as part of the purifying system.

This comparison highlights the advantage of the more general model of side information in our generalised EAT: for the original EAT, one has to add the systems \bar{A}_i to the “non-conditioning side” of the min-entropy in order to be able to satisfy the Markov condition. In our case, the non-signalling condition, the analogue of the Markov condition, is trivially satisfied because we need no R_i -system. This is because we can add the quantum systems $Q^n \bar{Q}^n$ to the side information register E_0 at the start and then, since we allow side information to be updated and Alice and Bob act on $Q_i \bar{Q}_i$ using trusted measurement devices, we can remove the systems $Q_i \bar{Q}_i$ one by one during the rounds of the protocol.

Acknowledgements We thank Rotem Arnon-Friedman, Peter Brown, Kun Fang, Raban Iten, Joseph M. Renes, Ernest Tan, Jinzhao Wang, John Wright, and Yuxiang Yang for helpful discussions. We further thank Mario Berta and Marco Tomamichel for insights on Lemma 3.2, and Frédéric Dupuis and Carl Miller for discussions about blind randomness expansion. Part of this work was carried out when DS was with the Institute for Theoretical Physics at ETH Zurich. TM and RR acknowledge support from the National Centres of Competence in Research (NCCRs) QSIT (funded by the Swiss National Science Foundation under grant number 51NF40-185902) and SwissMAP, the Air Force Office of Scientific Research (AFOSR) via project No. FA9550-19-1-0202, the SNSF project No. 200021_188541 and the QuantERA project eDICT. OF acknowledges funding from the European Research Council (ERC Grant Agreement No. 851716).

References

- [AFDF⁺18] Rotem Arnon-Friedman, Frédéric Dupuis, Omar Fawzi, Renato Renner, and Thomas Vidick. Practical device-independent quantum cryptography via entropy accumulation. *Nature communications*, 9(1):459, 2018.
- [AFRV19] Rotem Arnon-Friedman, Renato Renner, and Thomas Vidick. Simple and tight device-independent security proofs. *SIAM Journal on Computing*, 48(1):181–225, 2019.

¹¹In Protocol 2, instead of Alice distributing the systems $Q_i \bar{Q}_i$ and Eve gathering side information E by intercepting \bar{Q}_i , we can equivalently imagine that Eve first prepares a state $\rho_{Q^n \bar{Q}^n E}^0$ and distributes $Q_i \bar{Q}_i$ to Alice and Bob in each round. Then, the choice of E_i intuitively captures the side information available to Eve from the first i rounds: Eve still possess the systems $Q_{i+1}^n \bar{Q}_{i+1}^n$ to be distributed in future rounds, has gathered classical information $B^i \bar{B}^i X^i$, and keeps the static side information E from preparing the initial state.

- [BCC⁺10] Mario Berta, Matthias Christandl, Roger Colbeck, Joseph M Renes, and Renato Renner. The uncertainty principle in the presence of quantum memory. *Nature Physics*, 6(9):659–662, 2010.
- [BFF21] Peter Brown, Hamza Fawzi, and Omar Fawzi. Device-independent lower bounds on the conditional von Neumann entropy. *arXiv preprint arXiv:2106.13692*, 2021.
- [BMP18] Cédric Bamps, Serge Massar, and Stefano Pironio. Device-independent randomness generation with sublinear shared quantum resources. *Quantum*, 2:86, August 2018.
- [BRC19] Peter Brown, Sammy Ragy, and Roger Colbeck. A framework for quantum-secure device-independent randomness expansion. *IEEE Transactions on Information Theory*, 66(5):2964–2987, 2019.
- [CK11] Roger Colbeck and Adrian Kent. Private randomness expansion with untrusted devices. *Journal of Physics A: Mathematical and Theoretical*, 44(9):095305, feb 2011.
- [CKR09] Matthias Christandl, Robert König, and Renato Renner. Postselection technique for quantum channels with applications to quantum cryptography. *Physical review letters*, 102(2):020504, 2009.
- [Col06] Roger Colbeck. *Quantum and relativistic protocols for secure multi-party computation*. PhD Thesis, University of Cambridge, 2006.
- [DF19] Frédéric Dupuis and Omar Fawzi. Entropy accumulation with improved second-order term. *IEEE Transactions on information theory*, 65(11):7596–7612, 2019.
- [DFR20] Frederic Dupuis, Omar Fawzi, and Renato Renner. Entropy accumulation. *Communications in Mathematical Physics*, 379(3):867–913, 2020.
- [Eke91] Artur K. Ekert. Quantum cryptography based on Bell’s theorem. *Phys. Rev. Lett.*, 67:661–663, Aug 1991.
- [FF18] Hamza Fawzi and Omar Fawzi. Efficient optimization of the quantum relative entropy. *Journal of Physics A: Mathematical and Theoretical*, 51(15):154003, 2018.
- [FF21] Hamza Fawzi and Omar Fawzi. Defining quantum divergences via convex optimization. *Quantum*, 5:387, 2021.
- [FFRS20] Kun Fang, Omar Fawzi, Renato Renner, and David Sutter. Chain rule for the quantum relative entropy. *Phys. Rev. Lett.*, 124:100501, Mar 2020.
- [FM18] Honghao Fu and Carl A Miller. Local randomness: Examples and application. *Physical Review A*, 97(3):032324, 2018.
- [Har05] Aram W Harrow. Applications of coherent classical communication and the Schur transform to quantum information theory. *arXiv preprint quant-ph/0512255*, 2005.
- [KZB20] Emanuel Knill, Yanbao Zhang, and Peter Bierhorst. Generation of quantum randomness by probability estimation with classical side information. *Phys. Rev. Research*, 2:033465, Sep 2020.

- [LKDW18] Felix Leditzky, Eneet Kaur, Nilanjana Datta, and Mark M Wilde. Approaches for approximate additivity of the Holevo information of quantum channels. *Physical Review A*, 97(1):012332, 2018.
- [LLR⁺21] Wen-Zhao Liu, Ming-Han Li, Sammy Ragy, Si-Ran Zhao, Bing Bai, Yang Liu, Peter J Brown, Jun Zhang, Roger Colbeck, Jingyun Fan, et al. Device-independent randomness expansion against quantum side information. *Nature Physics*, 17(4):448–451, 2021.
- [MLDS⁺13] Martin Müller-Lennert, Frédéric Dupuis, Oleg Szehr, Serge Fehr, and Marco Tomamichel. On quantum Rényi entropies: A new generalization and some properties. *Journal of Mathematical Physics*, 54(12), 2013.
- [MR22] Tony Metger and Renato Renner. Entropy accumulation for quantum key distribution, 2022. Manuscript forthcoming.
- [MS16] Carl A Miller and Yaoyun Shi. Robust protocols for securely expanding randomness and distributing keys using untrusted quantum devices. *Journal of the ACM (JACM)*, 63(4):1–63, 2016.
- [MS17] Carl A Miller and Yaoyun Shi. Randomness in nonlocal games between mistrustful players. *Quantum information & computation*, 17(7):595, 2017.
- [PAM⁺10] Stefano Pironio, Antonio Acín, Serge Massar, A Boyer de La Giroday, Dzmitry N Matsukevich, Peter Maunz, Steven Olmschenk, David Hayes, Le Luo, T Andrew Manning, et al. Random numbers certified by bell’s theorem. *Nature*, 464(7291):1021–1024, 2010.
- [Pet86] Dénes Petz. Sufficient subalgebras and the relative entropy of states of a von Neumann algebra. *Communications in Mathematical Physics*, 105(1):123–131, 1986.
- [Ren08] Renato Renner. Security of quantum key distribution. *International Journal of Quantum Information*, 6(01):1–127, 2008.
- [Sut18] David Sutter. *Approximate Quantum Markov Chains*. Springer, 2018.
- [TCR09] M. Tomamichel, R. Colbeck, and R. Renner. A fully quantum asymptotic equipartition property. *IEEE Transactions on Information Theory*, 55(12):5840–5847, Dec 2009.
- [Tom15] Marco Tomamichel. *Quantum information processing with finite resources: mathematical foundations*, volume 5. Springer, 2015.
- [Uhl76] A. Uhlmann. The “transition probability” in the state space of a $*$ -algebra. *Reports on Mathematical Physics*, 9(2):273–279, 1976.
- [VV12] Umesh Vazirani and Thomas Vidick. Certifiable quantum dice: or, true random number generation secure against quantum adversaries. In *Proceedings of the forty-fourth annual ACM symposium on Theory of computing*, pages 61–76, 2012.
- [Wat18] John Watrous. *The theory of quantum information*. Cambridge university press, 2018.
- [WWY14] Mark M. Wilde, Andreas Winter, and Dong Yang. Strong converse for the classical capacity of entanglement-breaking and Hadamard channels via a sandwiched Rényi relative entropy. *Communications in Mathematical Physics*, 331(2):593–622, 2014.

[ZFK20] Yanbao Zhang, Honghao Fu, and Emanuel Knill. Efficient randomness certification by quantum probability estimation. *Phys. Rev. Research*, 2:013016, Jan 2020.

A Dual statement for smooth max-entropy

In the main text we have focused on deriving a lower bound on the smooth min-entropy. Here, we show that this also implies an upper bound on the smooth max-entropy by applying a simple duality relation between min- and max-entropy. A similar upper bound was also derived in [DFR20]. However, that bound is subject to a Markov condition and cannot be derived by a simple duality argument since the “dual version” of the Markov condition is unwieldy. We show that the bound from [DFR20] follows as a special case of our more general bound even without any Markov conditions or other non-signalling constraints. For simplicity, we restrict ourselves to an asymptotic statement without “testing”, i.e. we derive an H_{\max}^ε -version of [Theorem 4.1](#). By applying the same duality relation to the more involved statement in [Theorem 4.3](#), one can also obtain an H_{\max}^ε -bound with explicit constants and testing.

Recall that for $\rho_{AB} \in \mathcal{S}(AB)$ and $\varepsilon \in [0, 1]$, the ε -smoothed max-entropy of A conditioned on B is defined as

$$H_{\max}^\varepsilon(A|B)_\rho = \log \inf_{\tilde{\rho}_{AB} \in \mathcal{B}_\varepsilon(\rho_{AB})} \sup_{\sigma_B \in \mathcal{S}(B)} \left\| \tilde{\rho}_{AB}^{\frac{1}{2}} \sigma_B^{\frac{1}{2}} \right\|_1^2,$$

where $\|\cdot\|_1$ denotes the trace norm and $\mathcal{B}_\varepsilon(\rho_{AB})$ is the ε -ball around ρ_{AB} in terms of the purified distance [[Tom15](#)]. The smooth min- and max-entropy satisfy the following duality relation [[Tom15](#), Proposition 6.2]: for a pure quantum state ψ_{ABC} ,

$$H_{\min}^\varepsilon(A|B)_\psi = -H_{\max}^\varepsilon(A|C)_\psi.$$

For the setting of [Theorem 4.1](#), let $V_i : R_{i-1}E_{i-1} \rightarrow A_iR_iE_iF_i$ be the Stinespring dilation of the map \mathcal{M}_i , and let $|\rho^0\rangle_{R_0E_0F_0}$ be a purification of the input state $\rho_{R_0E_0}^0$. Then, $V_n \cdots V_1|\rho^0\rangle$ is a purification of $\mathcal{M}_n \circ \cdots \circ \mathcal{M}_1(\rho^0)$, so by the duality of the smooth min- and max-entropy,

$$H_{\min}^\varepsilon(A^n|E_n)_{\mathcal{M}_n \circ \cdots \circ \mathcal{M}_1(\rho^0)} = -H_{\max}^\varepsilon(A^n|F^n R_n)_{V_n \cdots V_1|\rho^0}.$$

Furthermore, by concavity of the conditional entropy the infimum in [Theorem 4.1](#) can be restricted to pure states $|\omega\rangle_{R_{i-1}E_{i-1}\tilde{E}_{i-1}}$, so $V_i|\omega\rangle$ is a purification of $\mathcal{M}_i(\omega)$. Then, by the duality relation for von Neumann entropies,

$$H(A_i|E_i\tilde{E}_{i-1})_{\mathcal{M}_i(\omega)} = -H(A_i|R_iF_i)_{V_i|\omega}.$$

Therefore, we obtain the following dual statement to [Theorem 4.1](#):

$$H_{\max}^\varepsilon(A^n|F^n R_n)_{V_n \cdots V_1|\rho^0} \leq \sum_{i=1}^n \max_{|\omega\rangle} H(A_i|R_iF_i)_{V_i|\omega} + O(\sqrt{n}), \quad (\text{A.1})$$

where the maximisation is over pure states on $R_{i-1}E_{i-1}\tilde{E}_{i-1}$. This holds for any sequence of isometries V_i for which the maps $\mathcal{M}_{V_i} : R_{i-1}E_{i-1} \rightarrow A_iR_iE_i$ given by $\mathcal{M}_{V_i}(\rho) = \text{Tr}_{F_i}[V_i\rho V_i^\dagger]$ satisfy the non-signalling condition of [Theorem 4.1](#): for each i , there must exist a map $\mathcal{R}_i \in \text{CPTP}(E_{i-1}, E_i)$ such that $\text{Tr}_{A_iR_i} \circ \mathcal{M}_{V_i} = \mathcal{R}_i \circ \text{Tr}_{R_{i-1}}$.

To gain some intuition for the above statement, consider a setting where an information source generates systems A_1, \dots, A_n and F_1, \dots, F_n by applying isometries $V_i : S_{i-1} \rightarrow A_i F_i S_i$ to some pure initial state $|\rho^0\rangle_{S_0}$. We might be interested in compressing the information in A^n in such a way that given F^n , one can reconstruct A^n except with some small failure probability ε . Then, the amount of storage needed for the compressed information is given by $H_{\max}^\varepsilon(A^n|F^n)$. To apply Equation (A.1), for $i < n$ we split the systems S_i into $R_i E_i$ in such a way that the channel \mathcal{M}_{V_i} defined above satisfies the non-signalling condition, and set $E_n = S_n$ (so that R_n is trivial). Then Equation (A.1) gives an upper bound on $H_{\max}^\varepsilon(A^n|F^n)$. Note that this bound depends on how we split the systems $S_i = R_i E_i$: the non-signalling condition can always be trivially satisfied by choosing R_i to be trivial, but Equation (A.1) tells us that if we can describe the source in such a way that E_i is relatively small and R_i is relatively large while still satisfying the non-signalling condition, we obtain a tighter bound on the amount of required storage.

From Equation (A.1) we can also recover the max-entropy version of the original EAT, but without requiring a Markov condition. To facilitate the comparison with [DFR20], we first re-state their theorem with their choice of system labels, but add a bar to every system label to avoid confusion with our notation from before. The max-entropy statement in [DFR20] considers a sequence of channels $\bar{\mathcal{M}}_i : \bar{R}_{i-1} \rightarrow \bar{A}_i \bar{B}_i \bar{R}_i$ and asserts that under a Markov condition, for any initial state $\rho_{R_0 \bar{E}}$ with a purifying system $\bar{E} \equiv \bar{R}_0$:

$$H_{\max}^\varepsilon(\bar{A}^n | \bar{B}^n \bar{E})_{\bar{\mathcal{M}}_n \circ \dots \circ \bar{\mathcal{M}}_1(\rho_{R_0 \bar{E}})} \leq \sum_{i=1}^n \max_{\omega \in \mathcal{S}(\bar{R}_{i-1} \bar{R}_i)} H(\bar{A}_i | \bar{B}_i \bar{R})_{\bar{\mathcal{M}}_i(\omega)} + O(\sqrt{n}), \quad (\text{A.2})$$

where $\bar{R} \equiv \bar{R}_{i-1}$. We want to recover this statement from Equation (A.1) *without any Markov condition*. For this, we consider the Stinepring dilations $\bar{V}_i : \bar{R}_{i-1} \rightarrow \bar{R}_i \bar{A}_i \bar{B}_i \bar{E}_i$ of $\bar{\mathcal{M}}_i$. We make the following choice of systems:

$$R_i = \bar{B}^i \bar{E}, \quad A_i = \bar{A}_i, \quad E_i = \bar{R}_i \bar{E}_i,$$

and choose F_i to be trivial. By tensoring with the identity, we can then extend \bar{V}_i to an isometry $V_i : R_{i-1} E_{i-1} \rightarrow A_i R_i E_i$. Then, the maps \mathcal{M}_{V_i} satisfy the non-signalling condition since V_i acts as identity on R_{i-1} . Therefore, remembering that $R_n = \bar{B}^n \bar{E}$ and F^n is trivial, we see that Equation (A.1) implies Equation (A.2). Note that our derivation did not require any conditions on the channels $\bar{\mathcal{M}}_i$ we started with, i.e. we have shown Equation (A.2) holds for any sequence of channels $\bar{\mathcal{M}}_i$, not just channels satisfying a Markov or non-signalling condition.

B Uhlmann property for the Rényi divergence

We establish that for the max-divergence (where $\alpha \rightarrow \infty$), Uhlmann's theorem holds.

Proposition B.1. *Let $\sigma_A \in \mathcal{S}(A)$ and $\rho_{AE} \in \mathcal{S}(AE)$. Then we have*

$$D_{\max}(\rho_A \| \sigma_A) = \inf_{\hat{\sigma}_{AR} : \hat{\sigma}_A = \sigma_A} D_{\max}(\rho_{AR} \| \hat{\sigma}_{AR}). \quad (\text{B.1})$$

In addition, if $\rho_{AR}, \rho_A \otimes \text{id}_R$ and $\sigma_A \otimes \text{id}_R$ all commute, then for any $\alpha \in [\frac{1}{2}, \infty)$, we have

$$D_\alpha(\rho_A \| \sigma_A) = \inf_{\hat{\sigma}_{AR} : \hat{\sigma}_A = \sigma_A} D_\alpha(\rho_{AR} \| \hat{\sigma}_{AR}). \quad (\text{B.2})$$

Proof. We start with Equation (B.1). The inequality \leq is a direct consequence of the data-processing inequality for D_{\max} . For the inequality \geq , we use semidefinite programming duality, see e.g., [Wat18]. Observe that we can write $2^{D_{\max}(\rho_A \parallel \sigma_A)}$ as the following semidefinite program

$$\min_{\tau_A \in \text{Pos}(A), \lambda \in \mathbb{R}} \{ \text{Tr}[\tau_A] : \rho_A \leq \tau_A, \tau_A = \lambda \sigma_A \}.$$

Using semidefinite programming duality, this is also equal to

$$\max_{X_A \in \text{Pos}(A), Y_A \in \text{Herm}(A)} \{ \text{Tr}[X_A \rho_A] : \text{id}_A + Y_A = X_A, \text{Tr}[Y_A \sigma_A] = 0 \}. \quad (\text{B.3})$$

We can also write a semidefinite program for $\inf_{\hat{\sigma}_{AR} : \hat{\sigma}_A = \sigma_A} 2^{D_{\max}(\rho_{AR} \parallel \hat{\sigma}_{AR})}$. We introduce the variable $\theta_{AR} = \lambda \hat{\sigma}_{AR}$ and get

$$\min_{\tau \in \text{Pos}(A \otimes R), \lambda \in \mathbb{R}} \{ \text{Tr}[\tau_{AR}] : \rho_{AR} \leq \tau_{AR}, \theta_A = \lambda \sigma_A \}.$$

Again, by semidefinite programming duality, we get that it is equal to

$$\max_{X_{AR} \in \text{Pos}(A \otimes R), Y_A \in \text{Herm}(A)} \{ \text{Tr}[X_{AR} \rho_{AR}] : (\text{id}_A + Y_A) \otimes \text{id}_R = X_{AR}, \text{Tr}[Y_A \sigma_A] = 0 \}. \quad (\text{B.4})$$

Eliminating the variable X_{AR} , we can write this last program as

$$\max_{Y_A \in \text{Herm}(A)} \{ \text{Tr}[(\text{id}_A + Y_A) \rho_A] : \text{id}_A + Y_A \in \text{Pos}(A), \text{Tr}[Y_A \sigma_A] = 0 \},$$

which is the same as Equation (B.3). This proves Equation (B.1). Equation (B.2) follows immediately by choosing $\hat{\sigma}_{AR} = \sigma_A \rho_A^{-1} \rho_{AR}$ and using the commutation conditions. \square

However, for $\alpha \geq 1$ and arbitrary $\sigma_A \in \mathcal{S}(A)$, $\rho_{AE} \in \mathcal{S}(AE)$, the Uhlmann property given by Equation (B.2) does not hold. A concrete example is $\rho_{AR} = |\psi\rangle\langle\psi|_{AR}$ with

$$|\psi\rangle_{AR} = \sqrt{\frac{1}{4}}|00\rangle_{AR} + \sqrt{\frac{3}{4}}|11\rangle_{AR}$$

and $\sigma_A = \frac{1}{3}|+\rangle\langle+| + \frac{2}{3}|-\rangle\langle-|$. In this case, $D_2(\rho_A \parallel \sigma_A) < 0.476$ whereas

$$\inf_{\hat{\sigma}_{AR} : \hat{\sigma}_A = \sigma_A} D_2(\rho_{AR} \parallel \hat{\sigma}_{AR}) \geq \inf_{\hat{\sigma}_{AR} : \hat{\sigma}_A = \sigma_A} D(\rho_{AR} \parallel \hat{\sigma}_{AR}) > 0.48.$$

This computation was performed by numerically solving the semidefinite programs via CVXQUAD [FF18]. Putting everything together shows that Equation (B.2) does not hold for $\alpha \in \{1, 2\}$:

$$D(\rho_A \parallel \sigma_A) \leq D_2(\rho_A \parallel \sigma_A) < \inf_{\hat{\sigma}_{AR} : \hat{\sigma}_A = \sigma_A} D(\rho_{AR} \parallel \hat{\sigma}_{AR}) \leq \inf_{\hat{\sigma}_{AR} : \hat{\sigma}_A = \sigma_A} D_2(\rho_{AR} \parallel \hat{\sigma}_{AR}).$$