

Language vs Speaker Change: A Comparative Study

Jagabandhu Mishra^{1, a} and S. R. Mahadeva Prasanna^{1, b}

Department of Electrical Engineering, IIT Dharwad, Dharwad 580011, Karnataka, India.

(Dated: 8 March 2022)

Spoken language change detection (LCD) refers to detecting language switching points in a multilingual speech signal. Speaker change detection (SCD) refers to locating the speaker change points in a multispeaker speech signal. The objective of this work is to understand the challenges in LCD task by comparing it with SCD task. Human subjective study for change detection is performed for LCD and SCD. This study demonstrates that LCD requires larger duration spectro-temporal information around the change point compared to SCD. Based on this, the work explores automatic distance based and model based LCD approaches. The model based ones include Gaussian mixture model and universal background model (GMM-UBM), attention, and Generative adversarial network (GAN) based approaches. Both the human and automatic LCD tasks infer that the performance of the LCD task improves by incorporating more and more spectro-temporal duration.

©2022 Acoustical Society of America. [[https://doi.org\(DOI number\)](https://doi.org(DOI number))]

[XYZ]

Pages: 1–12

I. INTRODUCTION

Spoken language diarization (SLD) is a task to automatically segment and label the monolingual segments in a given multilingual speech signal. The existing works towards SLD are very few (Sitaram *et al.*, 2019). Majority of them use phonotactic (i.e. the distribution of sound units) based approaches (Chan *et al.*, 2004; Lyu *et al.*, 2013; Spoorthy *et al.*, 2018). The development of SLD using a phonotactic-based approach requires transcribed speech utterances. The same is difficult to obtain as most of the languages present in the code-switched multilingual utterances are resource-scare in nature (Li *et al.*, 2013; Spoorthy *et al.*, 2018). Hence there is a need for exploring alternative approaches for SLD. For this the speaker diarization (SD) work may come handy. SD is a task to automatically segment and label the speaker identity for a given multispeaker utterance. Further, most of the approaches used for spoken language recognition are the modified and time-delayed versions of the approaches used to perform the speaker recognition task (Richardson *et al.*, 2015; Snyder *et al.*, 2018). This motivates for a close association between SLD and SD tasks and may be exploited to come up with approaches for SLD.

The SD field has evolved mainly in two ways: (1) change point detection followed by clustering and boundary refinement, and (2) fixed duration segmentation followed by i-vector/ embedding vector extraction, clustering and boundary refinement (Moattar and Homyounpour, 2012; Park *et al.*, 2022; Tranter and Reynolds, 2006). It has been observed from the literature that the initial change point detection is an important stage to improve the overall SD performance (Dawalatabad *et al.*,

2020). Therefore a change point detection based approach for SLD is an interesting alternative compared to the phonotactic approach. Thus this study focuses on the development of spoken language change detection (LCD) through a comparative analysis between LCD and speaker change detection (SCD). Even though the framework seems simple to adopt, there are challenges in doing so. Around the speaker change, there are significant changes in terms of excitation source, vocal tract system and suprasegmental information. However, around the language, there are only minimal changes due only to information available at suprasegmental levels. Thus it will be more challenging to do LCD compared to SCD.

Fig. 1 (a) and (b), show the time domain speech signals corresponding to the utterance having speaker change and language change, respectively. The manual identified change points are marked. From the time domain signal, it is very difficult to locate both the speaker and language change points. Fig. 1 (c) and (d) show the spectrogram of both the utterances. Around the speaker change, there exist changes in the excitation source, vocal tract and suprasegmental information which may provide enough evidence to detect the speaker change. On the other hand, as a single speaker is speaking both the languages, these changes are not visible. Hence the challenge in LCD compared to SCD.

It is interesting to note that humans discriminate between spoken languages without knowing the lexical rules and phonemic distribution of the respective languages. Of course humans need to have some prior exposure to the languages (Li *et al.*, 2013). Humans may exploit the long term spectro-temporal relations to discriminate between languages. Motivating from the same, SLD system can also be developed using acoustic-phonetic information exploited at suprasegmental levels (Liu *et al.*, 2021; Zhang, 2013). The advantage of the acoustic-phonetic

^ajagabandhu.mishra.18@iitdh.ac.in

^bprasanna@iitdh.ac.in

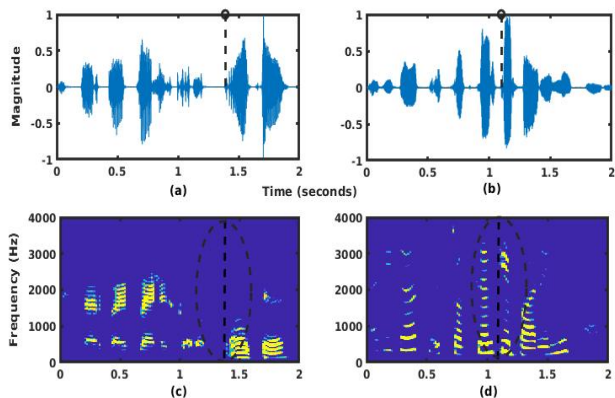

FIG. 1. (a) and (c) Two speaker time domain speech signal and its spectrogram, respectively. (b) and (d) Two language (Bilingual) time domain speech signal and its spectrogram, respectively.

based approach is, it does not require transcribed speech data.

Based on the need to exploit the long term spectro-temporal evidence, it is hypothesized that the LCD requires more neighborhood information around the change point than the SCD. To validate the same, a human subjective study will be performed to detect the language and speaker changes. Further, automatic change point detection methods based on distance based approaches and model based approaches are carried out. The model based approaches include Gaussian mixture model - universal background model (GMM-UBM), attention and GAN based approaches (Chen *et al.*, 2020; Raffel and Ellis, 2015; Reynolds, 1995). All these modeling approaches working principles are different and hence exploit the long term information in different ways to model the change points.

The rest of the article is organized as follows: Section II describes human change point detection studies performed. The unsupervised distance based approach explored for LCD are described in Section III. The model based approaches are explained in Section IV. The experimental setup results and discussion are given in Section V. The work summarized and concluded in Section VI.

II. LANGUAGE AND SPEAKER CHANGE DETECTION BY HUMANS

The subjective study is to show that humans may require more neighborhood duration around change point to discriminate between languages than speakers. An experimental procedure where the human subjects are exposed to the pool of utterances that may or may not have language / speaker change. The subjects are asked to mark, if there exists a language / speaker change or not. The utterances are classified into five groups. Each group is represented with approximate duration considered in

terms of the number of voiced frames taken around the true/false change point.

The dataset used for this study consists of 15 utterances having language change and 15 utterances having speaker change. The language change utterance from the Multilingual and code-switched (MUCS2021) Hindi-English corpus (Diwan *et al.*, 2021) and the speaker change utterances are selected from IITG-MV phase 3 and DIHARD dataset (Haris *et al.*, 2012; Ryant *et al.*, 2018). The selected two-language and two-speaker utterances are split around the change point to generate 30 mono utterances in each case. Out of 30, after listening, best 15 for each case have been chosen for this study. For two- language or speaker utterances actual change points are termed as true change point and for mono language or speaker utterance, the starting point of the middle voiced frame is termed as false change point. After that, each utterance $S(n)$ are masked by considering x number of voiced frames (NVF- x) from the left and right of the true/false change point. To detect the voiced frames, a short time energy (STE) based approach has been used with a frame size of 20 msec and a frame shift of 10 msec (Rabiner, 1978). According to the value of x , the masked utterances are grouped into five different groups, termed as NVF-10, NVF-20, NVF-30, NVF-50 and NVF-75. To avoid abrupt masking, a Gaussian mask $G(n)$ with appropriate parameters is multiplied with the utterances to obtain the masked utterance $S_m(n) = S(n) \times G(n)$. the masked signal is passed through a energy based endpoint detection algorithm to obtain the final masked utterance (Rabiner, 1978). The detailed procedure of masked segment generation is attached in supplementary¹, and also generated segments are available at <https://github.com/jagabandhumishra/Speaker-and-Language-change-detection-by-human>

The listening experiment has been conducted with 10 subjects. The subjects are chosen such that they have previous exposure to the languages present in the chosen utterances. For the listening study each listener has to listen to 300 segments (i.e 150 each for language change and speaker change). Taking care of the comfortability of listeners, the listening study has been conducted in two sessions, one session for language change study and another for speaker change study. To avoid any perceptual discomfort, the subjects are advised to maintain at least 3 to 4 hours of gap between the sessions. A graphical user interface (GUI) has been designed to perform the listening study. For a specific language/speaker change study, all the 150 masked utterances are presented to the listener in a random order, irrespective of their segment duration. If the listener is unable to provide the response for one time playing, s/he is allowed to play the utterance multiple times. Motivated from the study reported in (Sharma *et al.*, 2019), three kinds of responses have been recorded. These are (1) language / speaker change detected or not (2) number of time replayed (NR) and (3) response time (RT). RT is the time duration taken by a subject to provide his/her response, after listening to the full utterance. The duration taken by a subject (i.e.

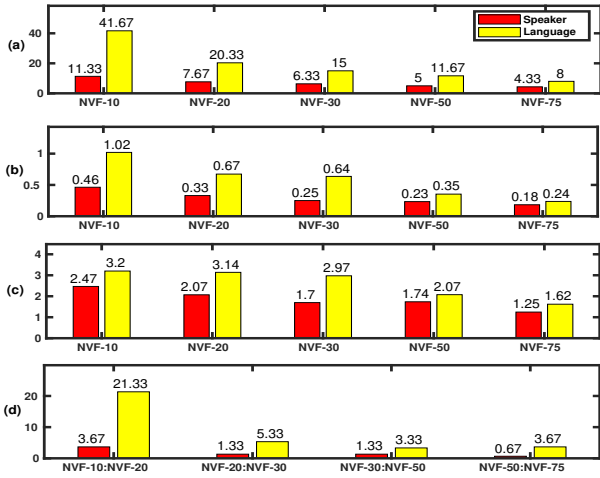

FIG. 2. Subjective study performance: (a) %DER, (b) NR, (c) RT and (d) %absolute deviation DER.

from pressing play button to pressing yes/no button) to provide his/her response (termed as total duration (TD)) is recorded through GUI. The RT is computed by subtracting the respective utterance duration (UD) from the TD (i.e. $RT = TD - UD$).

$$DER = \sum_{s=1}^{N_s} \frac{(FA_s + FR_s) \times 100}{N_s \times N} \quad (1)$$

There are three kinds of performance measures used in this study: (1) average detection error rate (DER) (2) average number of times replayed (NR) and (3) average response time (RT). The DER is defined in Eq. 1, where N_s is the number of subjects participated in this study, N is the total number of trails, FA is the number of false language/ speaker change segments, marked as true by the listener and FR is the number of true language / speaker change segments, marked as false by the listener. The DER measure defines the inability of the listeners to detect language / speaker change. The NR, provides an estimation of the average number of replay's required to the subjects to mark his response comfortably. Similarly the RT provides an estimation of average duration required for the subjects to perceive the language / speaker change, after listening to the respective utterances. Higher value of the performance measures indicates inability of the human subject to perceive the language / speaker and vice versa.

The obtained performance measures from the human subjective study for different groups of masked utterances are depicted in Fig. 2. The values of all three performance measures decrease with increase in the number of voiced frames (i.e. from NVF-10 to NVF-75) around the true/false change point. This hints that the ability of human subjects to perceive the language and speaker change increases with increase in the number of voiced frames. With respect to DER, it can be ob-

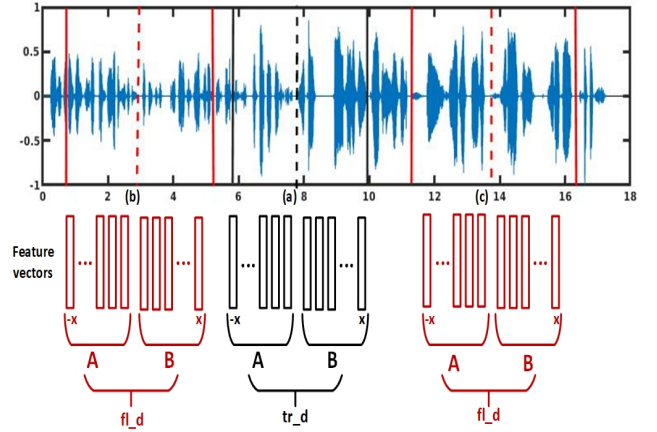

FIG. 3. Distance computation around the true and false change point of an utterance, (a) true change point and (b), (c) false change points, fl_d and tr_d are F_d and T_d respectively.

served that, irrespective of the group, human subjects are able to better perceive the speaker change than the language change. Fig 2(b) and (c) shows irrespective of the group, human subjects are less confused to provide their response for speaker change study than the language change study (as the NR and RT values are less in speaker than the language change study). Fig 2(d) shows the absolute deviation in the DER with respect to the groups for both speaker and language change studies. The absolute deviation in the DER saturates beyond NVF-30 for speaker change study and at NVF-50 for language change study. This indicates, beyond 30 voiced frames for speaker change and 50 voiced frames for language change, the perceptual ability to detect speaker and language change increases with increase in number of voiced frames, but not that significant. Taking these observations, we can conclude human cognition requires a larger duration around the change point to perform LCD than SCD.

III. LANGUAGE AND SPEAKER CHANGE DETECTION BY DISTANCE BASED APPROACH

Motivated by the subjective study described earlier, this section describes a cepstral distance based automatic framework for performing LCD and SCD. The hypothesis is that the with language / speaker change may be attributed to difference in the cepstral distance having higher values than the no change cases. Further, increase in voiced frames may lead to increase in the positive separation between the distance distribution obtained around the true change (T_d) than the false change (F_d).

The same set of utterances used in subjective study are considered here. With respect to the number of voiced frames x around the change point, the analysis is performed in five groups (i.e. $\{NVF - x : x = \{10, 20, 30, 50, 75\}\}$). Given an utterance and the value

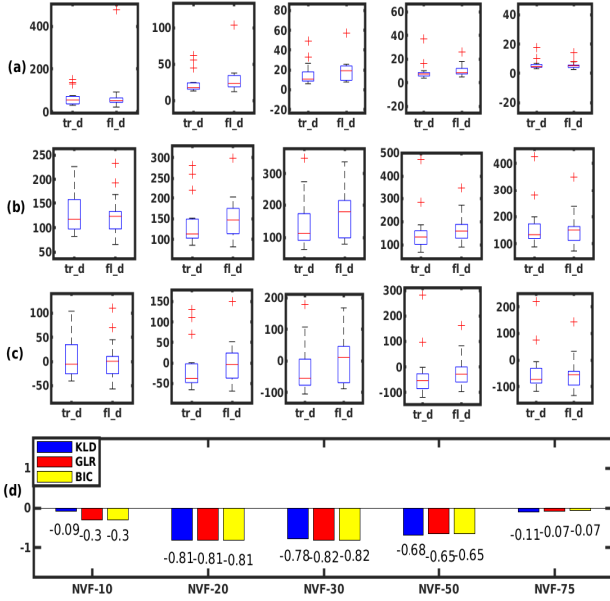

FIG. 4. Distance distribution around true and false language change point: (a) Symmetric KL divergence, (b) GLR, (c) BIC ($\lambda = 0.1$) and (d) CD values, fl.d and tr.d are F_d and T_d respectively.

of x , the detailed procedure of T_d and F_d computation is depicted in Fig. 3. An utterance having a true change at point (a) has been shown in Fig. 3. Splitting the utterance around the point (a) generates two mono segments. The starting point of the mid-voiced frame of the mono segments is used as the false-voiced points (i.e. (b) and (c)). For a specific analysis group (i.e. NVF- x), the MFCC- $\Delta - \Delta\Delta$ feature vectors of the x number of voiced frames from the left and right of the true/false change point has been taken and termed as A and B segment, respectively. Then A and B can be represented as $A = \{f_{-1}, f_{-2}, \dots, f_{-x}\}$ and $B = \{f_1, f_2, \dots, f_x\}$. After that, for a given true/false change point, distance between segment A and B are computed and termed as T_d/F_d .

Three kinds of distance measures that generally used in the SCD literature, namely, (1) symmetric KL divergence (Siegler *et al.*, 1997), (2) generalized likelihood ratio (GLR) (Gish *et al.*, 1991) and (3) Bayesian information criteria (BIC) (Chen *et al.*, 1998) are used here. All three measures use Gaussian approximation of the feature vectors present in a segment. That is the feature vectors in segment A and B can be approximated as $A \sim \mathcal{N}(\mu_A, \Sigma_A)$ and $B \sim \mathcal{N}(\mu_B, \Sigma_B)$. As the number of feature vectors (i.e. between 10 to 75) are too small to estimate the full covariance matrix, this study estimates the diagonal covariance matrix (Reynolds, 1995). A measure called confidence in discrimination (CD) (inspiring from the objective function of linear discriminate analysis (LDA) (Hart *et al.*, 2000)) has been introduced here

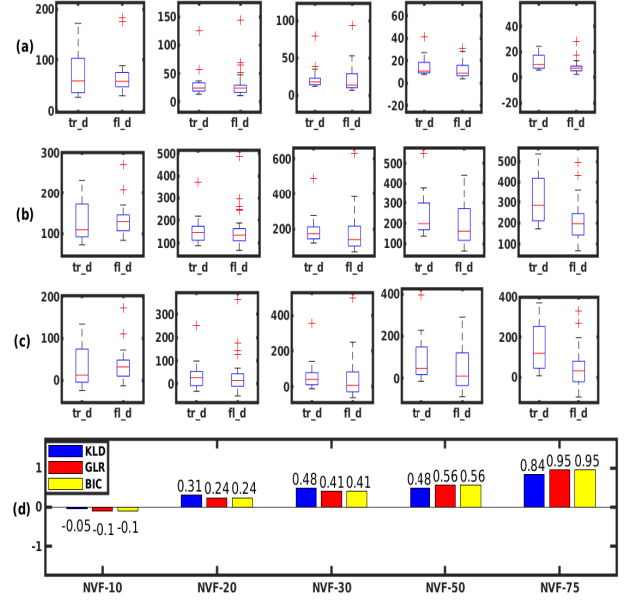

FIG. 5. Distance distribution around true and false speaker change point: (a) Symmetric KL divergence, (b) GLR, (c) BIC ($\lambda = 0.1$) and (d) CD values, fl.d and tr.d are F_d and T_d respectively.

to measure the positive separation between the distribution of T_d and F_d scores. The objective is to compute the positive separation, so square root of the LDA objective function is taken as CD measure. The CD measure is defined in Eq. 2, where μ_t , μ_f , σ_t^2 and σ_f^2 are the mean and variance of the T_d and F_d scores, respectively. The measure is expected to provide positive confidence value, if the mean of T_d distribution is higher than the mean of F_d , and increases with increase in the positive separation.

$$CD = \frac{\mu_t - \mu_f}{\sqrt{\sigma_t^2 + \sigma_f^2}} \quad (2)$$

The obtained distributions of T_d and F_d for both LCD and SCD study are depicted with box plots in Fig. 4 and 5. For LCD task, irrespective of the number of voiced frames, the mean of the F_d is higher than the mean of T_d distribution (from Fig 4(a), (b), (c), and (d)). This may be due to the cepstral features with a single Gaussian are not able approximate the language specific phonemic information. As a single speaker has spoken both the languages, so there exist no change in speaker specific vocal tract system. Again with increase in number of voiced frames, the overlap between the T_d and F_d increases (i.e. the CD values approaching to zero), that may be due to the cepstral feature with single Gaussian approximating the speaker characteristic. As both around true and false change point, there exist no change in speaker, thus the distribution of T_d and F_d approaching towards near identical. Similarly for SCD task, irrespective of the distance

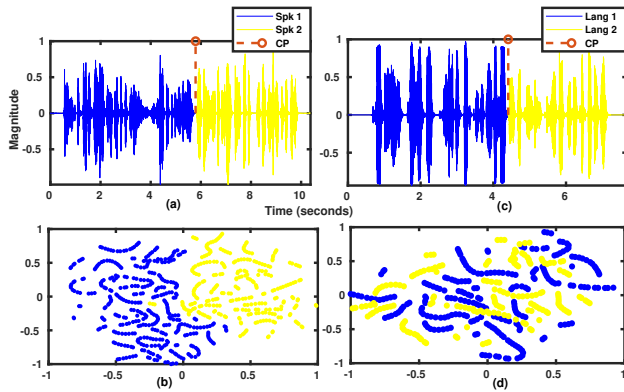

FIG. 6. (a),(b) Two speaker utterance and its MFCC features Tsne distribution and (c), (d) Two language utterance and its MFCC features Tsne distribution

measure, the positive separation between the T_d and F_d distribution increases with increase in number of voiced frames around the change point (from Fig 5(a), (b), (c), and (d)). This observation can be better remarked from bar plot of the CD measure depicted in Fig. 5(d). The CD value increases with increase in number of voiced frame around the change point. This happens due to the change in vocal tract system, which may lead to the change the speaker specific pattern of vocal tract resonances. With small number of voiced frames, the Gaussian distribution approximates to the phonemic variation may be a reason for negative CD value of NVF=10. With increase in number of voiced frames, the Gaussian distribution start approximating the speaker characteristics, may be a reason for increase in the CD values. This suggests, it is difficult to locate the language change point using the cepstral distance based approaches.

IV. LANGUAGE AND SPEAKER CHANGE DETECTION BY MODEL BASED APPROACH

The subjective study confirms the ability of human subjects to discriminate between the languages. At the same time, the objective analysis with MFCC- $\Delta - \Delta\Delta$ features showing their ineptness to discriminate between the languages. This may be due to the phonemic variation captured by MFCC- $\Delta - \Delta\Delta$ feature vectors are not that significant to discriminate between languages. Further to verify the fact, a two-dimensional projection of the feature vectors of both language and speaker change segment is depicted in Fig. 6. The feature vector's t-SNE plot shows a clear separation between the two speakers, whereas there is significant overlap in language change case. Thus when a single speaker speaks both the languages, the feature vectors are failing to capture the language specific phonemic variations. That may be due to the pronunciation based phonemic variations of the secondary language are mostly biased towards the variations of the primary language. Humans may be able to discriminate between the languages by invoking previous

exposure to the respective languages. Therefore to capture the prior language specific distribution model based approaches may be desirable.

Initially Gaussian mixture model universal background model (GMM-UBM) based approach is used and the details are discussed in section IV A. GMM-UBM along with MFCC- $\Delta - \Delta\Delta$ features can only capture the phonemic variation pattern present in the approximately 100 msec (for NDL=2 (Ambikairajah *et al.*, 2011)) voiced speech segment. But, the speech production literature tells, humans can produce four to five syllables per second (Cruttenden, 2014). That means to capture the phonemic variation for at least a syllable level requires 200 to 250 msec duration. Hence to further improve the performance, we may require a modeling technique, which is able to capture the temporal sequence information. Out of many sequence learning architectures proposed in literature (recurrent neural network (RNN) and its variants), a comparatively simple attention based architecture (Raffel and Ellis, 2015) has been used in this study and the details are discussed in section IV B.

Humans generally remember the language specific pattern and try to discriminate between languages by recall. On the other hand, the attention based architecture used here, is learned to discriminate between the language specific phonemic variation patterns of different languages, instead of implicitly learning the distribution of language specific phonemic variation patterns. To further improve the ability of language detection, out of many generative learning strategies, a generative adversarial network (GAN) based framework has been used in this study and the details are discussed in section IV C. Another motivation of choosing GAN is, it uses an implicit framework to capture the data distribution through the generator (Goodfellow, 2016).

The model based study has been conducted with a limited amount of vocabulary of each language. 327 utterances has been chosen from the MUCS2021 Hindi-English dataset which has only one language change point and has at least 3 – 4 syllables from each language. The language change point and language labels are manually annotated. The utterances are randomly split with 70% – 30% to generate the train and test set. For all the studies MFCC- $\Delta - \Delta\Delta$ features are used. The manually annotated utterances and its corresponding change point annotations are available at https://github.com/jagabandhumishra/Annotated_files_MUCS_HE.

A. GMM-UBM based approach

An UBM model of cluster size 256 is trained using the utterances present in the training set. After that, the utterances are split into Hindi and English subset, using the information of corresponding utterance's change point and language annotations. Then, the Hindi and English subset is used for modeling the language specific adaptation models (Wong and Sridharan, 2002). As, the chosen code-switched utterances are consist of two languages (i.e. Hindi and English), during testing, the frame

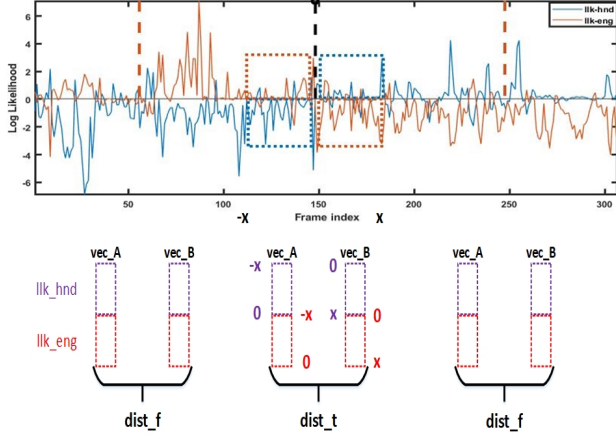

FIG. 7. Procedure to compute distance from the obtained likelihood contour of an utterance, $dist_t$ and $dist_f$ are dst_t and dst_f respectively.

wise likelihood contour ($llk_h(x_i)$ and $llk_e(x_i)$) is computed, where i indicates the frame index.

The study use two approaches: (a) distance based (dst) and (b) likelihood deviation based (ldv) to show the ability of GMM-UBM approach to perform LCD task. For a given test utterance, the true and false segments have been generated as shown in Fig. 3. In distance based approach, For a given true/ false segment, the vec_A and vec_B is computed as, $vec_A = \{llk_h(A), llk_e(A)\}$ and $vec_B = \{llk_h(B), llk_e(B)\}$. After that the distance between the vectors is computed as $dst = \|vec_A - vec_B\|_2^2$. Ideally, during the change, the likelihood contour should exhibit a cross over (as shown in Fig. 7), hence assumed that dst_t distribution has higher values than the dst_f distribution. Similarly, in likelihood deviation based approach, for a given analysis group (i.e. NVF- x), the ldv is computed as per Eq. 3. Where f_i are the feature vectors around the change point. Ideally, around the change point, there exist a sudden change (either drop/ increase) in the cumulative likelihood evidence for a specific language. Therefore it is hypothesized that, the ldv_t distribution has higher values than the ldv_f distribution. With increase in x around the change point, the CD measure for both the measure should increase, as with increase in number of voiced frames. The obtained true and false distribution for both the measures and their corresponding CD values are shown in Fig. 11(a),(d) and Fig. 12(a),(d), respectively.

$$ldv = \frac{1}{2} \left(\left| \sum_{i=1}^x llk_h(f_{-i}) - \sum_{i=1}^x llk_h(f_i) \right| + \left| \sum_{i=1}^x llk_e(f_{-i}) - \sum_{i=1}^x llk_e(f_i) \right| \right) \quad (3)$$

The figure shows that, irrespective of the number of voiced frames around the change point, the median of

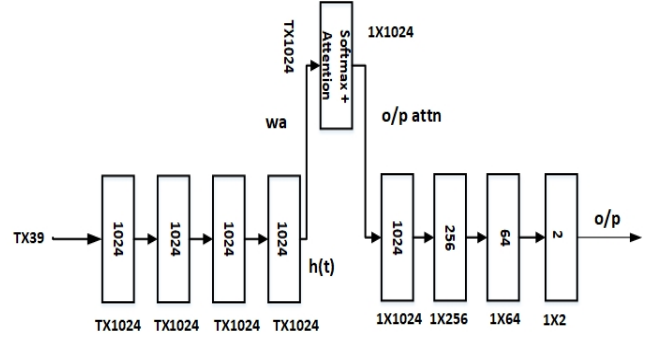

FIG. 8. Attention based network architecture

both dst_t and ldv_t is higher than the median of dst_f and ldv_f distribution. Also can be observed that, irrespective of the measure, with increase in number of voiced frames, the positive separation between the true to false distribution increases. This leads to an increase in the CD and demonstrates the ability of the GMM-UBM approach to perform LCD task.

B. Attention based approach

This study uses an attention based architecture consisting of 7 hidden layers and one attention layer. The network has 39 input layer neurons and 2 output layer neurons. First four layers consist of 1024 neurons each and designed to operate at frame level. The output of the forth hidden layer has passed through the attention layer to capture the temporal dynamic information in segment level (Siddhartha *et al.*, 2020). The attention architecture and the flow of feature vectors through the different layers of the architecture is shown in Fig. 8. As mentioned in our previous work, the network has been trained to capture the temporal segment information present in 50 voiced frames (i.e. approximately 500 msec) (Mishra *et al.*, 2021). The network has been trained for 50 epochs with an Adam optimizer and a learning rate of 0.001. After observing the training and validation loss and accuracy, the model corresponding to the 12th epoch is chosen for further study.

The distance distribution (dst_t and dst_f), has been computed from the output contour extracted from the attention network. The outputs are the linear outputs from the attention network's output layer. As the network is trained with 50 voiced frames, so during testing, the output contour is extracted for frame shift by considering 50 frame context. The center frame index of the context segment is used as the frame index. The extracted output contour for an utterance along with its corresponding ground truth change point is shown in Fig 10(b).

$$ldv = \frac{1}{2} \left(\left| \log \left(\frac{F(A|\lambda_h)}{F(B|\lambda_h)} \right) \right| + \left| \log \left(\frac{F(A|\lambda_e)}{F(B|\lambda_e)} \right) \right| \right) \quad (4)$$

The ldv measure is computed from the output of the attention network as mentioned in Eq. 4, where $F(A|\lambda_h)$ denotes the softmax output of the Hindi node for an input segment A . For a specific value of x (NVF- x), $A = \{f_{-x}, \dots, f_{-1}\}$. Ideally similar to the GMM-UBM approach, the ldv_t distribution has higher values than the ldv_f distribution. And also with increase in x value, the positive deviation between the two distributions increases. This leads to the increment of CD values with increase in x . The obtained true and false distribution for both the measures and their corresponding CD values are shown in Fig 11(b),(d) and Fig 12(b),(d), respectively.

From the plot it can be observed that, irrespective of the analysis group and measures, the CD values are positive. This signifies the ability of the approach to detect the language change. It can also be observed that, with an increase in the number of voiced frames around the change point the CD value increases which signifies that the true distribution has higher positive deviation from the false distribution. Compared to the GMM-UBM based approach, it can be observed by comparing the CD values depicted in Fig. 11(d) and Fig. 12(d), that the attention based approach has higher positive deviation between the true and false distributions. This is better evident from the Fig. 10(a) and (b). The confidence in detecting a language is higher in case of attention based approach than the GMM-UBM based approach. Only at the NVF-10 analysis group, the CD value for both the measures are smaller than the GMM-UBM based approach. This may be due to the attention network trained with 10 voiced frames may not be able to capture appropriate language specific information. This shows the importance of temporal modeling towards detecting language change points.

C. GAN based approach

There are many variants of GAN architectures proposed in the speech processing literature (Goodfellow, 2016). Out of them, the auxiliary classifier conditional GAN (ACGAN) has been extensively used for classification tasks (Shen et al., 2017). The ACGAN framework that is used in this work is depicted in Fig. 9. For comparison, the feature extraction and the discriminator architecture have been kept the same with the attention based study, except the discriminator has an extra single neuron output. The single neuron output along with sigmoid activation is responsible for real/fake classification. The generator architecture has been decided by keeping in mind that the generator is able to capture the class specific feature distribution with less amount of training data. Hence, instead of randomly exciting the generator, the feature vectors used to train the discriminator are used to excite the generator (Chen et al., 2020). The generator architecture is an encoder-decoder architecture, which uses gated convolutional units and pixel shufflers. The gated convolutional units (GCNN) better encodes the temporal dependency information and the

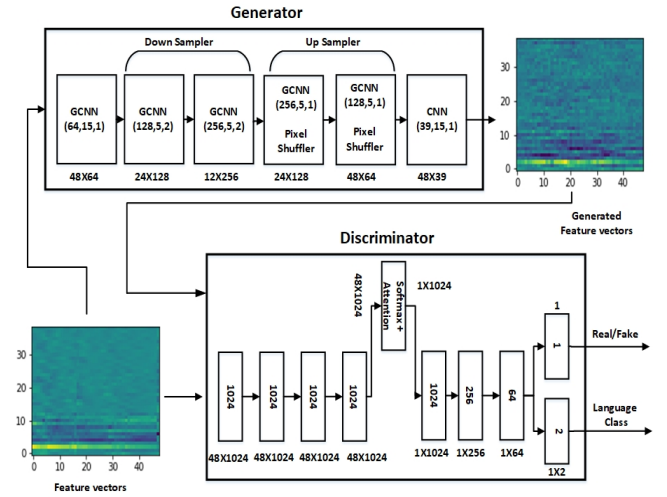

FIG. 9. GAN based network architecture

pixel shuffler up scale the temporal frames to reconstruct the input feature (Chen et al., 2020).

The generator and discriminator are trained using three kinds of loss functions: (1) Least square GAN loss, (2) Huber loss and (3) cross entropy loss. The least square GAN and Huber loss are used here to stabilize the training and for better contextual reconstruction (Chen et al., 2020). The cross entropy loss is used to condition the network to learn the class specific information. The discriminator provides two kinds of outputs, one belongs to real/fake detection and the other belongs to classification. The parameters of the discriminator are updated using the sum of both least square GAN loss and cross entropy loss. Similarly, the parameters of the generator are updated using the sum of all three loss functions. The architecture of both the generator and discriminator along with their layer wise input output flow, have been depicted in Fig. 9. During training, the network is trained for 1300 epochs with Adam optimizer. The learning rate of 0.0002 is used for both generator and discriminator training. For improving the stability, label smoothing is employed to the ground truth labels of real/fake samples (Chen et al., 2020). The real and fake sample's label is replaced with random numbers between 0.7 – 1 and 0 – 0.3, respectively. After training using the loss and accuracy of training and validation, the model parameters belonging to the 1167th epoch are chosen for the further study. After training, the generator is detached from the network, and the discriminator is used for further analysis. For dst measure, the test utterances are passed through the discriminator with each frame shift having a context of 48 frames. The linear output has been taken from the classifier node of the discriminator and used to generate dst_t and dst_f as like earlier sections. The obtained linear output is depicted in Fig. 10(c). Similarly the discriminator's softmax output of the classification node has been used to generate the ldv_t and ldv_f distribution for different neighborhood duration (i.e NVF-

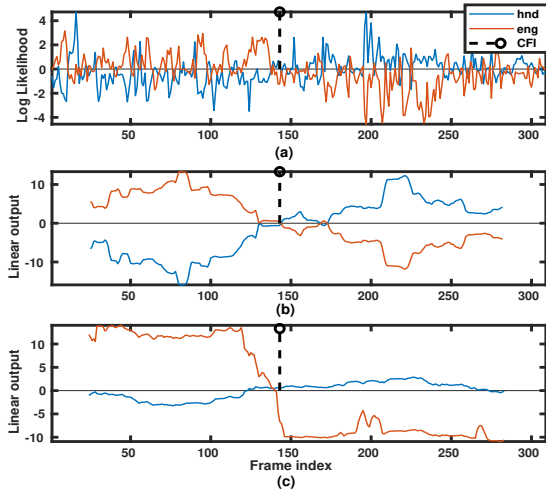

FIG. 10. Obtained output contour of an utterance, (a) GMM-UBM, (b) Attention, (c) GAN.

x). The obtained true and false distribution for both the measures along with their corresponding CD values are shown in Fig. 11(c),(d) and Fig. 12(c),(d), respectively.

The figure shows, irrespective of the analysis group and measures, the CD values are higher for GAN based models. From the box plots of true and false distribution, it can be clearly observed that, as compared to GMM and attention model, the positive separation between true and false distribution is higher in case of GAN model. Therefore the use of generative strategy helps to better capture the language specific information. At the same time the CD value increases with increase in neighborhood duration around change point ensures better change point locating ability of the model. Further from Fig. 10(b) and (c), the output contours show the significance of generative strategy to locate the language change point as compared to the attention based discriminative strategy.

V. EXPERIMENTAL RESULTS AND DISCUSSION

This section provides a description of the conducted LCD and SCD experiments. Followed by this, the results will be interpreted and discussed.

A. Database details

To perform the LCD task, manually annotated a subset of MUCS2021 Hindi-English dataset (SMUCS-HE) and Microsoft code-switched challenge task-B dataset (MSCSTB) (Diwan *et al.*, 2021). As the study consists of both unsupervised and supervised approaches to perform LCD tasks, the dataset is divided into training and testing sets. For SMUCS-HE 70% and 30% of random split has been used to generate training and testing sets. Similarly, MSCSTB dataset consist of training and development data partitions of Gujarati-English (GU),

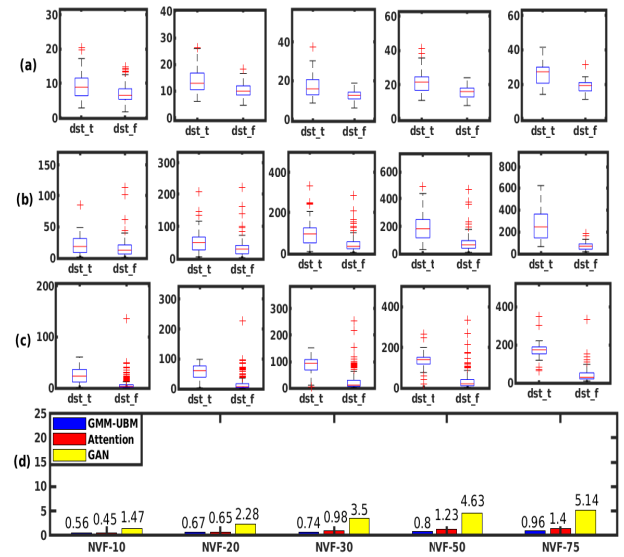

FIG. 11. Distance distribution around true and false change point, (a) GMM-UBM, (b) Attention, (c) GAN, and (d) CD values.

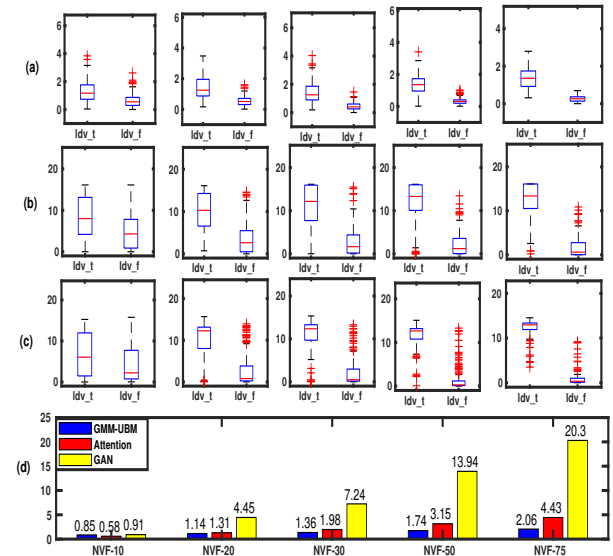

FIG. 12. Distribution of likelihood deviation around true and false change point, (a) GMM-UBM, (b) Attention, (c) GAN, and (d) CD values

Tamil-English (TAE) and Telugu-English (TEE) code-switched utterances. Similarly, to perform the SCD task, a subset of utterances from the IITG-MV-P3 dataset is used (Haris *et al.*, 2012). As each code-switched utterance is spoken by a single speaker, the occurrence of an overlapped segment is highly unlikely. Therefore, the standard speaker diarization (SD) dataset like DIHARD, AML, cannot be used in this study, as the dataset con-

sists of overlapped speaker segments around the change point. Selected subset of IITG-MV phase 3 (SIITG-MV-P3) data consists of two session recordings of approximately 10 – 15 minutes conversation of 4 speaker pairs. During conversation, there exist a total 659 number of speaker change points.

B. Experimental setup for LCD and SCD task

Inspired from the literature of SCD task, initially both LCD and SCD tasks are performed using an unsupervised symmetric KL divergence based approach. After that Model based approaches, namely, (1) GMM-UBM, (2) attention, and (3) GAN are used. All the studies use 39 dimensional MFCC- $\Delta - \Delta\Delta$ features. The Features are extracted from the voiced frames and have frame size and frame shift of 20 msec and 10 msec, respectively. To decide upon the voiced frame, average short time energy based threshold is used, whereas for MSCSTB dataset ground truth labels for the non silence frames are used.

The training set is reserved for the training of supervised models. Though the unsupervised approach does not require training data, to show fair comparison, only the test set of the database is used to perform the LCD and SCD tasks. Using the predicted and ground truth change point information, a performance measure that is generally used for event detection tasks is used here (Murty and Yegnanarayana, 2008). The performance measures Identification rate (IDR), false acceptance rate (FAR), miss rate (MR) and identification accuracy (IDA) are used to calibrate the system performance.

In case of model based approaches, the procedure that was followed in our previous work (Mishra *et al.*, 2021) is used here to predict the change points from the output contour. A Gaussian smoothing with appropriate optimal window duration is used to smooth the output contour of the given test utterance. After that the smoothed contour is used to predict the change point.

1. Unsupervised distance based approach

As mentioned in (Moattar and Homayounpour, 2012; Park *et al.*, 2022; Tranter and Reynolds, 2006), similar framework is used here to derive the evidence contour for both LCD and SCD tasks. For a fixed duration of analysis window, the feature vectors from the two consecutive analysis windows are modeled using two different GMMs (g_i and g_j), and the divergence distance (D) between the two Gaussian is computed using Eq. 5, where i and j are the analysis window index, ranging from $1 \leq i \leq L - 1$ and $2 \leq j \leq L$ and L is the number of possible analysis window for an utterance.

$$D(i, j) = KL(g_i|g_j) + KL(g_j|g_i), \quad (5)$$

The entire scan of a test utterance through the consecutive analysis window will provide a distance based evidence contour (D). A peak picking algorithm (from MATLAB) is used on the distance contour to find out

TABLE I. Performance of SLD and LCD task using KL divergence based approach. NOC: number of GMM clusters.

Task	Database	NOC	IDR	MR	FAR	IDA
LCD	SMUCS-HE	1	33.7	0	66.3	0.292
	MSCSTB-GE	1	33.96	9.49	56.55	0.175
	MSCSTB-TAE	1	29.89	7.81	62.3	0.174
	MSCSTB-TEE	1	31.73	9.0	59.2	0.177
SCD	SIITG-MV-P3	4	45.21	22.20	32.54	0.499

the peaks and corresponding locations. For reducing the false change points a threshold contour is derived from the distance contour using Eq. 6, where N is the number of previous successive distances used for predicting the threshold and α is the amplification factor set to 1 for this study (Lu and Zhang, 2002).

$$Th(i) = \alpha \cdot \frac{1}{N} \sum_{n=0}^N D(i-n-1, i-n) \quad (6)$$

After that, the detected peaks and the threshold contour are compared for predicting the language / speaker change points. For LCD task, the performance is computed in both SMUCS-HE and MSCSTB datasets. The obtained optimal analysis window and hop length for SMUCS-HE is 120 and 10, and for MSCSTB is 70 and 10 frames, respectively. Similarly, For SCD task, the performance is optimized with different analysis window and hop length. The obtained optimal analysis window and hop length is 120 and 10 frames, respectively. The performance for both LCD and SCD task are reported in Table I.

From Table I, it can be observed that the performance of SCD task is better than the performance of LCD task. As discussed in section III, the unsupervised approach fails to appropriately detect the language change points due to the unavailability of short term spectro-temporal cues. This suggests the requirement of higher level of information for capturing language specific phonemic variation, to appropriately detect the language change points.

2. GMM-UBM based approach

The UBM model is trained for each language pair, using the training set. The ground truth labels are used to separate the frames belonging to L1 (Hindi/Gujarati/Tamil/Telugu) language and L2 (English). The MFCC feature vectors belonging to the separated L1 and L2 frames are used to train the adaptation models. To decide on the optimal cluster size of the GMM model, a language identification (LID) task is performed. The MFCC features belonging to both L1 and L2 frames of each test utterance are extracted using their ground truth label. Utterance wise all the frames belonging to L1 and L2 are concatenated to form L1-segment

and L2-segment respectively. The L1-segments and L2-segments are used for LID testing. For SMUCS-HE dataset, 256 cluster size is found to be optimal, whereas for MSCSTB dataset, cluster size of 1024, 512 and 1024 is found to be optimal for GU, TAE and TEE language pairs, respectively. The UBM and adapted models with optimal clusters are used to extract the likelihood contour for each test utterance. The likelihood contour of each test utterance is used as output contour to predict the change points. The predicted change points are then compared with the ground truth change points and are tabulated in Table II.

3. Attention based approach

As mentioned in section IV B, the same architecture and procedures has been used here to train the attention based neural network. In the MSCSTB dataset, the extracted L1 and L2 feature vectors are highly imbalanced (i.e. 80 – 20%). Hence to avoid overfitting towards a single class, a weighted cross-entropy loss and a dropout of 0.2 have been used in layer 2, 3, 4 and 7. Other training parameters are kept the same as mentioned in section IV B. In the MSCSTB dataset, each pair of languages (i.e GE, TAE and TEE) are used to separately train each model for 100 epochs. The l1-segment and l2-segment of each utterance is used as a development set. During training, along with validation loss, language identification error is computed with each epoch. After training, the optimal model is selected by comparing both the validation loss and language identification error. For the GE language pair, out of 100 models, the model belonging to the 7th epoch is selected. Similarly, for TAE and TEE language pairs, the model belonging to 8th and 9th epoch is selected for language change study. The test utterances are passed through the network and the linear output from the output node is extracted and used as output contour. The output contour of each utterance is used to predict the language change points. The ground truth and predicted change points are compared and are tabulated in Table II.

4. GAN based approach

The same architecture and training procedure as mentioned in section IV C is used here to train the network. For MSCSTB dataset, as the training data is highly imbalanced, to avoid overfitting, weighted cross entropy loss and with dropout of 0.2 for layer 2, 3, 4 and 7 is used to train the discriminator. To train the generator of GAN, for stabilizing the training, initially the generator is warmed up with Huber loss for 50 epochs. After that the generator and discriminator have been simultaneously trained for 100 epochs. The optimal model is selected by observing both the validation loss and language identification error. For the GE language pair, out of 100 models, the discriminator model belonging to 8th epoch is selected for language change study. Similarly, for TAE and TEE language pairs, the discriminator models belonging to 49th and 48th epoch have been

TABLE II. Performance of SLCD task using GMM-UBM based approach, Win-dur: in number of frames, M1: GMM-UBM, M2: Attention and M3: GAN.

Database	Model	Win-dur	IDR	MR	FAR	IDA
SMUCS-HE	M1	73	87.9	0	12.1	0.093
	M2	59	89.5	2.1	8.4	0.161
	M3	69	92.6	0	7.37	0.103
MSCSTB-GE	M1	80	39.70	32.8	27.7	0.269
	M2	119	46.23	38.94	14.83	0.360
	M3	113	48.05	36.45	15.50	0.364
MSCSTB-TAE	M2	100	33.60	44.24	22.16	0.286
	M2	133	48.03	36.0	15.97	0.402
	M3	139	48.71	36.75	14.54	0.398
MSCSTB-TEE	M2	95	40.77	37.8	21.43	0.294
	M2	125	46.57	37.83	15.59	0.396
	M3	141	47.38	40.38	12.24	0.404

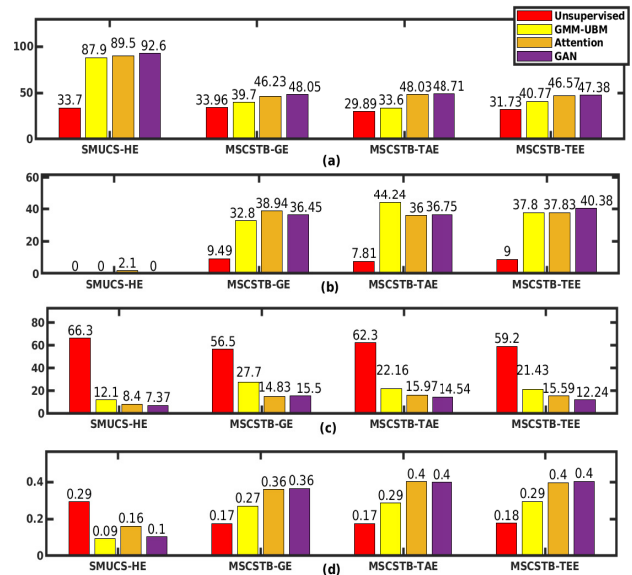

FIG. 13. Performance comparison with model based approaches for SLCD task (a): IDR, (b): MR, (c): FAR, (d): IDA

selected for language change study. For each test utterance, the output contour is extracted from the linear output layer of the discriminator, and then used to predict the language change points. After that, the predicted and ground truth change points are compared and the performance is tabulated in Table II

C. Discussion

The experimental results are tabulated in Table II and depicted in Fig. 13. From the Table and Fig. 13(a-

TABLE III. Performance in terms of frame error rate (FER)

Database	GMM-UBM	Attention	GAN
SMUCS-HE	25.6	8.4	6.8
MSCSTB-GE	39.7	38.72	36.45
MSCSTB-TAE	42.38	38.61	33.46
MSCSTB-TEE	41.39	39.2	32.31

c), it can be observed that incorporating more and more evidence that human use for language discrimination to the computational model, the IDR value increases by decreasing the MR and FAR values, irrespective of the database. We can also observe that, for SMUCS-HE dataset, there exist a significant improvement (i.e. from 33.7% to 87.9%) in the IDR value. This shows the effectiveness incorporating prior language specific knowledge in terms of GMM-UBM model. After that incorporating temporal learning strategy in terms of attention, a farther level of improvement has been achieved (i.e. from 87.9% to 89.5%). As like human, the generative patterns have been stored and during language change, the same information is used to detect the change. Invoking the same, GAN strategy has been used, where the generator helps to the discriminator to better learn the language specific temporal evidence. From the figure it can also be observed that, incorporating GAN strategy the performance in terms IDR increase from 89.5% to 92.6%.

For MSCSTB dataset, though there exists a trend of performance improvement, as per our initial hypothesis, but the achieved performance is faraway from the performance achieved in SMUCS-HE dataset. This is happening may be due to two reasons: (1) unbalanced train data, (2) window based smoothing approach. The SMUCS-HE dataset is manually annotated and the selected segment used for this study has approximately equal number of syllables on either side of the change point. This may be the reason for achieving expected results in the SMUCS-HE dataset, whereas MSCSTB is a more practical dataset. The MSCSTB dataset has approximately 80% frames belonging to L1 language and the rest 20% to L2 language. This poses a challenge towards training of neural network models. Though we have used weighted loss and drop out to avoid overfitting towards L1 language class, still the problem persists. This can be better understood from the tabulated LID performance in terms of frame error rate.

From Table III, it can be observed that there exists a significant reduction in FER values (i.e. from 25.6% to 8.6%) from GMM-UBM approach to attention approach. Whereas in all three language pairs of MSCSTB dataset, fails to achieve the same amount of reduction in FER value. For a practical code-switching data, data imbalance seems to be a challenge to train the supervised models. Thus in our future exploration we will try to resolve this issue.

Similarly, the language change point prediction depends on the window length parameter. Whereas there is no constraint on the monolingual segment duration of a code-switched utterance. The depicted performances are for the optimal window length. The optimal window length is chosen greedily, by varying the window duration from 3 to 150 frames. For model based approaches, irrespective of the dataset and approach, the optimal window duration is more than 80 leads to smoothing the output contour. Thus the small monolingual segment (which are less than 80 voiced frames) switching has been missed during change point prediction. This we can observe in the Fig. 13(b). This shows, though there exists an improvement in IDR, the MR has not been reduced comparatively. Mostly the improvement in IDR is due to the reduction of FAR values (Fig 13(c)). Also due to the high value of window duration, the detected change point will occur with a high delay with respect to the ground truth change point). From Fig 13(d) it can be observed that the IDA values increase with increase in optimal window duration. In the future, our aim is to explore the change point detection approach, which is independent of window duration.

VI. CONCLUSION

In this work, we performed a comparative analysis on speaker and language change detection. From the subjective study it has been observed that humans require comparatively larger neighborhood information around the change point to detect language than speaker. From the objective study, it has been observed that it is difficult to locate the language change even after considering approximately 2.25 seconds of information around the change point, using an unsupervised distance based approach. After that the model based approaches namely, GMM-UBM, attention and GAN based approach have been explored. It is observed that using supervised model based approaches, it is feasible to locate the language change. Also, the performance of LCD task improves by including temporal information through attention based framework and capturing language specific generative information through GAN framework.

In future, we plan to explore and resolve the issues related to relatively low performance in case of practical dataset, by coming up with alternative strategies to train the supervised model with unbalanced data. Also alternative approaches to predict change points which are independent of window duration.

¹Supplementary materials for the data generation of language and speaker change detection by human at [URL will be inserted by AIP]

Ambikairajah, E., Li, H., Wang, L., Yin, B., and Sethu, V. (2011). "Language identification: A tutorial," *IEEE Circuits and Systems Magazine* 11(2), 82–108.

Chan, J. Y., Ching, P., Lee, T., and Meng, H. M. (2004). "Detection of language boundary in code-switching utterances by bi-phone probabilities," in *2004 International Symposium on Chi-*

- nese Spoken Language Processing, IEEE, pp. 293–296.
- Chen, L., Liu, Y., Xiao, W., Wang, Y., and Xie, H. (2020). “Speaker identification with conditional generative adversarial network,” *Neurocomputing* **418**, 211–220.
- Chen, S., Gopalakrishnan, P. *et al.* (1998). “Speaker, environment and channel change detection and clustering via the bayesian information criterion,” in *Proc. DARPA broadcast news transcription and understanding workshop*, Virginia, USA, Vol. 8, pp. 127–132.
- Cruttenden, A. (2014). *Gimson’s Pronunciation of English* (Taylor & Francis), <https://books.google.co.in/books?id=M2nMAGAAQBAJ>.
- Dawalatabad, N., Madikeri, S., Sekhar, C. C., and Murthy, H. A. (2020). “Novel architectures for unsupervised information bottleneck based speaker diarization of meetings,” *IEEE/ACM Transactions on Audio, Speech, and Language Processing* **29**, 14–27.
- Diwan, A., Vaideeswaran, R., Shah, S., Singh, A., Raghavan, S., Khare, S., Unni, V., Vyas, S., Rajpuria, A., Yarra, C., Mittal, A., Ghosh, P. K., Jyothi, P., Bali, K., Seshadri, V., Sitaram, S., Bharadwaj, S., Nanavati, J., Nanavati, R., Sankaranarayanan, K., Seeram, T., and Abraham, B. (2021). “Multilingual and code-switching asr challenges for low resource indian languages,” *Proceedings of Interspeech* .
- Gish, H., Siu, M.-H., and Rohlicek, J. R. (1991). “Segregation of speakers for speech recognition and speaker identification,” in *icassp*, Vol. 91, pp. 873–876.
- Goodfellow, I. (2016). “Nips 2016 tutorial: Generative adversarial networks,” arXiv preprint arXiv:1701.00160 .
- Haris, B. C., Pradhan, G., Misra, A., Prasanna, S., Das, R. K., and Sinha, R. (2012). “Multivariability speaker recognition database in indian scenario,” *International Journal of Speech Technology* **15**(4), 441–453.
- Hart, P. E., Stork, D. G., and Duda, R. O. (2000). *Pattern classification* (Wiley Hoboken).
- Li, H., Ma, B., and Lee, K. A. (2013). “Spoken language recognition: from fundamentals to practice,” *Proceedings of the IEEE* **101**(5), 1136–1159.
- Liu, H., Perera, L. P. G., Zhang, X., Dauwels, J., Khong, A. W., Khudanpur, S., and Styles, S. J. (2021). “End-to-end language diarization for bilingual code-switching speech,” in *22nd Annual Conference of the International Speech Communication Association, INTERSPEECH 2021*, International Speech Communication Association, Vol. 2.
- Lu, L., and Zhang, H.-J. (2002). “Speaker change detection and tracking in real-time news broadcasting analysis,” in *Proceedings of the tenth ACM international conference on Multimedia*, pp. 602–610.
- Lyu, D. C., Chng, E. S., and Li, H. (2013). “Language diarization for conversational code-switch speech with pronunciation dictionary adaptation,” in *Signal and Information Processing (ChinaSIP), 2013 IEEE China Summit and International Conference on*, IEEE, pp. 147–150.
- Mishra, J., Agarwal, A., and Prasanna, S. M. (2021). “Spoken language diarization using an attention based neural network,” in *2021 National Conference on Communications (NCC)*, IEEE, pp. 1–6.
- Moattar, M. H., and Homayounpour, M. M. (2012). “A review on speaker diarization systems and approaches,” *Speech Communication* **54**(10), 1065–1103.
- Murty, K. S. R., and Yegnanarayana, B. (2008). “Epoch extraction from speech signals,” *IEEE Transactions on Audio, Speech, and Language Processing* **16**(8), 1602–1613.
- Park, T. J., Kanda, N., Dimitriadis, D., Han, K. J., Watanabe, S., and Narayanan, S. (2022). “A review of speaker diarization: Recent advances with deep learning,” *Computer Speech & Language* **72**, 101317.
- Rabiner, L. R. (1978). *Digital processing of speech signals* (Pearson Education India).
- Raffel, C., and Ellis, D. P. (2015). “Feed-forward networks with attention can solve some long-term memory problems,” arXiv preprint arXiv:1512.08756 .
- Reynolds, D. A. (1995). “Speaker identification and verification using gaussian mixture speaker models,” *Speech communication* **17**(1-2), 91–108.
- Richardson, F., Reynolds, D., and Dehak, N. (2015). “Deep neural network approaches to speaker and language recognition,” *IEEE signal processing letters* **22**(10), 1671–1675.
- Ryant, N., Church, K., Cieri, C., Cristia, A., Du, J., Ganapathy, S., and Liberman, M. (2018). “First dihard challenge evaluation plan,” 2018, tech. Rep. .
- Sharma, N. K., Ganesh, S., Ganapathy, S., and Holt, L. L. (2019). “Talker change detection: A comparison of human and machine performance,” *The Journal of the Acoustical Society of America* **145**(1), 131–142.
- Shen, P., Lu, X., Li, S., and Kawai, H. (2017). “Conditional generative adversarial nets classifier for spoken language identification,” in *Interspeech*, pp. 2814–2818.
- Siddhartha, S., Mishra, J., and Prasanna, S. R. M. (2020). “Language specific information from LP residual signal using linear sub band filters,” in *2020 National Conference on Communications (NCC)*, IEEE, pp. 1–5.
- Siegler, M. A., Jain, U., Raj, B., and Stern, R. M. (1997). “Automatic segmentation, classification and clustering of broadcast news audio,” in *Proc. DARPA speech recognition workshop*, Vol. 1997.
- Sitaram, S., Chandu, K. R., Rallabandi, S. K., and Black, A. W. (2019). “A survey of code switching speech and language processing,” arXiv:1904.00784 [cs.CL] .
- Snyder, D., Garcia-Romero, D., McCree, A., Sell, G., Povey, D., and Khudanpur, S. (2018). “Spoken language recognition using x-vectors,” in *Odyssey*, pp. 105–111.
- Spoorthy, V., Thenkanidiyoor, V., and Dinesh, D. A. (2018). “SVM Based Language Diarization for Code-Switched Bilingual Indian Speech Using Bottleneck Features,” in *Proc. The 6th Intl. Workshop on Spoken Language Technologies for Under-Resourced Languages*, pp. 132–136, <http://dx.doi.org/10.21437/SLTU.2018-28>, doi: 10.21437/SLTU.2018-28.
- Tranter, S. E., and Reynolds, D. A. (2006). “An overview of automatic speaker diarization systems,” *IEEE Transactions on audio, speech, and language processing* **14**(5), 1557–1565.
- Wong, E., and Sridharan, S. (2002). “Methods to improve gaussian mixture model based language identification system,” in *Seventh International Conference on Spoken Language Processing*.
- Zhang, H. J. (2013). “Code-switching speech detection method by combination of language and acoustic information,” in *Advanced Materials Research*, Trans Tech Publ, Vol. 756, pp. 3622–3627.