

Quantum secure non-malleable-codes in the split-state model

Naresh Goud Boddu* Rahul Jain †

Abstract

Non-malleable-codes introduced by Dziembowski, Pietrzak and Wichs [DPW18] encode a classical message S in a manner such that tampering the codeword results in the decoder either outputting the original message S or a message that is unrelated/independent of S . Providing such non-malleable security for various tampering function families has received significant attention in the recent years. We consider the well studied (2-part) *split-state* model, in which the message S is encoded into two parts X and Y , and the adversary is allowed to arbitrarily tamper with each X and Y individually. Non-malleable-codes in the split-state model have found applications in other important security notions like *non-malleable commitments* and *non-malleable secret sharing*. Thus, it is vital to understand if such non-malleable-codes are secure against quantum adversaries.

We consider the security of non-malleable-codes in the split-state model when the adversary is allowed to make use of arbitrary entanglement to tamper the parts X and Y . We construct explicit quantum secure non-malleable-codes in the split-state model. Our construction of quantum secure non-malleable-codes is based on the recent construction of quantum secure 2-source *non-malleable-extractors* by Boddu, Jain and Kapshikar [BJK21].

- We extend the connection of Cheraghchi and Guruswami [CG16] between 2-source non-malleable-extractors and non-malleable-codes in the split-state model in the classical setting to the quantum setting, i.e. we show that explicit quantum secure 2-source non-malleable-extractors in (k_1, k_2) -qma-state framework of [BJK21] give rise to explicit quantum secure non-malleable-codes in the split-state model.
- We construct the first explicit quantum secure non-malleable-code for message length $m = n^{\Omega(1)}$, error $\varepsilon = 2^{-n^{\Omega(1)}}$ and codeword of size $2n$. Prior to this work, it remained open to provide such quantum secure non-malleable-code even for a single bit message in the split-state model.
- We also study its natural extension when the tampering of the codeword is performed t -times. We construct explicit quantum secure t -non-malleable-code for $t = n^{\Omega(1)}$, message length $m = n^{\Omega(1)}$, error $\varepsilon = 2^{-n^{\Omega(1)}}$ and codeword of size $2n$.

*Center for Quantum Technologies, National University of Singapore, e0169905@u.nus.edu

†Centre for Quantum Technologies and Department of Computer Science, National University of Singapore and MajuLab, UMI 3654, Singapore, rahul@comp.nus.edu.sg

1 Introduction

In a seminal work, Dziembowski, Pietrzak and Wichs [DPW18] introduced non-malleable-codes to provide a meaningful guarantee for the encoded message S in situations where traditional error-correction or even error-detection is impossible. Informally, non-malleable-codes encode a classical message S in a manner such that tampering the codeword results in decoder either outputting the original message S or a message that is unrelated/independent of S . Using probabilistic arguments [DPW18] showed the existence of such non-malleable-codes against a broad family of tampering functions \mathcal{F} as large as $2^{2^{\alpha n}}$ for any fixed constant $\alpha < 1$, where n is the length of codeword for messages of length $\Omega(n)$.

Subsequent works continued to study non-malleable-codes in various tampering models. Perhaps the most well known of these tampering function families is the so called split-state model introduced by Liu and Lysyanskaya [LL12], who constructed efficient constant rate non-malleable-codes against computationally bounded adversaries under strong cryptographic assumptions. We refer to the (2-part) split-state model as the split-state model in this paper. In the split-state model, the message S is encoded into two parts, X and Y , after which the adversary is allowed to arbitrarily tamper $(X, Y) \rightarrow (X', Y')$ such that $(X', Y') = (f(X), g(Y))$ for any functions (f, g) such that $f, g : \{0, 1\}^n \rightarrow \{0, 1\}^n$. Dziembowski, Kazana and Obremski [DKO13] proposed a construction that provides non-malleable-codes for a single bit message based on strong extractors. Subsequently, multiple works considered non-malleable-codes for multi-bit messages leading to constant rate non-malleable-codes in the split-state model [ADL18, CGL20, AO20, LL12, CG16, CG14, Agg15, Li17, Li19, Li15]. Non-malleable-codes in the split-state model have found applications to numerous other important security notions such as non-malleable commitments and non-malleable secret sharing [GPR16, GK18a, GK18b, ADN⁺19, SV19].

Let n, m represent positive integers and $k, \varepsilon, \varepsilon' > 0$ represent reals. Let \mathcal{F} denote the set of all functions $f : \{0, 1\}^n \rightarrow \{0, 1\}^n$. We consider the standard encoding and decoding schemes in the split-state model as stated below.

Definition 1 (Standard encoding and decoding scheme in the split-state model). *Let $\text{Enc} : \{0, 1\}^m \rightarrow \{0, 1\}^n \times \{0, 1\}^n$ be a randomized function ¹ and $\text{Dec} : \{0, 1\}^n \times \{0, 1\}^n \rightarrow \{0, 1\}^m \cup \{\text{same}\}$ be a deterministic function. We say (Enc, Dec) is a standard encoding and decoding scheme in the split-state model if the following holds: for all messages $s \in \{0, 1\}^m$,*

$$\Pr(\text{Dec}(\text{Enc}(s)) = s) = 1.$$

The probability above is over the internal randomness used in encoding. We define the function $\text{copy} : \{0, 1\}^* \times \{0, 1\}^* \rightarrow \{0, 1\}^*$. $\text{copy}(x, s) = s$ if $x = \text{same}$, otherwise $\text{copy}(x, s) = x$. We next define the non-malleable-codes in the split-state model in the classical setting.

Definition 2 (non-malleable-codes in the split-state model [LL12, DPW18]). *A standard encoding and decoding scheme (Enc, Dec) (see Definition 1) with message length m and block length n is an (m, n, ε) -non-malleable-code with respect to a family of tampering functions $\mathcal{F} \times \mathcal{F}$, if for every $f = (g_1, g_2) \in \mathcal{F} \times \mathcal{F}$, there exists a random variable $\mathcal{D}_f = \mathcal{D}_{(g_1, g_2)}$ on $\{0, 1\}^m \cup \{\text{same}\}$ which is independent of the randomness in Enc such that for all messages $s \in \{0, 1\}^m$, it holds that*

$$\|\text{Dec}(f(\text{Enc}(s))) - \text{copy}(\mathcal{D}_f, s)\|_1 \leq \varepsilon.$$

¹Randomized function is a function chosen randomly using internal randomness.

Previous classical results in the split-state model

[DKO13] constructed the first non-malleable-code for a 1-bit message. Following that [ADL18] gave the first information-theoretic construction for m -bit messages, but the length of codeword being $2n = m^{\mathcal{O}(1)}$. [CGL20] gave a non-malleable-code for message length $m = n^{\Omega(1)}$, error $\varepsilon = 2^{-n^{\Omega(1)}}$ and codeword of size $2n$. Improving upon the work of [CGL20], [Li19] gave a non-malleable-code for message length $m = \mathcal{O}\left(\frac{n \log \log n}{\log n}\right)$, error $\varepsilon = 2^{-n^{\Omega(1)}}$ and codeword of size $2n$. Only recently [AO20] gave the first constant rate non-malleable-code for message length $m = \Omega(n)$, error $\varepsilon = 2^{-n^{\Omega(1)}}$ and codeword of size $2n$.

Our work provides the first explicit quantum secure non-malleable-code for message length $m = n^{\Omega(1)}$, error $\varepsilon = 2^{-n^{\Omega(1)}}$ and codeword of size $2n$. When the tampering of the codeword is performed t -times, we also provide the first explicit quantum secure t -non-malleable-code for $t = n^{\Omega(1)}$, message length $m = n^{\Omega(1)}$, error $\varepsilon = 2^{-n^{\Omega(1)}}$ and codeword of size $2n$. Prior to our work, it remained open to provide such quantum secure non-malleable-codes even for a single bit message in the split-state model.

Motivation to consider the quantum setting

With the rise of quantum computers, it becomes vital to understand if non-malleable-codes are secure against quantum adversaries. Quantum entanglement between various parties, used to generate classical information introduces *non-local correlations* [Bel64]. For example in the CSHS game, one can use local measurements on both the halves of a EPR state to generate a probability distribution which contains correlations stronger than those possible classically. Entanglement is of course known to yield several such unexpected effects with no classical counterparts, e.g., *superdense coding* [BW92]. Thus, it motivates us to consider if one can provide non-malleable-codes when adversary in the split-state model is allowed to make use of an arbitrary entanglement (between the two parts) to tamper the two parts X and Y (both classical) of an encoded message S . We note to the reader that the (Enc, Dec) schemes considered in this paper are classical, and we provide quantum security in the sense that the adversary is allowed to do quantum operations to tamper $(X, Y) \rightarrow (X', Y')$ using pre-shared unbounded entanglement.

Our results

Our first contribution is setting up the required analogue/framework to define non-malleable-codes in the quantum setting.

Quantum split-state adversary

Let classical message S be encoded into two classical registers X, Y that are stored at two different locations. To tamper $(X, Y) \rightarrow (X', Y')$, we let the adversary share an arbitrary entanglement ψ_{NM} ² between the two different locations where split codewords are stored. The adversary then applies isometries $U : \mathcal{H}_X \otimes \mathcal{H}_N \rightarrow \mathcal{H}_{X'} \otimes \mathcal{H}_{N'}$ and $V : \mathcal{H}_Y \otimes \mathcal{H}_M \rightarrow \mathcal{H}_{Y'} \otimes \mathcal{H}_{M'}$ to tamper³ $(X, Y) \rightarrow (X', Y')$. The decoding process begins by first measuring (X', Y') and then outputting

²Without any loss of generality, one can consider ψ as a pure state.

³This is without any loss of generality since one can consider Strinespring isometry extension of a CPTP map Φ as isometry if the tampering is given by a CPTP map Φ .

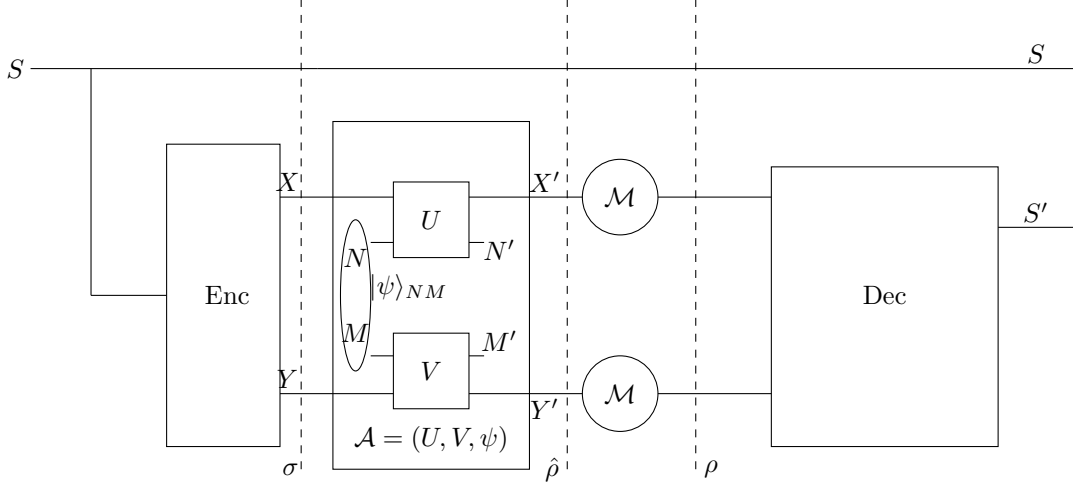

Figure 1: Quantum split-state adversary along with the process.

the decoded message S' from (X', Y') (post measurement in the computational basis). To show that non-malleable-codes are secure against such an adversary, we need to show that the decoded message S' is unrelated to the encoded message S . We show it via the simulation argument, in which if the adversary tampers the codeword, the decoded message can be simulated by a distribution $\mathcal{D}_{(U,V,\psi)}$ that only depends on (U, V, ψ) , and thus, unrelated to message S . For simplicity, we denote quantum split-state adversary as $\mathcal{A} = (U, V, \psi)$ in this paper.

We now formally define quantum split-state adversary in the split-state model.

Definition 3 (Quantum split-state adversary (see Figure 1)). *Let message $S = U_m$ ⁴, (Enc, Dec) be a standard encoding and decoding scheme in the split-state model (see Definition 1) and $(X, Y) = \text{Enc}(S)$. Let σ_{SXY} be the state after encoding message S . The quantum split-state adversary (denoted $\mathcal{A} = (U, V, \psi)$) will act via two isometries, (U, V) using an additional shared entangled state $|\psi\rangle_{NM}$ as specified by $U : \mathcal{H}_X \otimes \mathcal{H}_N \rightarrow \mathcal{H}_{X'} \otimes \mathcal{H}_{N'}$ and $V : \mathcal{H}_Y \otimes \mathcal{H}_M \rightarrow \mathcal{H}_{Y'} \otimes \mathcal{H}_{M'}$. Let $\hat{\rho} = (U \otimes V)(\sigma \otimes |\psi\rangle\langle\psi|)(U \otimes V)^\dagger$ and ρ be the final state after measuring the registers $(X'Y')$ in the computational basis⁵.*

Definition 4 (Quantum secure non-malleable-codes in the split-state model). *A standard encoding and decoding scheme (Enc, Dec) (see Definition 1) with message length m and block length n is an (m, n, ε) -quantum secure non-malleable-code in the split-state model with error ε , if for state ρ and adversary $\mathcal{A} = (U, V, \psi)$ (as defined in Definition 3), there exists a random variable $\mathcal{D}_{\mathcal{A}}$ ⁶ on $\{0, 1\}^m \cup \{\text{same}\}$ such that*

$$\|\rho_{SS'} - \text{Zcopy}(\mathcal{D}_{\mathcal{A}}, Z)\|_1 \leq \varepsilon,$$

⁴ U_m is the uniform distribution on m bits.

⁵We enforce the quantum split-state adversary to return classical registers X', Y' by doing the measurement in the computational basis. This is without any loss of generality since the decoding process can start by doing the measurement (this will not affect anything in the absence of quantum split-state adversary) and then decode using Dec.

⁶Distribution depends only on \mathcal{A} .

where $Z = U_m$.

Note that the Definition 4 is defined for uniform message S whereas the standard classical definition (see Definition 2) is defined for all $s \in S$. But one can go from average case setting ε (for uniform message S) to the worst case setting ε' (for every message s) using Fact 5 (see Section 2) with $\varepsilon' = 2^m \varepsilon$. Since we construct non-malleable-codes for $\varepsilon = 2^{-n^{\Omega(1)}}$ (for uniform message S), we get non-malleable-codes that work for the worst case setting (for every message s) as long as $m = n^{\Omega(1)}$.

We next state a result regarding the existence of quantum secure non-malleable-codes in the split-state model based on quantum secure 2-source non-malleable-extractors (see Definition 11).

Theorem 1 (Quantum secure non-malleable-codes in the split-state model). *Let $2\text{nmExt} : \{0, 1\}^n \times \{0, 1\}^n \rightarrow \{0, 1\}^m$ be an $(n - k, n - k, \varepsilon)$ -quantum secure 2-source non-malleable-extractor. There exists an (m, n, ε') -quantum secure non-malleable-code in the split-state model with parameter $\varepsilon' = 4(2^{-k} + \varepsilon) + \varepsilon$.*

We also construct an explicit quantum secure non-malleable-code in the split-state model. Our construction of quantum secure non-malleable-code is based on the recent construction of quantum secure 2-source non-malleable-extractor from [BJK21], which is further based on the classical alternating extraction [CGL20, Coh15] extended to the quantum setting.

Theorem 2. *There exists an (m, n, ε) -quantum secure non-malleable-code in the split-state model with efficient encoding and decoding procedures for message length $m = n^{\Omega(1)}$, error $\varepsilon = 2^{-n^{\Omega(1)}}$ and codeword of size $2n$.*

Prior to this work, it remained open to provide such construction for quantum secure non-malleable-codes, even for a single bit message in the split-state model.

We also study the natural extension when the tampering of the codeword is performed t -times (see Appendix A).

Theorem 3 (Quantum secure one-many non-malleable-codes in the split-state model). *Let $t\text{-}2\text{nmExt} : \{0, 1\}^n \times \{0, 1\}^n \rightarrow \{0, 1\}^m$ be a $(t; n - k, n - k, \varepsilon)$ -quantum secure 2-source t -non-malleable-extractor. There exists a $(t; m, n, \varepsilon')$ -quantum secure one-many non-malleable-code with parameter $\varepsilon' = 2^{2t}(2^{-k} + \varepsilon) + \varepsilon$.*

Theorem 4. *There exists $(t; m, n, \varepsilon)$ -quantum secure one-many non-malleable-code in the split-state model with efficient encoding and decoding procedures for parameters $t = n^{\Omega(1)}$, $m = n^{\Omega(1)}$, error $\varepsilon = 2^{-n^{\Omega(1)}}$ and codeword of size $2n$.*

Proof overview

Our existential proof for non-malleable-codes is inspired from the connection between 2-source non-malleable-extractors and non-malleable-codes in the split-state model [CG16, CGL20] in the classical setting. We generalize the classical proof using quantum information theoretic techniques and extend it to the recent (k_1, k_2) -qma-state framework of [BJK21]. In other words, explicit quantum secure 2-source non-malleable-extractors give rise to explicit quantum secure non-malleable-codes in the split-state model. We then make use of the recent quantum secure 2-source non-malleable-extractor constructions of [BJK21].

Following the classical strategy for the efficient encoding of the non-malleable-code, we modify the quantum secure 2-source non-malleable-extractor from [BJK21]. The modified non-malleable-extractor divides the entire source X, Y into approximately $n^{\Omega(1)}$ blocks each of size $n^{1-\Omega(1)}$. The quantum secure 2-source non-malleable-extractor of [BJK21] is based on the powerful technique of alternating extraction along with *advice generators* and *correlation breakers with advice* [CGL20, Coh16] that uses the *flip-flop* primitive [Coh15]. The idea now is to use new blocks of X and Y for each round of alternating extraction in the construction of non-malleable-extractor. This ensures the linear constraints that are imposed in the alternating extraction are on different variables of input sources, X, Y . Also, since X and Y each have almost full min-entropy, we have block sources, where each block has almost full min-entropy.

We next note that the non-malleable-code from a 2-source non-malleable-extractor (say 2nmExt) of [BJK21] satisfies the property that for a uniform input message, the encoded message (X, Y) is close to uniform distribution over $2n$ -bits. Thus for $\text{Enc}(\cdot) = 2\text{nmExt}^{-1}(\cdot)$, in the analysis we first run $2\text{nmExt}(U_n, U_n)$ to generate intermediate seed random variables and finally output \hat{S} such that $\hat{S} \approx S$. Noting that each and every seeded extractor used in the construction of the modified 2-source non-malleable-extractor of [BJK21] is a strong extractor, we backtrack the generation of intermediate seed random variables for a message $S = U_m$. We show that such a backtracking is possible for strong linear seeded extractors (see Claim 3). Even though, new blocks of sources are used each time in every round of alternating extraction, as we proceed with the backtracking, we immediately face an issue. The issue arises since in the alternating extraction, the intermediate seed random variables (close to uniform) are used as sources to extract additional random variables which are further used to extract from new block of sources. We circumvent the issue by noting that there exists a close by distribution where in each round of alternating extraction, we extract from independent block of sources.

By carefully analyzing the modified non-malleable-extractor construction, we note that we have a well laid Markov-chain between different blocks of sources and intermediate random variables. This allows us to backtrack in steps using a composition argument via Markov-chain formalism (see Claim 2) approximately. One additional technical detail that comes up as the backtracking of intermediate seed random variables for $2\text{nmExt}^{-1}(\hat{S})$ progresses is that it can only be done approximately for each intermediate random variable. We show that the total accumulated error, accounting for this approximation, is still under control until the end. In addition, we use the classical Reed-Solomon code argument (see Lemma 1) from [CGL20] to ensure for any fixing of the advice in the alternating extraction, the constraints imposed on the source are on different variables outside the blocks that are used to extract.

Comparison with the work of [CGL20]

The work of [CGL20] provides an efficient non-malleable-code in the split-state model in the classical setting (when no entanglement is used by the split-state adversary). In other words, they construct 2nmExt such that for any given message $S = s$, sampling from the set $2\text{nmExt}^{-1}(s)$ can be done efficiently. They do so by modifying the seeded extractors used in alternating extraction of earlier 2-source non-malleable-extractors. The desired property of seeded extractors that enables efficient sampling is - for every fixed seed h , the pre-image sizes of all the outputs o of seeded extractor to be exactly same. They construct seeded extractor IExt with the above property. To show the quantum security of non-malleable-extractors constructed using IExt , we need the quantum security of IExt . On the other hand, quantum secure non-malleable-extractors of [BJK21] use Trevison extractor for

which the quantum security is well-established [DPVR12]. We pose showing quantum security of IExt as a future direction. We work with Trevison extractor instead. We use the argument involving the backtracking of the random variables generated in the forward calculation in 2 steps. First, an argument to show that given the output of a strong seeded extractor, one can generate source and seed pair for an approximately independent uniform source and seed in forward calculation. Second, a composition argument via Markov-chain formalism that helps in the backtracking in steps inductively. Overall, we manage to show that encoding for a uniform message S , i.e. $2\text{nmExt}^{-1}(S)$ can be done approximately (for exponentially small error).

Organization

In Section 2, we describe useful quantum information facts and other preliminaries. It also contains useful lemmas and claims. We describe the existential proof of quantum secure non-malleable-codes, i.e. Theorem 1 in Section 3. Section 4 contains the construction of modified 2-source non-malleable-extractor along with proof of Theorem 2. The t -tampered version of non-malleable-codes can be found in the Appendix A.

2 Preliminaries

Let n, m, d, t represent positive integers and $l, k, k_1, k_2, \delta, \gamma, \varepsilon \geq 0$ represent reals.

Quantum information theory

All the logarithms are evaluated to the base 2. Let $\mathcal{X}, \mathcal{Y}, \mathcal{Z}$ be finite sets (we only consider finite sets in this paper). For a *random variable* $X \in \mathcal{X}$, we use X to denote both the random variable and its distribution, whenever it is clear from the context. We use $x \leftarrow X$ to denote x drawn according to X . We also use $x \leftarrow \mathcal{X}$ to denote x drawn uniformly from \mathcal{X} . For two random variables X, Y we use $X \otimes Y$ to denote independent random variables.

We call random variables X, Y , *copies* of each other iff $\Pr[X = Y] = 1$. Let Y^1, Y^2, \dots, Y^t be random variables. We denote the joint random variable $Y^1 Y^2 \dots Y^t$ by $Y^{[t]}$. Similarly for any subset $\mathcal{S} \subseteq [t]$, we use $Y^{\mathcal{S}}$ to denote the joint random variable comprised of all the Y^s such that $s \in \mathcal{S}$. For a random variable $X \in \{0, 1\}^n$ and $0 < d_1 \leq d_2 \leq n$, let $\text{Crop}(X, d_1, d_2)$ represent the bits from d_1 to d_2 of X , i.e. $X^{[d_1, d_2]}$. Let U_d represent the uniform distribution over $\{0, 1\}^d$. For a random variable $X \in \mathbb{F}_q^n$ for a prime power q , we view X as a row vector (X^1, X^2, \dots, X^n) where each $X^i \in \mathbb{F}_q$.

Consider a finite-dimensional Hilbert space \mathcal{H} endowed with an inner-product $\langle \cdot, \cdot \rangle$ (we only consider finite-dimensional Hilbert-spaces). A quantum state (or a density matrix or a state) is a positive semi-definite operator on \mathcal{H} with trace value equal to 1. It is called *pure* iff its rank is 1. Let $|\psi\rangle$ be a unit vector on \mathcal{H} , that is $\langle \psi, \psi \rangle = 1$. With some abuse of notation, we use ψ to represent the state and also the density matrix $|\psi\rangle\langle\psi|$, associated with $|\psi\rangle$. Given a quantum state ρ on \mathcal{H} , *support of ρ* , called $\text{supp}(\rho)$ is the subspace of \mathcal{H} spanned by all eigenvectors of ρ with non-zero eigenvalues.

A *quantum register* A is associated with some Hilbert space \mathcal{H}_A . Define $|A| := \log(\dim(\mathcal{H}_A))$. Let $\mathcal{L}(\mathcal{H}_A)$ represent the set of all linear operators on the Hilbert space \mathcal{H}_A . For operators $O, O' \in \mathcal{L}(\mathcal{H}_A)$, the notation $O \leq O'$ represents the Löwner order, that is, $O' - O$ is a positive semi-definite operator. We denote by $\mathcal{D}(\mathcal{H}_A)$, the set of all quantum states on the Hilbert space \mathcal{H}_A . State ρ

with subscript A indicates $\rho_A \in \mathcal{D}(\mathcal{H}_A)$. If two registers A, B are associated with the same Hilbert space, we shall represent the relation by $A \equiv B$. For two states ρ, σ , we let $\rho \equiv \sigma$ represent that they are identical as states (potentially in different registers). Composition of two registers A and B , denoted AB , is associated with the Hilbert space $\mathcal{H}_A \otimes \mathcal{H}_B$. For two quantum states $\rho \in \mathcal{D}(\mathcal{H}_A)$ and $\sigma \in \mathcal{D}(\mathcal{H}_B)$, $\rho \otimes \sigma \in \mathcal{D}(\mathcal{H}_{AB})$ represents the tensor product (*Kronecker product*) of ρ and σ . The identity operator on \mathcal{H}_A is denoted \mathbb{I}_A . Let U_A denote maximally mixed state in \mathcal{H}_A . Let $\rho_{AB} \in \mathcal{D}(\mathcal{H}_{AB})$. Define

$$\rho_B \stackrel{\text{def}}{=} \text{Tr}_A \rho_{AB} \stackrel{\text{def}}{=} \sum_i (\langle i| \otimes \mathbb{I}_B) \rho_{AB} (|i\rangle \otimes \mathbb{I}_B),$$

where $\{|i\rangle\}_i$ is an orthonormal basis for the Hilbert space \mathcal{H}_A . The state $\rho_B \in \mathcal{D}(\mathcal{H}_B)$ is referred to as the marginal state of ρ_{AB} on the register B . Unless otherwise stated, a missing register from subscript in a state represents partial trace over that register. Given $\rho_A \in \mathcal{D}(\mathcal{H}_A)$, a *purification* of ρ_A is a pure state $\rho_{AB} \in \mathcal{D}(\mathcal{H}_{AB})$ such that $\text{Tr}_B \rho_{AB} = \rho_A$. Purification of a quantum state is not unique. Suppose $A \equiv B$. Given $\{|i\rangle_A\}$ and $\{|i\rangle_B\}$ as orthonormal bases over \mathcal{H}_A and \mathcal{H}_B respectively, the *canonical purification* of a quantum state ρ_A is $|\rho_A\rangle \stackrel{\text{def}}{=} (\rho_A^{\frac{1}{2}} \otimes \mathbb{I}_B) (\sum_i |i\rangle_A |i\rangle_B)$.

A quantum map $\mathcal{E} : \mathcal{L}(\mathcal{H}_A) \rightarrow \mathcal{L}(\mathcal{H}_B)$ is a completely positive and trace preserving (CPTP) linear map. A *Hermitian* operator $H : \mathcal{H}_A \rightarrow \mathcal{H}_A$ is such that $H = H^\dagger$. A projector $\Pi \in \mathcal{L}(\mathcal{H}_A)$ is a Hermitian operator such that $\Pi^2 = \Pi$. A *unitary* operator $V_A : \mathcal{H}_A \rightarrow \mathcal{H}_A$ is such that $V_A^\dagger V_A = V_A V_A^\dagger = \mathbb{I}_A$. The set of all unitary operators on \mathcal{H}_A is denoted by $\mathcal{U}(\mathcal{H}_A)$. An *isometry* $V : \mathcal{H}_A \rightarrow \mathcal{H}_B$ is such that $V^\dagger V = \mathbb{I}_A$ and $V V^\dagger = \mathbb{I}_B$. A *POVM* element is an operator $0 \leq M \leq \mathbb{I}$. We use the shorthand $\overline{M} \stackrel{\text{def}}{=} \mathbb{I} - M$, where \mathbb{I} is clear from the context. We use shorthand M to represent $M \otimes \mathbb{I}$, where \mathbb{I} is clear from the context.

A *classical-quantum* (c-q) state ρ_{XE} is of the form

$$\rho_{XE} = \sum_{x \in \mathcal{X}} p(x) |x\rangle\langle x| \otimes \rho_E^x,$$

where ρ_E^x are states. In a pure state ρ_{XEA} in which ρ_{XE} is c-q, we call X a classical register and identify random variable X with it with $\text{Pr}(X = x) = p(x)$. For an event $\mathcal{S} \subseteq \mathcal{X}$, define

$$\text{Pr}(\mathcal{S})_\rho \stackrel{\text{def}}{=} \sum_{x \in \mathcal{S}} p(x) \quad ; \quad (\rho|\mathcal{S}) \stackrel{\text{def}}{=} \frac{1}{\text{Pr}(\mathcal{S})_\rho} \sum_{x \in \mathcal{S}} p(x) |x\rangle\langle x| \otimes \rho_E^x.$$

For a function $Z : \mathcal{X} \rightarrow \mathcal{Z}$, define the following extension of ρ_{XE}

$$\rho_{ZXE} \stackrel{\text{def}}{=} \sum_{x \in \mathcal{X}} p(x) |Z(x)\rangle\langle Z(x)| \otimes |x\rangle\langle x| \otimes \rho_E^x.$$

We call an isometry $V : \mathcal{H}_X \otimes \mathcal{H}_A \rightarrow \mathcal{H}_X \otimes \mathcal{H}_B$, *safe* on X iff there is a collection of isometries $V_x : \mathcal{H}_A \rightarrow \mathcal{H}_B$ such that the following holds. For all states $|\psi\rangle_{XA} = \sum_x \alpha_x |x\rangle_X |\psi^x\rangle_A$,

$$V|\psi\rangle_{XA} = \sum_x \alpha_x |x\rangle_X V_x |\psi^x\rangle_A.$$

All the isometries considered in this paper are safe on classical registers they act upon. For a function $Z : \mathcal{X} \rightarrow \mathcal{Z}$, define $\rho_{Z\hat{Z}XEA}$ to be a pure state extension of ρ_{XEA} generated via a safe isometry

$V : \mathcal{H}_X \rightarrow \mathcal{H}_X \otimes \mathcal{H}_Z \otimes \mathcal{H}_{\hat{Z}}$ (Z classical with copy \hat{Z}). For a pure state ρ_{XE} and measurement \mathcal{M} in the computational basis on register X , define $\rho_{\hat{X}XE}$ a pure state extension post the measurement \mathcal{M} of state ρ_{XE} generated via a safe isometry $V : \mathcal{H}_X \rightarrow \mathcal{H}_X \otimes \mathcal{H}_{\hat{X}}$ such that $\rho_{\hat{X}XE} = V\rho_{XE}V^\dagger$ and \hat{X} a copy of X .

Definition 5. 1. For $p \geq 1$ and matrix A , let $\|A\|_p$ denote the Schatten p -norm defined as $\|A\|_p \stackrel{\text{def}}{=} (\text{Tr}(A^\dagger A)^{\frac{p}{2}})^{\frac{1}{p}}$.

2. For states $\rho, \sigma : \Delta(\rho, \sigma) \stackrel{\text{def}}{=} \frac{1}{2}\|\rho - \sigma\|_1$. We write $\rho \approx_\varepsilon \sigma$ to denote $\Delta(\rho, \sigma) \leq \varepsilon$.

3. **Fidelity:** For states $\rho, \sigma : \mathbb{F}(\rho, \sigma) \stackrel{\text{def}}{=} \|\sqrt{\rho}\sqrt{\sigma}\|_1$.

4. **Bures metric:** For states $\rho, \sigma : \Delta_B(\rho, \sigma) \stackrel{\text{def}}{=} \sqrt{1 - \mathbb{F}(\rho, \sigma)}$.

5. **Max-divergence** ([Dat09], see also [JRS02]): For states ρ, σ such that $\text{supp}(\rho) \subset \text{supp}(\sigma)$,

$$D_{\max}(\rho\|\sigma) \stackrel{\text{def}}{=} \min\{\lambda \in \mathbb{R} : \rho \leq 2^\lambda \sigma\}.$$

6. **Min-entropy and conditional-min-entropy:** For a state ρ_{XE} , the min-entropy of X is defined as,

$$H_{\min}(X)_\rho \stackrel{\text{def}}{=} -D_{\max}(\rho_X\|\mathbb{I}_X).$$

The conditional-min-entropy of X , conditioned on E , is defined as,

$$H_{\min}(X|E)_\rho \stackrel{\text{def}}{=} -\inf_{\sigma_E \in \mathcal{D}(\mathcal{H}_E)} D_{\max}(\rho_{XE}\|\mathbb{I}_X \otimes \sigma_E).$$

7. **Markov-chain:** A state ρ_{XEY} forms a Markov-chain (denoted $(X-E-Y)_\rho$) iff $\mathbb{I}(X : Y|E)_\rho = 0$ ⁷.

For the facts stated below without citation, we refer the reader to standard text books [NC00, Wat11].

Fact 1 (Uhlmann's Theorem [Uhl76]). Let $\rho_A, \sigma_A \in \mathcal{D}(\mathcal{H}_A)$. Let $\rho_{AB} \in \mathcal{D}(\mathcal{H}_{AB})$ be a purification of ρ_A and $\sigma_{AC} \in \mathcal{D}(\mathcal{H}_{AC})$ be a purification of σ_A . There exists an isometry V (from a subspace of \mathcal{H}_C to a subspace of \mathcal{H}_B) such that,

$$\Delta_B(|\theta\rangle\langle\theta|_{AB}, |\rho\rangle\langle\rho|_{AB}) = \Delta_B(\rho_A, \sigma_A),$$

where $|\theta\rangle_{AB} = (\mathbb{I}_A \otimes V)|\sigma\rangle_{AC}$.

Fact 2 ([CLW14]). Let $\mathcal{E} : \mathcal{L}(\mathcal{H}_M) \rightarrow \mathcal{L}(\mathcal{H}_{M'})$ be a CPTP map and let $\sigma_{XM'} = (\mathbb{I} \otimes \mathcal{E})(\rho_{XM})$. Then,

$$H_{\min}(X|M')_\sigma \geq H_{\min}(X|M)_\rho.$$

Above is equality iff \mathcal{E} is a CPTP map corresponding to an isometry.

⁷ $\mathbb{I}(A : B|C)_\rho$ represents conditional mutual information between registers A, B given register C in state ρ .

Fact 3 ([FvdG06]). *Let ρ, σ be states. Then,*

$$1 - \mathbb{F}(\rho, \sigma) \leq \Delta(\rho, \sigma) \leq \sqrt{1 - \mathbb{F}^2(\rho, \sigma)} \quad ; \quad \Delta_B^2(\rho, \sigma) \leq \Delta(\rho, \sigma) \leq \sqrt{2} \Delta_B(\rho, \sigma).$$

Fact 4 (Data-processing). *Let ρ, σ be states and \mathcal{E} be a CPTP map. Then*

- $\Delta(\mathcal{E}(\rho), \mathcal{E}(\sigma)) \leq \Delta(\rho, \sigma)$.
- $\Delta_B(\mathcal{E}(\rho), \mathcal{E}(\sigma)) \leq \Delta_B(\rho, \sigma)$.
- $D_{\max}(\mathcal{E}(\rho) \parallel \mathcal{E}(\sigma)) \leq D_{\max}(\rho \parallel \sigma)$.

The inequalities above are equalities in case Φ is a CPTP map corresponding to an isometry.

Fact 5. *Let ρ_{XE}, σ_{XE} be c-q states. Then,*

- $\|\rho_{XE} - \sigma_{XE}\|_1 \geq \mathbb{E}_{x \leftarrow \rho_X} \|\rho_E^x - \sigma_E^x\|_1$.
- $\Delta_B(\rho_{XE}, \sigma_{XE}) \geq \mathbb{E}_{x \leftarrow \rho_X} \Delta_B(\rho_E^x, \sigma_E^x)$.

The above inequalities are equalities iff $\rho_X = \sigma_X$.

Fact 6. *Let ρ, σ be states such that $\rho = \sum_x p_x \rho^x$, $\sigma = \sum_x p_x \sigma^x$, $\{\rho^x, \sigma^x\}_x$ are states and $\sum_x p_x = 1$. Then, $\Delta(\rho, \sigma) \leq \sum_x p_x \Delta(\rho^x, \sigma^x)$.*

Fact 7. *Let $\rho_{AB} \in \mathcal{D}(\mathcal{H}_A \otimes \mathcal{H}_B)$ be a state and $M \in \mathcal{L}(\mathcal{H}_B)$ such that $M^\dagger M \leq \mathbb{I}_B$. Let $\hat{\rho}_{AB} = \frac{M \rho_{AB} M^\dagger}{\text{Tr} M \rho_{AB} M^\dagger}$. Then,*

$$D_{\max}(\hat{\rho}_A \parallel \rho_A) \leq \log \left(\frac{1}{\text{Tr} M \rho_{AB} M^\dagger} \right).$$

Fact 8. *For random variables A, B such that $A = A_1 \otimes A_2$, $B = B_1 \otimes B_2$, we have*

$$\|A - B\|_1 = \|A_1 - B_1\|_1 + \|A_2 - B_2\|_1.$$

Fact 9. *For random variables $AB, \tilde{A}\tilde{B}$, we have*

$$\|\tilde{A}\tilde{B} - AB\|_1 \leq \|\tilde{B} - B\|_1 + \mathbb{E}_{b \leftarrow \tilde{B}} \|\tilde{A}(\tilde{B} = b) - A(B = b)\|_1.$$

Fact 10 (Folklore). *Let m, n be positive integers such that $m \leq n$. Let A be any $m \times n$ matrix over the Field \mathbb{F} . For any string $o \in \mathbb{F}^m$, let $S_o \stackrel{\text{def}}{=} \{x \in \mathbb{F}^n : Ax^\dagger = o^\dagger\}$. There exists an efficient algorithm that runs in time polynomial in $(m, n, |\mathbb{F}|)$ and outputs sample $x \leftarrow S_o$.*

Fact 11 (Corollary 5.2 in [CGL20]). *For any constant $\delta \in (0, 1)$, there exist constants α, β such that $3\beta \leq \alpha \leq 1/14$ and for all positive integers ν, r, t , with $r \geq \nu^\alpha$ and $t = \mathcal{O}(\nu^\beta)$ the following holds.*

There exists a polynomial time computable function $\text{Samp} : \{0, 1\}^r \rightarrow [\nu]^t$, such that for any set $\mathcal{S} \subset [\nu]$ of size $\delta\nu$,

$$\Pr(|\text{Samp}(U_r) \cap \mathcal{S}| \geq 1) \geq 1 - 2^{-\Omega(\nu^\alpha)}.$$

Definition 6. *Let $M = 2^m$. The inner product function, $\text{IP}_M^n : \mathbb{F}_M^n \times \mathbb{F}_M^n \rightarrow \mathbb{F}_M$ is defined as follows:*

$$\text{IP}_M^n(x, y) = \sum_{i=1}^n x_i y_i,$$

where the operations are over the Field \mathbb{F}_M .

Extractors and non-malleable-codes

Throughout the paper we use extractor to mean seeded-extractor unless stated otherwise.

Definition 7 (Quantum secure extractor). *An (n, d, m) -extractor $\text{Ext} : \{0, 1\}^n \times \{0, 1\}^d \rightarrow \{0, 1\}^m$ is said to be (k, ε) -quantum secure if for every state ρ_{XES} , such that $H_{\min}(X|E)_\rho \geq k$ and $\rho_{XES} = \rho_{XE} \otimes U_d$, we have*

$$\|\rho_{\text{Ext}(X,S)E} - U_m \otimes \rho_E\|_1 \leq \varepsilon.$$

In addition, the extractor is called strong if

$$\|\rho_{\text{Ext}(X,S)SE} - U_m \otimes U_d \otimes \rho_E\|_1 \leq \varepsilon.$$

S is referred to as the seed for the extractor.

Fact 12 ([DPVR12, CV17]). *There exists an explicit $(2m, \varepsilon)$ -quantum secure strong (n, d, m) -extractor $\text{Ext} : \{0, 1\}^n \times \{0, 1\}^d \rightarrow \{0, 1\}^m$ for parameters $d = \mathcal{O}(\log^2(n/\varepsilon) \log m)$. Moreover the extractor Ext is linear extractor, i.e. for every fixed seed, the output of the extractor is a linear function of the input source.*

Definition 8 (l -qma-state [ABJO21]). *Let $\tau_{X\hat{X}}, \tau_{Y\hat{Y}}$ be the canonical purifications of independent and uniform sources X, Y respectively. Let τ_{NM} be a pure state. Let*

$$\theta_{X\hat{X}NM\hat{Y}} = \tau_{X\hat{X}} \otimes \tau_{NM} \otimes \tau_{Y\hat{Y}}.$$

Let $U : \mathcal{H}_X \otimes \mathcal{H}_N \rightarrow \mathcal{H}_X \otimes \mathcal{H}_{N'} \otimes \mathcal{H}_A$ and $V : \mathcal{H}_Y \otimes \mathcal{H}_M \rightarrow \mathcal{H}_Y \otimes \mathcal{H}_{M'} \otimes \mathcal{H}_B$ be isometries such that registers A, B are single qubit registers. Let

$$\rho_{X\hat{X}AN'M'BY\hat{Y}} = (U \otimes V)\theta_{X\hat{X}NM\hat{Y}}(U \otimes V)^\dagger,$$

and

$$l = \log \left(\frac{1}{\Pr(A=1, B=1)_\rho} \right) \quad ; \quad \sigma_{X\hat{X}N'M'Y\hat{Y}} = (\rho_{X\hat{X}AN'M'BY\hat{Y}}|_{A=1, B=1}).$$

We call $\sigma_{X\hat{X}N'M'Y\hat{Y}}$ an l -qma-state .

Fact 13 (IP security against l -qma-state [ABJO21]). *Let $n = \frac{n_1}{m}$ and $n_1 - l \geq 2 \log(\frac{1}{\varepsilon}) + m$. Let $\sigma_{X\hat{X}N'M'Y\hat{Y}}$ be an l -qma-state with $|X| = |Y| = n_1$. Then*

$$\|\sigma_{\text{IP}_{2^m}^n(X,Y)XN'} - U_m \otimes \sigma_{XN'}\|_1 \leq \varepsilon \quad ; \quad \|\sigma_{\text{IP}_{2^m}^n(X,Y)YM'} - U_m \otimes \sigma_{YM'}\|_1 \leq \varepsilon.$$

Fact 14 (Theorem 8 in [CGL20]). *Let X, Y be independent sources on $\mathbb{F}_{2^m}^n$ with min-entropy k_1, k_2 respectively. Then*

$$\|\text{IP}_{2^m}^n(X, Y)Y - U_m \otimes Y\|_1 \leq \varepsilon \quad ; \quad \|\text{IP}_{2^m}^n(X, Y)X - U_m \otimes X\|_1 \leq \varepsilon,$$

where $\varepsilon = 2^{-\frac{(k_1+k_2-m)(n+1)}{2}}$.

Definition 9 ((k_1, k_2) -qma-state [BJK21]). *We call a pure state $\sigma_{X\hat{X}NM\hat{Y}}$, with (XY) classical and $(\hat{X}\hat{Y})$ copy of (XY) , a (k_1, k_2) -qma-state iff*

$$H_{\min}(X|MY\hat{Y})_\sigma \geq k_1 \quad ; \quad H_{\min}(Y|NX\hat{X})_\sigma \geq k_2.$$

Definition 10 ((k_1, k_2) -qnm-state [BJK21]). Let $\sigma_{X\hat{X}NM\hat{Y}}$ be a (k_1, k_2) -qma-state. Let $U : \mathcal{H}_X \otimes \mathcal{H}_N \rightarrow \mathcal{H}_X \otimes \mathcal{H}_{X'} \otimes \mathcal{H}_{\hat{X}'} \otimes \mathcal{H}_{N'}$ and $V : \mathcal{H}_Y \otimes \mathcal{H}_M \rightarrow \mathcal{H}_Y \otimes \mathcal{H}_{Y'} \otimes \mathcal{H}_{\hat{Y}'} \otimes \mathcal{H}_{M'}$ be isometries such that for $\rho = (U \otimes V)\sigma(U \otimes V)^\dagger$, we have $(X'Y')$ classical (with copy $\hat{X}'\hat{Y}'$) and,

$$\Pr(Y \neq Y')_\rho = 1 \quad \text{or} \quad \Pr(X \neq X')_\rho = 1.$$

We call state ρ a (k_1, k_2) -qnm-state.

Definition 11 (Quantum secure 2-source non-malleable-extractor [BJK21]). An (n, n, m) -non-malleable-extractor $2\text{nmExt} : \{0, 1\}^n \times \{0, 1\}^n \rightarrow \{0, 1\}^m$ is (k_1, k_2, ε) -secure against qnm-adv if for every (k_1, k_2) -qnm-state ρ (chosen by the adversary qnm-adv),

$$\|\rho_{2\text{nmExt}(X,Y)2\text{nmExt}(X',Y')YY'M'} - U_m \otimes \rho_{2\text{nmExt}(X',Y')YY'M'}\|_1 \leq \varepsilon,$$

and

$$\|\rho_{2\text{nmExt}(X,Y)2\text{nmExt}(X',Y')XX'N'} - U_m \otimes \rho_{2\text{nmExt}(X',Y')XX'N'}\|_1 \leq \varepsilon.$$

Error correcting codes

Definition 12. Let Σ be a finite set. A mapping $\text{ECC} : \Sigma^k \rightarrow \Sigma^n$ is called an error correcting code with relative distance γ if for any $x, y \in \Sigma^k$ such that $x \neq y$, the Hamming distance between $\text{ECC}(x)$ and $\text{ECC}(y)$ is at least γn . The rate of the code denoted by δ , is defined as $\delta \stackrel{\text{def}}{=} \frac{k}{n}$. The alphabet size of the code is the number of elements in Σ .

Fact 15 (MDS Codes). Let q be a prime power. For every positive integer k , there exists a large enough n such that there exists an efficiently computable linear error correcting code $\text{ECC} : \mathbb{F}_q^k \rightarrow \mathbb{F}_q^n$ with rate $\frac{k}{n}$ and relative distance $\frac{n-k+1}{n}$. Such codes are known as maximum distance separable (MDS) codes. Reed-Solomon codes is a typical example of an MDS code family.

Other useful facts, claims and lemmas

Fact 16 ([BJK21]). Let $\rho_{ABC} \in \mathcal{D}(\mathcal{H}_A \otimes \mathcal{H}_B \otimes \mathcal{H}_C)$ be a state and $M \in \mathcal{L}(\mathcal{H}_C)$ such that $M^\dagger M \leq \mathbb{I}_C$. Let $\hat{\rho}_{ABC} = \frac{M\rho_{ABC}M^\dagger}{\text{Tr}M\rho_{ABC}M^\dagger}$. Then,

$$\text{H}_{\min}(A|B)_{\hat{\rho}} \geq \text{H}_{\min}(A|B)_\rho - \log \left(\frac{1}{\text{Tr}M\rho_{ABC}M^\dagger} \right).$$

Fact 17 ([BJK21]). Let $\rho_{XE} \in \mathcal{D}(\mathcal{H}_X \otimes \mathcal{H}_E)$ be a c - q state such that $|X| = n$ and $\text{H}_{\min}(X|E)_\rho \geq n - k$. Let $\tilde{X} = \text{Crop}(X, d_1, d_2)$ for some positive integer $k \leq d_2 - d_1$ and $1 \leq d_1 < d_2 \leq n$. Then,

$$\text{H}_{\min}(\tilde{X}|E)_\rho \geq d_2 - d_1 + 1 - k.$$

Fact 18 ([BJK21]). Let $\rho_{X\hat{X}NY\hat{Y}M}$ be a (k_1, k_2) -qma-state such that $|X| = |\hat{X}| = |Y| = |\hat{Y}| = n$. There exists an l -qma-state, $\rho^{(1)}$ such that,

$$\Delta_B(\rho^{(1)}, \rho) \leq 3\varepsilon \quad \text{and} \quad l \leq 2n - k_1 - k_2 + 4 + 4 \log \left(\frac{1}{\varepsilon} \right).$$

Fact 19 (Quantum secure 2-source non-malleable-extractor [BJK21]). Let $k = \mathcal{O}(n^{1/4})$ and $\varepsilon = 2^{-n^{\Omega(1)}}$. There exists an efficient 2-source non-malleable-extractor $2\text{nmExt} : \{0, 1\}^n \times \{0, 1\}^n \rightarrow \{0, 1\}^{n/4}$ that is $(n - k, n - k, \mathcal{O}(\varepsilon))$ -quantum secure.

Fact 20 (Alternating-extraction [BJK21]). Let θ_{XASB} be a pure state with (XS) classical, $|X| = n, |S| = d$ and

$$\mathbb{H}_{\min}(X|SB)_\theta \geq k \quad ; \quad \Delta_B(\theta_{XAS}, \theta_{XA} \otimes U_d) \leq \varepsilon'.$$

Let $T \stackrel{\text{def}}{=} \text{Ext}(X, S)$ where Ext is a (k, ε) -quantum secure strong (n, d, m) -extractor. Then,

$$\Delta_B(\theta_{TB}, U_m \otimes \theta_B) \leq 2\varepsilon' + \sqrt{\varepsilon}.$$

Fact 21 (Min-entropy loss under classical interactive communication [BJK21]). Let ρ_{XNM} be a pure state where Alice holds registers (XN) and Bob holds register M , such that register X is classical and

$$\mathbb{H}_{\min}(X|M)_\rho \geq k.$$

Let Alice and Bob proceed for t -rounds, where in each round Alice generates a classical register R_i and sends it to Bob, followed by Bob generating a classical register S_i and sending it to Alice. Alice applies an isometry $V^i : \mathcal{H}_X \otimes \mathcal{H}_{N_{i-1}} \rightarrow \mathcal{H}_X \otimes \mathcal{H}_{N'_i} \otimes \mathcal{H}_{R_i}$ (in round i) to generate R_i . Let $\theta_{XN_i M_i}^i$ be the state at the end of round- i , where Alice holds registers XN_i and Bob holds register M_i . Then,

$$\mathbb{H}_{\min}(X|M_t)_{\theta^t} \geq k - \sum_{j=1}^t |R_j|.$$

Claim 1. Let $\sigma_{X\hat{X}NY\hat{Y}M}$ be a (k_1, k_2) -qma-state with $|X| = n$ and $|Y| = n$. Let $2\text{nmExt} : \{0, 1\}^n \times \{0, 1\}^n \rightarrow \{0, 1\}^m$ be an efficient (k_1, k_2, ε) -quantum secure 2-source non-malleable-extractor. Let $S = 2\text{nmExt}(X, Y)$. Then,

$$\|\sigma_{SYM} - U_m \otimes \sigma_{YM}\|_1 \leq \varepsilon.$$

Proof. Let $U : \mathcal{H}_X \rightarrow \mathcal{H}_X \otimes \mathcal{H}_{X'}$, $V : \mathcal{H}_Y \rightarrow \mathcal{H}_Y \otimes \mathcal{H}_{Y'}$, be (safe) isometries such that for $\rho = (U \otimes V)\sigma(U \otimes V)^\dagger$, we have $X'Y'$ classical (with copies $\hat{X}'\hat{Y}'$ respectively) and either $\Pr(X \neq X')_\rho = 1$ or $\Pr(Y \neq Y')_\rho = 1$.⁸ Notice the state ρ is a (k_1, k_2) -qnm-state. Since 2nmExt is a (k_1, k_2, ε) -quantum secure 2-source non-malleable-extractor (see Definition 11), we have

$$\|\rho_{SS'Y'Y'M} - U_m \otimes \rho_{S'Y'Y'M}\|_1 \leq \varepsilon.$$

Using Fact 4, we further get

$$\|\rho_{SYM} - U_m \otimes \rho_{YM}\|_1 \leq \varepsilon.$$

The desired now follows by noting $\sigma_{XNMY} = \rho_{XNMY}$. □

Claim 2. Let random variables $ABC, \tilde{A}\tilde{B}\tilde{C}$ be such that

$$A \leftrightarrow B \leftrightarrow C \quad ; \quad \tilde{A} \leftrightarrow \tilde{B} \leftrightarrow \tilde{C} \quad ; \quad \|AB - \tilde{A}\tilde{B}\|_1 \leq \varepsilon_1 \quad ; \quad \|BC - \tilde{B}\tilde{C}\|_1 \leq \varepsilon_2.$$

Then,

$$\|ABC - \tilde{A}\tilde{B}\tilde{C}\| \leq 2\varepsilon_1 + \varepsilon_2.$$

⁸It is easily seen that such isometries exists.

Proof. Since $\|AB - \tilde{A}\tilde{B}\|_1 \leq \varepsilon_1$, using Fact 4, we have

$$\|B - \tilde{B}\|_1 \leq \varepsilon_1. \quad (1)$$

Since $A \leftrightarrow B \leftrightarrow C$, $\tilde{A} \leftrightarrow \tilde{B} \leftrightarrow \tilde{C}$, we have

$$(AC)|(B=b) = A|(B=b) \otimes C|(B=b) \quad ; \quad (\tilde{A}\tilde{C})|(\tilde{B}=b) = \tilde{A}|(\tilde{B}=b) \otimes \tilde{C}|(\tilde{B}=b). \quad (2)$$

Consider,

$$\begin{aligned} \|\tilde{A}\tilde{B}\tilde{C} - ABC\|_1 &\leq \|\tilde{B} - B\|_1 + \mathbb{E}_{b \leftarrow \tilde{B}} \|(\tilde{A}\tilde{C})|(\tilde{B}=b) - (AC)|(B=b)\|_1 && \text{(Fact 9)} \\ &= \|\tilde{B} - B\|_1 + \mathbb{E}_{b \leftarrow \tilde{B}} \|\tilde{A}|(\tilde{B}=b) \otimes \tilde{C}|(\tilde{B}=b) - A|(B=b) \otimes C|(B=b)\|_1 && \text{(Eq. (2))} \\ &= \|\tilde{B} - B\|_1 + \mathbb{E}_{b \leftarrow \tilde{B}} \left(\|\tilde{A}|(\tilde{B}=b) - A|(B=b)\|_1 + \|\tilde{C}|(\tilde{B}=b) - C|(B=b)\|_1 \right) && \text{(Fact 8)} \\ &= \|\tilde{B} - B\|_1 + \mathbb{E}_{b \leftarrow \tilde{B}} \left(\|\tilde{A}|(\tilde{B}=b) - A|(B=b)\|_1 \right) + \mathbb{E}_{b \leftarrow \tilde{B}} \left(\|\tilde{C}|(\tilde{B}=b) - C|(B=b)\|_1 \right) \\ &\leq \|\tilde{B} - B\|_1 + \|\tilde{A}\tilde{B} - AB\|_1 + \|\tilde{B}\tilde{C} - BC\|_1 && \text{(Fact 5)} \\ &\leq \varepsilon_1 + \|\tilde{A}\tilde{B} - AB\|_1 + \|\tilde{B}\tilde{C} - BC\|_1 && \text{(Eq. (1))} \\ &\leq 2\varepsilon_1 + \varepsilon_2. \end{aligned}$$

This completes the proof. \square

Since the construction of the quantum secure non-malleable-extractor is composed of alternating extraction using Ext from Fact 12, we first state a claim about the invertibility of the Ext given the output (close to the desired).

Claim 3. Let $\text{Ext} : \{0, 1\}^n \times \{0, 1\}^d \rightarrow \{0, 1\}^m$ be an explicit $(2m, \varepsilon)$ -quantum secure strong extractor from Fact 12 or IP from Fact 14⁹ with error ε ¹⁰. Let X, H, O, \tilde{O} be random variables such that,

$$\|XH - U_n \otimes U_d\|_1 \leq \varepsilon' \quad ; \quad O = \text{Ext}(X, H) \quad ; \quad \|\tilde{O} - U_m\|_1 \leq \varepsilon''.$$

Given samples from $(\tilde{o}, \tilde{h}) \leftarrow \tilde{O}\tilde{H} = \tilde{O} \otimes U_d$, we can sample from $\tilde{X}|(\tilde{O}\tilde{H} = \tilde{o}\tilde{h})$ (which is same as sampling $\tilde{x} \leftarrow \{x : \text{Ext}(x, \tilde{h}) = \tilde{o}\}$) in time polynomial in (m, n) such that

$$\|\tilde{O}\tilde{H}\tilde{X} - OHX\|_1 \leq \varepsilon + \varepsilon' + \varepsilon'' \quad ; \quad \tilde{O} = \text{Ext}(\tilde{X}, \tilde{H}).$$

Proof. Let $\hat{X}\hat{H} = U_n \otimes U_d$ and $\hat{O} = \text{Ext}(\hat{X}, \hat{H})$ be the output of the extractor. Since $\|XH - \hat{X}\hat{H}\|_1 \leq \varepsilon'$, using Fact 4 we have

$$\|OXH - \hat{O}\hat{X}\hat{H}\|_1 \leq \varepsilon'. \quad (3)$$

Also, since $\hat{O} = \text{Ext}(\hat{X}, \hat{H})$ is the output of the strong extractor, we have

$$\|\hat{O}\hat{H} - U_m \otimes U_d\|_1 \leq \varepsilon.$$

Since $\tilde{O}\tilde{H} = \tilde{O} \otimes U_d$ and $\|\tilde{O} - U_m\|_1 \leq \varepsilon''$, we have $\|\tilde{O}\tilde{H} - U_m \otimes U_d\|_1 \leq \varepsilon''$. Using triangle inequality, we have

$$\|\hat{O}\hat{H} - \tilde{O}\tilde{H}\|_1 \leq \varepsilon + \varepsilon''. \quad (4)$$

⁹Inputs are of same size in this case, i.e. $d = n$.

¹⁰We assume there is enough min-entropy in the sources for the extractors to work.

We now proceed by noting that the extractor is linear. In other words, for every seed $H = h$, the output of the extractor $O = o$ is a linear function of the input $X = x$. For a fixed output o of the extractor and seed h , we have a matrix A_h of size $m \times n$ such that $A_h x^\dagger = o^\dagger$. Note for any fixing of the seed h and output o , the size of the set $\{x : \text{Ext}(x, h) = o\}$ is $2^{n - \text{rank}(A_h)}$ and sampling x uniformly from the set can be done efficiently from Fact 10.

Given samples $(\tilde{o}, \tilde{h}) \leftarrow \tilde{O}\tilde{H} = \tilde{O} \otimes U_d$, we use the following sampling strategy:

- Sample $\tilde{x} \leftarrow \tilde{X} | (\tilde{O}\tilde{H} = \tilde{o}\tilde{h})$ which is same as sampling $\tilde{x} \leftarrow \{x : \text{Ext}(x, \tilde{h}) = \tilde{o}\}$.

Note for any fixing of the seed \tilde{h} and output \tilde{o} of the extractor, $\tilde{X} | (\tilde{O}\tilde{H} = \tilde{o}\tilde{h}) = \tilde{X} | (\tilde{O}\tilde{H} = \tilde{o}\tilde{h})$ since $\tilde{X}\tilde{H} = U_n \otimes U_d$. Thus, from Fact 4 and Eq. (4), we have

$$\|\hat{O}\hat{X}\hat{H} - \tilde{O}\tilde{X}\tilde{H}\|_1 \leq \varepsilon + \varepsilon''. \quad (5)$$

Using Eqs. (3), (5) along with triangle inequality, we have the desired. \square

Corollary 1. *Let $\text{Ext} : \{0, 1\}^n \times \{0, 1\}^d \rightarrow \{0, 1\}^m$ be an explicit $(2m, \varepsilon)$ -quantum secure strong extractor from Fact 12 or IP from Fact 14¹¹ with error ε . Let*

$$\|XH - U_n \otimes U_d\|_1 \leq \varepsilon' \quad ; \quad O = \text{Ext}(X, H).$$

Then, $\|O - U_m\|_1 \leq \varepsilon + \varepsilon'$.

Proof. Let $\hat{X}\hat{H} = U_n \otimes U_d$ and $\hat{O} = \text{Ext}(\hat{X}, \hat{H})$ be the output of the extractor. Since $\|XH - \hat{X}\hat{H}\|_1 \leq \varepsilon'$, using Fact 4 we have

$$\|OXH - \hat{O}\hat{X}\hat{H}\|_1 \leq \varepsilon'.$$

Using Fact 4 again, we further have

$$\|O - \hat{O}\|_1 \leq \varepsilon'. \quad (6)$$

Also, since $\hat{O} = \text{Ext}(\hat{X}, \hat{H})$ is the output of the extractor, we have

$$\|\hat{O} - U_m\|_1 \leq \varepsilon.$$

Using Eq. (6) along with triangle inequality, we have the desired. \square

Lemma 1. *Let $\text{ECC} : \mathbb{F}_q^k \rightarrow \mathbb{F}_q^n$ be an $(n, k, n - k + 1)$ Reed-Solomon code from Fact 15 for $q \geq n + 1$. Let random variable $M \in \mathbb{F}_q^k$ be uniformly distributed over \mathbb{F}_q^k . Let $C = \text{ECC}(M)$ and t be any positive integer such that $t < k$. Let \mathcal{S} be a subset of $[n]$ such that $|\mathcal{S}| = t$ and \mathcal{Q} be a subset of $[k]$ such that $|\mathcal{Q}| = j \leq k - t$. Then, for every fixed string c in \mathbb{F}_q^t and $C^{\mathcal{S}} = c$ ¹², the distribution $M^c \stackrel{\text{def}}{=} M | (C^{\mathcal{S}} = c)$ is such that $(M^c)^{\mathcal{Q}} = U_{j \log q}$. Further more, for any fixed string l in \mathbb{F}_q^j , we can efficiently (in time polynomial in (k, q)) sample from the distribution $(M^c)^{[k] \setminus \mathcal{Q}} | ((M^c)^{\mathcal{Q}} = l)$.*

Proof. The generator matrix for ECC is given by

$$G = \begin{pmatrix} 1 & \alpha_1 & \dots & \alpha_1^{k-1} \\ 1 & \alpha_2 & \dots & \alpha_2^{k-1} \\ \vdots & \vdots & \ddots & \vdots \\ 1 & \alpha_n & \dots & \alpha_n^{k-1} \end{pmatrix},$$

¹¹Inputs are of same size in this case, i.e. $d = n$.

¹² $C^{\mathcal{S}}$ corresponds to codeword corresponding to columns \mathcal{S} of codeword C .

where $\alpha_1, \alpha_2, \dots, \alpha_n$ are distinct non-zero elements of \mathbb{F}_q (this is possible since $q \geq n + 1$). Let $\mathcal{S} = \{s_1, s_2, \dots, s_t\}$ and

$$G_{\mathcal{S}} = \begin{pmatrix} 1 & \alpha_{s_1} & \dots & \alpha_{s_1}^{k-1} \\ 1 & \alpha_{s_2} & \dots & \alpha_{s_2}^{k-1} \\ \vdots & \vdots & \ddots & \vdots \\ 1 & \alpha_{s_t} & \dots & \alpha_{s_t}^{k-1} \end{pmatrix}.$$

Note we have $G_{\mathcal{S}}M^\dagger = (C^{\mathcal{S}})^\dagger$. By fixing $C^{\mathcal{S}} = c$, we have imposed the following linear constraints as given by $G_{\mathcal{S}}M^{c^\dagger} = c^\dagger$. Note $G_{\mathcal{S}}$ is a Vandermonde matrix for any fixed subset $\mathcal{S} \subset [n]$, $|\mathcal{S}| = t$ and $t < k$. Thus, any $t \times t$ submatrix of $G_{\mathcal{S}}$ has full rank. Note $k - j \geq t$. Note M^c is exactly the distribution, $m \leftarrow \{m \in \mathbb{F}_q^k : G_{\mathcal{S}}m^\dagger = c^\dagger\}$. Let $\mathcal{P} = [k] \setminus \mathcal{Q}$ and $\mathcal{P} = \{p_1, p_2, \dots, p_{k-j}\}$ with elements in the set \mathcal{P} in any fixed order. Equivalent way to define M^c is the distribution, $m \leftarrow \{m \in \mathbb{F}_q^k : \tilde{G}m^\dagger = \tilde{c}^\dagger\}$, such that \tilde{G} is $t \times k$ matrix, the submatrix of \tilde{G} corresponding to columns given by $\mathcal{P}' = \{p_1, p_2, \dots, p_t\}$ is exactly $\mathbb{I}_{t \times t}$ (since any $t \times t$ submatrix of $G_{\mathcal{S}}$ has full rank). Note one can get (\tilde{G}, \tilde{c}) from $(G_{\mathcal{S}}, c)$ using standard Gaussian elimination procedure (in time polynomial in (k, q)). Thus, sampling $m = (m_1, m_2, \dots, m_t)$ from the distribution M^c can be achieved as follows:

- Sample for every $i \in \mathcal{Q}$, m_i uniformly and independently from \mathbb{F}_q .
- Sample for every $i \in \mathcal{P} \setminus \mathcal{P}'$, m_i uniformly and independently from \mathbb{F}_q .
- For every $i \in \mathcal{P}'$, set $m_i \in \mathbb{F}_q$ such that it satisfies the linear constraints $\tilde{G}_i m^\dagger = \tilde{c}^\dagger$.¹³

Thus, $(M^c)^\mathcal{Q} = U_{j \log q}$. Further more, for any fixed string l in \mathbb{F}_q^j , we can efficiently (in time polynomial in (k, q)) sample from the distribution $(M^c)^{[k] \setminus \mathcal{Q}} | ((M^c)^\mathcal{Q} = l)$. \square

3 A quantum secure non-malleable-code in the split-state model

Theorem 5 (Quantum secure non-malleable-code in the split-state model). *Let $2\text{nmExt} : \{0, 1\}^n \times \{0, 1\}^n \rightarrow \{0, 1\}^m$ be an $(n - k, n - k, \varepsilon)$ -quantum secure 2-source non-malleable-extractor. There exists an (m, n, ε') -quantum secure non-malleable-code with parameter $\varepsilon' = 4(2^{-k} + \varepsilon) + \varepsilon$.*

Proof. Let $\sigma_S = U_m$. Given a $2\text{nmExt} : \{0, 1\}^n \times \{0, 1\}^n \rightarrow \{0, 1\}^m$, let (Enc, Dec) be defined as follows:

- For any fixed message $S = s \in \{0, 1\}^m$, the encoder, Enc outputs a uniformly random string from the set $2\text{nmExt}^{-1}(s) \subset \{0, 1\}^{2n}$.
- $\text{Dec}(x, y) = 2\text{nmExt}(x, y)$ for every $(x, y) \in \{0, 1\}^{2n}$.

Note for every $s \in \{0, 1\}^m$, $\Pr(\text{Dec}(\text{Enc}(s))) = 1$. Thus, (Enc, Dec) is a standard encoding and decoding scheme in the split-state model (see Definition 1).

¹³Note the variables in \mathcal{Q} that appear in this linear constraint are already sampled before.

We first show that (Enc, Dec) is a quantum secure non-malleable-code in the split-state model (see Definition 4 and Figure 1). Note

$$\sigma_{S\text{Enc}(S)} = \sigma_{SXY} = \sum_{s \in \{0,1\}^m} \left(\frac{1}{2^m} |s\rangle\langle s| \otimes \left(\frac{1}{|2\text{nmExt}^{-1}(s)|} \sum_{(x,y):2\text{nmExt}(x,y)=s} |xy\rangle\langle xy| \right) \right)$$

after encoding a uniform message S . Note $(X, Y) = \text{Enc}(S)$.

Let $\theta_{X\hat{X}X_1Y\hat{Y}Y_1} = \theta_{X\hat{X}X_1} \otimes \theta_{Y\hat{Y}Y_1}$ be a pure state such that $\theta_X = \theta_Y = U_n$, (X_1, \hat{X}) are copies of X , (Y_1, \hat{Y}) are copies of Y respectively. Note $\theta_{XY} = U_n \otimes U_n$. Let $S_1 = 2\text{nmExt}(X_1, Y_1)$, $S = 2\text{nmExt}(X, Y)$. For the state θ with the following assignment (terms on the left are from Definition 9 and on the right are from here),

$$(X, \hat{X}, N, M, Y, \hat{Y}) \leftarrow (X_1, \hat{X}, X, Y, Y_1, \hat{Y}),$$

one can note θ is an (n, n) -qma-state. Using Claim 1¹⁴ along with Fact 4, we have

$$\|\theta_{2\text{nmExt}(X_1, Y_1)} - U_m\|_1 \leq \varepsilon.$$

Thus,

$$\|\theta_{S_1XY} - \sigma_{SXY}\|_1 \leq \|\theta_{S_1} - U_m\|_1 \leq \varepsilon. \quad (7)$$

First inequality follows from Fact 4 and noting

$$\theta_{XY}|(S_1 = s) = \sigma_{XY}|(S = s) = \left(\frac{1}{|2\text{nmExt}^{-1}(s)|} \sum_{(x,y):2\text{nmExt}(x,y)=s} |xy\rangle\langle xy| \right).$$

Let $\mathcal{A} = (U, V, \psi)$ be the quantum split-state adversary from Definition 3. Note ψ_{NM} is an entangled pure state, $U : \mathcal{H}_X \otimes \mathcal{H}_N \rightarrow \mathcal{H}_{X'} \otimes \mathcal{H}_{N'}$ and $V : \mathcal{H}_Y \otimes \mathcal{H}_M \rightarrow \mathcal{H}_{Y'} \otimes \mathcal{H}_{M'}$ are isometries without any loss of generality.

In the analysis, we consider a pure state ρ' which is generated from $\theta_{X\hat{X}X_1Y\hat{Y}Y_1} = \theta_{X\hat{X}X_1} \otimes \theta_{Y\hat{Y}Y_1}$, in the following way (see Figure 2):

- Let $\hat{\rho}' = (U \otimes V)(\theta \otimes |\psi\rangle\langle\psi|)(U \otimes V)^\dagger$ be the state after the action of quantum split-state adversary.
- Let ρ' be the pure state extension after measuring the registers $(X'Y')$ in the computational basis in $\hat{\rho}'$. Note the measurement in the computational basis of registers (X', Y') corresponds to applying CNOT¹⁵ to modify $(X', Y') \rightarrow (X'\hat{X}', Y'\hat{Y}')$ such that \hat{X}', \hat{Y}' are copies of X', Y' respectively.

Let binary variables C, D (with copies \hat{C}, \hat{D}) be such that $C = 1$ indicates $X_1 \neq X'$ and $D = 1$ indicates $Y_1 \neq Y'$ (in state ρ').

Let $S' = 2\text{nmExt}(X', Y')$. Since $\|\theta_{S_1XY} - \sigma_{SXY}\|_1 \leq \varepsilon$ from Eq. (7), using Fact 4 we have $\|\rho'_{S_1S'} - \rho_{SS'}\|_1 \leq \varepsilon$. We will show

¹⁴ (n, n) -qma-state is also an $(n - k, n - k)$ -qma-state.

¹⁵By CNOT on n qubit register, we mean applying NOT gate on different ancilla each time conditioned on each qubit independently. This operation amounts to performing measurement in the computational basis.

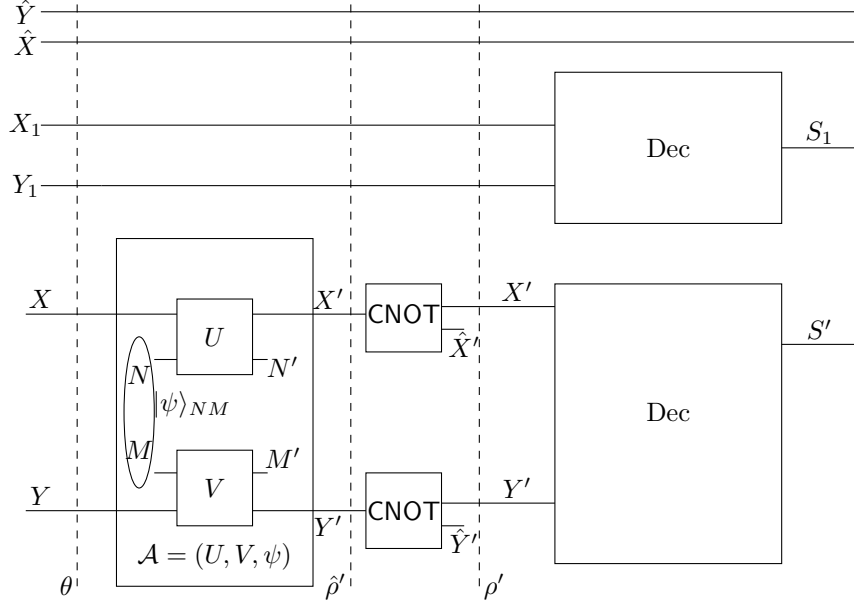

Figure 2:

$$\|\rho'_{S_1 S'} - \text{Zcopy}(\mathcal{D}_A, Z)\|_1 \leq 4(2^{-k} + \varepsilon), \quad (8)$$

for $Z = U_m$ and distribution \mathcal{D}_A that depends only on \mathcal{A} . We get the desired

$$\|\rho_{SS'} - \text{Zcopy}(\mathcal{D}_A, Z)\|_1 \leq 4(2^{-k} + \varepsilon) + \varepsilon,$$

from $\|\rho'_{S_1 S'} - \rho_{SS'}\|_1 \leq \varepsilon$ and the triangle inequality.

We now proceed to prove Eq. (8). For $C = c \in \{0, 1\}, D = d \in \{0, 1\}$, denote $\rho'^{c,d} = \rho'|((C, D) = (c, d))$.

Claim 4. For every $c, d \in \{0, 1\}$ except $(c, d) = (0, 0)$, we have

$$\Pr((C, D) = (c, d))_{\rho'} \|\rho'^{c,d}_{S_1 S'} - Z \otimes \rho'^{c,d}_{S'}\|_1 \leq 2^{-k} + \varepsilon.$$

For $(c, d) = (0, 0)$, we have

$$\Pr((C, D) = (c, d))_{\rho'} \|\rho'^{c,d}_{S_1 S'} - ZZ\|_1 \leq 2^{-k} + \varepsilon,$$

where $Z = U_m$.

Proof. Fix $c, d \in \{0, 1\}$. Suppose $\Pr((C, D) = (c, d))_{\rho'} \leq 2^{-k}$, then we are done. Thus we assume otherwise. Note in state ρ' , we have

$$\rho'_{X_1 Y_1 \hat{Y}' \hat{Y} M' D \hat{D}} = U_n \otimes \rho'_{Y_1 \hat{Y}' \hat{Y} M' D \hat{D}} \quad ; \quad \rho'_{Y_1 X_1 X' \hat{X}' \hat{X} N' C \hat{C}} = U_n \otimes \rho'_{X_1 X' \hat{X}' \hat{X} N' C \hat{C}}.$$

Thus,

$$\mathbb{H}_{\min}\left(X_1 \middle| Y_1 Y' \hat{Y}' \hat{Y} M' D \hat{D}\right)_{\rho'} = n \quad ; \quad \mathbb{H}_{\min}\left(Y_1 \middle| X_1 X' \hat{X}' \hat{X} N' C \hat{C}\right)_{\rho'} = n.$$

Using Fact 2, we have

$$\mathbb{H}_{\min}\left(X_1 \middle| Y_1 Y' \hat{Y}' \hat{Y} M'\right)_{\rho'} = n \quad ; \quad \mathbb{H}_{\min}\left(Y_1 \middle| X_1 X' \hat{X}' \hat{X} N'\right)_{\rho'} = n.$$

We use Fact 16, with the following assignment of registers (below the registers on the left are from Fact 16 and the registers on the right are the registers in this proof),

$$(\rho_A, \rho_B, \rho_C) \leftarrow (\rho'_{X_1}, \rho'_{Y_1 Y' \hat{Y}' \hat{Y} M'}, \rho'_{C D}).$$

From Fact 16, we get that

$$\mathbb{H}_{\min}\left(X_1 \middle| Y_1 Y' \hat{Y}' \hat{Y} M'\right)_{\rho^{c,d}} \geq n - k.$$

Similarly $\mathbb{H}_{\min}\left(Y_1 \middle| X_1 X' \hat{X}' \hat{X} N'\right)_{\rho^{c,d}} \geq n - k$.

Let $(c, d) = (0, 0)$. Note $\rho^{0,0}$ is an $(n - k, n - k)$ -qma-state. Using Claim 1 along with Fact 4, we have $\|\rho_{2\text{nmExt}(X_1, Y_1)}^{0,0} - Z\|_1 \leq \varepsilon$. We also have $X_1 = X'$ and $Y_1 = Y'$ in $\rho^{0,0}$. Thus Fact 4 will imply

$$\|\rho_{S_1 S'}^{0,0} - Z\|_1 \leq \varepsilon.$$

Let $(c, d) \neq (0, 0)$. Note $\rho^{c,d}$ is an $(n - k, n - k)$ -qnm-state since either $\Pr(X_1 \neq X') = 1$ or $\Pr(Y_1 \neq Y') = 1$ in $\rho^{c,d}$. Since, $2\text{nmExt} : \{0, 1\}^n \times \{0, 1\}^n \rightarrow \{0, 1\}^m$ is an $(n - k, n - k, \varepsilon)$ -quantum secure 2-source non-malleable-extractor (see Definition 11), using Fact 4 we have

$$\|\rho_{S_1 S'}^{c,d} - Z \otimes \rho_{S'}^{c,d}\|_1 \leq \varepsilon.$$

This completes the proof. \square

For every $c, d \in \{0, 1\}$ except $(c, d) = (0, 0)$, let $\mathcal{D}_A^{c,d} = \rho_{S'}^{c,d}$ and for $(c, d) = (0, 0)$, let $\mathcal{D}_A^{0,0}$ be the distribution that is deterministically equal to same. Let $\mathcal{D}_A = \sum_{c,d \in \{0,1\}} \Pr((C, D) = (c, d))_{\rho'} \mathcal{D}_A^{c,d}$. Note for every $c, d \in \{0, 1\}$, the value $\Pr((C, D) = (c, d))_{\rho'}$ depends only on \mathcal{A} . We have,

$$\rho'_{S_1 S'} = \sum_{c,d \in \{0,1\}} \Pr((C, D) = (c, d))_{\rho'} \rho_{S_1 S'}^{c,d}, \quad (9)$$

and

$$\text{Zcopy}(\mathcal{D}_A, Z) = \sum_{c,d \in \{0,1\}} \Pr((C, D) = (c, d))_{\rho'} \text{Zcopy}(\mathcal{D}_A^{c,d}, Z). \quad (10)$$

Consider,

$$\begin{aligned} & \|\rho'_{S_1 S'} - \text{Zcopy}(\mathcal{D}_A, Z)\|_1 \\ &= \left\| \sum_{c,d \in \{0,1\}} \Pr((C, D) = (c, d))_{\rho'} \rho_{S_1 S'}^{c,d} - \text{Zcopy}(\mathcal{D}_A, Z) \right\|_1 \quad (\text{Eq. (9)}) \\ &\leq \sum_{c,d \in \{0,1\}} \Pr((C, D) = (c, d))_{\rho'} \|\rho_{S_1 S'}^{c,d} - \text{Zcopy}(\mathcal{D}_A^{c,d}, Z)\|_1 \quad (\text{Eq. (10) and Fact 6}) \\ &\leq (2^{-k} + \varepsilon)4. \quad (\text{Claim 4}) \end{aligned}$$

This completes the proof. \square

4 Efficient quantum secure non-malleable-codes

4.1 Modified non-malleable-extractor

These parameters hold throughout this section.

Parameters

Let $\delta, \delta_1, \delta_2 > 0$ be small enough constants such that $\delta_1 < \delta_2$. Let $n, n_1, n_2, n_3, n_4, n_5, n_6, n_7, n_x, n_y, a, s, b, h$ be positive integers and $\varepsilon', \varepsilon > 0$ such that:

$$n_1 = n^{\delta_2} \quad ; \quad n_2 = n - 3n_1 \quad ; \quad q = 2^{\log(n+1)} \quad ; \quad \varepsilon = 2^{-\mathcal{O}(n^{\delta_1})} \quad ;$$

$$n_3 = \frac{n_1}{10} \quad ; \quad n_4 = \frac{n_2}{\log(n+1)} \quad ; \quad n_5 = n^{\delta_2/3} \quad ; \quad a = 6n_1 + 2\mathcal{O}(n_5) \log(n+1) = \mathcal{O}(n_1) \quad ;$$

$$n_6 = 3n_1^3 \quad ; \quad n_7 = n - 3n_1 - n_6 \quad ; \quad n_x = \frac{n_7}{12a} \quad ; \quad n_y = \frac{n_7}{12a} \quad ; \quad 2^{\mathcal{O}(a)} \sqrt{\varepsilon'} = \varepsilon \quad ;$$

$$s = \mathcal{O}\left(\log^2\left(\frac{n}{\varepsilon'}\right) \log n\right) \quad ; \quad b = \mathcal{O}\left(\log^2\left(\frac{n}{\varepsilon'}\right) \log n\right) \quad ; \quad h = 10s$$

- IP_1 be $\text{IP}_{2^{n_3}}^{3n_1/n_3}$,
- Ext_1 be $(2b, \varepsilon')$ -quantum secure (n_y, s, b) -extractor,
- Ext_2 be $(2s, \varepsilon')$ -quantum secure (h, b, s) -extractor,
- Ext_3 be $(4h, \varepsilon')$ -quantum secure $(n_x, b, 2h)$ -extractor,
- Ext_4 be $(n_y/4, \varepsilon^2)$ -quantum secure $(4n_y, 2h, n_y/8)$ -extractor,
- IP_2 be $\text{IP}_{2^{2h}}^{3n_1^3/2h}$,
- Ext_6 be $(\frac{n_x}{2}, \varepsilon^2)$ -quantum secure $(4n_x, n_y/8, n_x/4)$ -extractor.

We first describe a short overview of the modifications required in the construction of non-malleable-extractor for the efficient encoding of quantum secure non-malleable-code in the split-state model. We modify the construction of 2nmExt from [BJK21], using ideas from [CGL20] to construct a $\text{new-}2\text{nmExt} : \{0, 1\}^n \times \{0, 1\}^n \rightarrow \{0, 1\}^m$ that is $(n - n_1, n - n_1, \varepsilon)$ -secure against qnm-adv for parameters $n_1 = n^{\Omega(1)}$, $m = n^{1-\Omega(1)}$ and $\varepsilon = 2^{-n^{\Omega(1)}}$. We divide the sources X and Y into $n^{\Omega(1)}$ blocks each of size $n^{1-\Omega(1)}$. The idea now is to use new blocks of X and Y for each round of alternating extraction in the construction of non-malleable-extractor. This enables the linear constraints that are imposed in the alternating extraction are on different variables of input sources, X, Y . Also, since X and Y each have almost full min-entropy, we have block sources, where each block has almost full min-entropy using Fact 17. This allows us to generate appropriate intermediate seed random variables (approximately uniform) using alternating extraction.

Definition of modified non-malleable-extractor

Let $\text{ECC} : \mathbb{F}_q^{n_4} \rightarrow \mathbb{F}_q^n$ be an $(n, n_4, n - n_4 + 1)$ Reed-Solomon code from Fact 15. Let $\text{Samp} : \{0, 1\}^r \rightarrow [n]^{t_1}$ be the sampler function from Fact 11 where $t_1 = \mathcal{O}(n_5)$ and $r \geq n_3$. We identify the output of Samp as t_1 samples from the set $[n]$. By $\text{ECC}(Y)_{\text{Samp}(I)}$, we mean the $\text{Samp}(I)$ entries of codeword $\text{ECC}(Y)$.

Algorithm 1 : $\text{new-2nmExt} : \{0, 1\}^n \times \{0, 1\}^n \rightarrow \{0, 1\}^{n_x/4}$

Input: X, Y

1. Advice generator:

$$X_1 = \text{Crop}(X, 1, 3n_1) \quad ; \quad Y_1 = \text{Crop}(Y, 1, 3n_1) \quad ; \quad R = \text{IP}_1(X_1, Y_1) \quad ;$$

$$X_2 = \text{Crop}(X, 3n_1 + 1, n) \quad ; \quad Y_2 = \text{Crop}(Y, 3n_1 + 1, n) \quad ;$$

$$G = X_1 \circ \bar{X}_2 \circ Y_1 \circ \bar{Y}_2 = X_1 \circ \text{ECC}(X_2)_{\text{Samp}(R)} \circ Y_1 \circ \text{ECC}(Y_2)_{\text{Samp}(R)}$$

2. $X_3 = \text{Crop}(X, 3n_1 + 1, 3n_1 + n_6) \quad ; \quad Y_3 = \text{Crop}(Y, 3n_1 + 1, 3n_1 + n_6) \quad ; \quad Z^1 = \text{IP}_2(X_3, Y_3)$
3. $X_4 = \text{Crop}(X, 3n_1 + n_6 + 1, n) \quad ; \quad Y_4 = \text{Crop}(Y, 3n_1 + n_6 + 1, n)$
4. Correlation breaker with advice: $F = 2\text{AdvCB}(Y_4, X_4, Z^1, G)$
5. $X^{a+1} = \text{Crop}(X_4, 4n_x a + 1, 4n_x a + 4n_x)$
6. $S = \text{Ext}_6(X^{a+1}, F)$

Output: S

Algorithm 2 : $2\text{AdvCB} : \{0, 1\}^{n_7} \times \{0, 1\}^{n_7} \times \{0, 1\}^{2h} \times \{0, 1\}^a \rightarrow \{0, 1\}^{\frac{n_y}{8}}$

Input: Y_4, X_4, Z^1, G

1. For $i = 1, 2, \dots, a$:
 2. $Y^i = \text{Crop}(Y_4, 4n_y(i - 1) + 1, 4n_y(i))$
 3. $X^i = \text{Crop}(X_4, 4n_x(i - 1) + 1, 4n_x(i))$
 4. Flip-flop: $Z^{i+1} = 2\text{FF}(Y^i, X^i, Z^i, G_i)$
5. For $i = a + 1, a + 2, \dots, 3a$:
 6. $Y^i = \text{Crop}(Y_4, 4n_y(i - 1) + 1, 4n_y(i))$
 7. $X^i = \text{Crop}(X_4, 4n_x(i - 1) + 1, 4n_x(i))$
8. $F = \text{Ext}_4(Y^{a+1}, Z^{a+1})$

Output: F

Algorithm 3 : $2\text{FF} : \{0, 1\}^{4n_y} \times \{0, 1\}^{4n_x} \times \{0, 1\}^{2h} \times \{0, 1\} \rightarrow \{0, 1\}^{2h}$

Input: Y^i, X^i, Z^i, G_i

$X_j^i = \text{Crop}(X^i, n_x(j-1) + 1, n_x(j))$ for every $j \in \{1, 2, 3, 4\}$

$Y_j^i = \text{Crop}(Y^i, n_y(j-1) + 1, n_y(j))$ for every $j \in \{1, 2, 3, 4\}$

$Z_1^i = \text{Crop}(Z^i, 1, h)$ and $Z_2^i = \text{Crop}(Z^i, h+1, 2h)$

1. $Z_s^i = \text{Prefix}(Z_1^i, s)$, $A^i = \text{Ext}_1(Y_1^i, Z_s^i)$, $C^i = \text{Ext}_2(Z_2^i, A^i)$, $B^i = \text{Ext}_1(Y_2^i, C^i)$
2. If $G_i = 0$ then $\bar{Z}^i = \text{Ext}_3(X_1^i, A^i)$ and if $G_i = 1$ then $\bar{Z}^i = \text{Ext}_3(X_2^i, B^i)$
3. $\bar{Z}_1^i = \text{Crop}(\bar{Z}^i, 1, h)$ and $\bar{Z}_2^i = \text{Crop}(\bar{Z}^i, h+1, 2h)$.
4. $\bar{Z}_s^i = \text{Prefix}(\bar{Z}_1^i, s)$, $\bar{A}^i = \text{Ext}_1(Y_3^i, \bar{Z}_s^i)$, $\bar{C}^i = \text{Ext}_2(\bar{Z}_2^i, \bar{A}^i)$, $\bar{B}^i = \text{Ext}_1(Y_4^i, \bar{C}^i)$
5. If $G_i = 0$, then $O = \text{Ext}_3(X_3^i, \bar{B}^i)$ and if $G_i = 1$, then $O = \text{Ext}_3(X_4^i, \bar{A}^i)$

Output: O

Theorem 6 (Security of new-2nmExt). *Let $\rho_{X\hat{X}X'\hat{X}'NY\hat{Y}Y'\hat{Y}'M}$ be an $(n - n_1, n - n_1)$ -qnm-state with $|X| = |Y| = n$. Then,*

$$\|\rho_{SS'YY'M} - U_{n_x/4} \otimes \rho_{S'YY'M}\|_1 \leq \mathcal{O}(\varepsilon),$$

where $S = \text{new-2nmExt}(X, Y)$ and $S' = \text{new-2nmExt}(X', Y')$.

Proof. The proof proceeds in similar lines to the proof of Theorem 6 in [BJK21] using Fact 20 for alternating extraction argument, Fact 21 for bounding the min-entropy required in alternating extraction, Facts 13, 18 for the security of Inner product function in (k_1, k_2) -qma-state framework, Fact 3 for relation between Δ_B, Δ and we do not repeat it. \square

4.2 Efficiently sampling from the preimage of new-2nmExt

Recall that we showed existence of a quantum secure non-malleable-code where encoding scheme was based on inverting 2nmExt, a quantum secure 2-source non-malleable-extractor. In particular, for any fixed message $S = s$, the encoder, Enc outputs a uniformly random string from the set $2\text{nmExt}^{-1}(s)$. The decoder is the function 2nmExt itself. We call this as the *standard encoding and decoding* based on 2nmExt. We now state the main result of this paper.

Theorem 7 (Main Theorem). *Let $\text{new-2nmExt} : \{0, 1\}^n \times \{0, 1\}^n \rightarrow \{0, 1\}^m$ be the quantum secure 2-source non-malleable-extractor from Algorithm 1, where $m = n_x/4$. Let (Enc, Dec) be the standard encoding and decoding based on new-2nmExt. Let $\hat{S}\text{Enc}(\hat{S}) = \hat{S}\hat{X}\hat{Y}$ for a uniform message $\hat{S} = U_m$. There exists an efficient algorithm that can sample from a distribution $\tilde{S}\tilde{X}\tilde{Y}$ such that $\|\tilde{S}\tilde{X}\tilde{Y} - \hat{S}\hat{X}\hat{Y}\|_1 \leq \mathcal{O}(\varepsilon)$ and $\tilde{S} = U_m$.*

Proof. Consider $XY = U_n \otimes U_n$. Let $S = \text{new-2nmExt}(X, Y)$. From Eq. (7) in the proof of Theorem 5 (after noting $\hat{S}\hat{X}\hat{Y} \equiv (SXY)_\sigma$ in Eq. (7) and $SXY \equiv (SXY)_\theta$ in Eq. (7)), we have

$$\|SXY - \hat{S}\hat{X}\hat{Y}\|_1 \leq \mathcal{O}(\varepsilon). \quad (11)$$

From Claim 5, we have an efficient algorithm that can sample from a distribution $\tilde{S}\tilde{X}\tilde{Y}$ such that

$$\|SXY - \tilde{S}\tilde{X}\tilde{Y}\|_1 \leq \mathcal{O}(\varepsilon) \quad ; \quad \tilde{S} = U_m.$$

From Eq. (11) and using triangle inequality, we have

$$\|\hat{S}\hat{X}\hat{Y} - \tilde{S}\tilde{X}\tilde{Y}\|_1 \leq \mathcal{O}(\varepsilon) \quad ; \quad \tilde{S} = U_m,$$

which completes the proof. \square

Claim 5. Let $2\text{nmExt} : \{0, 1\}^n \times \{0, 1\}^n \rightarrow \{0, 1\}^{n_x/4}$ be the new-2nmExt from Algorithm 1. Let $XY = U_n \otimes U_{n_2}$, $S = 2\text{nmExt}(X, Y)$. We can sample efficiently (in time polynomial in n) from a distribution $(\tilde{X}\tilde{Y}\tilde{S})$ such that

$$\|XYS - \tilde{X}\tilde{Y}\tilde{S}\|_1 \leq \mathcal{O}(\varepsilon) \quad ; \quad \tilde{S} = U_{n_x/4}.$$

Proof. We consider the intermediate random variables while generating $S = \text{new-2nmExt}(X, Y)$ from X, Y . We use the same intermediate random variables but with tilde notation to denote the random variables we sample (in the reverse order). We note that the argument in this proof is entirely classical. Let

$$X_1, Y_1, R, G, X_3, Y_3, X^{[a+1]}, Y^{[a+1]}, X^{[a+2,3a]}, Y^{[a+2,3a]}, S$$

be as defined in Algorithms 1, 2, 3. We use the following sampling strategy:

1. Sample $g = (x_1, \bar{x}_2, y_1, \bar{y}_2) \leftarrow \tilde{G} = G = X_1 \circ \text{ECC}(U_{n_2})_{\text{Samp}(\text{IP}(X_1, Y_1))} \circ Y_1 \circ \text{ECC}(U_{n_2})_{\text{Samp}(\text{IP}(X_1, Y_1))}$,
2. Sample $(x_3, x^{[a+1]}, y_3, y^{[a+1]}, s) \leftarrow \tilde{X}_3 \tilde{X}^{[a+1]} \tilde{Y}_3 \tilde{Y}^{[a+1]} \tilde{S} | (\tilde{G} = g)$ from Claim 7, where $\tilde{S} | (\tilde{G} = g) = U_{n_x/4}$.
3. Sample $(x^{[a+2,3a]}, y^{[a+2,3a]}) \leftarrow \tilde{X}^{[a+2,3a]} \tilde{Y}^{[a+2,3a]} | (\tilde{G} = g, \tilde{X}_3 \tilde{X}^{[a+1]} \tilde{Y}_3 \tilde{Y}^{[a+1]} = x_3 x^{[a+1]} y_3 y^{[a+1]}) = X^{[a+2,3a]} Y^{[a+2,3a]} | (G = g, X_3 X^{[a+1]} Y_3 Y^{[a+1]} = x_3 x^{[a+1]} y_3 y^{[a+1]})$ from Claim 6.

Consider,

$$\begin{aligned} & \|XYS - \tilde{X}\tilde{Y}\tilde{S}\|_1 \\ & \leq \|GXYS - \tilde{G}\tilde{X}\tilde{Y}\tilde{S}\|_1 && \text{(Fact 4)} \\ & \leq \|GX_1 X_3 X^{[a+1]} Y_1 Y_3 Y^{[a+1]} S - \tilde{G} \tilde{X}_1 \tilde{X}_3 \tilde{X}^{[a+1]} \tilde{Y}_1 \tilde{Y}_3 \tilde{Y}^{[a+1]} \tilde{S}\|_1 && \text{(Fact 4, Step (3) and Claim 6)} \\ & \leq \|GX_3 X^{[a+1]} Y_3 Y^{[a+1]} S - \tilde{G} \tilde{X}_3 \tilde{X}^{[a+1]} \tilde{Y}_3 \tilde{Y}^{[a+1]} \tilde{S}\|_1 && \text{(Fact 4)} \\ & = \mathbb{E}_{g \leftarrow G} \|X_3 X^{[a+1]} Y_3 Y^{[a+1]} S | (G = g) - \tilde{X}_3 \tilde{X}^{[a+1]} \tilde{Y}_3 \tilde{Y}^{[a+1]} \tilde{S} | (\tilde{G} = g)\|_1 && \text{(Fact 5 and } \tilde{G} = G) \\ & \leq \mathcal{O}(\varepsilon) && \text{(Claim 7).} \end{aligned}$$

\square

Claim 6. Let $2\text{nmExt} : \{0, 1\}^n \times \{0, 1\}^n \rightarrow \{0, 1\}^{n_x/4}$ be the new-2nmExt from Algorithm 1. Let $XY = U_n \otimes U_n$, $S = 2\text{nmExt}(X, Y)$ and intermediate random variables

$$X_1, Y_1, G, X_3, Y_3, X^{[a]}, Y^{[a]}, X^{[a+1,3a]}, Y^{[a+1,3a]}$$

be as defined in Algorithms 1, 2, 3. Then, we have

$$GX_3Y_3X^{[a+1]}Y^{[a+1]} = G \otimes X_3Y_3X^{[a+1]}Y^{[a+1]}.$$

Furthermore, given $g \in \text{supp}(G)$ and $x_3y_3x^{[a+1]}y^{[a+1]}$, we can efficiently (in time polynomial in n) sample from the distribution $X^{[a+2,3a]}Y^{[a+2,3a]}|(G = g, X_3Y_3X^{[a+1]}Y^{[a+1]} = x_3y_3x^{[a+1]}y^{[a+1]})$.

Proof. Note $X = X_1 \circ X_2$, $Y = Y_1 \circ Y_2$ and $G = X_1 \circ \text{ECC}(X_2)_{\text{Samp}(\text{IP}(X_1, Y_1))} \circ Y_1 \circ \text{ECC}(Y_2)_{\text{Samp}(\text{IP}(X_1, Y_1))}$ from the construction of 2nmExt . Note $X_2Y_2 = U_{n_2} \otimes U_{n_2}$ and for fixed $G = g$, the distribution $X_2Y_2|(G = g) = X_2|(G = g) \otimes Y_2|(G = g)$.

Let $j \in [n_4]$ be such that $\text{Crop}(X_2, 1, j \log(n+1))$ has the string $(X_3, X^{[a+1]})$ as prefix. Thus, $(n_4 - j) \log(n+1) \geq (2a-1)4n_x$. For our choice of parameters, $j < n_4 - n_5$. We now fix $G = g = x_1 \circ \bar{x}_2 \circ y_1 \circ \bar{y}_2$ and let $\mathcal{T}_g = \text{Samp}(\text{IP}(x_1, y_1)) = \{t_1, t_2, \dots, t_{n_5}\}$.

Using Lemma 1, with the following assignment of terms (terms on left are from Lemma 1 and terms on right are from here)

$$(k, q, n, t, \mathcal{S}, \mathcal{Q}, M) \leftarrow (n_4, n+1, n, n_5, \mathcal{T}_g, [j], X_2),$$

we get that $X_2|(G = g)$ restricted to first $j \log(n+1)$ bits is uniform. Thus, $\text{Crop}(X_2|(G = g), 1, j \log(n+1))$ is uniform. This further implies $(X_3, X^{[a+1]}|(G = g)$ is uniform since $(X_3, X^{[a+1]})$ is a prefix of $\text{Crop}(X_2|(G = g), 1, j \log(n+1))$. Also, sampling from $X^{[a+2,3a]}|(G = g, X_3X^{[a+1]} = x_3x^{[a+1]})$ in time polynomial in $(n_4, n+1)$ follows from Lemma 1. Using similar argument one can also note $(Y_3, Y^{[a+1]}|(G = g)$ is uniform and sampling from $Y^{[a+2,3a]}|(G = g, Y_3Y^{[a+1]} = y_3y^{[a+1]})$ can be done in time polynomial in $(n_4, n+1)$. Thus, $GX_3Y_3X^{[a+1]}Y^{[a+1]} = G \otimes X_3Y_3X^{[a+1]}Y^{[a+1]}$ follows since $X_3Y_3X^{[a+1]}Y^{[a+1]}|(G = g) = X_3Y_3X^{[a+1]}Y^{[a+1]} = U_{n_6} \otimes U_{n_6} \otimes U_{(a+1)4n_x} \otimes U_{(a+1)4n_x}$. \square

Claim 7. Let $2\text{nmExt} : \{0, 1\}^n \times \{0, 1\}^n \rightarrow \{0, 1\}^{n_x/4}$ be the new- 2nmExt from Algorithm 1. Let $XY = U_n \otimes U_n$, $S = 2\text{nmExt}(X, Y)$ and

$$X_1, Y_1, R, G, X_3, Y_3, X^{[a]}, Y^{[a]}, Z^{[a]}, A^{[a]}, B^{[a]}, C^{[a]}, \bar{Z}^{[a]}, \bar{A}^{[a]}, \bar{B}^{[a]}, \bar{C}^{[a]}, Z^{a+1}, X^{[a+1,3a]}, Y^{[a+1,3a]}, F, S$$

be as defined in Algorithms 1, 2, 3. For any $g \in \text{supp}(G)$, we can sample efficiently from a distribution $(\tilde{X}_3\tilde{Y}_3\tilde{X}^{[a+1]}\tilde{Y}^{[a+1]}\tilde{S})|G = g$ such that

$$\|(X_3Y_3X^{[a+1]}Y^{[a+1]}S)|(G = g) - (\tilde{X}_3\tilde{Y}_3\tilde{X}^{[a+1]}\tilde{Y}^{[a+1]}\tilde{S})|(G = g)\|_1 \leq \mathcal{O}(\varepsilon) \quad ; \quad \tilde{S}|(G = g) = U_{n_x/4}.$$

Proof. Let $g = g_1g_2 \dots g_a$. Note from Claim 6, we have $GX_3Y_3X^{[a+1]}Y^{[a+1]} = G \otimes X_3Y_3X^{[a+1]}Y^{[a+1]}$. Thus, fixing $G = g$, distribution of sources in the alternating extraction remains the same as before, i.e. exactly uniform.

Suppose $g_a = 1$, we show how to efficiently sample from distribution $(Z^a X^a Y^a X^{a+1} Y^{a+1} S)|(G = g)$ approximately¹⁶. We remove conditioning of $G = g$ for the rest of the proof. From Algorithms 1, 2 and 3, we have

$$Y^a = Y_1^a \circ Y_2^a \circ Y_3^a \circ Y_4^a, \quad X^a = X_1^a \circ X_2^a \circ X_3^a \circ X_4^a \quad \text{and} \quad \{A^a, B^a, C^a, \bar{Z}^a, \bar{A}^a, Z^{a+1}, F, S\}$$

¹⁶Similar argument holds when $g_a = 0$.

as intermediate random variables for $g_a = 1$. From Claim 8, we have $\|\bar{Z}^a - U_{2h}\|_1 \leq \mathcal{O}(a\varepsilon')$. From construction of $2nm\text{Ext}$, we have $\bar{Z}^a Y_3^a Y_4^a X_3^a X_4^a Y^{a+1} X^{a+1} = \bar{Z}^a \otimes Y_3^a \otimes Y_4^a \otimes X_3^a \otimes X_4^a \otimes Y^{a+1} \otimes X^{a+1}$. Thus, we have

$$\|\bar{Z}^a Y_3^a Y_4^a X_3^a X_4^a Y^{a+1} X^{a+1} - U_{2h} \otimes U_{n_y} \otimes U_{n_y} \otimes U_{n_x} \otimes U_{n_x} \otimes U_{4n_y} \otimes U_{4n_x}\|_1 \leq \mathcal{O}(a\varepsilon'). \quad (12)$$

Let us proceed flip-flop procedure (Algorithm 3) with $\hat{Z}^a \hat{Y}_3^a \hat{Y}_4^a \hat{X}_3^a \hat{X}_4^a \hat{Y}^{a+1} \hat{X}^{a+1} = U_{2h} \otimes U_{n_y} \otimes U_{n_y} \otimes U_{n_x} \otimes U_{n_x} \otimes U_{4n_y} \otimes U_{4n_x}$ and denote intermediate random variables as hat variables. Using Fact 4 and Eq. (12), we have

$$\|\bar{Z}^a Y_3^a Y_4^a X_3^a X_4^a Y^{a+1} X^{a+1} \bar{A}^a Z^{a+1} F S - \hat{Z}^a \hat{Y}_3^a \hat{Y}_4^a \hat{X}_3^a \hat{X}_4^a \hat{Y}^{a+1} \hat{X}^{a+1} \hat{A}^a \hat{Z}^{a+1} \hat{F} \hat{S}\|_1 \leq \mathcal{O}(a\varepsilon'). \quad (13)$$

From Algorithms 1, 2, 3, we have

$$(\hat{Z}_s^a \otimes \hat{Y}_3^a) \leftrightarrow (\hat{A}^a \otimes \hat{X}_4^a) \leftrightarrow (\hat{Z}^{a+1} \otimes \hat{Y}^{a+1}) \leftrightarrow (\hat{F} \otimes \hat{X}^{a+1}) \leftrightarrow \hat{S}. \quad (14)$$

Using Corollary 1 and noting $\hat{Z}_s^a \hat{Y}_3^a = U_s \otimes U_{n_y}$, we have, $\|\hat{A}^a - U_b\|_1 \leq \varepsilon'$. Noting $\hat{A}^a \hat{X}_4^a = \hat{A}^a \otimes U_{n_x}$, we further have

$$\|\hat{A}^a \hat{X}_4^a - U_b \otimes U_{n_x}\|_1 \leq \varepsilon'.$$

Using similar arguments, we also get

$$\|\hat{Z}^{a+1} \hat{Y}^{a+1} - U_{2h} \otimes U_{4n_y}\|_1 \leq 2\varepsilon' \quad ; \quad \|\hat{F} \hat{X}^{a+1} - U_{n_y/8} \otimes U_{4n_x}\|_1 \leq 2\varepsilon' + \varepsilon^2.$$

We use the following sampling strategy to sample from a distribution $\tilde{Z}^a \tilde{Y}_3^a \tilde{Y}_4^a \tilde{A}^a \tilde{X}_3^a \tilde{X}_4^a \tilde{Z}^{a+1} \tilde{Y}^{a+1} \tilde{F} \tilde{X}^{a+1} \tilde{S}$:

1. Sample $(\tilde{z}^a, \tilde{a}^a, \tilde{z}^{a+1}, \tilde{f}, \tilde{s}) \leftarrow \tilde{Z}^a \tilde{A}^a \tilde{Z}^{a+1} \tilde{F} \tilde{S} = U_{2h} \otimes U_b \otimes U_{2h} \otimes U_{n_y/8} \otimes U_{n_x/4}$,
2. Sample $\tilde{x}^{a+1} \leftarrow \tilde{X}^{a+1} | (\tilde{F} \tilde{S} = \tilde{f} \tilde{s})$ which is same as $\tilde{x}^{a+1} \leftarrow \{x^{a+1} : \tilde{s} = \text{Ext}_6(x^{a+1}, \tilde{f})\}$,
3. Sample $\tilde{y}^{a+1} \leftarrow \tilde{Y}^{a+1} | (\tilde{Z}^{a+1} \tilde{F} = \tilde{z}^{a+1} \tilde{f})$ which is same as $\tilde{y}^{a+1} \leftarrow \{y^{a+1} : \tilde{f} = \text{Ext}_4(y^{a+1}, \tilde{z}^{a+1})\}$,
4. Sample $\tilde{x}_4^a \leftarrow \tilde{X}_4^a | (\tilde{A}^a \tilde{Z}^{a+1} = \tilde{a}^a \tilde{z}^{a+1})$ which is same as $\tilde{x}_4^a \leftarrow \{x_4^a : \tilde{z}^{a+1} = \text{Ext}_3(x_4^a, \tilde{a}^a)\}$,
5. Sample $\tilde{y}_3^a \leftarrow \tilde{Y}_3^a | (\tilde{Z}_s^a \tilde{A}^a = \tilde{z}_s^a \tilde{a}^a)$ which is same as $\tilde{y}_3^a \leftarrow \{y_3^a : \tilde{a}^a = \text{Ext}_1(y_3^a, \tilde{z}_s^a)\}$,
6. Sample $\tilde{y}_4^a \leftarrow \tilde{Y}_4^a = U_{n_y}$ and independently of $\tilde{Z}^a \tilde{Y}_3^a \tilde{A}^a \tilde{X}_4^a \tilde{Z}^{a+1} \tilde{Y}^{a+1} \tilde{F} \tilde{X}^{a+1} \tilde{S}$,
7. Sample $\tilde{x}_3^a \leftarrow \tilde{X}_3^a = U_{n_x}$ and independently of $\tilde{Z}^a \tilde{Y}_3^a \tilde{Y}_4^a \tilde{A}^a \tilde{X}_4^a \tilde{Z}^{a+1} \tilde{Y}^{a+1} \tilde{F} \tilde{X}^{a+1} \tilde{S}$.

Noting,

$$\|\hat{F} \hat{X}^{a+1} - U_{n_y/8} \otimes U_{4n_x}\|_1 \leq 2\varepsilon' + \varepsilon^2 \quad ; \quad \hat{S} = \text{Ext}_6(\hat{X}^{a+1}, \hat{F})$$

and using Claim 3, with the below assignment of terms (terms on the left are from Claim 3 and on the right are from here),

$$(X, H, O, \tilde{X}, \tilde{H}, \tilde{O}, \varepsilon'') \leftarrow (\hat{X}^{a+1}, \hat{F}, \hat{S}, \tilde{X}^{a+1}, \tilde{F}, \tilde{S}, 0),$$

we get that the sampled distribution $\tilde{F} \tilde{X}^{a+1} \tilde{S}$ satisfies

$$\|\hat{F} \hat{X}^{a+1} \hat{S} - \tilde{F} \tilde{X}^{a+1} \tilde{S}\|_1 \leq 2\varepsilon' + 2\varepsilon^2. \quad (15)$$

Noting,

$$\|\hat{Z}^{a+1}\hat{Y}^{a+1} - U_{2h} \otimes U_{4n_y}\|_1 \leq 2\varepsilon' \quad ; \quad \hat{F} = \text{Ext}_4(\hat{Y}^{a+1}, \hat{Z}^{a+1})$$

and using Claim 3 again, with the below assignment of terms (terms on the left are from Claim 3 and on the right are from here),

$$(X, H, O, \tilde{X}, \tilde{H}, \tilde{O}, \varepsilon'') \leftarrow (\hat{Y}^{a+1}, \hat{Z}^{a+1}, \hat{F}, \tilde{Y}^{a+1}, \tilde{Z}^{a+1}, \tilde{F}, 0),$$

we get that the sampled distribution $\tilde{Z}^{a+1}\tilde{Y}^{a+1}\tilde{F}$ satisfies

$$\|\hat{Z}^{a+1}\hat{Y}^{a+1}\hat{F} - \tilde{Z}^{a+1}\tilde{Y}^{a+1}\tilde{F}\|_1 \leq 2\varepsilon' + \varepsilon^2. \quad (16)$$

Note $\hat{Z}^{a+1}\hat{Y}^{a+1} \leftrightarrow \hat{F} \leftrightarrow \hat{X}^{a+1}\hat{S}$ (from Eq. (14)), $\tilde{Z}^{a+1}\tilde{Y}^{a+1} \leftrightarrow \tilde{F} \leftrightarrow \tilde{X}^{a+1}\tilde{S}$ (from the sampling procedure). Thus, from Eqs. (15), (16) and using Claim 2 with the below assignment of terms (terms on the left are from Claim 2 and on the right are from here),

$$(A, B, C, \tilde{A}, \tilde{B}, \tilde{C}) \leftarrow (\hat{Z}^{a+1}\hat{Y}^{a+1}, \hat{F}, \hat{X}^{a+1}\hat{S}, \tilde{Z}^{a+1}\tilde{Y}^{a+1}, \tilde{F}, \tilde{X}^{a+1}\tilde{S}),$$

we get that the sampled distribution $\tilde{Z}^{a+1}\tilde{Y}^{a+1}\tilde{F}\tilde{X}^{a+1}\tilde{S}$ satisfies

$$\|\hat{Z}^{a+1}\hat{Y}^{a+1}\hat{F}\hat{X}^{a+1}\hat{S} - \tilde{Z}^{a+1}\tilde{Y}^{a+1}\tilde{F}\tilde{X}^{a+1}\tilde{S}\|_1 \leq 6\varepsilon' + 4\varepsilon^2 \leq 6\varepsilon' + 4\varepsilon. \quad (17)$$

Noting,

$$\|\hat{A}^a\hat{X}_4^a - U_b \otimes U_{n_x}\|_1 \leq \varepsilon' \quad ; \quad \hat{Z}^{a+1} = \text{Ext}_3(\hat{X}_4^a, \hat{A}^a)$$

and using Claim 3 again, with the below assignment of terms

$$(X, H, O, \tilde{X}, \tilde{H}, \tilde{O}, \varepsilon'') \leftarrow (\hat{X}_4^a, \hat{A}^a, \hat{Z}^{a+1}, \tilde{X}_4^a, \tilde{A}^a, \tilde{Z}^{a+1}, 0),$$

we get that the sampled distribution $\tilde{A}^a\tilde{X}_4^a\tilde{Z}^{a+1}$ satisfies

$$\|\hat{A}^a\hat{X}_4^a\hat{Z}^{a+1} - \tilde{A}^a\tilde{X}_4^a\tilde{Z}^{a+1}\|_1 \leq 2\varepsilon'. \quad (18)$$

Note $\hat{A}^a\hat{X}_4^a \leftrightarrow \hat{Z}^{a+1} \leftrightarrow \hat{Y}^{a+1}\hat{F}\hat{X}^{a+1}\hat{S}$ (from Eq. (14)) and $\tilde{A}^a\tilde{X}_4^a \leftrightarrow \tilde{Z}^{a+1} \leftrightarrow \tilde{Y}^{a+1}\tilde{F}\tilde{X}^{a+1}\tilde{S}$ (from sampling procedure). Thus, from Eqs. (17), (18) and using Claim 2 with the below assignment of registers

$$(A, B, C, \tilde{A}, \tilde{B}, \tilde{C}) \leftarrow (\hat{A}^a\hat{X}_4^a, \hat{Z}^{a+1}, \hat{Y}^{a+1}\hat{F}\hat{X}^{a+1}\hat{S}, \tilde{A}^a\tilde{X}_4^a, \tilde{Z}^{a+1}, \tilde{Y}^{a+1}\tilde{F}\tilde{X}^{a+1}\tilde{S}),$$

we get that the sampled distribution $\tilde{A}^a\tilde{X}_4^a\tilde{Z}^{a+1}\tilde{Y}^{a+1}\tilde{F}\tilde{X}^{a+1}\tilde{S}$ satisfies

$$\|\hat{A}^a\hat{X}_4^a\hat{Z}^{a+1}\hat{Y}^{a+1}\hat{F}\hat{X}^{a+1}\hat{S} - \tilde{A}^a\tilde{X}_4^a\tilde{Z}^{a+1}\tilde{Y}^{a+1}\tilde{F}\tilde{X}^{a+1}\tilde{S}\|_1 \leq 10\varepsilon' + 4\varepsilon. \quad (19)$$

Proceeding similarly using arguments involving Claim 3, Claim 2 appropriately, the sampled distribution $\tilde{Z}_s^a\tilde{Y}_3^a\tilde{A}^a\tilde{X}_4^a\tilde{Z}^{a+1}\tilde{Y}^{a+1}\tilde{F}\tilde{X}^{a+1}\tilde{S}$ satisfies,

$$\|\hat{Z}_s^a\hat{Y}_3^a\hat{A}^a\hat{X}_4^a\hat{Z}^{a+1}\hat{Y}^{a+1}\hat{F}\hat{X}^{a+1}\hat{S} - \tilde{Z}_s^a\tilde{Y}_3^a\tilde{A}^a\tilde{X}_4^a\tilde{Z}^{a+1}\tilde{Y}^{a+1}\tilde{F}\tilde{X}^{a+1}\tilde{S}\|_1 \leq 12\varepsilon' + 4\varepsilon. \quad (20)$$

Also note registers $\text{Cryp}(\hat{Z}^a, s+1, 2h)\hat{X}_3^a\hat{Y}_4^a = U_{2h-s} \otimes U_{n_x} \otimes U_{n_y}$ and independent of registers $\hat{Z}_s^a\hat{Y}_3^a\hat{A}^a\hat{X}_4^a\hat{Z}^{a+1}\hat{Y}^{a+1}\hat{F}\hat{X}^{a+1}\hat{S}$ (similarly for tilde variables). Thus,

$$\|\hat{Z}_s^a\hat{Y}_3^a\hat{Y}_4^a\hat{A}^a\hat{X}_3^a\hat{X}_4^a\hat{Z}^{a+1}\hat{Y}^{a+1}\hat{F}\hat{X}^{a+1}\hat{S} - \tilde{Z}_s^a\tilde{Y}_3^a\tilde{Y}_4^a\tilde{A}^a\tilde{X}_3^a\tilde{X}_4^a\tilde{Z}^{a+1}\tilde{Y}^{a+1}\tilde{F}\tilde{X}^{a+1}\tilde{S}\|_1 \leq 12\varepsilon' + 4\varepsilon. \quad (21)$$

Using Eqs. (13), (21) and triangle inequality, we get

$$\|\bar{Z}^a Y_3^a Y_4^a \bar{A}^a X_3^a X_4^a Z^{a+1} Y^{a+1} F X^{a+1} S - \tilde{\bar{Z}}^a \tilde{Y}_3^a \tilde{Y}_4^a \tilde{A}^a \tilde{X}_3^a \tilde{X}_4^a \tilde{Z}^{a+1} \tilde{Y}^{a+1} \tilde{F} \tilde{X}^{a+1} \tilde{S}\|_1 \leq \mathcal{O}((a+1)\varepsilon') + 4\varepsilon.$$

Using Fact 4, we further have that the sampled distribution $\tilde{\bar{Z}}^a \tilde{X}_3^a \tilde{X}_4^a \tilde{Y}_3^a \tilde{Y}_4^a \tilde{X}^{a+1} \tilde{Y}^{a+1} \tilde{S}$ satisfies

$$\|\bar{Z}^a X_3^a X_4^a Y_3^a Y_4^a X^{a+1} Y^{a+1} S - \tilde{\bar{Z}}^a \tilde{X}_3^a \tilde{X}_4^a \tilde{Y}_3^a \tilde{Y}_4^a \tilde{X}^{a+1} \tilde{Y}^{a+1} \tilde{S}\|_1 \leq \mathcal{O}((a+1)\varepsilon') + 4\varepsilon. \quad (22)$$

From Claim 8, we have $\|Z^a - U_{2h}\|_1 \leq \mathcal{O}(a\varepsilon')$. From construction of $2nmExt$, we have $Z^a Y_1^a Y_2^a X_1^a X_2^a = Z^a \otimes Y_1^a \otimes Y_2^a \otimes X_1^a \otimes X_2^a$. Thus, we have

$$\|Z^a Y_1^a Y_2^a X_1^a X_2^a - U_{2h} \otimes U_{n_y} \otimes U_{n_y} \otimes U_{n_x} \otimes U_{n_x}\|_1 \leq \mathcal{O}(a\varepsilon'). \quad (23)$$

Proceed flip-flop procedure with $\hat{Z}^a \hat{X}_1^a \hat{X}_2^a \hat{Y}_1^a \hat{Y}_2^a = U_{2h} \otimes U_{n_x} \otimes U_{n_x} \otimes U_{n_y} \otimes U_{n_y}$ and denote intermediate random variables as hat variables. Using Fact 4 and Eq. (23), we have

$$\|Z^a Y_1^a Y_2^a X_1^a X_2^a A^a C^a B^a \bar{Z}^a - \hat{Z}^a \hat{Y}_1^a \hat{Y}_2^a \hat{X}_1^a \hat{X}_2^a \hat{A}^a \hat{C}^a \hat{B}^a \hat{\bar{Z}}^a\|_1 \leq \mathcal{O}(a\varepsilon'). \quad (24)$$

From Algorithms 1, 2, 3, we have

$$(\hat{Z}_s^a \otimes \hat{Y}_1^a) \leftrightarrow (\hat{A}^a \otimes \hat{Z}_2^a) \leftrightarrow (\hat{C}^a \otimes \hat{Y}_2^a) \leftrightarrow (\hat{B}^a \otimes \hat{X}_2^a) \leftrightarrow \hat{Z}^a. \quad (25)$$

We extend the sampling procedure in the following way: consider sampled $\tilde{\bar{z}}^a \leftarrow \tilde{\bar{Z}}^a = U_{2h}$ (from before), next sample $\tilde{b}^a \leftarrow \tilde{B}^a = U_b$ and independently and proceed to sample from $\tilde{X}_2^a | (\tilde{\bar{Z}}^a \tilde{B}^a = \tilde{\bar{z}}^a \tilde{b}^a)$. Using similar arguments involving Corollary 1, Claim 3, Claim 2 like before (in this proof), we can sample from a distribution $\tilde{Z}^a \tilde{Y}_1^a \tilde{Y}_2^a \tilde{X}_1^a \tilde{X}_2^a \tilde{A}^a \tilde{C}^a \tilde{B}^a \tilde{\bar{Z}}^a$ such that

$$\|\hat{Z}^a \hat{Y}_1^a \hat{Y}_2^a \hat{X}_1^a \hat{X}_2^a \hat{A}^a \hat{C}^a \hat{B}^a \hat{\bar{Z}}^a - \tilde{Z}^a \tilde{Y}_1^a \tilde{Y}_2^a \tilde{X}_1^a \tilde{X}_2^a \tilde{A}^a \tilde{C}^a \tilde{B}^a \tilde{\bar{Z}}^a\|_1 \leq \mathcal{O}(\varepsilon'). \quad (26)$$

Using Eq. (26) along with Fact 4 we have,

$$\|\tilde{\bar{Z}}^a - U_{2h}\|_1 \leq \mathcal{O}(\varepsilon'). \quad (27)$$

From Eqs. (24), (26) and triangle inequality, we have

$$\|Z^a Y_1^a Y_2^a X_1^a X_2^a A^a C^a B^a \bar{Z}^a - \tilde{Z}^a \tilde{Y}_1^a \tilde{Y}_2^a \tilde{X}_1^a \tilde{X}_2^a \tilde{A}^a \tilde{C}^a \tilde{B}^a \tilde{\bar{Z}}^a\|_1 \leq \mathcal{O}((a+1)\varepsilon'). \quad (28)$$

Using Fact 4, we further can sample from a distribution $\tilde{Z}^a \tilde{Y}_1^a \tilde{Y}_2^a \tilde{X}_1^a \tilde{X}_2^a \tilde{\bar{Z}}^a$ such that

$$\|Z^a Y_1^a Y_2^a X_1^a X_2^a \bar{Z}^a - \tilde{Z}^a \tilde{Y}_1^a \tilde{Y}_2^a \tilde{X}_1^a \tilde{X}_2^a \tilde{\bar{Z}}^a\|_1 \leq \mathcal{O}((a+1)\varepsilon'). \quad (29)$$

Note that $Z^a Y_1^a Y_2^a X_1^a X_2^a \leftrightarrow \bar{Z}^a \leftrightarrow X_3^a X_4^a Y_3^a Y_4^a X^{a+1} Y^{a+1} S$ (from construction of $2nmExt$) and $\tilde{Z}^a \tilde{Y}_1^a \tilde{Y}_2^a \tilde{X}_1^a \tilde{X}_2^a \leftrightarrow \tilde{\bar{Z}}^a \leftrightarrow \tilde{X}_3^a \tilde{X}_4^a \tilde{Y}_3^a \tilde{Y}_4^a \tilde{X}^{a+1} \tilde{Y}^{a+1} \tilde{S}$ (from sampling procedure). From Eqs. (22), (29) and using Claim 2 along with Fact 4, we have

$$\|Z^a Y^{[a,a+1]} X^{[a,a+1]} S - \tilde{Z}^a \tilde{Y}^{[a,a+1]} \tilde{X}^{[a,a+1]} \tilde{S}\|_1 \leq \mathcal{O}((a+1)\varepsilon') + 4\varepsilon.$$

We extend the sampling procedure now considering sampled $\tilde{z}^a \leftarrow \tilde{\bar{Z}}^a$ (from before) such that $\|\tilde{\bar{Z}}^a - U_{2h}\|_1 \leq \mathcal{O}(\varepsilon')$ (from Eq. (27)) and proceed depending on bit g_{a-1} . Proceeding likewise

depending on $g = g_1 g_2 \dots g_a$ and inductively using similar arguments involving Corollary 1, Claim 3, Claim 2 along with Fact 4, we can sample from $\tilde{X}_3 \tilde{Y}_3 \tilde{X}^{[a+1]} \tilde{Y}^{[a+1]} \tilde{S}$ such that

$$\|X_3 Y_3 X^{[a+1]} Y^{[a+1]} S - \tilde{X}_3 \tilde{Y}_3 \tilde{X}^{[a+1]} \tilde{Y}^{[a+1]} \tilde{S}\|_1 \leq \mathcal{O}(\varepsilon') + \left(\sum_{i=1}^a \mathcal{O}((a+1)\varepsilon') \right) + 4\varepsilon = \mathcal{O}(\varepsilon).$$

□

We show a claim that states that intermediate random variables in the alternating extraction are approximately uniform even conditioned on every $G = g$.

Claim 8. *Let $2\text{nmExt} : \{0, 1\}^n \times \{0, 1\}^n \rightarrow \{0, 1\}^{n_x/4}$ be the new- 2nmExt from Algorithm 1. Let $XY = U_n \otimes U_n$, $S = 2\text{nmExt}(X, Y)$ and set*

$$\mathbb{P} \stackrel{\text{def}}{=} \{G, Z^{[a]}, A^{[a]}, B^{[a]}, C^{[a]}, \bar{Z}^{[a]}, \bar{A}^{[a]}, \bar{B}^{[a]}, \bar{C}^{[a]}, Z^{a+1}\}$$

be the intermediate random variables as defined in Algorithms 1, 2, 3. Then, we have for any random variable $Q \in \mathbb{P} \setminus \{G\}$ and any fixing $G = g$,

$$\|Q|(G = g) - U_{|Q|}\|_1 \leq \mathcal{O}(a\varepsilon').$$

Proof. From Claim 6, we have

$$GX_3 Y_3 X^{[a+1]} Y^{[a+1]} = G \otimes X_3 Y_3 X^{[a+1]} Y^{[a+1]},$$

where $X = X_1 \circ X_3 \circ X^{[a+1]} \circ X^{[a+2, 3a]}$ and $Y = Y_1 \circ Y_3 \circ Y^{[a+1]} \circ Y^{[a+2, 3a]}$. Also, note from Algorithms 1, 2, 3, any random variable $Q \in \mathbb{P} \setminus \{G\}$ is extracted from sources $X_3 Y_3 X^{[a+1]} Y^{[a+1]}$. Note for any $i \in [a]$ and i -th flip-flop procedure (Algorithm 3), intermediate random variables $\{A^i, B^i, C^i, \bar{Z}^i, \bar{A}^i, \bar{B}^i, \bar{C}^i, Z^{i+1}\}$ are extracted from $X^i Y^i Z^i = X^i \otimes Y^i \otimes Z^i$. We remove conditioning on $G = g$ for the random variables for the rest of the proof.

Since $Z^1 = \text{IP}(X_3, Y_3)$, using Fact 14 we have $\|Z^1 - U_{2h}\|_1 \leq 2^{-\Omega(n)} \leq \varepsilon'$. We show if for any round i , $\|Z^i - U_{2h}\|_1 \leq \mathcal{O}(i\varepsilon')$, then for any $Q \in \{A^i, B^i, C^i, \bar{Z}^i, \bar{A}^i, \bar{B}^i, \bar{C}^i, Z^{i+1}\}$ we have $\|Q - U_{|Q|}\|_1 \leq \mathcal{O}((i+2)\varepsilon')$.

We denote generated intermediate random variables A^i, B^i, C^i, \bar{Z}^i from $\hat{Z}^i = \hat{Z}_1^i \hat{Z}_2^i = U_{2h}$ instead of Z^i as hat random variables. Using Fact 4 repeatedly, we have

$$\|X_1^i X_2^i Y_1^i Y_2^i Z^i A^i B^i C^i \bar{Z}^i - X_1^i X_2^i Y_1^i Y_2^i \hat{Z}^i \hat{A}^i \hat{B}^i \hat{C}^i \hat{\bar{Z}}^i\|_1 \leq \mathcal{O}(i\varepsilon'). \quad (30)$$

Since $\hat{A}^i = \text{Ext}_1(Y_1^i, \hat{Z}_s^i)$, $Y_1^i \hat{Z}_s^i = U_{n_y} \otimes U_s$, using Corollary 1 we have

$$\|\hat{A}^i - U_b\|_1 \leq \varepsilon'. \quad (31)$$

Since $\hat{C}^i = \text{Ext}_2(\hat{Z}_2^i, \hat{A}^i)$, $\hat{Z}_2^i \hat{A}^i = U_h \otimes \hat{A}^i$ and $\|\hat{A}^i - U_b\|_1 \leq \varepsilon'$, using Corollary 1 we have

$$\|\hat{C}^i - U_s\|_1 \leq 2\varepsilon'. \quad (32)$$

Since $\hat{B}^i = \text{Ext}_1(Y_2^i, \hat{C}^i)$, $Y_2^i \hat{C}^i = U_{n_y} \otimes \hat{C}^i$ and $\|\hat{C}^i - U_s\|_1 \leq 2\varepsilon'$, using Corollary 1 we have

$$\|\hat{B}^i - U_b\|_1 \leq 3\varepsilon'. \quad (33)$$

If $g_i = 1$, we have $\hat{Z}^i = \text{Ext}_1(X_2^i, \hat{B}^i)$, $X_2^i \hat{B}^i = U_{n_x} \otimes \hat{B}^i$ and $\|\hat{B}^i - U_b\|_1 \leq 3\varepsilon'$. Using Corollary 1, we further have

$$\|\hat{Z}^i - U_{2h}\|_1 \leq 4\varepsilon'. \quad (34)$$

Similarly, if $g_i = 0$, we will have

$$\|\hat{Z}^i - U_{2h}\|_1 \leq 2\varepsilon'. \quad (35)$$

Using Fact 4, Eqs. (30), (31), (32), (33), (34) and (35) along with appropriate triangle inequalities, for any $Q \in \{A^i, B^i, C^i, Z^i\}$ we have $\|Q - U_{|Q|}\|_1 \leq \mathcal{O}((i+1)\varepsilon')$. Using similar arguments and noting $X_3^i X_4^i Y_3^i Y_4^i Z^i = X_3^i \otimes X_4^i \otimes Y_3^i \otimes Y_4^i \otimes Z^i$, one can note for any $Q \in \{\bar{A}^i, \bar{B}^i, \bar{C}^i, Z^{i+1}\}$ we have $\|Q - U_{|Q|}\|_1 \leq \mathcal{O}((i+2)\varepsilon')$. Thus, since we have a rounds of flip-flop procedure, the desired follows from induction argument. \square

Acknowledgment

We thank Divesh Aggarwal and Maciej Obremski for introducing us to the problem, sharing their insights on the classical constructions and several other helpful discussions. We also thank Upendra Kapshikar for the helpful discussions.

This work is supported by the National Research Foundation, including under NRF RF Award No. NRF-NRFF2013-13, the Prime Minister's Office, Singapore and the Ministry of Education, Singapore, under the Research Centres of Excellence program and by Grant No. MOE2012-T3-1-009 and in part by the NRF2017-NRF-ANR004 VanQuTe Grant.

References

- [ABJO21] Divesh Aggarwal, Naresh Goud Boddu, Rahul Jain, and Maciej Obremski. Quantum measurement adversary, 2021. ArXiv:2106.02766.
- [ADL18] Divesh Aggarwal, Yevgeniy Dodis, and Shachar Lovett. Non-malleable codes from additive combinatorics. *SIAM Journal on Computing*, 47(2):524–546, 2018.
- [ADN⁺19] Divesh Aggarwal, Ivan Damgård, Jesper Buus Nielsen, Maciej Obremski, Erick Purwanto, João Ribeiro, and Mark Simkin. Stronger leakage-resilient and non-malleable secret sharing schemes for general access structures. In Alexandra Boldyreva and Daniele Micciancio, editors, *Advances in Cryptology – CRYPTO 2019*, pages 510–539, Cham, 2019. Springer International Publishing.
- [Agg15] Divesh Aggarwal. Affine-evasive sets modulo a prime. *Inf. Process. Lett.*, 115(2):382–385, February 2015.
- [AO20] D. Aggarwal and M. Obremski. A constant rate non-malleable code in the split-state model. In *2020 IEEE 61st Annual Symposium on Foundations of Computer Science (FOCS)*, pages 1285–1294, Los Alamitos, CA, USA, nov 2020. IEEE Computer Society.
- [Bel64] J. S. Bell. On the einstein podolsky rosen paradox. *Physics Physique Fizika*, 1:195–200, Nov 1964.

- [BJK21] Naresh Goud Boddu, Rahul Jain, and Upendra Kapshikar. Quantum secure non-malleable-extractors, 2021.
- [BW92] Charles H. Bennett and Stephen J. Wiesner. Communication via one- and two-particle operators on einstein-podolsky-rosen states. *Phys. Rev. Lett.*, 69:2881–2884, Nov 1992.
- [CG14] Mahdi Cheraghchi and Venkatesan Guruswami. Non-malleable coding against bit-wise and split-state tampering. In *Proceedings of Theory of Cryptography Conference (TCC)*, pages 440–464, 2014. Extended version in *Journal of Cryptology*.
- [CG16] Mahdi Cheraghchi and Venkatesan Guruswami. Capacity of non-malleable codes. *IEEE Transactions on Information Theory*, 62(3):1097–1118, 2016.
- [CGL20] Eshan Chattopadhyay, Vipul Goyal, and Xin Li. Nonmalleable extractors and codes, with their many tampered extensions. *SIAM Journal on Computing*, 49(5):999–1040, 2020.
- [CLW14] Kai-Min Chung, Xin Li, and Xiaodi Wu. Multi-source randomness extractors against quantum side information, and their applications. *CoRR*, abs/1411.2315, 2014.
- [Coh15] Gil Cohen. Local correlation breakers and applications to three-source extractors and mergers. In *2015 IEEE 56th Annual Symposium on Foundations of Computer Science*, pages 845–862, 2015.
- [Coh16] Gil Cohen. Non-Malleable Extractors - New Tools and Improved Constructions. In Ran Raz, editor, *31st Conference on Computational Complexity (CCC 2016)*, volume 50 of *Leibniz International Proceedings in Informatics (LIPIcs)*, pages 8:1–8:29, Dagstuhl, Germany, 2016. Schloss Dagstuhl–Leibniz-Zentrum fuer Informatik.
- [CV17] Gil Cohen and Thomas Vidick. Privacy amplification against active quantum adversaries. ArXiv:1608.06318, 2017.
- [Dat09] Nilanjana Datta. Min- and max- relative entropies and a new entanglement monotone. *IEEE Transactions on Information Theory*, 55:2816–2826, 2009.
- [DKO13] Stefan Dziembowski, Tomasz Kazana, and Maciej Obremski. Non-malleable codes from two-source extractors. In Ran Canetti and Juan A. Garay, editors, *Advances in Cryptology – CRYPTO 2013*, pages 239–257, Berlin, Heidelberg, 2013. Springer Berlin Heidelberg.
- [DPVR12] Anindya De, Christopher Portmann, Thomas Vidick, and Renato Renner. Trevisan’s extractor in the presence of quantum side information. *SIAM Journal on Computing*, 41(4):915–940, 2012.
- [DPW18] Stefan Dziembowski, Krzysztof Pietrzak, and Daniel Wichs. Non-malleable codes. *J. ACM*, 65(4), April 2018.
- [FvdG06] C. A. Fuchs and J. van de Graaf. Cryptographic distinguishability measures for quantum-mechanical states. *IEEE Trans. Inf. Theor.*, 45(4):1216–1227, September 2006.
- [GK18a] Vipul Goyal and Ashutosh Kumar. Non-malleable secret sharing. *Cryptology ePrint Archive*, Report 2018/316, 2018. <https://ia.cr/2018/316>.

- [GK18b] Vipul Goyal and Ashutosh Kumar. Non-malleable secret sharing for general access structures. Cryptology ePrint Archive, Report 2018/750, 2018. <https://ia.cr/2018/750>.
- [GPR16] Vipul Goyal, Omkant Pandey, and Silas Richelson. Textbook non-malleable commitments. In *Proceedings of the Forty-Eighth Annual ACM Symposium on Theory of Computing*, STOC '16, page 1128–1141, New York, NY, USA, 2016. Association for Computing Machinery.
- [JRS02] R. Jain, J. Radhakrishnan, and P. Sen. Privacy and interaction in quantum communication complexity and a theorem about the relative entropy of quantum states. In *The 43rd Annual IEEE Symposium on Foundations of Computer Science, 2002. Proceedings.*, pages 429–438, 2002.
- [Li15] X. Li. Three-source extractors for polylogarithmic min-entropy. In *2015 IEEE 56th Annual Symposium on Foundations of Computer Science*, pages 863–882, 2015.
- [Li17] Xin Li. Improved non-malleable extractors, non-malleable codes and independent source extractors. In *Proceedings of the 49th Annual ACM SIGACT Symposium on Theory of Computing*, STOC 2017, page 1144–1156, New York, NY, USA, 2017. Association for Computing Machinery.
- [Li19] Xin Li. Non-malleable extractors and non-malleable codes: Partially optimal constructions. In *Proceedings of the 34th Computational Complexity Conference, CCC '19*, Dagstuhl, DEU, 2019. Schloss Dagstuhl–Leibniz-Zentrum fuer Informatik.
- [LL12] Feng-Hao Liu and Anna Lysyanskaya. Tamper and leakage resilience in the split-state model. In Reihaneh Safavi-Naini and Ran Canetti, editors, *Advances in Cryptology – CRYPTO 2012*, pages 517–532, Berlin, Heidelberg, 2012. Springer Berlin Heidelberg.
- [NC00] Michael A. Nielsen and Isaac L. Chuang. *Quantum computation and quantum information*. Cambridge University Press, Cambridge, UK, 2000.
- [SV19] Akshayaram Srinivasan and Prashant Nalini Vasudevan. Leakage resilient secret sharing and applications. In Alexandra Boldyreva and Daniele Micciancio, editors, *Advances in Cryptology – CRYPTO 2019*, pages 480–509, Cham, 2019. Springer International Publishing.
- [Uhl76] A. Uhlmann. The "transition probability" in the state space of a *-algebra. *Rep. Math. Phys.*, 9:273–279, 1976.
- [Wat11] John Watrous. Chapter 5, naimark's theorem; characterizations of channels. Lecture notes on Theory of Quantum Information, 2011.

A A quantum secure one-many non-malleable-code in the split-state model

A.1 Preliminaries for quantum secure one-many non-malleable-code in the split-state model

Let m, n, k, t be positive integers and $\varepsilon, \varepsilon' > 0$. Let \mathcal{F} denote the set of all the functions from $\{0, 1\}^n \rightarrow \{0, 1\}^n$. We next define $\text{copy}^{(t)} : \{0, 1\}^* \times \{0, 1\}^* \rightarrow \{0, 1\}^*$ when the first input is a t -tuple as follows: $\text{copy}^{(t)}((x_1, x_2, \dots, x_t), s) = (\text{copy}(x_1, s), \text{copy}(x_2, s), \dots, \text{copy}(x_t, s))$, where the function $\text{copy} : \{0, 1\}^* \times \{0, 1\}^* \rightarrow \{0, 1\}^*$ is such that $\text{copy}(x, s) = s$ if $x = \text{same}$, otherwise $\text{copy}(x, s) = x$.

Definition 13 (One-many non-malleable-codes in the split-state model [CGL20]). *A standard encoding and decoding scheme (Enc, Dec) (see Definition 1) with message length m and block length n is a $(t; m, n, \varepsilon)$ -non-malleable-code with respect to a family of tampering functions $(\mathcal{F} \times \mathcal{F})^t$, if for every*

$$f = ((g_1, h_1), (g_2, h_2), \dots, (g_t, h_t)) \in (\mathcal{F} \times \mathcal{F})^t,$$

there exists a random variable $\mathcal{D}_f = \mathcal{D}_{((g_1, h_1), (g_2, h_2), \dots, (g_t, h_t))}$ on $(\{0, 1\}^m \cup \{\text{same}\})^t$ which is independent of the randomness in Enc such that for all messages $s \in \{0, 1\}^m$, it holds that

$$\|\text{Dec}((g_1, h_1)(\text{Enc}(s))) \dots \text{Dec}((g_t, h_t)(\text{Enc}(s))) - \text{copy}^{(t)}(\mathcal{D}_f, s)\|_1 \leq \varepsilon.$$

Definition 14 ($(t; k_1, k_2)$ -qnm-state [BJK21]). *Let $\sigma_{X\hat{X}NMY\hat{Y}}$ be a (k_1, k_2) -qma-state. Let $U : \mathcal{H}_X \otimes \mathcal{H}_N \rightarrow \mathcal{H}_X \otimes \mathcal{H}_{X^{[t]}} \otimes \mathcal{H}_{\hat{X}^{[t]}} \otimes \mathcal{H}_{N'}$ and $V : \mathcal{H}_Y \otimes \mathcal{H}_M \rightarrow \mathcal{H}_Y \otimes \mathcal{H}_{Y^{[t]}} \otimes \mathcal{H}_{\hat{Y}^{[t]}} \otimes \mathcal{H}_{M'}$ be isometries such that for $\rho = (U \otimes V)\sigma(U \otimes V)^\dagger$, we have $X^{[t]}Y^{[t]}$ classical (with copy $\hat{X}^{[t]}\hat{Y}^{[t]}$) and*

$$\forall i \in [t], \Pr(Y \neq Y^i)_\rho = 1 \quad \text{or} \quad \Pr(X \neq X^i)_\rho = 1.$$

We call ρ a $(t; k_1, k_2)$ -qnm-state.

Definition 15 (Quantum secure 2-source t -non-malleable-extractor [BJK21]). *An (n, n, m) -non-malleable-extractor t -2nmExt : $\{0, 1\}^n \times \{0, 1\}^n \rightarrow \{0, 1\}^m$ is $(t; k_1, k_2, \varepsilon)$ -secure against qnm-adv if for every $(t; k_1, k_2)$ -qnm-state ρ (chosen by the adversary qnm-adv),*

$$\|\rho_{t\text{-2nmExt}(X, Y) t\text{-2nmExt}(X^1, Y^1) \dots t\text{-2nmExt}(X^t, Y^t) X X^{[t]} N' - U_m \otimes \rho_{t\text{-2nmExt}(X^1, Y^1) \dots t\text{-2nmExt}(X^t, Y^t) X X^{[t]} N'}\|_1 \leq \varepsilon,$$

and

$$\|\rho_{t\text{-2nmExt}(X, Y) t\text{-2nmExt}(X^1, Y^1) \dots t\text{-2nmExt}(X^t, Y^t) Y Y^{[t]} M' - U_m \otimes \rho_{t\text{-2nmExt}(X^1, Y^1) \dots t\text{-2nmExt}(X^t, Y^t) Y Y^{[t]} M'}\|_1 \leq \varepsilon.$$

Definition 16 (Quantum one-many split-state adversary). *Let message $S = U_m$, (Enc, Dec) be a standard encoding and decoding scheme in the split-state model (see Definition 1) and $(X, Y) = \text{Enc}(S)$. Let σ_{SXY} be the state after encoding message S . The quantum one-many split-state adversary (denoted $\mathcal{A} = (U, V, \psi)$) will act via two isometries, (U, V) using an additional shared entangled state $|\psi\rangle_{NM}$ as specified by $U : \mathcal{H}_X \otimes \mathcal{H}_N \rightarrow \mathcal{H}_{X^{[t]}} \otimes \mathcal{H}_{N'}$ and $V : \mathcal{H}_Y \otimes \mathcal{H}_M \rightarrow \mathcal{H}_{Y^{[t]}} \otimes \mathcal{H}_{M'}$. Let $\hat{\rho} = (U \otimes V)(\sigma \otimes |\psi\rangle\langle\psi|)(U \otimes V)^\dagger$ and ρ be the final state after measuring the registers $(X^{[t]}Y^{[t]})$ in the computational basis¹⁷.*

¹⁷We enforce the quantum split-state adversary to return classical registers $X^{[t]}, Y^{[t]}$ by doing the measurement in the computational basis. This is without any loss of generality since the decoding process can start by doing the measurement (this will not affect anything in the absence of quantum one-many split-state adversary) and then decode using Dec .

Definition 17 (Quantum secure one-many non-malleable-codes in the split-state model). A standard encoding and decoding scheme (Enc, Dec) (see Definition 1) with message length m and block length n is a $(t; m, n, \varepsilon)$ -quantum secure one-many non-malleable-code in the split-state model with error ε , if for state ρ and adversary $\mathcal{A} = (U, V, \psi)$ (as defined in Definition 16), there exists a random variable $\mathcal{D}_{\mathcal{A}}$ on $(\{0, 1\}^m \cup \{\text{same}\})^t$ such that

$$\|\rho_{S^{\text{Dec}}(X^1, Y^1) \dots \text{Dec}(X^t, Y^t)} - Z^{\text{copy}}(t)(\mathcal{D}_{\mathcal{A}}, Z)\|_1 \leq \varepsilon,$$

where $Z = U_m$.

Claim 9. Let $\sigma_{X\hat{X}NY\hat{Y}M}$ be a (k_1, k_2) -qma-state with $|X| = n$ and $|Y| = n$. Let $t\text{-}2\text{nmExt} : \{0, 1\}^n \times \{0, 1\}^n \rightarrow \{0, 1\}^m$ be a $(t; k_1, k_2, \varepsilon)$ -quantum secure 2-source t -non-malleable-extractor. Let $S = t\text{-}2\text{nmExt}(X, Y)$. Then,

$$\|\sigma_{SYM} - U_m \otimes \sigma_{YM}\|_1 \leq \varepsilon.$$

Proof. Let $U : \mathcal{H}_X \rightarrow \mathcal{H}_X \otimes \mathcal{H}_{X^{[t]}} \otimes \mathcal{H}_{\hat{X}^{[t]}}$, $V : \mathcal{H}_Y \rightarrow \mathcal{H}_Y \otimes \mathcal{H}_{Y^{[t]}} \otimes \mathcal{H}_{\hat{Y}^{[t]}}$ be isometries such that for $\rho = (U \otimes V)\sigma(U \otimes V)^\dagger$, we have $X^{[t]}Y^{[t]}$ classical (with copies $\hat{X}^{[t]}\hat{Y}^{[t]}$ respectively) and for every $i \in [t]$ either $\Pr(X \neq X^i)_\rho = 1$ or $\Pr(Y \neq Y^i)_\rho = 1$.¹⁸ Notice the state ρ is a $(t; k_1, k_2)$ -qnm-state. Since $t\text{-}2\text{nmExt}$ is a $(t; k_1, k_2, \varepsilon)$ -quantum secure (see Definition 15), we have

$$\|\rho_{SS^{[t]}Y^{[t]}M} - U_m \otimes \rho_{S^{[t]}Y^{[t]}M}\|_1 \leq \varepsilon,$$

where $S^i = t\text{-}2\text{nmExt}(X^i, Y^i)$. Using Fact 4, we get

$$\|\rho_{SYM} - U_m \otimes \rho_{YM}\|_1 \leq \varepsilon.$$

The desired now follows by noting $\sigma_{XNMY} = \rho_{XNMY}$. \square

Claim 10. Let $t\text{-}2\text{nmExt} : \{0, 1\}^n \times \{0, 1\}^n \rightarrow \{0, 1\}^m$ be a $(t; k_1, k_2, \varepsilon)$ -quantum secure 2-source t -non-malleable-extractor. Then, $t\text{-}2\text{nmExt}$ is also a $(j; k_1, k_2, \varepsilon)$ -quantum secure 2-source j -non-malleable-extractor for any positive integer $j \leq t$.

Proof. Let $\sigma_{X\hat{X}NY\hat{Y}M}$ be a (k_1, k_2) -qma-state with $|X| = n$ and $|Y| = n$. Let $U : \mathcal{H}_X \otimes \mathcal{H}_N \rightarrow \mathcal{H}_X \otimes \mathcal{H}_{X^{[j]}} \otimes \mathcal{H}_{\hat{X}^{[j]}} \otimes \mathcal{H}_{N'}$, $V : \mathcal{H}_Y \otimes \mathcal{H}_M \rightarrow \mathcal{H}_Y \otimes \mathcal{H}_{Y^{[j]}} \otimes \mathcal{H}_{\hat{Y}^{[j]}} \otimes \mathcal{H}_{M'}$ be isometries such that for $\rho = (U \otimes V)\sigma(U \otimes V)^\dagger$, we have $X^{[j]}Y^{[j]}$ classical (with copies $\hat{X}^{[j]}\hat{Y}^{[j]}$ respectively) and for every $i \in [j]$ either $\Pr(X \neq X^i)_\rho = 1$ or $\Pr(Y \neq Y^i)_\rho = 1$. Notice the state ρ is a $(j; k_1, k_2)$ -qnm-state.

Let $U' : \mathcal{H}_X \rightarrow \mathcal{H}_X \otimes \mathcal{H}_{X^{[t]\setminus[j]}} \otimes \mathcal{H}_{\hat{X}^{[t]\setminus[j]}}$, $V' : \mathcal{H}_Y \rightarrow \mathcal{H}_Y \otimes \mathcal{H}_{Y^{[t]\setminus[j]}} \otimes \mathcal{H}_{\hat{Y}^{[t]\setminus[j]}}$ be isometries¹⁹ such that for $\rho' = (U' \otimes V')\rho(U' \otimes V')^\dagger$, we have $X^{[t]\setminus[j]}Y^{[t]\setminus[j]}$ classical (with copies $\hat{X}^{[t]\setminus[j]}\hat{Y}^{[t]\setminus[j]}$ respectively) and for every $i \in [t]$ either $\Pr(X \neq X^i)_{\rho'} = 1$ or $\Pr(Y \neq Y^i)_{\rho'} = 1$. Notice the state ρ' is a $(t; k_1, k_2)$ -qnm-state. Since $t\text{-}2\text{nmExt}$ is a $(t; k_1, k_2, \varepsilon)$ -quantum secure (see Definition 15), we have

$$\|\rho'_{SS^{[t]}XX^{[t]}M'} - U_m \otimes \rho'_{S^{[t]}XX^{[t]}M'}\|_1 \leq \varepsilon \quad ; \quad \|\rho'_{SS^{[t]}YY^{[t]}M'} - U_m \otimes \rho'_{S^{[t]}YY^{[t]}M'}\|_1 \leq \varepsilon,$$

where $S^i = t\text{-}2\text{nmExt}(X^i, Y^i)$. Using Fact 4, we get

$$\|\rho'_{SS^{[j]}XX^{[j]}M'} - U_m \otimes \rho'_{S^{[j]}XX^{[j]}M'}\|_1 \leq \varepsilon \quad ; \quad \|\rho'_{SS^{[j]}YY^{[j]}M'} - U_m \otimes \rho'_{S^{[j]}YY^{[j]}M'}\|_1 \leq \varepsilon.$$

¹⁸It is easily seen that such isometries exists.

¹⁹It is easily seen that such isometries exists.

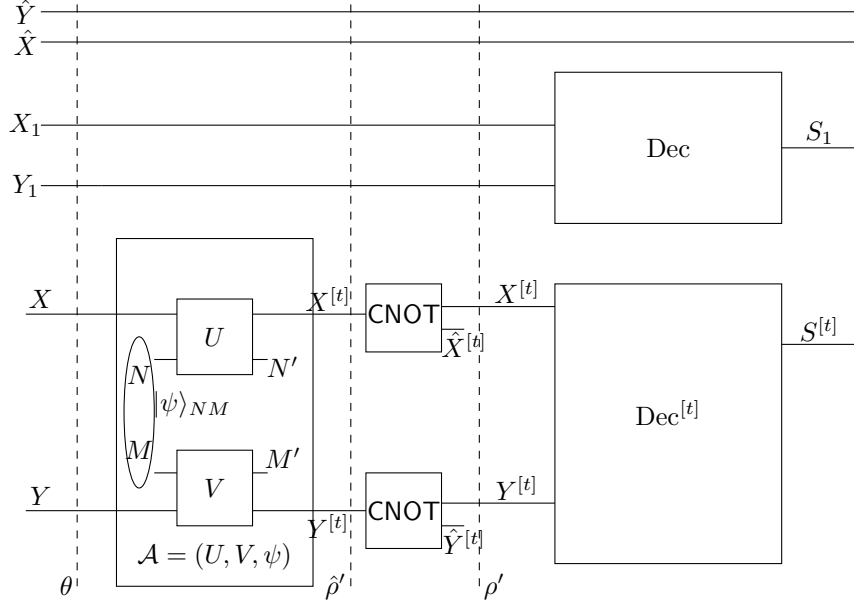

Figure 3:

Noting $\rho'_{XX^{[t]}N'M'YY^{[t]}} = \rho_{XX^{[t]}N'M'YY^{[t]}}$, we finally get

$$\|\rho_{SS^{[t]}XX^{[t]}M'} - U_m \otimes \rho_{S^{[t]}XX^{[t]}M'}\|_1 \leq \varepsilon \quad ; \quad \|\rho_{SS^{[t]}YY^{[t]}M'} - U_m \otimes \rho_{S^{[t]}YY^{[t]}M'}\|_1 \leq \varepsilon.$$

□

Theorem 8 (Quantum secure one-many non-malleable-code in the split-state model). *Let $t\text{-}2\text{nmExt} : \{0, 1\}^n \times \{0, 1\}^n \rightarrow \{0, 1\}^m$ be a $(t; n - k, n - k, \varepsilon)$ -quantum secure 2-source t -non-malleable-extractor. There exists a $(t; m, n, \varepsilon')$ -quantum secure one-many non-malleable-code with parameter $\varepsilon' = (2^{-k} + \varepsilon)2^{2t} + \varepsilon$.*

Proof. The proof proceeds in similar lines of Theorem 5. We do not repeat the entire argument but provide the necessary details required to complete the proof.

Let $\mathcal{A} = (U, V, \psi)$ be the quantum split-state adversary from Definition 16. We show that the standard encoding based on $t\text{-}2\text{nmExt}$ is a $(t; m, n, \varepsilon')$ -quantum secure one-many non-malleable-code. Using arguments similar to Theorem 5, it suffices to prove

$$\|\rho'_{S_1 S^{[t]}} - U_m \text{copy}^{(t)}(\mathcal{D}_{\mathcal{A}}, U_m)\|_1 \leq (2^{-k} + \varepsilon)2^{2t},$$

where ρ' is the pure state as in Figure 3 after the action of adversary \mathcal{A} on state θ . Note $S^i = t\text{-}2\text{nmExt}(X^i, Y^i)$ and state $\theta_{X\hat{X}X_1Y\hat{Y}Y_1} = \theta_{X\hat{X}X_1} \otimes \theta_{Y\hat{Y}Y_1}$ is a pure state such that $\theta_X = \theta_Y = U_n$, (X_1, \hat{X}) are copies of X , (Y_1, \hat{Y}) are copies of Y respectively.²⁰ In the Figure 3, with some abuse of notation, we used $\text{Dec}^{[t]}$ to denote $\text{Dec}(X^i, Y^i) = S^i$ performed for every $i \in [t]$.

²⁰It is easily seen such state exists.

Let ρ' be the final pure state after we generate t -bit classical registers C, D (with copies \hat{C}, \hat{D} respectively) such that $C_i = 1$ indicates $X_1 \neq X^i$ in state ρ' and $D_i = 1$ indicates $Y_1 \neq Y^i$ in state ρ' for every $i \in [t]$.

Using similar arguments as in Theorem 5, one can note that the state ρ' is an (n, n) -qma-state. For $C = c \in \{0, 1\}^t, D = d \in \{0, 1\}^t$, denote $\mathcal{S}^{c,d} = \{i \in [t] : (c_i = 1) \vee (d_i = 1)\}$ and $\rho'^{c,d} = \rho' | ((C, D) = (c, d))$. For every $c, d \in \{0, 1\}^t$, let $\mathcal{D}_{\mathcal{A}}^{c,d} = \mathcal{D}_{(U,V,\psi)}^{c,d} = (\mathcal{D}_{\mathcal{A},1}^{c,d}, \dots, \mathcal{D}_{\mathcal{A},t}^{c,d})$, where $\mathcal{D}_{\mathcal{A},j}^{c,d} = \rho'_{t-2nm\text{Ext}(X^j, Y^j)}^{c,d}$ for $j \in \mathcal{S}^{c,d}$ and $\mathcal{D}_{\mathcal{A},j}^{c,d}$ be the distribution that is deterministically equal to same otherwise. Let $\mathcal{D}_{\mathcal{A}} = \sum_{c,d \in \{0,1\}^t} \Pr((C, D) = (c, d))_{\rho'} \mathcal{D}_{\mathcal{A}}^{c,d}$. Note for every $c, d \in \{0, 1\}^t$, the value $\Pr((C, D) = (c, d))_{\rho'}$ depends only on (U, V, ψ) . Note

$$\rho'_{S_1 S^{[t]}} = \sum_{c,d \in \{0,1\}^t} \Pr((C, D) = (c, d))_{\rho'} \rho'_{S_1 S^{[t]}}^{c,d}, \quad (36)$$

and

$$\text{Zcopy}^{(t)}(\mathcal{D}_{\mathcal{A}}, Z) = \sum_{c,d \in \{0,1\}^t} \Pr((C, D) = (c, d))_{\rho'} \text{Zcopy}^{(t)}(\mathcal{D}_{\mathcal{A}}^{c,d}, Z), \quad (37)$$

where $Z = U_m$.

Claim 11. For every $c, d \in \{0, 1\}^t$, we have

$$\Pr((C, D) = (c, d))_{\rho'} \|\rho'_{S_1 S^{[t]}}^{c,d} - \text{Zcopy}^{(t)}(\mathcal{D}_{\mathcal{A}}^{c,d}, Z)\|_1 \leq 2^{-k} + \varepsilon,$$

where $Z = U_m$.

Proof. Fix $c, d \in \{0, 1\}^t$. Suppose $\Pr((C, D) = (c, d))_{\rho'} \leq 2^{-k}$, then we are done. Thus we assume otherwise. Note $\mathcal{S}^{c,d}$ is empty only when $(c, d) = (0^t, 0^t)$.

First let $\mathcal{S}^{c,d} = \{i_1, \dots, i_j\}$ be non-empty. Using arguments similar to Claim 4 involving Fact 16 and noting that state ρ' is an (n, n) -qma-state, we get that $\rho'^{c,d}$ is a $(j; n-k, n-k)$ -qnm-state. Using Claim 10 to note $t-2nm\text{Ext}$ is also $(j; n-k, n-k, \varepsilon)$ -quantum secure for any positive integer $j \leq t$ and using Fact 4, we have

$$\|\rho'_{S_1 S^{i_1} \dots S^{i_j}}^{c,d} - U_m \otimes \rho'_{S_1 S^{i_1} \dots S^{i_j}}^{c,d}\|_1 \leq \varepsilon. \quad (38)$$

For any $p \in [t] \setminus \mathcal{S}^{c,d}$, we have $\rho'_{S_1^p}^{c,d} = \rho'_{S^p}^{c,d}$. Thus from Eq. (38) and using Fact 4, we have

$$\|\rho'_{S_1 S^{[t]}}^{c,d} - \text{Zcopy}^{(t)}(\mathcal{D}_{\mathcal{A}}^{c,d}, Z)\|_1 \leq \varepsilon.$$

For $(c, d) = (0^t, 0^t)$, the proof follows noting $\rho'^{c,d}$ is an $(n-k, n-k)$ -qma-state and using Claim 9 along with Fact 4. \square

Consider,

$$\begin{aligned} & \|\rho'_{S_1 S^{[t]}} - \text{Zcopy}^{(t)}(\mathcal{D}_{\mathcal{A}}, Z)\|_1 \\ &= \left\| \sum_{c,d \in \{0,1\}^t} \Pr((C, D) = (c, d))_{\rho'} \rho'_{S_1 S^{[t]}}^{c,d} - \text{Zcopy}^{(t)}(\mathcal{D}_{\mathcal{A}}, Z) \right\|_1 \quad (\text{Eq. (36)}) \\ &\leq \sum_{c,d \in \{0,1\}^t} \Pr((C, D) = (c, d))_{\rho'} \|\rho'_{S_1 S^{[t]}}^{c,d} - \text{Zcopy}^{(t)}(\mathcal{D}_{\mathcal{A}}^{c,d}, Z)\|_1 \quad (\text{Eq. (37) and Fact 6}) \\ &\leq (2^{-k} + \varepsilon) 2^{2t} \quad (\text{Claim 11}). \end{aligned}$$

This completes the proof. \square

A.2 A quantum secure modified 2-source t -non-malleable-extractor

We modify the construction of t -2nmExt from [BJK21], using ideas from [CGL20] to construct a new- t -2nmExt : $\{0, 1\}^n \times \{0, 1\}^n \rightarrow \{0, 1\}^m$ that is $(n - n_1, n - n_1, \mathcal{O}(\varepsilon))$ -secure against qnm-adv for parameters $n_1 = n^{\Omega(1)}$, $m = n^{1-\Omega(1)}$, $t = n^{\Omega(1)}$ and $\varepsilon = 2^{-n^{\Omega(1)}}$.

Parameters

Let $\delta, \delta_1, \delta_2, \delta_3 > 0$ be small enough constants such that $\delta_1 < \delta_2$. Let $n, n_1, n_2, n_3, n_4, n_5, n_6, n_7, n_x, n_y, a, s, b, h, t$ be positive integers and $\varepsilon', \varepsilon > 0$ such that:

$$n_1 = n^{\delta_2} \quad ; \quad n_2 = n - 3n_1 \quad ; \quad q = 2^{\log(n+1)} \quad ; \quad \varepsilon = 2^{-\mathcal{O}(n^{\delta_1})} \quad ;$$

$$n_3 = \frac{n_1}{10} \quad ; \quad n_4 = \frac{n_2}{\log(n+1)} \quad ; \quad n_5 = n^{\delta_2/3} \quad ; \quad a = 6n_1 + 2n_5 \log(n+1) = \mathcal{O}(n_1) \quad ;$$

$$n_6 = 3n_1^3 \quad ; \quad n_7 = n - 3n_1 - n_6 \quad ; \quad n_x = \frac{n_7}{12a} \quad ; \quad n_y = \frac{n_7}{12a} \quad ; \quad 2^{\mathcal{O}(a)}\sqrt{\varepsilon'} = \varepsilon \quad ;$$

$$s = \mathcal{O}\left(\log^2\left(\frac{n}{\varepsilon'}\right)\log n\right) \quad ; \quad b = \mathcal{O}\left(\log^2\left(\frac{n}{\varepsilon'}\right)\log n\right) \quad ; \quad t \leq n^{\delta_3} \quad ; \quad h = 10ts$$

- IP₁ be $\text{IP}_{2^{n_3}}^{3n_1/n_3}$,
- Ext₁ be $(2b, \varepsilon')$ -quantum secure (n_y, s, b) -extractor,
- Ext₂ be $(2s, \varepsilon')$ -quantum secure (h, b, s) -extractor,
- Ext₃ be $(4h, \varepsilon')$ -quantum secure $(n_x, b, 2h)$ -extractor,
- Ext₄ be $(n_y/4t, \varepsilon^2)$ -quantum secure $(4n_y, 2h, n_y/8t)$ -extractor,
- IP₂ be $\text{IP}_{2^{2h}}^{3n_1^3/2h}$,
- Ext₆ be $(\frac{n_x}{2t}, \varepsilon^2)$ -quantum secure $(4n_x, n_y/8t, n_x/4t)$ -extractor.

Definition of 2-source t -non-malleable-extractor

The following theorem shows that the function new- t -2nmExt as defined in Algorithm 4 is $(t; n - n_1, n - n_1, \mathcal{O}(\varepsilon))$ -secure against qnm-adv by noting that $S = \text{new-}t\text{-}2\text{nmExt}(X, Y)$ and $S^i = \text{new-}t\text{-}2\text{nmExt}(X^i, Y^i)$ for every $i \in [t]$. Note that 2AdvCB in Algorithm 4 is same as the one in Algorithm 2 except for parameters and extractors which are to be used as mentioned in this section.

Theorem 9 (Security of new- t -2nmExt). *Let $\rho_{XX^{[t]}\hat{X}\hat{X}^{[t]}NY^{[t]}\hat{Y}\hat{Y}^{[t]}M}$ be a $(t; n - n_1, n - n_1)$ -qnm-state. Then,*

$$\|\rho_{SS^{[t]}YY^{[t]}M} - U_{n_x/4t} \otimes \rho_{S^{[t]}YY^{[t]}M}\|_1 \leq \mathcal{O}(\varepsilon).$$

Proof. The proof proceeds in similar lines to the proof of Theorem 9 in [BJK21] using Fact 20 for alternating extraction argument, Fact 21 for bounding the min-entropy required in alternating extraction and Facts 13, 18 for the security of Inner product function in (k_1, k_2) -qma-state framework, Fact 3 for relation between Δ_B, Δ and we do not repeat it. \square

Algorithm 4 : $\text{new-}t\text{-}2\text{nmExt} : \{0, 1\}^n \times \{0, 1\}^n \rightarrow \{0, 1\}^{n_x/4t}$

Input: X, Y

1. Advice generator:

$$X_1 = \text{Crop}(X, 1, 3n_1) \quad ; \quad Y_1 = \text{Crop}(Y, 1, 3n_1) \quad ; \quad R = \text{IP}_1(X_1, Y_1) \quad ;$$

$$X_2 = \text{Crop}(X, 3n_1 + 1, n) \quad ; \quad Y_2 = \text{Crop}(Y, 3n_1 + 1, n) \quad ;$$

$$G = X_1 \circ \bar{X}_2 \circ Y_1 \circ \bar{Y}_2 = X_1 \circ \text{ECC}(X_2)_{\text{Samp}(R)} \circ Y_1 \circ \text{ECC}(Y_2)_{\text{Samp}(R)}$$

2. $X_3 = \text{Crop}(X, 3n_1 + 1, 3n_1 + n_6) \quad ; \quad Y_3 = \text{Crop}(Y, 3n_1 + 1, 3n_1 + n_6) \quad ; \quad Z^1 = \text{IP}_2(X_3, Y_3)$

3. $X_4 = \text{Crop}(X, 3n_1 + n_6 + 1, n) \quad ; \quad Y_4 = \text{Crop}(Y, 3n_1 + n_6 + 1, n)$

4. Correlation breaker with advice: $F = 2\text{AdvCB}(Y_4, X_4, Z^1, G)$

5. $X^{a+1} = \text{Crop}(X_4, 4n_x a + 1, 4n_x a + 4n_x)$

6. $S = \text{Ext}_6(X^{a+1}, F)$

Output: S

Efficiently sampling from the preimage of $\text{new-}t\text{-}2\text{nmExt}$

Theorem 10. *Let $\text{new-}t\text{-}2\text{nmExt} : \{0, 1\}^n \times \{0, 1\}^n \rightarrow \{0, 1\}^{n_x/4t}$ be the 2-source t -non-malleable-extractor from Algorithm 4. Let (Enc, Dec) be the standard encoding and decoding based on $\text{new-}t\text{-}2\text{nmExt}$. Let $\hat{S}\text{Enc}(\hat{S}) = \hat{S}\hat{X}\hat{Y}$ for a uniform message $\hat{S} = U_{n_x/4t}$. There exists an efficient algorithm that can sample from a distribution $\tilde{S}\tilde{X}\tilde{Y}$ such that $\|\tilde{S}\tilde{X}\tilde{Y} - \hat{S}\hat{X}\hat{Y}\|_1 \leq \mathcal{O}(\varepsilon)$ and $\tilde{S} = U_{n_x/4t}$.*

Proof. The proof follows similarly to that of Theorem 7 and we do not repeat it. □