

# Bifrost: Secure, Scalable and Efficient File Sharing System Using Dual Deduplication

Hadi Sehat<sup>1</sup>, Elena Pagnin<sup>2</sup>, Daniel E. Lucani<sup>1</sup>

<sup>1</sup>Agile Cloud Lab, Department of Electrical and Computer Engineering, DIGIT, Aarhus University, Aarhus, Denmark

<sup>2</sup> Department of Electrical and Information Technology, Lund University, Lund, Sweden

{hadi,daniel.lucani}@ece.au.dk,elena.pagnin@eit.lth.se

**Abstract**—We consider the problem of sharing sensitive or valuable files across users while partially relying on a common, untrusted third-party, e.g., a Cloud Storage Provider (CSP). Although users can rely on a secure peer-to-peer (P2P) channel for file sharing, this introduces potential delay on the data transfer and requires the sender to remain active and connected while the transfer process occurs. Instead of using the P2P channel for the entire file, users can upload information about the file on a common CSP and share only the essential information that enables the receiver to download and recover the original file. This paper introduces Bifrost, an innovative file sharing system inspired by recent results on *dual deduplication*. Bifrost achieves the desired functionality and simultaneously guarantees that (1) the CSP can efficiently compress outsourced data; (2) the secure P2P channel is used only to transmit short, but crucial information; (3) users can check for data integrity, i.e., detect if the CSP alters the outsourced data; and (4) only the sender (data owner) and the intended receiver can access the file after sharing, i.e., the cloud or no malicious adversary can infer useful information about the shared file. We analyze compression and bandwidth performance using a proof-of-concept implementation. Our experiments show that secure file sharing can be achieved by sending only 650 bits on the P2P channel, irrespective of file size, while the CSP that aids the sharing can enjoy a compression rate of 86.9 %.

## I. INTRODUCTION

Secure file sharing between multiple devices has been a major research topic in recent years. Existing approaches tend to offer efficient solutions, especially in settings where the sharing process is aided by a cloud storage system. However, this setting inherently raises a number of privacy and security concerns on users' outsourced data. In particular, if no protection mechanism is put in place, users' data is leaked to the cloud, to an adversary that gains access to the cloud, or to malicious actors monitoring the transmission channel. A traditional method to mitigate such threats is to encrypt the data, upload the ciphertext to the cloud, and send the key required to decrypt the data using a private secret channel between the two users. While this simple solution works for users' privacy, it affects the performance of the cloud aiding in the file sharing procedure. Handling ciphertext rather than plaintext data prevents the cloud from efficiently store data. Intuitively, this is due to the fact that encrypted data is designed to look uniformly random, thus, preventing any compression potential.

In this work, we propose a secure file sharing system that relies on a Dual Deduplication (DD) mechanism. In brief, the authors of [1] developed the concept of DD, which allows

users to transform their input data into a compression-friendly data fragment, and a short recovery fragment that should be kept private by the user. The compression-friendly piece is outsourced to the cloud, and protects the privacy of the user by introducing uncertainty on the original data. This uncertainty is produced by using information-theoretical mechanisms to hide information in the process of generating the outsourced data. The protocol was named Yggdrasil [1]. Our approach is inspired by Yggdrasil and aims at transferring information among clients. We name our system Bifrost, like the burning rainbow bridge that connects Midgard (Earth) and Asgard (the realm of the Gods). Being a secure DD mechanism, Yggdrasil focuses on balancing data privacy and data compression. However, it does not guarantee data integrity, a central feature in file sharing.

### A. Data Deduplication and Yggdrasil

Before we discuss Bifrost and our contributions, we take a look into the aspect of data deduplication and how it is implemented in Yggdrasil to reduce the fingerprint of data on a cloud storage system. Data deduplication was introduced in [2] as a technique to reduce the data fingerprint by removing the identical chunks of data. In a deduplication-based storage system, a file is divided into multiple chunks of a pre-defined fixed length. When the storage identifies a duplicate chunk among the chunks of files in the data, it does not store the chunk as a whole, but a pointer to its duplicate counterpart. These techniques work on redundancy between chunks as opposed to compression that works on redundancy within a chunk [3]. Fig. 2 shows an illustrative example of Deduplication, where a file  $F$  is divided into four chunks  $A, B, C$  and  $A$ , in this case, the deduplication algorithm remove the duplicate chunk  $A$ .

Although data deduplication is an effective method to reduce the fingerprint of the data, it can not identify and remove similar chunks from the data. Therefore, an alternative approach was proposed in [4], called Generalized Deduplication (GD). In this method, the chunks are transformed using a transformation technique into a base and a small deviation pair. The base is used for deduplication while the deviation indicates the difference between the original chunk and the generated base. This transformation is performed in a way to ensure mapping of multiple chunks into a single base, improving the deduplication potential, while having a small

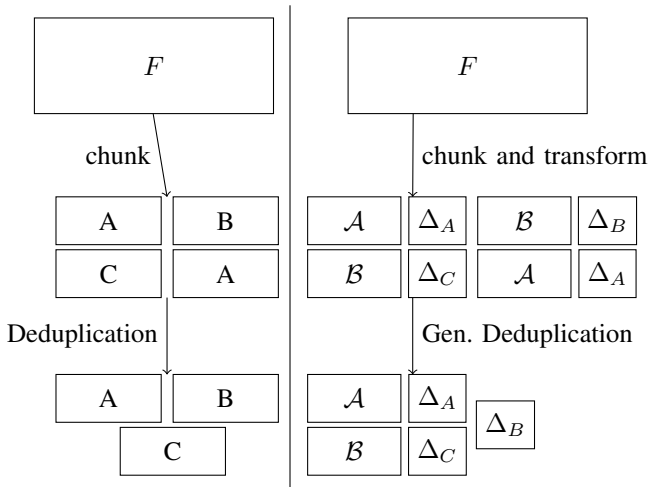

Fig. 2. An illustration of Deduplication and Generalized Deduplication in a storage system.

deviation that has a low impact on the storage requirements. In the current state-of-the-art GD implementations, the used transformation techniques include Hamming codes [4], Reed-Solomon Codes [5] and edit operations such as deletion and swap [1]. Fig. 2 shows a high level example of GD on the same file with the same set of chunks, where both chunks  $B$  and  $C$  are transformed into the same base  $B$ .

DD uses the aspect of GD to provide privacy for a client that wants to store data on a cloud storage system that performs deduplication. The idea behind DD is the fact that without the exact knowledge on the deviation, the original chunk cannot be constructed directly from the base. Therefore, in DD, the client performs the transformation, creating base and deviation, and sends the base to the cloud, while storing the deviation locally, hiding its components from the cloud. In general, in DD, both client and cloud engage by applying transformations on the data. The goal of the client is to provide privacy by creating a small deviation that is stored locally, and the goal of the cloud is to apply deduplication on the received data from the clients. In Yggdrasil in particular, the transformation

that is performed on the client is deletion of symbols. The idea behind this transformation comes from the aspect of deletion channel [6], which is proven to be a hard problem. As a general overview, the client in Yggdrasil deletes some elements from each chunk, creating a base with a size less than the original chunk, and storing the position and value of the deleted elements in the deviation. The base is sent to the cloud, where other edit operations, namely swap and change value, are used for generalized deduplication of the received bases. More details about Yggdrasil and its performance can be found in [1]. Fig. 1 shows a high level view of the transformations performed in a dual deduplication system.

### B. Contribution

Our main contribution is the design and development the first secure file sharing system based on dual deduplication. Concretely, we build on Yggdrasil [1] and construct Bifrost, a scalable and efficient solution for P2P, server-aided secure file sharing. In addition to the transformations performed by Yggdrasil, Bifrost employs a Hash-Based Message Authentication Code (HMAC) to generate an integrity tag on the original input data. This HMAC is used to authenticate the file, and mitigates the effect of an untrusted CSP altering the outsourced data and preventing the receiving party from recovering the correct file. To reduce the amount of data required to be sent using the secure P2P channel, the client encrypts the local secret piece using a symmetric encryption scheme and sends the encrypted secret piece to the cloud. This ensures that as long as the encryption scheme is secure, the cloud cannot learn useful information about the original data, while it can perform efficient compression on a major portion of the data, which is generated by using Yggdrasil. To share a file with another user or device, the data owner needs only to share the HMAC key used to authenticate the file, and the secret keys required to decrypt the HMAC and the secret piece.

More specifically, our contributions are the following:

- We formalize a system model and a threat model for file sharing using the DD paradigm.
- We design Bifrost, our realization of a secure, scalable and efficient file sharing system using DD.

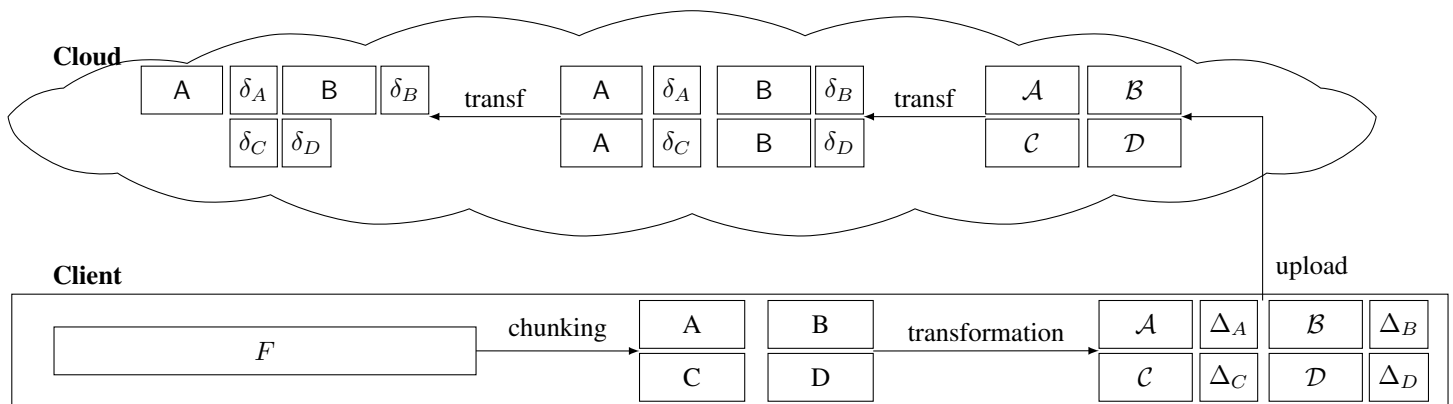

Fig. 1. An illustration of a dual deduplication system.

- We develop a proof-of-concept implementation of Bifrost and analyze its performance in terms of compression rate, provided privacy and required transmission in the P2P channel.
- We demonstrate experimentally that Bifrost realizes secure file sharing between users using a cloud storage by sending only 650 bits, regardless of the size of the data. Moreover, we show that Bifrost achieves a compression rate of 86.9%, while providing computational security against an untrusted cloud.

In the following, we first take a look at some related work in terms of both secure file sharing in an untrusted environment and DD in Section II, then we introduce the system model and performance metrics in Section III. We follow by introducing Bifrost and a step-by-step illustration of the protocol in Section IV. We then analyze the privacy of Bifrost in Section V, followed by simulation results in Section VI. Finally, we conclude in Section VII.

## II. RELATED WORK

As Bifrost is a secure file sharing system using an untrusted cloud, and is proposed based on DD, it is natural to look at the current literature about both these topics. As far as our knowledge, there is no work that has combined the aspects of secure file sharing and DD until now. Therefore, in this Section, we look at some of the state-of-the-art research on the topics that are the main focus point of Bifrost.

### A. Secure File Sharing

Secure file sharing using an untrusted cloud has been a long-known research topic, especially as providing secure file sharing would introduce a large amount of overhead to the cloud, the clients or both [7]. One of the earliest scalable file sharing systems using an untrusted server was Plutus [7], which proposed a scalable file sharing system in the presence of an untrusted cloud. Since then, this research area has focused on multiple aspects of secure file sharing, such as dynamic permission and revocation of read/write rights [8], group-based permissions and access to encrypted files [9], reducing the overhead on the cloud by fixing the number of ciphertexts for each file [10], and allowing deduplication on the ciphertexts [11]. As a noteworthy recent research output, SeGShare [12] uses enclaves and trusted execution environments to achieve promising results in terms of scalability and throughput.

The closest related work in this area are the research focused on providing deduplication on the cloud. However, the major research output on this topic [9], [11]–[13], use deterministic content-derived encryption which uses keys derived from the content in order to encrypt the data. Although this method has provable security at the moment, the security assumptions for these algorithms might not hold in the future, where the security of these methods will become questionable. In contrast, in Bifrost, we argue for privacy against an untrusted cloud while using any form of encryption on the client.

Therefore, Bifrost can be implemented with any encryption method, depending on the use case and desired privacy.

### B. Security for Deduplication

Implementing deduplication for untrusted cloud storage or cloud sharing system has been studied as providing privacy alongside deduplication. There have been multiple works in this area, all of which can be categorized under one of the three approaches of convergence encryption [14], multi-key revealing encryption (MKRE) [15], and DD [1]. Convergence encryption is a message leaked encryption [16] method that ensures privacy against untrusted cloud while providing deduplication on identical chunks. Convergence Encryption can be seen as a random Oracle with consistent output, i.e., identical plaintexts always produce identical ciphertexts [17]. MKRE is an encryption method to provide generalized deduplication on the cloud while providing computational privacy proven in the form of random oracle. DD is a relatively new technique proposed to provide information-theoretic privacy against an honest cloud, while allowing for deduplication or generalized deduplication to be performed on the data on the cloud. In DD, instead of encrypting the file, the client uses information-theoretic tools, such as deletion to introduce uncertainty for an adversary that wishes to reconstruct the original data of the clients.

## III. SYSTEM MODEL AND PERFORMANCE METRICS

Our system consists of a cloud storage, referred to as Cloud, and multiple devices, referred to as Clients. Clients have data that they outsource to the Cloud in order to both reduce storage demands on their end and enable secure and lightweight file sharing among clients. In this work, *data* refers to a collection of files. Each file  $F$  is viewed as a string of  $s_F$  bits, consisting of  $n_F$  symbols of  $k$  size each. Obviously, we have  $s_F = n_F \cdot k$ . After performing transformations in the Client, we generate an outsource piece  $G$  and a secret piece  $D$ .  $G$  is a string consisting of  $n_G$  symbols, where  $n_G < n_F$ , and therefore has a size of  $s_G = n_G \cdot k$ .  $D$  is the secret piece that contains the information about the transformations performed in the client.  $D$  has a size of  $s_d$ . We assume that the channel between Clients and Cloud as well as the P2P channel between Clients are error-free. We assume that the P2P channel cannot be infiltrated by the adversary.

The adversary  $\mathcal{A}$  in our system is an untrusted Cloud, and any malicious Client that is able to access the data stored in the Cloud. We aim to provide privacy against this adversary in two ways: 1) Using transformations on the Client data, which result in a high uncertainty for the adversary on what the original data was, providing privacy for the data. 2) Mitigating the possibility of changing the data stored on the Cloud by the adversary. We assume that both Clients that engage in the file sharing protocol are honest, and therefore follow the protocol exactly. We also note that we want to achieve privacy for Client's data while providing sufficient compression capabilities for the Cloud.

We analyze the performance of our proposed method (Bifrost) using three different metrics: 1) The compression rate on the Cloud. 2) The required transmission in the P2P channel. 3) The privacy against an untrusted Cloud.

The compression ratio on the Cloud denotes the required size to store the received data after compression, compared to the size of the original data. The size of the original data, i.e.,  $DB$  is denoted by  $|DB|$ . In order to define the compression ratio, we need to define two parameters: 1)  $|size|$  denotes the required size to store all the received  $G$  and  $E$  in the Cloud after compression. 2)  $s_{fid}$  denotes the size of the file identifier for each set of  $(G, E)$  sent to the Cloud.

The compression ratio on the Cloud is then:

**Compression ratio:**

$$C = \frac{|size| + f \cdot s_{fid}}{|DB|}, \quad (1)$$

where  $f$  is the number of files in  $DB$ .

The required transmission rate is equal to the size of the data that the Clients need to share in the secure P2P channel. As mentioned, this information consists of three components. 1) The HMAC of file  $M(F)$ , that acts also as the file identifier and has the size of  $s_{fid}$ . 2) The secret key required to generate HMAC from file, i.e.,  $K'$ . 3) The secret key required to decrypt  $E$ , i.e.,  $K$ .

Therefore, the total amount of required transmission for each file is equal to

**Compression ratio:**

$$T(F) = s_{fid} + |K'| + |K|, \quad (2)$$

where  $|x|$  denote the size of component  $x$ .

For the privacy of Bifrost, we use the notion of random oracle model in order to prove the privacy of Bifrost. We argue that in Bifrost, a computationally bounded untrusted Cloud does not gain any information about the original file of Clients. We prove the privacy of Bifrost in full details in Section V.

#### IV. Bifrost: OUR SECURE FILE SHARING SOLUTION

In this Section, we describe Bifrost. First, we discuss how the data is uploaded from the Client to the Cloud, and then we illustrate the transmissions required between two Clients. We refer to the Client that wants to share its data as Sender, and the receiving Client as Receiver. Fig. 3 shows an illustration of the steps taken by each party, and the communications between different parties of the system. We go through these steps in two subsections, first on uploading data from the Sender to the Cloud and then on the sharing of information from Sender to Receiver and downloading the data from the Cloud by the Receiver.

##### A. Uploading data from Client to Cloud

This stage consists of actions from two entities, the Client and the Cloud. When a Client wants to store a file  $F$  in the Cloud, (1) it uses a set of transformations TRANSF to create an outsourced data  $G$  and a deviation  $D$ . This transformation TRANSF includes deletion of symbols from

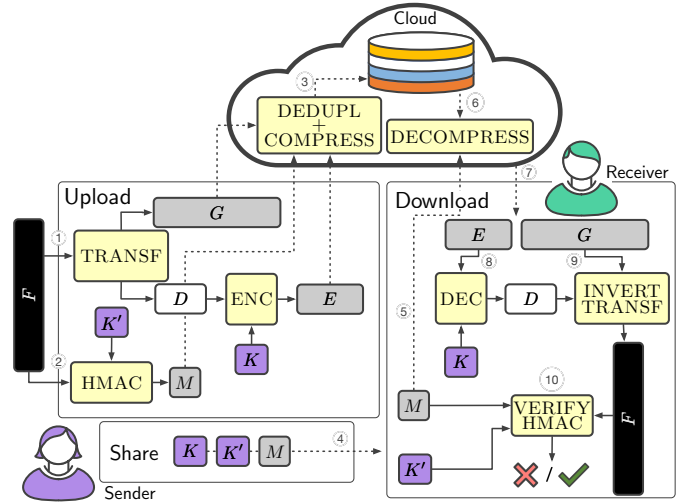

Fig. 3. A graphic representation of the information flow and the main procedures in Bifrost.

the file  $F$ . These deletions are performed using a Pseudo-Random Number Generator (PRNG), and mimics the function of a deletion channel to provide privacy for the Client's data [1]. The deleted symbols are identified by using a seeded PRNG, which outputs  $\alpha = s_F - s_G$  random numbers between 0 and  $s_F - 1$ , pointing to the position of the symbols in  $F$  that are to be deleted. To give an intuition, Fig. 4 shows an example of TRANSF performed on a file  $F$  consisting of 10 symbols of 4 bits each. In this particular example, The Client deletes 2 symbols. The numbers generated by the seeded PRNG are 5 and 3. The Client deletes the symbols in positions 5 and 3, which are 11 and 2, Generating  $G$ ; as well as storing the seed used to create the positions, alongside the value of the deleted symbols in  $D$ . The Client is able to regenerate  $F$  from  $G$  and  $D$  by creating the position of the stored value using the same PRNG and the random seed stored in  $D$ , and simply inserting the values into their respective positions.

(2) The Client then computes the HMAC of the  $F$  using a HMAC function with a secret key  $K'$  to generate  $M = \text{HMAC}(F)$ . This value is used as the file identifier in Bifrost, as is sent to the Cloud, as well as stored locally. The purpose of  $M$  is to provide data integrity against a malicious cloud. Any authentication code can be used as HMAC in order to derive  $M$ . We note that the larger is the size of  $M$ , the stronger privacy is preserved against the adversary  $\mathcal{A}$ , however, larger  $M$  have diminishing effect on the compression potential of the Cloud, as the Cloud can not compress  $M$  efficiently. We will discuss this in more detail in Section VI. The Client then encrypts the  $D$  using a symmetric encryption ENC with a secret key  $K$  to generate  $E$ . Unlike Dual Deduplication, where  $D$  is stored locally in the Client, the Client in Bifrost only stores  $K$  locally and sends the encrypted value  $E$  to the Cloud. As for the exact encryption algorithm, the Client is free to choose the encryption algorithm and the size of the used private key. This gives the flexibility to the Client to choose the best encryption algorithm based on the use case,

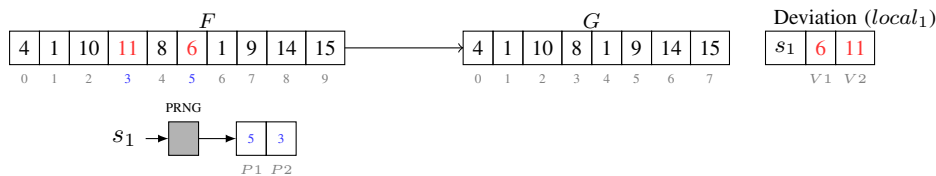

Fig. 4. An illustration of the transformation TRANSF in the Client to create  $G$  and  $D$ .

computational power and desired privacy guarantees. Finally, the user stores  $M$ , and private keys for both  $M$  and  $E$ , and sends  $M$ ,  $G$ , and  $E$  to the Cloud.

(3) The Cloud performs deduplication on the received  $G$ , as in [1]. We note that the Cloud would like to compress the received  $E$  in order to provide better storage efficiency. However, as the sizes of  $E$  is significantly small compared to  $G$ , and the ciphertext output by the symmetric encryption scheme looks random to the Cloud, reducing the fingerprint of the received  $E$  is not efficient and worthwhile.

### B. Secure File Sharing

This stage includes three parties, namely, a Client that wants to share its data, denoted by Sender; a Client that wishes to receive the data, i.e., Receiver; and the Cloud. We further assume that both Sender and Receiver use or have access to the same PRNG, so that when using the same seed, the output of the PRNG for both entities is exactly the same. (4) When a Sender wants to share its data, it sends  $M$ , the private key for HMAC, i.e.,  $K'$  and the private key for ENC, i.e.,  $K$  to the Receiver. (5) The Receiver uses  $M$ , which is acting as the file identifier to the data on the Cloud, to retrieve the respective  $G$  and  $E$  from the Cloud. (6) After the Cloud receives the download request from the Receiver, it decompresses the data, by reversing the steps it took during the compression step, and sends the  $G$  and  $E$  to the Receiver. (7) As the receiver now has the components necessary to reconstruct the original file  $F$ . It follows the following steps to reconstruct the  $F$  and checks the integrity of the data.

- 1) (8) Decrypt  $E$  using the secret key  $K$  to obtain the plaintext  $D$ .
- 2) (9) Use  $D$  and  $G$  in order to reconstruct  $F$  by inserting the values stored in  $D$  into their positions, generated by the seed stored in  $D$  and the PRNG.
- 3) (10) Calculate the HMAC of  $F$  and verify the result with  $M$  to ensure the integrity of the data.

The integrity check in the Receiver ensures that the file  $F$  is reconstructed successfully and is the same file  $F$  that was originally in the Sender.

## V. PRIVACY ANALYSIS OF Bifrost

In Bifrost we use three main cryptographic primitives on the Clients' side: a PRNG (used in TRANSF), a symmetric encryption scheme ENC, and an HMAC. Intuitively, we protect data privacy from a malicious Cloud in two steps: first we delete a portion of the original file (in TRANSF, the indexes of the values to be deleted are determined by

the output of a PRNG on a given seed), then we encrypt deviation  $C$  (which contains the seed and the deleted values) using a secure symmetric encryption scheme ENC. Notably,  $G$  is a punctured version of  $F$ , and this transformation has been shown to provide strong privacy guarantees as it mimics a deletion channel [1]. In our security analysis, we idealize PRNG to a random oracle, and demand ENC to be IND-CCA2 secure. Finally, to ensure the integrity of the outsourced data, we employ a MAC tag  $M$ , generated by HMAC on the plaintext  $F$ . Although HMAC is designed to provide data integrity only, in our security analysis we model it as a random oracle, which ensures  $M$  leaks no information about the plaintext data.

In order to argue the privacy of Bifrost we make the following set of assumptions on the knowledge and the computational power of our adversary  $\mathcal{A}$ .

**Assumption 1.** *The adversary  $\mathcal{A}$  knows the probability distribution of the plaintext data  $F$ , and has access to all resourced uploaded to the Cloud, i.e.,  $G$ ,  $E$ , and  $M$ .*

**Assumption 2.** *The adversary  $\mathcal{A}$  has no access to Clients' cryptographic key material (in particular,  $K$  and  $K'$  are unknown to  $\mathcal{A}$ ).*

**Assumption 3.** *The adversary  $\mathcal{A}$  has computational power bounded by polynomial-time algorithms, executed on a classical computer (we do not consider quantum adversaries).*

Furthermore, we make the following assumptions on the cryptographic primitives used in Bifrost:

**Assumption 4.** *The algorithms PRNG and HMAC act as random oracles; that is: their output are random strings uncorrelated to the input, except for consistency, i.e., the same input returns the same output.*

**Assumption 5.** *The ENC algorithm satisfies the security notion of indistinguishability under chosen plaintext attack (IND-CCA2).*

**Assumption 6.** *The HMAC algorithm is unforgeable.*

Assumptions 4 and 5 have the two following major implications:

First, given a string  $G$ ,  $\mathcal{A}$  cannot identify the position of the symbols deleted by TRANSF better than a random guess. In particular, modelling the PRNG as a random oracle makes TRANSF behave like a deletion channel on  $F$ . It is proven that the deletion channel is a hard problem for the receiver

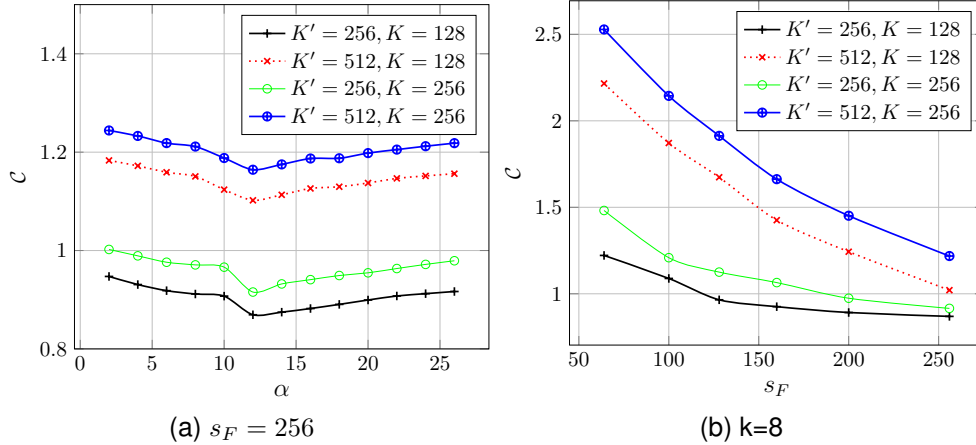

Fig. 5. The compression rate for different techniques

( $\mathcal{A}$  in this case) who cannot deterministically reconstruct the original string using the received punctured version [6].

Second, given,  $G$ ,  $E$ , and  $M$ , it is computationally infeasible for  $\mathcal{A}$  to retrieve values deleted by TRANSF and recover the original plaintext file  $F$ . This is essentially due to the fact that  $E$  and  $M$  are output of random oracles and  $G$  is the output of a deletion channel (as discussed in the previous point).

We move on to proving integrity of the downloaded data. In this case we are concerned with an adversary that acts as a malicious Cloud, modifies the outsourced data, and returns inconsistent values to download requests. To detect and deter such misbehavior, Bifrost employs a HMAC. We recall that in Bifrost, the tag  $M$  output by HMAC serves both as a file identifier and as token for integrity check. When the Client (Sender) shares its data with another Client (Receiver), it sends  $M$  on a P2P, private channel. The Receiver uses  $M$  to check the validity of the data it receives from the Cloud. By Assumptions 2 and 6,  $\mathcal{A}$  has no access to the secret key  $K'$  and HMAC is unforgeable. Therefore, it is computationally infeasible for  $\mathcal{A}$  to modify  $G$  or  $E$  without being detected.

## VI. NUMERICAL RESULTS AND DISCUSSION

In this Section, we provide numerical results gathered by simulation of Bifrost. We use a C++ based implementation consisting of a cloud and 2 clients, where one client stores data on the cloud and then shares it with the second client. We use 10GB of HDFS and 8GB of DVI data-sets. For the sake of having more diverse data, we use a random portion of both datasets in our experiments. We set the size of each original string  $F$  to 2048 bits and a symbol size of 8 bits. In other words, our data consists of strings of 256Bytes, and the deletion in the client as well as the deduplication on the cloud is performed on the Byte level. For our PRNG, we use a seed size of 32 bits.

In order to analyze the trade-off between security and the compression rate/transmission overhead in Bifrost, we experiment with multiple setups as HMAC and encryption

function (ENC). For our encryption function, we use AES with key sizes of 128 bits and 256 bits.

For our HMAC, we used two different setups, 1) HMAC based on SHA-2 with a key size of 256 bits, resulting in a hash size of 256 bits. 2) HMAC based on SHA-2 with a key size of 512 bits, resulting in a hash size of 512 bits.

Note that the larger size of keys in HMAC and encryption, i.e., the larger size of  $K'$  and  $K$ , the system would provide higher security for the data, as the encryption and the HMAC would be harder to break for the adversary. However, we note that all of the setups used in this simulation are currently considered computationally secure in real-world applications.

### A. Compression rate

In Fig. 5, we show the compression rate on the cloud for different setups of the HMAC and encryption. For this experiment, we have considered chunk size of up to 256 Bytes, which is the upper bound for current dual deduplication system as mentioned in [1]. In Fig. 5.a, we calculate the compression rate for different values of  $\alpha$  when the chunk size  $s_F = 256$  Bytes. As this Figure suggests, for lower values of  $\alpha$ , the more deletions we have in the client, i.e., higher the number of  $\alpha$  is, the more compression we achieve on the Cloud. This is due to two facts. 1. For lower number of deletions, the size of the secret piece  $D$  is lower than the size of the key used for encryption, therefore, the AES coding protocol uses padding to generate blocks of 128 bits, producing overhead in the Cloud; and 2. By having more deletions, the size of the outsource  $s_G$  is reduced, increasing the potential for deduplication in the Cloud. After a certain threshold, this trend is reversed and the Cloud loses its compression potential by increasing the value of  $\alpha$ . This behavior occurs as by having more deletions, the size of  $D$  grows, which is the part of the data that is encrypted and therefore cannot be efficiently compressed. We believe that this threshold depends on the encryption algorithm. For this particular experiment the optimal compression rate is for when  $\alpha = 12$ , i.e., when the size of  $D$  is exactly 128 bits, which is exactly the same value as the cipher blocks used in AES.

TABLE I  
THE TRANSMISSION OVERHEAD IN MULTIPLE SECURE FILE SHARING SYSTEMS.

Protocol name	Cloud to Client	Client to Client	Privacy	Compression
Bifrost	402MB	2372bits	Yes	Yes
Plutus [7]	404MB	1024bits	Yes	No
SEGShare [12]	404MB	2200bits	Yes	No
No Cloud	0	400MB	Yes	No
Only Cloud	400MB	0	No	Yes

In Fig. 5.b, we calculate the best compression rate for different values of  $s_F$ . In this plot, we have illustrated the best compression rate achievable for each value of  $s_F$ , which is when  $\alpha = 12$ . As this graph suggests, we achieve the best compression rate for the highest value of  $s_F$ , as in this case, the proportion of  $E$  and  $M$  to the total size of the the database is lower.

In our particular setup, we are able to achieve a compression rate of 86.94%, of which 17.46% is the size of  $M$  and  $E$  and 69.48% is the size of the  $G$ . This compression rate is achieved for the lowest values on the size of the keys  $K'$  and  $K$ . As an alternative approach, we can encrypt the  $D$  generated by multiple chunks in a single file using the same  $K$  and produce a single  $M$  for multiple chunks in the file. Using this approach, we reduce the required storage for the  $M$  on the Cloud, as well as the required storage on the Client for the keys  $K'$  and  $K$ . However, this approach reduces the security of Bifrost, as if an adversary is able to break a single chunk and obtain the  $K$ , it can break all the chunks that used the same key in ENC.

### B. Transmission overhead

For this paper, we have analyzed the theoretical overhead on the transmission between Cloud and Clients in Bifrost, and compared it with the extreme cases of file sharing as well as some secure file sharing systems. Table I shows the required transmission between different parties when using Bifrost, Plutus [7], SEGShare [12] and the extreme cases of only using the Cloud and only using the P2P channel. Note that these values are theoretical and are for a file size of  $s_F = 200MB$ . In this table, we assumed that the  $D$  for all chunks of the file is encrypted with a single key  $E$ , with the size of 128bits; and we produce a single  $M$  for every 100 chunks of the file using a unique key  $K'$  with a size of 256 bits. This leads to the total transmission overhead of 384 bits for the keys and 2MB for the  $M$  in the P2P channel. For the transmission in the channel between the Cloud and the Receiver, we note that the Receiver is required to download the whole  $G$ , as the Cloud decompresses the data before sending it to the Receiver. Therefore, the required transmission in that channel is equal to the size of the file and the file identifier ( $s_F + s_{fid}$ ). Comparing these schemes, we see that Bifrost achieves a competitive transmission cost in the case of file sharing between two Clients, while having a high compression rate on the Cloud, which is not provided in the other secure file sharing systems.

## VII. CONCLUSION AND FUTURE WORK

In this work, we propose Bifrost, an innovative secure file sharing system based on dual deduplication [1], which provides computational privacy for the data of the clients against a malicious cloud or client, while allowing the untrusted cloud storage to compress the data. We achieve this goal by storing a fixed amount of data for each file in the clients, regardless of the size of the file, making the proposed solution scalable to large amounts of data. Our analysis shows that the computational security is provided by storing only 650 bits for each file in the client side.

The proposed method is unique in its focus on provide compression on the data, allowing for more clients to use the cloud storage system to store and share their data in a secure way. Our experiments show that the cloud can achieve 86.9% compression rate, without reducing the security of Bifrost. Future work will focus on (a) revoking the rights of other clients to read or write the data stored on the cloud, (b) analysis of the trade-off between security and compression for different security and compression schemes, and (c) protection against malicious receiver without revealing unwanted information. As dual deduplication is a recent topic, the privacy and security opportunities of it will require further work.

## VIII. ACKNOWLEDGMENT

This work was partially financed by the SCALE-IoT project (DFE-7026-00042B) granted by the Danish Council for Independent Research, the Innovation Fund Denmark (8057-00059B), the AUFF Starting Grant AUFF2017-FLS-7-1, Aarhus University's DIGIT Centre and by the Swedish Foundation for Strategic Research (RIT17-0035), and the strategic research area ELLIIT.

## REFERENCES

- [1] Hadi Sehat, Elena Pagnin, and Daniel E Lucani. Yggdrasil: Privacy-aware dual deduplication in multi client settings. In *ICC 2021-IEEE International Conference on Communications*, pages 1–6. IEEE, 2021.
- [2] Terry A. Welch. A technique for high-performance data compression. *Computer*, 17(06):8–19, 1984.
- [3] Cornel Constantinescu, Joseph Glider, and David Chambliss. Mixing deduplication and compression on active data sets. In *2011 Data Compression Conference*, pages 393–402. IEEE, 2011.
- [4] Rasmus Vestergaard, Qi Zhang, and Daniel E Lucani. Generalized deduplication: bounds, convergence, and asymptotic properties. In *2019 IEEE Global Communications Conference (GLOBECOM)*, pages 1–6. IEEE, 2019.
- [5] Lars Nielsen, Rasmus Vestergaard, Nilofar Yazdani, Prasad Talasila, Daniel E Lucani, and Márton Sipos. Alexandria: a proof-of-concept implementation and evaluation of generalised data deduplication. In *2019 IEEE Globecom Workshops (GC Wkshps)*, pages 1–6. IEEE, 2019.

- [6] Michael Mitzenmacher. A survey of results for deletion channels and related synchronization channels. *Probab. Surveys*, 6, 2009.
- [7] Mahesh Kallahalla, Erik Riedel, Ram Swaminathan, Qian Wang, and Kevin Fu. Plutus: Scalable secure file sharing on untrusted storage. In *Fast*, volume 3, pages 29–42, 2003.
- [8] Eu-Jin Goh, Hovav Shacham, Nagendra Modadugu, and Dan Boneh. Sirius: Securing remote untrusted storage. In *NDSS*, volume 3, pages 131–145. Citeseer, 2003.
- [9] Stefan Contiu, Sébastien Vaucher, Rafael Pires, Marcelo Pasin, Pascal Felber, and Laurent Réveillère. Anonymous and confidential file sharing over untrusted clouds. In *2019 38th Symposium on Reliable Distributed Systems (SRDS)*, pages 21–2110. IEEE, 2019.
- [10] Dan Boneh, Craig Gentry, and Brent Waters. Collusion resistant broadcast encryption with short ciphertexts and private keys. In *Annual international cryptology conference*, pages 258–275. Springer, 2005.
- [11] Jingwei Li, Chuan Qin, Patrick PC Lee, and Jin Li. Rekeying for encrypted deduplication storage. In *2016 46th Annual IEEE/IFIP International Conference on Dependable Systems and Networks (DSN)*, pages 618–629. IEEE, 2016.
- [12] Benny Fuhry, Lina Hirschhoff, Samuel Koesnadi, and Florian Kerschbaum. Segshare: Secure group file sharing in the cloud using enclaves. In *2020 50th Annual IEEE/IFIP International Conference on Dependable Systems and Networks (DSN)*, pages 476–488. IEEE, 2020.
- [13] Chuan Qin, Jingwei Li, and Patrick PC Lee. The design and implementation of a rekeying-aware encrypted deduplication storage system. *ACM Transactions on Storage (TOS)*, 13(1):1–30, 2017.
- [14] Douglas L Whiting and Tom Dilatush. System for backing up files from disk volumes on multiple nodes of a computer network, July 7 1998. US Patent 5,778,395.
- [15] Daniel E Lucani, Lars Nielsen, Claudio Orlandi, Elena Pagnin, and Rasmus Vestergaard. Secure generalized deduplication via multi-key revealing encryption. In *International Conference on Security and Cryptography for Networks*, pages 298–318. Springer, 2020.
- [16] K Akhila, Amal Ganesh, and C Sunitha. A study on deduplication techniques over encrypted data. *Procedia Computer Science*, 87:38–43, 2016.
- [17] Wen Xia, Hong Jiang, Dan Feng, Fred Douglass, Philip Shilane, Yu Hua, Min Fu, Yucheng Zhang, and Yukun Zhou. A comprehensive study of the past, present, and future of data deduplication. *Proceedings of the IEEE*, 104(9):1681–1710, 2016.