

---

# AESPA: Accuracy Preserving Low-degree Polynomial Activation for Fast Private Inference

---

Jaiyoung Park<sup>1</sup> Michael Jaemin Kim<sup>1</sup> Wonkyung Jung<sup>1</sup> Jung Ho Ahn<sup>1</sup>

## Abstract

Hybrid private inference (PI) protocol, which synergistically utilizes both multi-party computation (MPC) and homomorphic encryption, is one of the most prominent techniques for PI. However, even the state-of-the-art PI protocols are bottlenecked by the non-linear layers, especially the activation functions. Although a standard non-linear activation function can generate higher model accuracy, it must be processed via a costly garbled-circuit MPC primitive. A polynomial activation can be processed via Beaver’s multiplication triples MPC primitive but has been incurring severe accuracy drops so far.

In this paper, we propose an accuracy preserving low-degree polynomial activation function (AESPA) that exploits the Hermite expansion of the ReLU and basis-wise normalization. We apply AESPA to popular ML models, such as VGGNet, ResNet, and pre-activation ResNet, to show an inference accuracy comparable to those of the standard models with ReLU activation, achieving superior accuracy over prior low-degree polynomial studies. When applied to the all-RELU baseline on the state-of-the-art Delphi PI protocol, AESPA shows up to  $42.1\times$  and  $28.3\times$  lower online latency and communication cost.

## 1. Introduction

*Private inference (PI) protocols* (Liu et al., 2017; Mishra et al., 2020; Juvekar et al., 2018), or hybrid PI protocols exploiting multi-party-computation (MPC (Yao, 1982)) and homomorphic encryption (HE (Gentry, 2009)), are one of the most prominent approaches in machine-learning-as-a-service (MLaaS) to support sensitive data, such as medical history (Agrawal et al., 2019; Riazi et al., 2019). In these protocols, MPC primitives and HE are combined in a

complementary manner (e.g., HE is used for linear layers and MPC primitives used for non-linear layers). Although promising, the performance (i.e., serving latency) of the PI protocols is commonly bottlenecked by the non-linear layers of the machine learning (ML) models, especially activation functions (Juvekar et al., 2018; Mishra et al., 2020). While standard activation functions such as ReLU can generate higher model accuracy, they rely on slow and communication/storage-hungry primitives such as garbled-circuit (GC) MPC primitive (Yao, 1986) due to the required bitwise operations. In contrast, the polynomial activation functions have an advantage in that they can be processed via less costly Beaver’s multiplication triples (BT) MPC primitive (Beaver, 1995), but are limited by the lower model accuracy.

Prior works have tackled this challenge in various ways. First, one set of prior art tried to minimize the model accuracy drop with a polynomial activation function that replaces ReLU. CryptoNet (Gilad-Bachrach et al., 2016) was the first to demonstrate a working ML model with a polynomial activation function in the context of PI. Subsequent studies (Garimella et al., 2021; Ishiyama et al., 2020; Obla et al., 2020; Hesamifard et al., 2019; Thaine et al., 2019; Lou & Jiang, 2021; Lee et al., 2021) explored various polynomial functions based on numerical analysis such as Taylor polynomials or minimax approximation (Veidinger, 1960).

However, the ML models with polynomial activation often suffer from limited trainability when the model is deep for a large task, low model accuracy, or high serving latency when pursuing a high accuracy. (Gilad-Bachrach et al., 2016) was limited to a shallow model for a simple task of MNIST. (Lee et al., 2021) minimized the accuracy drop for deeper models with larger tasks of CIFAR-10 and ImageNet by exploiting the minimax approximation function. However, it was limited from the long latency caused by high polynomial degree (e.g., 29) for approximation; a higher degree means that more MPC primitives must be used.

Second, another set of studies (Mishra et al., 2020; Lou et al., 2021) utilized the neural architecture search (NAS) method (Zoph & Le, 2017) to find optimal activation layer locations (in terms of model accuracy and online inference latency) to substitute with the polynomial activation while

<sup>1</sup>Dept. of Intelligence and Information, Seoul National University. Correspondence to: Jung Ho Ahn <gajh@snu.ac.kr>.

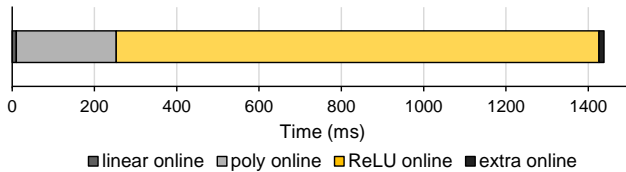

Figure 1. The online latency breakdown of Delphi (Mishra et al., 2020) for ResNet32, where 26 ReLU functions are approximated with quadratic polynomials and processed via Beaver’s Triple, whereas 5 ReLUs are processed as via Garbled Circuit. Experimental details in Section 4.1.

leaving others with the original ReLU. However, despite the use of NAS, the acquired models still exhibit large room for improvement in both accuracy and latency because not all activation layers can be replaced with polynomials, and the remaining few activation layers take up the majority of the total online latency. Delphi (Mishra et al., 2020), a state-of-the-art PI protocol utilizing NAS, greatly reduced the online latency, achieving 3.8 seconds and 65.7% accuracy for ResNet32 on CIFAR-100, when 26 out of 31 ReLUs are replaced into a quadratic approximation, for instance. However, up to 82% of the online latency is spent on GC for the five remaining ReLUs (see Figure 1); no more ReLUs can be replaced due to the sharp drop in the model accuracy.

In this paper, we propose an Accuracy prEServing low-degree Polynomial Activation (AESPA) that can replace all ReLUs in the neural networks, using the *Hermite polynomial* concatenated with the *basis-wise normalization*. While prior studies (Lokhande et al., 2020; Ge et al.; Agarwal et al., 2021; Panigrahi et al., 2020) inspired our work, they were mainly in the theoretical domain. None had explored nor demonstrated the practicality of the Hermite polynomials in the PI context or was able to reach high accuracy as our Delphi method. Our composition of Hermite expansion and basis-wise normalization substantially mitigated vanishing (or exploding) gradient problems, which are frequently encountered with the polynomial activation functions, allowing us to achieve high model accuracy even using the low-degree polynomials.

We first present the organization of our Hermite polynomial with the basis-wise normalization (HerPN) block and show how it can be used to modify ResNet (He et al., 2016a), pre-activation ResNet (PA-ResNet (He et al., 2016b)), and VGG (Simonyan & Zisserman, 2015) (Section 3). Then, we report the smaller (better) accuracy drop of the trained models using the HerPN blocks for CIFAR-10 and CIFAR-100 datasets over the prior polynomial activation ML models of (Lee et al., 2021; Garimella et al., 2021). Moreover, we demonstrate the effectiveness of the HerPN-modified ML models for a state-of-the-art PI protocol, Delphi, on the real machine and network (Section 4). By replacing all ReLUs with our HerPN blocks and processing them with BT, the online latency and communication for evaluating the ML

models such as ResNet18/32, PA-ResNet18/32, and VGG16 are reduced by up to  $42.1\times$  and  $28.3\times$ , respectively. The accuracies of the ML models with the HerPN block are also competitive with the original models with ReLU for CIFAR-10/100.

The key contributions of this paper are as follows:

- We propose a novel low-degree polynomial activation function that utilizes the Hermite polynomial concatenated with the basis-wise normalization, which sustains the high accuracy of the ML model.
- We demonstrate superior accuracy over prior polynomial activation works on large datasets such as CIFAR-10/100.
- We showcase the effectiveness of our work in the PI context, in terms of latency and communication costs, on a real machine and network using the open-source Delphi PI protocol.

## 2. Background

### 2.1. Private inference (PI) and hybrid PI protocols

Private inference (PI) refers to a set of techniques that enable machine learning (ML) inference without the need to reveal i) the private data of a client to a service provider or ii) the trained model of a service provider to a client. Fully-homomorphic-encryption (FHE) (Chillotti et al., 2020; Gentry, 2009; Cheon et al., 2017; Fan & Vercauteren, 2012), federated learning (Bonawitz et al., 2019; Konečný et al., 2016), or works based on enclaves (Costan & Devadas, 2016; Ngabonziza et al., 2016) all pursue practical PI. However, none has proven to be dominantly superior to the others regarding the security level, latency, or accuracy of the supporting ML models. In particular, while FHE might be a promising option for the PI, it is limited by i) the extremely costly bootstrapping operation to enable an unlimited depth of operations for deep ML models and ii) the limited applicability to only linear layers and polynomial functions.

Hybrid *PI protocols* based on both MPC primitives and HE attempt to provide a prominent option for private inference (Juvekar et al., 2018; Mishra et al., 2020; Liu et al., 2017). These PI protocols often exploit the leveled-HE (LHE, which does not support bootstrapping) for ML *linear layers*. As LHE evaluates a single linear layer at a time, no bootstrapping operation is necessary, thus incurring a shorter computation time than FHE. A PI protocol often processes the non-linear activation function via MPC primitives. MPC primitives require minimal computation time at the cost of high communication costs between the client and the server. Our work focuses on the latter of processing activation functions with the MPC primitives.

## 2.2. Cryptographic primitives

The hybrid PI protocols rely on multiple cryptographic primitives, either the ones from MPC or HE, to effectively support the private inference. Parameters about the finite field and data representation in cryptographic primitives are explained in Appendix B.

**Additive secret sharing (SS (Shamir, 1979)):** SS is a cryptographic primitive that divides a secret value  $\langle x \rangle$  into multiple shares  $\langle x \rangle_1, \langle x \rangle_2, \dots, \langle x \rangle_n$  distributed to  $n$  parties so that a single party does not have complete knowledge of the original secret. In a two-party SS, the secret shares of the value  $x$  can be generated by randomly sampling a value  $r$  and distributing the shares  $\langle x \rangle_1 = r$  and  $\langle x \rangle_2 = x - r$  to each party. The reconstruction of the original secret is straightforward, by pooling shared values from the two parties and adding up:  $\langle x \rangle = \langle x \rangle_1 + \langle x \rangle_2$ .

**Beaver’s multiplication triples (BT (Beaver, 1995)):** BT is a two-party protocol that can securely compute the product of the two secret-shared values. The whole protocol is divided into two steps: generation and multiplication procedures. For the first step to prepare for the multiplication, Beaver’s triples are generated; randomly sampled  $a$ ,  $b$ , and  $a \cdot b$  are secret-shared between two parties  $P_1$  and  $P_2$ . As a second step, when the actual input  $x$  and  $y$  are already secret-shared (namely  $P_1$  holds  $\langle x \rangle_1, \langle y \rangle_1$  and  $P_2$  holds  $\langle x \rangle_2, \langle y \rangle_2$ ), through Beaver’s multiplication procedure the SS of their product is generated and shared (namely  $\langle xy \rangle_1$  for  $P_1$  and  $\langle xy \rangle_2$  for  $P_2$ ). During this second step, one set of Beaver’s triples is consumed for every multiplication.

**Garbled circuit (GC (Yao, 1986)):** GC is a two-party protocol that enables garbler and evaluator to securely compute an arbitrary boolean circuit ( $C$ ) without revealing their private inputs. Initially, a garbler holds its private data  $x_g$  and boolean circuit  $C$ , while an evaluator holds its private data  $x_e$ . The protocol starts with the garbler encoding (garbling) the circuit to generate garbled circuit  $\hat{C}$ , which takes encoded inputs (labels) and can evaluate the original circuit  $C$ . The garbler sends  $\hat{C}$  and encoded data  $L(x_g)$  to the evaluator. The label for the evaluator’s input,  $L(x_e)$ , can be computed by using the Oblivious Transfer protocol<sup>1</sup> (Rabin, 2005) with the garbler. Finally, the evaluator computes  $Eval(\hat{C}, L(x_g), L(x_e))$ , which outputs  $y = C(x_g, x_e)$ .

**Homomorphic encryption (HE (Chillotti et al., 2020; Gentry, 2009; Cheon et al., 2017; Fan & Vercauteren, 2012)):** HE is a set of public-key encryption schemes that allow arithmetic operations on the ciphertext without the need for decryption. Assuming messages  $m_1$  and  $m_2$ , a public-key  $pk$ , a secret key  $sk$ , an HE encryption scheme  $\mathbb{E}$ ,

<sup>1</sup>Oblivious Transfer (OT) is also a type of MPC primitives. OT allows the sender to transfer only one of multiple possible data without knowing what has been transferred.

Table 1. Latency and communication costs of BT processing polynomial activation and GC processing ReLU. Each is measured in the Delphi protocol for ResNet32, amortized to a single operation.

Activation function	Time ( $\mu$ s)		Comm. (KB)	
	Offline	Online	Offline	Online
Polynomial activation	2.80	1.20	0.192	0.036
ReLU	60.60	20.22	19.088	1.184

and an HE decryption scheme  $\mathbb{D}$ , a homomorphic evaluation  $Eval$  satisfies the following upon some function of  $f$ :  $\mathbb{D}(sk, Eval(pk, \mathbb{E}(pk, m_1), \mathbb{E}(pk, m_2), f)) = f(m_1, m_2)$ . Due to the HE nature that errors accumulate over computations, only a limited number of HE operations ( $Eval$ ) can be executed upon an encrypted message. A bootstrapping operation can reset the accumulated errors, but only at the cost of high computational complexity. A leveled-HE refers to a set of HE schemes that do not support bootstrapping operation incurring lower cost but providing limited depth, while fully-HE refers to those that do support the bootstrapping.

GC supports arbitrary functions such as ReLU, but only at the cost of high communication/storage for the garbled circuits and exchanged labels. BT supports multiplications with relatively lower-cost than GC but can only support polynomial activation functions, which leads to lower model accuracy. Table 1 summarizes the latency and communication costs of BT and GC, while each processing polynomial activation and ReLU, respectively. HE is different in that it does not require multiple communication rounds or additional storage costs; however, it is limited in the depth of the computation and the supportable operations such as compare, which is necessary for ReLU.

## 2.3. Delphi overview

Delphi (Mishra et al., 2020) is a representative hybrid PI protocol based on the MPC primitives and HE. Delphi exploits LHE for the linear layers of an ML model and either GC or BT for the activation functions of the model. The inference under the Delphi protocol consists of offline and online phases (see Figure 5 in Appendix A). The offline phase is independent of the client’s actual input data and thus can be pre-processed. The online phase begins when the client sends their private data to the server and ends when the client learns the final inference results.

We first illustrate the cryptographic primitives used for the linear and activation layers, clarifying the offline and online phases. The subscript  $i$  denotes an  $i^{th}$  layer of the neural network. At each layer of the online phase, the server and client hold the SS of the layer inputs at the beginning and the SS of the layer output at the end.

**Linear layer:** During the offline phase, random masking matrices ( $r_i$  at the client and  $s_i$  at the server) are generated.

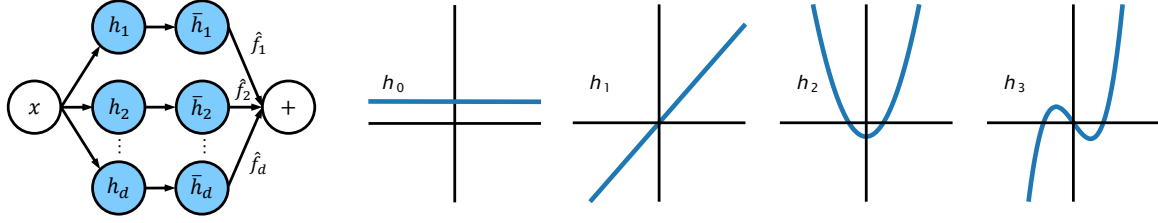

Figure 2. HerPN block. For one input feature, several Hermite basis polynomials of input are evaluated. The computed Hermite polynomials experience separate basis-wise normalization and weighted summation using Hermite coefficients (left). The first four Hermite basis polynomials are depicted in the right.

The shapes of  $r_i, s_i$  are identical to the input matrix of the  $i^{\text{th}}$  layer. The client first sends a ciphertext  $\mathbb{E}(r_i)$  to the server. The server evaluates  $\mathbb{E}(W_i r_i - s_i)$  using HE operations and returns this ciphertext to the client. The client decrypts the ciphertext and obtains  $W_i r_i - s_i$ . When the online phase starts, the server holds  $x_i - r_i$  either from the output of the last layer or the client. The server then computes the plaintext operation of  $W_i(x_i - r_i) + s_i$ . As a result, the client and the server hold the SS of  $W_i x_i$ .

**Activation layer:** Cryptographic primitives used for the activation layer depend on the type of the activation function; GC for ReLU or BT for polynomial activation, quadratic approximation in particular. Regardless of the type, the server begins its online phase with  $W_i(x_i - r_i) + s_i$ .

i) *ReLU and GC:* The server acts as a garbler with its private input of  $W_i(x_i - r_i) + s_i$  and the circuit  $C$  of ReLU, while the client acts as an evaluator with its private input of  $W_i r_i - s_i$  and  $r_{i+1}$ . During the offline phase, the garbled circuit  $\hat{C}$  and the labels  $L(r_{i+1})$  and  $L(W_i r_i - s_i)$  are sent from the server to the client. When the online phase starts, the label  $L(W_i(x_i - r_i) + s_i)$  is sent from the server to the client, where the client evaluates  $\hat{C}$  to generate  $x_{i+1} - r_{i+1}$ , sending it back to the server. Then, the online phase of the next linear layer can begin.

ii) *Quadratic approximation and BT:* In the offline phase, the client and the server simply secret-share Beaver’s triples. When the online phase begins, the server and client compute and gain the secret share of  $x_{i+1}$  consuming a set of triples;  $\langle x_{i+1} \rangle_1$  at the client and  $\langle x_{i+1} \rangle_2$  at the server. As a final stage, the client sends  $\langle x_{i+1} \rangle_1 - r_{i+1}$  to the server, allowing the server to gain  $x_{i+1} - r_{i+1}$  for the next linear layer in the online phase.

Delphi employs NAS (Zoph & Le, 2017) to search for an optimal ML model that replaces some of its GC-processed ReLUs with BT-processed quadratic approximations, considering the tradeoff between the model accuracy and costs, including the online serving latency. The online latency is dominated by the activation layers. While the linear layer only requires fast plaintext computation, the activation layer demands high communication costs between the client and the server, which are especially higher in the case of GC

compared to BT. However, one cannot naïvely replace ReLUs (processed via GC) with polynomial activations (processed via BT) to reduce the online latency because the accuracy of an ML model easily deteriorates when the ReLU functions are replaced by simple quadratic approximation functions. Delphi attempts to find a sweet spot amongst this tradeoff exploiting NAS.

Although promising, the obtained ML models are either not fast enough (taking 11.3 secs for inferring ResNet18 on CIFAR-10 in our setup) compared to 0.1354 msec (Coleman et al., 2017) in a non-PI context. Multiple works including (Lou et al., 2021; Cho et al., 2021; Ghodsi et al., 2020; Jha et al., 2021) further optimized the training method, NAS structure, or even the polynomial activation function options, but these works have still achieved limited success in the latency or accuracy.

## 2.4. Polynomial activation functions

Various prior arts have attempted to provide effective polynomial activation functions (Garimella et al., 2021; Ishiyama et al., 2020; Obla et al., 2020; Hesamifard et al., 2019; Thaine et al., 2019; Lou & Jiang, 2021; Lee et al., 2021; Gilad-Bachrach et al., 2016). However, they either suffer from the inferior *accuracy* of the model or the high online service *latency* in the PI context. Especially when using low degree polynomials (2 or 3), they can only train shallow neural networks consisting of fewer than ten layers. (Garimella et al., 2021) proposed a QuaIL method that trains a polynomial activation-based model by optimizing the mean squared error (MSE) of an intermediate result from a pretrained ReLU-based model and report training deep networks using degree 2 polynomials. However, the reported accuracy is noticeably inferior to that of neural networks using ReLU. Contrarily, (Lee et al., 2021) proposed a high degree (e.g., 29) minimax polynomial approximation of ReLU and max-pooling with minimal accuracy drop for ImageNet. However, high degree polynomials are costly to evaluate (Lee et al., 2021) on the PI framework with higher communication and computational costs.

### 3. Hermite polynomial with basis-wise normalization

In this section, we propose the first accuracy preserving low-degree polynomial activation function based on the Hermite polynomial concatenated with basis-wise normalization. Our method shows comparable ML model accuracy to that of the models with standard activation functions such as ReLU, while enabling minimal costs in the PI context.

#### 3.1. Orthogonal basis and Hermite polynomials

Our work utilizes Hermite expansion, a Fourier transform using Hermite polynomials as eigen-functions. Before we go deep into the construction of our activation function, we briefly describe the basic properties of orthogonal bases and Hermite polynomials. For a real interval  $[a, b]$ , let  $L^2([a, b], w(x))$  be the space of square-integrable functions with respect to a weight function  $w(x)$ . Square-integrable function is  $f : \mathbb{R} \rightarrow \mathbb{C}$  such that

$$\int_a^b |f(x)|^2 w(x) dx < \infty \quad (1)$$

Then  $L^2([a, b], w(x))$  is a Hilbert space where the inner product is defined. The inner product of two functions  $f, g \in L^2([a, b], w(x))$  is defined as follows:

$$\langle f, g \rangle = \int_a^b f(x) \overline{g(x)} w(x) dx \quad (2)$$

A finite set of polynomials  $\{p_1(x), p_2(x), \dots, p_n(x)\}$  forms an orthogonal basis if the set spans  $L^2([a, b], w(x))$  and  $\langle p_i, p_j \rangle = 0$  if  $i \neq j$ .

Hermite polynomials are a type of orthogonal polynomials that arise in probability and physics. While there are other sets of polynomials that form an orthogonal basis such as Chebyshev or Laguerre, Hermite polynomials especially feature i) Gaussian weight functions defined in  $\mathbb{R}$  and ii) orderedness, as the low order parts of the Hermite expansion hold most of the information. Mathematically, probabilist's Hermite polynomials are given by:

$$H_n(x) = (-1)^n e^{\frac{x^2}{2}} \frac{d^n}{dx^n} e^{-\frac{x^2}{2}} \quad (3)$$

to represent functions (e.g., ReLU)

Then, the normalized Hermite polynomials  $h_n(x) = \frac{1}{\sqrt{n!}} H_n(x)$  form an orthonormal basis in the  $L^2(\mathbb{R}, e^{-x^2/2})$  in the sense that the series of the polynomial  $\{h_i\}_{i=0}^{\infty}$  are orthonormal:  $\langle h_i, h_j \rangle = \delta_{i,j}$ . Here  $\delta_{i,j} = 1$  if  $i = j$  and otherwise  $\delta_{i,j} = 0$

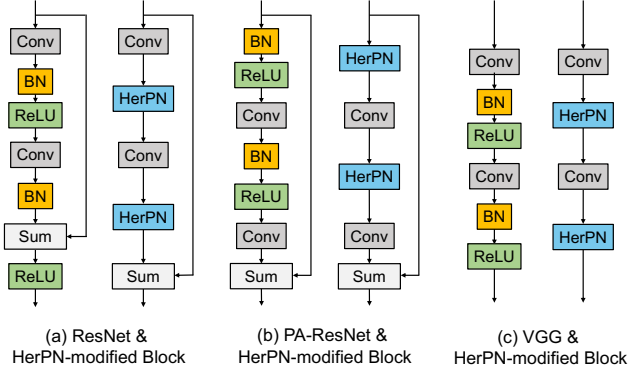

Figure 3. ResNet, PA-ResNet, and VGG ML architectures that are modified by HerPN block.

Finally, given a function  $f \in L^2(\mathbb{R}, e^{-x^2/2})$ , we have the Hermite expansion defined as the following:

$$f(x) = \sum_{i=0}^{\infty} \hat{f}_i h_i(x), \quad \hat{f}_i = \langle f, h_i \rangle \quad (4)$$

$\hat{f}_i$  is the  $i$ -th Hermite coefficient of  $f$ , defined as the inner product of the function  $f$  and the Hermite polynomial  $h_i$ .

While some prior works exploited Hermite polynomials in the neural networks, none had sought the use in the context of PI. (Panigrahi et al., 2020) used Hermite expansion of activation functions to compute a lower bound on the minimum eigenvalue of the Gram-matrix, which indicates the rate of convergence in training. (Agarwal et al., 2021) used Hermite expansion to compute the characteristic of the activation function and explain the data conditioning of the activation function. (Ge et al.) explored the population risk of the loss to avoid spurious local minima using the Hermite expansion of ReLUs. (Lokhande et al., 2020) demonstrated that the Hermite expansion of ReLU with a soft-sign function shows fast training loss convergence for a pseudo label task.

#### 3.2. The HerPN method

We propose the Hermite expansion of ReLU with basis-wise normalization (*HerPN*) block (see Figure 2) as a substitute for the ReLU and the normalization functions in neural networks. The  $n$ -th Hermite coefficient of the ReLU,  $\hat{f}_n$  is:

$$\hat{f}_n = \begin{cases} \frac{1}{\sqrt{2\pi}} & n = 0, \\ \frac{1}{2} & n = 1, \\ 0 & n \geq 2 \text{ and odd,} \\ \frac{((n-3)!!)^2}{\sqrt{2\pi n!}} & n \geq 2 \text{ and even} \end{cases}$$

Based on Formula 4, we use three bases with the highest degree of 2 ( $h_0, h_1$ , and  $h_2$  in Figure 2) for the HerPN block.

Table 2. AESPA online latency and total communication cost comparison with the baseline neural networks in Delphi. As the networks are equally structured while processing CIFAR-10 and CIFAR-100 except last fully connected layer, we only state the architecture of the neural networks.

Network	Online Latency (ms)			Communication (MB)		
	Delphi	AESPA	Improv	Delphi	AESPA	Improv
VGG16	6140.1	209.3	29.3×	329.0	11.6	28.3×
ResNet18	12281.8	291.6	42.1×	664.5	25.0	21.9×
ResNet32	6604.7	386.0	17.1×	361.6	13.6	19.5×
PA-ResNet18	12205.3	405.1	30.1×	664.5	24.7	21.7×
PA-ResNet32	7443.9	373.1	23.4×	415.4	15.7	19.8×

Using 4 bases shows similar or slightly lower accuracy compared to the case of using three.

We also employ basis-wise normalization concatenated to each basis, instead of a standard single pre/post-activation normalization. Basis-wise normalization computes the mean and variance of each Hermite polynomial over the mini-batch of training data. Instead of using trainable scale and shift parameters, we use Hermite coefficients as fixed weight. To sum up, HerPN can be computed on input  $x$  as follows:

$$f(x) = \sum_{i=0}^d \hat{f}_i \frac{h_i(x) - \mu}{\sqrt{\sigma^2 + \epsilon}} \quad (5)$$

Basis-wise normalization is critical in attaining the desired accuracy of the model for the following reasons. First, without a proper normalization technique, the output of the polynomial activation during the forward or backward propagation can exponentially increase. Thus, the ranges of a mini-batch in each layer can change drastically. Such a characteristic exacerbates with the high-degree polynomials or deep neural networks, potentially leading to the exploding or vanishing gradient problem (Garimella et al., 2021; Gilad-Bachrach et al., 2016).

Second, without the basis-wise normalization, the post-activation value may be dominated by a single highest or lowest order Hermite basis due to the differences in values from the polynomial degrees. The standard post- or pre-activation normalization does not sufficiently alleviate these problems as they overlook the scale difference between the basis expressions. Basis-wise normalization is advantageous as it keeps each basis zero-centered and consistently keeps the range of the intermediate values throughout the layers.

Using the HerPN block, we can directly replace the batch-normalization (BN) and ReLU blocks in the popular ML architectures such as pre-activation ResNet (PA-ResNet (He et al., 2016b)) and VGGNet (Simonyan & Zisserman, 2015) (Figure 3(b), (c)). We cannot directly apply HerPN to ResNet (He et al., 2016a) because a ReLU function exists after the skip-connection. We thus modify the ResNet model as shown in Figure 3(a). Although we only demon-

strate the HerPN block based on the Hermite expansion of the ReLU function, our method can also be applied to other activation functions, such as ELU (Clevert et al., 2016), SELU (Klambauer et al., 2017), Swish (Ramachandran et al., 2018), GeLU (Hendrycks & Gimpel, 2016), and Mish (Misra, 2019).

## 4. Evaluation

### 4.1. Experimental setup

**Benchmarks and datasets:** We test the private inference of our trained neural networks on CIFAR-10 and CIFAR-100 datasets. Both datasets consist of 60,000 32×32 RGB images. The training set has 50,000 images, and the test set has 10,000 images. The only difference between the two datasets is the number of classes (10 for CIFAR-10 and 100 for CIFAR-100). CIFAR-100 is the most complex dataset Delphi supports.

We perform experiments on VGG16, ResNet18/32, and PA-ResNet18/32. We first compare the performance of our HerPN-based ML models with the baseline Delphi (Section 4.2). We also compare our HerPN-based models with the prior polynomial activation works of Lee et al. (Lee et al., 2021) and QuaIL (Garimella et al., 2021) using CIFAR-10 (Section 4.3).

**System setup:** We use the AWS system to evaluate the effectiveness of our HerPN method on Delphi, obtaining the latency and communication/storage usage measurements. The hardware configurations of the client and the server are both AWS c5.2xlarge instances, which consist of Intel Xeon 8000 series CPU at 3.0 GHz with 32 GB of RAM. The client and server instances are both located in the ap-northeast-2 regions. The communication link between the client and server is in the LAN setting. We use the open-source Delphi version using the SEAL library (SEAL) for HE and the fancy garbling (fan, 2019) for GC. We report the average latency and communication cost results of 10 different experiments, which shows less than 5% fluctuation in their results.

Table 3. Accuracy result of AESPA on CIFAR-10 (C10) and CIFAR-100 (C100), compared to the standard ML models with ReLU and batch-normalization.

Dataset	Neural Network	ReLU Acc	AESPA Acc
C10	VGG16	92.78%	91.75%
	ResNet18	93.21%	94.32%
	ResNet32	91.72%	93.83%
	PA-ResNet18	95.11%	94.57%
	PA-ResNet32	92.96%	91.19%
C100	VGG16	71.44%	70.97%
	ResNet18	74.39%	61.43%
	ResNet32	67.83%	63.59%
	PA-ResNet18	72.92%	76.31%
	PA-ResNet32	68.58%	67.85%

Table 4. ML model accuracy and degree comparison of AESPA with prior polynomial activation works on CIFAR-10.

Method	Neural Network	Accuracy	Degree
AESPA	VGG16	91.75%	2
	ResNet18	94.32%	2
	ResNet32	93.83%	2
(Lee et al., 2021)	VGG16	91.87%	29
	ResNet32	89.23%	29
QuaIL	VGG16	82.25%	2
	ResNet18	83.61%	2
	ResNet32	71.81%	2

#### 4.2. Effectiveness of the HerPN-based models on the Delphi protocol

ML models with HerPN blocks demonstrate superior online latency and communication costs for all the evaluated ML models, which are reduced by up to  $42.1\times$  and  $28.3\times$  compared to the baseline Delphi (see Table 2). This reduction of costs is primarily attributed to the fact that HerPN block can replace all ReLUs in the original Delphi, allowing the full usage of the BT instead using the costly GC primitive.

#### 4.3. Comparison with the prior activation functions

ML models with HerPN blocks show accuracies comparable to those of the baseline neural networks with ReLU. Table 3 reports the accuracy of the trained baseline and HerPN-based models. In the case of VGG16 and PA-ResNet18/32, our work shows comparable or superior accuracy. HerPN-based ResNet18/32 shows a large accuracy drop on CIFAR-100 because HerPN cannot natively support the original ResNet with the skip connection. However, such drawbacks can be nullified considering that the accuracy of the HerPN-based PA-ResNet is higher than that of the original ResNet.

Table 4 compares the modified VGGNet and ResNet implemented by the prior polynomial activation works and HerPN on CIFAR-10. HerPN-based models’ accuracies are consistently higher than QuaIL, which uses the same degree

of quadratic polynomials. Compared to (Lee et al., 2021), as the degree of polynomials is far smaller, our work has significantly less computational cost on activation functions. Yet, AESPA shows accuracy higher than that of (Lee et al., 2021) on ResNet32.

#### 4.4. Effectiveness of basis-wise normalization

Through an ablation study regarding the normalization technique for HerPN block, we identified that our basis-wise normalization shows a clear advantage in terms of model accuracy over other options. Besides the baseline ResNet32 with ReLU activation and the HerPN-based ResNet32, we trained two additional ResNet32 models that exploit the Hermite expansion of the ReLU as the activation function, but adopt a standard i) *pre-activation* normalization and ii) *post-activation* normalization, instead of our basis-wise normalization. Figure 4 illustrates the loss value, train accuracy, and test accuracy of the four trained models. In the case of the pre-activation normalization, the loss does not converge to zero and fluctuates during the training. While the post-activation normalization does achieve high train accuracy, the HerPN-based case shows much higher *test* accuracy with a minimum accuracy drop compared to the baseline case with ReLU.

### 5. Related work

#### 5.1. Reducing the serving cost of activation functions for PI protocols

Gazelle (Juvekar et al., 2018) solely relies on GC and additive masking in calculating the non-linear functions. Delphi reduces the number of ReLUs relying on GC via NAS. Given the pre-trained neural network, Delphi replaces some ReLUs with quadratic approximation and retrains the neural network, which allows them to utilize a less costly BT primitive. The actual replacement process exploits a planner conducting population-based training (PBT (Jaderberg et al., 2017)) that maximizes the number of ReLU functions to be replaced with quadratic approximation and minimizes the accuracy drop. SAFENet (Lou et al., 2021) extends the replacement policy of Delphi. SAFENet introduces a more fine-grained channel-wise replacement that picks activation between zero pruning and polynomials of degree 2 or 3 for each channel.

The key weakness of these replacement-based approaches is that even with the NAS-based planner, polynomial approximation results in a severe accuracy drop after a certain approximation ratio. CIFAR-100 accuracy of ResNet32 using Delphi’s planner provides less than a 2% accuracy drop within 26 ReLU function approximations out of 31 ReLU functions. However, the accuracy of a network applying approximation to 27 or more ReLU functions drops quickly

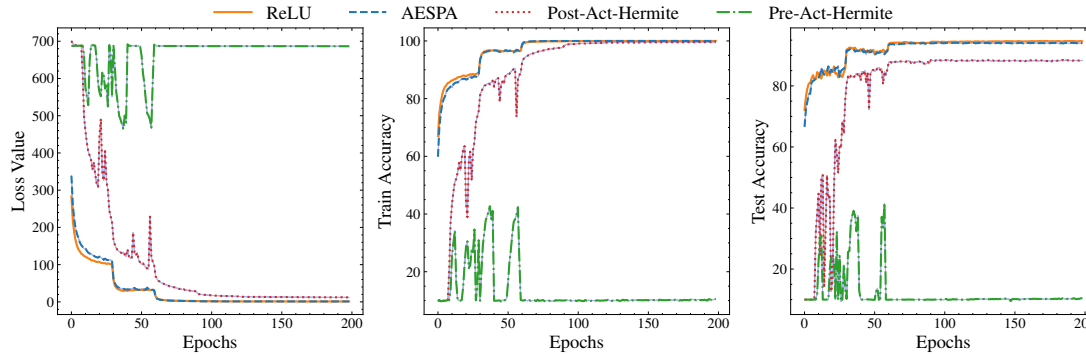

Figure 4. Comparing ML models on CIFAR-10 using different normalization techniques: i) baseline original ResNet32 with ReLU, ii) HerPN-based model, and ResNet32 with Hermite polynomial activation but with iii) post-act normalization, and iv) pre-act normalization.

compared to the network without approximation. Considering that even a small number of ReLU activation layers with GC incur the majority of the overall cost, the fact that not all activation layers can be approximated is a critical bottleneck.

Another approach is to design neural architectures from scratch optimized for the ReLU counts. (Jha et al., 2021) searches for neural architectures that can efficiently minimize the number of invoking ReLUs, rather than total FLOPs in typical NAS (Zoph & Le, 2017). However, despite using these optimizations, the remaining ReLUs account for most of the online latency.

### 5.2. Polynomial activation function works

Since CryptoNet (Gilad-Bachrach et al., 2016), there have been challenges to search for polynomial activations for PI. (Ishiyama et al., 2020; Obla et al., 2020; Hesamifard et al., 2019; Thaine et al., 2019; Lou & Jiang, 2021; Lee et al., 2021) exploit classical numerical approximations to implement polynomials that can act as the original activation function. The resulting polynomial activations are based on Taylor, Chebyshev, or MinMax approximations. These works have demonstrated superior accuracy to the square function. However, only two of them demonstrated the effectiveness of their work on deep neural networks.

First, (Lee et al., 2021) approximates a ReLU function with a high degree polynomial that successfully preserves the original model accuracy and proved its trainability on deep neural networks such as ResNet50 (He et al., 2016b) and ImageNet (Russakovsky et al., 2015). However, the high degree of the polynomial leads to longer latency on the hybrid PI protocol framework even with the BT because it necessitates a greater number of MPC primitive usages.

(Garimella et al., 2021) uses quadratic polynomial approximations and introduces QuaIL. QuaIL is an alternative training method that minimizes the MSE loss between the inter-

mediate representations of a pre-trained ReLU-based neural network and a target quadratic approximation-based neural network. With QuaIL, one can avoid exploding-gradient problems as they train a single layer at a moment while the others are frozen. However, QuaIL failed to achieve competitive accuracy because even small differences in the intermediate representation can cause divergence in subsequent layers.

Each study showed the potential of polynomials as activation functions. However, there has been no prior work demonstrating accuracy competitive to the baseline ReLU using low-degree polynomials.

### 6. Conclusion

In this paper, we have proposed an accuracy preserving low-degree polynomial activation function, AESPA. AESPA leverages the Hermite polynomial concatenated with basis-wise normalization, which retains the high accuracy of the standard ML model using ReLU. Our proposal is especially effective in the PI context because i) the polynomial activation enables less expensive BT primitive instead of GC, ii) the low degree of our work reduces the number of MPC primitives required for serving, and iii) AESPA demonstrates a high ML model accuracy even without the need of complex NAS or training methods. We also showcase the effectiveness of our work with the open-source PI protocol, Delphi, on a real machine and network for VGGNet, ResNet, and pre-activation ResNet; the online latency and the communication between the client and the server are reduced by up to  $42.1\times$  and  $28.3\times$ , respectively.

### References

Swanky. <https://github.com/GaloisInc/swanky>, 2019. Galois, Inc, Portland, OR.

Delphi. <https://github.com/mc2-project/>



- delphi, August 2021. RISELab, UC Berkeley, Berkeley, CA.
- Agarwal, N., Awasthi, P., and Kale, S. A deep conditioning treatment of neural networks. In *Algorithmic Learning Theory, 16-19 March 2021, Virtual Conference, Worldwide*, volume 132 of *Proceedings of Machine Learning Research*, 2021. URL <http://proceedings.mlr.press/v132/agarwal21b.html>.
- Agrawal, N., Shamsabadi, A. S., Kusner, M. J., and Gascón, A. QUOTIENT: two-party secure neural network training and prediction. In *Proceedings of the 2019 ACM SIGSAC Conference on Computer and Communications Security, CCS 2019, London, UK, November 11-15, 2019*, 2019. URL <https://doi.org/10.1145/3319535.3339819>.
- Beaver, D. Precomputing oblivious transfer. In *Advances in Cryptology - CRYPTO '95, 15th Annual International Cryptology Conference, Santa Barbara, California, USA, August 27-31, 1995, Proceedings*, volume 963, 1995. URL [https://doi.org/10.1007/3-540-44750-4\\_8](https://doi.org/10.1007/3-540-44750-4_8).
- Bonawitz, K. A., Eichner, H., Grieskamp, W., Huba, D., Ingerman, A., Ivanov, V., Kiddon, C., Konečný, J., Mazzocchi, S., McMahan, B., Overvelde, T. V., Petrou, D., Ramage, D., and Roselander, J. Towards federated learning at scale: System design. In *Proceedings of Machine Learning and Systems 2019, MLSys 2019, Stanford, CA, USA, March 31 - April 2, 2019*, 2019. URL <https://proceedings.mlsys.org/book/271.pdf>.
- Cheon, J. H., Kim, A., Kim, M., and Song, Y. S. Homomorphic encryption for arithmetic of approximate numbers. In *Advances in Cryptology - ASIACRYPT 2017 - 23rd International Conference on the Theory and Applications of Cryptology and Information Security, Hong Kong, China, December 3-7, 2017, Proceedings, Part I*, volume 10624, 2017. URL [https://doi.org/10.1007/978-3-319-70694-8\\_15](https://doi.org/10.1007/978-3-319-70694-8_15).
- Chillotti, I., Gama, N., Georgieva, M., and Izabachène, M. TFHE: fast fully homomorphic encryption over the torus. *J. Cryptol.*, 33(1), 2020. URL <https://doi.org/10.1007/s00145-019-09319-x>.
- Cho, M., Ghodsi, Z., Reagen, B., Garg, S., and Hegde, C. Sphynx: Relu-efficient network design for private inference. [abs/2106.11755](https://arxiv.org/abs/2106.11755), 2021. URL <https://arxiv.org/abs/2106.11755>.
- Clevert, D., Unterthiner, T., and Hochreiter, S. Fast and accurate deep network learning by exponential linear units (elus). In *4th International Conference on Learning Representations, ICLR 2016, San Juan, Puerto Rico, May 2-4, 2016, Conference Track Proceedings*, 2016. URL <http://arxiv.org/abs/1511.07289>.
- Coleman, C., Narayanan, D., Kang, D., Zhao, T., Zhang, J., Nardi, L., Bailis, P., Olukotun, K., Ré, C., and Zaharia, M. Dawnbench: An end-to-end deep learning benchmark and competition. *NIPS ML Systems Workshop*, 2017. URL <https://dawn.cs.stanford.edu/benchmark/papers/nips17-dawnbench.pdf>.
- Costan, V. and Devadas, S. Intel SGX Explained. *IACR Cryptol. ePrint Arch.*, 2016. URL <http://eprint.iacr.org/2016/086>.
- Fan, J. and Vercauteren, F. Somewhat practical fully homomorphic encryption. *IACR Cryptol. ePrint Arch.*, 2012. URL <http://eprint.iacr.org/2012/144>.
- Garimella, K., Jha, N. K., and Reagen, B. Sisyphus: A Cautionary Tale of Using Low-Degree Polynomial Activations in Privacy-Preserving Deep Learning. [abs/2107.12342](https://arxiv.org/abs/2107.12342), 2021. URL <https://arxiv.org/abs/2107.12342>.
- Ge, R., Lee, J. D., and Ma, T. Learning one-hidden-layer neural networks with landscape design. In *6th International Conference on Learning Representations, ICLR 2018, Vancouver, BC, Canada, April 30 - May 3, 2018, Conference Track Proceedings*.
- Gentry, C. Fully homomorphic encryption using ideal lattices. In *Proceedings of the 41st Annual ACM Symposium on Theory of Computing, STOC 2009, Bethesda, MD, USA, May 31 - June 2, 2009*, 2009. URL <https://doi.org/10.1145/1536414.1536440>.
- Ghodsi, Z., Veldanda, A. K., Reagen, B., and Garg, S. Cryptonas: Private inference on a relu budget. In *Advances in Neural Information Processing Systems 33: Annual Conference on Neural Information Processing Systems 2020, NeurIPS 2020, December 6-12, 2020, virtual*, 2020. URL <https://proceedings.neurips.cc/paper/2020/hash/c519d47c329c79537fbb2b6f1c551ff0-Abstract.html>.
- Gilad-Bachrach, R., Dowlin, N., Laine, K., Lauter, K. E., Naehrig, M., and Wernsing, J. Cryptonets: Applying neural networks to encrypted data with high throughput and accuracy. In *Proceedings of the 33rd International Conference on Machine Learning, ICML 2016, New York City, NY, USA, June 19-24, 2016*, volume 48, 2016. URL <http://proceedings.mlr.press/v48/gilad-bachrach16.html>.

- He, K., Zhang, X., Ren, S., and Sun, J. Deep residual learning for image recognition. In *2016 IEEE Conference on Computer Vision and Pattern Recognition, CVPR 2016, Las Vegas, NV, USA, June 27-30, 2016*, 2016a. URL <https://doi.org/10.1109/CVPR.2016.90>.
- He, K., Zhang, X., Ren, S., and Sun, J. Identity mappings in deep residual networks. In *Computer Vision - ECCV 2016 - 14th European Conference, Amsterdam, The Netherlands, October 11-14, 2016, Proceedings, Part IV*, volume 9908, 2016b. URL [https://doi.org/10.1007/978-3-319-46493-0\\_38](https://doi.org/10.1007/978-3-319-46493-0_38).
- Hendrycks, D. and Gimpel, K. Bridging nonlinearities and stochastic regularizers with gaussian error linear units. *CoRR*, abs/1606.08415, 2016. URL <http://arxiv.org/abs/1606.08415>.
- Hesamifard, E., Takabi, H., and Ghasemi, M. Deep neural networks classification over encrypted data. In *Proceedings of the Ninth ACM Conference on Data and Application Security and Privacy, CODASPY 2019, Richardson, TX, USA, March 25-27, 2019*, 2019. URL <https://doi.org/10.1145/3292006.3300044>.
- Ishiyama, T., Suzuki, T., and Yamana, H. Highly accurate CNN inference using approximate activation functions over homomorphic encryption. In *2020 IEEE International Conference on Big Data (IEEE BigData 2020), Atlanta, GA, USA, December 10-13, 2020*, 2020. URL <https://doi.org/10.1109/BigData50022.2020.9378372>.
- Jaderberg, M., Dalibard, V., Osindero, S., Czarnecki, W. M., Donahue, J., Razavi, A., Vinyals, O., Green, T., Dunning, I., Simonyan, K., Fernando, C., and Kavukcuoglu, K. Population based training of neural networks. *CoRR*, abs/1711.09846, 2017. URL <http://arxiv.org/abs/1711.09846>.
- Jha, N. K., Ghodsi, Z., Garg, S., and Reagen, B. Deepreduce: Relu reduction for fast private inference. In *Proceedings of the 38th International Conference on Machine Learning, ICML 2021, 18-24 July 2021, Virtual Event*, volume 139, 2021. URL <http://proceedings.mlr.press/v139/jha21a.html>.
- Juvekar, C., Vaikuntanathan, V., and Chandrakasan, A. P. GAZELLE: A low latency framework for secure neural network inference. In *27th USENIX Security Symposium, USENIX Security 2018, Baltimore, MD, USA, August 15-17, 2018*, 2018. URL <https://www.usenix.org/conference/usenixsecurity18/presentation/juvekar>.
- Klambauer, G., Unterthiner, T., Mayr, A., and Hochreiter, S. Self-normalizing neural networks. In *Advances in Neural Information Processing Systems 30: Annual Conference on Neural Information Processing Systems 2017, December 4-9, 2017, Long Beach, CA, USA*, 2017. URL <https://proceedings.neurips.cc/paper/2017/hash/5d44ee6f2c3f71b73125876103c8f6c4-Abstract.html>.
- Konečný, J., McMahan, H. B., Yu, F. X., Richtárik, P., Suresh, A. T., and Bacon, D. Federated learning: Strategies for improving communication efficiency. *CoRR*, 2016. URL <http://arxiv.org/abs/1610.05492>.
- Lee, J., Lee, E., Lee, J., Kim, Y., Kim, Y., and No, J. Precise approximation of convolutional neural networks for homomorphically encrypted data. *CoRR*, abs/2105.10879, 2021. URL <https://arxiv.org/abs/2105.10879>.
- Liu, J., Juuti, M., Lu, Y., and Asokan, N. Oblivious neural network predictions via minion transformations. In *Proceedings of the 2017 ACM SIGSAC Conference on Computer and Communications Security, CCS 2017, Dallas, TX, USA, October 30 - November 03, 2017*, 2017. URL <https://doi.org/10.1145/3133956.3134056>.
- Lokhande, V. S., Tasneeyapant, S., Venkatesh, A., Ravi, S. N., and Singh, V. Generating accurate pseudo-labels in semi-supervised learning and avoiding overconfident predictions via hermite polynomial activations. In *2020 IEEE/CVF Conference on Computer Vision and Pattern Recognition, CVPR 2020, Seattle, WA, USA, June 13-19, 2020*, pp. 11432–11440, 2020. URL [https://openaccess.thecvf.com/content\\_CVPR\\_2020/html/Lokhande\\_Generating\\_Accurate\\_Pseudo-Labels\\_in\\_Semi-Supervised\\_Learning\\_and\\_Avoiding\\_Overconfident\\_Predictions\\_CVPR\\_2020\\_paper.html](https://openaccess.thecvf.com/content_CVPR_2020/html/Lokhande_Generating_Accurate_Pseudo-Labels_in_Semi-Supervised_Learning_and_Avoiding_Overconfident_Predictions_CVPR_2020_paper.html).
- Lou, Q. and Jiang, L. HEMET: A homomorphic-encryption-friendly privacy-preserving mobile neural network architecture. In *Proceedings of the 38th International Conference on Machine Learning, ICML 2021, 18-24 July 2021, Virtual Event*, 2021. URL <http://proceedings.mlr.press/v139/lou21a.html>.
- Lou, Q., Shen, Y., Jin, H., and Jiang, L. SAFENet: A secure, accurate and fast neural network inference. In *9th International Conference on Learning Representations, ICLR 2021, Virtual Event, Austria, May 3-7, 2021*, 2021.

- Mishra, P., Lehmkuhl, R., Srinivasan, A., Zheng, W., and Popa, R. A. Delphi: A cryptographic inference service for neural networks. In *29th USENIX Security Symposium, USENIX Security 2020, August 12-14, 2020*, 2020. URL <https://www.usenix.org/conference/usenixsecurity20/presentation/mishra>.
- Misra, D. Mish: A self regularized non-monotonic neural activation function. *CoRR*, abs/1908.08681, 2019. URL <http://arxiv.org/abs/1908.08681>.
- Ngabonziza, B., Martin, D., Bailey, A., Cho, H., and Martin, S. Trustzone explained: Architectural features and use cases. In *2nd IEEE International Conference on Collaboration and Internet Computing, CIC 2016, Pittsburgh, PA, USA, November 1-3, 2016*. IEEE Computer Society, 2016. URL <https://doi.org/10.1109/CIC.2016.065>.
- Obla, S., Gong, X., Aloufi, A., Hu, P., and Takabi, D. Effective activation functions for homomorphic evaluation of deep neural networks. *IEEE Access*, 8, 2020. URL <https://doi.org/10.1109/ACCESS.2020.3017436>.
- Panigrahi, A., Shetty, A., and Goyal, N. Effect of activation functions on the training of overparametrized neural nets. In *8th International Conference on Learning Representations, ICLR 2020, Addis Ababa, Ethiopia, April 26-30, 2020*, 2020.
- Rabin, M. O. How to exchange secrets with oblivious transfer. *IACR Cryptol. ePrint Arch.*, 2005. URL <http://eprint.iacr.org/2005/187>.
- Ramachandran, P., Zoph, B., and Le, Q. V. Searching for activation functions. In *6th International Conference on Learning Representations, ICLR 2018, Vancouver, BC, Canada, April 30 - May 3, 2018, Workshop Track Proceedings*, 2018.
- Riazi, M. S., Samragh, M., Chen, H., Laine, K., Lauter, K. E., and Koushanfar, F. XONN: xnor-based oblivious deep neural network inference. In *28th USENIX Security Symposium, USENIX Security 2019, Santa Clara, CA, USA, August 14-16, 2019*, 2019. URL <https://www.usenix.org/conference/usenixsecurity19/presentation/riazi>.
- Russakovsky, O., Deng, J., Su, H., Krause, J., Satheesh, S., Ma, S., Huang, Z., Karpathy, A., Khosla, A., Bernstein, M. S., Berg, A. C., and Fei-Fei, L. Imagenet large scale visual recognition challenge. *Int. J. Comput. Vis.*, 115(3), 2015. URL <https://doi.org/10.1007/s11263-015-0816-y>.
- SEAL. Microsoft SEAL (release 3.6). <https://github.com/Microsoft/SEAL>, November 2020. Microsoft Research, Redmond, WA.
- Shamir, A. How to share a secret. *Commun. ACM*, 22(11), 1979. URL <http://doi.acm.org/10.1145/359168.359176>.
- Simonyan, K. and Zisserman, A. Very deep convolutional networks for large-scale image recognition. In *3rd International Conference on Learning Representations, ICLR 2015, San Diego, CA, USA, May 7-9, 2015, Conference Track Proceedings*, 2015. URL <http://arxiv.org/abs/1409.1556>.
- Thaine, P., Gorbunov, S., and Penn, G. Efficient evaluation of activation functions over encrypted data. In *2019 IEEE Security and Privacy Workshops, SP Workshops 2019, San Francisco, CA, USA, May 19-23, 2019*, 2019. URL <https://doi.org/10.1109/SPW.2019.00022>.
- Veidinger, L. On the numerical determination of the best approximations in the chebyshev sense. *Numerische Mathematik*, 2(1), 1960. URL <https://link.springer.com/content/pdf/10.1007/BF01386215.pdf>.
- Yao, A. C. Protocols for secure computations (extended abstract). In *23rd Annual Symposium on Foundations of Computer Science, Chicago, Illinois, USA, 3-5 November 1982*. IEEE Computer Society, 1982. URL <https://doi.org/10.1109/SFCS.1982.38>.
- Yao, A. C. How to generate and exchange secrets (extended abstract). In *27th Annual Symposium on Foundations of Computer Science, Toronto, Canada, 27-29 October 1986*, 1986. URL <https://doi.org/10.1109/SFCS.1986.25>.
- Zoph, B. and Le, Q. V. Neural architecture search with reinforcement learning. In *5th International Conference on Learning Representations, ICLR 2017, Toulon, France, April 24-26, 2017, Conference Track Proceedings*, 2017.

## A. An illustration of the Delphi protocol

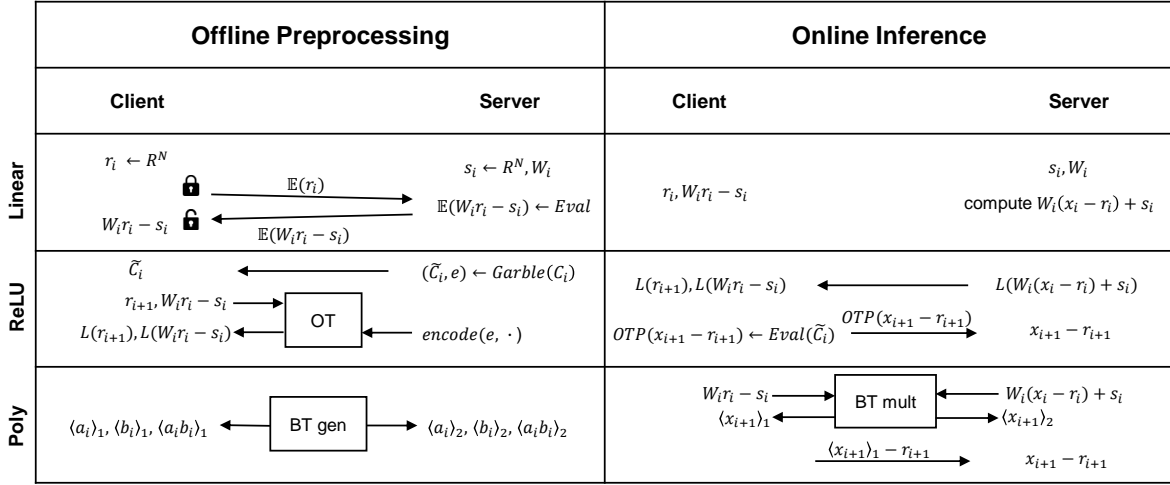

Figure 5. An illustration of the Delphi protocol. Delphi uses LHE for convolution and FC in linear layers, and GC for ReLU or BT for polynomial activation in non-linear layers.

## B. Parameters for cryptographic primitives

**Choice of prime for prime field:** In Delphi, the underlying MPC cryptographic primitives have two additional parameters: i) *prime number for prime field* and ii) *data representation*. All the operations in the cryptographic primitives are defined on this data representation and prime finite field. This parameter setting ensures no overflow and underflow to occur in a single layer evaluation. These parameters are key factor defines the cost of MPC primitives. Throughout this paper, we have used the latest version of Delphi’s configuration(Del, 2021), which uses 41-bit prime of 2061584302081 for prime finite fields and 11bit fixed-point data representation.