

# Sherman: A Write-Optimized Distributed B<sup>+</sup>Tree Index on Disaggregated Memory

Qing Wang  
Tsinghua University  
Beijing, China

Youyou Lu  
Tsinghua University  
Beijing, China

Jiwu Shu  
Tsinghua University  
Beijing, China

## Abstract

Memory disaggregation architecture physically separates CPU and memory into independent components, which are connected via high-speed RDMA networks, greatly improving resource utilization of databases. However, such an architecture poses unique challenges to data indexing in databases due to limited RDMA semantics and near-zero computation power at memory-side. Existing indexes supporting disaggregated memory either suffer from low write performance, or require hardware modification.

This paper presents SHERMAN, a write-optimized distributed B<sup>+</sup>Tree index on disaggregated memory that delivers high performance with commodity RDMA NICs. SHERMAN combines RDMA hardware features and RDMA-friendly software techniques to boost index write performance from three angles. First, to reduce round trips, SHERMAN coalesces dependent RDMA commands by leveraging in-order delivery property of RDMA. Second, to accelerate concurrent accesses, SHERMAN introduces a hierarchical lock that exploits on-chip memory of RDMA NICs. Finally, to mitigate write amplification, SHERMAN tailors the data structure layout of B<sup>+</sup>Tree with a two-level version mechanism. Our evaluation shows that, SHERMAN is one order of magnitude faster in terms of both throughput and 99th percentile latency on typical write-intensive workloads, compared with state-of-the-art designs.

## 1 Introduction

The popularity of in-memory databases (e.g., SAP HANA [5]) and in-memory computing (e.g., Spark [74]) catalyzes ever-increasing demands for memory in modern datacenters. However, datacenters today suffer from low memory utilization (< 65%) [29, 45, 55, 61], which results from imbalanced memory usages across a sea of servers. In response, academia and industry are working towards a new hardware architecture called *memory disaggregation*, where CPU and memory are *physically* separated into two network-attached components – compute servers and memory servers [16, 23, 30, 36, 38, 39, 42, 49, 55, 56, 65, 71, 78, 79]. With

This is the pre-print version of our SIGMOD'22 paper.

Permission to make digital or hard copies of all or part of this work for personal or classroom use is granted without fee provided that copies are not made or distributed for profit or commercial advantage and that copies bear this notice and the full citation on the first page. Copyrights for components of this work owned by others than ACM must be honored. Abstracting with credit is permitted. To copy otherwise, or republish, to post on servers or to redistribute to lists, requires prior specific permission and/or a fee. Request permissions from [permissions@acm.org](mailto:permissions@acm.org).

SIGMOD '22, June 20–25, 2022, Philadelphia, PA, USA

© 2022 Association for Computing Machinery.

ACM ISBN XXX-XXX-XXX-XXX-XXX/18/06...\$15.00

<https://doi.org/XXX.XXX/XXX.XXX>

memory disaggregation, CPU and memory can scale independently and different applications share a global disaggregated memory pool efficiently.

Since almost all CPUs are assembled on compute servers under the memory disaggregation architecture, memory servers have near-zero computation power, which highlights the challenge that how compute servers access disaggregated memory residing on memory servers. Fortunately, RDMA (Remote Direct Memory Access), a fast network technique, allows compute servers to *directly access* disaggregated memory unmediated by memory servers' computation power with a single-digit-microsecond level latency, becoming an essential building block of memory disaggregation architecture [16, 23, 55, 79].

In this paper, we explore how to design a high-performance tree index, a key pillar of database systems, on disaggregated memory. We first revisit existing RDMA-based tree indexes and examine their applicability on disaggregated memory. Several RDMA-based tree indexes rely on remote procedure calls (RPCs) to handle write operations<sup>1</sup> [47, 54]; they are ill-suited for disaggregated memory due to near-zero computation power of memory servers. For tree indexes that can be deployed on disaggregated memory, they also have some critical limitations: ① Some indexes using RDMA one-sided verbs for all index operation [81] (we call it *one-sided approach*); they can deliver high performance for read operations, but suffer from low throughput and high latency in terms of write operations, especially in high-contention scenarios (< 0.4 Mops with ~20ms tail latency, §3.1). ② Other indexes bake write operations into SmartNICs or customized hardware [6], which brings high TCO (total cost of ownership) and cannot be deployed in datacenters in a large scale immediately.

Our goal is designing a tree index on disaggregated memory that can *deliver high performance for both read and write operations with commodity RDMA NICs*. To this end, we further analyze what makes one-sided approach inefficient in write operations, and find out three major causes. First, due to limited semantics of one-sided verbs, modifying an index node (e.g., tree node in B<sup>+</sup>Tree) always requires multiple round trips (i.e., lock, read, write, unlock), inducing high latency and further making conflicting requests more likely to be blocked. Second, the locks used for resolving write-write conflicts are slow and experience performance collapse under high-contention scenarios. This is because ① at the hardware level, NICs adopt expensive concurrency control to ensure atomicity between RDMA atomic commands, where each command needs two PCIe transactions. ② at the software level, such locks always trigger unnecessary retries, which consumes RDMA IOPS, and do not provide fairness, which leads to high tail latency. Third, the layout

<sup>1</sup>In this paper, we refer *lookup* and *range query* as read operations, and refer *insertion* (include update existing keys) and *deletion* as write operations.

of index data structure incurs severe write amplification. Due to coarse-grained consistency check mechanisms (e.g., using checksum to protect a whole tree node), a small piece of modification will result in large-sized write-back across the network.

Motivated by the above analysis, we propose SHERMAN<sup>2</sup>, a write-optimized distributed B<sup>+</sup>Tree index on disaggregated memory. The key idea of SHERMAN is *combining RDMA hardware features and RDMA-friendly software techniques to reduce round trips, accelerate lock operations, and mitigate write amplification*. SHERMAN spreads B<sup>+</sup>Tree nodes across a set of memory servers, and compute servers perform all index operations via RDMA one-sided verbs purely. SHERMAN uses a classic approach for concurrency control: lock-free search with versions to resolve read-write conflicts and exclusive locks to resolve write-write conflicts [44, 81].

To reduce round trips, SHERMAN introduces a command combination technique. Based on the observation that RDMA NICs already provide in-order delivery property, this technique allows client threads to issue dependent RDMA commands (e.g., write-back and lock release) simultaneously, letting NICs at memory servers reflect them into disaggregated memory in order.

To accelerate lock operations, we design a *hierarchical on-chip lock (HOCL)* for SHERMAN. HOCL is structured into two parts: global lock tables on memory servers, and local lock tables on compute servers. Global lock tables and local lock tables coordinate conflicting lock requests between compute servers and within a compute server, respectively. Global lock tables are stored in the on-chip memory of RDMA NICs, thus eliminating PCIe transactions of memory servers and further delivering extremely high throughput for RDMA atomic commands (~110 Mops). Within a compute server, before trying to acquire a global lock on memory servers, a thread must acquire the associated local lock, so as to avoid a large amount of unnecessary remote retries. Moreover, by adopting wait queues, local lock tables improve fairness between conflicting lock requests. Based on local lock tables, a thread can hand over its acquired lock to another thread directly, reducing at least one round trip for acquiring global locks.

To mitigate write amplification, SHERMAN tailors the leaf node layout of B<sup>+</sup>Tree. First, entries in leaf node are *unsorted*, so as to eschew shift operations upon insertion/deletion. Second, to support lock-free search while avoiding write amplification, we introduce a *two-level version mechanism*. In addition to using a pair of *node-level versions* to detect the inconsistency of the whole leaf node, we embed a pair of *entry-level versions* into each entry, which ensures entry-level integrity. For insertion/deletion operations without split/merging events, only entry-sized data is written back, thus saving network bandwidth and making the most of the extremely high IOPS of small RDMA messages.

We evaluate SHERMAN using a set of benchmarks. Under write-intensive workloads, SHERMAN achieves much better performance than FG [81], a state-of-the-art distributed B<sup>+</sup>Tree supporting disaggregated memory. Specifically, in common skewed workloads, SHERMAN delivers one order of magnitude performance improvement in terms of both throughput and 99th percentile latency. Meanwhile, a SHERMAN tree can be accessed concurrently by more than 500 client

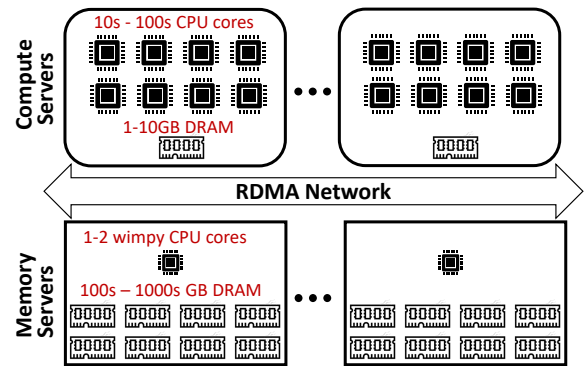

Figure 1: Architecture of Memory Disaggregation.

threads, while providing peak throughput stably. For read-intensive workloads (i.e., 95% read operations), SHERMAN exhibits slightly higher throughput with 25% lower 99th percentile latency.

**Contributions.** The main contributions of this paper are:

- An analysis of existing tree indexes on disaggregated memory, demonstrating that the inefficiency of write operations in the one-sided approach stems from excessive round trips, slow synchronization primitives and write amplification (§3).
- The design and implementation of SHERMAN, a write-optimized B<sup>+</sup>Tree index on disaggregated memory, which boosts write performance by combining RDMA hardware features and RDMA-friendly software techniques (§4).
- A set of evaluations that demonstrate the high performance of SHERMAN under different workloads (§5).

## 2 Background

In this section, we provide the background on memory disaggregation (§2.1) and RDMA network (§2.2) briefly.

### 2.1 Memory Disaggregation

Traditional datacenters pack CPU and memory into the same hardware units (i.e., monolithic servers), leading to low memory utilization (< 65%) [29, 55, 61] and further increasing the TCO (total cost of ownership) of datacenters. To attack this problem, academia and industry are exploring a new hardware architecture called *memory disaggregation* [23, 42, 51, 55, 79], which is shown in Figure 1. In such an architecture, CPU and memory are physically separated into two different hardware units: compute servers (CSs) and memory servers (MSs). CSs own a mass of CPU cores (10s - 100s), but MSs host high-volume memory (100s - 1000s GB) with near-zero computation power. CPUs in CSs can directly access the disaggregated memory in MSs via high-speed RDMA networks (§2.2). With memory disaggregation, CPU and memory can scale independently and applications can pack resources in a more flexible manner, boosting resource utilization significantly.

To reduce remote accesses from CSs to MSs, CSs are always equipped with a small piece of memory as the local cache (1 - 10 GB). Moreover, MSs owns a small set of wimpy CPU cores (1 - 2) to support lightweight management tasks, such as network connection management and disaggregated memory allocation.

<sup>2</sup>The largest tree in the world is a giant sequoia called General Sherman, which stands in California's Sequoia National Park.

## 2.2 RDMA Network

RDMA network is the key enabler of memory disaggregation architecture. RDMA is increasingly popular in modern datacenters due to high bandwidth (e.g., 100Gbps) and low latency ( $\leq 2\mu\text{s}$ ) [21, 28]. RDMA provides two types of verbs, namely *two-sided verbs* and *one-sided verbs*, to applications. Two-sided verbs — RDMA\_SEND and RDMA\_RECV— are the same as traditional Linux socket interface: the sender generates messages via RDMA\_SEND, and the receiver pre-posts RDMA\_RECV commands as well as processes incoming messages. One-sided verbs, i.e., RDMA\_WRITE, RDMA\_READ and RDMA\_ATOMIC (RDMA\_FAA and RDMA\_CAS), operate directly on remote memory without involving the CPUs of receivers. The direct-access feature of one-sided verbs makes memory servers with near-zero computation power possible.

RDMA hosts communicate via queue pairs (QPs). A QP consists of a send queue and a receive queue, and a completion queue (CQ) is associated with the QP. A sender performs an RDMA command by posting the request on the send queue. On completion, the sender’s NIC writes a completion entry into the CQ, and the sender can know it by polling the CQ. RDMA supports three transport types: reliable connected (RC), unreliable connected (UC) and unreliable datagram (UD). SHERMAN uses RC, since it supports all one-sided verbs and is reliable; yet, RC requires one-to-one connections between QPs (i.e., a QP can only communicate with one QP).

Sparked by high performance and new one-sided verbs of RDMA, there is an active line of research in RDMA-based indexes [6, 21, 47, 54, 69, 81]. In this paper, we focus on distributed B<sup>+</sup>Tree index on disaggregated memory due to its elasticity and support for range query, but our ideas can be applied to other kinds of indexes.

## 3 Motivation

Designing a high-performance distributed tree index on disaggregated memory poses unique challenges. In this section, we first revisit two existing approaches — using one-sided verbs purely and extending RDMA interfaces — and reveal their respective issues (§3.1). Then, we analyze why using one-sided verbs is slow, which motivates the design of SHERMAN (§3.2).

### 3.1 Existing Approaches

With near-zero computation power at MS-side, we cannot delegate index operations to CPUs of MSs via remote procedure calls (RPCs), which is the main difference between memory disaggregation and traditional architectures. Existing work enables efficient lookup operations via lock-free search and caching mechanisms [21, 47, 67, 81], leading to a single RDMA\_READ in the ideal situation (i.e., cache hit). However, write operations are in a quandary due to their complex semantics; specifically, there are two avenues to design write operations, each of which has its own issues.

**3.1.1 Using One-sided Verbs Purely.** FG [81], a distributed RDMA-based B<sup>+</sup>Tree, is the only one tree index that completely leverages one-sided verbs to perform index write operations (so it can be deployed on disaggregated memory). Specifically, FG uses a B-link tree structure [40] and distributes tree nodes across different servers. For write operations, it adopts a lock-based approach, where tree node modification is protected by RDMA-based spinning locks;

		read-intensive		write-intensive	
		uniform	skew	uniform	skew
Throughput (Mop/s)		31.8	32.9	18.7	0.34
Latency ( $\mu\text{s}$ )	50th	4.9	4.7	9.5	10
	90th	6.4	6.2	14.3	68.7
	99th	14.9	15.3	19	19890

**Table 1: Index performance in one-sided approach (100 Gbps ConnectX-5 NICs, 8 MSs, 8 CSs with 176 client threads, 8/8-byte key/value, 1 billion key space). The performance collapses under *write-intensive* and *skew* setting.**

the locks leverage RDMA\_CAS for lock acquisition and RDMA\_FAA for lock release. For read operation, FG follows a lock-free search scheme, where threads fetch tree nodes via RDMA\_READ without holding locks and then check the consistency using checksum<sup>3</sup>. FG does not adopt any caching mechanism.

We conduct an experiment to evaluate FG’s performance. Since FG is not open-source, we implement it from scratch; we also cache internal tree nodes to reduce remote accesses. Table 1 shows the result, and we make two observations. First, in read-intensive workload (95% lookup and 5% insert/update), FG can achieve high throughput ( $> 30\text{Mops}$ ) and low 99th percentile latency ( $< 16\mu\text{s}$ ). Second, in write-intensive workload (50% lookup and 50% insert/update), FG delivers 18 Mops with 19 $\mu\text{s}$  tail latency under the *uniform* setting; yet, its performance collapses in case of skew setting, where the key popularity follows a Zipfian popularity with skewness 0.99: the throughput is only 0.34 Mops and corresponding tail latency is close to 20ms. This result is unacceptable, considering the two characteristics of today’s datacenter workloads: (i) It is well-known that data access patterns in the real-world follow a power-law distribution (i.e., Zipfian distribution) [8, 20, 31], where a small number of hot items receive frequent access. (ii) More and more applications exhibit write-intensive workloads, such as graph computation [26], parameter servers [41], and data warehousing system [64]. The inefficiency of write operations comes from excessive round trips, slow synchronization primitives and write amplification, which we will elaborate in §3.2.

**3.1.2 Extending RDMA Interfaces.** Another approach to designing tree indexes on disaggregated memory is extending RDMA interfaces. This approach offloads index write operations into memory servers’ NICs via SmartNICs or other customized hardware [6, 14, 22, 37, 43, 53, 59]. For example, by exploiting interface extensions (i.e., indirect addressing and notification), researchers propose HT-Tree (without implementation) [6], a hybrid index combining the hash table and tree. Yet, compared with commodity RDMA NICs, SmartNICs come at the price of *higher TCO (total cost of ownership)* and *lower performance*. More specifically, SmartNICs have much higher market price ( $\sim 5\times$ ) than that of commodity RDMA NICs at present [62]. As for performance, at 100Gbps network environment, StRoM [59], the state-of-the-art RDMA extensions using FPGA, has 2 $\times$  higher RDMA\_READ/RDMA\_WRITE round-trip latency (4 $\mu\text{s}$ ) against commodity RDMA NICs ( $\leq 2\mu\text{s}$ ).

<sup>3</sup>Private communication with authors of FG [81].

	Cell [47]	FaRM-Tree [54]	FG [81]	HT-Tree [6]	SHERMAN
<b>Read Performance</b>	Medium	High	Medium	High	High
<b>Write Performance</b>	Medium	High	Low	High	High
<b>No Hardware Modification</b>	✓	✓	✓	✗	✓
<b>Support Disaggregated Memory</b>	✗	✗	✓	✓	✓

**Table 2: A comparison of RDMA-based distributed tree indexes. All indexes use one-sided verbs for read operations. HT-Tree is a hybrid index combining the hash table and tree, and the remaining four are B<sup>+</sup>Tree structure. Cell executes write operations via RPCs; it only caches tree nodes near the root (at least four node levels above the leaf node level), so all read/write operations need four round trips at least. FaRM-Tree implements write operations by exploiting transactions, which in turn uses RPCs; it caches all internal tree nodes. FG leverages one-sided verbs to realize write operations, and does not use any caching mechanism. HT-Tree is a conceptual design without implementation, which relies on hardware extensions.**

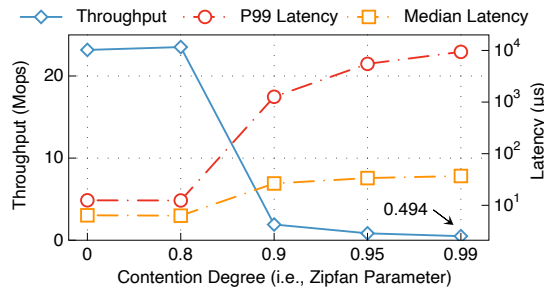

**Figure 2: Performance of RDMA-based exclusive locks (ConnectX-5 NICs, 100 Gbps). The system experiences performance collapse under high-contention settings.**

Table 2 shows a comparison of RDMA-based distributed tree indexes. Among them, Cell [47] and FaRM-Tree [54] use RPCs for write operations, so they cannot be deployed on disaggregated memory. FG [81] suffers from low write performance and HT-Tree [6] needs hardware modification. SHERMAN aims to achieve high performance (for both read and write operations) with commodity RDMA NICs on disaggregated memory.

### 3.2 Why One-sided Approach is Slow?

Using analysis and experiments, we show the inefficiency of write operations using one-sided verbs stems from *excessive round trips*, *slow synchronization primitives* and *write amplification*.

**3.2.1 Excessive Round Trips.** The most obvious cause of slow write operations is excessive round trips. For example, when modifying a tree node (not consider node split/merging), a client thread needs 4 round-trips: ①acquiring associated exclusive lock, ②reading the tree node, ③writing back the modified tree node ④and finally releasing the lock. Excessive round trips negatively impact write performance in two aspects. First, the latency of a single write operation is proportional to the number of round trips. Second, more round trips lead to the longer critical path, so conflicting write operations (i.e., requests targeting at the same tree node) are more likely to be blocked, degrading the concurrency performance.

**3.2.2 Slow Synchronization Primitives.** RDMA-based locks used in these indexes cannot provide sustainable performance under a

variety of workloads. We conduct an experiment to present performance issues of such locks. In the experiment, 154 threads across 7 CSc acquire/release 10240 locks residing in an MS; we choose the RDMA verbs used by FG [81], where RDMA\_CAS for lock acquisition and RDMA\_FAA for release. The access pattern follows Zipfian distribution and we vary Zipfian parameter to control the contention degree (0 is uniform setting, and 0.99 is the most common real-world scenario). Figure 2 shows the result. The system experiences performance collapse in terms of throughput and latency under high-contention settings. We attribute the performance collapse to the following three reasons.

**Expensive in-NIC concurrency control.** To guarantee correct atomicity semantic between RDMA\_ATOMIC commands targeting the same addresses, RDMA NICs adopt an internal locking scheme [34]. More specifically, a NIC maintains a certain number of buckets (e.g., 4096), and puts RDMA\_ATOMIC commands having the same certain bits in their destination addresses (e.g., 12 LSBs) into the same bucket. Commands in the same bucket are considered conflicting. An RDMA\_ATOMIC can not be executed until the previous conflicting commands are finished. Unfortunately, a single RDMA\_ATOMIC needs two PCIe transactions: ① reading data from CPU memory into the NIC and ② writing back after modification (② can be omitted in case of failed RDMA\_CAS). These PCIe transactions stretch the queue time of conflicting RDMA\_ATOMIC commands and thus degrade concurrent performance of RDMA\_ATOMIC commands, especially in high-contention workloads.

**Unnecessary retries.** When failing to acquire a lock, the client thread retries. Different from locks designed for shared memory with coherent cache, such retries in the RDMA environment require remote network accesses, squandering limited throughput of NICs in both senders and receivers. Retries can be eliminated via notification mechanisms, where a client thread is notified when the lock it wants to acquire has been released. Yet, notification needs remote CPU involvement, which is impractical on disaggregated memory, or specialized hardware like programmable switches [73].

**Lacking Fairness.** Existing locks in RDMA-based indexes do not take into account fairness between conflicting lock acquisition, thus starving some client requests and further inducing high tail latency.

**3.2.3 Write Amplification.** RDMA prefers small IO size, but indexes using one-sided verbs fail to exploit this feature. Figure 3 shows the throughput of outbound/inbound RDMA\_WRITE under varied

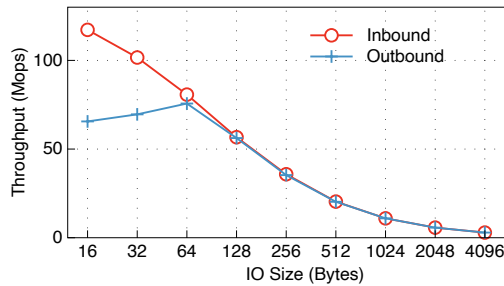

Figure 3: Performance of RDMA\_WRITE (ConnectX-5 NICs, 100 Gbps). RDMA\_WRITE prefers small IO size.

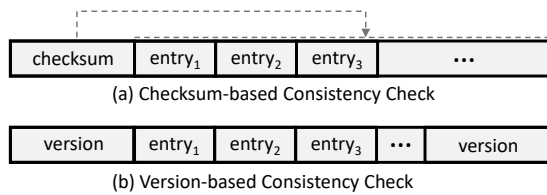

Figure 4: Two mechanisms to detect inconsistency of tree nodes. Both of them lead to write amplification.

IO sizes<sup>4</sup>. When IO size is less than or equal to 128 bytes, the throughput is more than 50 Mops; however, when IO size reaches to 256 bytes, NICs’s hardware bandwidth restricts throughput; our result is consistent with previous studies [68]. Yet, existing RDMA-based tree indexes always trigger large-sized RDMA\_WRITE, suffering from write amplification. This issue stems from two causes.

**Sorted layout.** A B<sup>+</sup>Tree keeps entries in each tree node sorted, to support traversal in internal nodes and binary search in leaf nodes. To ensure this property, when an entry is inserted/deleted to/from a node, all the entries on the right side of the insertion/deletion position need to be shifted. The shift operations cause extra data to be written via RDMA\_WRITE.

**Coarse-grained consistency check.** In order to read tree nodes in a lock-free way and detect incomplete data due to ongoing writes, two main consistency check mechanisms are proposed. In the first mechanism (Figure 4(a)), each node includes a checksum covering the whole node area (except the checksum itself) [46, 81]; the checksum is re-calculated when modifying the corresponding node, and is verified when reading the node. The other mechanism, namely version-based consistency check (Figure 4(b)), stores a version number at the start and end of each node [47]; when modifying a node via RDMA\_WRITE, the corresponding two version are incremented; a node’s content obtained via RDMA\_READ is consistent only when the two versions are the same<sup>5</sup>. Since the granularity of the above two mechanisms is tree node, any modification to part of the node area requires to write back the whole node (include the metadata, e.g., checksum and version), leading to severe write amplification.

<sup>4</sup>Outbound/inbound throughput: the throughput of sending/receiving RDMA\_WRITE commands from a NIC.

<sup>5</sup>Like Cell [47] and NAM-DB [75], we observe that the NIC reads data in increasing address order, so we omit per-cacheline version mechanisms used by FaRM [21].

## 4 Design

Motivated by our observations about root causes of inefficient write operations (§3.2), we design SHERMAN, a write-optimized distributed B<sup>+</sup>Tree index on disaggregated memory. In this section, we begin by presenting our design principles (§4.1), proceed to give an overview of SHERMAN (§4.2), and then describe our key techniques (§4.3–§4.5). Finally, we conduct a discussion (§4.6).

### 4.1 Design Principles

SHERMAN boosts the performance of write operations by reducing round trips, accelerating lock operations, and mitigating write amplification. It follows three core design principles.

**1) Seeking solutions from hardware first.** There are hiding features of RDMA NICs that pose opportunities for index design. In SHERMAN, we utilize ① on-chip memory exposed by NICs to accelerate lock operations, and ② in-order delivery guarantee of RC queue pairs to reduce round trips.

**2) Applying CS-side optimization when possible.** In the current multicore era, each compute server (CS) always launches a mass of client threads (10s - 100s) to manipulate an index concurrently, leaving a lot of design space for CS-side optimization. Within a CS, we leverage local lock tables to coordinate conflicting lock requests between threads, and locks can be handed over from a thread to another quickly. Besides, SHERMAN maintains CS-side index cache to reduce network accesses for tree traversal.

**3) Tailoring data structure layout to improve RDMA friendliness.** Disaggregated memory has unique profile: it is accessed via network (i.e., RDMA) rather than cache-coherent memory bus. Thus, it is necessary to tailor data structure layout of indexes to reap RDMA’s full potential. To this end, SHERMAN ① separates locks from the tree structure, to put them into NICs’ on-chip memory, and ② adopts entry-level versions as well as unsorted leaf nodes, to reduce IO size of RDMA\_WRITE commands.

### 4.2 Overview

Figure 5 shows the overall architecture and interactions of SHERMAN, which consists of a set of memory servers (MSs) and compute servers (CSs). MSs are equipped with massive memory where our SHERMAN tree resides. CSs run client threads that manipulate SHERMAN via specific interfaces (i.e., lookup, range query, insert and delete). Each MS and CS is equipped with RDMA NICs for network communication. Since the number of CPU cores continues to increase [9, 13, 72], we assume that there are always a host of client threads running within a CS (dozens or even hundreds). These client threads cooperatively execute system services (e.g., transaction processing), which needs SHERMAN for data indexing.

**4.2.1 B<sup>+</sup>Tree Structure.** SHERMAN is a B<sup>+</sup>Tree, where values are stored in leaf nodes. We record a sibling pointer for every leaf node and internal node as in the B-link tree [40]. Client threads can always reach a targeted node by following these sibling pointers in the presence of node split/merging, thus supporting concurrent operations efficiently. Every pointer in SHERMAN (i.e., child/sibling pointers) is 64-bit, which includes two parts: 16-bit MS unique identifier and 48-bit memory address within corresponding MS.

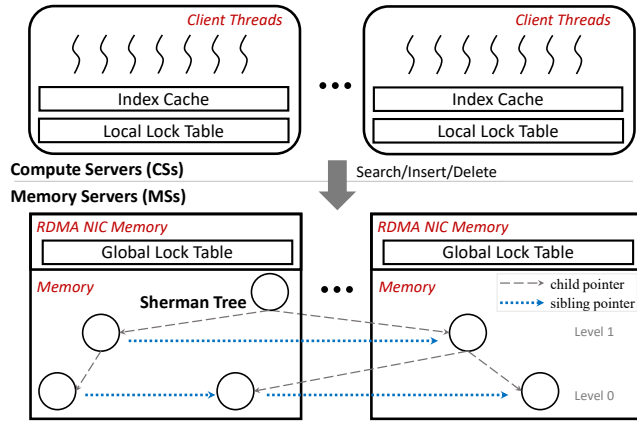

Figure 5: SHERMAN's architecture and interactions.

**4.2.2 Concurrency Control.** SHERMAN adopts lock-based write operations and lock-free read operations.

**Write-write conflicts.** SHERMAN uses *node-grained* exclusive locks to resolve write-write conflicts: before modifying a tree node, the client thread must acquire the associated exclusive lock. These exclusive locks are hierarchical: *local lock tables* at CS-side and *global lock tables* in on-chip memory of MSs' NICs (§4.3). Such a hierarchical structure avoids PCIe transactions at MS-side, reduces remote retries, and improves fairness.

**Read-write conflicts.** SHERMAN supports lock-free search, which leverages RDMA\_READ to fetch data residing in MSs without holding any lock. Moreover, SHERMAN uses versions to detect inconsistent data caused by concurrent writes. However, different from traditional mechanisms that use node-level versions, SHERMAN proposes a two-level version mechanism, which combines entry-level and node-level versions, to mitigate write amplification (§4.4).

**4.2.3 Cache Mechanism.** To reduce remote accesses in the tree traversal, SHERMAN adopts a cache mechanism. Each CS maintains an *index cache*, which only makes two types of internal nodes' copies: ❶ nodes above the leaf nodes (level 1 in Figure 5), and ❷ the highest two level of nodes (including root). A client thread firstly searches type ❶ cache. On hit, it fetches the targeted leaf node directly from MSs; otherwise, it searches type ❷ cache and then traverses to leaf nodes via remote accesses. The type ❷ is always cached; the type ❶ is structured as a lock-free skiplist, and applies power-of-two-choices [48] for evicting: selecting two cached nodes randomly and evicting the one least recently used. The index cache never induces data consistency issues for two reasons. First, internal nodes in B<sup>+</sup>Tree only contain location information, and the real data stored in leaf nodes are always accessed by RDMA commands. Second, in every node, we store a lower bound and upper bound for the set of keys that can appear in it (i.e., *fence keys* [27]), and we also store the level of the node (leaf nodes are level 0). When fetching a node from MSs, we check whether fence keys and node level are legal; if not, we invalidate the cache entry steering us to the wrong node and retry.

**4.2.4 Memory Management.** In each MS, we reserve a dedicated *memory thread* to manage disaggregated memory. The memory

```

1  MAX_LOCK_PRE_MS = 131072 # the number of locks in each MS
2  MAX_DEPTH = 4 # maximum number of consecutive handovers
3
4  def HOCL_Lock(addr):
5  idx = calculate_hash(addr) % MAX_LOCK_PRE_MS
6  l = LLT[addr.ms_id][idx]
7  if lock(l) == False: # get locks in LLT first
8      handover = False
9      # wait queue ensures first-come-first-served fairness
10     l.wait_queue.push(&handover)
11     while &handover != l.wait_queue.head():
12         continue
13     lock(l) # get locks in LLT first
14     l.wait_queue.pop()
15     if handover == True: # be handed over a lock
16         return
17 # get locks in GLT finally: RDMA_CAS(addr, compare, swap)
18 while RDMA_CAS(&GTL[addr.ms_id][idx], 0, cs_id) == False:
19     continue
20
21 def HOCL_Unlock(addr, combine_list):
22 idx = calculate_hash(addr) % MAX_LOCK_PRE_MS
23 l = LLT[addr.ms_id][idx]
24 handover = l.wait_queue.head()
25 if handover != None && (++l.handover_depth) <= MAX_DEPTH:
26     *handover = true # hand over lock to another thread
27 else:
28     l.handover_depth = 0
29     # collect an RDMA_WRITE command for lock (in GLT) release
30     # command's details: write 0 into 16-bit GLT[addr.ms_id][idx]
31     combine_list.push((0, &GLT[addr.ms_id][idx], 16bit))
32
33 unlock(l) # release locks in LLT
34 RDMA_WRITE combine_list # posting combined commands in list

```

Figure 6: Pseudo-code of hierarchical on-chip lock (HOCL). *combine\_list* is used to collect commands of RDMA\_WRITE that can be issued together (§4.5).

thread divides memory residing in corresponding MS into fixed-length chunks (i.e., 8MB). Client threads use a two-stage memory allocation scheme to obtain memory from MSs. A client thread first chooses an MS in a round-robin manner, and requests a free chunk from the MS's memory thread via RPCs. Then, it allocates memory space for tree nodes locally within the chunk. Such a two-stage scheme comes with two advantages. First, it avoids network communication for most allocation operations. Second, it mitigates processing overhead of memory thread significantly, which is necessary considering the near-zero computation power of MSs (i.e., 1-2 wimpy CPU cores). Note that the round-robin allocation may cause imbalanced accesses across MSs; we leave addressing this issue for future work.

For deallocation, since all memory space allocated in SHERMAN is fixed-length (i.e., node size) and each tree node owns its internal verification information (i.e., version, fence keys and node level), we do not need complex garbage collection strategies (e.g., epoch-based reclamation [21]). Instead, client threads only need to clear a *free* bit in a tree node before deallocating it; later requests that fetch the garbage node will realize the node has been freed.

### 4.3 Hierarchical On-Chip Lock

SHERMAN proposes hierarchical on-chip lock (HOCL) to improve concurrency performance. HOCL leverages on-chip memory of

NICs to avoid PCIe transactions at MS-side; it also maintains local locks at CS-side, to form a hierarchical structure, reduce retries and improve fairness. Moreover, locks can be handed over between client threads within the same CSs, thus saving at least one round trip. Figure 6 shows the pseudo-code of HOCL.

**On-chip lock table.** Current RDMA verbs support *device memory programming* [1]. Specifically, an RDMA NIC can expose a piece of its on-chip memory to the upper applications, which can be allocated and read/written by RDMA commands. The on-chip memory eliminates PCIe transaction at receiver-side, thus providing extremely high throughput (~110 Mops RDMA\_CAS). SHERMAN separates locks from tree nodes, and stores locks into on-chip memory at MS-side; each tree node is in the *same* MS as the lock protecting it. These locks in each MS are structured as an array, namely *global lock table* (GLT). When locking a tree node, the client thread first hashes the address of the tree node into an index number in the corresponding GLT (line 5 in Figure 6), and then issues an RDMA\_CAS command to the lock, which tries to change it from 0 to the 16-bit CS identifier atomically (line 18). For lock release, the client thread clears the lock via an RDMA\_WRITE command [68] (line 31, 34).

An important consideration of GLT is the on-chip memory size. In the NIC we use (i.e., ConnectX-5), 256KB on-chip memory is available. To accommodate more locks, we make the granularity of RDMA\_CAS finer (16 bits rather than 64 bits), by applying an infrequently used RDMA verb called *masked compare and swap* [2], which allows us to select a portion of 64-bit for RDMA\_CAS operations. Thus, an MS can maintain 131,072 locks in its GLT, enabling extremely high concurrency, particularly considering that we only lock at most one tree node at a time for a single write operation [52]. To the best of our knowledge, SHERMAN is the first RDMA-based system that leverages on-chip memory of commodity RDMA NICs. A concurrent work leverages NIC’s on-chip memory to accelerate network functions [50].

**Hierarchical structure.** SHERMAN maintains a *local lock table* (LLT) in each CS, to coordinate conflicting lock requests within the same CSs. The LLT stores a *local lock* for each lock of all GLTs. When a thread needs to lock a tree node, it first acquires the associated local lock in LLT (lines 6, 7, 13), and then acquires the associated lock in GLT; thus, conflicting lock requests from the same CSs are queued on the LLT at CS-side, avoiding unnecessary remote retries and thus saving RDMA IOPS. Moreover, each local lock in LLT is associated with a *wait queue*. A thread that cannot acquire a local lock in LLT pushes itself into the corresponding queue; the thread can learn if its turn has arrived by checking whether it is at the head of the queue (lines 8-14). The queue provides first-come-first-served fairness among threads within the same CSs. For lock release, the thread first releases the lock in GLT and then the local lock in LLT. Of note, an LLT consumes small local memory space of each CS; in our implementation, each local lock is 8-byte, so an LLT uses  $n$  MB space, where  $n$  is the number of MSs (i.e.,  $n * 8 * 131072$  bytes).

**Handover mechanism.** The hierarchical structure of HOCL enables a handover mechanism: handing over a lock from one client thread to another. When releasing a lock, if a thread finds out the lock’s wait queue is not empty, it will hand over the lock to the one at the head of the wait queue (lines 24-26). To avoid starving threads at other CSs, we limit the maximum number of consecutive handovers to 4. The thread that is handed over a lock no longer

```

1  NODE_SIZE # size of a tree node
2  ENTRY_SIZE # size of an entry
3
4  def Sherman_insert(key, value):
5      leaf_addr = index_cache.find(key) # search index cache
6
7      HOCL_Lock(leaf_addr) # lock the targeted leaf node
8      node = RDMA_READ(leaf_addr, NODE_SIZE) # RDMA_READ(remote_addr, size);
9      combine_list = {} # RDMA_WRITE task list: (buffer, addr, size)
10
11     if ∃i, node.entry[i].k == key || node.entry[i].k == None: #update/insert
12         # entry-level node modification
13         node.entry[i].{k, v} = {key, value}
14         node.entry[i].front_entry_ver++
15         node.entry[i].rear_entry_ver++
16         # collect a combined command for write-back of the entry in leaf node
17         combine_list.push({node, leaf_addr+offset(entry[i]), ENTRY_SIZE})
18     else # split
19         sibling = malloc(NODE_SIZE) # local buffer
20         sibling_addr = remote_alloc(NODE_SIZE) # allocate memory at MSs
21         node.sort().move_half_entries_to(sibling) # sort and move
22         sibling.{level, free} = {0, 0}
23         link(node, sibling) # link sibling and list: ... node ↔ sibling ...
24         update_fence_keys(node, sibling)
25         # node-level node modification
26         node.add(key, value)
27         node.front_node_ver++
28         node.rear_node_ver++
29         if leaf_addr.ms_id == sibling_addr.ms_id:
30             # collect a combined command for write-back of the sibling node
31             combine_list.push({sibling, sibling_addr, NODE_SIZE})
32         else:
33             RDMA_WRITE(sibling, sibling_addr, NODE_SIZE)
34             # collect a combined command for write-back of the leaf node
35             combine_list.push({node, leaf_addr, NODE_SIZE})
36
37     HOCL_Unlock(leaf_addr, combine_list) # unlock the targeted leaf
38     if sibling != None: # update internal nodes
39         insert_internal(sibling.entry[0].k, sibling_addr)

```

**Figure 7: Pseudo-code of SHERMAN’s insertion procedure. To simplify exposition, we omit the details on 1) traversing the tree in case of index cache miss and 2) following sibling pointers in case of concurrent node split/merging.**

needs remote accesses for acquiring the lock, thus saving at least one round trip (lines 15-16).

#### 4.4 Two-Level Version

To address the write amplification issue, SHERMAN incorporates a *two-level version mechanism*. First, SHERMAN uses unsorted leaf nodes so that shift operations upon insertion/deletion can be avoided. Unsorted leaf nodes complicate write operations in two aspects, as shown in Figure 7: (i) When looking up a key, the client thread needs to traverse the entire targeted leaf node (line 11). (ii) Before splitting a leaf node, the client thread must sort the entries in it (line 21). Given the microsecond level network latency, the added overhead is slight. Although previous work on persistent memory data structures leverages unsorted nodes to reduce persistence overhead [19, 70], we are the first one that uses it to alleviate write amplification of indexes on disaggregated memory.

Second, SHERMAN introduces *entry-level versions* to enable fine-grained consistency check, as shown in Figure 8. Specifically, in leaf nodes, each entry is surrounded by a pair of 4-bit *entry-level versions* (i.e., FEV and REV). In case of insertion without splitting, the

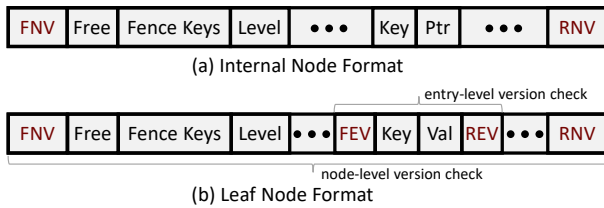

**Figure 8: The format of internal nodes and leaf nodes in SHERMAN. FNV/RNV is 4-bit front/rear node version; FEV/REV is 4-bit front/rear entry version. The entries in leaf nodes are unsorted. Entry-level versions are updated in case of insertion/deletion without split/merging, thus alleviating write amplification. Node-level versions are updated in case of node split/merging.**

associated entry-level versions are incremented and only the modified entry (includes FEV and REV) is written back via RDMA\_WRITE (lines 13-17 in Figure 7), thus evading write amplification. Also, a pair of 4-bit *node-level versions* (i.e., FNV and RNV) is stored at the begin and end of each leaf node, protecting the consistency at the node granularity. When splitting a leaf node, the client thread increments associated FNV and RNV, and writes back the whole node via RDMA\_WRITE (lines 26-33). Since internal nodes have a much lower modification frequency than leaf nodes, their format is standard: two node-level versions with a sorted layout. The extra memory space occupied by entry-level versions is acceptable: considering a B<sup>+</sup>Tree storing 8-byte key and 8-byte value, each key-value pair at leaf nodes needs extra 1-byte memory space for entry-level versions, consuming about 6% memory of all leaf nodes. **Lookup operation.** Our two-level version mechanism makes the lookup procedure different from the standard one. Figure 9 shows the pseudo-code of SHERMAN’s lookup procedure. After reading a leaf node from MSs, a client thread compares the two node-level versions first; mismatched versions indicate the read must be retried (lines 6-7). Then, the client thread locates the targeted entry and compares the two associated entry-level versions; if the comparison fails, the client thread needs to re-read the leaf node via RDMA\_READ (lines 10-11). Wraparounds of these 4-bit versions may cause inconsistency to be undetected: two versions match but one wraps around. To handle wraparounds, we measure the time of each RDMA\_READ command: if it takes more than 8 $\mu$ s (i.e.,  $2^4 \times 0.5$ , where  $0.5\mu$ s  $\ll$  the time of a single write operation), a retry is needed.

**Range query.** For a range query, the client thread issues multiple RDMA\_READ in parallel to fetch targeted leaf nodes, and then checks leaf nodes’ consistency in the same way as the lookup procedure. Of note, like FG, SHERMAN does not guarantee that a range query is atomic with concurrent write operations. If upper applications, e.g., transaction engine, need snapshot semantics for range queries, they must use other mechanisms to avoid phantom problem [63].

**Delete operation.** Delete operations experience a similar process as insert operations. In case of no leaf node merging, a delete operation only needs to clear the targeted entry (i.e., set key to *null*), increase the associated entry-level versions, and write back them via RDMA\_WRITE. When triggering node merging during a delete operation, SHERMAN uses node-level version to detect inconsistency.

```

1 def Sherman_lookup(key):
2   leaf_addr = index_cache.find(key)
3   retry:
4     node = RDMA_READ(leaf_addr, sizeof(node))
5     # node-level check
6     if node.front_node_ver != node.rear_node_ver:
7       goto retry
8     if  $\exists e, e$  in node && e.k == key: # find targeted entry
9       # entry-level check
10      if e.front_entry_ver != e.rear_entry_ver:
11        goto retry
12      return e.v
13  return None

```

**Figure 9: Pseudo-code of SHERMAN’s lookup procedure.**

## 4.5 Command Combination

To enforce ordering between dependent RDMA commands (e.g., writing back a node and then releasing the lock), existing RDMA-based indexes use an expensive approach: issuing the following RDMA command only after receiving the acknowledgement of the preceding one [81]. Yet, we observe that RDMA already provides a strong ordering property at the hardware level: in a reliable connected (RC) queue pair, RDMA\_WRITE commands are transmitted in the order that they are posted, and the NIC at receiver-side executes these commands in order [7, 77]. By leveraging this ordering property, SHERMAN combines multiple RDMA\_WRITE commands in a write operation, so as to reduce round trips.

There are two cases that SHERMAN combines multiple RDMA\_WRITE commands. First, since a tree node and its associated lock co-locate at the same MS, the write-back of tree node and lock release can be combined through a QP (lines 17, 35 in Figure 7 and line 31 in Figure 6), as opposed to issuing an unlock request after receiving acknowledgement of write-back; thus, one round trip is saved and the critical path shortens. Second, when a node (we call it A here) splits, we check whether the newly allocated sibling node belongs the same MS as A; if so, three RDMA\_WRITE commands can be combined together: ① write-back of the sibling node, ② write-back of A and ③ release of A’s lock (line 31 in Figure 7).

Client threads issue these combined commands to the targeted MS by posting a linked list of them in one call (line 34 in Figure 6); such a combination not only saves round trips, but also reduces CPU usages and PCIe transactions. In addition, we only mark the last one in the list as signaled (i.e., generate a completion entry to the corresponding CQ), so NIC-initiated DMAs for writing completion entries can be reduced [34].

## 4.6 Discussion

**Generality of RDMA features used by SHERMAN.** SHERMAN leverages two RDMA hardware features: in-order property and on-chip memory. The in-order property is defined in RDMA specification [7]. The on-chip memory is supported in Mellanox’s ConnectX-5 NICs (announced in 2016) and above [1]. Note that ConnectX-5 NICs and above are already widely used in datacenters; for example, Alibaba uses ConnectX-5 NICs to build a performant production-level cloud storage system [25].

**Generality of SHERMAN’s techniques.** SHERMAN’s techniques can be applied to other kinds of indexes. Specifically, any lock-based



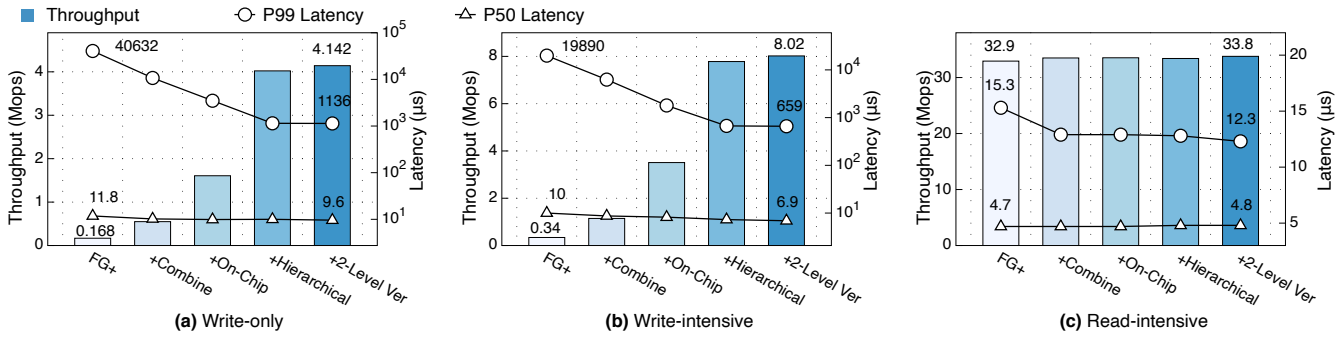

Figure 10: Contributions of techniques to performance (skewed workloads, skewness=0.99).

indexes (e.g., bucket hash table) can use HOCL and command combination to improve concurrency performance and reduce round trips. If an index follows lock-free search scheme, the two-level version mechanism is a good choice to mitigate write amplification.

## 5 Evaluation

In this section, we evaluate SHERMAN to answer following questions:

- How does SHERMAN perform under different workloads, and how do the different techniques employed in SHERMAN contribute to overall performance (§5.2 and §5.3)?
- How scalable is SHERMAN when varying client threads (§5.4)?
- How SHERMAN’s techniques impact internal metrics, e.g., the number of round trips and write amplification (§5.5)?
- How do parameters of SHERMAN, e.g., key size and cache index size, impact performance (§5.6)?
- How does HOCL perform (§5.7)?

### 5.1 Setup

**5.1.1 Hardware Platform.** Since memory disaggregation hardware is unavailable, we use a cluster of commodity, off-the-shelf servers to emulate MSs and CSs by limiting their usages of CPUs and memory [55]. Our cluster consists of 8 servers, each of which is equipped with 128GB DRAM, two 2.2GHz Intel Xeon E5-2650 v4 CPUs (24 cores in total), and one 100Gbps Mellanox ConnectX-5 NIC, installed with CentOS 7.7.1908 (Linux kernel version is 3.10.0). All these servers are connected with a Mellanox MSB7790-ES2F switch. For Mellanox ConnectX-5 NICs, the versions of driver and firmware are ofed 4.7-3.2.9.0 and 16.26.4012, respectively. Due to the limited size of our cluster, we emulate each server as one MS and one CS. Each MS owns 64GB DRAM and 2 CPU cores, and each CS owns 1GB DRAM and 22 CPU cores.

**5.1.2 Compared Systems.** FG [81] is the only distributed B<sup>+</sup>Tree that supports disaggregated memory. Since FG is not open-source, we implement it from scratch. For fair comparison, we add necessary optimizations to it: (i) index cache for reducing remote accesses, (ii) using RDMA\_WRITE to release lock rather than expensive atomic verb RDMA\_FAA. In order to distinguish our modified version of FG from the original one, we call it FG+ in the evaluation. The performance of FG+ is higher than that reported in FG paper [81].

Workload	Insert	Lookup	Range Query
write-only	100%		
write-intensive	50%	50%	
read-intensive	5%	95%	
range-only			100%
range-write	50%		50%

Table 3: Workloads.

**5.1.3 Workloads.** We explore different aspects of the systems by using YCSB workloads [20]. We use five types of read-write ratio, as shown in Table 3. Note that insert operations include updating existing keys (about 2/3 of all insert operations).

There are two types of key popularity: *uniform* and *skewed*. In uniform workloads, all keys have the same probability of being accessed. Skewed workloads follow a Zipfian access distribution (Zipfian parameter, i.e., skewness, is 0.99 by default), which is common in production environments [18, 20].

Unless otherwise stated, all the experiments are conducted with 8 MSs and 8 CSs. Each CS owns 500MB index cache, and launches 22 client threads (176 in total in our cluster). For each experiment, we bulkload the tree with 1 billion entries (8-byte key, 8-byte value) 80% full, then perform specified workloads. The size of a tree node (i.e., internal node and leaf node) is 1KB. All plots in this section present the average of 3 or more runs.

### 5.2 Overall Performance

To analyze SHERMAN’s performance, we break down the performance gap between FG+ and SHERMAN through applying each technique one by one. Figure 10 and Figure 11 show the results under skewed and uniform workloads, respectively.

In these two figures, **+Combine** stand for command combination technique. **+On-Chip** and **+Hierarchical** are two design parts of HOCL: leveraging on-chip memory of NICs to store locks, and hierarchical structure with handover mechanism, respectively. **+2-Level Ver** represents two-level version mechanism, and shows the final performance of SHERMAN.

**5.2.1 Skewed Workloads.** We make following observations from Figure 10. First, in both write-only and write-intensive workloads, SHERMAN has much higher throughput and lower latency against FG+. Specifically, in write-only workloads, SHERMAN achieves 24.7× higher throughput with 1.2× lower median latency (50p latency)

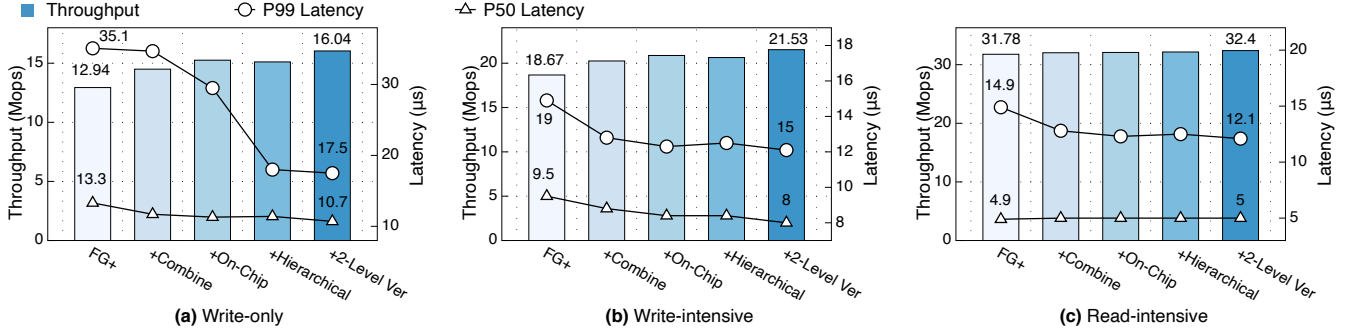

Figure 11: Contributions of techniques to performance (uniform workloads).

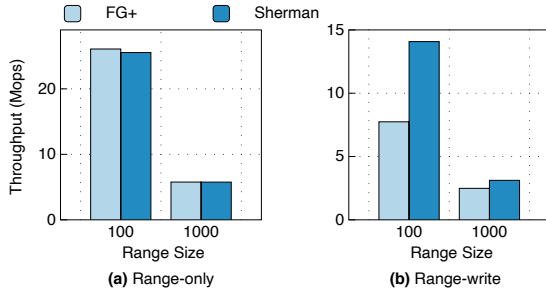

Figure 12: Performance of range query.

and  $35.8\times$  lower 99th percentile latency (99p latency). In write-intensive workloads, SHERMAN achieves  $23.6\times$  higher throughput with  $1.4\times/30.2\times$  lower 50p/99p latency.

Second, all techniques contribute to the high write efficiency of SHERMAN. Here we analyze each technique in terms of write-intensive workloads (write-only workloads has the same conclusions): ① Command combination improves the throughput by  $3.37\times$  and reduces the 50p/99p latency by  $1.14\times/3.18\times$ , since it saves at least one round trip for each insert operation (two round trips in case of some tree split events) and further shortens the critical paths, decreasing the probability that conflicting requests are blocked. ② By putting locks into on-chip memory of NICs, SHERMAN gains  $3.06\times$  and  $3.48\times$  improvement in terms of throughput and 99p latency, respectively. This is because on-chip memory avoids PCIe transactions of lock operations at MS-side, which provides extremely high throughput for RDMA atomic verbs and thus can absorb more failed RDMA\_CAS for retries. Moreover, since the PCIe transactions are excluded from the critical path of RDMA\_CAS, conflicting RDMA\_CAS commands experience shorter queueing time in NICs, ensuring lower tail latency (i.e., 99p latency). ③ Introducing hierarchical lock structure to SHERMAN brings  $2.22\times$  higher throughput,  $1.12\times$  lower 50p latency and  $2.68\times$  lower 99p latency, which comes from the following three reasons. First, by acquiring local locks before remote ones, unnecessary RDMA\_CAS retries from the same CSs are avoided, mitigating the consumption of RDMA NICs' limited IOPS. Second, the local locks in each CS guarantee first-come-first-served fairness by maintaining wait queues, thus lowering tail latency due to starvation. Third, the handover mechanism saves one round trip opportunistically. ④ Two-level version mechanism does not bring considerable throughput improvement

(only  $3\%$ ), since the major bottleneck is concurrent conflicts rather than RDMA IOPS at this time; the 50p latency is reduced by  $400\text{ns}$  (from  $7.3\mu\text{s}$  to  $6.9\mu\text{s}$ ), since smaller RDMA\_WRITE IO size has shorter PCIe DMA time at both CS-side and MS-side.

Third, in read-intensive workloads (Figure 10(c)), SHERMAN does not present considerable performance improvement, as expected, since all techniques we proposed aims to boost performance of write operations. Yet, there are still two points worth noting here: ① By saving round trips for 5% insert operations, command combination reduces 99p latency from  $15.3\mu\text{s}$  to  $12.9\mu\text{s}$ . ② SHERMAN increases the 50p latency by  $100\text{ns}$  ( $2\%$ ), we contribute it to unsorted leaf node layout, which causes traversal of the entire leaf node even for non-existing keys.

**5.2.2 Uniform Workloads.** As shown in Figure 11, compared with FG+, SHERMAN delivers  $1.24\times$  and  $1.15\times$  higher throughput in write-only and write-intensive workloads, respectively. These improvements mainly come from command combination and two-level version. Command combination saves round trips, so each client thread can execute more insert operations per second; two-level version reduces IO size of RDMA\_WRITE from node size to entry size, thus giving full play to the RDMA's characteristics of extremely high small IO rate. HOCL is designed for high-contention scenarios (i.e., skewed workloads), so it does not increase throughput in uniform workloads. As for latency, SHERMAN reduces 50p/99p latency by  $1.24\times/2.01\times$  and  $1.19\times/1.27\times$  in write-only and write-intensive workloads, respectively, which mainly is contributed to command combination and HOCL: command combination saves round trips, and HOCL saves PCIe transaction time in MS-side as well as improves the fairness of locks.

### 5.3 Range Query Performance

In this experiment, we evaluate the performance of range query by using range-only and range-write workloads. The targeted range follows the skewed access pattern. Figure 12(a) shows the performance of range-only workloads, from which we make two observations. First, when the range size equals 100, FG+ outperforms SHERMAN by  $2\%$ . This is because the unsorted leaf layout in SHERMAN leads to unnecessary scans when targeted leaf nodes are partially occupied. Second, as range size grows (i.e., 1000), the throughput of SHERMAN and FG+ drops and is almost the same, since network bandwidth becomes the bottleneck.

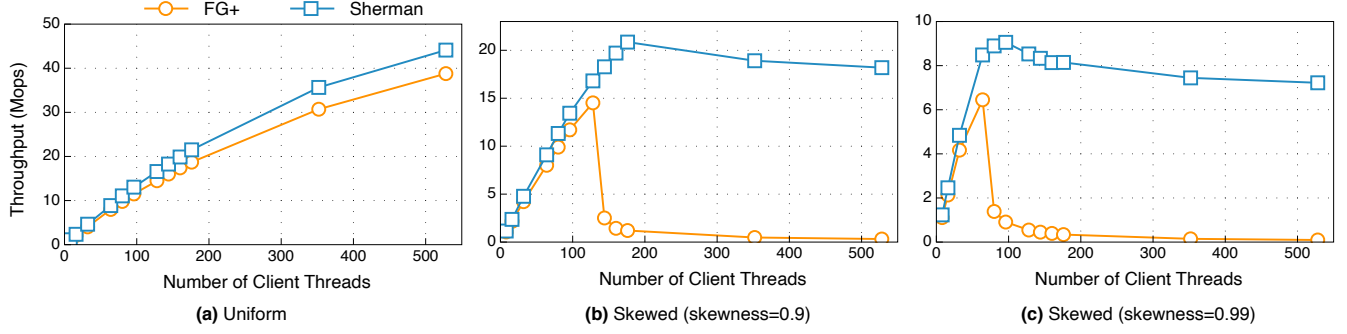

Figure 13: Scalability of SHERMAN (write-intensive workloads).

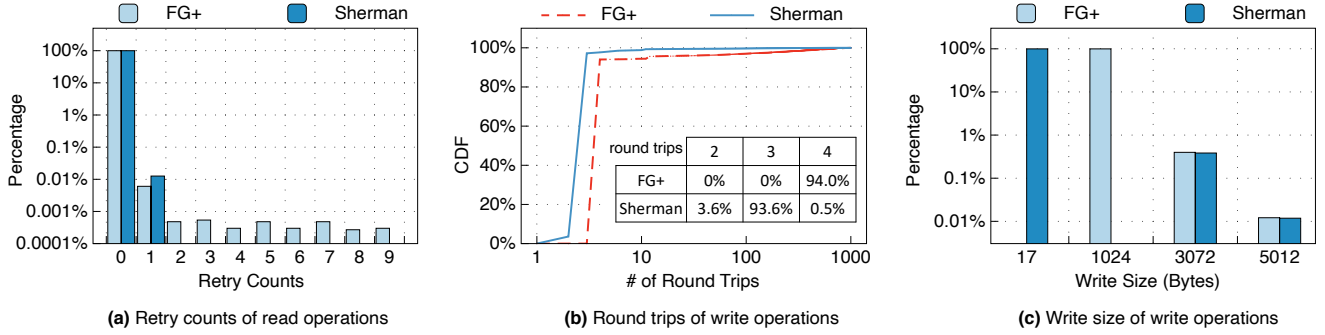

Figure 14: In-depth analysis using internal metrics (write-intensive workloads, skewness=0.99).

Figure 12(b) shows the throughput of range query, under range-write workloads. Half of the client threads issue insert operations, and the other half issue range query operations. SHERMAN outperforms FG+ by up to 1.82 $\times$ . This is because SHERMAN’s write operations save a considerable quantity of network resources for range query operations. Specifically, HOCL significantly decreases the number of RDMA messages via lock handover and the hierarchical structure; two-level version mechanism reduces the RDMA\_WRITE IO size from node level to entry level.

### 5.4 Scalability

In this experiment, we test the scalability of SHERMAN by varying the number of client threads that concurrently manipulate the tree. Due to the limited CPU cores in CSs, i.e., 22  $\times$  8 in total, we bind multiple coroutines to every core of CSs; coroutines are implemented via Boost C++ library. Each coroutine stands for a client thread, which issues insert/lookup requests; a coroutine yields after initiating RDMA commands, allowing other coroutines to do useful work. We use write-intensive workloads. Figure 13 shows the results under uniform and skewed scenarios. We make the following observations.

First, in uniform workloads, both SHERMAN and FG+ can scale well. In case of 528 client threads, SHERMAN achieves 44 Mops, 1.14 $\times$  the throughput of FG+. The improvement mainly comes from two-level version mechanism: by writing back leaf nodes in a smaller granularity, more RDMA bandwidth are saved for RDMA\_READ commands and lock operations.

Second, in skewed workloads, a higher contention degree (i.e., larger skewness value) leads to lower peak throughput. Specifically, SHERMAN achieves 21 Mops peak throughput in case of 0.9 skewness, which is 1.44 $\times$  higher than that of FG+; and 9 Mops in case of 0.99 skewness, which is 1.4 $\times$  higher than that of FG+. This is because the more serious the contention, the more likely concurrent write operations to be blocked, degrading the peak throughput.

Third, in skewed workloads, SHERMAN can provide sustainable throughput when more client threads are added; yet, FG+ experiences performance collapse. We attribute the SHERMAN’s stable performance to a combination of all techniques we proposed, as stated in §5.2.1.

### 5.5 In-Depth Analysis

In order to unveil detailed information of SHERMAN, we collect statistics for various internal metrics, including the number of read retries, the number of round trips, and write size, to perform an in-depth analysis. We choose write-intensive workloads with a skewed access pattern (skewness=0.99).

**5.5.1 Retry Counts.** Figure 14(a) shows retry counts of lookup operations. We make two observations. First, for FG+ and SHERMAN, 99.98% of lookup operations do not require retries. This is because PCIe links already guarantee a certain level of atomicity: a PCIe read transaction is strictly ordered after prior PCIe write transactions [33]. Such a guarantee circumvents most interleaving accesses between read and write operations. Second, FG+ experiences a few multiple times (e.g., 9) of read retries. This is because FG+ does not

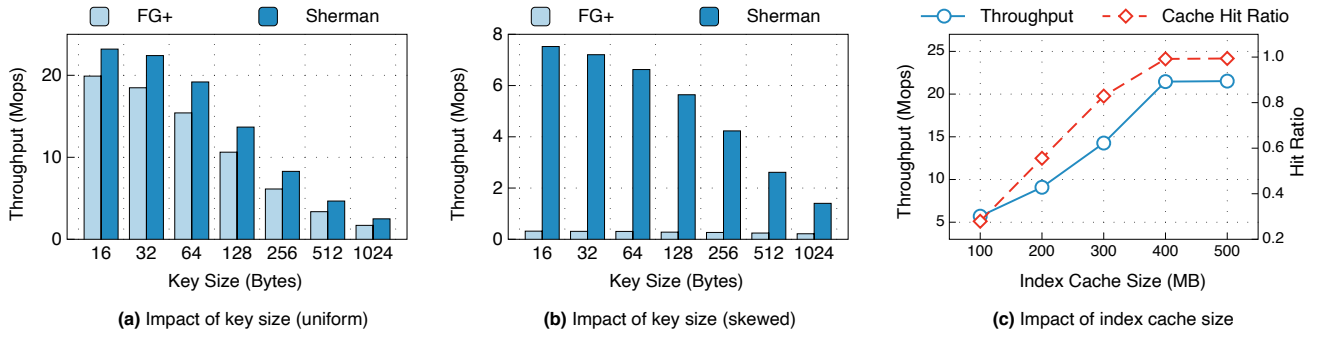

Figure 15: Sensitivity analysis.

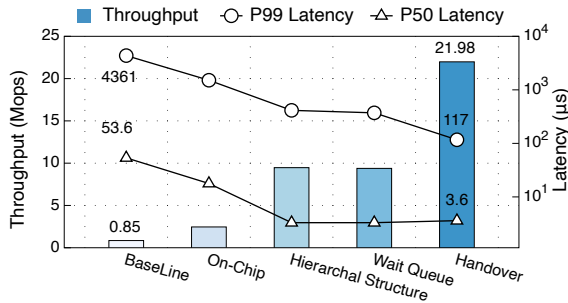

Figure 16: Performance of HOCL with skewed pattern.

adopt SHERMAN’s two-level mechanism, causing larger RDMA IO size with longer DMA times at MS-side and thus increasing the likelihood that lookup operations fetch inconsistent tree nodes.

**5.5.2 The Number of Round Trips.** Figure 14(b) reports the cumulative distribution of write operations’ round trips. We make three observations. First, 94% of write operations need 4 round trips in FG+, while 93.6% need 3 round trips in SHERMAN. The reason is that SHERMAN uses command combination technique to coalesce write-back and lock release. Second, 3.6% of write operations in SHERMAN only need 2 round trips, since HOCL’s handover mechanism saves one round trip opportunistically. Third, for FG+, the 99th percentile of round trips is 453, which explains why its tail latency is so high (§5.2.1). In contrast, SHERMAN leverages HOCL to avoid massive lock retries and offer fairness; thus, its 99th percentile of round trips is 11, ensuring low tail latency.

**5.5.3 Write Size.** Figure 14(c) shows the write size of write operations. Since we use skewed workloads which features strong access locality, only about 0.4% of write operations trigger node splits, inducing large than 1KB writes. As shown in the figure, for write operations without node splits, SHERMAN only needs to write back 17 bytes (i.e., 16-byte key-value pair along with two 4-bit versions) by using two-level version mechanism, rather than writing back the whole tree node, thus eliminating write amplification.

## 5.6 Sensitivity Analysis

**5.6.1 Key Size.** Here we study how key size affects SHERMAN’s performance. Since SHERMAN embeds keys in tree nodes, in this experiment we fix the number of entries in a leaf node to 32 by

changing the size of leaf nodes. We bulkload the tree with 200 million entries 80% full and then perform write-intensive workloads. Figure 15(a) shows the throughput under uniform workloads. We make two observations. First, as the key size grows, the performance of both SHERMAN and FG+ drops. This is because every index operation needs to fetch the whole leaf node via RDMA\_READ, and thus larger node size (caused by larger key size) consumes more network bandwidth for each index operation. Second, as the key size grows from 16B to 1KB, the performance advantage of SHERMAN over FG+ increases from 1.17× to 1.47×, since two-level version in SHERMAN can save more bandwidth for larger tree nodes.

Figure 15(b) presents the throughput under skewed workloads. Since FG+ suffers from low throughput in high-contention scenarios, the increasing key size does not affect its throughput. When the key size is 1KB, SHERMAN still outperforms FG+ by 1.4×.

**5.6.2 Index Cache Size.** In order to study how the index cache size affects the performance of SHERMAN, we conduct an experiment with uniform and write-intensive workloads. Figure 15(c) shows the result. As the cache index capacity grows, both SHERMAN’s performance and cache hit ratio increase. For large dataset (i.e., 1 billion entries in our evaluation), a 400MB index cache can bring a cache hit rate close to 98%, which demonstrates the efficiency of our index cache design.

## 5.7 HOCL Performance

In this experiment, we evaluate the performance of HOCL. We launch 176 threads across 8 CSs to acquire/release 10240 locks stored in an MS. These operations follow a skewed access pattern with 0.99 skewness. Figure 16 shows the result. Putting locks into on-chip memory improves the throughput by 2.89× and reduces the 50p/99p latency by 3.01×/2.88×, since on-chip memory eliminates PCIe transactions for RDMA\_CAS commands at MS-sides, making processing units in NICs more efficient and shortening queuing time of conflicting commands. By introducing local lock tables at CS-sides and further forming a hierarchical structure, we gain 3.85×, 5.39×, and 3.65× improvement in throughput, 50p latency and 99p latency, respectively. This is because a thread can issue RDMA\_CAS to acquire a remote lock only when no thread at the same CS holds this lock, avoiding a large amount of failed RDMA\_CAS retries and further saving RDMA IOPS. Wait queues provide first-come-first-served fairness within a CS; as a result, the 99p latency is reduced from 414μs to 372μs. Handover mechanism further improve the

throughput by 2.34× and reduces the 99p latency by 3.19×, since by handing over locks from a thread to another thread locally, remote locking via RDMA\_CAS commands can be avoided, accelerating lock acquisition.

## 6 Related Work

To our knowledge, SHERMAN is the first tree index on disaggregated memory that can deliver high performance for both read and write operations with commodity RDMA NICs. We discuss two aspects of related work: RDMA-based databases and memory disaggregation.

### 6.1 RDMA-based Databases

Fast RDMA network spurs researchers to build new distributed databases. FaRM [21, 54] provides general distributed transactions by using RDMA for messaging and direct-access to remote memory. DrTM [69] leverages the strong consistency between RDMA and HTM (hardware transaction memory) to transform a distributed transaction into a local one. FaSST [35] argues that two-sided unreliable verbs have higher scalability than one-sided verbs; thus, FaSST proposes a fast RPC framework using two-sided unreliable RDMA and builds an OCC-based distributed transaction engine on it. Chiller [76] proposes a contention-centric partitioning scheme to improve throughput of RDMA-based transactions. Aurogon [32] redesigns timestamp ordering protocols with RDMA to reduce aborts. Other databases exploit RDMA to support distributed join operations [10, 11]. These above systems can use SHERMAN to index data, or employ HOCL to boost their concurrency performance.

Other distributed database systems assume a NAM (network-attached memory) architecture that *logically* decouples compute and memory servers and uses RDMA for communication [12, 75, 81]. Specifically, NAM-DB [75] designs a scalable global counter technique to support snapshot isolation efficiently. Compared with NAM architecture, memory disaggregation assumed by SHERMAN is more radical: it decouples compute and memory *physically*, contributing to an ideal independent scaling of compute and memory. Furthermore, memory disaggregation poses more challenges to database design: near-zero computation power at memory-side and small local memory at compute-side.

Active-Memory [77] leverages RDMA to replicate data in a failure atomic way. It uses ordering property of RDMA to combine undo logging and in-place update in a single network round trip. Inspired by Active-Memory, SHERMAN combines RDMA commands within an index write operation to reduce round trips.

DFI [60] abstracts low-level RDMA verbs and provides a set of flexible interfaces (e.g., multicast, global sequencers) to support data-intensive applications such as OLAP. It will be interesting if DFI exposes on-chip memory of RDMA NICs to applications, to accelerate some interfaces such as global sequencers.

RDMA also accelerates indexing in distributed databases. As discussed in §3, most RDMA-based indexes do not support disaggregated memory. FG [81] is the first RDMA-based index that can be deployed on disaggregated memory, since it uses one-sided verbs for all index operations. RACE [82] is an extendible hashing index on disaggregated memory that supports lock-free accesses and remote resizing. SHERMAN rethinks how to combine RDMA

hardware features and RDMA-friendly software designs to improve tree indexes' performance on disaggregated memory.

Finally, some researchers design general distributed shared memory (DSM) with RDMA [15, 57, 58, 66], to support database components such as transaction engine. Specifically, GAM [15] provides a unified global memory abstraction and maintains coherence between cache copies via a directory-based protocol. Concordia [66] leverages programmable switches to mitigate cache coherence overhead. Hotpot [57] and TH-DPMS [58] support data durability by using persistent memory. Index cache in SHERMAN exploits the structure of B<sup>+</sup>Tree to invalidate stale cached entries lazily without any coherence protocols.

### 6.2 Memory Disaggregation

Memory disaggregation is not a new idea: Lim et al. [42] proposed it more than a decade ago, to attack the problem of a growing imbalance in compute-to-memory-capacity ratio. Recently, memory disaggregation regains attention for two reasons. First, large-scale companies report the low memory utilization in datacenters [29, 55, 61]. Second, high-speed RDMA network makes performance of remote accesses close to that of local accesses. Gao et al. [24] find that, under a memory disaggregation architecture, 40-100Gbps network bandwidth and 3-5μs network latency can maintain application-level performance.

Many recent academic efforts have been devoted to making memory disaggregation practical. LegoOS [55] designs a distributed operating system to manage disaggregated resources. pDPM [62] explores how to deploy disaggregated persistent memory (PM) in an efficient manner. Rao et al. [51] demonstrate that, for Spark SQL, memory disaggregation is promising with currently available network hardware. Zhang et al. [79] evaluate two production DBMSs, PostgreSQL and MonetDB, on disaggregated memory using TPC-H benchmark; they find that in several scenarios, memory disaggregation can boost performance of databases. LegoBase [80] and PolarDB Serverless [17] co-design database and memory disaggregation, achieving faster failure recovery speed than traditional architectures. SHERMAN focuses on building a fast B<sup>+</sup>Tree index on disaggregated memory.

Industry is proposing memory disaggregation hardware. HPE's "The Machine" [3, 36] connects a set of SoCs to a shared memory pool via photonic network. IBM's ThymesisFlow [49] leverages OpenCAPI [4] to enable CPUs directly access remote disaggregated memory without software involvement. VMware uses cache coherence mechanisms to track applications' memory accesses, reducing data amplification of disaggregated memory [16].

## 7 Conclusion

We proposed and evaluated SHERMAN, an RDMA-based B<sup>+</sup>Tree index on disaggregated memory. SHERMAN introduces a set of techniques to boost write performance and outperforms existing solutions. We believe SHERMAN demonstrates that combining RDMA hardware features and RDMA-friendly software designs can enable a high-performance index on disaggregated memory.

## References

- [1] 2021. Device Memory Programming. <https://docs.mellanox.com/display/OFEDv502180/Programming#Programming-DeviceMemoryProgramming>.
- [2] 2021. Enhanced Atomic Operations. <https://docs.mellanox.com/display/OFEDv502180/Advanced+Transport#AdvancedTransport-EnhancedAtomicOperations>.
- [3] 2021. The Machine: A New Kind of Computer. <https://www.hpl.hp.com/research/systems-research/themachine/>.
- [4] 2021. OpenCAPI. <https://opencapi.org/>.
- [5] 2021. SAP HANA. <https://www.sap.com/products/hana.html>.
- [6] Marcos K. Aguilera, Kimberly Keeton, Stanko Novakovic, and Sharad Singhal. 2019. Designing Far Memory Data Structures: Think Outside the Box. In *Proceedings of the Workshop on Hot Topics in Operating Systems (Bertinoro, Italy) (HotOS '19)*. Association for Computing Machinery, New York, NY, USA, 120–126. <https://doi.org/10.1145/3317550.3321433>
- [7] InfiniBand Trade Association et al. 2015. InfiniBand™ Architecture Specification Volume 1 Release 1.3 (General Specifications).
- [8] Berk Atikoglu, Yuehai Xu, Eitan Frachtenberg, Song Jiang, and Mike Paleczny. 2012. Workload Analysis of a Large-Scale Key-Value Store. In *Proceedings of the 12th ACM SIGMETRICS/PERFORMANCE Joint International Conference on Measurement and Modeling of Computer Systems (London, England, UK) (SIGMETRICS '12)*. Association for Computing Machinery, New York, NY, USA, 53–64. <https://doi.org/10.1145/2254756.2254766>
- [9] Tiemo Bang, Norman May, Iliia Petrov, and Carsten Binnig. 2020. The Tale of 1000 Cores: An Evaluation of Concurrency Control on Real(Ly) Large Multi-Socket Hardware. In *Proceedings of the 16th International Workshop on Data Management on New Hardware (Portland, Oregon) (DaMoN '20)*. Association for Computing Machinery, New York, NY, USA, Article 3, 9 pages. <https://doi.org/10.1145/3399666.3399910>
- [10] Claude Barthels, Gustavo Alonso, Torsten Hoefler, Timo Schneider, and Ingo Müller. 2017. Distributed Join Algorithms on Thousands of Cores. *Proc. VLDB Endow.* 10, 5 (2017), 517–528. <https://doi.org/10.14778/3055540.3055545>
- [11] Claude Barthels, Simon Loesing, Gustavo Alonso, and Donald Kossmann. 2015. Rack-Scale In-Memory Join Processing using RDMA. In *Proceedings of the 2015 ACM SIGMOD International Conference on Management of Data, Melbourne, Victoria, Australia, May 31 - June 4, 2015*, Timos K. Sellis, Susan B. Davidson, and Zachary G. Ives (Eds.). ACM, 1463–1475. <https://doi.org/10.1145/2723372.2750547>
- [12] Carsten Binnig, Andrew Crotty, Alex Galakatos, Tim Kraska, and Erfan Zamanian. 2016. The End of Slow Networks: It's Time for a Redesign. *Proc. VLDB Endow.* 9, 7 (March 2016), 528–539. <https://doi.org/10.14778/2904483.2904485>
- [13] Shekhar Borkar. 2007. Thousand core chips: a technology perspective. In *Proceedings of the 44th annual design automation conference*. 746–749.
- [14] Matthew Burke, Sowmya Dharanipragada, Shannon Joyner, Adriana Szekeres, Jacob Nelson, Irene Zhang, and Dan R. K. Ports. 2021. PRISM: Rethinking the RDMA Interface for Distributed Systems. In *Proceedings of the ACM SIGOPS 28th Symposium on Operating Systems Principles (Virtual Event, Germany) (SOSP '21)*. Association for Computing Machinery, New York, NY, USA, 228–242. <https://doi.org/10.1145/3477132.3483587>
- [15] Qingchao Cai, Wentian Guo, Hao Zhang, Divyakant Agrawal, Gang Chen, Beng Chin Ooi, Kian-Lee Tan, Yong Meng Teo, and Sheng Wang. 2018. Efficient Distributed Memory Management with RDMA and Caching. *Proc. VLDB Endow.* 11, 11 (2018), 1604–1617. <https://doi.org/10.14778/3236187.3236209>
- [16] Irina Calciu, M. Talha Imran, Ivan Puddu, Sanidhya Kashyap, Hasan Al Maruf, Onur Mutlu, and Aasheesh Kolli. 2021. Rethinking software runtimes for disaggregated memory. In *ASPLOS '21: 26th ACM International Conference on Architectural Support for Programming Languages and Operating Systems, Virtual Event, USA, April 19-23, 2021*, Tim Sherwood, Emery Berger, and Christos Kozyrakis (Eds.). ACM, 79–92. <https://doi.org/10.1145/3445814.3446713>
- [17] Wei Cao, Yingqiang Zhang, Xinjun Yang, Feifei Li, Sheng Wang, Qingda Hu, Xuntao Cheng, Zongzhi Chen, Zhenjun Liu, Jing Fang, Bo Wang, Yuhui Wang, Haiqing Sun, Ze Yang, Zhushi Cheng, Sen Chen, Jian Wu, Wei Hu, Jianwei Zhao, Yusong Gao, Songlu Cai, Yunyang Zhang, and Jiawang Tong. 2021. PolarDB Serverless: A Cloud Native Database for Disaggregated Data Centers. In *Proceedings of the 2021 International Conference on Management of Data (SIGMOD '21)*. Association for Computing Machinery, New York, NY, USA, 2477–2489. <https://doi.org/10.1145/3448016.3457560>
- [18] Jiqiang Chen, Liang Chen, Sheng Wang, Guoyun Zhu, Yuan Yuan Sun, Huan Liu, and Feifei Li. 2020. HotRing: A Hotspot-Aware In-Memory Key-Value Store. In *18th USENIX Conference on File and Storage Technologies (FAST 20)*. USENIX Association, Santa Clara, CA, 239–252. <https://www.usenix.org/conference/fast20/presentation/chen-jiqiang>
- [19] Shimin Chen, Phillip B. Gibbons, and Suman Nath. 2011. Rethinking Database Algorithms for Phase Change Memory. In *CIDR*.
- [20] Brian F. Cooper, Adam Silberstein, Erwin Tam, Raghu Ramakrishnan, and Russell Sears. 2010. Benchmarking Cloud Serving Systems with YCSB. In *Proceedings of the 1st ACM Symposium on Cloud Computing (Indianapolis, Indiana, USA) (SoCC '10)*. Association for Computing Machinery, New York, NY, USA, 143–154. <https://doi.org/10.1145/1807128.1807152>
- [21] Aleksandar Dragojević, Dushyanth Narayanan, Orion Hodson, and Miguel Castro. 2014. FaRM: Fast Remote Memory. In *Proceedings of the 11th USENIX Conference on Networked Systems Design and Implementation (Seattle, WA) (NSDI'14)*. USENIX Association, USA, 401–414.
- [22] Daniel Firestone, Andrew Putnam, Sambhrama Mundkur, Derek Chiou, Alireza Dabagh, Mike Andrewartha, Hari Angepat, Vivek Bhanu, Adrian Caulfield, Eric Chung, Harish Kumar Chandrappa, Simesh Chaturmohta, Matt Humphrey, Jack Lavier, Norman Lam, Fengfen Liu, Kalin Ovtcharov, Jitu Padhye, Gautham Popuri, Shachar Rindell, Tejas Sapre, Mark Shaw, Gabriel Silva, Madhan Sivakumar, Nisheeth Srivastava, Anshuman Verma, Qasim Zuhair, Deepak Bansal, Doug Burger, Kushagra Vaid, David A. Maltz, and Albert Greenberg. 2018. Azure Accelerated Networking: SmartNICs in the Public Cloud. In *Proceedings of the 15th USENIX Conference on Networked Systems Design and Implementation (Renton, WA, USA) (NSDI'18)*. USENIX Association, USA, 51–64.
- [23] Peter X. Gao, Akshay Narayan, Sagar Karandikar, Joao Carreira, Sangjin Han, Rachit Agarwal, Sylvia Ratnasamy, and Scott Shenker. 2016. Network Requirements for Resource Disaggregation. In *Proceedings of the 12th USENIX Conference on Operating Systems Design and Implementation (Savannah, GA, USA) (OSDI'16)*. USENIX Association, USA, 249–264.
- [24] Peter X. Gao, Akshay Narayan, Sagar Karandikar, Joao Carreira, Sangjin Han, Rachit Agarwal, Sylvia Ratnasamy, and Scott Shenker. 2016. Network Requirements for Resource Disaggregation. In *Proceedings of the 12th USENIX Conference on Operating Systems Design and Implementation (Savannah, GA, USA) (OSDI'16)*. USENIX Association, USA, 249–264.
- [25] Yixiao Gao, Qiang Li, Lingbo Tang, Yongqing Xi, Pengcheng Zhang, Wenwen Peng, Bo Li, Yaohui Wu, Shaozong Liu, Lei Yan, Fei Feng, Yan Zhuang, Fan Liu, Pan Liu, Xingkui Liu, Zhongjie Wu, Junping Wu, Zheng Cao, Chen Tian, Jinbo Wu, Jiayi Zhu, Haiyong Wang, Dennis Cai, and Jiasheng Wu. 2021. When Cloud Storage Meets RDMA. In *18th USENIX Symposium on Networked Systems Design and Implementation (NSDI 21)*. USENIX Association, 519–533. <https://www.usenix.org/conference/nsdi21/presentation/gao>
- [26] Joseph E. Gonzalez, Yucheng Low, Haijie Gu, Danny Bickson, and Carlos Guestrin. 2012. PowerGraph: Distributed Graph-Parallel Computation on Natural Graphs. In *Proceedings of the 10th USENIX Conference on Operating Systems Design and Implementation (Hollywood, CA, USA) (OSDI'12)*. USENIX Association, USA, 17–30.
- [27] Goetz Graefe. 2010. A Survey of B-Tree Locking Techniques. *ACM Trans. Database Syst.* 35, 3, Article 16 (July 2010), 26 pages. <https://doi.org/10.1145/1806907.1806908>
- [28] Chuanxiong Guo, Haitao Wu, Zhong Deng, Gaurav Soni, Jianxi Ye, Jitu Padhye, and Marina Lipshteyn. 2016. RDMA over Commodity Ethernet at Scale. In *Proceedings of the 2016 ACM SIGCOMM Conference (Florianopolis, Brazil) (SIGCOMM '16)*. Association for Computing Machinery, New York, NY, USA, 202–215. <https://doi.org/10.1145/2934872.2934908>
- [29] Jing Guo, Zihao Chang, Sa Wang, Haiyang Ding, Yihui Feng, Liang Mao, and Yungang Bao. 2019. Who Limits the Resource Efficiency of My Datacenter: An Analysis of Alibaba Datacenter Traces. In *Proceedings of the International Symposium on Quality of Service (Phoenix, Arizona) (IWQoS '19)*. Association for Computing Machinery, New York, NY, USA, Article 39, 10 pages. <https://doi.org/10.1145/3326285.3329074>
- [30] Zhiyuan Guo, Yizhou Shan, Xuhao Luo, Yutong Huang, and Yiying Zhang. 2022. Clio: A Hardware-Software Co-Designed Disaggregated Memory System. In *Proceedings of the Twenty-Seventh International Conference on Architectural Support for Programming Languages and Operating Systems (ASPLOS'22)*.
- [31] Qi Huang, Helga Gudmundsdottir, Ymir Vigfusson, Daniel A. Freedman, Ken Birman, and Robbert van Renesse. 2014. Characterizing Load Imbalance in Real-World Networked Caches. In *Proceedings of the 13th ACM Workshop on Hot Topics in Networks (Los Angeles, CA, USA) (HotNets-XIII)*. Association for Computing Machinery, New York, NY, USA, 1–7. <https://doi.org/10.1145/2670518.2673882>
- [32] Tianyang Jiang, Guangyan Zhang, Zhiyue Li, and Weimin Zheng. 2022. Aurora: Taming Aborts in All Phases for Distributed In-Memory Transactions. In *20th USENIX Conference on File and Storage Technologies (FAST 22)*. USENIX Association.
- [33] Anuj Kalia, David Andersen, and Michael Kaminsky. 2020. Challenges and Solutions for Fast Remote Persistent Memory Access. In *Proceedings of the 11th ACM Symposium on Cloud Computing (Virtual Event, USA) (SoCC '20)*. Association for Computing Machinery, New York, NY, USA, 105–119. <https://doi.org/10.1145/3419111.3421294>
- [34] Anuj Kalia, Michael Kaminsky, and David G. Andersen. 2016. Design Guidelines for High Performance RDMA Systems. In *Proceedings of the 2016 USENIX Conference on Usenix Annual Technical Conference (Denver, CO, USA) (USENIX ATC '16)*. USENIX Association, USA, 437–450.
- [35] Anuj Kalia, Michael Kaminsky, and David G. Andersen. 2016. FaSST: Fast, Scalable and Simple Distributed Transactions with Two-Sided (RDMA) Datagram RPCs. In *Proceedings of the 12th USENIX Conference on Operating Systems Design and Implementation (OSDI'16)*. USENIX Association, USA, 185–201.

- [36] Kimberly Keeton. 2015. The machine: An architecture for memory-centric computing. In *Workshop on Runtime and Operating Systems for Supercomputers (ROSS)*, Vol. 10.
- [37] Jongyul Kim, Insu Jang, Waleed Reda, Jaeseong Im, Marco Canini, Dejan Kostić, Youngjin Kwon, Simon Peter, and Emmett Witchel. 2021. LineFS: Efficient SmartNIC Offload of a Distributed File System with Pipeline Parallelism. In *Proceedings of the ACM SIGOPS 28th Symposium on Operating Systems Principles (Virtual Event, Germany) (SOSP '21)*. Association for Computing Machinery, New York, NY, USA, 756–771. <https://doi.org/10.1145/3477132.3483565>
- [38] Dario Korolija, Dimitrios Koutsoukos, Kimberly Keeton, Konstantin Taranov, Dejan Milošević, and Gustavo Alonso. 2021. Farview: Disaggregated Memory with Operator Off-loading for Database Engines. arXiv:2106.07102 [cs.DB]
- [39] Seung-seob Lee, Yanpeng Yu, Yupeng Tang, Anurag Khandelwal, Lin Zhong, and Abhishek Bhattacharjee. 2021. MIND: In-Network Memory Management for Disaggregated Data Centers. In *Proceedings of the ACM SIGOPS 28th Symposium on Operating Systems Principles (Virtual Event, Germany) (SOSP '21)*. Association for Computing Machinery, New York, NY, USA, 488–504. <https://doi.org/10.1145/3477132.3483561>
- [40] Philip L. Lehman and s. Bing Yao. 1981. Efficient Locking for Concurrent Operations on B-Trees. *ACM Trans. Database Syst.* 6, 4 (Dec. 1981), 650–670. <https://doi.org/10.1145/319628.319663>
- [41] Mu Li, David G. Andersen, Jun Woo Park, Alexander J. Smola, Amr Ahmed, Vanja Josifovski, James Long, Eugene J. Shekita, and Bor-Yiing Su. 2014. Scaling Distributed Machine Learning with the Parameter Server. In *Proceedings of the 11th USENIX Conference on Operating Systems Design and Implementation (Broomfield, CO) (OSDI'14)*. USENIX Association, USA, 583–598.
- [42] Kevin Lim, Jichuan Chang, Trevor Mudge, Parthasarathy Ranganathan, Steven K. Reinhardt, and Thomas F. Wenisch. 2009. Disaggregated Memory for Expansion and Sharing in Blade Servers. In *Proceedings of the 36th Annual International Symposium on Computer Architecture (Austin, TX, USA) (ISCA '09)*. Association for Computing Machinery, New York, NY, USA, 267–278. <https://doi.org/10.1145/1555754.1555789>
- [43] Ming Liu, Tianyi Cui, Henry Schuh, Arvind Krishnamurthy, Simon Peter, and Karan Gupta. 2019. Offloading Distributed Applications onto SmartNICs Using IPipe. In *Proceedings of the ACM Special Interest Group on Data Communication (Beijing, China) (SIGCOMM '19)*. Association for Computing Machinery, New York, NY, USA, 318–333. <https://doi.org/10.1145/3341302.3342079>
- [44] Yandong Mao, Eddie Kohler, and Robert Tappan Morris. 2012. Cache Craftiness for Fast Multicore Key-Value Storage. In *Proceedings of the 7th ACM European Conference on Computer Systems (Bern, Switzerland) (EuroSys '12)*. Association for Computing Machinery, New York, NY, USA, 183–196. <https://doi.org/10.1145/2168836.2168855>
- [45] Hasan Al Maruf, Yuhong Zhong, Hongyi Wang, Mosharaf Chowdhury, Asaf Cidon, and Carl Waldspurger. 2021. Memtrade: A Disaggregated-Memory Marketplace for Public Clouds. arXiv:2108.06893 [cs.DC]
- [46] Christopher Mitchell, Yifeng Geng, and Jinyang Li. 2013. Using One-Sided RDMA Reads to Build a Fast, CPU-Efficient Key-Value Store. In *Proceedings of the 2013 USENIX Conference on Annual Technical Conference (San Jose, CA) (USENIX ATC'13)*. USENIX Association, USA, 103–114.
- [47] Christopher Mitchell, Kate Montgomery, Lamont Nelson, Siddhartha Sen, and Jinyang Li. 2016. Balancing CPU and Network in the Cell Distributed B-Tree Store. In *Proceedings of the 2016 USENIX Conference on Usenix Annual Technical Conference (Denver, CO, USA) (USENIX ATC '16)*. USENIX Association, USA, 451–464.
- [48] Michael Mitzenmacher. 2001. The Power of Two Choices in Randomized Load Balancing. *IEEE Trans. Parallel Distrib. Syst.* 12, 10 (Oct. 2001), 1094–1104. <https://doi.org/10.1109/71.963420>
- [49] Christian Pinto, Dimitris Syrivelis, Michele Gazzetti, Panos Koutsovasilis, Andrea Reale, Kostas Katrinis, and H. Peter Hofstee. 2020. ThymesisFlow: A Software-Defined, HW/SW co-Designed Interconnect Stack for Rack-Scale Memory Disaggregation. In *2020 53rd Annual IEEE/ACM International Symposium on Microarchitecture (MICRO)*. 868–880. <https://doi.org/10.1109/MICRO50266.2020.00075>
- [50] Boris Pismenny, Liran Liss, Adam Morrison, and Dan Tsafir. 2022. The Benefits of General-Purpose On-NIC Memory. In *Proceedings of the Twenty-Seventh International Conference on Architectural Support for Programming Languages and Operating Systems (ASPLoS'22)*.
- [51] Pramod Subba Rao and George Porter. 2016. Is Memory Disaggregation Feasible? A Case Study with Spark SQL. In *Proceedings of the 2016 Symposium on Architectures for Networking and Communications Systems (Santa Clara, California, USA) (ANCS '16)*. Association for Computing Machinery, New York, NY, USA, 75–80. <https://doi.org/10.1145/2881025.2881030>
- [52] Yehoshua Sagiv. 1985. Concurrent Operations on B-Trees with Overtaking. In *Proceedings of the Fourth ACM SIGACT-SIGMOD Symposium on Principles of Database Systems (Portland, Oregon, USA) (PODS '85)*. Association for Computing Machinery, New York, NY, USA, 28–37. <https://doi.org/10.1145/325405.325409>
- [53] Henry N. Schuh, Weihao Liang, Ming Liu, Jacob Nelson, and Arvind Krishnamurthy. 2021. Xenic: SmartNIC-Accelerated Distributed Transactions. In *Proceedings of the ACM SIGOPS 28th Symposium on Operating Systems Principles (Virtual Event, Germany) (SOSP '21)*. Association for Computing Machinery, New York, NY, USA, 740–755. <https://doi.org/10.1145/3477132.3483555>
- [54] Alex Shamis, Matthew Renzelmann, Stanko Novakovic, Georgios Chatzopoulos, Aleksandar Dragojević, Dushyanth Narayanan, and Miguel Castro. 2019. Fast General Distributed Transactions with Opacity. In *Proceedings of the 2019 International Conference on Management of Data (Amsterdam, Netherlands) (SIGMOD '19)*. Association for Computing Machinery, New York, NY, USA, 433–448. <https://doi.org/10.1145/3299869.3300069>
- [55] Yizhou Shan, Yutong Huang, Yilun Chen, and Yiyang Zhang. 2018. LegoOS: A Diseminated, Distributed OS for Hardware Resource Disaggregation. In *Proceedings of the 13th USENIX Conference on Operating Systems Design and Implementation (Carlsbad, CA, USA) (OSDI'18)*. USENIX Association, USA, 69–87.
- [56] Yizhou Shan, Will Lin, Ryan Kosta, Arvind Krishnamurthy, and Yiyang Zhang. 2021. Disaggregating and Consolidating Network Functionalities with SuperNIC. arXiv:2109.07744 [cs.DC]
- [57] Yizhou Shan, Shin-Yeh Tsai, and Yiyang Zhang. 2017. Distributed Shared Persistent Memory. In *Proceedings of the 2017 Symposium on Cloud Computing (Santa Clara, California) (SoCC '17)*. Association for Computing Machinery, New York, NY, USA, 323–337. <https://doi.org/10.1145/3127479.3128610>
- [58] Jiwu Shu, Youmin Chen, Qing Wang, Bohong Zhu, Junru Li, and Youyou Lu. 2020. TH-DPMS: Design and Implementation of an RDMA-Enabled Distributed Persistent Memory Storage System. *ACM Trans. Storage* 16, 4, Article 24 (Oct. 2020), 31 pages. <https://doi.org/10.1145/3412852>
- [59] David Sidler, Zeke Wang, Monica Chiosa, Amit Kulkarni, and Gustavo Alonso. 2020. StRoM: Smart Remote Memory. In *Proceedings of the Fifteenth European Conference on Computer Systems (Heraklion, Greece) (EuroSys '20)*. Association for Computing Machinery, New York, NY, USA, Article 29, 16 pages. <https://doi.org/10.1145/3342195.3387519>
- [60] Lasse Thostrup, Jan Skrzypczak, Matthias Jasný, Tobias Ziegler, and Carsten Binnig. 2021. DFI: The Data Flow Interface for High-Speed Networks. In *SIGMOD'21*. accepted for publication.
- [61] Muhammad Tirmazi, Adam Barker, Nan Deng, Md E. Haque, Zhijing Gene Qin, Steven Hand, Mor Harchol-Balter, and John Wilkes. 2020. Borg: the next generation. In *EuroSys '20: Fifteenth EuroSys Conference 2020, Heraklion, Greece, April 27-30, 2020*, Angelos Bilas, Kostas Magoutis, Evangelos P. Markatos, Dejan Kostic, and Margo I. Seltzer (Eds.). ACM, 30:1–30:14. <https://doi.org/10.1145/3342195.3387517>
- [62] Shin-Yeh Tsai, Yizhou Shan, and Yiyang Zhang. 2020. Disaggregating Persistent Memory and Controlling Them Remotely: An Exploration of Passive Disaggregated Key-Value Stores. In *2020 USENIX Annual Technical Conference (USENIX ATC 20)*. USENIX Association, 33–48. <https://www.usenix.org/conference/atc20/presentation/tsai>
- [63] Stephen Tu, Wenting Zheng, Eddie Kohler, Barbara Liskov, and Samuel Madden. 2013. Speedy Transactions in Multicore In-Memory Databases. In *Proceedings of the Twenty-Fourth ACM Symposium on Operating Systems Principles (Farmington, Pennsylvania) (SOSP '13)*. Association for Computing Machinery, New York, NY, USA, 18–32. <https://doi.org/10.1145/2517349.2522713>
- [64] Midhul Vuppapalapati, Justin Miron, Rachit Agarwal, Dan Truong, Ashish Motivala, and Thierry Cruanes. 2020. Building An Elastic Query Engine on Disaggregated Storage. In *17th USENIX Symposium on Networked Systems Design and Implementation (NSDI 20)*. USENIX Association, Santa Clara, CA, 449–462. <https://www.usenix.org/conference/nsdi20/presentation/vuppapalapati>
- [65] Chenxi Wang, Haoran Ma, Shi Liu, Yuanqi Li, Zhenyuan Ruan, Khanh Nguyen, Michael D. Bond, Ravi Netravali, Miryung Kim, and Guoqing Harry Xu. 2020. Semeru: A Memory-Disaggregated Managed Runtime. In *14th USENIX Symposium on Operating Systems Design and Implementation (OSDI 20)*. USENIX Association, 261–280. <https://www.usenix.org/conference/osdi20/presentation/wang>
- [66] Qing Wang, Youyou Lu, Erci Xu, Junru Li, Youmin Chen, and Jiwu Shu. 2021. Concordia: Distributed Shared Memory with In-Network Cache Coherence. In *19th USENIX Conference on File and Storage Technologies (FAST 21)*. USENIX Association, 277–292. <https://www.usenix.org/conference/fast21/presentation/wang>
- [67] Xingda Wei, Rong Chen, and Haibo Chen. 2020. Fast RDMA-based Ordered Key-Value Store using Remote Learned Cache. In *14th USENIX Symposium on Operating Systems Design and Implementation (OSDI 20)*. USENIX Association, 117–135. <https://www.usenix.org/conference/osdi20/presentation/wei>
- [68] Xingda Wei, Zhiyuan Dong, Rong Chen, and Haibo Chen. 2018. Deconstructing RDMA-Enabled Distributed Transactions: Hybrid is Better. In *Proceedings of the 13th USENIX Conference on Operating Systems Design and Implementation (Carlsbad, CA, USA) (OSDI'18)*. USENIX Association, USA, 233–251.
- [69] Xingda Wei, Jiaxin Shi, Yanzhe Chen, Rong Chen, and Haibo Chen. 2015. Fast In-Memory Transaction Processing Using RDMA and HTM. In *Proceedings of the 25th Symposium on Operating Systems Principles (Monterey, California) (SOSP '15)*. Association for Computing Machinery, New York, NY, USA, 87–104. <https://doi.org/10.1145/2815400.2815419>
- [70] Jun Yang, Qingsong Wei, Cheng Chen, Chundong Wang, Khai Leong Yong, and Bingsheng He. 2015. NV-Tree: Reducing Consistency Cost for NVM-Based Single Level Systems. In *Proceedings of the 13th USENIX Conference on File and Storage Technologies (Santa Clara, CA) (FAST'15)*. USENIX Association, USA, 167–181.

- [71] Wonsup Yoon, Jinyoung Oh, Jisu Ok, Sue Moon, and Youngjin Kwon. 2021. DiLOS: adding performance to paging-based memory disaggregation. In *Proceedings of the 12th ACM SIGOPS Asia-Pacific Workshop on Systems*. Association for Computing Machinery, New York, NY, USA, 70–78. <https://doi.org/10.1145/3476886.3477507>
- [72] Xiangyao Yu, George Bezerra, Andrew Pavlo, Srinivas Devadas, and Michael Stonebraker. 2014. Staring into the Abyss: An Evaluation of Concurrency Control with One Thousand Cores. *Proc. VLDB Endow.* 8, 3 (Nov. 2014), 209–220.
- [73] Zhuolong Yu, Yiwen Zhang, Vladimir Braverman, Mosharaf Chowdhury, and Xin Jin. 2020. NetLock: Fast, Centralized Lock Management Using Programmable Switches. In *Proceedings of the Annual Conference of the ACM Special Interest Group on Data Communication on the Applications, Technologies, Architectures, and Protocols for Computer Communication (Virtual Event, USA) (SIGCOMM '20)*. Association for Computing Machinery, New York, NY, USA, 126–138. <https://doi.org/10.1145/3387514.3405857>
- [74] Matei Zaharia, Mosharaf Chowdhury, Michael J. Franklin, Scott Shenker, and Ion Stoica. 2010. Spark: Cluster Computing with Working Sets. In *2nd USENIX Workshop on Hot Topics in Cloud Computing, HotCloud'10, Boston, MA, USA, June 22, 2010*, Erich M. Nahum and Dongyan Xu (Eds.). USENIX Association. <https://www.usenix.org/conference/hotcloud-10/spark-cluster-computing-working-sets>
- [75] Erfan Zamanian, Carsten Binnig, Tim Harris, and Tim Kraska. 2017. The End of a Myth: Distributed Transactions Can Scale. *Proc. VLDB Endow.* 10, 6 (Feb. 2017), 685–696. <https://doi.org/10.14778/3055330.3055335>
- [76] Erfan Zamanian, Julian Shun, Carsten Binnig, and Tim Kraska. 2020. Chiller: Contention-centric Transaction Execution and Data Partitioning for Modern Networks. In *Proceedings of the 2020 International Conference on Management of Data, SIGMOD Conference 2020, online conference [Portland, OR, USA], June 14–19, 2020 (SIGMOD '20)*, David Maier, Rachel Pottinger, AnHai Doan, Wang-Chiew Tan, Abdussalam Alawini, and Hung Q. Ngo (Eds.). ACM, 511–526. <https://doi.org/10.1145/3318464.3389724>
- [77] Erfan Zamanian, Xiangyao Yu, Michael Stonebraker, and Tim Kraska. 2019. Rethinking Database High Availability with RDMA Networks. *Proc. VLDB Endow.* 12, 11 (2019), 1637–1650. <https://doi.org/10.14778/3342263.3342639>
- [78] Ming Zhang, Yu Hua, Pengfei Zuo, and Lurong Liu. 2022. FORD: Fast One-sided RDMA-based Distributed Transactions for Disaggregated Persistent Memory. In *20th USENIX Conference on File and Storage Technologies (FAST 22)*. USENIX Association.
- [79] Qizhen Zhang, Yifan Cai, Xinyi Chen, Sebastian Angel, Ang Chen, Vincent Liu, and Boon Thau Loo. 2020. Understanding the Effect of Data Center Resource Disaggregation on Production DBMSs. *Proc. VLDB Endow.* 13, 9 (2020), 1568–1581. <https://doi.org/10.14778/3397230.3397249>
- [80] Yingqian Zhang, Chaoyi Ruan, Cheng Li, Jimmy Yang, Wei Cao, Feifei Li, Bo Wang, Jing Fang, Yuhui Wang, Jingze Huo, and Chaoguo Bi. 2021. Towards Cost-Effective and Elastic Cloud Database Deployment via Memory Disaggregation. *Proc. VLDB Endow.* 14 (2021), 1900–1912.
- [81] Tobias Ziegler, Sumukha Tumkur Vani, Carsten Binnig, Rodrigo Fonseca, and Tim Kraska. 2019. Designing Distributed Tree-Based Index Structures for Fast RDMA-Capable Networks. In *Proceedings of the 2019 International Conference on Management of Data (Amsterdam, Netherlands) (SIGMOD '19)*. Association for Computing Machinery, New York, NY, USA, 741–758. <https://doi.org/10.1145/3299869.3300081>
- [82] Pengfei Zuo, Jiazhao Sun, Liu Yang, Shuangwu Zhang, and Yu Hua. 2021. One-sided RDMA-Conscious Extendible Hashing for Disaggregated Memory. In *2021 USENIX Annual Technical Conference (USENIX ATC 21)*. USENIX Association, 15–29. <https://www.usenix.org/conference/atc21/presentation/zuo>