

HEX ME IF YOU CAN

Pierre-Alexandre Beaufort¹, Maxence Reberol², Heng Liu¹, Franck Ledoux^{3,4}, David Bommes¹

¹University of Bern, CGG, 3012 Bern, Switzerland

²Université catholique de Louvain, iMMC, 1348 Louvain-la-Neuve, Belgium

³CEA, DAM, DIF, F-91297, Arpajon, France

⁴Université Paris-Saclay, CEA, LIHPC, 91680 Bruyères-le-Châtel, France

ABSTRACT

HEXME consists of tetrahedral meshes with tagged features, and of a workflow to generate them. The main purpose of HEXME meshes is to enable consistent and fair evaluation of hexahedral meshing algorithms and related techniques. The tetrahedral meshes have been generated with Gmsh, starting from 63 computer-aided design (CAD) models coming from various databases. To highlight and label the various and challenging aspects of hexahedral mesh generation, the CAD models are classified into three categories: simple, nasty and industrial. For each CAD model, we provide three kinds of tetrahedral meshes. The mesh generation yielding those 189 tetrahedral meshes is defined thanks to Snakemake, a modern workflow management system, which allows us to define a fully automated, extensible and sustainable workflow. It is possible to download the whole dataset or to pick some meshes by browsing the online catalog. Since there is no doubt that the hexahedral meshing techniques are going to progress, the HEXME dataset is also built with evolution in mind. A public GitHub repository hosts the HEXME workflow, in which external contributions and future releases are possible and encouraged.

Keywords: tetrahedral dataset, feature entities, transparent workflow, hexahedral mesh generation

1. INTRODUCTION

Structured hexahedral meshes are highly desired to perform fast, accurate and adaptive numerical simulations. For an even number of vertices, there are at least five times less hexahedra than tetrahedra[1]. Hexahedral finite elements offer a richer functional space, and if they are structured, they may provide discrete schemes whose effectiveness is close to finite difference methods. The regularity¹ of the local topology allows to perform anisotropic refinements where finer approximations are needed.

Those last decades, the mesh community has been actively working on developing auxiliary tools, in order to implement a robust and automatic hexahedral mesher, Fig.1. Although numerous researches and works have been done, this numerical dream remains

an unsolved challenge up to this day. Indeed, there is no *automatic* method yielding *robustly* a high *quality* hexahedral mesh. Industrial methods manage to provide high quality meshes, but they typically involve tedious and lengthy user interventions. Automatic methods such as advanced frontal[2] and polycube-based[3] approaches are not guaranteed to be robust, neither to build high quality hexahedra. Solely octree-based procedures[4] can automatically and robustly supply a full hexahedral mesh, but with a quality far from ideal on the boundary. Three-dimensional octahedral frame-based methods are able to automatically and robustly make a high quality mesh, *provided* that the octahedral singularities (i.e. not a frame) consistently match irregular configurations (eg. an edge shared by 5 hexahedra)[5] of hexahedral grids.

Most of the algorithms tackling the hex meshing challenge use tetrahedral meshes in the background. Yet, there misses a tetrahedral dataset to perform objective

¹almost everywhere

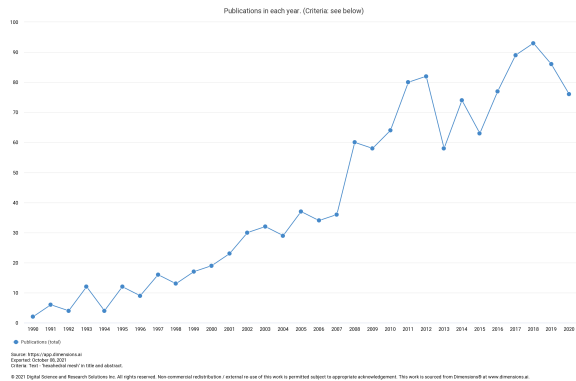

Figure 1: Yearly number of publications related to hexahedral meshes. Source: app.dimension.ai.

analyses and fair comparisons of state-of-the-art hexahedral methods. Moreover, enabling such a dataset would allow identifying common issues, hence providing awareness of improvement clues.

Here is HEXME dataset, a collection of tetrahedral meshes with tagged feature entities. The feature entities are special points, curves and/or surfaces, which should be factually captured by a hexahedral mesh. All meshes have been generated from computer-aided design (CAD) models, following a workflow defined with Snakemake[6], using Gmsh[7] API with custom parameters defined in yaml metadata files. CAD models are classified in three categories (simple, nasty, industrial), in order to grade their difficulty and consistency. For each model, three meshes are provided: two resolutions (coarse, uniform) to analyze the mesh dependency, and a playground (bounding) to dare customizable methods. The meshes are exported as vtk datafiles (version 2, ascii mode), a mesh format which is broadly used.

This paper first describes datasets whose content is comparable with HEXME. Afterwards, the pipeline having produced the tetrahedral meshes from CAD models is fully exposed. HEXME dataset is then dedicated to present what is available *as-is*. Finally, some hexahedral methods are applied to the dataset, in order to give some insight about HEXME purpose.

2. COMPARABLE DATASETS

Tetwild Even though Tetwild[8] is a tetrahedral meshing technique, it is also a tetrahedral dataset, since the authors provide the output of their algorithm applied to Thingi10k[9], a triangular dataset. This tetrahedral dataset is the tetrahedrization of ten thousand models from Thingi10k. The tetrahedral meshes are `msh2` binary files, with a scalar field per tetrahedron corresponding to their respective minimal dihedral

angle. The 10k meshes are stored on Google drive, within an archive `tar.gz`.

ABC The ABC[10] dataset is a collection of one million computer-aided design models for geometric deep learning. All CAD files are from Onshape, and the original information related to those models is recorded within a metadata file `meta.yaml`. Some processing tasks are done in order to filter the duplicate and broken models. The filtered models `para.zip` are afterwards converted into `step.step` and `stl.stl` files, using Parasolid. Gmsh[7] is then used to provide higher quality triangular meshes (either uniform, or adapted to the curvature), which are exported as `obj.obj` meshes, from the `.step` files. Differential quantities are stored in those `obj` files, while the vertices and triangles of the mesh are respectively matched to the feature curves and patches, through another metadata file `feat.yaml`. Further files may be provided, depending on the success of the processing. The dataset is downloadable by chunks containing 7z archives of above files.

Thingi10k Historically, Thingi10k[9] is the first dataset providing ten thousand various, complex and quality `.stl` triangulations of 3D (printing) models. All models come from Thingiverse, and have been selected only if they are tagged *featured* by the Thingiverse staff. An online query interface is provided, which returns all the contextual and original information related to a stl triangulation. This interface is the only way to access to the dataset.

SimJEB A recent² dataset, SimJEB[11], provides 381 tetrahedral meshes from CAD models, by following a *semi-automated* pipeline. The CAD models come from a challenge organized by GrabCAD. Those former 700 models have been filtered (mostly based on the filename), manually repaired, and then meshed using the commercial software HyperMesh. Eventually, a structural simulation was performed using the commercial software OptiStruct. The 381 `.vtk` tetrahedral meshes surviving this pipeline are hosted through the Harvard Dataverse, along with the corresponding clean CAD `.stp` file, triangular surface `.obj` meshes, finite element `.fem` models, and simulation `.csv` results. The final models are identified by an integer, whose origin is tracked by some `readme` files. A web page allows to browse the designs, and to explore the data.

²2021

3. FROM CAD TO TETS

All the tetrahedral meshes provided by HEXME have been produced from three categories of CAD models:

- **simple models**: basic shapes that are assumed to be easily hex-meshable, i.e. the target hexahedral topology is fair (eg. a cube, Fig.2a).
- **nasty models**: academic shapes that are challenging to hex-mesh (eg. a pyramid[12], Fig.2b).
- **industrial models**: lifelike shapes whose hexahedrization is highly valuable for numerical simulation (eg. an aircraft model for CFD, Fig.2c).

The 63 CAD models have been arbitrarily selected. Nevertheless, we believe that those models already represent most of the situations/challenges that hexahedral meshers face at the moment. Besides, their number is low enough to allow human assessment of hexahedral methods from this dataset.

Instead of the comparable datasets (§2), the CAD models come from several databases: ABC dataset (originally from Onshape), GrabCAD and MAMBO. Some CAD models have been created by us, using Gmsh and Siemens NX softwares. Those latter models are in the *public domain*, while the other ones are regulated by licenses, which are respectively: Onshape Terms 1(g)(i), GrabCAD Terms (cf. related FAQ) and Apache 2.0. The above information is reported within a metadata file `(s|n|i)\(d{2})o_{extra}.yaml` per CAD model, with a short description of the shape (eg.listing 1).

Listing 1: `i28o_gc_tire_1218.yaml`

```
author: Milos Suvakov, https://grabcad.com/milos.suvakov
description: tire of a truck
license: GrabCAD Terms
name: i28o_gc_tire_1218
original: original/i28o_gc_tire_1218.step
references: https://grabcad.com/library/tire-12-00-18-1
```

For every CAD model, three tetrahedral meshes are provided:

- **coarse mesh**: the mesh size is only upper bounded s.t. the geometry is maintained (eg. Fig.3a).
- **uniform mesh**: the mesh size is constant, even in the neighborhood of the tiniest geometrical features (eg. Fig.3b).
- **bounding mesh**: the initial model is immersed in a box that is as twice as large as the original bounding box, and the corresponding mesh is such that the smallest gap between the box side and the initial model is meshed by one layer of tetrahedra (eg. Fig.3c).

The pipeline handling the mesh generation is orchestrated by Snakemake[6], a popular³ scalable workflow management system. In few words, Snake-`make` is a modern version of `Makefile`, whose syntax is close to Python. The workflow `Snakemesh` consists of two rules. On one hand, the first rule `meshes` defines which meshes should be produced. On the other hand, the second rule `cad2vtk` generates a mesh from CAD model and a metadata file `(s|n|i)\(d{2})o_{extra}.yaml` containing the custom mesh options (among those: either `coarse`, `uniform` or `bounding`). To do so, this second rule runs a python script using Gmsh api, with a maximum of 8 threads. For each mesh, a log file `(s|n|i)\(d{2})o_{extra}.txt` is written with the corresponding console output, in order to record the history of the meshing task.

Snakemake scans the workflow in a backward fashion, meaning that the input files are identified from the output ones. In other words, the purpose of the first rule is to state all meshes that should be produced. Afterwards, the second rule provides those meshes by identifying accordingly the corresponding input files, which are the CAD model and metadata file. This backward identification is the key of the workflow definition, since the rules are mostly written with wildcards. The use of Snakemake easily yields a sustainable dataset, since a rule is applied only if an output is older than the corresponding input or missing.

Gmsh[7] does not mesh only the volume, but also the feature entities as defined by the CAD model. In addition to the tetrahedral cells, there are triangular, edge and vertex cells⁴ to respectively discretize feature surfaces, curves and points. Those features are identified by the CAD with a color (i.e. a positive integer), which corresponds to a physical group within Gmsh. Doing so, the analogous mesh cells are created accordingly with the corresponding CAD color. Meshes are exported as vtk Datafile Version 2.0, in ASCII mode. The used Gmsh git-version is written within the file header. A mesh is defined as an `UNSTRUCTURED_GRID`, with the four following sections:

1. `POINTS`: coordinates of every node
2. `CELLS`: number of nodes, and nodal definition of every element (vertices, edges, triangles and tetrahedra)
3. `CELL_TYPES`: integer corresponding to the element type (`{1:vertex, 3:edge, 5:triangle, 10:tetrahedron}`)

³~ 5 citations per week

⁴those lower dimensional cells are conforming to the higher ones

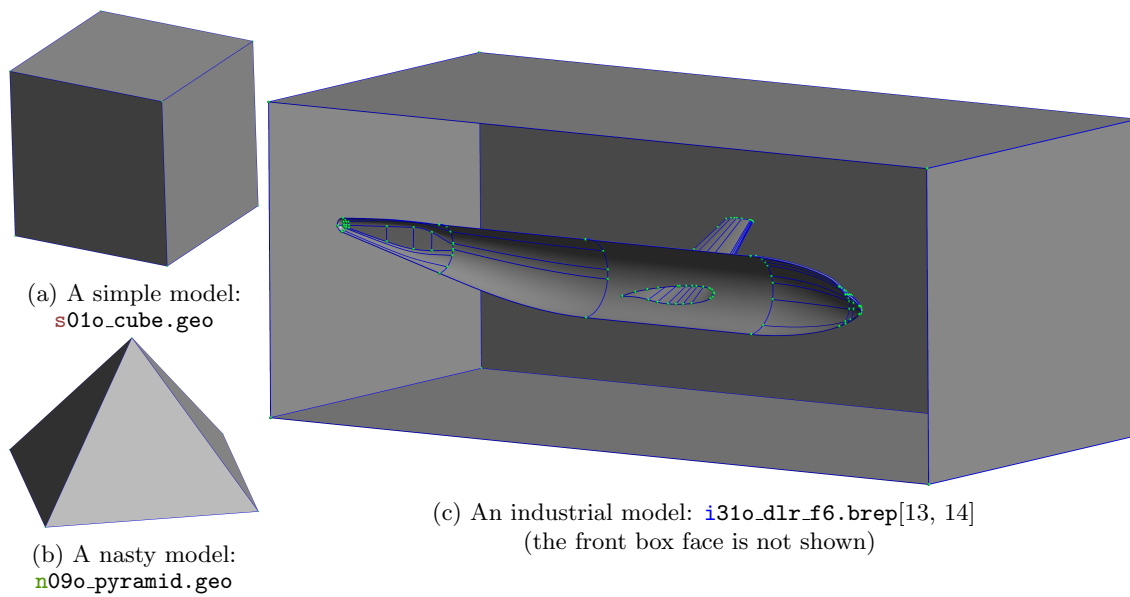

Figure 2: HEXME uses three categories of CAD models.

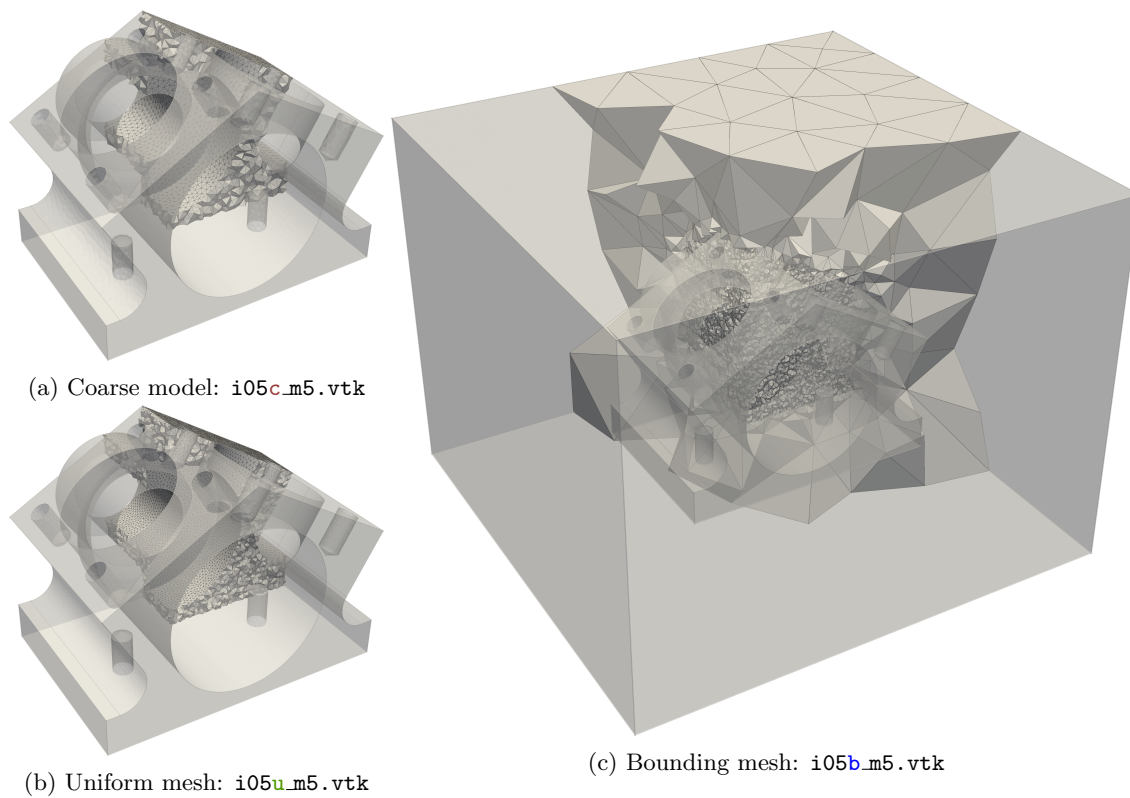

Figure 3: There are three tetrahedral meshes per CAD model, eg. `i05o_m5.step` from MAMBO.

- CELL_DATA: integer corresponding to the element color that belong to the CAD feature.

```
# vtk DataFile Version 2.0
, Created by Gmsh 4.9.0-git-b39c72341
ASCII
DATASET UNSTRUCTURED_GRID
POINTS 9332 double
47.96187233897071 17.79329564613556 3.334023045560881e-14
[...]
CELLS 51854 233863
1 0
[...]
CELL_TYPES 51854
1
[...]
CELL_DATA 51854
SCALARS CellEntryIds int 1
LOOKUP_TABLE default
1
[...]
```

There are then 189 meshes, whose the given file-names (`s|n|i`)(`\d{2}`)(`c|u|b`)-`{extra}`.`vtk` summarize the corresponding model (`s|n|i`)(`\d{2}`) and mesh (`c|u|b`) types.

4. HEXME ANATOMY

HEXME tetrahedral dataset is downloadable in a single file: `hexme.zip`(~1.5GB, stored on `cgg.unibe` server). Otherwise, it is possible to download meshes *one-by-one* from the catalog⁵ (stored on `cgg.unibe` server). The catalog is split into three categories (i, n, s), which corresponds to the model categories (respectively: `industrial`, `nasty`, `simple`), Fig.4. Within each category, there are three subcategories (b, c, u), which corresponds to the mesh types (respectively: `bounding`, `coarse`, `uniform`).

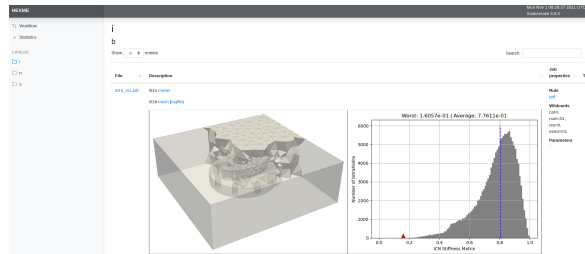

Figure 4: An entry of HEXME catalog: `i01b_m1`.

An entry of the catalog is described by two pictures (a cut view and a quality histogram), a `.pdf` file, a `.vtk` mesh, the corresponding log file (`s|n|i`)(`\d{2}`)(`c|u|b`)-`{extra}`.`txt` and the metadata file (`s|n|i`)(`\d{2}`)-`{extra}`.`yaml` related to the CAD model. The `.pdf` sheet of a mesh summarizes the mesh, Fig.5. The summary provides topological information about the CAD model (number of points, curves and surfaces), and the mesh (number of vertices, edges, triangles, tetrahedra and nodes). Moreover, two histograms related to the inverse condition number (ICN)[15, §2.1] of triangles and tetrahedra are

⁵The catalog is mostly generated by Snakemake, by using the report feature.

plotted. Finally, four screenshots (`xy`-, `yz`-, `zx`- and 3D-views) of the cut mesh are displayed.

HEXME – `i08c_m8`

	# Points	# Lines	# Surfaces
CAD Features	100	148	52

	# Vertices	# Edges	# Triangles	# Tetrahedra	# Nodes
Mesh Elements	100	3655	112942	358605	87143

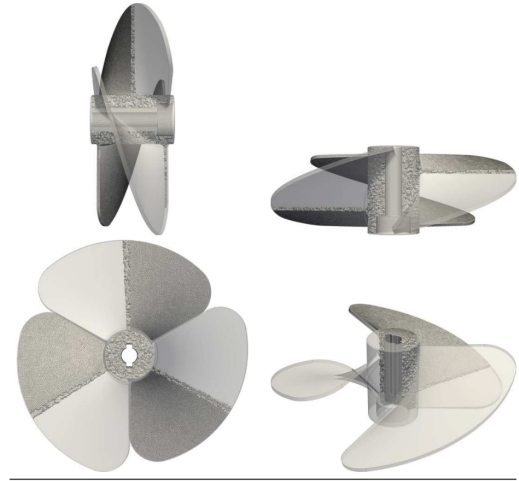
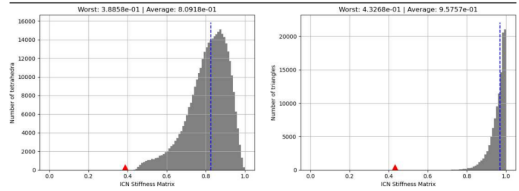

Figure 5: Sheet summarizing `i08c_m8`.

In addition to those entries, some data related to the workflow are available. The graph corresponding to the workflow is displayed, Fig.6a. This graph is longer than what have been introduced into the former section 3. Actually, the views, histograms and sheets are also generated by the workflow. It is possible to obtain details of a rule by clicking on the corresponding node, Fig.6c. The creation and duration times are also given in statistics, Fig.6b.

On top of HEXME catalog, there is a public GitHub page hosting all the necessary input files to run the workflow. The tetrahedral meshes are not hosted on this git repository⁶. The main purpose of this git repository is to expose the workflow that has been used for the mesh generation. From this repository, it is possible to create `issue` if one mesh does not meet user expectations. The mesh community is also invited to contribute to HEXME dataset, by creating `pull-request` which would consist of proposing

⁶The git history would be too heavy otherwise.



(a) The whole workflow: from CAD to pdf

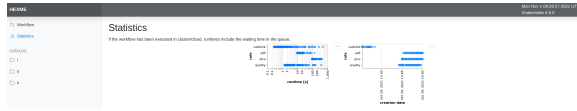

(b) Duration and timestamp

Rule pics

Jobs 189

Input files

- meshes/{id}{res}_{extra}.vtk

Output files

- figs/{id}{res}_{extra}-0.png
- figs/{id}{res}_{extra}-1.png
- figs/{id}{res}_{extra}-2.png
- figs/{id}{res}_{extra}-3.png

Code

```

1 ##### import the simple module from the paraview
2 from paraview.simple import *
3 import subprocess
4 #import sys
5
6 def myclip(theinput, thenormal, therender, toinvert=True):
7     clip = Clip(Input=theinput, Invert=toinvert)
8     clip.ClipType = "Plane"
9     clip.ClipType.Normal = thenormal
10    clip.Crinkleclip = 1
11    clipDisplay = Show(clip, therender, EdgeColor=[0,0,0])
12    clipDisplay.Representation = 'Surface With Edges'
13    clipDisplay.ColorArrayName = [None, '']
14    return clip
15 #_end of def myclip
16
17 def create_pictures_XYZ(mesh):
18     if(not mesh.endswith(".vtk")):
19         print("ERROR: input file must be a VTK legacy file (.vtk)")
20         exit(1)
21
22
23     ##### disable automatic camera reset on 'Show'
24     paraview.simple._DisableFirstRenderCameraReset()
25
26     paraview.simple.Disconnect()
27     paraview.simple.Connect()
28     # create a new 'Legacy VTK Reader'
29     data = LegacyVTKReader(FileName=[mesh])

```

(c) Details about the rule pics

Figure 6: Data about HEXME workflow.

new models or/and filtering former ones. There shall be releases, with appropriate `git-tag`, whenever the dataset has been significantly updated.

Concretely, HEXME GitHub repository contains:

- CAD models: `original/*`
- metadata files related to the CAD models: `meta/*o*.yaml`
- metadata files related to the mesh parameters: `meta/*(b|c|u)*.yaml`
- python scripts involved in the mesh generation and catalog constructions: `scripts/*.py`
- the template for an entry of the catalog: `report/description.rst`

- the Snakemake files defining the workflow: `Snakemesh`, `Snakefile` (& `utilies.smk`)
- the virtual machine used to run the mesh generation: `Dockerfile`
- the pipeline definition to publish the meshes: `.gitlab-ci` and `CI/*`
- the MIT License for the meshes, and the workflow: `LICENSE`
- a `README.md` file

The workflow supports the CAD models whose extension is one of the following: `.geo`, `.step`, `.stp`, `.brep`. For every CAD model, four metadata files have to be defined. The first one gives information about the model

```

description: ...
license: ...
name: {i|n|s}{d{2}}o_{extra}
original: original/{i|n|s}{\d{2}}o_{extra}.(geo|step|stp|brep)
references: ...

```

The three other ones define the mesh parameters for a mesh type (b|c|u)

Listing 2: Coarse mesh type

```

gmsh.option.setNumber:
- Mesh.Algorithm: ...
- Mesh.Algorithm3D: ...
- General.NumThreads: ...
- Mesh.CharacteristicLengthMax: ...
- Mesh.MeshSizeFromCurvature: ...
info: meta/{i|n|s}{\d{2}}o_{extra}.yaml

```

Listing 3: Uniform mesh type

```

gmsh.option.setNumber:
- Mesh.Algorithm: ...
- Mesh.Algorithm3D: ...
- General.NumThreads: ...
- Mesh.CharacteristicLengthMin: ...
- Mesh.CharacteristicLengthMax: ...
info: meta/{i|n|s}{\d{2}}o_{extra}.yaml

```

Listing 4: Bounding mesh type

```

gmsh.model.mesh.setSize:
- ipts: ...
gmsh.option.setNumber:
- Mesh.Algorithm: ...
- Mesh.Algorithm3D: ...
- General.NumThreads: ...
- Mesh.MeshSizeExtendFromBoundary: ...
- Mesh.MeshSizeFromPoints: ...
- Mesh.MeshSizeFromCurvature: ...
info: meta/{i|n|s}{\d{2}}o_{extra}.yaml

```

5. HEXAHEDRAL TEASER

To come up.

6. CONCLUSION

HEXME is twofold. On one hand, it is a tetrahedral dataset with feature entities. On the other hand, it is a transparent workflow. The main objective of HEXME is to provide relevant tetrahedral meshes for the fair assessment of hexahedral meshers, and associated auxiliary tools such as 3D frame fields. The consistency of available meshes will likely evolve along with the

progress of hexahedral techniques. It is then crucial to expose the pipeline defining the mesh generation, such that HEXME dataset does not become obsolete.

The selected 63 CAD models come from several databases. Their origin and license are recorded within a metadata file. There are three categories of CAD models, and three types of meshes per CAD model. The 189 meshes are produced thanks to a workflow that is defined with Snakemake. The CAD features are reproduced by Gmsh as lower dimensional elements. The meshes are expressed as vtk Datafile Version 2.0, in ASCII mode.

There are two ways to access HEXME tetrahedral meshes: either by downloading all of them in a 1.5GB .zip file, either by picking some of them from the catalog. The .zip file also contains the log files from the mesh generation. In addition to the meshes and log files, the catalog yields the metadata related to the CAD model, a summary about the mesh, and information related to the workflow. The files that are involved in the workflow, are available on a GitHub repository. From this git repository, it is possible to raise issue or/and pull-request, in order to improve the dataset, or the workflow.

In the future, the meshes should be tagged, like a release. Besides, a doi should be set with Zenodo whenever a release occurs. This identification is crucial in order to keep track of the assessment of hexahedral methods.

ACKNOWLEDGEMENTS

HEXME dataset is part of the ERC Starting Grant project "Algorithmic Hexahedral Mesh Generation" – ERC AlgoHex, which is funded by the European Research Council under the European Union's Horizon 2020 research and innovation programme (Grant agreement No. 853343).

References

- [1] Pellerin J., Verhetsel K., Remacle J.F. "There Are 174 Subdivisions of the Hexahedron into Tetrahedra." *ACM Trans. Graph.*, vol. 37, no. 6, Dec. 2018. URL <https://doi.org/10.1145/3272127.3275037>
- [2] Baudouin T.C., Remacle J.F., Marchandise E., Henrotte F., Geuzaine C. "A frontal approach to hex-dominant mesh generation." *Advanced Modeling and Simulation in Engineering Sciences*, vol. 1, no. 1, 1–30, 2014
- [3] Cherchi G., Alliez P., Scateni R., Lyon M., Bommes D. "Selective padding for polycube-based hexahedral meshing." *Computer graphics forum*, vol. 38, pp. 580–591. Wiley Online Library, 2019
- [4] Gao X., Shen H., Panozzo D. "Feature Preserving Octree-Based Hexahedral Meshing." *Computer Graphics Forum*, vol. 38, pp. 135–149. Wiley Online Library, 2019
- [5] Liu H., Zhang P., Chien E., Solomon J., Bommes D. "Singularity-constrained octahedral fields for hexahedral meshing." *ACM Trans. Graph.*, vol. 37, no. 4, 93–1, 2018
- [6] Mölder F., Jablonski K.P., Letcher B., Hall M.B., Tomkins-Tinch C.H., Sochat V., Forster J., Lee S., Twardziok S.O., Kanitz A., et al. "Sustainable data analysis with Snakemake." *F1000Research*, vol. 10, 2021
- [7] Geuzaine C., Remacle J.F. "Gmsh: A 3-D finite element mesh generator with built-in pre-and post-processing facilities." *International journal for numerical methods in engineering*, vol. 79, no. 11, 1309–1331, 2009
- [8] Hu Y., Zhou Q., Gao X., Jacobson A., Zorin D., Panozzo D. "Tetrahedral Meshing in the Wild." *ACM Trans. Graph.*, vol. 37, no. 4, 60:1–60:14, Jul. 2018. URL <http://doi.acm.org/10.1145/3197517.3201353>
- [9] Zhou Q., Jacobson A. "Thing10K: A Dataset of 10,000 3D-Printing Models." *arXiv preprint arXiv:1605.04797*, 2016
- [10] Koch S., Matveev A., Jiang Z., Williams F., Artemov A., Burnaev E., Alexa M., Zorin D., Panozzo D. "ABC: A Big CAD Model Dataset For Geometric Deep Learning." *The IEEE Conference on Computer Vision and Pattern Recognition (CVPR)*. June 2019
- [11] Whalen E., Beyene A., Mueller C. "SimJEB: Simulated Jet Engine Bracket Dataset." *Computer Graphics Forum*, 2021
- [12] Verhetsel K., Pellerin J., Remacle J.F. "A 44-element mesh of Schneiders' pyramid: Bounding the difficulty of hex-meshing problems." *Computer-Aided Design*, vol. 116, 102735, 2019. URL <https://www.sciencedirect.com/science/article/pii/S0010448519302465>
- [13] Vassberg J.C., Tinoco E.N., Mani M., Brodersen O.P., Eisfeld B., Wahls R.A., Morrison J.H., Zickuhr T., Laflin K.R., Mavriplis D.J. "Abridged summary of the third AIAA computational fluid dynamics drag prediction workshop." *Journal of Aircraft*, vol. 45, no. 3, 781–798, 2008

- [14] Brodersen O., Eisfeld B., Raddatz J., Frohnapfel P. “DLR results from the third AIAA computational fluid dynamics drag prediction workshop.” *Journal of Aircraft*, vol. 45, no. 3, 823–836, 2008

- [15] Johnen A., Geuzaine C., Toulorge T., Remacle J.F. “Efficient Computation of the Minimum of Shape Quality Measures on Curvilinear Finite Elements.” *Procedia Engineering*, vol. 163, 328–339, 2016. URL <https://www.sciencedirect.com/science/article/pii/S1877705816333768>.
25th International Meshing Roundtable