

Automatic Diversity in the Software Supply Chain

Nicolas Harrand*, Thomas Durieux*, David Broman*[†], and Benoit Baudry*

**EECS, KTH Royal Institute of Technology, Stockholm, Sweden*

Email: {harrand, tdurieux, dbro, baudry}@kth.se

[†] *Digital Futures*

Abstract—Despite its obvious benefits, the increased adoption of package managers to automate the reuse of libraries has opened the door to a new class of hazards: supply chain attacks. By injecting malicious code in one library, an attacker may compromise all instances of all applications that depend on the library. To mitigate the impact of supply chain attacks, we propose the concept of Library Substitution Framework. This novel concept leverages one key observation: when an application depends on a library, it is very likely that there exists other libraries that provide similar features. The key objective of Library Substitution Framework is to enable the developers of an application to harness this diversity of libraries in their supply chain. The framework lets them generate a population of application variants, each depending on a different alternative library that provides similar functionalities. To investigate the relevance of this concept, we develop ARGON, a proof-of-concept implementation of this framework that harnesses the diversity of JSON suppliers. We study the feasibility of library substitution and its impact on a set of 368 clients. Our empirical results show that for 195 of the 368 java applications tested, we can substitute the original JSON library used by the client by at least 15 other JSON libraries without modifying the client’s code. These results show the capacity of a Library Substitution Framework to diversify the supply chain of the client applications of the libraries it targets.

Index Terms—Software supply chain, Library Substitution, Software repository, Software reuse, Java, Maven Central Repository



1 INTRODUCTION

Modern software development increasingly relies on the reuse of external libraries. The past decades have seen the emergence of online software repositories hosting thousands, sometimes millions, of software artifacts ready for reuse [1]. Package managers that automate library resolution from these repositories have greatly facilitated the practice [2]. Increasingly, modern software consists, in a majority of external libraries glued together by a minority of business specific code directly written by the developer [3]. The benefit of relying on externally developed software artifacts is twofold: development and maintenance time is decreased, and software used by thousands of other applications may receive more scrutiny.

However, depending on third-party libraries opens up for a whole new category of hazards. Bugs [4], breakages [5], and supply chain attacks [6], [7] can now occur in all the dependencies of an application and not solely in the code controlled by the application developer. For example, in March 2016, the removal of the `left-pad` package from the NPM registry broke the build of thousands of JavaScript projects [5], [2]. More recently, thousands of SolarWinds customers have been compromised through a malicious update. This incident raised questions on how to reliably use software dependencies [8].

The breadth of supply chain attacks is a major challenge. Compromising one single library [9] affects every instance of any application depending on the library. This makes popular libraries target of choices for malicious actors. On the other hand, seminal work by Forrest [10] and Cohen [11]

have proposed to distribute software variants instead of running identical instances across a network of machine, to mitigate the scale of attacks.

We propose to diversify the libraries in the supply chain of applications to mitigate the scale of supply chain attacks. For many application domains, there exist several alternative libraries providing similar features. This opens the door to the generation of variants of an application by substituting libraries in its supply chain. Unfortunately, these libraries cannot be directly substituted. They typically do not provide the same API [12]: features might not be divided in the same way, signatures may be different, etc. Hence, replacing one by another, requires considerable effort.

In this work, we introduce the concept of Library Substitution Framework. To support the substitution of libraries that provide similar features with different APIs, without modifying the application code, we propose to separate the API from the actual implementation. Keeping the API intact is necessary to prevent changes in the application. To bind the API to an actual implementation, we propose a three-tier adaptation architecture. First, a bridge provides the same API as the original and maps this API to an abstract Facade. The Facade captures the core features that are common to the pool of similar libraries. The third-tier for adaptation relates the Facade to an actual implementation. For a specific library, a wrapper implements this relation to the Facade’s features. With this three-tier architecture we save the effort of developing one adapter per combination of possible library substitution.

To assess the feasibility of this architecture, diversifying

supply chains, we implement a concrete framework for Java JSON libraries. The framework, called ARGO, supports substituting a JSON library present in the supply chain of an application, by another JSON library. We discuss the implementation process of ARGO, its design choices, and experiment the reuse of the test suites of existing JSON libraries to validate it. We also assess the effect of library substitution on 368 clients of JSON libraries. We successfully generate 4,069 variant applications that use a completely different implementation of a JSON library than the original and still pass the same tests as the original. For all these case studies, we have checked that the tests of the applications invoke a part of the JSON API. These novel results demonstrate the opportunity of harnessing the natural diversity of library implementations in a Library Substitution Framework to diversify the supply chain of applications. Our library substitution architecture is generic and can be reused to diversify other parts of the supply chain for which there exist diverse implementations.

Our contributions are as follows

- an original architecture for a Library Substitution Framework to diversify the supply chain of an application, without changing the application’s source code;
- ARGO, a proof-of-concept implementation of this framework to provide build time diversification of JSON suppliers;
- novel empirical evidence that a Library Substitution Framework can generate application variants that have different dependencies as the original applications and still behave the same, modulo test suite.

2 RISKS OF MONOCULTURE IN THE SOFTWARE SUPPLY CHAIN

This section introduces the context of our work. We summarize the challenges of library reuse, with respect to software supply chain attacks.

2.1 Software Supply Chain Attacks

Package managers automatically fetch third-party libraries from a repository and integrate them into applications [1], [2]. There exist package managers and an associated repository for most programming languages. For instance, Java has Maven and Maven Central, JavaScript has NPM and the NPM repository, Python has pip and PyPI.

Massive dependence on external software artifacts raises new reliability and security concerns. New external actors become involved in the development of software projects: the developers of all external libraries used in the project. Furthermore, external libraries come with dependencies of their own, making the complete audit of libraries more difficult. Consequently, third-party software libraries represent an essential and complex part of the software supply chain of applications [6], [13]. This opens the door to software supply chain attacks, that specifically target third-party packages [6].

Such attacks include package typo squatting [7], trusting the trust attacks [14], and social engineering on open-source packages. An example of such an attack is demonstrated by the incident related to the `event-stream` package from

the NPM registry. A malicious actor managed to gain the trust of the owner by contributing legitimate patches to the package [9]. The owner then handed over the control of the repository to the malicious actor, who used it to inject code stealing cryptocurrency keys available on the machine of anyone running code depending on the `event-stream` package.

2.2 Diversity Reservoirs in Software Repositories

Software repositories host millions of libraries. Among these numerous libraries, many of them provide similar features. For example, *mvnrepository.com* lists more than 80 different HTTP clients libraries for the JVM, more than 40 different logging frameworks, and more than 20 Base64 libraries. These different libraries that provide similar functionalities, are developed by different developers, with different motivations and without coordination. In the remaining of this paper, we call such a group of libraries implementing similar features, a *reservoir*.

The libraries in a reservoir do not provide the exact same features, but very similar ones, typically related to a standard. For example, network libraries implement well-specified protocols (HTTP, TCP, IP), cryptography libraries implement the same algorithms (TLS, RSA, SHA1), and data manipulation libraries implement various formats (JSON, XML, YAML).

This natural diversity of library implementations for specific features has been harnessed in previous work. Koopman and DeVale studied the diversity of POSIX implementations and use it for reliability [15]. Shacham and colleagues exploit the diversity of collection libraries [16] to optimize the applications depending on them. Sondhi [17] reuses the test cases of similar libraries. Our work is the first to propose to harness diverse libraries to generate variant applications.

2.3 Library Monoculture

While there exist a diversity of library implementations, the actual usages are skewed on a small subset of them. Applications massively depend on a handful of packages, while most other packages are rarely depended upon [1]. Library usages in a software repository follow a power law [18]. Zerouali and Mens [19] found that 97% of the projects using Maven on GitHub declared a dependency towards `junit`. Meanwhile, the second most popular test library, `TestNG` is only used by 11.9% of the projects of their dataset (most of them also using `junit`). This unequal distribution of usages within a library reservoir is far from an exception. For example, *mvnrepository.com* lists 11,628 usages within Maven Central of `Apache HttpClient`, the most popular HTTP client library and only 6,604 for the second most popular one `OkHttp`. The large number of applications that rely on the same popular libraries is evidence that a new form of software monoculture [20], [21] emerges in software repositories.

The concentration of usages magnifies the risks of software supply chain attacks that target the popular libraries shared across a large number of applications. Meanwhile, there exist alternative implementations that provide the same features as these popular libraries. In this work, we

propose to harness this diversity of implementations in order to mitigate the risk of having one vulnerable library used by all applications. Today, the discrepancy among alternative APIs and the entanglement between application and library code prevent a smooth, automatic replacement of one library by another. Some previous work lay the ground for this. In the Java ecosystem, Java Specification Requests [22] are formal documents to standardize the APIs of the different libraries of a specific domain. However, the general case is that the multiple libraries which implement similar features are not inter-changeable, as they have different APIs. On the client side, there is a rich literature on API migration [23], [24] that describes how to modify clients calls to APIs to adapt them to alternative libraries. However, none of these approaches allow a fully automated migration of existing clients from a library to an alternative.

State-of-the-art techniques for API specification and migration do not support the automatic synthesis of diversified applications based on the alternative library implementations available in software repositories. In the next section, we discuss one key conceptual challenge that prevents this form of diversification in the supply chain.

2.4 Client-library Entanglement

When the developers of an application identify the need for a specific feature, they will usually find several libraries that provide the desired feature. For example, the *reservoir* for HTTP client libraries in Maven Central contains libraries such as `Apache HttpClient`, `OkHttp`, or `Jetty client`¹. Yet, to use the desired feature, a developer needs to declare, in the configuration file of its package manager, a dependency towards one specific library. For example, a developer will not declare a dependency towards an abstract HTTP client, but towards the specific library `Apache HttpClient` version 4.5.13. The package manager will then automatically fetch the library and bundle it with the rest of the application. Once the chosen library is fetched, the desired feature can be used through direct calls to the library's API. For example, in the case of `Apache HttpClient`, it may be instantiating an object from the class `CloseableHttpClient` and calling its method `execute` to execute an HTTP query.

Application developers might need an abstract feature regardless of what library implements it. Yet, to use this feature, they need to choose a *specific library* and make their code *entangled* with its API. Meanwhile, alternative libraries might propose very different APIs, with different abstractions. Methods might take a different number of parameters, or parameters of different types. This makes migrations from a library to an alternative potentially time costly [25]. Furthermore, migration requires good knowledge of the former library's API, the new library's API and the ability to modify the code of the client. This problem intensifies in the context of transitive dependencies, i.e., third-party libraries depended upon by a client's library. For example, `Apache HttpClient`, in its version 4.5.13, depends on other libraries such as `commons-codec` and `commons-logging`. This means that a project that depends

on `Apache HttpClient` also depends on these two libraries. In this case, the developer of such a project typically does not have the possibility of modifying the source code of `Apache HttpClient`, hence performing a migration from `commons-codec` to an alternative library is unpractical.

The entanglement between application code and APIs, the diversity of APIs in a reservoir and the complexity of dependency trees are key challenges that we need to address in order to automate library substitution.

3 AUTOMATIC DIVERSIFICATION IN THE SOFTWARE SUPPLY CHAIN

In this work, we aim at letting developers benefit from the natural diversity of libraries in a given domain. Our goal is to build diverse application variants, with the same functionalities, but diverse supply chains. Given an application that depends on a specific library, we propose a systematic way to substitute this library, without modifying the source code of either the application nor the library.

3.1 Generating a Population of Variants

A software supply chain attack that targets one single library has the potential to disrupt all the instances of an application that depends on the library. In this work, we propose to mitigate this risk through supply chain diversification. We aim at synthesizing a population of application variants which instances are different enough, so they cannot be attacked in the same way. This is achieved because these instances do not depend on the same libraries implementations, hence are not sensitive to the same supply chain attacks.

For a given application that depends on a specific library, we propose to generate as many variants as there exist alternative libraries providing similar features. For example, from an application depending on `Apache HTTPClient`, we propose to generate a population of variants, one depending on `OkHttp`, one depending on `Eclipse Jetty`, one depending on `Jode HTTP`, etc. This population would include one variant per alternative library that `Apache HTTPClient` can be substituted with, without breaking the functionalities of the original application.

To produce these variants, we propose a generic architecture for library substitution. A Library Substitution Framework is specialized for a reservoir, and supports the generation of variants, each based on an alternative library of the reservoir. Overall, the goal of such a framework is to maximize the number of variants that can be created from a single client application, depending on a library of the reservoir.

However, substituting a library by an alternative raises significant challenges because of client-library entanglement and API discrepancies. In the following sections, we propose a general architecture that addresses these challenges.

3.2 Library Adapters

The key challenge for automatic library substitution lies in the tight entanglement between an application and the APIs of its third-party libraries (top part of Figure 1). To support substituting a library by another in the same reservoir,

1. <https://mvnrepository.com/open-source/http-clients>

we propose to introduce one level of indirection between an API and its implementation. Keeping the original API allows us to support library substitution without modifying the code of the client application. The level of indirection between the API and an implementation is a piece of software that binds the API elements to elements of the implementation. We call this piece of software an *adapter*. Figure 1 illustrates the concept. It represents a client that depends on a library A0. The client includes invocations to the API of A0. Hence, replacing A0 by A1 is not possible, as A1 exposes a different API. An *adapter* from A0 to A1 exposes the same API as A0, and it implements wrappers for all API elements of A0 that adapt the calls towards A1. For example, an adapter from `Apache HttpClient` to `OkHTTP` would provide the API of `Apache HttpClient` (with types such as `CloseableHttpClient`) but calls to this API would be translated to calls to the API of `OkHTTP`.

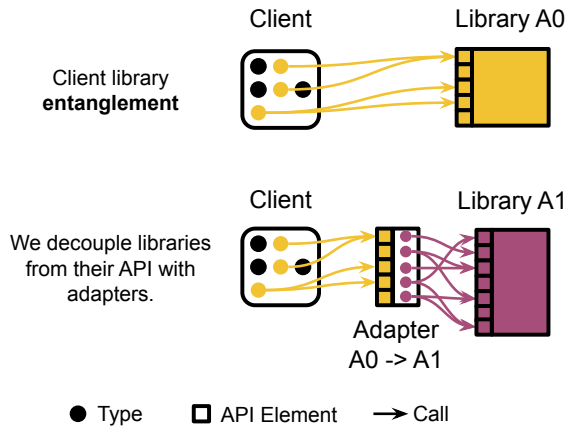

Fig. 1. To support library substitution, we propose to define adapters between the API of a third-party library and other libraries from the same reservoir. Untangling ‘behind’ the API allows us to substitute similar libraries with no modification in the client application code.

3.3 Library Substitution Framework Architecture

In this section, we refine the high-level concept of *adapter* into a generic architecture to build a Library Substitution Framework. In particular, this architecture aims at limiting the development effort related to the high number of API elements to adapt. A naive approach would implement an adapter for each pair of libraries in a given reservoir, with each adapter implementing the full API of the library being adapted. For a reservoir containing n libraries, the number of API element implementations that the framework needs to provide is computed with:

$$\sum_{i=0}^n \#Version_{API_i} \times Size_{API_i} \times (n - 1) \quad (1)$$

Indeed, for each version ($\#Version_{API_i}$) of each of the n libraries in the reservoir, every API element ($Size_{API_i}$) needs to be re-written with each of the $n - 1$ other libraries of the reservoir. The amount of code to be developed, tested, and maintained makes this naive approach impractical for large library reservoirs.

We leverage one key observation to limit the development effort for adapters: the distributions of usages among libraries in a reservoir[26], among versions[27] and among the API members[28], are skewed towards a handful of popular elements. If the designers of a Library Substitution Framework accept to build a solution that is effective for a majority of client applications in a given domain, instead of all of them, then, the complexity of the framework can be significantly reduced. We discuss each point in the following paragraphs.

Size of APIs: The number of elements exposed by a library’s API can be large. For example, among the 100 most popular libraries of Maven Central, the median number of public types is 202, the median number of methods 1,815 and the median number of public fields 148 [28]. There might be some client applications that depend on these elements. Consequently, a Library Substitution Framework shall support all these API elements to provide diversity to all applications. However, the vast majority of clients rely on a small subset of the original APIs [28]. Consequently, framework designers can provide adapters that focus on the most popular subset of the original libraries’ API.

Number of versions: A library is released through multiple versions, and all versions are available on the online repositories. For example, in Maven Central, there are between 5 and 200 different versions for 50% of the libraries [27]. Each new version potentially changes the API of the library. To support all clients of all versions of a library, the adapter needs to support the union of the APIs of all versions. However, only a handful of versions are used by a majority of clients [27]. This implies that a Library Substitution Framework can focus on the most popular version of each library. Furthermore, the subset of popular API elements of a library does not necessarily change for every version [29]. Hence, the most popular version of an API may also be compatible with clients of other versions.

Number of Alternative Libraries: Developing adapters for each library in a reservoir can be challenging, in particular for a large reservoir. For example, *mvnrepository.com* lists more than 80 different HTTP clients libraries for the JVM, or more than 40 different logging frameworks. Designers can focus on supporting a minority of popular libraries. Consequently, their Library Substitution Framework will not be usable for the few client applications that use the least popular libraries in the reservoir.

In addition to the curation of the API to adapt, we propose a generic architecture for a Library Substitution Framework. In particular, this architecture addresses the problem of the number of possible substitutions. The number of alternative libraries also increases quadratically the number of combinations of substitution possible. To limit this quadratic explosion, we rely on the inversion of control pattern [30]. We implement adapters between the APIs used by the client applications and a common, abstract API that captures the core set of features shared by all libraries in the reservoir. We then implement adapters between this common API towards each library of the reservoir. Hence, the actual library can be changed seamlessly. Figure 2 describes the proposed three layers architecture.

Bridge: A bridge aims at abstracting the API of a library used by a client, without modifying the code of the client.

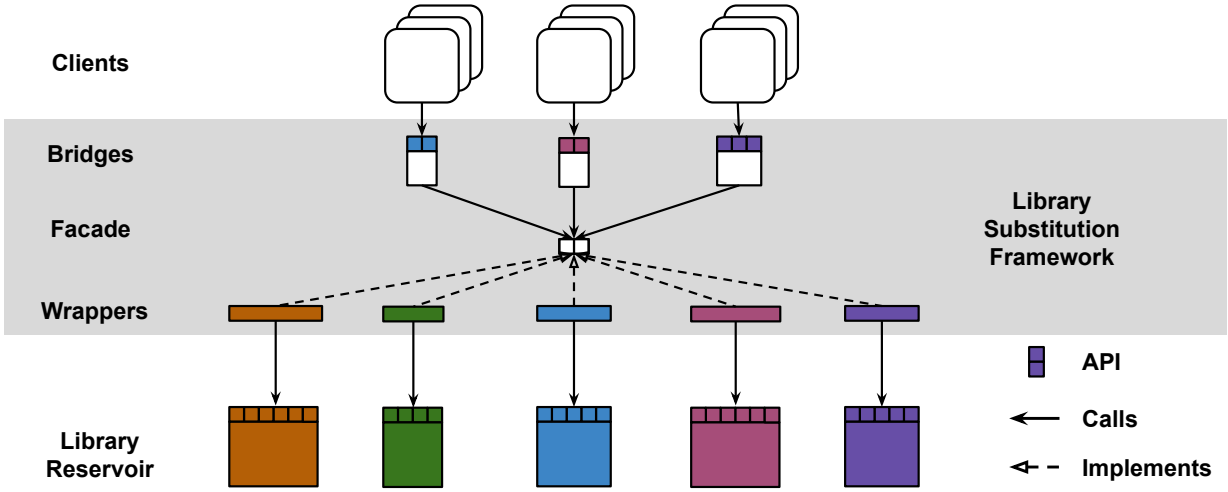

Fig. 2. Generic architecture for a Library Substitution Framework that targets a set of applications and a library reservoir. Bridges abstract the API used by the clients from the concrete implementation; the facade defines a common API for all libraries; a wrapper maps the abstract API to the concrete functions of an existing library of the reservoir.

To do so, a bridge presents to its clients the same API (or a subset) as the library it substitutes. The actual implementation of the bridge actually transfers method calls to objects implementing common interfaces contained in the facade. A bridge ensures the syntactic correctness of the substitution. To summarize, a bridge is an adapter from the API of the library it substitutes towards the API described in the facade.

Facade: A facade specifies a set of abstract operations that capture the core set of features that are provided by all libraries in the reservoir. It defines a common API that bridges use. It also defines a Factory that instantiates a concrete library that will provide these operations, providing the inversion of control mechanism [30].

Wrapper: A wrapper is an adapter from the API described in the facade towards an existing alternative library. It provides the concrete behavior for the operations specified in the facade. To be part of this architecture for substitution, the library must be extended with adapted classes that relate the operations of the facade with the concrete classes of the library. The more libraries naturally available in a reservoir, the more behavior diversity we can introduce for the client applications.

With this architecture, a client application can benefit from the alternative libraries by replacing, in the configuration file of its package manager, the original dependency by its corresponding bridge and the desired wrapper. The pair Bridge / Wrapper constitutes the adapter from the bridged library to the wrapped one.

The architecture of Figure 2 combined with the API curating, greatly reduces, the number of API elements to be adapted, which can be revised from (1) to:

$$\sum_{i=0}^m \text{Size}_{Most_Used_Elements}(API_i) + \sum_{i=0}^n \text{Size}_{Facade} \quad (2)$$

with $m \ll n$

First, only the most popular version of an API is selected, second, only the most popular elements of the m most

popular APIs are adapted, and they are adapted only once thanks to the facade. Then, each API element of the facade is implemented once per library (n) in the reservoir. It is important to note that this approach scales linearly with the number of libraries n in the reservoir, rather than quadratically. Furthermore, this architecture makes the addition of new libraries to the reservoir simpler to handle. Indeed, both the development of a new bridge and a new wrapper only require knowledge of the API of the new library and the facade.

3.4 Assessment Criteria for Library Substitution Frameworks

To evaluate the relevance of the concept of Library Substitution Framework proposed in this work, as well as the architecture described in this section, we formulate 4 criteria, associated to 4 metrics

Minimal number of API elements to adapt: An important aspect of the architecture we propose in this work, lies in curating the APIs to adapt. The metric to observe, regarding that aspect, is the number of API elements that actually need to be adapted.

Preservation of the behavior of the bridged libraries: Given a bridged library, the bridge should behave as the original library, with all implementations in a reservoir. In order to assess the behavior preservation, we rely on the existing test suite of the library. We measure this with respect to the number of tests of a library that pass on its corresponding bridge coupled with each wrapper in the reservoir.

Maximize the share of clients supported by the bridge APIs: A bridged library does not adapt all API elements of the original library. Still, a Library Substitution Framework aims at supporting the diversification of a maximum number of applications. We measure the effectiveness of this trade-off with the share of clients that compile when a library is substituted by its corresponding bridge.

Maximize the number of behavior preserving variants per client: The main goal of a Library Substitution Frame-

work is to diversify the supply chain of the applications that depend on library of a reservoir. Meanwhile, diversification must preserve the original behavior of the application. Here, we count the number of application variants that pass the original test suite, after substituting the original dependency by one of the implementations in the reservoir.

4 EXPERIMENTAL PROTOCOL

The architecture, presented in the previous section, is generic and aims at being instantiated for specific library reservoirs. To evaluate the feasibility, and the effectiveness of Library Substitution Framework, we implement a case study for the reservoir of Java JSON libraries.

JavaScript Object Notation, or JSON, is a ubiquitous file and data exchange format. Since its creation in 1999, it has gained considerable popularity for a wide spectrum of activities such as web APIs [31], scientific computing [32], data management [33], or gaming [34]. It is also used as a serialization format for Java objects. Serialization is known to be vulnerability prone [35], [36], [37], and JSON libraries are no exception [38]. For example, `jackson-databind`, the most popular Java JSON library is referenced in at least 68 CVE [39]. This makes JSON libraries good targets for supply chain attacks on third-party packages. Therefore, the reservoir of JSON libraries [26] is a relevant target to experiment the concept of Library Substitution Framework.

4.1 Research Questions

In Section 3, we introduced a general architecture for a Library Substitution Framework that supports the automatic build of variant application with diverse suppliers. We validate our approach for JSON through 5 RQs: 2 that focus on validating the architecture and 3 that validate the support to build variants.

The first group of research question assesses the feasibility of implementing a Library Substitution Framework as described in Section 3.3, and testing its features. To answer these questions, we focus on the *libraries* of the reservoir.

RQ1. Can the architecture we propose for a Library Substitution Framework be implemented from a concrete reservoir of libraries?

In this first research question, we implement ARGO, a Library Substitution Framework for JSON libraries. We follow the process of curating APIs and the general architecture described in Section 3.3. We describe the design decisions such as the choices of bridged libraries, the choice of features to include in the facade, as well as the implementation of wrappers. We then discuss the impact of these choices on the number of API elements adapted in the framework.

RQ2. Can the test suite of libraries, be curated and reused to test a Library Substitution Framework?

In this research question, we investigate to what extent we can reuse the test suites of the bridged libraries to validate a Library Substitution Framework. We carefully curate the test suites of the 4 libraries bridged in ARGO. We then run these test suites on each of the 80 combinations of bridges and wrappers available in the framework. This reuse of tests across libraries of the same domain is in part similar to the work of Sondhi and colleagues [17].

In research questions 3, 4 and 5, we assess the impact of a Library Substitution Framework on *clients* of libraries from the targeted reservoir. These questions focus on the impact of ARGO on the clients of JSON libraries.

RQ3. What is the share of clients for which the framework preserves the static semantics of the original dependency? In this research question, we assess which clients compile correctly when replacing the original library by the corresponding bridge. This means that all API members used by a client do have a substitution provided by ARGO. We also investigate cases where this condition is not met. This allows us to study the consequences of the tradeoff, described in Section 3.3, between the size of the APIs bridged and the number of supported clients.

RQ4. How many variants can we produce for each client, while preserving the original behavior? This research question is at the core of our work. Here, we measure the number of JSON libraries we can automatically substitute while preserving the original behavior of the clients, as specified by their test suites. The larger number of libraries we can substitute, the more diversity of providers ARGO can support in the supply chain of the clients.

RQ5. How can clients increase the diversity of their providers? When the test suite of a client fails, the substitution of the library it uses, it gives us indications on what makes clients tied to a specific JSON library. By analyzing these test failures, we draw general principles that make clients less coupled with a library and more prone to diversification.

4.2 Datasets

In this section we present the two datasets we build to study our two groups of research questions. First, we collect a reservoir of Java JSON library to build a concrete Library Substitution Framework, described in Section 4.2.1. Second, we gather a set of clients of the most popular libraries in this reservoir, described in Section 4.2.2, to study the impact of our framework.

4.2.1 JSON Library Reservoir

Our reservoir of Java JSON libraries includes 20 libraries available on Maven Central, all providing (i) JSON parsing features, and (ii) serialization to JSON text. These libraries have been designed by different people with different motivations. We have previously analyzed the behavior of this reservoir in depth [26]. In our previous work, we make three points that are of interest for this work: (i) these libraries make a large variety of design decisions to represent JSON data; (ii) these libraries exhibit a large diversity of behaviors regarding what JSON inputs they consider as well-formed or ill-formed; (iii) there is more diversity of behaviors observed on JSON inputs that do not conform to the standard grammar [40].

Table 1 describes our reservoir of JSON libraries. Column `#COMMITTS` indicates the number of commits in the source repository of the library, when available. Column `#STARS` gives the number of stars each library has, when hosted on GitHub. As described in Section 3.3, supporting all versions of all libraries, is a large effort. Hence, we focus on the most popular version of each library. Column `VERSION` shows the

| LIBRARY | # COMMITS | # STARS | VERSION | BRIDGED |
|-------------|-----------|---------|--------------|---------|
| gson | 1485 | 18.8k | 2.8.5 | ✓ |
| jackson | 7382 | 2.7k | 2.12.0-rc2 | ✓ |
| json | 841 | 3.7k | 20201115 | ✓ |
| json-simple | - | 594 | 1.1.1 | ✓ |
| cookjson | 116 | 3 | 1.0.2 | |
| corn | - | - | 1.0.8 | |
| fastjson | 3793 | 1.4k | 1.2.75 | |
| flexjson | - | - | 3.3 | |
| genson | 395 | 193 | 1.6 | |
| jjson | 216 | 12 | 0.1.7 | |
| johnzon | 780 | - | 1.1.8 | |
| json-argo | - | - | 5.13 | |
| json-io | 1040 | 268 | 4.12.0 | |
| json-lib | - | - | 3.0.1 | |
| json-util | 464 | 48 | 1.10.4-java7 | |
| jsonij | 348 | - | 0.3.1 | |
| jsonp | 530 | 75 | 2.0.0 | |
| mjson | 79 | 67 | 1.4.0 | |
| progbase | - | - | 0.4.0 | |
| sojo | - | - | 1.0.13 | |

TABLE 1

Description of the JSON libraries studied by *Harrand et al.* [26]

version selected to build ARGO. Finally, we select the API of 4 of the most popular libraries, `jackson-databind`, `gson`, `org.json`, `json-simple` for which we develop bridges. We also collect their respective test suites to assess the preservation of their features by ARGO.

PLACEBO JSON library: We want to verify that, when we substitute a library by another, the new library, provided by the framework, is actually covered by the test suite. To do so, we add another wrapper to the 20 existing libraries. PLACEBO is a special wrapper. It contains classes that implement the complete interfaces of the facade, and all of its methods directly throw an exception when invoked. Hence, when a JSON library is substituted with PLACEBO, two things can happen: (i) the execution of the test suite triggers an exception from PLACEBO and fails; (ii) or the test suite passes without triggering any exception. If no exception is triggered, we conclude that the test suite does not cover the usage of the JSON library. Hence, the test suite cannot be used to assess if the library substitution was successful. If an exception is triggered, the JSON library usage is covered by the test suite.

4.2.2 Client of JSON Libraries

In this section, we describe the methodology that we follow to construct the dataset of open-source Maven Java projects that use JSON libraries. We choose open-source projects in order to have a large diversity of library usages, and to study the impact of library substitution. We want open-source projects that have a reproducible build, use a JSON library, and have reproducible tests that do cover the JSON library in question.

The construction of this benchmark is composed of 4 main steps. (i) First, we identify the 147,991 Java projects on GitHub that have at least five stars. We use the stars as an indicator of interest. (ii) Second, we select 54,703/147,991 (37.0%) Maven projects. We choose Maven projects to be able to build and execute the tests of the projects automatically. (iii) Third, we parse each Maven build configuration

file to identify the projects that use any version of a JSON library. During this step, we identify 12,012/54,703 (22.0%) projects. (iv) As the fourth step, we execute three times the test suite of all the projects, as a sanity check to filter out projects that we cannot build and the projects with flaky tests. We keep the projects that have at least one test and have all the tests passing: 1,927/12,012 (16.0%) projects passed this verification.

This gives us 1,927 client projects that declare a dependency towards a JSON library and that can build. We run an additional check to verify that the test suite of the client covers the usage of the JSON library. Indeed, a test suite that does not cover the JSON library, would pass regardless of whether our substitution is satisfactory or not. We substitute the JSON library of these clients by the corresponding bridge and the PLACEBO implementation. If the test suite of the client passes, it means that the client does not actually need `gson` to run. In that case, we remove the client from the dataset.

Our final dataset consists of 368 client projects distributed as shown in Table 2. Column #CLIENT indicates the number of clients for each library, #TEST shows the combined number of tests provided by their test suite, and #JSON TEST gives the number of these tests that cover the usage of a JSON library. This number is obtained by checking the number of test failures with the PLACEBO wrapper.

| LIBRARY | #CLIENT | #TEST | #JSON TEST |
|------------------|---------|---------|------------|
| jackson-databind | 128 | 636,664 | 127,054 |
| gson | 122 | 201,576 | 6,891 |
| json | 84 | 84,030 | 10,835 |
| json-simple | 34 | 37,804 | 1,065 |
| Total | 368 | 960,074 | 145,845 |

TABLE 2
JSON library clients studied

4.3 Experimental Protocol

4.3.1 Library Substitution Framework design and test (RQs 1 & 2)

The goal of our two first research questions is to assess the feasibility of implementing and testing the architecture described in Section 3.3. Figure 3 gives an overview of our process to answer these questions.

RQ1 protocol: To answer the first question, we implement ARGO, a Library Substitution Framework for the JSON library reservoir described in Section 4.2.1. In order to bring down the development effort, we follow the process of API curation described in Section 3.3. We focus on the most used version of each library of the reservoir. We develop a bridge for 4 of the most popular libraries: `jackson-databind`, `gson`, `org.json` and `json-simple`. In these bridges, we only adapt the most used API elements that correspond to the features shared by all libraries of the reservoir. We assess the popularity of API elements by static analysis of the clients' dataset described in Section 4.2.2. To perform this static analysis, we reuse the tool develop for a previous study [28].

We define a common API that describes the common features, which we package as the facade of our framework.

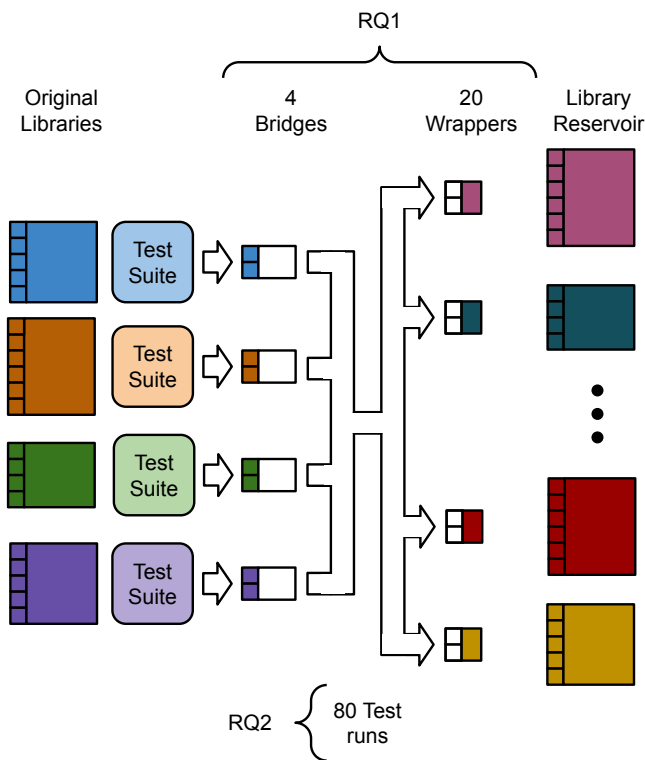

Fig. 3. Design (RQ1) and test (RQ2) of ARGO, our concrete Library Substitution Framework for the JSON library reservoir. In RQ1 we design and implement the facade, 4 bridges, and 20 wrappers. In RQ2, we curate and reuse the test suites of the 4 bridged libraries, to run them on all combinations of bridges and wrappers.

These features are JSON text parsing, JSON type representation as Java Object, and data serialization as JSON text. Finally, we write a wrapper for each of the 20 libraries of the reservoir. We then evaluate this API curating process by discussing the number of API elements adapted compared to the total number of API elements in the reservoir.

RQ2 protocol: Once ARGO is implemented, we run the test suite of the 4 bridged libraries against their corresponding bridge in order to assess what functionalities of the 20 libraries are preserved. This assessment is based on a two-step protocol: (1) First, we curate the original test suite to select a subset of the original test suite that is relevant to test ARGO; (2) we run this curated test suite on the corresponding bridge and each of the 20 wrappers supported by ARGO.

First, we follow the test selection process described in Figure 4. Given one original JSON library, we extract its test suite and add a dependency to the corresponding bridge and implementation. For example, we take the test suite of `org.json`, and add a dependency towards `json-over-argo` and `argo-json`. Hence, when a test case refers to a class from the original library, the corresponding class from the bridge is loaded instead. (1) First, we compile the test suite. Some test cases do not compile because the bridge does not implement the feature targeted by the test. We remove those tests. Then, we run the test suite on the bridge with the PLACEBO wrapper (2). We comment-out tests that pass despite the wrapper being

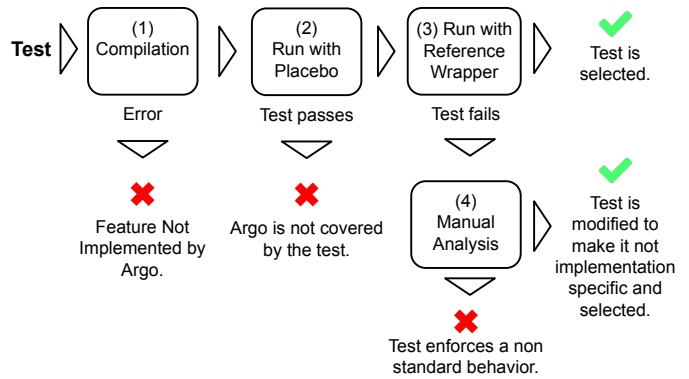

Fig. 4. Protocol to select tests relevant to Library Substitution Framework validation from the test suite of the bridged libraries. Tests need to cover adapted API elements, while not enforcing a non-standard behavior.

empty and label them as PLACEBO. At the end of this test suite execution, we obtain a subset of the original test suite, composed exclusively of the test cases and assertions that assess the behavior of the bridge.

We execute the test cases that are not labelled PLACEBO, with the bridge and the wrapper that corresponds to the original library (3). We select all the tests that pass on this implementation. If some test cases fail, we manually analyze them to determine whether to modify them or to remove them (4). We remove tests that specify a behavior stricter than what is described in RFC 8259 [40]. The tests we modify are adapted in two ways. One is to relax assertions that assess strict equality of JSON strings to make them tolerant to equivalent JSON strings: make JSON text equality check tolerant to white spaces or JSON object tolerant to key reordering. The second is the relaxation of the number comparisons to make them tolerant to different types (removing unchecked casts, making floating-point comparison modulo epsilon, etc.). As a sanity check, we re-run the whole selected test suite to make sure that every test fails on PLACEBO and succeeds on the reference wrapper.

The second main step of the protocol for RQ2 consists in running the selected test cases with every other library, to determine how much of the original behavior is preserved by the variants present in ARGO. We then analyze the reasons for eventual failures.

4.3.2 Client Experiments (RQs 3, 4 & 5)

Our second set of RQs assesses whether we can generate application variants through library substitution. To answer them, we substitute the JSON library, used by the clients of the dataset described Section 4.2.2, by alternatives provided by ARGO. Figure 5 describes the flow of our experiment. For each client, we substitute the JSON library and replace it by the corresponding bridge. Since all of our clients are Maven project, to perform substitutions, we edit the `pom.xml` files of clients. This allows us to alter the classpath of the client both during compilation and test execution.

RQ3 protocol: We analyze the result of compiling each client, where the original JSON library has been substituted by the corresponding bridge. Our dataset only contains client projects for which we can reproduce the build. Consequently, a build failure with the bridge indicates that there

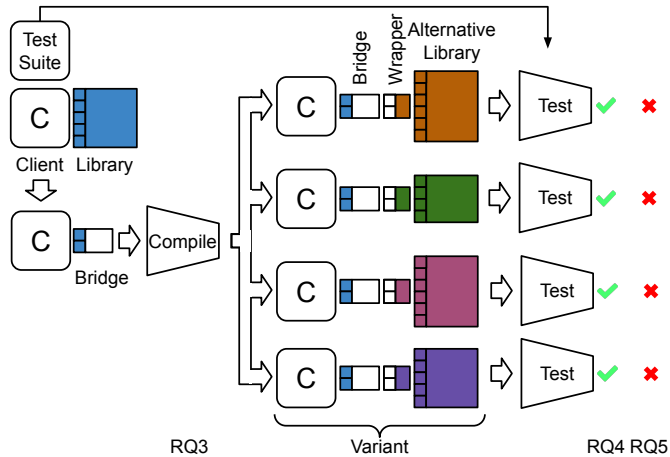

Fig. 5. The flow of experiments on JSON libraries' clients. For each client, we substitute the original library by its corresponding bridge. We, then, compile the client to detect potential missing API elements from the bridge (RQ3). If compilation succeeds, we generate 20 variants per client, one per library in the reservoir. We run the clients' original test suites on each variant. We then analyze test successes (RQ4) and failures (RQ5).

are static differences between the part of the API of the original library used by the client and its ARGO counterpart. By contrast, when no compilation error occurs, it means that all API members statically called by the clients are exposed by the bridge.

RQ4 protocol: In RQ4, we measure the number of behaviorally equivalent variants we can generate through library substitution. We focus on clients for which the substitution of the library, by its corresponding bridge, leads to successful compilation. For each client, we generate 20 variants, one per library in the reservoir described in Section 4.2.1. A variant is composed of the original client, a bridge, a wrapper and one alternative library. We run the test suite of these clients on each of the 20 variants. We assess if variants are behaviorally equivalent, by checking whether the client's test suite passes, without test failures, on them. Our dataset only contains clients for which the test suite covers the usage of the original JSON library, as a substitution with the PLACEBO wrapper makes their test suite fail. Hence, we know that the substituted library is covered by at least one test in the client's test suite. We then count for each client the number of behaviorally equivalent variants. This number of variants is the number of alternatives that our Library Substitution Framework provides for a given client.

RQ5 protocol: In RQ5, we manually investigate clients for which we obtain test failures after library substitution. We rerun failing tests with a debugger to investigate the root cause of their failure. From these analyses, we draw principles that enable developers to decouple clients from their libraries. We discuss these principles and give examples of tests that do not respect them.

5 RESULTS

5.1 RQ1. Can the architecture we propose for a Library Substitution Framework be implemented from a concrete reservoir of libraries?

In this research question, we assess the feasibility of implementing a Library Substitution Framework that follows the architecture described in Section 3.3. To evaluate the development cost of such an endeavor, we implement a concrete framework, ARGO, for the reservoir of JSON libraries described in Section 4.2.1. We focus on the features that are shared by all the 20 libraries of the reservoir: parsing JSON text into Java objects and serializing these objects back to JSON text. In the remaining of this section, we discuss in detail our design decisions. We also discuss the effect of our proposed architecture on the development effort through the lens of API elements adapted.

| LIBRARY | #API_ELEMENTS | #API_BRIDGE | #API_WRAPPER |
|------------------|---------------|-------------|--------------|
| gson | 468 | 60 | 26 |
| jackson-databind | 5807 | 79 | 36 |
| json | 301 | 123 | 9 |
| json-simple | 102 | 74 | 8 |
| cookjson | 279 | - | 23 |
| corn | 146 | - | 21 |
| fastjson | 1860 | - | 12 |
| flexjson | 326 | - | 6 |
| genson | 747 | - | 4 |
| jjson | 42 | - | 19 |
| johnzon | 199 | - | 13 |
| json-argo | 221 | - | 34 |
| json-io | 230 | - | 6 |
| json-lib | 651 | - | 5 |
| json-util | 296 | - | 2 |
| jsonij | 714 | - | 11 |
| jsonp | 392 | - | 14 |
| mjson | 77 | - | 71 |
| progbase | 312 | - | 2 |
| sojo | 788 | - | 4 |

TABLE 3
Description of the APIs of the JSON reservoir

Table 3 summarizes the design decisions taken concerning API curating, in our implementation of ARGO. Column #VERSION indicates the number of versions listed by *mvnrepository.com* for each of the 20 libraries of the reservoir. We decide to focus on only the most popular version of each of these libraries. We estimate the popularity of library version based on the clients we mine from GitHub in Section 4.2.2. Column #API_ELEMENTS gives the number of public elements (constructors, methods and fields), in the most popular version of each library. Each of these elements may be called by any clients of the library. Column #API_BRIDGE shows the number of API elements adapted in the bridges. These elements' code is rewritten using calls to elements of ARGO's facade. These numbers are provided for the subset of the most popular libraries for which we have chosen to implement a bridge. Column #API_WRAPPER indicates the number of API elements of the original libraries used in ARGO's wrappers. In the remaining of this section, we discuss these numbers with

more details by going through each layer of the architecture: bridges, facade and wrappers.

Bridges: We select 4 out of the 5 most popular libraries in the reservoir: `jackson-databind`, `gson`, `org.json`, and `json-simple`. Bridges are implemented by replacing calls to parsing and serialization to their abstract counterparts described in the facade, and by replacing JSON data structure classes by classes containing a type from the facade and redirecting method calls to their equivalent described by the facade on the contained type. We implement a bridge from the most popular version of those 4 libraries towards our facade. The column `#API_BRIDGE` of Table 3 shows the number of API elements adapted for each bridge. They range from 60 for `gson` to 123 for `org.json`. This represents a small proportion of their respective API size (ranging from 102 elements up to 5,807). The sources of our bridges are available online.²

Facade: We identify a common set of features for all of our 4 bridged libraries. We rely both on knowledge of the JSON subject, and on the manual analysis of the libraries in the reservoir to identify three key, core features, which we specify in the facade: parsing JSON text into Java structures, serializing these structures to JSON text, and representing JSON types with Java structures. We observe that 15 out of 20 libraries propose a type for JSON object and 14 for JSON arrays [26]. The other libraries represent these data as types of the Java standard library, implementing either a Map or a List (or in one case a primitive array). Therefore, we include these types in the facade. We also add a type to represent the JSON value Null. As the other JSON types (String, Number, and Boolean) are more often represented by types from the Java standard library, we do not impose any choice in our facade. In total, the facade includes 3 interfaces (JSON object, JSON array and JSON factory), regrouping 15 methods to be implemented by each of the 20 wrappers.

Wrapper: Writing a wrapper consists in implementing the interfaces provided by the facade with the API of an existing library of the reservoir. The column `#API_WRAPPER` of Table 3 shows the number of API elements of the targeted library used in our wrapper. They range from 2 for `progbase` and `json-util` up to 48 for `mjson`. We first implement the interface, described in the facade, responsible for JSON text parsing and the creation of concrete JSON object from the library being wrapped. This operation is either implemented through the constructors of the class representing JSON object and JSON array, in a factory class or in a class representing the parser. Second, we adapt serialization operation to serialization methods of the facade. Finally, we add an implementation for the interface of the facade representing JSON object and JSON array based on the existing class of the library, either by extending the class in question or by creating a container type. When no such class exists, we create a container type for the class of the Java standard library used by the library. This is the case for 5 libraries: `flexjson`, `genson`, `json-util`, `progbase` and `sojo`, which explains the relatively low number of API elements used. In the most extreme case, `progbase`, only two API elements are used: `JSONObjectReader.readJSON`,

the parser and `JSONObjectWriter.writeJSON`, the serializer. We also intercept null values used to represent the JSON Null value and replace them by the type of the facade. We do write this wrapper for all 20 libraries in our dataset. The sources of our wrappers are available online.³

With the JSON reservoir presented in Table 3 a naive approach for the development of adapters would require the development of an adapter from each API element of each version of the 20 libraries towards the 19 other libraries. Assuming that the number of API elements for each library does not drastically vary among versions, then, the naive approach would require 27 millions of elements to be adapted following the calculus (1) presented in Section 3.3. Even if we focused on one version per library, this would still mean adapting 13,958 API elements to each of the 19 other libraries, or a total of 265,202 adapters. Instead, using the revised calculus (2), we adapt a total of 336 elements in our 4 bridges, and 20×15 (300) in our wrappers. This represents a total of 636 adapters. This reduction from 265,202 to 636 adapters results from a careful selection of a subset of libraries and APIs to build the bridges of ARGO, as well as from the architecture based on inversion of control and an abstract facade. The experiments in the following sections show that the drastic reduction of API elements still allows diversifying the supply chain of a large number of clients.

Answer to RQ1. With ARGO, a concrete Library Substitution Framework for the reservoir of JSON libraries, we demonstrate that such an implementation is feasible. After API curating, we design bridges that adapt the most used API elements representing the common features of the reservoir. This process reduces the number of API element adaptations from 265,202 to 636.

5.2 RQ2. Can the test suite of libraries, be curated and reused to test a Library Substitution Framework?

We investigate how ARGO’s 20 libraries preserve an equivalent behavior, modulo test, for the 4 bridges we developed. We first discuss the outcome of curating the original test suites of the 4 bridged libraries. Second, we run the curated test suites with the bridges and each library of the reservoir, and discuss the outcome.

5.2.1 Test Selection

| LIBRARY | #ORIGINAL | #REMOVED | #PLACEBO | #SELECTED |
|--------------------------|-----------|----------|----------|-----------|
| <code>gson</code> | 1,051 | 0 | 918 | 133 |
| <code>jackson</code> | 2,473 | 0 | 2,332 | 141 |
| <code>json</code> | 328 | 230 | 9 | 89 |
| <code>json-simple</code> | 29 | 1 | 1 | 27 |
| Total | 3,881 | 231 | 3,260 | 390 |

TABLE 4
Results of test selection to assess the correctness of ARGO.

2. <https://github.com/nharrand/argo>

3. <https://github.com/nharrand/argo>

Table 4 gives the details of the test selection for each original test suite. The second column gives the number of tests present in that original test suite. The third column gives the number of tests that were removed because they call API elements not supported by the bridge. The fourth column indicates the number of tests that we discard because they pass on the PLACEBO wrapper and therefore would pass with any library. The last column indicates the number of tests that we have selected to run with each library in the reservoir. For example, the `gson` test suite originally contained 1,051 tests, from which we removed none for compilation reasons, 918 were labelled as PLACEBO and 133 were selected.

In total, we assembled 4 curated test suites combining 390 tests. We can see two different trends. `gson` and `jackson-databind` are large libraries that expose many features, beyond just JSON serialization, parsing and JSON data structure. Some of these features are unmodified in our bridges as they are not shared by the other libraries, and therefore unaffected by ARGO. By unmodified, we mean that we keep the source code from the original library. This explains the large number of PLACEBO tests that we discard. Note that, by definition, those tests would pass with any wrapper of ARGO. On the other hand, `org.json` proposes a large API that we do not fully support in our bridge as few clients rely on it, hence the large number of tests that do not compile because of features that we do not support. Those tests do call API elements that we dismissed in our bridges.

```

1 JSONParser parser = new JSONParser();
2 s="{\"name\":\"\"";
3 try {
4   obj = parser.parse(s);
5 } catch(ParseException pe) {
6   //ORIGINAL
7   assertEquals(
8     ParseException.ERROR_UNEXPECTED_TOKEN,
9     pe.getErrorType());
10  //ERROR_HANDLING
11  //assertEquals(8, pe.getPosition());
12 }

```

Listing 1. Test excerpt from `org.json` checking an error message, modified in our curated test suite.

We modify 17 tests, across the 4 test suites, by deactivating assertions that specify the error behavior of the original library. Error handling behavior is very diverse among our libraries and, hence, difficult to reproduce with every other library. Listing 1 is an excerpt of a test that checks the behavior of `json-simple`'s parser when encountering an ill-formed JSON input. When `json-simple`'s parser encounters an error, gives its position to its client. The client can then decide what to do with the partially parsed JSON text. Some libraries, such as `org.json`, fail without giving the position of the error. Other libraries, consider the error to be positioned somewhere else. Hence, it is possible to preserve the fact that an exception is thrown for an ill-formed input, but not necessarily the error message or partially parsed data. Therefore, we keep the assertion that specifies that an exception is thrown (Line 7), but we deactivate the assertion that specifies the content of the exception (Line 11).

5.2.2 Behavior Preservation

Table 5 presents the outcomes for the curated test suites on each pair of bridge and wrapper in ARGO. Each column corresponds to one of the 4 bridges, and each line corresponds to one of the 20 wrappers. Each cell gives the number of tests of the original test suite that pass with the bridged library, indicating behavior preservation. Cells in green show wrappers that passed all tests, cells colored in yellow represent wrappers that failed less than 10% of the test suite, and in red are the wrappers that failed more than 10% of the test suite. For example, the first line shows that all the curated tests for `gson` pass with the `gson` bridge and the `cookjson` wrapper; 6 out of the 141 curated `jackson-databind` tests fail with the `jackson-databind` bridge and the `cookjson` wrapper; all the `json` tests and the `json-simple` tests pass with their respective bridges and the `cookjson` wrapper.

| IMPLEMENTATION | GSON | JACKSON | JSON | JSON-SIMPLE |
|-------------------------------|-----------|-----------|---------|-------------|
| <code>cookjson</code> | 133 / 133 | 135 / 141 | 89 / 89 | 27 / 27 |
| <code>corn</code> | 133 / 133 | 136 / 141 | 82 / 89 | 27 / 27 |
| <code>fastjson</code> | 133 / 133 | 141 / 141 | 89 / 89 | 27 / 27 |
| <code>flexjson</code> | 133 / 133 | 141 / 141 | 88 / 89 | 27 / 27 |
| <code>genson</code> | 133 / 133 | 141 / 141 | 89 / 89 | 27 / 27 |
| <code>gson</code> | 133 / 133 | 137 / 141 | 89 / 89 | 27 / 27 |
| <code>jackson-databind</code> | 133 / 133 | 141 / 141 | 86 / 89 | 27 / 27 |
| <code>jjson</code> | 131 / 133 | 131 / 141 | 71 / 89 | 25 / 27 |
| <code>johnzon</code> | 133 / 133 | 141 / 141 | 89 / 89 | 27 / 27 |
| <code>json</code> | 132 / 133 | 141 / 141 | 89 / 89 | 27 / 27 |
| <code>json-argo</code> | 133 / 133 | 141 / 141 | 89 / 89 | 27 / 27 |
| <code>json-io</code> | 133 / 133 | 141 / 141 | 88 / 89 | 27 / 27 |
| <code>json-lib</code> | 133 / 133 | 141 / 141 | 89 / 89 | 27 / 27 |
| <code>json-simple</code> | 133 / 133 | 141 / 141 | 88 / 89 | 27 / 27 |
| <code>jsonij</code> | 133 / 133 | 141 / 141 | 89 / 89 | 27 / 27 |
| <code>jsonp</code> | 132 / 133 | 134 / 141 | 89 / 89 | 27 / 27 |
| <code>jsonutil</code> | 133 / 133 | 141 / 141 | 88 / 89 | 26 / 27 |
| <code>mjson</code> | 113 / 133 | 119 / 141 | 61 / 89 | 25 / 27 |
| <code>progbase-json</code> | 133 / 133 | 141 / 141 | 79 / 89 | 27 / 27 |
| <code>sojo</code> | 133 / 133 | 141 / 141 | 87 / 89 | 25 / 27 |
| Total successes | 16 / 20 | 14 / 20 | 10 / 20 | 16 / 20 |

TABLE 5
Behavior preservation matrix for the 4 bridges on the 20 implementations in ARGO

Overall, out of the 80 test suite runs (4×20), 56 pass without any failures. This means that, 56 bridge/wrapper couples preserve the initial library's behavior. This shows that for the most part, the libraries of our reservoir share similar features with similar behaviors, which makes them prone to substitution. 19 test suite fail less than 10% of their tests, including 7 that fail a single test. 5 test suites fail more than 10% of their tests. Two wrappers (`mjson` and `jjson`) fail tests for all 4 test suites. While 4 wrappers (`fastjson`, `genson`, `json-lib`, and `jsonij`) pass all tests of all test suites. These results show that overall, most features of the original four bridged libraries are supported by ARGO.

Our analysis of the test failures reveals that libraries can fail for several reasons. First, a standard may leave room for diversity among libraries implementing it [26]. In the case of JSON, the RFC [40] leaves JSON parsers free to decide whether to accept ill-formed JSON inputs. Therefore, tests specifying the acceptance or rejection⁴ of ill-formed inputs

4. <https://github.com/google/gson/blob/f649e051411e092f0123878e16c5132500a2d01e/gson/src/test/java/com/google/gson/internal/bind/JsonTreeWriterTest.java#L131>

may fail when running on other libraries implementing different choices. Second, libraries may implement different, and not fully aligned, standards. For example, `jsonutil` implements ECMA5 and rejects keys that start with a digit⁵. Finally, some aspects of a standard may be commonly ignored by libraries (in our case, 6 libraries do not support Unicode characters).

Answer to RQ2. For 56 out of the 80 ARGO pairs of bridges and wrappers, all test cases in the curated test suite of the original bridged library pass. Moreover, less than 10% of the tests fail for 19 pairs. This is strong evidence that ARGO preserves behavior through library implementation substitution and that the developers of future Library Substitution Frameworks can reuse existing test suites for validation.

5.3 RQ3. What is the share of clients for which the framework preserves the static semantics of the original dependency?

In RQ1, we have discussed the API curating process. In `jackson-databind`'s bridge we have adapted 79 out of 5,807 original API elements, for `gson` 60 out of 468, for `org.json` 123 out of 301 and for `json-simple` 74 out of 102. In this research question, we investigate the impact of this API curation on clients of those APIs. In particular, we assess what share of the clients of the 4 bridged libraries only use API elements supported in ARGO. To assess this share, we observe the outcome of compiling the source code of clients of the datasets described in Section 4.2.2, when their JSON library is substituted by the corresponding bridge.

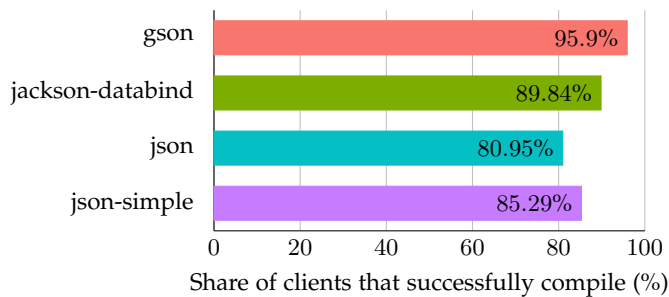

Fig. 6. Share of client projects with no compilation errors after transformation

Figure 6 shows the compilation outcome of 368 clients transformed with one of the 4 bridges in ARGO. The horizontal axis indicates the bridge, and the vertical axis the share of clients using the bridge that compile without error. For example, 115 of the 128 (89.84%) clients that originally use `jackson-databind` compile with ARGO's bridge for `jackson-databind` (`jackson-databind-over-argo`).

In total, 89.40% of clients (329 out of 368) successfully compile with an ARGO bridge instead of their original JSON dependency. This is strong evidence that the trade-off that we made between the complexity of the bridges and the

preservation of a subset of the original APIs is appropriate to successfully serve a large portion of the JSON libraries clients. In the following, we discuss the root cause for the compilation errors. In particular, we highlight that not all of them are due to missing API members in the bridges. Instead, they occur because of the intrinsic complexity of dependency resolution mechanisms.

By design, ARGO bridges do not cover the most exotic parts of the bridged libraries' API. Hence, the compilation fails when we build a client that uses an API element that is not supported in the bridge. This is the case, for example, for `Jooby`⁶, a modular web framework that depends on `org.json`. `Jooby` depends on the class `org.json.JSONTokener`, which is not included in our bridge. Hence, when replacing `org.json`, by `json-over-argo`, compilation fails. Among the 16 `org.json` clients for which ARGO transformations lead to compilation errors, 10 are due to clients relying on `org.json.JSONTokener`.

We provide a bridge for the most used version of each bridged library. Consequently, clients relying on a different version of the library may face some incompatibility when the API is substituted by the bridge. This only causes issues when the part of the API used by the client has changed in the version supported by ARGO. For example, the project `java2typescript`⁷ depends on `jackson-databind` version 2.6.4. It uses the constructor for the class `TypeBindings`, available in version 2.6.4. We support `jackson-databind` version 2.12.0 in which this constructor has become private, providing a factory method instead to create an object of this type. Hence, when replacing `jackson-databind` by its bridge `jackson-databind-over-argo` in `java2typescript`, the compilation fails.

Compilation errors occur because of dependency conflicts introduced by specific implementation choices of ARGO. For example, `netbeans-mmd-plugin` depends on `commons-codec:1.14`. But `cookjson`, one of the libraries in our JSON reservoir, depends on version 1.10 of `commons-codec`. This creates a conflict in the compilation classpath of the project when `org.json` is substituted by its ARGO bridge and the `cookjson` implementation. This conflict triggers a compilation error, since the API of `commons-codec` has changed between version 1.14 and 1.10. In particular, the method `DigestUtils.digest`⁸'s signature has changed and since version 1.11 takes a `byte[]` parameter instead of an `InputStream`. This leads the compilation of `netbeans-mmd-plugin`, that relies on the newest version of the API, to fail.

As stated in Section 5.1, the goal of our architecture is not to target all clients of all versions of the libraries in our reservoir. We have focused on a limited part of the API of one version of 4 libraries. We observe that we still provide

6. <https://github.com/jooby-project/jooby>

7. <https://github.com/raphaeljolivet/java2typescript/blob/5e3921b674bfb03ba9ac042238a8db0b9b17ca3a/java2typescript-jackson/pom.xml>

8. <https://github.com/apache/commons-codec/blob/af7b94750e2178b8437d9812b28e36ac87a455f2/src/main/java/org/apache/commons/codecs/digest/DigestUtils.java#L71>

5. <https://github.com/billdavison/JSONUtil/blob/f833a1bd7e63df30aae70984539378fdb0ee4263/JSONUtil/src/main/java/org/kopitubruk/util/json/JSONParser.java#L119>

adaptation for API elements that are enough to support 89.40% of the clients of these 4 libraries.

Answer to RQ3. The 4 JSON bridges implemented in ARGO provide an API large enough to successfully compile 89.40% of the clients in our dataset. The high rate of successful compilation is evidence that it is relevant to select a subset of a library’s API to build a Library Substitution Framework based on bridges and wrappers.

5.4 RQ4. How many variants can we produce for each client, while preserving the original behavior?

In the section, we evaluate the amount of behavior preserving variants per client, that we can generate through the use of a Library Substitution Framework. To assess which variant exhibit a behavior equivalent to the original application, we rely on the test suite of the application.

We use the 329 clients of the dataset described in Section 4.2.2 for which the substitution of the JSON library by its corresponding bridge led to no errors. For each of these clients, we build 20 variants corresponding to each of the 20 libraries of the reservoir and run the client’s test suite. We then analyze the test results and count the number of variant that are behaviorally equivalent modulo test. We ran the test suite of each client three times to limit the impact of flaky tests, the clients have 960,074 test cases, which take a total of 18.2 hours to execute. In total, we execute 2,880,222 tests cases.

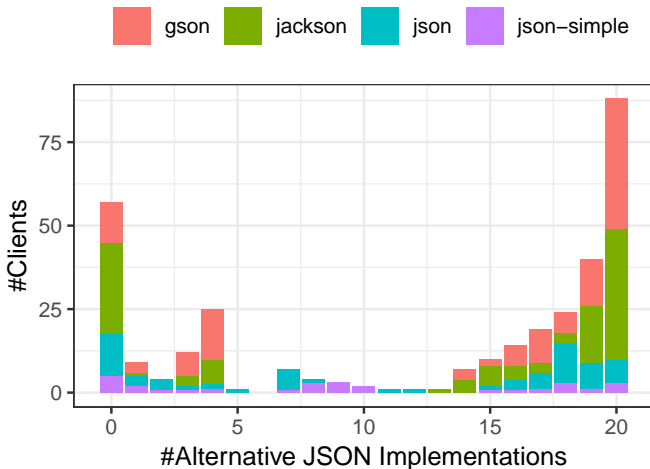

Fig. 7. Distribution of the number of successful substitution per client. We regroup the 329 clients of our dataset based on the number of JSON library substitutions (out of 20) that passed their test suite.

Figure 7 illustrates the key results for RQ3. This plot shows the cumulative number of clients for which we successfully substituted a certain number of alternative JSON libraries. The horizontal axis gives the number of alternative libraries and the vertical axis gives the number of clients. The colors indicate which bridge is used.

The right-most bar of the plot indicates that ARGO is able to substitute the original JSON library by any of the 20 alternatives for 88 clients (including the wrapper corresponding to the original library). This is a novel evidence

that it is possible to automatically increase the diversity of suppliers in the supply chain of client applications, without changing the code of these clients. Among the 88 clients, 39 build with the `gson` bridge and 39 build with the `jackson-databind` bridge, 7 with the `org.json` bridge and 3 for the `json-simple` one. This shows that library substitution are possible from any of the 4 bridged libraries towards any of the 20 libraries of the reservoir.

The other bars in the plot indicate that the majority of the other 241 clients can be provided with a large proportion of alternative JSON libraries available in our pool: 195 out of 329 (59.27%) clients can build with 14 or more alternatives. On the left of the plot, we observe that 57 clients cannot successfully run their whole test suite on any alternative library (12 for `gson`, 27 for `jackson-databind`, 13 for `JSON` and 5 for `json-simple`), and that 51 clients are compatible with between 1 and 5 JSON libraries.

In total, we successfully synthesize 4,069 behaviorally correct variants, modulo test suite, for the the 329 original clients. We can build variants, with 15 or more alternative JSON libraries, for 195 clients. In the following, we discuss two clients for which a high number of libraries can be substituted to their original JSON library.

The Automotion framework⁹ originally depends on `json-simple`. Its test suite includes 5,693 test cases that trigger invocations on the `json-simple` API. Automotion directly calls 15 different methods from 3 classes of the library (`JSONObject`, `JSONArray` and `JSONValue`). These calls are made from 13 distinct methods in `automation-java`’s code. JSON manipulation is important for this framework (evidenced by the large number of test cases), yet it is very regular: it uses functions related to JSON parsing, JSON object manipulation (read and write) and serialization. During the execution of its test suite, Automotion invokes `json-simple`’s API 39,481 times. All 20 libraries provided by ARGO can be substituted to `json-simple` and provide the proper behavior for these thousands of invocations, without breaking the test suite of Automotion.

```

1 private static Class<?>
2   detectClass(String str) {
3   try {
4     Integer.valueOf(str.trim());
5     return Integer.class;
6   } catch (Exception ex) {}
7   try {
8     Float.valueOf(str.trim());
9     return Float.class;
10  } catch (Exception ex) {}
11  try {
12    Double.valueOf(str.trim());
13    return Double.class;
14  } catch (Exception ex) {}
15  try {
16    new BigInteger(str.trim());
17    return BigInteger.class;
18  } catch (Exception ex) {}
19  try {
20    new BigDecimal(str.trim());
21    return BigDecimal.class;
22  } catch (Exception ex) {}
23  return String.class;
24 }

```

Listing 2. Method from `corn` detecting the correct Java type to represent a JSON literal

9. <https://github.com/ITArray/automotion-java>

CrashCoin¹⁰, a cryptocurrency implemented in Java, originally depends on `org.json`. CrashCoin’s test suite includes 15 test cases that cover parts of CrashCoin which invoke the API of `org.json`. For all the libraries in our reservoir, except `corn` and `mjson`, we successfully build CrashCoin with ARGO and all test cases pass, which generates 18 variants of the project with 18 different providers for JSON processing. CrashCoin’s test suite fail when substituting `org.json` by `corn`. `TestBlockchain#testBlockchainBlockAdding` fails with `corn` because this JSON library does not handle correctly natural numbers that do not fit in an `Integer` (number in the interval $2^{31} - 1$ to -2^{31}). When running the test, the JSON library needs to determine the type of 1,512,901,875,251. The library `corn` relies on the method `detectClass`, shown in Listing 2, to determine the Java type to represent a JSON literal. This method tries to parse the literal as `Integer`, if this fails, it tries to parse the literal as a `Float`, then as a `Double`, and so on. But parsing the String 1,512,901,875,251 with `Float#valueOf` does not raise an exception for values that do not fit on 32 bits. Instead, the method returns the rounded value 1.51290184E12, losing the last 5 digits of precision and failing the test.

Overall, the 2 libraries that pass the least clients’ test suite, `mjson` (120 out of 329) and `jjson` (135 out of 329) are also the two libraries that fail the most tests in our cross testing experiments as shown in Table 5. This confirms the intuition given in RQ1, that these two libraries exhibit a behavior that is more different from the 4 bridged libraries than the other libraries, hence their use as substitution libraries is less likely to succeed.

Answer to RQ4. ARGO successfully diversifies the JSON supply chain of 272 of the 329 (83%) client applications. 195 of them are compatible with 15 or more libraries. In total, from 329 clients, we synthesize 4,069 variant applications using diverse JSON suppliers. This is an empirical assessment of the supply chain diversity that can be achieved by the Library Substitution Framework proposed in this work.

5.5 RQ5. How can clients increase the diversity of their providers?

In this research question, we analyze the root cause of test failures when testing the clients with ARGO. A key observation is that some test failures occur because of a tight coupling between the client and the JSON library. Some coupling is accidental and can be avoided to eventually make the client more prone to supply chain diversification. In this section, we discuss and illustrate three principles that enable more diversification. While the examples are collected from our experiments on JSON library substitution, we draw from them generic principles that are not specific to JSON libraries.

¹ `CorpusMetadata (Map<String, Object> data) {`

¹⁰ <https://github.com/StanIsAdmin/CrashCoin>

```
2 corpusName = (String) data.get(CORPUS_NAME);
3 applyStemmer = (long) data.get(APPLY_STEMMER);
4 [...]
5 }
```

Listing 3. Excerpt of `CorpusMetadata` constructor, from `Lambda-3/Indra`

Minimize reliance on implicit library behavior: Some undocumented behaviors of a library, that are more linked to its implementation than to the contract of its API, are used by some clients. Listing 3 shows such an example of dependence over an observed behavior rather than a contractual one. `CorpusMetadata` is class from `Indra`¹¹, which depends on `json-simple`. The constructor of this class takes a `Map` as an argument. In practice, this `Map` is read from a JSON object parsed with `json-simple`. This constructor assumes that specific types correspond to each key. In particular, the entry retrieved for the key `APPLY_STEMMER` is assumed to be typed as a `long`. While this does not cause any issue with numbers read by `json-simple`, other JSON libraries may encode them with a different Java type. For example, `fastjson` encodes some value with `Integer`. Hence, when ARGO substitutes `json-simple` with `fastjson`, the cast operations fail and a `ClassCastException` is thrown. This illustrates a case of a client that relies on an undocumented behavior of a library (returning a `Long` for natural numbers) rather than the one guaranteed by the API (returning an `Object`). Limiting coupling to return types that are not guaranteed by the signature of an API element is a sound design principle that facilitates dependency substitution and diversification.

```
1 private void runTest(String wkt,
2   int srid, boolean encodeCRS,
3   String expectedGeojson)
4   throws ParseException {
5   Geometry geom = read(wkt);
6   geom.setSRID(srid);
7   geoJsonWriter.setEncodeCRS(encodeCRS);
8   String json = geoJsonWriter.write(geom);
9   json = json.replace("'", "\'");
10  assertEquals(json, expectedGeojson);
11 }
```

Listing 4. Test excerpt from `jts GeoJsonWriterTest`

Test cases should not over specify the behavior of the client: Listing 4 shows an example of a test that over specifies the behavior of the program under test. It is extracted from the test suite of `jts`¹². It checks that the class `Geometry` is correctly serialized in JSON. However, instead of checking that the information is indeed contained in a well-formed JSON string, the test checks that the serialized string is exactly equal to an expected value, character per character. This is over specification of the expected behavior, since the JSON standard specifies that the order of key-value pairs is not meaningful. In this case, 16 out of 20 ARGO libraries make this test fail while they still produce an equivalent JSON string, which is not strictly equal. The other 4 libraries pass the test. Over-specifying tests hinders library substitution, by erroneously indicating to the developer of the client that a library is incompatible.

¹¹ <https://github.com/Lambda-3/Indra>

¹² <https://github.com/locationtech/jts>

```

1 @Test
2 public void testValueValidation()
3     throws SubdocException {
4     assertBadDictValue("INVALID");
5     assertBadDictValue("1,2,3,4");
6     assertBadDictValue("1,\"k2\":2");
7     assertBadDictValue("{ \"foo\" }");
8     assertBadDictValue("{ \"foo\": }");
9     assertBadDictValue("nul");
10    assertBadDictValue("2.0.0");
11    assertBadDictValue("2.");
12    assertBadDictValue("2.0e");
13    assertBadDictValue("2.0e+");
14 }

```

Listing 5. Test excerpt from CouchbaseMock testValueValidation

Limit dependency on behavior stricter than the standard: Listing 5 shows an excerpt of a test for CouchbaseMock¹³. It checks that specific values cannot be inserted in a JSON object. RFC 8259 [40], that standardizes the JSON format, stipulates that JSON libraries should not generate such values when they produce JSON text, but that they are free to accept them or not when reading JSON text. This test from CouchbaseMock verifies that such values are rejected. This means that CouchbaseMock is stricter than the JSON standard. CouchbaseMock depends on `json-simple`, which rejects these ill-formed values. Yet, other libraries often accept these values [26], without violating RFC 8259 [40]. Hence, when `json-simple` is substituted by another JSON library, the test may fail. In our dataset, 11 of the 20 libraries make this test fail, while the other 9 make it pass. We showed in our previous work [26] that there exists a large diversity of behavior among JSON libraries when parsing ill-formed. This diversity emerges because the behavior of JSON libraries is not standardized for ill-formed values. It is a sound design principle for client applications to limit their assumptions about nonstandard API behavior, which can favor automatic dependency diversification.

Answer to RQ5. A manual analysis of corner cases, reveals three design principles can favor dependency diversification: (i) Clients should not depend on implicit behavior of the library; (ii) test cases should not over-specify the behavior of the client they test; (iii) clients should limit their assumptions about non-standard behavior.

6 THREATS TO VALIDITY

Internal Validity. We evaluate the concept of Library Substitution Framework with a concrete implementation for the Java JSON reservoir. We rely on application test suites as an oracle for successful substitution. However, test suites are imperfect. To limit the impact of this threat to validity, we rely on a two stages process. ARGO is tested with carefully curated test suites of the 4 bridged libraries. We systematically remove libraries which test suite passes with the PLACEBO wrapper. This ensures that the tests cover the JSON library and that its behavior is actually depended on.

External Validity. We evaluate the concept of Library Substitution Framework in the single context of JSON libraries. This opens a discussion on how does this concept

apply to other domains. We foresee three key arguments in favor of such an approach for other domains. Reservoirs of similar libraries exist in several domains, as evidenced by browsing software repositories for libraries of a specific domain¹⁴. Previous work has demonstrated the possibility of performing wrapper based migration for Swing and SWT libraries [41], XML [12] or user interfaces [42]. The overall architecture that we propose in this work is inspired by the one of the framework Simple Logging Facade for Java [43]. Even if the architecture of `slf4j` does not aim at the same goals, it shows that such an architecture is possible in the domain of logging libraries.

7 RELATED WORK

Our work about diversification in the software supply chain relates to three research areas: automatic synthesis of software diversity, library management and software supply chain hardening.

7.1 Automated Diversity

Automatic diversification was pioneered by the seminal work of Cohen [11] and Forrest [10]. They proposed to generate program variants that deliver the same functionality as the original, while exhibiting differences in the way they handle unspecified behavior. Following these initial work, subsequent studies analyzed different kinds of transformations in the stack [44], on binary code [45], [46], at the binary interface level [47], in the compiler [48] or in the source code [49], [50]. All these transformations operate on a small scope, typically at the instruction-level. This is both a necessity to limit the risks of breaking the original functionality, and a key limitation to achieve behavior diversity outside the specified requirements. Meanwhile, only few techniques propose to exploit the existence of alternative libraries to create diversity. Persaud and al. [51] present FrankenSSL. This approach recombines fragments of forks of OpenSSL to create library variants that all provide the same features. But these fork have a very similar API as they descend from a unique project. Our proposal for a Library Substitution Framework generalizes the idea of exploiting the natural diversity of library implementations, at build time.

The natural emergence of functionally diverse implementations of the same features has been harnessed in several ways in the past, to reduce common failure [52]. For example, collection libraries exist in many different implementations, which can be selected according to application specific performance requirements, either statically [53] or dynamically [16], [53]. We have previously harnessed the natural diversity of Java decompilers to improve the overall precision of decompilation [54]. Gashi and colleagues have tamed the diversity of SQL servers for security purposes [55], while Xu and Kim leveraged the execution platform diversity to protect against attacks on PDF applications [56]. The concept of Library Substitution Framework is founded on the natural emergence of diverse implementations of various kinds of libraries. Our concrete implementation, ARGO, harnesses JSON libraries that differ in performance [57] as well as in behavior [26]. This type of diversity in the supply

13. <https://github.com/couchbase/CouchbaseMock>

14. <https://mvnrepository.com/open-source>

chain of applications is beneficial to protect against a single point of failure.

7.2 Library Migration

Techniques to help developers in the migration process usually suggest mappings between specific API elements providing similar features. Chen et al. [58] describe an unsupervised learning approach to create a database of similar APIs. Alrubby and colleagues [59], [25] present a tool named MigrationMiner that finds migration rules, in past migrations of other projects. These rules help developers to replace calls to the previous API by their equivalent in the new API. Fazzini and colleagues [60] propose APIMigrator, to automate the migration of applications when the Android API evolves, based on how other projects have already migrated. These tools assist developers in their migration process, and do not automate the migration of applications. They could assist the developers of a Library Substitution Framework in the development of bridges.

In his thesis, Bartolomei [42] proposes design principles for wrapper-based migration. Sharma and colleagues [61] wrote a tool that synthesizes adapters to replace functions that provide similar features, one by another, inside a given project. Previous projects `slf4j` [43] or `micrometer` [62] implement such a family of adapters for reservoirs of logging and metric libraries. They aim at merging respectively logs and metric gathered by the different libraries present in the dependency tree of an application. In this work, we propose a generic architecture for library substitution, which rely on a similar architecture for a different purpose. Our goal here is to build variants of applications, depending on different library suppliers.

7.3 Supply Chain Hardening

Recent work has highlighted the need for software supply-chain hardening, with a focus on software dependencies [63]. One approach consists in systematically building dependencies from source code and ensuring a strictly deterministic build [64]. Deterministic builds are important as discrepancies between sources and packages can hide malicious code from the eyes of reviewers of open-source software [65]. But making builds fully deterministic is currently challenging because of timestamping or random naming [66]. Nikitin and colleagues propose a decentralized software-update framework to distribute software packages for which the build is reproducible [67].

Other works aim at defending against malicious libraries also exists. Pashchenko and colleagues [68] propose a methodology to evaluate which dependencies of a software project are vulnerable. Vasilakis and colleagues [69] propose a technique that learns the normal behavior of a dependency and automatically synthesizes a new library that exhibits an equivalent client-observable behavior, with no vulnerability. Catuogno and colleagues propose a technique to prevent malicious users from forcing applications to install vulnerable dependencies [70].

Cox [2] suggests that developers of client applications should decouple their code from the concrete implementation of libraries, adding an abstraction layer between the application and the API. This recommended abstraction layer

regroups all calls to the external API in a localized wrapper, making future migrations simpler. We propose to mutualize this solution to all clients of a library reservoir. Our notions of bridge and facade for a library reservoir detach the APIs of these libraries from their actual implementation, allowing for library substitution.

8 CONCLUSION

In the context of ever-increasing reliance on external software libraries, supply chain attacks represent a major threat. To mitigate their scale, we propose to generate and deploy software variants with a diverse supply chain.

In this work, we present the concept of Library Substitution Framework based on a three-tier adaptation architecture. It allows developers to substitute a library by an alternative one, without modifications of the client software, enabling diversified variants based on each different library alternative. To assess the validity of the architecture we propose, we implement a concrete framework for Java JSON libraries. Our framework, ARGO, supports 20 different JSON libraries. We test this framework by reusing the test suites of bridged libraries. We evaluate the ability of our framework to diversify the supply chain of applications on a dataset of open-source project depending on JSON libraries. On 195 of the 368 java applications tested, we are able to provide at least 15 alternatives.

These results open the way for usages of the variants produced by our approach such as Moving Target Defense, or N-Variant systems.

REFERENCES

- [1] A. Decan, T. Mens, and P. Grosjean, "An empirical comparison of dependency network evolution in seven software packaging ecosystems," *Empir. Softw. Eng.*, vol. 24, no. 1, pp. 381–416, 2019.
- [2] R. Cox, "Surviving Software Dependencies," *Communications of the ACM*, vol. 62, no. 9, pp. 36–43, 2019.
- [3] H. Mack and T. Schroer, "Security midlife crisis: Building security in a new world," *IEEE Security & Privacy*, vol. 18, no. 4, pp. 72–74, 2020.
- [4] M. Carvalho, J. DeMott, R. Ford, and D. A. Wheeler, "Heartbleed 101," *IEEE Security & Privacy*, vol. 12, no. 4, pp. 63–67, 2014.
- [5] Nathan Willis, "A single Node of failure." <https://lwn.net/Articles/681410/>. Accessed: 2021-07-07.
- [6] M. Ohm, H. Plate, A. Sykosch, and M. Meier, "Backstabber's knife collection: A review of open source software supply chain attacks," in *Proc. of DIMVA*, pp. 23–43, 2020.
- [7] M. Taylor, R. Vaidya, D. Davidson, L. De Carli, and V. Rastogi, "Defending against package typosquatting," in *Proc. of the Int. Conf. on Network & System Security*, pp. 112–131, 2020.
- [8] F. Massacci, T. Jaeger, and S. Peisert, "Solarwinds and the challenges of patching: Can we ever stop dancing with the devil?," *IEEE security & privacy*, vol. 19, no. 2, pp. 14–19, 2021.
- [9] Thomas Hunter II, "Compromised npm Package: event-stream." <https://medium.com/intrinsic-blog/compromised-npm-package-event-stream-d47d08605502>. Accessed: 2021-07-07.
- [10] S. Forrest, A. Somayaji, and D. H. Ackley, "Building diverse computer systems," in *Proc. HotOS*, pp. 67–72, 1997.
- [11] F. B. Cohen, "Operating system protection through program evolution," *Computers & Security*, vol. 12, no. 6, pp. 565–584, 1993.
- [12] T. T. Bartolomei, K. Czarnecki, R. Lämmel, and T. Van Der Storm, "Study of an api migration for two xml apis," in *Proc. of SLE*, pp. 42–61, 2009.
- [13] E. Levy, "Poisoning the software supply chain," *IEEE Security & Privacy*, vol. 1, no. 3, pp. 70–73, 2003.
- [14] K. Thompson, "Reflections on trusting trust," *Communications of the ACM*, vol. 27, no. 8, 1984.

- [15] P. Koopman and J. DeVale, "Comparing the robustness of posix operating systems," in *Digest of Papers. Twenty-Ninth Annual International Symposium on Fault-Tolerant Computing*, pp. 30–37, 1999.
- [16] O. Shacham, M. Vechev, and E. Yahav, "Chameleon: adaptive selection of collections," in *Proc. of PLDI*, pp. 408–418, 2009.
- [17] D. Sondhi, M. Jobanputra, D. Rani, S. Purandare, S. Sharma, and R. Purandare, "Mining similar methods for test adaptation," *IEEE Transactions on Software Engineering*, 2021.
- [18] P. Louridas, D. Spinellis, and V. Vlachos, "Power laws in software," *ACM Transactions on Software Engineering and Methodology*, vol. 18, no. 1, pp. 1–26, 2008.
- [19] A. Zerouali and T. Mens, "Analyzing the evolution of testing library usage in open source java projects," in *Proc. of SANER*, pp. 417–421, 2017.
- [20] K. P. Birman and F. B. Schneider, "The monoculture risk put into context," *IEEE Security & Privacy*, vol. 7, no. 1, pp. 14–17, 2009.
- [21] G. Goth, "Addressing the monoculture," *IEEE Security & Privacy*, vol. 1, no. 6, pp. 8–10, 2003.
- [22] Java Community Process, "JSRs: Java Specification Request." <https://jcp.org/en/jsr/overview>. Accessed: 2021-07-07.
- [23] H. Alrubaye, M. W. Mkaouer, and A. Ouni, "Migrationminer: An automated detection tool of third-party java library migration at the method level," in *Proc. of ICSME*, pp. 414–417, 2019.
- [24] I. Balaban, F. Tip, and R. Fuhrer, "Refactoring support for class library migration," *ACM SIGPLAN Notices*, vol. 40, no. 10, pp. 265–279, 2005.
- [25] H. Alrubaye and M. W. Mkaouer, "Automating the detection of third-party java library migration at the function level," in *Proc. of CASCON*, p. 60–71, 2018.
- [26] N. Harrand, T. Durieux, D. Broman, and B. Baudry, "The behavioral diversity of java json libraries," in *Proc. of ISSRE*, 2021.
- [27] C. Soto-Valero, A. Benelallam, N. Harrand, O. Barais, and B. Baudry, "The emergence of software diversity in maven central," in *Proc. of MSR*, pp. 333–343, 2019.
- [28] N. Harrand, A. Benelallam, C. Soto-Valero, F. Bettega, O. Barais, and B. Baudry, "Api beauty is in the eye of the clients: 2.2 million maven dependencies reveal the spectrum of client-api usages," *Journal of System and Software*, 2021.
- [29] L. Ochoa, T. Degueule, J.-R. Falleri, and J. Vinju, "Breaking bad? semantic versioning and impact of breaking changes in maven central," *Empirical Software Engineering*, 2021.
- [30] S. Sobernig and U. Zdun, "Inversion-of-control layer," in *Proc. of EuroPLoP*, 2010.
- [31] W. Tan, Y. Fan, A. Ghoneim, M. A. Hossain, and S. Dustdar, "From the service-oriented architecture to the web api economy," *IEEE Internet Computing*, vol. 20, no. 4, pp. 64–68, 2016.
- [32] K. J. Millman, F. Pérez, V. Stodden, F. Leisch, and R. D. Peng, "Developing open-source scientific practice," *Implementing Reproducible Research*, vol. 149, 2014.
- [33] Z. H. Liu, B. C. Hammerschmidt, D. McMahon, H. J. Chang, Y. Lu, J. Spiegel, A. C. Sosa, S. Suresh, G. Arora, and V. Arora, "Native JSON datatype support: Maturing SQL and nosql convergence in oracle database," *Proc. VLDB Endow.*, vol. 13, no. 12, pp. 3059–3071, 2020.
- [34] t0st, "How I cut GTA online loading times by 70%," 2021.
- [35] O. Peles and R. Hay, "One class to rule them all: 0-day deserialization vulnerabilities in android," in *Proc. of WOOT 15*, 2015.
- [36] J. Viega, G. McGraw, T. Mutdosch, and E. W. Felten, "Statically scanning java code: Finding security vulnerabilities," *IEEE Software*, vol. 17, no. 5, pp. 68–74, 2000.
- [37] S. F. Fingann, "Java deserialization vulnerabilities," in *Master thesis*, University of Oslo Association, Sept. 2020.
- [38] Alvaro Muñoz, Oleksandr Mirosh, "Friday the 13th: JSON Attacks." <https://www.blackhat.com/docs/us-17/thursday/us-17-Munoz-Friday-The-13th-Json-Attacks.pdf>. Accessed: 2021-07-07.
- [39] MIRTRE, "CVE affecting jackson-databind." <https://cve.mitre.org/cgi-bin/cvekey.cgi?keyword=jackson-databind>. Accessed: 2021-07-07.
- [40] T. Bray, "The JavaScript Object Notation (JSON) Data Interchange Format," RFC 8259, RFC Editor, December 2017.
- [41] T. T. Bartolomei, K. Czarnecki, and R. Lämmel, "Swing to swt and back: Patterns for api migration by wrapping," in *Proc. of ICSME*, pp. 1–10, 2010.
- [42] T. Tonelli Bartolomei, *Migration of Applications across Object-Oriented APIs*. PhD thesis, University of Waterloo, 2012.
- [43] C. Gülcü, "Simple logging facade for java (slf4j)," 2006.
- [44] S. Lee, H. Kang, J. Jang, and B. B. Kang, "Savior: Thwarting stack-based memory safety violations by randomizing stack layout," *IEEE Transactions on Dependable and Secure Computing*, 2021.
- [45] R. Wartell, V. Mohan, K. W. Hamlen, and Z. Lin, "Binary stirring: Self-randomizing instruction addresses of legacy x86 binary code," in *Proc. of CCS*, pp. 157–168, 2012.
- [46] B. Abrath, B. Coppens, M. Mishra, J. V. den Broeck, and B. D. Sutter, "Breakpad: Diversified binary crash reporting," *IEEE Transactions on Dependable Secure Computing*, vol. 17, no. 4, pp. 841–856, 2020.
- [47] G. S. Kc, A. D. Keromytis, and V. Prevelakis, "Countering code-injection attacks with instruction-set randomization," in *Proc. of CCS*, pp. 272–280, 2003.
- [48] A. Homescu, T. Jackson, S. Crane, S. Brunthaler, P. Larsen, and M. Franz, "Large-scale automated software diversity—program evolution redux," *IEEE Transactions on Dependable and Secure Computing*, vol. 14, no. 2, pp. 158–171, 2017.
- [49] B. Baudry, S. Allier, and M. Monperrus, "Tailored source code transformations to synthesize computationally diverse program variants," in *Proc. of ISSTA*, pp. 149–159, 2014.
- [50] N. Harrand, S. Allier, M. Rodriguez-Cancio, M. Monperrus, and B. Baudry, "A journey among java neutral program variants," *Genetic Programming and Evolvable Machines*, vol. 20, no. 4, pp. 531–580, 2019.
- [51] B. Persaud, B. Obada-Obieh, N. Mansourzadeh, A. Moni, and A. Somayaji, "Frankenssl: Recombining cryptographic libraries for software diversity," in *Proc. of the Annual Symposium On Information Assurance*, pp. 19–25, 2016.
- [52] K. Salako and L. Strigini, "When does "diversity" in development reduce common failures? insights from probabilistic modeling," *IEEE Transactions Dependable Secure Computing*, vol. 11, no. 2, pp. 193–206, 2014.
- [53] M. Basios, L. Li, F. Wu, L. Kanthan, and E. T. Barr, "Darwinian data structure selection," in *Proc. of ESEC/FSE*, pp. 118–128, 2018.
- [54] N. Harrand, C. Soto-Valero, M. Monperrus, and B. Baudry, "Java decompiler diversity and its application to meta-decompilation," *J. Syst. Softw.*, vol. 168, p. 110645, 2020.
- [55] I. Gashi, P. T. Popov, and L. Strigini, "Fault tolerance via diversity for off-the-shelf products: A study with SQL database servers," *IEEE Transactions Dependable Secure Computing*, vol. 4, no. 4, pp. 280–294, 2007.
- [56] M. Xu and T. Kim, "Platpal: Detecting malicious documents with platform diversity," in *Proc. of USENIX Security*, pp. 271–287, 2017.
- [57] K. Maeda, "Performance evaluation of object serialization libraries in xml, json and binary formats," in *Proc. of DICTAP*, pp. 177–182, 2012.
- [58] C. Chen, Z. Xing, Y. Liu, and K. O. L. Xiong, "Mining likely analogical apis across third-party libraries via large-scale unsupervised api semantics embedding," *IEEE Transactions on Software Engineering*, vol. 47, no. 3, pp. 432–447, 2021.
- [59] H. Alrubaye, M. W. Mkaouer, and A. Ouni, "On the use of information retrieval to automate the detection of third-party java library migration at the method level," in *Proc. of ICPC*, pp. 347–357, 2019.
- [60] M. Fazzini, Q. Xin, and A. Orso, "Apimigrator: An api-usage migration tool for android apps," in *Proc. of MOBILESoft*, p. 77–80, 2020.
- [61] V. Sharma, K. Hietala, and S. McCamant, "Finding substitutable binary code by synthesizing adapters," *IEEE Transactions on Software Engineering*, vol. 47, no. 8, pp. 1626–1643, 2021.
- [62] "Micrometer," 2021.
- [63] S. Peisert, B. Schneider, H. Okhravi, F. Massacci, T. Benz, C. Landwehr, M. Mannan, J. Mirkovic, A. Prakash, and J. B. Michael, "Perspectives on the solarwinds incident," *IEEE Security & Privacy*, vol. 19, no. 2, pp. 7–13, 2021.
- [64] C. Lamb and S. Zacchiroli, "Reproducible builds: Increasing the integrity of software supply chains," *IEEE Software*, 2021.
- [65] D.-L. Vu, F. Massacci, H. Plate, and A. Sabetta, "Lastpymile: Identifying the discrepancy between sources and packages," in *Proc. of ESEC/FSE*, 2021.
- [66] Z. Ren, H. Jiang, J. Xuan, and Z. Yang, "Automated localization for unreproducible builds," in *Proc. of ICSE*, pp. 71–81, 2018.
- [67] K. Nikitin, E. Kokoris-Kogias, P. Jovanovic, N. Gailly, L. Gasser, I. Khoffi, J. Cappos, and B. Ford, "CHAINIAC: Proactive software-update transparency via collectively signed skipchains and verified builds," in *Proc. of USENIX Security*, pp. 1271–1287, 2017.

- [68] I. Pashchenko, H. Plate, S. E. Ponta, A. Sabetta, and F. Massacci, "Vuln4real: A methodology for counting actually vulnerable dependencies," *IEEE Transactions on Software Engineering*, 2020.
- [69] N. Vasilakis, A. Benetopoulos, S. Handa, A. Schoen, J. Shen, and M. C. Rinard, "Supply-chain vulnerability elimination via active learning and regeneration," in *Proc. of CCS*, vol. 16, 2021.
- [70] L. Catuogno, C. Galdi, and G. Persiano, "Secure dependency enforcement in package management systems," *IEEE Transactions on Dependable Secure Computing*, vol. 17, no. 2, pp. 377–390, 2020.