

# A Comprehensive Survey of Logging in Software: From Logging Statements Automation to Log Mining and Analysis

Sina Gholamian, *Student Member, IEEE*, Paul A. S. Ward, *Member, IEEE*

**Abstract**—Logs are widely used to record runtime information of software systems, such as the timestamp and the importance of an event, the unique ID of the source of the log, and a part of the state of a task’s execution. The rich information of logs enables system developers (and operators) to monitor the runtime behaviors of their systems and further track down system problems and perform analysis on log data in production settings. However, the prior research on utilizing logs is scattered and that limits the ability of new researchers in this field to quickly get to the speed and hampers currently active researchers to advance this field further. Therefore, this paper surveys and provides a systematic literature review and mapping of the contemporary logging practices and log statements’ mining and monitoring techniques and their applications such as in system failure detection and diagnosis. We study a large number of conference and journal papers that appeared on top-level peer-reviewed venues. Additionally, we draw high-level trends of ongoing research and categorize publications into subdivisions. In the end, and based on our holistic observations during this survey, we provide a set of challenges and opportunities that will lead the researchers in academia and industry in moving the field forward.

**Index Terms**—survey, systematic literature review (SLR), systematic mapping (SM), software systems, logging, log statement, log file, log automation, log analysis, log mining, logging cost, anomaly detection, failure detection and diagnosis.



## 1 INTRODUCTION

SOFTWARE systems are pervasive and play important and often critical roles in the society and economy such as in airplanes or surgery room patient monitoring systems. Gathering feedback about software systems’ states is a non-trivial task and plays a crucial role in system diagnosis in the case of a failure. In the interest of higher availability and reliability, software systems regularly generate *log files* of their status and runtime information. Developers insert logging statements into the source code which are then printed in the log files, also known as *execution logs* and *event logs* [1]. Then, at a later time, while the system is running or post-mortem, developers or operators would analyze the log files for various tasks. For example, the content of log files has been studied to achieve a variety of goals such as anomaly and fault detection [2], [3], [4], [5], online or postmortem performance and failure diagnosis [6], [7], [8], [9], [10], pattern detection [11], [12], [13], profile building [13], business decision making [14], and user’s behavior observation [15].

Conventionally, software developers and practitioners apply testing and monitoring techniques to analyze the software systems. System testing happens during the development phase by developers, while practitioners utilize system monitoring techniques to understand the behavior of the system in the deployed environment [16]. As such, it is a common practice to have running programs report on their internal state and variables, through log files that

system administrators and operators can analyze [17] for different purposes. This continuous cycle of development and deployment of the software and looking at the system logs has also initiated and thrived adjacent fields of research such as DevOps [18], [19], [20]. That is, the importance of log analysis and its computational intensity has also brought in other tools to scale up the effort. For example, considering the advancements of machine learning (ML) and artificial intelligence (AI) and the vast size of the log files, research has proposed the use of ML for automated operation analysis (AIOps) [21] of execution logs. From the commercialization perspective, the widespread need for log analysis has also contributed to the emergence of commercial products such as Splunk [22] and Elastic Stack [23]. Splunk makes the large-scale logs accessible by extracting patterns and correlating system metrics to diagnosing problems and provide insight for business decisions. Elastic Stack [23], a.k.a. ELK, consists of three different subsystems of Elasticsearch [24], Logstash [25], and Kibana [26], works to ingest and process logs from different sources by Logstash, in a searchable format accomplished by Elasticsearch, and Kibana lets users visualize data with charts and graphs.

From the system’s diagnosis perspective, the information provided through the logging statements combined with other system metrics, such as CPU, memory, and I/O utilization, serves an important role in anomaly detection and understanding and diagnosing the system’s runtime behavior in the case of a failure. Despite the tremendous potential value hidden in execution logs, the inherent characteristics of logs, such as their heterogeneity and voluminosity [16], make the analysis of them difficult on a large scale and poses several challenges. Some of the associated challenges with logging statements and their analysis in software systems

- S. Gholamian and P. Ward are with University of Waterloo, Waterloo, Canada, N2L 3G1.

E-mail: {sgholamian, pasward}@uwaterloo.ca

are as follows:

- ① Providing proper logging statements inside the source code remains a manual, *ad-hoc*, and non-trivial task in many cases [27] due to the free-form text format of log statements and lack of a general guideline for logging.
- ② As the size of computer systems increases and software becomes more complex and distributed, manual inspection of log files becomes cumbersome and impractical, and it calls for automated analysis of logs.
- ③ Log data can be heterogeneous and voluminous, as within a large software system multiple subsystems may potentially generate a plethora of logs in different formats. Additionally, logging inefficiently introduces overhead on multiple subsystems such as I/O, network, and storage.
- ④ Developers and automatic logging analysis tools that aim to automate the logging process always face challenging questions of “*what, where, how, and whether to log?*”.

Considering the aforementioned challenges, prior and ongoing research has made numerous efforts to mine and understand log statements in the source code and execution log files to either gain more insights about logging practices, troubleshoot the software, or automate the logging process [28], [29], [30]. Figure 1 depicts a framework in which the creation process and analysis of log files are illustrated. After the system’s architecture is decided and programmers implement the source code with logging statements, the operators run the system by selecting proper runtime configuration parameters (e.g., logging verbosity level in Log4j [31]). While the software is running, events that are logged in the source code generate records within the log files. Next, administrators (, practitioners), and automated log analyzer tools may review the files and feedback the outcome to the designers, programmers, and operators to make adjustments to the architecture, source code, and system configuration if needed, respectively.

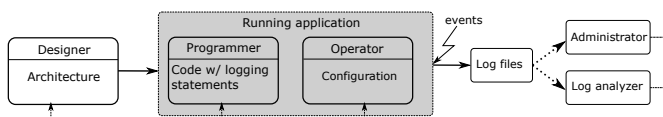

Fig. 1: Framework for creation and analysis of log files [32].

As the size of computer systems increases, the manual process of developers placing logging statements into the source code and administrators reviewing the log files and detecting problems negatively affecting the system becomes less practical and less effective. Consequently, being able to automatically detect logging points and insert appropriate logging statements in the source code, as well as systematically detecting system issues are very beneficial and high-in-demand research topics [30], [33]. Thus, researchers have dedicated a significant amount of studies in the area of software logging and log analysis techniques throughout the last decade [16] to propose various approaches, including automated analysis and application of machine learning to process large-scale log files. However, after reviewing the prior work, we noticed what has not been addressed is a clear review of the current progress in software systems’ logging and log analysis research. It is, therefore, hard for

researchers to recognize how their current and future work will fit in the big picture of present-day logging research. Understanding where we are at the moment and creating a snapshot of the current research is a fundamental step towards understanding where we should go from here and what the necessary next steps of the research would be. Learning from our own experiences and the obstacles that we have to go through to holistically picturize the current research in the field, this survey aims to pave the road obstacles and provide a methodological review of logging, its practices, and its automation techniques and tools for software systems. Additionally, in this survey, we review the current state of logging in software to discover solutions for the aforementioned challenges and highlight the next steps for future research efforts. We review and study a vast number of peer-reviewed conference and journal papers from related research areas including software and distributed systems, dependability, and machine learning. Moreover, we aim to build knowledge [34] and trends by connecting and combining findings from multiple research. Thus, we examine and categorize the prior research for *logging costs*, *logging practices*, *automation of log analysis*, and *efforts to automate the insertion and improvement of logging statements inside the source code*. Finally, we provide *trends and opportunities for future work* based on the insights we gain during this survey. For each research, we provide its 1) *aim*, i.e., the problem it is trying to address, 2) *experimentation*, 3) *results and findings*, 4) *advantages*, i.e., *pros*, and 5) *disadvantages*, i.e., *cons*. Before we dive deeper into the survey, we will review a few important vocabulary in the following.

## 1.1 Terminology

**Log printing statement (LPS).** LPSs are the log statements in the source code added by developers. We use “*log printing statement*”, “*log statement*”, and “*logging statement*” interchangeably, as the prior work has used all of the variations [4], [33], [35], [36], [37].

**Log message.** A log message, typically a single line, is the output of the LPS in the log file. Prior work also makes a subtle distinction between a log message and a **log entry**, and defines a “*log entry*” or a “*log record*” as a line in the log file composed of a log header and a log message [188]. Log header contains timestamp, verbosity level, and source component, and its format is usually defined by the logging framework, e.g., *log appenders* [180], whereas a log message is written by the developer and consists of the amalgamation of the static part of the log message from the source code and the dynamic value of the variables during the runtime. For our purpose in this survey, log message, log entry, log record, and log event are used interchangeably [37], [38], [39], [40].

**Log file.** Log file(s) is a collection of log messages stored on a storage medium, also called “*logs*”, “*event logs*”, “*execution logs*”, or simply just “*log*” [4], [39], [40].

Additionally, we might refer to computer (computing) systems and software systems interchangeably in some occasions throughout this survey with regards to logs, meaning that the log messages in the log files are generated from log printing statements within the source code of the software systems (for various software or hardware related

events, concerns, or issues), which are also an artifact of computer systems as an umbrella for software, hardware, and anything in between.

## 1.2 Research Questions

While we review the prior literature, we aim to pursue and answer the following research questions:

- **RQ1:** How to systematically review and categorize prior logging research into different topics?
- **RQ2:** What are the publication trends based on venues, topics, and years?
- **RQ3:** How the research in each topic can be systematically compared with their *approaches, pros, and cons*?
- **RQ4:** What open problems and future directions are foreseeable for logging research?

With the pursuit of the aforementioned RQs, we ensure to follow the established evidence-based software engineering (EBSE) [41], [42] paradigm for our literature review. As a contributing improvement, our survey combines and benefits from the advantages of both systematic literature review (SLR) and systematic mapping (SM) paradigms. Prior research indicates the main differences between SM and SLR are that SM methodology is broader and more based on qualitative measures, while SLR focuses on narrower research questions and quantitative measures [43]. While being comprehensive, *i.e.*, SM, our survey also provides details on the experimentation and results of each primary study, *i.e.*, SLR. In summary, RQ1, RQ3, and RQ4 qualitatively assess the prior literature into different research categories base on different topics, *i.e.*, systematic mapping (SM) [44], whereas RQ2 quantitatively measures the publications based on venues, topics, and years, and RQ3 provides details aligned with SLR data extraction methods for each study, *e.g.*, *the aim, experiments, results, and findings* [43].

## 1.3 Survey Organization

The rest of this survey is organized as follows. Section 2, prior to answering the RQs, we provide the background for log statements, messages, and files. In Section 3, we provide our findings for RQ1 and categorize the prior logging research. In Section 4, we present our findings for RQ2 and present the publication trends for different topics, years, and venues. Then, Section 5 reviews the prior research in each category of logging in details and provide our findings for RQ3. In Section 6, we provide our findings for RQ4 and describe open problems and opportunities for future work, and Section 7 concludes the survey.

## 2 LOG STATEMENTS AND LOG FILES

Logging is the act of keeping a log [45]. In software systems, log messages represent *events of interest* (to developers, practitioners, or end users) that happen during the software system’s execution and are recorded to log files. In the simplest case, log messages are written to a single log file. However, in a distributed system, there can be multiple log files in different formats. The focus of our survey is on this type of logs which are also called execution logs or event logs [46]. Event logs are the outcome of logging statements that software developers insert into the source code. Event

logging and log files are playing an increasingly important role in computer systems and network management [2], [16], [46], which we will review in the following sections.

## 2.1 Transaction Logs

It is also worth mentioning briefly the difference between the execution logs and transaction logs. A transaction log (also called journal) is a record file of the transactions between a system and the users of that system, or a data collection method that naturally captures the type, content, or time of transactions made by a user from interacting with the system. In a database server, a transaction log is a file in which the server stores a record of all the transactions performed on the database [47]. The transaction log is an important component of database servers and cryptocurrency protocols (*e.g.*, blockchain [48]) when it comes to recovery. If there is a system failure, transaction logs are used to revert the database back to a consistent state.

## 2.2 Log Example

Software developers utilize logging statements inside the source code to gain insight into the internal state of applications amid their execution. In the simplest form, logging statements are *print* statements utilized in different programming languages. In this case, the logging statement may contain a textual part indicating the context of the log, *i.e.*, the *description* of the log, a *variable* part providing contextual information about the event. Figure 2 shows an example of logging statements in C programming language.

```
printf("Cannot find BPService for bpid=%d", id);
      |                description                | variable
```

Fig. 2: Log example in C.

Logging statements may utilize logging libraries to improve the organization of the logged information. For example, in Java, libraries such as Log4j [31] and SLF4J [49] provide a higher degree of flexibility to the developers. Logging libraries, also called logging utilities (LU) [50] or logging libraries and utilities (LLUs), provide extra features, such as *log level*, which indicate the verbosity and the severity of the logging statement. Log levels help to better distinguish the importance of runtime events and control the number of logs collected on the storage device [51]. For example, less verbose levels, *i.e.*, *fatal*, *error*, and *warn*, are leveraged to alarm the user when a potential problem happens in the system, and more verbose levels such as *info*, *debug*, and *trace* are utilized to record more general system events and information or detailed debugging. In practice, *info* and more verbose levels are utilized during the software development phase by programmers, and *info* or less verbose levels are, by default, for the software deployment phase, as the end user observes. In case more insight about the internal state is needed, end users might enable more verbose logging. An example of a logging statement with library usage for *warn* verbosity level is shown in Figure 3.

Logging statements are generally saved in log files. Figure 4 shows ten lines of logs from Apache Spark [52] execution logs collected in our execution of *k-means* clustering

level	description	variable
log.warn	("Cannot find BPSERVICE for bpid=" + id);	

Fig. 3: Log example with Log4j library.

algorithm [53] on a standalone cluster. In real-world cases, a computing cloud system can generate millions of such log messages per minute [54]. For example, for an online store with millions of customers worldwide, it is common to generate tens of terabytes of logs in a single day [55], [56].

Log file example	
1	20/02/21 13:47:47 WARN NativeCodeLoader: Unable to load native-hadoop library for your platform... using builtin-java classes where applicable
2	20/02/21 13:47:47 INFO SparkContext: Running Spark version 2.4.4
3	20/02/21 13:47:48 INFO SparkContext: Submitted application: JavaKMeansExample
4	20/02/21 13:47:48 INFO SecurityManager: SecurityManager: authentication disabled; ui acls disabled; users with view permissions: Set(user); groups with view permissions: Set(); users with modify permissions: Set(user); groups with modify permissions: Set()
5	20/02/21 13:47:49 INFO StandaloneSchedulerBackend: Connected to Spark cluster with app ID app-20200221134749-0004
6	20/02/21 13:47:49 INFO StandaloneAppClient\$ClientEndpoint: Executor added: app-20200221134749-0004/0 on worker-20200220231425-192.168.210.13:34881 (192.168.210.13:34881) with 8 core(s)
7	20/02/21 13:47:50 INFO EventLoggingListener: Logging events to file:/tmp/spark-events/app-20200221134749-0004
8	20/02/21 13:47:51 INFO DAGScheduler: Submitting 933 missing tasks from ResultStage 0 (MapPartitionsRDD[5] at map at KMeans.scala:248) (first 15 tasks are for partitions Vector(0, 1, 2, 3, 4, 5, 6, 7, 8, 9, 10, 11, 12, 13, 14))
9	20/02/21 13:47:53 INFO CoarseGrainedSchedulerBackend\$DriverEndpoint: Registered executor NettyRpcEndpointRef(spark-client://Executor) (192.168.210.12:39482) with ID 3
10	20/02/21 14:03:58 INFO DAGScheduler: Job 12 finished: sum at KMeansModel.scala:105, took 13.099825 s

Fig. 4: A log file example from Apache Spark.

As observed in Figure 4, a major part of logging messages is unstructured text. Thus, in order to make log files useful and avoid the hassle of manually processing a plethora of log files, the first and foremost step of log processing is the automatic “parsing” of log messages, which transforms unstructured logs into structured events. Not to be confused with syntactic parsers in programming languages, which parses source code and confirm whether it follows the rules of the formal grammar, log parser, on the other hand, transforms unstructured raw log files into a sequence of structured events, to enable automated analysis of logs. We review the log parsing process later in Section 5.4.3.

### 2.3 Program Traces vs. Logs

The term log is often used to represent the way a program is used (such as security logs), while tracing (not to be confused with “trace” log level in logging libraries such as Log4j) is used to capture the temporal sequence of events during a particular execution of a program [57], in contrast to logs which are generally the consolidation of continuous execution of software systems. Tracing is typically performed by an external program/tool that instruments the runtime environment, such as network traffic traces, whereas logs are the direct output of logging statements’ execution inside the software. Moreover, while traces are typically structured data, logs are free-form and unstructured text. For example, a trace can contain the software execution paths, the events triggered during the execution, and the value of variables, which are used for debugging and program understanding. Stack traces are common examples

that are used for function call tree tracing during development and postmortem debugging. Some of the well-known tracing systems include Google’s Dapper [58], X-Trace [59], Microsoft’s MagPie [60], the *black-box* approach [61], and Casper [62].

### 3 RQ1: HOW THE PRIOR LOGGING RESEARCH CAN BE CATEGORIZED TO DIFFERENT TOPICS?

In this section, we provide our findings for the first research question by reviewing the available literature and categorizing the logging research into its topics (and subtopics), which enables us to explain the survey scope that follows next.

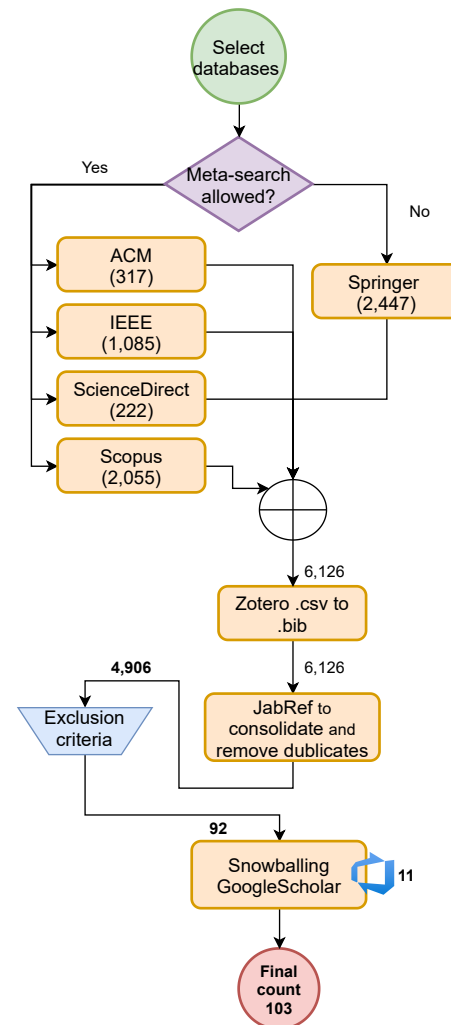

Fig. 5: This figure provides the steps involved in our survey methodology.

### 3.1 Survey Methodology

Studying log mining and logging analysis techniques in software systems is a challenging and widespread topic, and there have been numerous prior studies that focus on log analysis. Table 1 summarizes the databases and keywords used in our survey, and Figure 5 provides the flowchart of the steps in the database selection and reference analysis.

<b>Research databases</b>	ACM Digital Library, IEEE Xplore, ScienceDirect (Elsevier), Scopus, SpringerLink, and GoogleScholar (snowballing).
<b>Keywords</b>	'software AND log AND (statement OR file OR record OR event)' AND 'Publication Date: (01/01/2010 TO 05/31/2021)'

TABLE 1: Literature review databases and keywords. We searched in various online research databases for different combinations of log-related keywords.

We start with the established research databases listed in the table and search for the list of log-related keywords. If the database allows for metadata search (*i.e.*, title, abstract, and keywords), we limit our search to metadata, to avoid the inclusion of numerous unrelated research that has the keywords in their main text. However, for Springer, we could not use meta-search, and thus, the reason behind the high number of returned publications. We use reference management software, such as Zotero <sup>1</sup> and JabRef <sup>2</sup> to facilitate and automate our process of reference consolidation from different sources and duplicate removal. After duplicate removal, our process resulted in 4,906 papers.

For **exclusion criteria**, our focus has been on the full (*i.e.*, not short), recent papers in English in the last decade in the established venues, ranging from very good to flagship ones <sup>3</sup>. After the keyword search, we manually investigated the results and included relevant publications that directly tackle issues associated with log statements or log files, and excluded the ones which had a weak association with logs. Also, if a research project has multiple variations, *i.e.*, a conference paper followed by a more comprehensive journal paper, we only include the more comprehensive version. Additionally, once we find an influential (*i.e.*, highly-cited) paper, we also check all of its references and its citations, *i.e.*, *snowballing search* [63] with GoogleScholar. Followed by exclusion criteria, we are narrowed down to 92 publications, and at last, 11 additional references are added with snowballing, bringing the total count to 103 publications.

We categorize the selected publications (103) into **twelve categories** after carefully studying them. Our methodology for categorizing the publications has been based on a top-down approach. Meaning that, we first were able to draw categories that either focus on logging statements or the ones that focus on log files. We then further narrowed down each category based on its primary focus. Next, we also extracted subtopics for each paper, as usually, publications also partially cover some other related topics in their research. For example, Zhao *et al.* work [33] primarily focuses on log statement automation, but it also covers topics related to log cost analysis. The details for each category is available in Table 19 in Appendix A.

### 3.2 Survey Scope

Based on our methodology, the scope of our survey is developed as follows. To the best of our knowledge, there

is no prior work that provides a systematic and comprehensive coverage on log mining and automation techniques in software systems, covering different aspects of logging such as mining source code and log files, automating log printing statements in the source code, and their evaluation techniques. There are a few existing surveys on the application of execution logs for anomaly and problem detection [64], system monitoring [16], and instrumentation [65]. We cover the following sections in our survey:

- **Logs and log files.** We explain what are log files, log statements, and log messages, and what sort of applications and analyses they are leveraged for.
- **Logging cost.** We point out the quantitative and qualitative costs and benefits associate with logging.
- **Logging statement mining and automating.** Logging research aims to understand current logging practices and use the findings to improve the log printing statements with automatic log insertion and learning to log techniques. Thus, we review:
  - **Logging code practices.** This section includes studies that empirically or automatically investigate how developers insert logging statements into the software’s source code and how the logging evolution and improvement can benefit the usage of the logging code.
  - **Automatic log insertion and learning.** We cover the studies that leverage static code analysis, heuristics, and machine learning techniques to automatically add (or improve) logging statements in the source code to make them more effective in failure diagnosis.
  - **Evaluation.** As we study automatic ways of addition and learning of log statements, we introduce several metrics to measure the effectiveness of the proposed approaches.
- **Mining logs.** This part provides insight on methods and tools to analyze log messages and log files. This can be further divided to log management, log parsing, and their applications.
  - **Log management and maintenance.** Management and collection of logs are important as a pre- or post-step of log analysis.
  - **Log parsing.** To enable log message analysis, we first require to parse the log messages and extract their templates.
  - **Application of logs.** We review a wide range of applications that leverage automated log analysis for various software engineering tasks, such as anomaly detection and failure diagnosis.
- **Emerging applications of logs.** We review the recent special interest in applications of logs in other domains such as mobile devices and big data.
- **Opportunities for future work.** Based on the current log-related research, we comment on the future directions and opportunities for each category of logging research.

As our aim is to provide a comprehensive and end-to-end survey of the logging in software, we have covered the topics of *mining and automation of logging statements* and *mining of log files* side-by-side in this survey. We have seen that these topics go hand-in-hand and the synergy between

1. <https://www.zotero.org/>

2. <https://www.jabref.org/>

3. <https://www.core.edu.au/conference-portal>

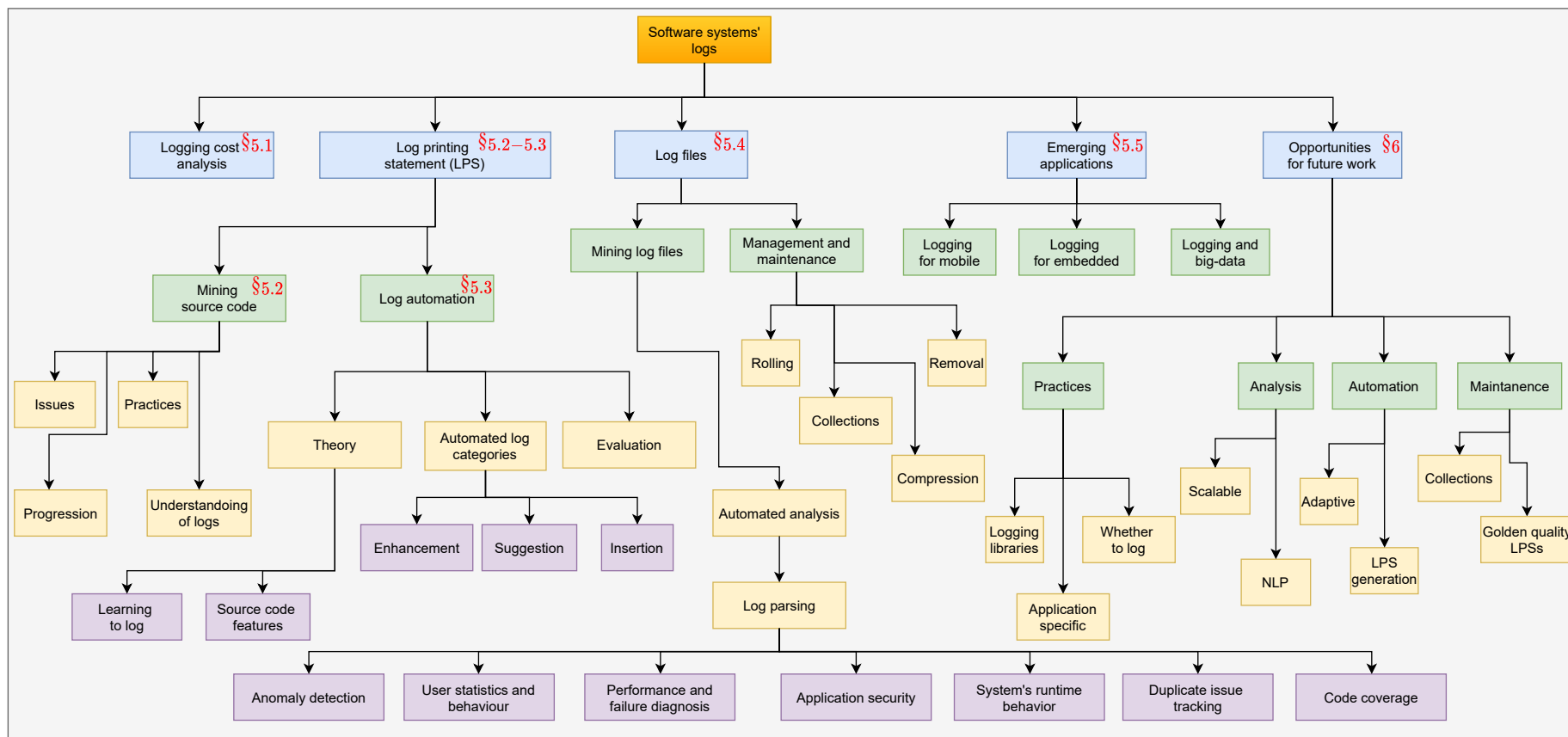

Fig. 6: This figure provides a taxonomy of the present-day logging research. After providing an introduction on logs and log messages in §2, we explain logging costs and benefits in §5.1. Log printing statement research covers two sections, §5.2-5.3, followed by log files' research in §5.4. §5.5 and §6 provide emerging applications and opportunities for future work. We conclude our survey in §7.

them has resulted in more effective logs and logging practices. In fact, the ultimate goal of a mountain of studies for logging statement automation is to *improve various log mining tasks* (Figure 1). For example, *ErrLog* [66] and *LogEnhancer* [67] automatically introduce new logging statements or add additional variables to the logging statements (*i.e.*, **automation of the logging statements**) to improve the quality of logs, and, subsequently, *improve log mining tasks* such as error detection and program diagnosability. In another example, authors of *Log20* [33], an automated log placement tool, explain that the main objective of their log placement tool is to “*disambiguate*” the execution paths, and consequently, improve the effectiveness of log mining methods in “*debugging real-world failures*”. Furthermore, we observe that ignoring the cross-cutting concerns of logging has resulted in log-related issues in the past, such as stale and confusing logging statements, and has hindered effective log file mining [68], [69].

It is also important to mention that there exist additional industry products, with an aggregate market cap beyond \$125B, that perform log analysis for various goals such as performance evaluation, cloud monitoring, and data analytics, to name a few: Datadog [70] (\$49.7B)<sup>4</sup>, Splunk [22] (\$27.3B), Elasticsearch [24] (\$15.5B), Loggly [71] (\$5.7B), Dynatrace [72] (\$22.1B), New Relics Inc. [73] (\$4.9B), and XpoLog [74]. However, this paper mainly focuses on surveying academic works, or peer-reviewed publications from industry. We acknowledge that there is a mountain of work in industry that perform log analysis, however, it is mainly outside the scope of this survey. Additionally, logging is also used in other computing systems, such as embedded, hardware devices/sensors, or mobiles which are generally outside the scope of this survey, as we mainly focus on software systems. However, we briefly mention some of the mobile devices studies that are closely related and have aimed to replicate the efforts in software logging research in Section 5.5. Lastly, Figure 6 summarizes a taxonomy of categorization of modern-day logging research in our survey, and we leverage the classification in this figure to divide the logging research into subtopics and study them in the upcoming sections.

**Finding 1.** *Based on the taxonomy and our literature review, the logging research is spread through twelve categories (topics): ① costs and benefits of logging, ② logging practices, ③ logging progression, ④ log-related issues, ⑤ log printing statement automation, ⑥ log maintenance and management, ⑦ log parsing, ⑧ log-based anomaly detection, ⑨ log-based runtime behavior analysis, ⑩ log-based performance, fault, and failure diagnosis, ⑪ log-based user, business, security, and code-coverage analyses, and ⑫ emerging applications of logs.*

## 4 RQ2: WHAT ARE THE PUBLICATION TRENDS BASED ON VENUES, TOPICS, AND YEARS?

For this RQ, after categorizing the 103 selected publications, we organize the publications based on their venues and

4. Values are collected at the time of this survey from Google Finance. For example for Datadog: <https://www.google.com/finance/quote/DDOG:NASDAQ>

publication years and draw high level trends. Based on our findings from the trends, we summarize some of the log-related challenges that the prior research has aimed to address at the end of this section.

### 4.1 Venue Trends

Table 2 provides a breakdown of surveyed publications per venue. Although looked for, we could not find a related work in TOSEM<sup>5</sup>. The majority of the research in this field is published in EMSE, ICSE, TSE, JSS, and ASE. We suggest the authors of future publications to consider the following venues in Table 2 for submitting their works, and consider the number of related references that their work aligns with in that venue. This ensures their works will receive higher visibility and a thorough comparison with the prior work.

### 4.2 Topic Trends

Figure 7 shows the percentage of publications per each topic. Overall, we have divided the logging research into twelve subcategories (*i.e.*, topics), which we will review throughout this survey. Table 19 (Appendix A) lists the topics and provides the related references for each one. The table serves as a quick-access guide to review the research happening in each topic. Based on our analysis, the top-5 active and popular research topics in the field of logging based on the number of publications are: **1) log mining for anomaly detection, 2) log printing statement automation, 3) log mining for performance and failure diagnosis, 4) log maintenance and management, and 5) log parsing.**

### 4.3 Year Trends

Figure 8 illustrates the number of conference (blue), journal (orange), and archived (gray) publications per year till May 31, 2021. The upward trend on the plot suggests the continuous and growing interest of the research community to explore various dimensions of logging research. The publications are from both academia and industry such as Microsoft [14], [30], [35], Twitter [15], Huawei [124], RIM [68], and others [38]. Additionally, there are valuable research from the synergy between academic researchers and industry teams which further emboldens the efforts by bringing real-world industry experiences [56], [117], [124]. As such, we foresee the research in this area will continue to grow and foster in the upcoming years as there are interesting and promising trends for future research, explained in Section 6.

### 4.4 Logging Challenges

Based on the knowledge gained throughout the survey, we summarize the challenges that the prior literature has aimed to tackle in the following. As a result of a lack of well-accepted standards and guidelines for logging practices [29], [35], [38], currently, developers mostly rely on their personal experience or intuition to perform their logging decisions. However, for this manual process, *i.e.*, developers inserting

5. ACM transactions on Software Engineering and Methodology.

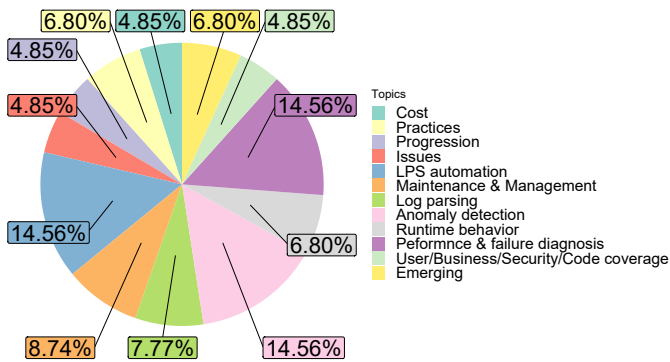

Fig. 7: Percentage of publications in each topic.

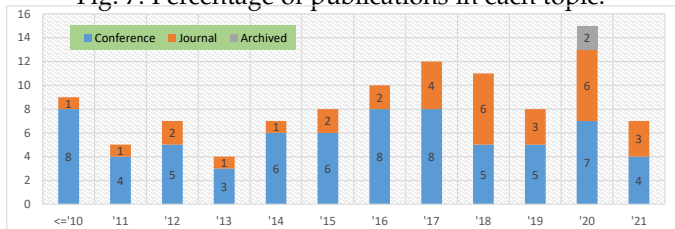

Fig. 8: Number of publications per year divided into conference and journal categories. Publications up to May 31, 2021 has been observed at the time of this survey.

logging statements into the source code, to lead to effective logging practices, we are facing four main challenges:

- 1) The first challenge is **where-to-log**, which is the decision of selecting appropriate logging points. Logging statements can be placed in different locations of interest in the source code, such as inside *try-catch* block, *function return value*, etc. Although log statements pro-

vide valuable insight into the running system's state, they are I/O intensive tasks and excessive logging can incur performance and maintenance overhead [33], [117]. Consequently, developers are often faced with the challenge of making an informed decision for *where-to-log* in order to avoid introducing unjustified performance degradation and maintenance overhead.

- 2) The second challenge, **what-to-log**, concerns with what information to include in the log message. As explained in Figures 2 and 3, the log statement description provides a brief context of the execution and the internal variables provide more insights into the dynamic context of the current execution state. Therefore, the logging description and logged variables should satisfy their purpose and be clear and informative about the current state of the program. The logging description should also stay up-to-date and in-sync with the feature code updates, as some developers fail to update the logging statements as feature code changes [91], [148].
- 3) The third challenge is **how-to-log**, which concerns with how the logging code, as a subsystem, combines with the rest of the software system. As the logging code is intertwined across different source code modules, some prior researchers have suggested modularizing the logging code, as an independent subsystem, which becomes compiled into the feature code in the later stages of the system release [149], [150]. Nevertheless, many industrial and open-source software projects still tend to mix the logging code with the feature code [28], [29], [38], [77]. As a result, maintaining and developing high-quality logging code as the feature code evolves remains challenging and crucial to the overall quality of the software.
- 4) The fourth challenge, and also the recent [51] and mostly overlooked in prior research [30], discusses the

No.	Type	Name (# of publications)	Abbr.	References	No.	Type	Name (# of publications)	Abbr.	References
1.	J	Empirical Software Engineering (12)	EMSE	[69], [75], [76], [77], [78], [79], [80], [81], [82], [83], [84], [85]	10.	C	IEEE International Conference on Data Mining (3)	ICDM	[4], [86], [87]
2.	C	International Conference on Software Engineering (11)	ICSE	[8], [14], [28], [29], [30], [35], [38], [50], [88], [89], [90]	11.	C	Mining Software Repositories (3)	MSR	[91], [92], [93]
3.	J	IEEE Transactions on Software Engineering (5)	TSE	[37], [94], [95], [96], [97]	12.	C	International Symposium on Software Reliability Engineering (3)	ISSRE	[17], [98], [99]
4.	J	Journal of Systems and Software (5)	JSS	[39], [68], [100], [101], [102]	13.	C	ACM Joint European Software Engineering Conference and Symposium on the Foundations of Software Engineering (2)	ESEC/FSE	[103], [104]
5.	C	International Conference on Automated Software Engineering (4)	ASE	[56], [105], [106], [107]	14.	C	International Conference on Software Analysis, Evolution and Reengineering (2)	SANER	[69], [108]
6.	C	USENIX Symposium on Operating Systems Design and Implementation (4)	OSDI	[9], [66], [109], [110]	15.	C	International Conference on Architectural Support for Programming Languages and Operating Systems (2)	ASPLOS	[6], [111]
7.	C	IEEE/IFIP Conference on Dependable Systems and Networks (4)	DSN	[112], [113], [114], [115]	16.	C	USENIX Annual Technical Conference (2)	ATC	[116], [117]
8.	C	International Symposium on Reliable Distributed Systems (4)	SRDS	[118], [119], [120], [121]	17.	C	ACM Symposium on Applied Computing (2)	ACM SAC	[36], [122]
9.	C	ACM Symposium on Operating Systems Principles (3)	SOSP	[2], [10], [33]					

TABLE 2: List of related venues for our survey sorted from the most to least number of references. J stands for journal, and C stands for conference, symposium, or workshop. The list of additional venues with only one publication include: arXiv [123], [124], CSUR [65], TOCS [67], TPDS [125], IEEE Software [57], TSMCA [126], TNSM [127], SP&E [128], JCST [129], HiPC [130], CSRD [131], IJCAI [132], NSDI [7], CIKM [133], CCS [5], SIGKDD [134], IMC [135], MASCOTS [136], WSE [137], IWQoS [138], ICWS [139], ICPC [140], ICSEM [141], ICPE [142], ICC [143], Middleware [144], VLDB [15], CNSM [13], APSYS [145], HICSS [146], and COMPSAC [147]. The total number of listed papers is 103.



question of **whether-to-log**, which concerns with dynamically adjusting the degree of logging in response to the runtime requirements. For example, if a suspected anomaly is detected, the logging platform can enable more detailed logging, and if the system is acting normal, it minimizes the number of logs to lessen the overhead.

Figure 9 summarizes the logging practices challenges. In the following, we briefly review the related research concerning each challenge. Later on, we will revisit these research efforts in more detail in their related section in the survey.

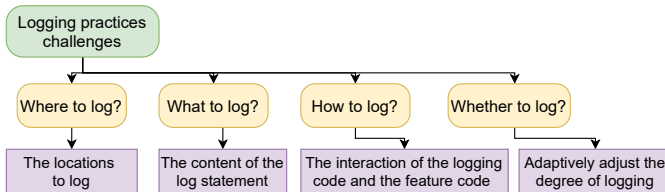

Fig. 9: Logging practice challenges.

#### 4.4.1 Where to log

The research in this area is interested in finding appropriate logging points. One approach is to analyze the source code and look for specific types of code blocks, *i.e.*, unlogged exception code blocks, and insert logging statements inside them [66]. Other log placement objectives, such as disambiguating execution paths [33], minimizing the I/O and performance overhead [117], and feature extraction and learning approaches [30], [35] also exist in the literature.

#### 4.4.2 What to log

The research in this area is concerned with with what the content of logging statements should be to make the logs more effective for future system observation purposes, such as debugging and failure diagnosis. Possible approaches include *automatically adding variables* that can clarify execution paths to the LPSs [67], [97]. Additionally, concerns on the content of logging statements arise when developers neglect to update the LPSs as the related feature code is updated [91], which is also a common problem in *source code comments* [151].

#### 4.4.3 How to log

This avenue is concerned with the problem of how to develop and maintain a high-quality logging code. Additionally, it pays attention to the interaction and integration of the logging code as a subsystem with the rest of the software system. Paradigms such as Aspect Oriented Programming (AOP) [149] aim to look at log statements as a submodule of the software which is separate from the feature code, and unifies with the rest of the software at a later time during the development process. However, the current logging practices in the industry and open-source projects commonly fuse the logging code inside the feature code. Logging libraries and utilities [50] also take part in organizing the logs and improving their formatting and quality. As such, enhancement of logging libraries can positively impact on ensuring *how we log*.

#### 4.4.4 Whether to log

One approach to tackle the challenge of the number of logs is to enable dynamic filtering of logs during runtime [51], [117]. Enablement of this paradigm would allow to take the pressure off the developers and enable more conservative addition of log statements in the source code, without being concerned about the overhead. Thus, depending on the program state, logs are dynamically discarded or collected if they serve any online or postmortem analysis purpose.

**Finding 2.** The top five research topics for logging research are: ① log mining for anomaly detection, ② log printing statement automation, ③ log mining for performance and failure diagnosis, ④ log maintenance and management, and ⑤ log parsing.

**Finding 3.** The top five publications venues for logging research are: ① Empirical Software Engineering (EMSE), ② International Conference on Software Engineering (ICSE), ③ Transactions on Software Engineering (TSE), ④ Journal of Systems and Software (JSS), and ⑤ Automated Software Engineering Conference (ASE).

**Finding 4.** Due to the challenges associated with logging, *i.e.*, what, where, whether, and how to log, there exists a continuously growing interest in log-related research and the prior work is published in top-ranked venues in yearly basis (Figure 8 and Table 2).

### 5 RQ3: HOW THE RESEARCH IN EACH TOPIC CAN BE SYSTEMATICALLY COMPARED WITH THEIR APPROACHES, PROS AND CONS?

In this section, we review the available literature in each category of logging research and provide a comparative analysis.

#### 5.1 Category A: Logging Cost and Benefit Analysis

Although logs are useful and provide insight into the internal state of the running software, they also impose inherent costs on different subsystems of a computer system. We can assess the costs and benefits of logging both *quantitatively* and *qualitatively*, which we review in the following.

##### 5.1.1 Quantitative assessment

Quantitative assessment for benefits of logging measures to what extent logging improves a specific debugging task. For example, Yuan et al. [66] observed the benefits of improved logs, as they contributed to  $\sim 60\%$  faster diagnosis time when compared with the original logging statements, *i.e.*, prior to the enhancement. Log associated overheads can be also evaluated quantitatively [117], [143]. Table 3 summaries **logging cost breakdown** on various subsystems of a computing system [117], including I/O, storage, CPU, and memory. For example, one approach [33] to simplify and **measure the slowdown** caused by logging statements is to calculate the number of times ( $n$ ) each log statement is being executed and multiply that with the overhead of a single log statement execution ( $l$ ), *i.e.*,  $n \times l$ . Other research efforts in this area have measured the **overhead of Linux security auditing through log messages** by enabling and disabling audit logging [143], and statistically **mapped logging statements to the performance of the system**, *i.e.*, CPU usage [76], [142].

Overhead	Details
Disk I/O bandwidth	Logging causes additional I/O bandwidth (BW) which may interfere with the required I/O BW for the system’s core functionality. The BW requirement by enabling all logs ( <i>i.e.</i> , <i>verbose</i> level vs. <i>medium</i> level) can become significantly higher than the presumed BW. For example, in [117], the extra BW by enabling all logs is 8MB/s, which, however, should have been $\leq 200\text{KB/s}$ .
Storage	As the logging BW increases, OS might slow down, and other processes that require disk space and BW may crash, and even the logging subsystem could crash. Additionally, more logging requires more storage space.
CPU	As the CPU usage of the logging subsystem is increased, service to other processes is slowed down. Once the CPU usage of logging goes up to double digits, the slowdown of the other processes becomes significantly noticeable. Ding <i>et al.</i> [117] recommend an overhead of 3-5% as the CPU usage upper bound for logging.
Memory	Developers noticed unexpected increases in memory usage of the logging subsystem, which was the root cause of one service incident. Additionally, memory leakage of the logging system caused days of effort in debugging.

TABLE 3: System’s performance overhead associated with logging.

Reference - Approach	Results	Type	Pro	Con
Yuan <i>et al.</i> [66] - Conservatively adds log statements to the source code while aiming to minimize the introduced execution overhead.	This study categorized seven generic patterns of error sites based on the study on 250 failures, such as exceptions, function return errors, <i>etc.</i>	Quan./Qual.	Errlog provides three different levels of configurable logging overhead.	Focuses on Error Logging Statements (ELS).
Zeng <i>et al.</i> [143] - Measures the overhead of Linux security auditing through log messages.	The authors measured up to 5% performance overhead when the audit logging is enabled.	Quan.	Proposes an adaptive approach to reduce the overall system overhead from 5% to 1.5%	Reduced auditing might result in a lower level of security protection for the system.
Ding <i>et al.</i> [117] - Surveys engineers in Microsoft and applies a constraint solving-based method to calculate an optimal logging placement.	Maximizes extracted runtime information and, concurrently, minimizes the I/O and performance overhead.	Quan./Qual.	Two levels of filtering, <i>i.e.</i> , local and global filters, to discard less-informative logging messages and simultaneously keep important messages.	Curtailed to performance analysis of logs, and falls short for logs recording error and failure information.
Li <i>et al.</i> [37] - Studies developers’ logging considerations when it comes to the costs and benefits associated with logging.	Main benefits of logging communicated by developers include: <i>diagnosing runtime failures, using logs as a debugger, user/customer support and system comprehension.</i>	Qual.	Survey of 66 developers and a case study of 223 logging-related issue reports from the issue tracking systems.	Limits to open-source projects and closed-source projects might evaluate differently on their logging costs and benefits.
Yao <i>et al.</i> [76] - Introduces a statistical approach to map logging statements to the performance of the system, <i>i.e.</i> , CPU usage.	If the performance model’s prediction error is noticeably impacted, it implies that the modified log helps to model the CPU usage properly.	Quan.	The approach finds and suggests removing insignificant log statements.	Logging statements that are not covered by the performance tests cannot be identified by this approach.

TABLE 4: Logging cost and benefit research - Topic (A). ‘Type’ shows *qualitative*, *quantitative*, or both.

### 5.1.2 Qualitative assessment

In contrast to quantitative metrics for measuring logging overhead, *e.g.*, system slowdown or I/O cost, qualitative approaches aim to understand the underlying trade-offs from developers’ perspectives through surveys or questionnaires. A developer survey at Microsoft [117] uncovered main overheads associated with logging, from developers’ perspective, as listed as “*Details*” in Table 3. Developers were also inquired about the methods they use for containing the logging overhead for large-scale online service systems. They mentioned a variety of methods to limit the logging overhead such as **adjusting the logging verbosity level** (93% of developers have applied this approach), **manual removal of unnecessary logs** (64%), and **periodic archiving of log files** to save disk space (43%). Additionally, this study observed the lack of a cost-awareness guideline during log instrumentation. Some developers often had little idea about the logging overhead when they planned to add new logging statements to the source code. Thus, developers require to be more mindful in adding logging statements in scenarios such as a *for-loops*, which iterates a large number of times and could cause high overhead, especially on CPU, I/O, and storage throughput. A recent study [37], **qualitatively** examined logging cost and benefits from developers’ perspectives. One qualitative measure of the logging cost, *i.e.*, too much logging, causes **noisy log files** which hinders

program comprehension and results in strenuous log file analysis. In contrast to costs associated with logging, main qualitative benefits of logging communicated by developers include **the capability to diagnose runtime failures with logs, using logs as a debugger, user/customer support, and system comprehension**. Table 4 summarizes the research in Category A.

## 5.2 Mining Log Printing Statements

There has been a significant body of research aiming to mine, understand, and characterize various source code logging practices [28], [29], [35], [77]. Because, intuitively, understanding previously applied logging practices is the gateway to help developers improve their current logging habits. Thus, to derive the in-the-field LPS practices, the first step is to mine the source code’s logging statements and extract useful insight and observable patterns. Consequently, there are two broad classes of prior studies that have sought after understanding and mining of the logging practices in both industry and open-source projects: 1) **mining logging code**, and 2) **mining log files**. We review the research for mining logging code in this section and mining of log files in Section 5.4.

Mining log printing statements (LPSs) in the source code principally focuses on understanding how developers insert LPSs in to the source code and how logging code

Reference - Aim	Experiments	Results	Pro	Con
Yuan <i>et al.</i> [28] - Study and characterize logging practices in four open-source C/C++ based projects.	Four software projects: <i>Apache httpd</i> , <i>OpenSSH</i> , <i>PostgreSQL</i> , and <i>Squid</i> .	Observes ten findings and their implications that software logging is pervasive and developers spend significant time maintaining logging code.	Provide a simple checker to detect verbosity level inconsistencies.	A follow-up study observed contradictory findings in some cases [77].
Fu <i>et al.</i> [35] - Conducts source code analysis on two software systems at Microsoft, to categorize logged and unlogged snippets.	A questionnaire and a decision-tree classifier to detect whether a code snippet requires a logging statement.	The research uncovers five categories of logged code snippets, including <i>return-value-check</i> and <i>exception-catch</i> snippets.	Extracts contextual features and proposes a decision-tree classifier, which can detect whether a code snippet requires a logging statement.	Logging categories can be broken down further into subcategories.
Pecchia <i>et al.</i> [38] - Studies the logging practices on a critical industrial software at Selex ES.	Experimented with the software at Selex ES in three product lines, <i>i.e.</i> , middleware (MW), business logic (BL), and human-machine interface (HMI).	The study uncovers three main reasons for logging in the industrial domain: state dump, execution tracing, and event reporting.	Observed logging is highly developer-dependent, and company-wide <b>log policies</b> and <b>guidelines</b> are needed.	The study is limited to a very particular closed-source software system, and the findings might not generalize to software in other application domains.
Shang <i>et al.</i> [78] - Explores the relationship between logging characteristics and the code quality.	A case study on four releases of Hadoop and JBoss projects.	Logging characteristics provide a strong indicator of post-release defects, <i>i.e.</i> , files with more logging statements have a higher rate of post-release defect compared to the files without logging.	Developers' code improvement efforts should focus more on the source code files with high logging density or high rate of log churn.	The study cannot establish a causal relationship, <i>i.e.</i> , there might be a large portion of defects not captured due to not being logged extensively.
Chen and Jiang [77] - A replication work of Yuan <i>et al.</i> 's work [28] on 21 Java projects.	21 open-source Java projects in three different domains: <i>server</i> , <i>client</i> , and <i>supporting components</i> .	Similar findings as [77] regarding logging pervasiveness and that developers' significant amount of time spent on maintaining the logging statements.	A high portion of code updates are for improving the quality of logs and contrary to [77], this research finds developers spend more time fixing reported failures when log messages are present.	Contradictory findings compared to the prior work [77] raises the concern of how useful the findings are, and if logging practices are project, programming language, and domain dependent.
Zhi <i>et al.</i> [152] - Conducts an exploratory study on the logging configuration practices and how they evolve over time.	10 open-source and 10 industrial java projects in various domains and sizes.	The research's main findings show that current practices of logging configurations concerns with logging management, logging storage, logging formatting, and logging-configuration quality.	Provides a simpler checker to statically analyze and detect log configuration issues. The authors found some issues on open-source projects by applying the checker.	Further research to improve the quality of logging configurations is required to detect and resolve logging configuration smells.
Chen <i>et al.</i> [50] - Studies logging utilities (LUs) usage in Java project.	Over 11,000 projects and 3,850 Java LUs (e.g., SLEF4J [49]) from GitHub.	With a heuristic-based technique, the study observed a positive correlation between the size of the project and the complexity of LUs.	Some projects still use multiple LUs to bring in more flexibility, and, additionally, support and enable logging behavior of the imported packages.	Currently, configuring different LUs is a manual and error-prone task. Thus, error-free and automatic checkers and techniques to configure LUs are required.

TABLE 5: Logging practices research - Topic (B).

evolves over time to gain insight into the common logging practices. Figure 10 shows the categorization of research for logging code mining of software projects which is divided to research on **logging practices (Category B)**, **logging code progression (Category C)**, and **logging-code issues (Category D)**. In the tables that follow, our convention is that *pro* signifies an *advantage*, or an *improvement*, and *con* signifies a *limitation*, *room for improvement*, or an *avenue for future work*. This section includes research in Categories B, C, and D, that we review in detail.

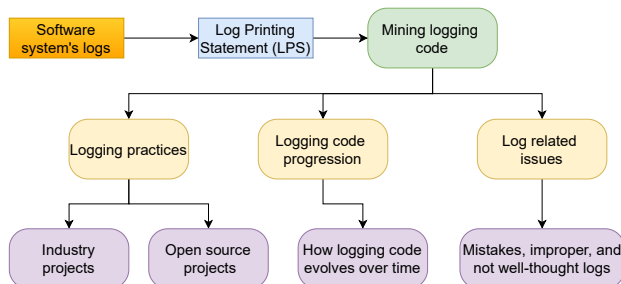

Fig. 10: Logging code mining research in subcategories.

### 5.2.1 Category B: Logging Practices

Mining logging practices aims to gain insight into the current logging habits of developers both in open-source and industrial proprietary software projects.

**Open-source projects.** Prior work in this category includes empirical studies to characterize current logging practices in open-source projects such as Apache Software Foundation (ASF) [153] projects [28], [77]. Other works [77], [78] aimed to find recurrent mistakes in the logging code and its relationship to overall source code quality. Another tread of research [50], [152] has examined logging configurations, libraries, and utilities.

**Industry projects.** Similar to the open-source software, software logging is a widely adopted practice in industry projects. Fu *et al.* [35] conducted a study on logging practices of two software systems at Microsoft, and Pecchia *et al.* [38] examined application-critical software logging practices at Selex ES.

Table 5 summarizes and compares the research on mining of the logging source code for open-source and industrial projects. In sum, logging is a **pervasive convention** in various software domains (*e.g.*, server, client, and support applications) and developers utilize **various logging**

Reference - Aim	Experiments	Results	Pro	Con
Shang <i>et al.</i> [68], [154] - Explores the progression of logging code in execution ( <i>i.e.</i> , log files) and source code levels.	Two open-source ( <i>Hadoop</i> and <i>PostgreSQL</i> ) and one industrial ( <i>EA</i> ) software projects.	The logging code changes at a high rate across versions, which might break the functionality of log processing applications (LPA).	Developers could avoid the majority of the logging code modifications through better logging designs.	The broad range of the avoidable logging code changes raises the concern of if the observed values are software system dependent.
Kabinna <i>et al.</i> [91] - Studies the logging library migrations in Apache Software Foundation (ASF) projects.	Studies 223 ASF projects with their issue tracking systems in JIRA.	As more flexible logging libraries with additional features emerge, many ASF projects have undergone logging library migrations or upgrades.	Although adding more flexibility and performance improvement are cited as the primary drivers for logging library migrations, performance after library migration is rarely improved.	A questionnaire survey from developers involved in logging migration efforts can bring additional value and more insight into their rationale behind the logging updates and best practices.
Kabinna <i>et al.</i> [69], [155] - Investigates the stability of logging statements over time, <i>i.e.</i> , whether a logging statement will go under revisions in the future.	Four open-source projects: <i>Liferay</i> , <i>ActiveMQ</i> , <i>Camel</i> and <i>CloudStack</i> .	A significant portion of logging statements change throughout their lifetime, and factors such as file ownership can affect the stability of logging statements.	Developers of LPAs should rely on more stable logging statements for designing their tools.	The research considers only the first change of logging statements. However, the already changed logging statements might become more stable after going through modifications and prior fixes.
Li <i>et al.</i> [79], [156] - Studies the co-evolution process of logging statements as bug fixes and feature code updates are committed.	12 open-source projects in C/C++ language from various domains, including <i>Httpd</i> , <i>Rsync</i> , <i>Collectd</i> , <i>Postfix</i> , and <i>Git</i> .	Proposes LogTracker, a tool that proactively predicts log revisions by correlating the rules learned from historical log revisions, <i>e.g.</i> , the logging context, and the feature code.	Utilizes code clones to learn log revision rules with the insight that semantically similar codes will likely require similar logging revisions.	The tool can only guide log revisions for codes that share similar logging context, and the percentage of these revisions is not substantial.
Rong <i>et al.</i> [157] - Investigates the status of developers' <i>intention</i> and <i>concerns</i> (I&C) on logging practices.	Developers' interviews and code analysis on three industrial software projects.	Major gaps and inconsistencies exist between the developers' I&C and real log statements in the source code.	For reasons such as <i>lack of supporting facilities</i> and the <i>version evolution of source code</i> , the developers' I&C are poorly reflected in the log statements.	Only missing log statements are considered as inconsistencies, and unnecessary log statements are not evaluated.

TABLE 6: Logging code progression research - Topic (C).

practices and spend a **significant amount of time** updating logging statements.

### 5.2.2 Category C: Logging Code Progression

So far, we have discussed the research investigating logging practices in both open-source and industry projects. Prior research has also studied the progression (*i.e.*, evolution) of the logging code in software projects. Progression means that how logging code changes over time. Prior studies have concluded that logging code **evolves significantly** (*i.e.*, high churn rate), even at a higher rate than the *feature code* over the lifespan of the software development [28], [33], [68], [69], [154], [155]. Additionally, many projects go through logging library migrations throughout their lifetime [91], and research has proposed tools to predict likely logging code revisions, *e.g.*, LogTracker [79], [156]. Table 6 provides additional details and summarizes the research on the progression of the logging code.

### 5.2.3 Category D: Log-related Issues

The extensive usage of logs comes with mistakes, improper, and not well-thought logging practices, which results in logging issues and low-quality logging statements. Some of the research in this thread overlaps with *logging practices* and *logging code progression*, as some of the logging issues are uncovered during the examination of logging practices and their evolution. Yaun *et al.* [110] presented a characteristic study on real-world failures in distributed systems, and observed that the majority of failures print explicit failure-related log messages which can be used to replay (*i.e.*, recreate) the failures. However, recorded

log messages are noisy, which makes the analysis of logs tedious. Several efforts have aimed to identify and reduce log-related issues, such as finding recurrent **logging mistakes**, *i.e.*, anti-patterns [29], **adjusting verbosity levels** (sometimes back-and-forth), **adding missing variables**, **modifying static text** to fix inconsistencies [28], and finding **logging code smells** [94], [158], *i.e.*, duplicates. Hassani *et al.* [80] empirically categorized log-related issues in open-source projects, among them **inappropriate log messages** and **missing logging statement itself** (also [33]) in locations that have to be logged. The detection of logging code issues would be helpful, as developers can add revisions to logging statements, and hence improve the quality of log statements. As such, in addition to tools that automatically detect log-related issues such as DLFinder [158] and LCAalyzer [29], future research will benefit from developing tools that can automatically *fix* log-related issues. In addition, due to the lack of proper communication with developers of large-scale software systems, practitioners, who review logs for software maintenance tasks, might encounter challenges in understanding the logging messages. Such challenges may hamper the effectiveness and correctness of leveraging logs. Therefore, utilizing development knowledge [148], in particular issue reports for log statements, *e.g.*, JIRA tickets [159], can help practitioners to better understand log messages. Shang *et al.* [148] identified five categories of information that practitioners often look for to understand in log messages: **meaning**, **cause**, **context**, **impact** of the log message, and the **solution** for the log message. The key takeaway is that leveraging development knowledge, such as issue reports and code commit information, helps in clarifying the

Reference - Aim	Experiments	Results	Pro	Con
Yuan <i>et al.</i> [110] - Presents a characteristic study on real-world failures in distributed systems to understand how faults evolve to user-visible failures.	198 user-reported failures that occurred on <i>Cassandra</i> , <i>HBase</i> , <i>HDFS</i> , <i>Hadoop MapReduce</i> , and <i>Redis</i> .	The majority of failures print explicit log messages which can be used to replay ( <i>i.e.</i> , recreate) the failures. However, the recorded log messages are noisy, which makes the analysis of logs tedious.	Provides a simple rule-based static checker, <i>Aspirator</i> , to detect the location of the code bug patterns, including log-related issues.	The study limited to a set of data-intensive systems in their production quality, <i>i.e.</i> , not during the development phase.
Shang <i>et al.</i> [148] - Utilizes development knowledge [118], <i>e.g.</i> , JIRA tickets [159] to understand the intention of log statements.	300 randomly sampled logging statements, and manually examining the email threads in the mailing list for three open-source systems: <i>Hadoop</i> , <i>Cassandra</i> , and <i>Zookeeper</i> .	Identifies five categories of information that practitioners often look for to understand in log messages: <b>meaning</b> , <b>cause</b> , <b>context</b> , <b>impact</b> of the log message, and the <b>solution</b> for the log message.	The approach can be used to identify the experts for a particular log line and seek their help.	Development knowledge is considered for log lines at the method level. The higher the level, the more development knowledge that can be attached, but the more overwhelming such attached knowledge might become.
Chen and Jiang [29] - Characterizes anti-patterns (AP) ( <i>i.e.</i> , recurrent mistakes) in the logging source code.	352 log changes from three systems: <i>ActiveMQ</i> , <i>Hadoop</i> , and <i>Maven</i> .	Finds six different anti-patterns in the logging code, such as wrong log levels and logging nullable objects, and proposes a tool, <i>LAnalyzer</i> , to detect anti-patterns.	The approach learns anti-patterns from how developers fix the defects in their logging code.	The work detects APs based on the independent historical changes to the logging code and falls short in detecting APs in cases that there has not been an update to the logging code.
Hassani <i>et al.</i> [80] - Studies log-related issues for open-source software projects.	563 log-related JIRA issues from <i>Hadoop</i> and <i>Camel</i> projects.	As per authors findings, among the most common logging code issues are: 1) <i>inappropriate log messages</i> , 2) <i>missing logging statements</i> , 3) <i>inappropriate log verbosity levels</i> , and 4) <i>log library configuration issues</i> .	Developed a tool to detect incorrect log verbosity levels based on the words that appear in the logging statement's description.	Log-issue checkers are threshold-dependent and in some cases result in a low number of detected issues.
Li <i>et al.</i> [94], [158] - Studies issues with duplicate logging statements, which are logging statements that have the same static text messages.	4K duplicate logging statements in five open-source projects: <i>Hadoop</i> , <i>CloudStack</i> , <i>Elasticsearch</i> , <i>Cassandra</i> , and <i>Flink</i> .	Repetitive logging statement descriptions can be potential logging code smells [160], <i>i.e.</i> , a problematic duplicate logging code, which can have a detrimental or misleading effect in the understanding of the dynamic state of the system.	Uncovers five categories of duplicate logging code smells and proposes a static analysis tool, <i>DLFinder</i> , to automatically detect duplicate logging code smells.	The research eliminate the top 50 most frequent words when detecting log message mismatch (LM), which might cause false negatives.

TABLE 7: Log-related issues research - Topic (D).

log messages. Table 7 summarizes the research in Category D.

### 5.3 Category E: Log Statement Automation

As mentioned earlier, execution logs, which are the output of logging statements in the source code, are a valuable source of information for system analysis and software debugging. Thus, high-quality logging statements are the precursor of the effective log file mining and analysis. Conversely, low-quality LPSs result in log-related issues (Section 5.2.3), and they hinder the understanding of software problems whenever they happen. Currently, due to the *ad-hoc* nature of logging, lack of general guidelines, and because developers mostly insert logging statements based on their personal experiences, the quality of log statements can hardly be guaranteed [145]. Therefore, automated logging which aims to add or enhance log statements inside the source code either proactively or interactively is a well-motivated effort and can improve the quality of logging statements and, ultimately, result in more effective log mining tasks.

Figure 11 presents the log statements' research with emphasis on automated logging. As per this figure, we review the theory behind the automated logging, automated logging approaches, and how they are evaluated. Prior studies have suggested creating and utilizing statistical models from common logging practices, and to learn logging heuristics from experience, and use them to provide **new logging suggestions** or **enhance the already existing LPSs**.

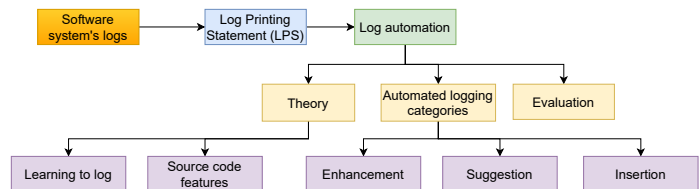

Fig. 11: Logging research with the emphasis on logging code automation research, Category E.

#### 5.3.1 Log Automation - Motivation and Theory

One of the common approaches for log automation is the application of machine learning methods to predict whether a code snippet needs a logging statement by training a model on a set of logged code snippets, and testing it on a new unlogged code set, *i.e.*, supervised learning. In this section, we first review the background and theory for machine learning methods and continue with automated logging approaches.

**Motivation.** With the ever-increasing size of software systems, it is most likely that a single developer is in charge of developing only a small subsystem of the whole software system. Under this situation, making wise logging decisions becomes quite challenging as developers do not have full knowledge of the whole system [30]. As logs are quite pervasive and useful for system maintenance [161], if the logging decisions can be learned automatically, a log suggestion tool can be constructed to help developers making better decisions. Ultimately, such a tool can increase

Reference - Aim	Experiments	Results	Pro	Con
Zhang <i>et al.</i> [145] - Proposes <i>AutoLog</i> , which generates additional informative logs to help developers discover the root cause of a software failure.	Performs a proof-of-concept case study on Apache Hadoop Common.	AutoLog embeds a two-stage process of <i>log slicing</i> and <i>log refinement</i> of the program to narrow down the execution paths that could have led to the system's failure.	The approach narrows down the execution paths that could have led to a system's failure. AutoLog is targeted for interactive in-house development.	The program needs to be re-executed every time new log statements are added, which is time-consuming.
Yuan <i>et al.</i> [67] - Proposes a tool, <i>LogEnhancer</i> , to find and add useful variables to log statements.	Evaluated on a total of 9,125 log messages from eight applications in different domains, including <i>apache httpd</i> , <i>postgresql</i> , and <i> cvs</i> .	LogEnhancer is effective in automatically adding a high percentage of log variables, on average, 95.1%, that programmers manually included.	The tool performs static analysis on the source code starting from the log statement and navigates backward to find variables that are causally along the path that results in the execution of the log statement.	As LogEnhancer's improvement is limited to the existing log statements, its effectiveness diminishes if the logging statements are missing.
Zhu <i>et al.</i> [30] - Proposes <i>LogAdvisor</i> , which aims to provide logging suggestions for <i>exception</i> and <i>return-value-check</i> code blocks.	Two industrial software systems from Microsoft and two open-source software systems from GitHub ( <i>SharpDevelop</i> and <i>MonoDevelop</i> ).	LogAdvisor achieves a high <i>balanced accuracy</i> , ranging from 84.6% to 93.4%, to match developers' logging decisions, and the decision tree model achieves the highest scores.	Trains a machine learning model ( <i>e.g.</i> , SVM and decision trees) to predict whether a focused code snippet requires a logging statement.	It is focused and limited to two categories of code snippets: 1) <i>exception snippets</i> and 2) <i>return-value-check</i> .
Lal <i>et al.</i> [147] - Introduces <i>LogOptPlus</i> tool for automated <i>catch</i> and <i>if</i> code block logging prediction.	Two open-source projects: <i>Apache Tomcat</i> and <i>CloudStack</i> .	The prediction model with random forest achieves the highest F1-score 80.70% (Tomcat) and 92.25% (CloudStack) for <i>if-block</i> logging prediction.	Applies five different learning techniques, <i>e.g.</i> , AdaBoost, Gaussian Naive Bayesian, and Random Forests achieve the highest Precision and Recall.	It is limited to specific code blocks, <i>i.e.</i> , <i>if-block</i> and <i>catch clause</i> .
Zhao <i>et al.</i> [33] - Introduces <i>Log20</i> , a tool that finds a placement of logging statements to minimize execution path ambiguity.	Evaluated on four open-source Java projects: <i>HDFS</i> , <i>HBase</i> , <i>Cassandra</i> , and <i>ZooKeeper</i> .	Log20 achieves a lower logging overhead with the same level of informativeness ( <i>i.e.</i> , entropy) compared to existing logging statements by developers.	It applies Shannon's information theory equation to measure the entropy of the program by approximately considering all of the possible execution paths.	The approach does not consider developers' concerns and practices, does not explain the static content of LPSs, and change of workload can cause extra logging overhead.
Li <i>et al.</i> [81] - Analyzes log changes in open-source projects and proposes commit-time logging suggestions.	Four open source projects: <i>Hadoop</i> , <i>Directory Server</i> , <i>Commons HttpClient</i> , and <i>Qpid</i> .	Performs a manual analysis on four software systems and categorizes the changes to logging statements into four major groups: 1) <i>block change</i> , 2) <i>log improvement</i> , 3) <i>dependence-driven change</i> , and 4) <i>logging issues</i> .	Proposes a random forest classifier for each code commit to suggest whether a log change is required. The classifier's balanced accuracy for within-project suggestions is 0.76 to 0.82.	As the model is trained on prior log changes, it might miss scenarios that there are no prior logging changes to learn from.
Li <i>et al.</i> [82] - Determines the appropriate log verbosity level for the newly-developed logging statement.	Analyzes four open source projects: <i>Hadoop</i> , <i>Directory Server</i> , <i>Hama</i> , and <i>Qpid</i> .	Collected five categories of quantitative metrics that play important roles in determining the appropriate log level: <i>logging statements metrics</i> , <i>containing block metrics</i> , <i>file metrics</i> , <i>change metrics</i> , and <i>historical metrics</i> . Achieves AUC in the range of 0.75 to 0.81 for log level prediction.	Metrics from the block which contains the logging statement, <i>i.e.</i> , the surrounding block of a logging statement, play the most important role in the ordinal regression models for log levels.	The results show that the ordinal regression models for log level prediction are project-dependent.
Jia <i>et al.</i> [108] - Proposes, <i>SmartLog</i> , which is an intention-aware error logging statement (ELS) suggestion tool with two intention models: IDM and GIDM.	Experiments on six open-source projects in C/C++: <i>Httpd</i> , <i>Subversion</i> , <i>MySQL</i> , <i>PostgreSQL</i> , <i>GIMP</i> , and <i>Wireshark</i> .	It improves on the Recall values (average of 0.61) and achieves higher scores compared to LogAdvisor [30] (average of 0.45) and Errlog [66] (average of 0.18).	This work improves on prior work by going beyond code patterns and syntax features, and considers source code intentions, <i>i.e.</i> , semantics.	This work is limited to ELS prediction, <i>i.e.</i> , <i>exception</i> and <i>function return-value</i> logging.
Anu <i>et al.</i> [141] - Proposes a method to make the logging level decisions by understanding the logging intentions.	Four open-source software projects: <i>Hadoop</i> , <i>Tomcat</i> , <i>Qpid</i> , and <i>ApacheDS</i> .	It reaches AUC values higher than 0.9 in log level prediction. The approach extracts the contextual features from logging code snippets and leverages a machine learning model ( <i>i.e.</i> , a random forest model) to automatically predict the verbosity level of logging statements.	As a proof of concept, the authors also implement a prototype tool, <i>VerbosityLevelDirector</i> , to provide guidance on log verbosity level selection in focused code blocks.	The work is limited to focused code blocks: <i>exception handling blocks</i> and <i>condition check blocks</i> .
Liu <i>et al.</i> [97] - Presents an approach to recommend the variables to include in logging statements.	Evaluates on nine open-source Java projects: <i>ActiveMQ</i> , <i>Camel</i> , <i>Cassandra</i> , <i>CloudStack</i> , <i>DirectoryServer</i> , <i>Hadoop</i> , <i>HBase</i> , <i>Hive</i> and <i>Zookeeper</i> .	The approach first learns "rules" from existing logged code snippets by extracting contextual features with deep learning recurrent neural networks (RNN). The approach outperforms five baselines, including random guessing and IR methods in log variable prediction.	The tool provides a ranked list of variables that probably are required logging to the developer.	The method only considers the code preceding the logging statement. As such, extending this approach to include the code succeeding the logging statement can improve on logging variable recommendation.

TABLE 8: Log printing statement automation research - Topic (E).

Reference - Aim	Experiments	Results	Pro	Con
Kim <i>et al.</i> [128] - Proposes an approach to verify the appropriateness of the log verbosity levels.	22 open-source projects from three different domains: <i>message queuing</i> , <i>big data</i> , and <i>web application server</i> .	Applies semantic and syntactic features and recommends a new log level in case the current level is deemed inappropriate. It reaches 77% precision and 75% recall in log level validation.	Creates <i>domain word model</i> from all of the log messages in application domains, which enables knowledge sharing between different projects.	In some cases, the appropriateness of log levels is dependent on developers' opinions and is quite arguable.
Gholamian and Ward [36] - Proposes a log-aware code clone detection (LACC) approach for log suggestions.	Three open-source Java projects: <i>Tomcat</i> , <i>Hadoop</i> , and <i>Hive</i> .	Performs an experimental study of logging characteristics of source code clones and observes that code clones match in their logging behavior. Achieves 90% accuracy in log location prediction.	It applies source code features and machine learning methods to detect log-aware code clones for log statement prediction.	The approach can only suggest logs for code snippets that can find their clone pairs in the software code base.
Li <i>et al.</i> [105] - Discusses the locations that need to be logged, and proposed a learning approach to provide code block level logging suggestions.	Seven open-source systems: <i>Cassandra</i> , <i>ElasticSearch</i> , <i>Flink</i> , <i>HBase</i> , <i>Kafka</i> , <i>Wicket</i> , and <i>ZooKeeper</i> .	The authors discover six categories of logging locations in different types of code blocks from developers' logging practices. It achieves balanced accuracy of 80.1% using syntactic source code features.	Utilizes a pipeline of word embedding, RNN layer, and a dropout layer in its deep learning model for log location prediction.	The achieves acceptable prediction by leveraging syntactic information only. Additional studies are required to combine syntactic and semantic features of the source code blocks.
Cândido <i>et al.</i> [92] - Proposes a log suggestion approach based on machine learning methods.	An enterprise software, Adyen, and 29 Apache projects.	The authors extract source code metrics from methods and evaluate the performance of five different learning approaches on log suggestions. The best performing model achieves 72% of balanced accuracy on Adyen's log statements set.	Performs a study on 29 Java projects and leveraged learning transfer to generalize to an industry project.	The applied transfer-learning approach shows a lower performance when trained on open-source projects and tested on Adyen enterprise project.
Li <i>et al.</i> [88] - Proposes a deep learning approach for log level prediction with an ordinal-based output layer.	Nine large-scale open-source projects: <i>Cassandra</i> , <i>ElasticSearch</i> , <i>Flink</i> , <i>HBase</i> , <i>JMeter</i> , <i>Kafka</i> , <i>Karaf</i> , <i>Wicket</i> , <i>ZooKeeper</i> .	The authors initially perform a manual study and categorize five different logging locations. The model trained with syntactic features achieves an average AUC of 80.8%.	Their findings infer that the log levels that fall far apart on the verbosity scale manifest different characteristics.	Log levels that are closer in order, <i>e.g.</i> , warn and error are more difficult to distinguish with this approach.

TABLE 8: Log printing statement automation research - Topic (E) (continued).

the quality of logs and save developers time.

**Learning to Log.** The idea of *learning to log* is to construct a machine learning (ML) model that can learn common logging practices and provide logging suggestions to the developers or directly make logging decisions and insert logging statements into a newly-developed source code snippet. A typical learning to log tool [30] is outlined in Figure 12. The log learning steps are: **1) code collection from repositories**, **2) labeling the collected source code**, **3) feature extraction and selection**, **4) feature vectors and model training**, and finally **5) logging enhancement, suggestion or automatic insertion**. Based on this platform, once the *training phase* is completed, during the *testing phase*, the learning model decides whether a new code snippet requires a logging statement by extracting its features and feeding it to the ML model, and observing the model's output. Learning algorithms apply a wide range of techniques such as: pattern or rule-based [1], [33], [66], [67], machine learning such as Naive Bayes, Bayes Net, Logistic Regression, SVM, and Decision Trees [30], Random Forrest [81], [92], Ordinal Regression [82], and most recently, Deep Learning [36], [88], [97], [105].

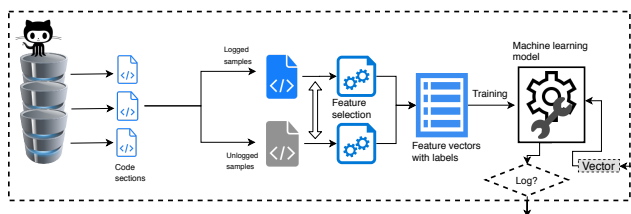

Fig. 12: Learning to log platform.

### 5.3.2 Source Code Feature Formulation

In order to be able to learn and predict log statements, prior research [30], [36] have proposed to define related source

code features and utilize them for predicting whether a code block requires a log statement. Source code features can be **structural** (type of the code blocks, *e.g.*, *catch clause*, *if-else*), **functional** (*e.g.*, metrics such as *code complexity*, *dependencies*, *fan-in*, and *fan-out*), **contextual** (*e.g.*, variables and keywords in the code snippet), and source code **semantic** features [105], [108], *i.e.*, *what the code snippet is trying to do*. What category of features to select and how well they can distinguish the logged and unlogged code snippet is an active research topic [30], [36], [105], [108], [162]. Additionally, the logging automation research has benefited from leveraging the findings in adjacent software tasks such as source code clone detection [163], and code commenting [164] for feature selection as the idea is that similar code snippets should follow similar logging patterns. Figure 13 shows a log prediction platform based on similar code snippets (*i.e.*, clone pairs), which are then later utilized for log prediction. Source code features are extracted from *method definitions* with logging statements. Then, once the machine learning model is trained and clone pairs are extracted, they are leveraged for log location prediction.

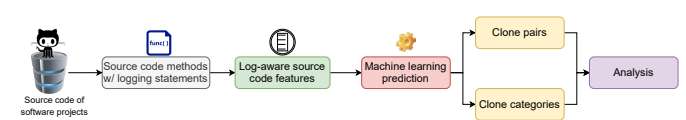

Fig. 13: Log prediction with source code features and code clones.

### 5.3.3 Automated Logging Categories

Figure 14 highlights the research in this area categorized into three subtopics: *log enhancement*, *log suggestion*, and *log*

*insertion*. These approaches are primarily concerned with log **location** prediction, *i.e.*, *where to log*, and secondarily the **content** to include in the logging statements, *i.e.*, *what to log*. Log enhancement aims to improve the quality of

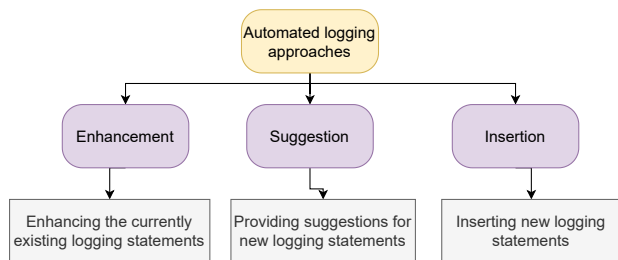

Fig. 14: Auto logging of the software systems’ source code.

existing logging statements, such as adding more runtime context [67]. Log suggestion aims to provide suggestions for logging locations that might have been missed, and log insertion aims to proactively insert logging statements into the source code [33]. Although the goals of these approaches are similar, the intended way of their implementation can be different. For example, one practical scenario of implementing log suggestion approaches is as IDE plugins that provide just-in-time suggestions [36]. However, the log insertion techniques are implemented as post-processing tools that scan the source code and insert logs for various criteria of interest, such as disambiguating execution paths [33] or logging catch clauses [66]. This categorization is not mutually exclusive and some of the prior work overlap in their approaches.

**Log Verbosity and Description Predictions.** In addition to predicting log location, prior research has also investigated approaches for prediction of the appropriate logging **verbosity level** for newly composed logging statements [51], [80], [82], [88], [141]. The approaches either apply some type of learning to predict the log verbosity level [141], or perform dynamic adjustment of the log level during the runtime [51]. Other research also aims to predict the description [107], or variables included in the logging statements [67], [97]. In Table 8, we compare and summarize the prior efforts in automated logging.

### 5.3.4 Evaluation Metrics

After training the learning model, its performance should be evaluated during the testing phase by applying new code instances as input and find out the prediction outcome that whether or not this new code snippet requires a logging statement, *e.g.*, Figure 12. This is an example of a *binary classification* problem [165]. Differently, Log verbosity level prediction is evaluated as a *multi-class classification* problem [166], as generally several verbosity levels are available for the log statements, *e.g.*, *WARN*, *INFO*, *DEBUG*, *etc.* Furthermore, ordinal multi-class classification [167] considers an order between the possible prediction labels. For example, for verbosity level prediction,  $WARN < INFO < DEBUG$ , such that  $WARN < INFO$  means *INFO* is more verbose than *WARN* [88]. Thus, different evaluation metrics are applied to assess the quality of learning models and their prediction accuracy. In general, the performance of a logging prediction method is evaluated by first extracting the confusion matrix.

		Model prediction	
		Positive	Negative
Actual (ground truth)	Positive	$TP$	$FN$
	Negative	$FP$	$TN$

TABLE 9: Confusion matrix for log prediction.

In Table 9, “*Model prediction*” values are from the learning model and the “*Actual*” values are the *ground truth*. Prior research often considers the developers’ inserted logging statements as *ground truth*. To create a set of training and testing data for the machine learning process and have a proper *ground truth* to compare with, one approach is to collect all of the code snippets with logging statements, and some samples of unlogged code, to include both positive and negative cases. Then, after deciding the train-test split and training the ML model, prior work removes the log statements from the test data. During the testing phase, the model’s performance is evaluated on the test code snippets with their logging statements being removed. This way we measure how well the model can **remember** which code snippets should have and which ones should not have logging statements, compared with the developers originally-inserted LPSs. Multiple iterations of the training-testing can be applied, *e.g.*, cross-validation [168], to confirm the results. From Table 9,  $TP$  means that the model correctly predicted a code snippet that requires a logging statement, and  $FN$  denotes that the model incorrectly predicted that a code snippet does not require a logging statement.

Based on the confusion matrix, we can define some of the common metrics for evaluating the performance of log learning models in Table 10. The definitions for *Precision* and *Recall* are straightforward. In order to ensure a prediction model benefits from equally good or comparable Precision and Recall values, *F-Measure* is defined as the harmonic mean of Precision and Recall. Qualitatively, good performance of *F-Measure* implies good performance on both Precision and Recall. *Accuracy* represents correctly identified logged instances to the total number of cases. *Balanced Accuracy (BA)* is the average of the proportion of logged instances and the proportion of unlogged instances that are correctly classified. In case there is an imbalance in the data, *e.g.*, in Table 9, if  $TN$  is much larger than  $TP$ , *Balanced Accuracy (BA)* is widely used to evaluate the modeling results [30], [81], [171], because it avoids the over-optimism that *accuracy* might experience. Receiver Operating Characteristic (ROC) plots *true positive rate* against *false positive rate*. AUC (area under the curve) is the area under the ROC curve. Intuitively, the AUC evaluates how well a learning method can distinguish logged code snippets and unlogged ones. The AUC ranges between 0 and 1. A high value for the AUC indicates a high discriminative ability of the learning model; an AUC of 0.5 indicates a performance that is no better than random guessing [81]. BLEU [169] and ROUGE [170] scores are equivalent to Precision and Recall and are leveraged to evaluate the auto-generated text compared to the original text developed by developers. These scores have applications in evaluating the auto-generated log statement descriptions (LSDs), which are sequences of tokens, *i.e.*, words. For example, for a candidate LSD,  $C$  and the reference LSD,  $R$ , BLEU measures the ratio



Metric	Formula	Description
Precision	$\frac{TP}{TP+FP}$	The ratio of correctly identified positive instances to the number of all positive predictions.
Recall (a.k.a. <i>sensitivity, hit rate, and true positive rate</i> )	$\frac{TP}{TP+FN}$	The ratio of the correctly predicted instances to the number of existing positive instances.
False Negative Rate	$\frac{FN}{FN+TP}$	The ratio of false negatives to the total number of existing positive instances.
True Positive Rate	$\frac{TP}{TP+FN}$	The ratio of true positives to the total number of existing positive instances.
True Negative Rate (a.k.a. <i>specificity, and selectivity</i> )	$\frac{TN}{TN+FP}$	The ratio of true negative to the total number of existing negative instances.
False Positive Rate (a.k.a. <i>fall-out</i> )	$\frac{FP}{FP+TN}$	The ratio of false positives to the total number of existing negative instances.
F-Measure (a.k.a. <i>F-Score, F1-Score</i> )	$\frac{2 \times Precision \times Recall}{Precision + Recall}$	Harmonic mean of Precision and Recall.
Accuracy	$\frac{TP+TN}{TP+TN+FP+FN}$	Accuracy is the proportion of correctly identified logged instances to the total number of cases.
Balanced Accuracy (BA)	$\frac{1}{2} \times \left( \frac{TP}{TP+FP} + \frac{TN}{TN+FN} \right)$	Balanced accuracy (BA) is the average of the proportion of logged instances and the proportion of unlogged instances that are correctly classified.
Receiver Operating Characteristic curve (ROC)	$\frac{TPR}{FPR}$	The plot of the true positive rate against the false positive rate.
Area Under Curve	$area_{under}(ROC)$	<i>Area under the curve</i> is the area under the Receiver Operating Characteristic curve.
BLEU (BiLingual Evaluation Understudy)	$\frac{count\_tokens(C \cap R)}{count\_tokens(C)}$ *	Similar to Precision but for auto-generated text. The ratio of the candidate tokens (C) that exist in reference tokens (R) over the total candidate tokens.
ROUGE (Recall-Oriented Understudy for Gisting Evaluation)	$\frac{count\_tokens(C \cap R)}{count\_tokens(R)}$ *	Similar to Recall but for auto-generated text. The ratio of the reference tokens that exist in the candidate tokens over the total reference tokens.

\* Simplified formulas are presented. There is also weight corresponding to the size of n-grams that comes in the general formula for BLEU [169]. Similarly, for ROUGE, refer to [170].

TABLE 10: Evaluation metrics for automated log prediction.

of tokens of  $C$  that also appear in  $R$  (analogous to Precision), and ROUGE measures the ratio of tokens of  $R$  that have appeared in  $C$  (analogous to Recall). The range of values for BLEU and ROUGE is  $[0,1]$ , with 1 being the perfect score. These two measures combined explain the quality of the auto-generated LSDs.

**Examples of Metrics Used.** Li *et al.* [158] utilized *Precision* and *Recall* to calculate the performance of *DLFinder* in detecting logging code smells. Zhu *et al.* [30] used *BA* to evaluate the accuracy of *LogAdvisor*, which advises the developer if logging statements are required for a focused code snippet. Li *et al.* [27], [81], [82] used *ROC* and *AUC* to evaluate their methods in *log verbosity level prediction* and *logging commit change suggestion*. Kim *et al.* [128] used *F-Measure* to evaluate their log verbosity level recommendation approach, and Gholamian and Ward [36] utilized *Accuracy* to evaluate the performance of their log-aware clone detection approach. He *et al.* [107] leveraged BLEU and ROUGE scores to evaluate the effectiveness of the candidate log statement descriptions when compared to the developer-inserted log

descriptions.

## 5.4 Mining Log Files

Priorly, we mentioned the purpose of logging statements added by developers is to expose valuable runtime information. The output of logging statements is written to log files, which are used by a plethora of log processing tools to assist developers and practitioners in different tasks such as software debugging and testing [3], [172], performance monitoring [142], and postmortem failure detection and diagnosis [6], [7], [8], [112]. We review log mining techniques and approaches in the following.

### 5.4.1 Category F: Log Maintenance and Management

As the size of logs increases, the job of methods and tools which manage and maintain logs becomes more crucial, cumbersome, and of value. For example, FLAP [134] provides an end-to-end platform for log collection, maintenance, and analysis. In the following, we review *log collections*, *log compression*, *log rolling*, and *log removal*, and Table 11 summarizes the research in this category.

**Log Collections.** The aim of maintaining a log collection is for auditing [173] or enabling benchmarking for different types of log analysis [101], [102], [103]. For example, Loghub [124] provides a repository of logs from various software systems, and Cotroneo *et al.* [174] have released an OpenStack failure dataset containing injected faults. The logs are used in various prior works for evaluating tasks such as compression techniques [83], [175], failure analysis [6], [103], [112] and bug detection [176]. We observe that although execution logs of different systems are conveniently available, it is difficult to find large-scale collections of labeled datasets, which are especially crucial for supervised learning of log mining tasks [2]. This is because manually labeling large datasets of logs is quite cumbersome. Thus, we see significant value in curating a database of labeled logs (*e.g.*, normal vs. anomaly/failure log records), and the development of automated log labeling techniques [89].

**Log Compression.** With the continued growth of large-scale software systems, they tend to generate larger volumes of log data every single day, which makes the analysis of logs challenging. As such, to cope and contain this challenge, developers and practitioners apply tools for compression and continuous archiving of logs [56], [83]. Hassan *et al.* [177] applied log compression to extract common usage scenarios. Yao *et al.* [83] studied the performance of general compressors on compressing log data relative to their performance on compressing natural language data. Their work reviews 12 widely used general compressors to compress nine log files collected from various software systems. Because log files generally benefit from higher repetition than natural text [83], there is an avenue of outstanding work to develop log-aware compression techniques, that consider log characteristics in their algorithms and their parameter selections and achieve a higher compression/decompression performance.

**Log Rolling.** As log data generally grows rapidly during the system's execution [83], [178], logging libraries such as Logback [179], Log4j/2 [31], and SELF4J [49] often support

Reference - Aim	Experiments	Results	Pro	Con
Li <i>et al.</i> [126] - Proposes a data-driven management framework by knowledge acquisition from historical log data.	Log files collected from several Windows machines in a university network.	Performs experiments on categorizing dependent and independent log events, and applies text mining techniques to categorize log messages, mines temporal data, and performs event summarization.	Provides a graphical representation of temporal relationship among events as an event relationship network (ERN) [181].	Common categories of log messages are manually determined, which can be automated from historical data.
Marty [122] - Proposes a proactive logging guideline to support forensic analysis in cloud environments.	N/A (the research does not provide experimentation).	Discusses the challenges of logging in the cloud environments such as <i>decentralization</i> and <i>volatility</i> of logs.	Outlines the guidelines for when the logging is required: <i>business relevant, operational, security, compliance</i> .	The guideline can be expanded to include forensic timeline analysis of logs, log review, and log correlation.
Li <i>et al.</i> [134] - Introduces FLAP, a web-based integrated system to utilize data mining techniques for log analysis and knowledge discovery.	Network X event logs at Huawei Technologies.	Performs a case study and the results show the approach's applicability for different tasks, such as event summarization (graph) and root cause analysis.	It provides learning-based log event extraction and provides event summarization and visualization.	Some of the tasks, <i>e.g.</i> , root cause mining, rely on domain knowledge to manually diagnose possible problems.
Liu <i>et al.</i> [56] - Proposes a new log compression method, logzip, to allow for more effective log compression.	Five log datasets: <i>HDFS, Spark, Windows, Android, and Thunderbird</i> .	Achieves higher log compression ratios compared to general-purpose compressors, <i>e.g.</i> , <i>bzip2</i> , and can generate compressed files around half of the size of general-purpose compressors.	Performs iterative clustering with template extraction and parameter mapping and can compress in three incremental levels: L1: <i>field extraction</i> , L2: <i>template extraction</i> , and L3: <i>parameter mapping</i> .	The performance of the de-compression should be also evaluated and compared with other compressors.
Yao <i>et al.</i> [83] - Studies the performance of general compressors on compressing log data relative to their performance on compressing natural language data.	Nine system logs, such as <i>HDFS</i> and <i>LinuxSyslogs</i> , and two natural language (NL) data, <i>Wiki</i> and <i>Gutenberg</i> .	Reviews twelve widely used general compressors to compress nine log files collected from various software systems. The observation is that log data is more repetitive than natural language, and log data can be compressed and decompressed faster than NL with higher compression ratios.	One of the findings is that general compressors perform better on small log sizes, and their default compression level is not optimal for log data.	The findings and implications of this research have not been utilized to propose a log-aware compressor.
Shin <i>et al.</i> [123] - Introduces <i>LogCleaner</i> , which performs periodicity and dependency analyses for removing repetitive logs.	Two proprietary and eleven publicly available log datasets including: <i>CVS, RapidMiner</i> .	The approach can accurately detect and remove 98% of the operational messages and preserve 81% of the transactional log messages, and reduces the execution time of the <i>model inference</i> task from logs.	Segregates and only keeps transactional messages, which record the functional behavior of the system from operational messages of the system.	The performance of <i>LogCleaner</i> is heavily dependent on the quality of upstream log parser and template extraction, and requires manual analysis and domain knowledge.
He <i>et al.</i> [124] - Provides a repository, <i>Loghub</i> , of logs from various software systems.	Provides 17 log datasets from various application domains, including <i>distributed systems, supercomputers, and operating systems</i> .	Provides a framework for AI-powered log analysis and applies a practical usage scenario of <i>Loghub</i> for anomaly detection for supervised and unsupervised approaches.	<i>Loghub</i> datasets have been widely utilized for research both in academia and industry.	There is still a shortage of labeled datasets to facilitate the evaluation of supervised log analysis tasks.
Chen and Jiang [65] - Performs a survey on log instrumentation techniques.	N/A (the research does not provide experimentation).	Focuses on the three log instrumentation steps: <i>logging approaches, logging utility integration, and logging code composition</i> .	Defines four categories of challenges for instrumentation: <i>usability, diagnosability, logging code quality, and security compliance</i> .	The research can be improved by providing a connection between <i>logging source code</i> and its corresponding <i>log messages</i> in the <i>log files</i> .
Locke <i>et al.</i> [95] - Proposes <i>LogAssist</i> to assist practitioners with organizing and summarizing logs.	Logs from one enterprise (ES) and two open source systems: <i>HDFS</i> and <i>ZooKeeper</i> .	Groups logs into event sequences to extract workflows and illustrate the system's runtime execution paths. <i>LogAssist</i> shrinks the log events by 75.2% to 93.9% and the unique workflow types by 70.2% to 89.8 in <i>HDFS</i> and <i>ZooKeeper</i> logs.	<i>LogAssist</i> is able to reduce the number of log events of interest to practitioners, thus it saves time and improves the practitioners' experience in log analysis.	In some cases, the searched keywords ( <i>e.g.</i> , "error" or "exception") for finding problematic log lines result in a large quantity of logs for practitioners to manually review.

TABLE 11: Log maintenance and management research - Topic (F).

the continuous rolling *i.e.*, archiving of log files as new logs become available. For example, as the size of the generated log goes beyond a user-defined value on the storage or a specific time interval has passed (*e.g.*, daily, weekly), a *Log4j Appender* [180] can zip, rename, and store the log with a timestamp, *e.g.*, "logs/app-%dMM-dd-yyyy.log.gz". Log archiving helps with the long-term maintenance and organization of logs. There is certainly room for further research on improving and automating log archiving policies and techniques.

**Log Removal.** Although logs are useful, but due to the large volume of them, they can become noisy, hard

to analyze, and cause inaccuracy in log analysis. As such, prior research has aimed to detect and remove duplicate log messages [123], [182], [183]. For example, Shin *et al.* [123] introduced *LogCleaner*, which performs *periodicity* and *dependency* analyses to filter out and remove periodic and dependent log messages. In sum, the approaches that are applied for log maintenance and management facilitate automated analysis of logs, and furthermore, will yield more accurate log analysis.

### 5.4.2 Automated Log File Analysis - Challenges and Motivation

Logs record system runtime information and are widely used and examined for assessing the systems' health and availability [161]. Traditionally, developers or operators often inspect the logs manually with keyword searches (e.g., "fail", "exception") and rule matching (e.g., "*grep <Regex>*") to find any potential problems in case of a system failure. However, manual or keyword inspection of log files becomes impractical with the ever-increasing complication of software systems because of the following reasons [161]:

- ① As current computer systems generate a massive volume of logs, e.g., at the rate of 50 gigabytes per hour (around 120~200 million log lines) on Alibaba Cloud Computing Mailing System (Aliyun Mail) [184], this makes it close to impossible to manually extract useful information from the log files and track down any system issues.
- ② The complex and concurrent nature of software systems makes it unmanageable for a single developer to comprehend the entire functionality of the system, as a single developer might be only responsible for the development of a small sub-module of the entire project. For example, hundreds of developers take part in the development of parallel computing platforms, such as Apache Spark [52]; thus makes it quite challenging, if not impossible, for a single developer to pin down an issue from concurrent and massive log files.
- ③ Parallel and distributed software systems generally apply various methods of fault-tolerant and performance optimization techniques in order to recover from a hardware failure or perform load-balancing and scheduling. For example, a resource manager daemon, e.g., on a Hadoop or Spark cluster, may intentionally terminate a running application and move it to another node in the system in order to expedite the execution of that task. As a result, the traditional and manual way of searching in the log files for keywords such as *killed*, *terminated*, *failure* might not be useful and can lead to multiple false-positive cases [185] and further muddle the manual inspection.

Moreover, although automatic log analysis helps developers and practitioners significantly to speed up the process (e.g., [9], [104], [112]), the automatic log analysis itself is still very challenging because log messages are usually unstructured free-form text strings, and application behaviors are often very heterogeneous and complicated [4]. As a result, effective automated log analysis methods are well sought after. To enable automatic log analysis, the very first step is **log parsing**, **Category G**, followed by applications of automated log analysis, i.e., **anomaly detection**, **Category H**, **runtime behavior**, **Category I**, and **performance, failure, and fault diagnosis**, **Category J**, that we review in the following.

#### 5.4.3 Category G: Log Parsing

Log parsing is the process of converting the free-form text format of log files to structured events. Figure 15 provides an example of a raw log message from a log file that

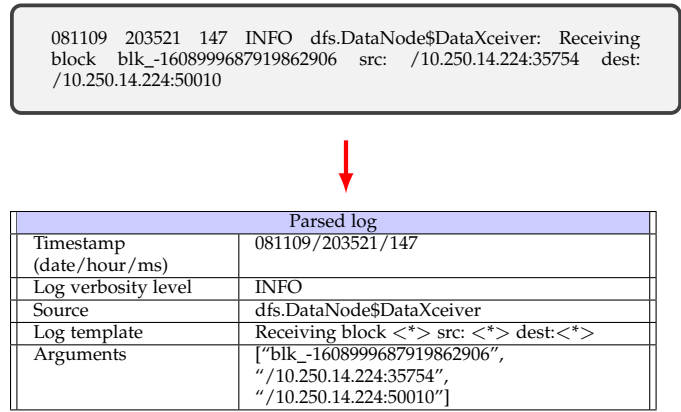

Fig. 15: Log parsing for a raw log message to a parsed log from HDFS logs [2].

is parsed to its individual elements. Each log message is printed by a logging statement in the source code, which records a specific system event. Then, a log parser applies techniques to convert the free-form text format of the log messages to a structured format, as presented in Figure 15. More specifically, the log parser can extract useful information, such as timestamp, log verbosity level, variable arguments, and log template. The goal of the log parser is to convert each log message to a specific log template (e.g., Received block (\*) src: (\*) dest: (\*) in Figure 15). Ideally, there is a corresponding logging statement in the source code for each extracted log template, e.g., *log.info("Received block %s src: %s dest: %s", obj.blk\_id, obj.src, obj.dest)*. The better the log parser can match the log templates with actual log printing statements in the source code, the merrier the quality of log parsing, and consequently, the more accurate log analysis tasks that follow.

Log parsing, traditionally, started with defining manual regular expressions to extract log templates and arguments. However, this approach alone is no longer efficient due to the huge number of log templates as well as their continuous evolution [54]. For example, Xu *et al.* [2] explained that in a Google's system, on average, thousands of new logging statements are added every month. Therefore, automating the log parsing process is very well obliged. Some studies have also proposed, as an alternative, the use of static methods to curate the software's source code and extract log patterns directly from the logging statements within the source code [2], [189]. These approaches are only useful if the source code of the system is available. To extend the application of log parsing to the scenarios that the source code is not available, e.g., proprietary software, other studies have proposed various data mining approaches to extract log templates from the log files instead, such as frequent pattern mining in SLCT [46] and its extension, LogCluster [13], iterative partitioning in IPLoM [12], clustering in LKE [4], longest common subsequence in Spell [87], search-space multi-objective optimization approach in MoLFI [140], parsing trees in Drain [139], and n-gram dictionary-based in Logram [96]. Contrary to the regular-expression-based and static analysis methods, these techniques are capable of extracting log templates from log files without needing access to the source code. After the logs are parsed, they are

Reference - Aim	Experiments	Results	Pro	Con
Qiu [135] <i>et al.</i> - Designs <i>SyslogDigest</i> that extracts log events from the router's syslogs.	Syslog data from two large operational networks: a tier-1 ISP backbone network and a nationwide commercial IPTV backbone network.	It combines an <i>offline</i> and <i>online</i> domain knowledge learning components automatically extracts relevant domain knowledge from raw syslog data. The authors showcase the applications in network <i>troubleshooting</i> , and <i>health monitoring and visualization</i> .	Applies associated rule mining, then transforms and compresses low-level raw syslog messages into their prioritized high-level events.	The work is limited only to event template extraction from a specific system, <i>i.e.</i> , syslog messages.
Taerat <i>et al.</i> [131] - Introduces <i>Baler</i> , a token-based log parsing tool.	Logs of four supercomputers: <i>BG/L</i> , <i>Liberty</i> , <i>Spirit</i> , and <i>Tbird</i> .	For clustering, <i>Baler</i> relies on token attributes rather than frequency or entropy of token positions that are applied in other log parsers. <i>Baler</i> handles large datasets better than compared tools and more efficiently, <i>i.e.</i> , faster execution time.	Requires only one pass to cluster log messages based on their event templates.	<i>Baler</i> relies on the user to provide a dictionary of words.
Tang <i>et al.</i> [133] - Proposes <i>LogSig</i> , message signature based algorithm to generate events from textual log messages.	Logs of five real-world systems, including <i>FileZilla</i> , <i>PVFS2</i> , and <i>Hadoop</i> .	It searches for the most frequent message signatures and then categorizes them into a set of event types. <i>LogSig</i> performs better in the <i>quality of the generated log events</i> (F-Measure) and <i>scalability</i> when compared to prior work.	<i>LogSig</i> converts each log line into a set of ordered token pairs and then partitions log messages into $k$ different groups based on the extracted term pairs.	<i>LogSig</i> has a prolonged execution time on large log datasets and reaches low accuracy on the BGL data [186].
Vaarandi <i>et al.</i> [13] - Presents <i>LogCluster</i> , a data clustering and pattern mining algorithm for textual log lines.	A set of six system logs from a large national institution, including database systems, mail servers, and firewall logs.	<i>LogCluster</i> improves SLCT [46] such that each Cluster $C_i$ is uniquely identified by its pattern $P_i$ , and each pattern consists of words and wildcards, which makes it insensitive to word shifts. <i>LogCluster</i> performs more accurate clustering and finds fewer groups compared to SLCT.	The <i>support</i> of a cluster is calculated as the number of elements in that cluster: $supp(p_i) = supp(C_i) =  C_i $ . Finally, clusters with support of equal or higher than a threshold value, $s$ , are selected.	The algorithm requires a two-pass process to categorize the list of frequent patterns.
Du <i>et al.</i> [87] - Proposes <i>Spell</i> , an online log parsing method based on longest common subsequence (LCS).	Two supercomputer logs: <i>Los Alamos HPC log</i> and <i>BlueGene/L log</i> .	Parses unstructured log messages into structured events types and parameters in an unsupervised streaming fashion with linear time complexity. <i>Spell</i> with pre-filtering has a faster computation time and achieves a higher accuracy compared to prior work.	The LCS approach achieves a faster template searching process by enabling subsequent matching and prefix trees.	The prefix tree depth can grow arbitrarily without limitation, which can lead to lengthy computation time on large datasets.
He <i>et al.</i> [139] - Proposes <i>Drain</i> , a fixed-depth tree-based online log parsing method.	Five real-world data sets: <i>BGL</i> , <i>HPC</i> , <i>HDFS</i> , <i>Zookeeper</i> , and <i>Proxifier</i> .	Constructs a tree data structure and groups the logs that belong to similar log events ( <i>i.e.</i> , templates) into the same <i>leaf node</i> of the tree. The approach achieves higher or equal accuracy and obtains 51.85% to 81.47% faster runtime compared to other online log parsers.	<i>Drain</i> is specifically useful for web services as it enables log parsing in a streaming manner, and evaluation shows that <i>Drain</i> outperforms prior offline and online log parsing approaches.	It appears that <i>Drain</i> does not fully handle positional shifts in the log templates, and log messages that belong to the same log event but have different lengths will be grouped separately.
Messaoudi <i>et al.</i> [140] - Introduces <i>MoLFI</i> (Multi-objective Log message Format Identification), which leverages an evolutionary algorithm for log message format identification.	Six real-world datasets: <i>HDFS</i> , <i>BGL</i> , <i>HPC</i> , <i>Zookeeper</i> , <i>Proxifier</i> , and one industrial software logs.	<i>MoLFI</i> achieves a higher performance than the compared alternative algorithms in detecting the correct log message templates.	Formulates the log template identification task as a <i>multi-objective optimization problem</i> and propose a search-based solution based on the NSGA-II algorithm [187], <i>i.e.</i> , a sorting genetic algorithm.	<i>MoLFI</i> suffers from low efficiency ( <i>i.e.</i> , high execution time) on large datasets as its iterative genetic algorithm, NSGA-II, is computationally intensive [54], [188].
Dia [96] - Introduces <i>Logram</i> , which uses <i>n-grams dictionaries</i> to perform log parsing. <i>Logram</i> initially calculates the number of appearance of each <i>n-gram</i> ( <i>i.e.</i> , token) in the log file.	Eventuated on 16 publicly available logs including <i>Android</i> , <i>BGL</i> , <i>HDFS</i> , <i>Spark</i> , and <i>Zookeeper</i> logs.	Achieves a higher parsing accuracy than the prior work, and it is 1.8X to 5.1X faster than in its calculation when compared to prior work.	Based on the threshold of an <i>n-gram</i> occurrence, <i>Logram</i> decides dynamic and static parts of the log messages and extracts the log templates.	One caveat for this log parser is the threshold selection for <i>n-gram</i> appearance, and if a dynamic <i>n-gram</i> occurs frequently, it might be mistakenly picked as a part of the log template.

TABLE 12: Log parsing research - Topic (G).

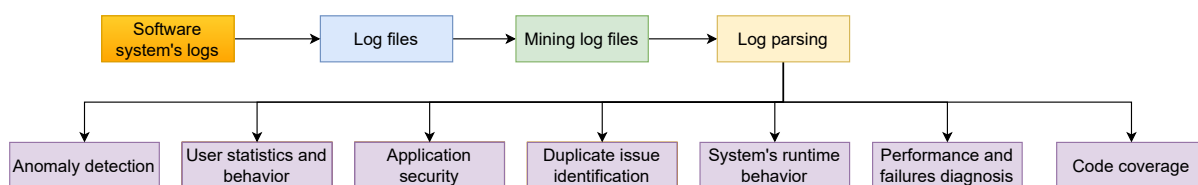

Fig. 16: Mining of log files for different applications.

used for various applications, such as anomaly detection and failure diagnosis. Zhu et al. [54] presented a log parsing benchmark available here [190], and El-Masri *et al.* [188] performed a survey of log abstraction techniques. Table 12 summarizes log parsing research and Figure 16 categorizes various trends and goals for log file analysis after log parsing is applied.

#### 5.4.4 Category H: Anomaly Detection

Execution logs are extensively leveraged to monitor the health of software systems, identify abnormal situations, and detect anomalies that can lead to system failures. Anomaly detection methods include various approaches, such as: ① creating a state machine of normal execution and comparing the failure runs with normal models [3], [4], ② PCA-based approach which projects event logs to normal and abnormal subspaces [2], ③ deep learning approaches which learn an LSTM model from normal execution workflows [5], and unstable logs [104], ④ semi-supervised deep learning approaches with probabilistic label estimation [89], ⑤ a statistical approach using probabilistic suffix trees [100], and ⑥ cloud deployment by correlating logs and resource metrics [101]. As a reference for further reading, He *et al.* [161] performed a quantitative comparison of various log-based anomaly detection approaches. Table 13 provides a detailed comparison and *pros* and *cons* of various research for anomaly detection with logs.

#### 5.4.5 Category I: System's Runtime Behavior

Researchers have also utilized logs for monitoring the system's runtime behavior. Some of the research overlaps with approaches for 'anomaly detection' and 'performance and failure diagnosis'. These approaches include: ① using logs to customize operational profiles for industry software [177], ② web service composition [137], ③ detecting inter-component interaction [113], ④ mining system events correlation [118], [125], ⑤ assisting developers in cloud deployments [90], ⑥ performance model derivation [136], ⑦ big-data analytics for cloud deployment [90], and ⑧ detecting impactful system problems [103]. We provide further comparison for this research category in Table 14.

#### 5.4.6 Category J: Performance and Failure Diagnosis

In many cases, log messages are one of the most important clues and often the only available resource for the system's failure diagnosis and performance degradation, as it might be difficult and undeterministic to reproduce a failed scenario by replaying (*i.e.*, rerunning). Developers often have to diagnose a production run performance degradation or failure based on logs collected in the field and returned by customers without having access to the infield user's inputs. Performance and failure diagnosis approaches include: ① probable program execution paths investigation with logs [6], ② machine learning to compare and classify logs with good and bad performance [7], ③ correlating performance counters (*e.g.*, CPU/memory usage) and logs [8], ④ automaton-based workflow modeling [111], ⑤ process-oriented dependability analysis [112], ⑥ control and data flow analyses to extrapolate causal relations among logs [9], [10], [109], and ⑦ fault diagnosis with

logs [129]. Table 15 summarizes the research on mining of log files for performance and failure diagnosis.

#### 5.4.7 Category K: User, Business, Security, and Code Coverage

Other applications of log file mining include: **analyzing user statistics and behavior** [15], **application security** [114], **duplicate issue identification** [86], **code coverage with logging statements** [106], and **business analytics** [14]. For example, Figure 17 shows how recurrent issues are first classified through historical log records, and once a new record is available, it is analyzed and compared against the historical issues [86]. Table 16 further explains each research effort.

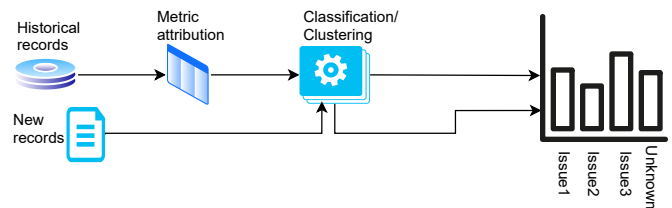

Fig. 17: Duplicate and recurrent issue detection tool.

#### 5.4.8 Implementation and Evaluation

It is worth mentioning that many of the concepts with regards to feature selection, machine learning implementation, and evaluation metrics that are utilized for designing and assessing the log statement automation approaches (Sections 5.3.1-5.3.4) are also leveraged for designing and evaluating log file mining tasks. For example, *DeepLog* [5], proposes a machine learning algorithm for log file mining. *LogRobust* [104] extracts feature vectors from the log files and implements an LSTM deep learning approach, and evaluates its anomaly detection approach with *Precision*, *Recall*, and *F-Measure*. *Drain* [139], a log parsing tool, evaluates its performance with *F-Measure*.

### 5.5 Category L: Emerging Applications of Logs

Thus far, we discussed different logging practices and log applications, mainly in large-scale software systems. However, most recently, there has been a special interest in applications of logs in other domains such as mobile devices [84], [85], embedded [203], [204], [205], and big data [57], [102], [146]. We summarize the key findings here:

- Prior studies have proposed the application of logs for emerging areas such as **mobile** and **big data systems**.
- For **mobile**, developers should be aware of different logging practices that might apply to alternative platforms with different design criteria and requirements. For example, because mobile devices operate on battery with limited storage space, the cost and overhead of logging (*e.g.*, continuously flushing logs) become more exorbitant and unfavorable than software that is running on a workstation.
- Developers of log analysis tools have considered **big-data platforms** to scale and speed up log analysis.
- **Natural language attributes** of logs [93], [107] open up a new avenue for log statement automation, *e.g.*, log

Reference - Aim	Experiments	Results	Pro	Con
Xu <i>et al.</i> [2] - Applies the Principal Component Analysis (PCA) method to find unusual patterns in logs and identifies log segments that are likely to indicate runtime anomalies and system problems.	Logs of the <i>Darkstar online game server</i> and <i>HDFS</i> .	PCA extracts $k$ principal components by finding the axes with the highest variance among high-dimensional data. The approach can detect anomalous logs with high accuracy and few false positives while being efficient in its computation time.	For anomaly detection with PCA, two subspaces, <i>i.e.</i> , normal, $S_n$ , and abnormal, $S_a$ , are created. $S_n$ is created with the first $k$ principal components, and $S_a$ is constructed with the remaining components.	Relies heavily on log parsing step to extract log structure from the logs and detect event sequences, and will fail if log messages do not follow the preferred structure.
Fu <i>et al.</i> [4] - Introduces a method to detect anomalies by converting unstructured log files to log keys.	Two distributed systems: <i>Hadoop</i> and <i>SILK</i> .	The research learns a finite state automaton (FSA) from the training set log keys to model the normal behavior of the system. The results show that the approach can detect system issues, such as workflow errors.	With the FSA and a performance model, the authors can identify anomalies in newly generated log files. The work detects three types of anomalies: 1) <i>work flow error</i> , 2) <i>transition time low performance</i> , and 3) <i>loop low performance</i> .	The approach does not work properly for <i>loop low performance</i> detection, results in false positives, and it is workload dependent.
Lou <i>et al.</i> [116] - Proposes an approach to detect anomalies by mining program invariants (IM) that have a clear physical manifestation.	Experiments on <i>Hadoop</i> and <i>Microsoft CloudDB</i> .	It detects anomalies if the new logs break certain invariants, <i>e.g.</i> , if an "open file" log message appears without observing a "close file", this invariant is violated and an anomaly is detected. Generally, produces fewer false-positive cases compared to the PCA-based approach.	Improved upon the PCA-based method [2], this approach provides the operators with intuitive insight ( <i>i.e.</i> , what invariant is breached) on anomalies, and, hence, facilitate faster anomaly track down.	This approach is not able to detect anomalies that no invariant is broken, <i>e.g.</i> , many files are opened and closed continuously.
Chuah <i>et al.</i> [121] - Presents <i>ANCOR</i> that connects resource usage anomalies with system problems with logs.	<i>Ranger</i> supercomputer logs in two formats: <i>syslogs</i> and <i>ratlogs</i> (rationalized logs) [191].	Evaluates the effectiveness of three different algorithms, <i>PCA</i> , <i>ICA</i> , and <i>Mahalanobis distance</i> . The results reveal a list of events with a strong correlation with system problems, such as <i>soft lockup</i> .	Performs anomaly and correlation analyses to detect the cluster nodes and jobs that are associated with the extra system resource usage that lead to system failures.	The approach cannot detect system problems that are not manifested as extra resource usage.
Du <i>et al.</i> [5] - Presents <i>DeepLog</i> , an online LSTM-based approach, to model system log files as natural language sequences.	<i>HDSF</i> and <i>OpenStack</i> log datasets.	<i>DeepLog</i> decodes the log message, including timestamp, log key, and parameter values, and applies both <i>deep learning</i> and <i>density clustering</i> approaches. The approach outperforms <i>PCA</i> and <i>IM</i> methods and produces a lower number of false-positive and false-negative cases.	Learns log patterns from the normal execution and constructs workflows, and detects anomalies when running log patterns deviate from the normal execution.	<i>DeepLog</i> is evaluated on systems with highly regulated logs and with a limited log key space, <i>i.e.</i> , <i>Hadoop</i> (29 keys) and <i>OpenStack</i> (40 key) [192].
Bertero <i>et al.</i> [17] - Leverages natural language processing techniques for anomaly detection.	660 <i>syslog</i> log files, half of them (330 files) for normal system executions, and the other half are abnormal runs.	Explores the performance of three learning classifiers, <i>i.e.</i> , <i>Naive Bayes</i> , <i>Random Forest</i> (RF), and <i>Neural Networks</i> , and evaluates their performance on predicting normal versus stressed ( <i>i.e.</i> , abnormal) log files. RF has the best performance.	Applies a word embedding technique, <i>i.e.</i> , <i>word2vec</i> , to map log message words to metric space, and then utilizes machine learning classifiers to summarize log files to single points.	The approach is limited to supervised learning and requires the pre-labeling of log files.
Bao <i>et al.</i> [100] - Utilizes both the source code analysis and the log file mining for anomaly detection.	<i>CloudStack</i> and <i>HDFS</i> logs.	It presents a probabilistic suffix tree-based statistical approach to detect anomalies from console logs. The results show the proposed approach can detect the largest number of anomalies compared to prior work.	The source code analysis employs control flow and log statement analysis to extract "schema" for the subsequent log parsing stage.	For feature extraction, the approach only takes into consideration the number of occurrences of an event and does not consider the sequential relationship of the traces.
Farshchi <i>et al.</i> [101], [193] - Proposes a regression-based statistical approach to correlate operation behavior with cloud metrics.	Experiments on <i>Amazon Web Services</i> (AWS) logs.	For anomaly evaluation, the work injects faults in 22 iterations of a rolling upgrade task and utilizes the learned model for fault prediction. Two-minute-time-window (2 mTW) metric observation prior to the anomaly achieves the highest F-Measure.	The authors utilize a regression-based method to detect the most statistically significant metrics for anomaly detection and observe cloud metrics changes and signal anomalies in case of divergence.	The evaluation is performed with synthetically injected faults. Further evaluation on actual system faults can help to better validate the approach.
Meng <i>et al.</i> [132] - Proposes <i>LogAnomaly</i> , an approach to model log messages as natural language sequences for anomaly detection.	Two datasets: <i>BGL</i> and <i>HDFS</i> .	<i>LogAnomaly</i> achieves a better F1-Score (0.96 on <i>BGL</i> and 0.95 on <i>HDFS</i> ) compared to <i>DeepLog</i> (0.90 on <i>BGL</i> and 0.88 on <i>HDFS</i> ).	It leverages a new word embedding approach, <i>template2Vec</i> , to model the sequential and quantitative patterns of logs and extract the semantic information of log templates.	The approach does not take into account the runtime parameter values.
Zhang <i>et al.</i> [104] - Proposes a log-based anomaly detection approach, <i>LogRobust</i> , which can handle unstable log lines.	Real and synthetic <i>HDFS</i> log data, and <i>Service X</i> logs from <i>Microsoft</i> .	It extracts semantic information of log events as semantic vectors. <i>LogRobust</i> achieves the highest F-Measure in detecting anomalous log lines in unstable datasets, and the performance decreases as the unstable logs change further ( <i>i.e.</i> , become more unstable).	It can identify new but semantically similar log events that emerge from logging evolution and processing noise.	If there are drastic and significant changes to the entire code base or logging mechanism, the <i>LogRobust</i> would perform poorly in anomaly detection.

TABLE 13: Log anomaly detection research - Topic (H).

Reference - Aim	Experiments	Results	Pro	Con
Zhang <i>et al.</i> [119] - Proposes Anomaly Detection by workflow Relations (ADR).	BGL and HDFS logs.	The approach mines numerical relations from logs and uses the relations for anomaly detection. ADR detects a higher number of relations in less time compared to the invariant mining (IM) approach.	For faster online anomaly detection, ADR leverages an optimization approach, Particle Swarm Optimization (PSO) [194], to find the proper window size to split the log entries.	The experimentation is performed on highly regulated logs with a low number of log keys ( <i>i.e.</i> , Hadoop and BGL), and for BGL data, simpler approaches, <i>e.g.</i> , SVM, outperform ADR.
Huang <i>et al.</i> [127] - Proposes <i>HitAnomaly</i> , that is a transformer-based [195] log anomaly detection method.	Three system logs: <i>HDFS</i> , <i>BGL</i> , and <i>OpenStack</i> .	The approach achieves F1-Scores higher than prior work for stable logs, and for unstable logs performs best under 10% instability injection into the log lines.	The approach allows to capture the semantic information in both log template sequence and parameter values and provides an attention-based classifier for log anomaly detection.	<i>HitAnomaly</i> 's performance drops lower than <i>LogRobust</i> [104] for higher rates of instability in log sequences.
Zhou <i>et al.</i> [138] - Proposes <i>LogSayer</i> , a log-based anomaly detection approach with pattern extraction for cloud environment.	One <i>HDFS</i> log set and two <i>OpenStack</i> log data sets.	The key observation is that different components of cloud systems show different levels of system resource usage during anomalous behavior. The approach performs the best in detecting transient anomalies with an accuracy of 93% and outperforms <i>DeepLog</i> [5] and <i>CloudSeer</i> [111].	Applies a back-propagation (BP) LSTM-based approach to learn and correlate the historical logs with current logs, and deviations are signaled as potential anomalies.	<i>LogSayer</i> 's performance is dependent on the <i>time window</i> size, and its performance towards unstable logs [104] is not evaluated.
Chen <i>et al.</i> [98] - Proposes <i>LogTransfer</i> , to transfer anomalous log knowledge from the source system to the target system.	Proprietary switch logs over a two-year period, and <i>Hadoop</i> application and <i>HDFS</i> logs.	<i>LogTransfer</i> still requires anomalous instances of the target system for optimal performance. It achieves 0.84 <i>F1-score</i> , better results than unsupervised and supervised approaches, such as <i>DeepLog</i> and <i>LogAnomaly</i> .	It applies <i>Glove</i> [196], an unsupervised word representation technique, to convert words in log templates to fixed-dimension vectors.	In the comparison section, unsupervised methods, <i>e.g.</i> , <i>DeepLog</i> is supposed to be trained on normal logs and not on a mix of normal and abnormal logs [5].
Yang <i>et al.</i> 2021 [89] - Introduces <i>PLELog</i> , a semi-supervised anomaly detection through execution logs.	Experimented on <i>BGL</i> and <i>HDFS</i> logs.	With probabilistic label estimation (PLE), it can automatically assign labels to unlabeled datasets. <i>PLELog</i> outperforms compared semi-supervised and unsupervised anomaly detection approaches in terms of F-Measure.	It leverages an attention-based GRU neural network to detect anomalies.	The effectiveness of <i>PLELog</i> falls short compared to some prior anomaly detection approaches, <i>e.g.</i> , <i>LogRobust</i> [104].

TABLE 13: Log anomaly detection research - Topic (H) (continued).

statement description, and automated log analysis of logs, *e.g.*, anomaly detection.

Table 17 summarizes research in **Category L**.

**Finding 5.** *Researchers have contributed to logging research in various categories, and research continues to progress in the existing categories and also grows to the emerging domains. Prior research spans through logging cost and practices, mining and automation of logging code, and mining and automated analysis of log files.*

## 6 RQ4: CHALLENGES AND OPPORTUNITIES FOR FUTURE WORK

In the previous sections, we reviewed and discussed the state-of-the-art logging research by providing an introduction to log messages and log files (2), costs and benefits associated with logging (5.1), mining logging statements (5.2), automated logging approaches and their evaluation metrics (5.3), mining of log files (5.4), and finally, the emerging areas of log application (5.5). In this section, as we revisit each section, we put emphasis on answering RQ4 and specify future directions and opportunities for each category. We point out the missing pieces of the puzzle for each area, followed by our intuitive approaches for tackling those issues, which are inspired by the collective knowledge of the prior work. In the following, we include opportunities for future work based on the research categories.

### 6.1 Category A: Logging Cost

#### 6.1.1 Adaptive and Constraint-Based Logging

An imperative trend that we foresee as future research is the need for adaptive logging [51]. On the one hand, continuously logging in details (*e.g.*, in trace verbosity level) can infer performance overhead, and on the other hand, logging very little might degrade the effectiveness of the logs. Therefore, we anticipate further research that will work on dynamically adjusting the amount of logged data from the least verbose to the most verbose level in order to help with detailed postmortem analysis, if the system is in a detected anomaly state, and on the other side, minimize the performance overhead of logging while the system operates normally and as expected.

#### 6.1.2 Whether to Log?

We mentioned that the prior research has explored various challenges such as '*what to log?*', '*where to log?*', and '*how to log?*'. We see potential for further research on all challenges of logging and with more emphasis on '**whether or not to log?**'. With the emergence of adaptive logging and logging less when not needed and log more details whenever necessary, the idea of whether or not to ultimately print an existing logging statement becomes of importance. We foresee future research that explores different scenarios of whether logging statements are eventually printed or filtered based on the goal of the logging analysis tasks, *i.e.*, performance evaluation or failure diagnosis, and the

Reference - Aim	Experiments	Results	Pro	Con
Tang <i>et al.</i> [137] - Proposes a log-based approach to identify <i>service composition patterns</i> by finding associated services using <i>Apriori algorithm</i> .	A case study on 74 service-oriented applications.	The approach can detect service composition patterns from control flow with a high accuracy.	The approach first starts with collecting and preprocessing of execution logs, and continues with identification of frequent web services, and then extrapolates the control flows.	The approach fails to extract service patterns in cases that control flow has alternative branches.
Oliner and Aiken [113] - Proposes an approach to infer the interactions among the components of large-scale systems by analyzing logs.	Log of eight systems: four supercomputers ( <i>Blue Gene/L</i> , <i>Thunderbird</i> , <i>Spirit</i> , and <i>Liberty</i> ), two data clusters ( <i>Mail Cluster</i> and <i>Junior</i> ), and two autonomous vehicles ( <i>Stanley</i> and <i>SQL Cluster</i> ).	Log data signal compression allows for the scalability of 'lag' correlation, and with minimal loss, this approach identifies system's behavioral model.	Performs a two-stage analysis: 1) PCA compression to summarize the anomaly signals, and 2) lag correlation to identify if the signals relate to each other with a time lag.	The extracted signals show correlation and not a causal relationship, and in addition, manual analysis of a system administrator is required to make sense of the data.
Fu <i>et al.</i> [118] - Proposes <i>LogMaster</i> , a tool to mine correlations of events in log files of large-scale cloud and high-performance computing (HPC) systems.	Experimented on three system logs, namely: <i>Hadoop</i> , <i>HPC cluster</i> and <i>BlueGene/L</i> .	Results show the approach is successful in correlating events related to failures with acceptable <i>precision</i> scores but with lower <i>recall</i> rates.	LogMaster parses the log lines into event sequences where each event creates an informative nine-tuple, and then uses an algorithm, named Apriori-LIS, to mine event rules from logs, and measures the events correlations.	Experiments on cloud and HPC systems shows LogMaster can predict failures with high <i>Precision</i> , however, the <i>Recall</i> scores are low and require improvement.
Shang <i>et al.</i> [90] - Suggests using execution logs from the cloud environment to assist developers of Big Data Analytics (BDA) applications.	A case study on three Hadoop-based apps: <i>WordCount</i> , <i>PageRank</i> , and <i>JACK</i> (industrial).	The approach reduces the verification effort and reaches comparable precision with traditional keyword search methods in verifying cloud deployment procedures.	This approach exposes the differences between pseudo and large-scale cloud deployments and it points the developers' to examine the inconsistencies, and therefore, facilitates the deployment verification effort.	The approach suffers from a high number of false positives in flagging presumptive problematic log sequences, and results in low precision.
Awad and Menascé [136] - Proposes an approach to use system logs and configuration files to automatically extract performance models of the system.	Experiments on <i>Apache Tomcat access logs</i> from a multi-tier server.	The results show the method is effective in extracting the workloads and system model by parsing the system configuration files and log files.	The approach extracts the interaction patterns between servers and devices and the probability associated with each interaction.	The work assumes the log templates are known for the systems under analysis.
Di <i>et al.</i> [125], [197] - Proposes <i>LogAider</i> , an analysis tool that mines potential correlations between various system events for the diagnosis purpose.	Logs of <i>BlueGene/Q Mira</i> supercomputer [198].	The approach shows effective correlation between fatal system events and job events, with both high precision and recall values (99.9-100%).	LogAider can reveal three types of potential correlations between log events: <i>acrossfield</i> , <i>spatial</i> , and <i>temporal</i> .	It uses a threshold to find correlation candidates, and the evaluation scores, such as <i>Precision</i> and <i>Recall</i> , appear to be threshold dependent and vary significantly with the threshold.
He <i>et al.</i> <i>et al.</i> [103] - Proposes <i>Log3C</i> , a clustering-based approach to detect system problems.	Three datasets of an online large-scale service system <i>X</i> from Microsoft (confidential).	Log3C achieves F1-measures values 0.91, 0.86, and 0.868 for three datasets, and outperforms PCA and Invariant Mining approaches.	It applies cascading clustering to cluster and match the log sequences efficiently, and then correlates the log sequence clusters with KPIs to identify the impactful problems.	The research only considers a single KPI, <i>i.e.</i> , <i>failure rate</i> , to correlate with the log sequences. The research can be enriched with the inclusion of additional KPIs.

TABLE 14: System's runtime behavior research - Topic (I).

operating state of the system, *i.e.*, normal state vs. when a system anomaly is detected.

## 6.2 Categories B, C, D: Logging Practices, progression, and Issues

### 6.2.1 Improved Logging Practices

Although logging practices in the software development process have been reviewed and improved over the past decade [28], [29], there is still room for betterment [80]. Additional tools that can automatically detect log-related issues are required. Moreover, because the majority of current logging practices and decisions are *ad-hoc* and decided by developers on the spot, the introduction of systematic logging practices that can provide suggestions to developers while composing the code can ensure a higher quality of logs. Also, further research that can provide directives and insights for developers with regards to good versus poor

logging practices, and hence help to improve their logging practices and make better use of logging, is of interest. For example, more effective logging can enable the customers of the software systems to solve problems themselves using the logs without relying on developers or avoid unnecessary logging costs, such as exposing users' sensitive information in the logs [37]. Another angle for logging practices improvement includes studies that investigate cost-aware logging, which can help developers to estimate and optimize the cost of logging while benefiting from the logs. Although efforts such as Log20 [33] have aimed to address this issue, there is still a sizable room to improve upon. This avenue of future research can be also expanded to other platforms such as mobile devices as the logging practices can be different depending on the applications and the system requirements [85]. Prior research has shown other areas such as mobile systems, that are not in the research



Reference - Aim	Experiments	Results	Pro	Con
Cinque <i>et al.</i> [115] - Proposes a software fault injection approach to assess the effectiveness of logs in the recording of software faults in the deployed environment.	Three open-source systems: <i>Apache Web Server</i> , <i>TAO Open Data Distribution System</i> , and <i>MySQL Database Management System</i> .	Approximately, only 40% of the injected faults are covered by the existing logging statements in the three studies systems.	Faults are intentionally injected into the experimented software systems to determine the most common failure sequences and identify logging deficiencies and improve them.	The faults are synthetic (might not necessarily match real faults) and it requires access to the source code of the software.
Chuah <i>et al.</i> [130] - Presents an approach to reconstruct event order and establish correlations among log events to discover the root causes of a given failure.	<i>Syslogs of Ranger and Turing supercomputers</i> , and <i>BlueGene/L RAS logs</i> .	The authors received positive feedback from system admins that they have found the tool analysis useful in facilitating their diagnosing efforts.	Introduces a <i>Fault Diagnostics</i> tool <i>FDiag</i> , to discover faults, which comprises three components: a <i>Message Template Extractor</i> (MTE), a <i>Statistical Event Correlator</i> (SEC), and an <i>Episode Constructor</i> .	The approach depends on the availability of event-specific keywords as domain knowledge for correlation, and does not provide causality.
Yuan <i>et al.</i> [6] - Proposes <i>SherLog</i> , a tool that leverages runtime log information and source code analysis to infer the probable execution paths during a failed production run.	Evaluated on eight real-world software failures collected from different application such as <i>rmdir</i> , <i>Squid</i> , and <i>ln</i> .	The experiments show the information inferred by <i>SherLog</i> is useful to assist developers in failure diagnosis.	By accepting the execution log of a failed run and the source code, <i>SherLog</i> aims to identify what must or may have happened along the execution path.	<i>SherLog</i> relies on the amount of information available in log messages to perform its analysis. As such, log messages that lack the necessary debugging information will significantly limit <i>SherLog's</i> effectiveness.
Pecchia <i>et al.</i> [99] - Conducts an experimental study to examine factors from event logs that help with the detection of failures.	Performs experiments on a set of 17,387 instances of injecting faults into three systems: <i>Apache Web Server</i> , <i>TAO Open DDS</i> , and <i>MySQL DBMS</i> .	Features such as system architecture, placement of the logging statements, and support provided by the execution environment can have an impact on the accuracy and effectiveness of the logs at runtime.	This research additionally investigates the logging improvement that can potentially increase the usefulness of the execution logs.	The approach requires access to the source code and is only tested on open-source projects.
Nagaraj <i>et al.</i> [7] - Presents <i>DISTALYZER</i> , a tool which utilizes log data to assist developers in diagnosing performance problems.	Case studies on three systems: <i>TritonSort</i> , <i>HBase</i> , and <i>BitTorrent</i> .	Results show that <i>DISTALYZER</i> is able to uncover undiagnosed performance issues for the experimented systems.	<i>DISTALYZER</i> uses machine learning techniques ( <i>i.e.</i> , <i>Welch's t-test</i> [199] and <i>dependency networks</i> [200]) to compare log files with acceptable and unacceptable performance.	<i>DISTALYZER</i> leverages <i>ad-hoc</i> approaches ( <i>e.g.</i> , thread id) to group log messages, which limits its application for less-structured logs.
Fronza <i>et al.</i> [39] - Proposes an approach to perform log-based prediction by applying <i>Random Indexing (RI)</i> and <i>Support Vector Machines (SVMs)</i> .	Experimented on log files of a large European manufacturing company (anonymous).	According to the findings, weighted SVMs achieve the best performance by slightly shrinking specificity (true negative rate) scores to improve sensitivity or recall, and specificity stays greater than 0.8 in the majority of the experimented applications.	It applies weighted SVM, which utilizes cost-sensitive learning to achieve balanced TPR and TNR values, and makes the method more reliable in classifying both failures and non-failures.	SVM classification performs well in classifying non-failure instances, but poor in identifying failures, <i>i.e.</i> , low true positive rate or recall.
Syer <i>et al.</i> [8] - Proposes an approach that combines performance counters and execution logs to diagnose memory-related issues in load tests.	A case study of <i>WordCount</i> application on <i>Hadoop</i> .	The approach flags less than 0.1% of the execution logs with a high precision of ( $\geq 80\%$ ).	After clustering the events, authors apply scoring techniques to identify clusters that are abnormal and can be associated with a performance issue.	The approach has limited applications to memory performance issues, such as memory leaks, spikes, and bloats.
Zhao <i>et al.</i> [109] - Proposes <i>lprof</i> , a log profiling tool that recreates the execution flow of distributed applications.	Evaluated on four distributed systems: <i>HDFS</i> , <i>Yarn</i> , <i>Cassandra</i> , and <i>HBase</i> .	<i>lprof's</i> reaches 88% accuracy in attributing log messages to requests, and 65% of the diagnostics are helpful for the operators.	<i>lprof</i> performs control-flow (CF) and data-flow (DF) analyses, and infers if log messages are causally related and what variables are unmodified between multiple log printing statements, and then groups the logs and use them for diagnosing performance issues.	The <i>lprof's</i> static analysis is limited to a single software component and needs to be readjusted for different languages (bytecode), which is cumbersome in practice.
Xu <i>et al.</i> [112], [144] - Utilizes system logs to provision rolling updates in a cloud environment for process oriented dependability (POD) analysis.	Experiments with rolling upgrade on AWS with injecting 8 different types of faults into the cloud-based clusters. Faults include <i>machine image (MI) change during upgrade</i> , <i>key pair management fault</i> , and <i>security group configuration fault</i> .	The evaluation results show acceptable performance (90+%) in precision, recall, and accuracy scores in diagnosing the injected sporadic faults.	It creates a process model of the desired provisioning activities through log data with added annotation and checkpoints. The deployment logs are checked and assertions are raised in case there has been a deployment violation.	The approach heavily relies on the specific information in the logs and the absence of this information severely impacts the performance of error detection. Following research [101] aims to combine logs with system metrics for a more robust analysis.

TABLE 15: Performance, fault, and failure diagnosis research - Topic (J).

Reference - Aim	Experiments	Results	Pro	Con
Russo <i>et al.</i> [75] - Proposes an approach to mine and learn error predictors from system logs, and then applies it to a real telemetry system for failure prediction.	Experimented on log sequences of 25 different applications of a software system for telemetry and performance of cars.	The evaluation achieves 78% <i>recall</i> , and 95% <i>precision</i> .	Uses three popular support vector machines (SVMs): multi-layer perceptron, radial basis function, and linear kernels - to learn and predict <i>defective</i> ( <i>i.e.</i> , faulty) log sequences.	The study is performed on the logs of a single system. Thus, the result of the applicability of the proposed approach to other systems and other software domains remains unknown.
Yu <i>et al.</i> [111] - Introduces <i>CloudSeer</i> , a lightweight and non-intrusive approach that works on interleaved logs for cloud workflow monitoring.	CloudSeer is prototyped and evaluated on an open-source platform, <i>i.e.</i> , multi-user <i>OpenStack</i> logs.	The approach is accurate enough to check and infer workflows for most interleaved log sequences. Cloudseer reaches 92+% accuracy in checking interleaved logs for six experimented groups with a satisfactory checking efficiency ( <i>i.e.</i> , computation time).	CloudSeer constructs <i>automatons</i> for the workflow of management tasks based on their normal execution scenarios, and later checks log messages against these <i>automatons</i> to detect workflow discrepancies and divergences in an online approach.	The performance problems are only detected for log entries with 'ERROR' log verbosity level, and model creation requires multiple executions of a single task. For messages which do not accompany an error, finding a timeout is not trivial and requires further discussion.
Gurumdimma <i>et al.</i> [120] - Introduces <i>CRUDE</i> , which combines console logs with <i>resource usage</i> data to improve the error detection accuracy in distributed systems.	Experimented on <i>Rationalized logs</i> (ratlogs) from the Ranger Supercomputer containing four weeks worth of data: resource usage data (32GB) and rationalized logs (1.2GB).	The approach is able to identify 80% of errors leading to failures, and achieves f-measure over 70%.	The approach has three main steps: it clusters nodes with similar behavior, then uses an anomaly detection algorithm to detect jobs with anomalous resource usage, and finally, links anomalous jobs with erroneous nodes.	The proposed approach does not model temporal relationships to improve fault identification [201].
Zhao <i>et al.</i> [9] - Introduces <i>Stitch</i> , a distributed and end-to-end performance profiler by flow reconstruction.	Evaluated both through a controlled user study and lab experiments on <i>Hive</i> , <i>Spark</i> , and <i>OpenStack</i> .	On average, <i>Stitch</i> achieves 96% and 95% accuracy for object and edge detection, respectively, for workflow reconstruction.	<i>Stitch</i> aims to construct the system model and the hierarchical relationship of objects in a distributed software stack without requiring domain-specific knowledge.	Although <i>Stitch</i> can establish correlations between different software's objects and modules, it cannot accurately infer causal relationships among them.
Zou <i>et al.</i> [129] - Proposes <i>UiLog</i> , which is a fault analysis tool, to collect logs and their statistics from various components and diagnose the detected faults.	Performs experiments on logs of components ( <i>e.g.</i> , disk, I/O, memory) of a cloud environment, <i>Strong-Cloud</i> , collected over a year period.	Twelve categories of faults are detected, and fault detection precision is maxing out at 88% when the length of logs is more than 200 words.	The approach classifies logs by the fault type in real-time and performs fault correlation analysis to help administrators and locate the faults' root causes.	Requires domain knowledge, and the precision of fault analysis is dependent on the size of the logs.
Zhang <i>et al.</i> [10] - Introduces <i>Pensieve</i> , a flow reconstruction tool for performance failure reproduction through system logs and bytecode.	Evaluated on 18 randomly sampled real failures on four systems: <i>HDFS</i> , <i>HBase</i> , <i>ZooKeeper</i> , and <i>Cassandra</i> .	<i>Pensieve</i> is able to reproduce 72% of the sampled failures within ten minutes of analysis time.	<i>Pensieve</i> leverages event chaining, and extrapolates a chain of causally dependent events leading to the failure while using <i>partial trace observation</i> technique, which significantly limits the execution paths to observe.	Some domain-specific knowledge or a developer familiar with the system is needed to actually describe and diagnose the failure, and make sense of the chain of the events.

TABLE 15: Performance, fault, and failure diagnosis research - Topic (J) (continued).

community's spotlight, are even more in dire need of systematic guidance and automated support tool for assisting in logging practices [85].

### 6.2.2 Representation of Log Files

It is a safe assumption that the log analysis methods require, or at the very least, perform better on logs with good quality to conduct meaningful analyses. Therefore, we foresee future research in improving the formatting and defining universal structure for log messages, which will directly help in achieving more symmetric organization of log files, and consequently, more effective log analysis with higher *Precision* and *Recall* values. This goal is also partially realized with proper selection and improvement of logging libraries and utilities, *e.g.*, Log4j, SLF4j, and Logback.

### 6.2.3 Logging Libraries and Utilities

Logging libraries and utilities (LLU) provide additional functionality, structure, and flexibility in logging for developers such as log verbosity levels and thread-safety [50]. Although LLUs facilitate logging, there has been insufficient research on this topic. Further research that aims to improve the performance of logging libraries by performing some of

the logging tasks during the compile time is necessary [207]. Furthermore, the development of application-specific logging libraries will provide higher logging flexibility and better API for developers in a specific domain, similar to *Log++* [208] for cloud logging, to perform workload-related logging. For example, in a cloud deployment and provisioning process, users are further interested in logging the machine image initialization and termination steps in more details to enable better debugging in case of failures. Additionally, LLUs can improve to bring in new configurability, such as supporting different log verbosity levels for separate parts of a logging statement [37]. Another angle that LLUs can improve is to provide checks on the format of the developer's provided logging text and ensure that the provided content passes a minimum set of standards in order to make logs more useful and organized. Additionally, logging libraries can help to reduce the overhead of logging. The way that some of the LLU work is that, during the runtime, all of the logging statements are executed but based on the verbosity level of the logging statements, some of the logs are filtered from being written to the log file. This approach can still introduce a considerable overhead if logging statements make calls to other methods and

Reference - Aim	Experiments	Results	Pro	Con
Lee <i>et al.</i> [15] - Employs a unified logging infrastructure in Twitter to perform analysis on the user statistics by the use of log data.	“Client events” within Twitter logging framework.	Discusses a variety of applications for the proposed approach, such as <i>summary statistics</i> , <i>event counting</i> , <i>funnel analytics</i> , and <i>user modeling</i> .	The research applies techniques from natural language processing (NLP) to process the user’s behavior on the website; the user’s behavior right now is strongly influenced by immediately preceding actions.	Currently, user session sequences only capture event names and do not provide enough details for more sophisticated types of analyses.
Lim <i>et al.</i> [86] - Addresses the problem of automated identification of recurrent and unknown performance issues.	Evaluated on two datasets: Transaction Processing Performance Council BenchmarkTM W (TPC-W) [202], and System X, a real production system (confidential).	The results show the approach achieves higher <i>AUC</i> when compared to approaches such as <i>Fingerprint</i> , <i>Signature</i> , <i>K-means</i> , and <i>Hierarchical</i> approaches in recurrent and unknown issues identification.	The approach works based on the mining and metric extraction of historical log records, and utilizes a <i>Hidden Markov Random Field (HMRF)</i> based approach for the clustering of recurrent issues.	The proposed statistical analysis only works if a large amount of monitoring data over a long period of time is available.
Oprea <i>et al.</i> [114] - Proposes a framework that analyzes log data collected at the enterprise network borders on a regular basis ( <i>e.g.</i> , daily).	Experimented with DNS logs released by <i>Los Alamos National Lab (LANL)</i> , and AC dataset of web proxies logs generated at the border of a large enterprise network (confidential).	The approach can detect malicious web domains with high accuracy and low false-negative rates. The work also detects new malicious domains that are not previously reported/detected by other tools in the enterprise.	Creates a bipartite graph $G = (V, E)$ , such that hosts and domains are vertices on each side of the graph. There will be an edge between a host and a domain if the host connects with the domain.	The approach cannot detect regular connections to malicious domains which happen in the training phase.
Barik <i>et al.</i> [14] - Performs a case study of log utilization in Microsoft for business decisions and analytics.	Performed interviews with 28 engineers at Microsoft, and followed that up with a survey of 1,823 respondents to confirm their findings.	Use of log event data is pervasive within the organization and the usage primarily falls into eight categories, among them <i>engineering the data pipeline</i> , <i>instrumenting for event data</i> , <i>troubleshooting problems</i> , and <i>making business decisions</i> .	This research highlights that event log data surely plays an important role in the company’s decision-making process as the industry makes a transition towards a data-driven decision-making paradigm.	The study is performed on a single software company and the findings may not generalize to other software and institutions.
Chen <i>et al.</i> [106] - Presents an approach, called LogCoCo ( <i>i.e.</i> , <b>Log-based Code Coverage</b> ), to estimate and measure the source code coverage using the readily-available execution logs.	Five commercial proprietary projects from <i>Baidu</i> and one open-source project, <i>i.e.</i> , <i>HBase</i> .	Measures the accuracy and usefulness of LogCoCo, and it achieves high accuracy for different types of code coverage ( <i>Must</i> and <i>May</i> have been executed). Additionally, the tool’s results are useful to evaluate and improve the test suites for code coverage.	Using program analysis techniques, LogCoCo matches the execution logs with their corresponding code paths and estimates three different code coverage criteria: 1) <i>method coverage</i> , 2) <i>statement coverage</i> , and 3) <i>branch coverage</i> .	The approach cannot accurately infer whether a <i>May</i> executed code region is actually covered in a test.

TABLE 16: User, business, security, and code coverage research - Topic (K).

variables. To cope with this situation, developers include log statement guarding (*e.g.*, putting the log statement inside an *if-clause*) to avoid the logging statement being executed based on whether or not the level is enabled. Therefore, this type of log guarding improvement would be beneficial to be implemented inside the LLUs [80].

#### 6.2.4 Application Specific Logging

As logging messages can provide valuable information with regards to the different aspects of the running software, it is also evident that different tasks and applications that rely on logs require different types of information from the log files. Therefore, we anticipate application-specific logging research in the future to grow. That is to say, depending on the application, we need to log different categories of runtime information. For example, for a security log, certain values need to be printed while not compromising sensitive information; however, this might not be an issue in post-mortem analysis of logs [209]. Additionally, developers of other platforms, such as mobile apps, should be aware of the differences between desktop/server and mobile practices as it comes to logging, as for mobile, there is energy overhead concern that should be taken into account [85]. Therefore, different platforms also might end up logging different

information with varied frequencies of outputting logging statements.

#### 6.2.5 Maintenance of the Logging Code

As the software systems continue to grow, maintaining the logging code becomes more challenging. Previous studies have observed that the logging code is not maintained as well as the feature code, as there is no straightforward way to test the correctness of the logging code [210]. Therefore, we emphasize that further research should consider the systematic maintenance and testing of logging code alongside the feature code evolution. Additionally, there are interesting opportunities for developing automated tools that can read the context of the feature code changes and suggest logging code maintenance and updates concerning the feature code updates while the new feature code is being checked in.

### 6.3 Category E: Log Printing Statement Automation

#### 6.3.1 Automatic LPS Generation

In contrast to developer-inserted logs, LPS automation aims to auto-generate or suggest new logging statements or enhance the quality of currently available logs inside the

Reference - Aim	Experiments	Results	Pro	Con
Miransky <i>et al.</i> [57] - Discusses the challenges of event log analysis for big data systems (BDS), as the logs generated by a BDS can be big data themselves.	Categorizes seven challenges of log analysis for big data systems.	Highlights currently available solutions to each challenge and discusses unanswered questions, based on the authors' and industrial experience.	The authors categorize the challenges of big data log processing into seven classes, including <b>scarce storage</b> , <b>unscalable log analysis</b> , <b>inaccurate capture &amp; replay</b> , and <b>inadequate tools for instrumenting BDS source code</b> .	Accurate mapping and case studies and examples of challenges in real-world big-data software can further illustrate the current issues.
Salman <i>et al.</i> [146] - Proposes <i>PhelkStat</i> , a tool for analysis of system event logs of large-scale data centers on Apache Spark's big data platform.	A set of public ( <i>e.g.</i> , <i>Spirit</i> , <i>Thunderbird</i> , and <i>Liberty</i> ) and private ( <i>e.g.</i> , Cray and dartmouth/campus) log data.	Performs evaluation on a set of log analysis tasks such as <i>arrival rate distribution</i> , <i>anomaly content</i> , and <i>run-time analysis</i> .	The authors utilized a set of attributes, <i>i.e.</i> , temporal and spatial metrics such as arrival rate and byte count, to characterize system event logs and then correlate the metrics with the runtime performance of the system.	Log analysis tasks are partially correlated with system events, but are not analyzed meaningfully to draw actionable steps for admins and users of the system.
Mavridis <i>et al.</i> [102] - Evaluates various log file analysis tasks with two cloud computational frameworks, <i>Apache Hadoop</i> and <i>Apache Spark</i> .	Experiments on log files of an <i>Apache HTTP server</i> , and implemented useful log analysis tasks such as checking for denial of the service (DoS) attacks from the available logs.	Compared performance of Hadoop and Spark by evaluating their execution time, scalability, resource utilization, and cost and power consumption	The research showed the potential of utilizing distributed big-data platforms for facilitating log analysis.	The analysis needs to be expanded to designing tools that can leverage the parallelism of distributed big-data platforms to accomplish a faster and scalable analysis of logs.
Chowdhury <i>et al.</i> [84] - Performs an exploratory study to investigate the energy impact of logging in Android applications using GreenMiner [206], an automated energy test-bed for mobile applications.	Studies approximately a thousand versions of 24 Android applications ( <i>e.g.</i> , CALCULATOR, FEEDEX, FIREFOX, and VLC) with logging enabled and disabled, accompanied by a controlled experiment on a synthetic application.	There is little to no energy impact when logging is enabled for most versions of the studied applications. However, about 79% (19/24) of the studied applications have at least one version that exhibits a noticeable impact on energy consumption.	The authors found that <b>the rate of logging</b> , <b>the size of messages</b> , and <b>the number of log buffer flushes</b> are significant factors of energy consumption attributable to logging on mobile devices.	More accurate models that correlate mobile log events with the amount of energy consumption are required.
He <i>et al.</i> [107] - Characterizes natural language attributes of log statements' descriptions.	Experiments on ten Java and seven C++ open-source projects and answers four research questions.	Findings confirm the natural characteristics of logs, such as endemic and specific.	Proposes an automated approach for log description prediction based on source code similarity and edit distance.	The dynamic part of the log statements is left out, and the approach for log description automation is limited to cases that a similar code snippet is found.
Zeng <i>et al.</i> [85] - Replicates the work of Yuan <i>et al.</i> [28] and investigated the logging practices in Android applications.	Performs a case study on 1,444 open-source Android applications in the F-Droid repository.	Although mobile app logging is less pervasive than server and desktop applications, logging is leveraged in almost all studied mobile apps, and there are noticeable differences between the logging practices applied in mobile applications versus the ones in server and desktop applications, as observed by prior studies [28], [77].	The majority of the logging statements in mobile apps are in <i>debug</i> and <i>error</i> verbosity levels, while <i>info</i> level logging statements are the prevailing level in server and desktop applications.	The research can be expanded by providing developers with guidelines for mobile apps.
Gholamian and Ward [93] - Performs an experimental study on natural and local characteristics of log files.	Experiments on eight system logs ( <i>e.g.</i> , <i>HDFS</i> and <i>Spark</i> ), and two natural language language data ( <i>e.g.</i> , <i>Gutenberg</i> and <i>Wiki</i> ).	Six findings confirm that log messages are natural and local, even more or so than common English text.	Applies the findings and proposes an NLP-based anomaly detection approach from log files, which utilizes n-gram models.	More advanced NLP models ( <i>e.g.</i> , deep learning and BERT) need to be investigated to improve the anomaly detection task.

TABLE 17: Emerging log research - Topic (L).

source code based on various source code and application criteria. Although this topic has been of interest recently [30], [33], [36], [66], [67], [88], [108], considering the continuous advancement and birth of new AI and learning methods, we anticipate future research in the development of machine learning methods to implement and automate logging, with statistical modeling, supervised, unsupervised, and deep learning approaches will continue to foster. These methods should consider automating different aspects of the logging statements, such as the *location*, *content*, and *verbosity level*. The automated methods can also consider different criteria for automation, such as diagnosability versus cost-awareness [37]. The ultimate goal is to achieve an automated approach that can introduce high-quality log suggestions or enhancements for various applications. Subsequently, assuming the development of

different approaches, a comparative study of different approaches and the areas that each one performs better becomes necessary, similar to the comparison of different log parsing techniques in [54].

### 6.3.2 Constraint-based Logging

The majority of the log automation tools have aimed to mimic developers' logging habits [30], [36], [108]. In other words, the log learning approaches work to learn developers' logging habits to decide if a new unlogged code snippet requires a logging statement. However, prior work [80] has also shown that developers make mistakes, and in some places, they even forget to log in the first place. Thus, one remaining important challenge is to develop constraint-based automated logging approaches to guarantee a particular logging goal, *e.g.*, at minimum, one iteration out of

100 iterations of method  $MtdM()$  is logged, or a particular execution path is fully disambiguated with logging, *i.e.*, we can accurately determine which code segments ‘*must*’ have been executed. Another example can be ensuring the beginning and the end of all methods of interest are logged. By doing so, we can guarantee that at least a minimum quality of logs is granted.

### 6.3.3 Golden Quality LPSs for Benchmarking

To the best of our knowledge, there is no prior work that quantitatively measures the quality of logging statements in each software project. Many of the prior work consider the developers’ inserted logging statements as ground truth to evaluate their automated logging approach [30], [36], [108]. However, prior research has shown that there is no general guideline for logging and developers mostly rely on their intuitions and insert logging statements in an *ad-hoc* manner [97]. As such, defining a set of quantitative metrics that can be applied to evaluate the quality of logs on various software projects and give them scores can be highly beneficial. This allows to find projects with high-quality logs, learn from them, and use them as a *golden benchmark* for comparison with auto-generated logs.

## 6.4 Category F: Log Maintenance and Management

**Log collections and compressors.** Log collections, similar to LogHub [124], are useful for evaluating various log analyses. Additionally, datasets that are labeled and differentiate normal against abnormal log records are well sought after, as they enable the application of supervised and deep learning approaches for log analysis [104], [211], [212]. As such, we see value in further research to collect log data from various software and application domains, and develop automatic and accurate probabilistic methods [89] to label the data to facilitate log analysis and logging practices research. For log compression, because logs generally benefit from higher repetition than natural text, future research can benefit from designing and evaluating log-tuned compressors, which not only can result in more effective compression but also more efficient and streamlined decompression, for later auditing and analysis.

## 6.5 Categories H, I, J, K: Automated Log Analysis Applications

### 6.5.1 Log Analysis and Tools

Prior research has proposed plenty of log analysis methods and tools for different applications, such as **anomaly and problem detection** [2], [4], **performance and failure diagnosis** [9], [10], [109], [111], **system’s runtime behavior** [90], [103], [177], **system profile building** [114], **code quality assessment** [78], and **code coverage** [106]. Log analysis, starting with log parsing, plays an essential role in extracting useful information from the log files. As logs can be viewed in different ways, such as events, time series, and feature vectors, this enables different types of analyses. Complementary to the available research, because logs are non-intrusive and readily available, we anticipate new methods of log analysis or improvement of the current methods will be sought after for different applications. The

quality of log analysis can directly impact the amount of actionable information that we can extract from the log files. Therefore, we expect new logging analysis approaches will emerge that utilize and combine a variety of algorithms to achieve a more accurate analysis. The approaches might also assume a specific format of logs, *e.g.*, log messages following a specific template within the log files, to achieve a more personalized analysis. For example, the research can benefit from considering multiple factors, such as the content of each log message, the frequency, and the sequencing of log messages in log analysis tasks, *e.g.*, anomaly detection, in order to achieve a deeper understanding of what happens in the logs. Lastly, we foresee that future research will benefit from utilizing AI approaches in understanding and leveraging the hidden semantics of the log messages, rather than solely focusing on learning log patterns and templates. This will enable a more sophisticated log analysis.

### 6.5.2 Scalable and Online Log Processing

In order to keep pace with the massive amount of growing logs in size (at the rate of approximately multiple terabytes per day [212]) and various formats, which is the by-product of the software growth as well as the number of software users’ growth, we anticipate further research will be conducted to develop and update the current logging processing tools and platforms. Thus, future research should consider leveraging distributed and parallel processing platforms (*e.g.*, Apache Spark) in conjunction with efficient machine learning approaches to implement scalable log analysis tools for all stages of the process, *i.e.*, real-time collection, processing, and storage of voluminous logs [16]. In addition, as many of the enterprise software platforms require 24/7 up-time and availability, the need for online tools that can perform the log analysis simultaneously as the system generates logs becomes more apparent. We require the tools to be efficient enough to perform analysis at the same speed or faster than the log generation rate.

## 6.6 Category L - Emerging Logging Research

### 6.6.1 Natural Language Processing of Logs

Prior work [214], [215] in software engineering has utilized natural language processing (NLP) for software tasks such as source code next token suggestion. Recently, there has been a thread of research on analyzing logging statements as natural language sequences. He *et al.* [107] characterized the NLP characteristics of LPS descriptions in Java and C# projects, and Gholamian and Ward [93] showed software execution logs are natural and local, and these features can be leveraged for automated log analysis, such as anomaly detection. We hypothesize that further research is required to confirm the NLP characteristics of software logs, and eventually, leveraging NLP characteristics of logs will further benefit automated log generating and analysis of log files. Moreover, the recent advancements in NLP models, *e.g.*, BERT models [219], calls for further investigation and application of them in improving the performance of log mining tasks. The intuition is that these models can embed and learn a higher degree of log semantics, and thus, can better enable actionable diagnosis from logs.

No.	Avenue	Rationale	Selected research
1.	<b>Adaptive logging</b>	Dynamic adjustment of the logging level from the least to the most verbose level helps with detailed postmortem analysis.	[51]
2.	<b>Whether to log?</b>	Different scenarios of whether LPSs are printed or filtered based on the goal of the logging analysis tasks should be studied.	[117]
3.	<b>Logging practices</b>	Future research can improve on logging practices in the software development process and reduce the <i>ad hoc</i> and forgetful developers' logging habits.	[28], [29], [80]
4.	<b>Representation of the log files</b>	Further research can improve the formatting and standardization of log messages, which directly results in more organized log files and more accurate automated analysis.	[32], [213]
5.	<b>Logging libraries and utilities</b>	Logging libraries and utilities (LLU) can provide additional functionality, structure, and flexibility in logging for developers.	[50], [207], [208]
6.	<b>Application-specific logging</b>	Research can investigate and ensure that how different tasks and applications that rely on logs can record application-specific information ( <i>i.e.</i> , based on the application needs) into the log files.	[85], [209]
7.	<b>Maintenance of logging code</b>	As maintenance of the logging code becomes more challenging, future research requires to develop automated approaches to ensure up-to-date and issue-free logging code.	[29], [158], [210]
8.	<b>Automated and constraint-based log generation</b>	Research requires to improve the quality of auto-generated LPSs and, also, enhance the quality of the developer-inserted <i>ad-hoc</i> logs by adding additional variables, <i>etc.</i>	[30], [33], [36], [66], [67], [88], [92], [97], [105], [108]
9.	<b>Golden quality log statements</b>	High quality logs are required to learn from, and use them as a <i>golden benchmark</i> for comparison with auto-generated logs.	[30], [36], [97], [108]
10.	<b>Log collections</b>	There is a need for labeled log data collections and development of automated log labeling approaches to facilitate automated log analysis.	[124], [174], [176]
11.	<b>Log compression</b>	Compressors which are designed for logs are needed to improve the compression/decompression efficiency and enable efficient long-term storage and backup of logs.	[56], [83], [177]
12.	<b>Log analysis for various objectives</b>	Research will actively continue to propose and improve approaches for more accurate log analysis for different log mining tasks and postmortem debugging.	[2], [4], [9], [10], [89], [109], [111]
13.	<b>Scalable and online log processing</b>	Scalable and real-time log processing is required to keep pace with the massive amount of growing logs in size, <i>e.g.</i> , multiple terabytes per day.	[212]
14.	<b>Natural language processing of logs</b>	Leveraging NLP characteristics of logs will benefit automated log generating ( <i>e.g.</i> , log description generation) and NLP processing of log files.	[36], [107], [214], [215]
15.	<b>Log summarization &amp; visualization</b>	Development of approaches that aim to elicit and condense big-picture insights from logs with visualizing and summarization are in demand, and this will enable practitioner to only focus on significantly smaller but most important portion of logs.	[216], [217], [218]

TABLE 18: Summary of avenues for future work in logging research.

### 6.6.2 Log Summarization and Visualization

Prior works [95], [216], [217] have proposed approaches to summarize and visualize console and security logs. Log summarization and visualization is a natural response to the ever-growing scale of logs to gain high-level insight into the logs. In large-scale distributed software systems, as the scale of logs continue to grow, and various subsystems continue to generate logs in heterogeneous formats and rates, we foresee the development of approaches and solutions, both in academia and industry, that aim to make high-level sense of logs and to gain big-picture insight with visualizing logs. In addition, log summarization will help developers and practitioners to focus their troubleshooting efforts on a smaller set of relevant logs. Knowledge graph representation is a potential candidate for this aim [218]. Lastly, we provide a digest of the avenues for future of logging research in Table 18.

**Finding 6.** *Outstanding problems exist for each category of logging research. Future research can consider and tackle these challenges to improve the quality of log statements and log files, and thus enable more effective log analysis tasks.*

## 7 CONCLUSIONS

Logging statements and log files are the inevitable pieces of the puzzle in analyzing and ensuing various aspects of correct functionality of software systems, such as debugging, maintaining, and diagnosability. The valuable information gained from logs has motivated the research and development of a plethora of logging practices, logging applications, and log automation and analysis tools.

In this survey, we initially started with the basics of log statements and log files and the involving challenges in extracting useful information from them in Sections 1 and 2. As we conduct the survey, we aim to answer four crucial research questions related to software logging: **(RQ1)** categories of logging research, **(RQ2)** publication trends based on topics, years, and venues, **(RQ3)** available research in each category, and finally **(RQ4)** challenges and opportunities for future logging research. We next reviewed the costs and benefits associated with logging in Section 5.1 and followed that up with research that mines logging statements to derive logging practices in Section 5.2. In Section 5.3, we reviewed the proposed methods for automated logging, and we mentioned evaluation methods and metrics for auto-generated logs and learning-to-log platforms in Section 5.3.4. In section 5.4, we reviewed log file mining and log analysis research which aims to expedite and scale up the log processing, and apply logs for different system maintenance tasks such as anomaly and failure detection/diagnosis, performance issues, and code quality assessment. We also reviewed the emerging domains and applications for logging, such as in NLP, mobile, and big data in Section 5.5. Finally, we discussed the opportunities for future research in different aspects of logging statements and log files, their practices, and their analyses in Section 6.

Although current research advances have made logs more useful and effective, there are still multiple remaining challenges and avenues for future work and improvement. Categories of challenges remain in various aspects of **automated log analysis**, **LPS auto-generation**, **scalable logging analysis** and **infrastructure**, **cost-aware logging**, **log maintenance and management**, and **improved logging practices**.

We foresee future research in multiple directions for logging as follows:

- As the size of computer systems increases, we anticipate the voluminousness and heterogeneity of logs, which turns it into a big-data problem, will demand further quantitative cost analysis for collecting, processing, and storing of logs, as logging can infer computation, storage, and network overhead. Additionally, due to the voluminousness and heterogeneity of generated logs, and in some cases, the need for real-time processing of logs, we anticipate the development of efficient, scalable, and real-time log analysis tools [57].
- We anticipate continued research on current logging practices and log-statement-related issues, as this will enable improvements of future practices and help to create guidelines for developers when making logging decisions. We also predict the evolvement of learning and AI-based log recommender tools and IDE plugins, which utilize the readily available code repositories of open-source projects to provide just-in-time logging practice suggestions to developers [36], [81]. Additionally, we expect further work on logging libraries to collaborate with emerging logging practices and bring in the development of application-specific logging practices [209].
- We foresee automated log file analysis techniques continue to evolve and become more effective and sophisticated (with machine learning and AI-based techniques) in their information extraction from log files and log statements. We also see an emerging trend of new applications that utilize log analysis recently, such as log analysis for code coverage [106]. Moreover, we predict further research will be performed in enabling the analysis of logs for other platforms, such as mobile systems and big-data applications. Log collections will also continue to grow to help with log analysis.
- With regards to log statement prediction, we anticipate that future research on supervised, unsupervised, and deep learning techniques will continue to benefit logs and their analyses.

In this study, we aim to systematically summarize, discuss, and critique the state-of-the-art knowledge in the logging field for experienced researchers, and simultaneously, help new researchers to get a quick and critical grasp of the available research in this area. Additionally, we envision the uncovered research opportunities in this survey serve as a beacon for advancing the logging research.

## 8 LIST OF PAPERS

Table 19 provides the list of papers per each category of logging research.

Topic	Paper title	Year	Venue	Subtopic(s)
<b>(A) Costs and benefits of logging (5)</b>	Be conservative: Enhancing failure diagnosis with proactive logging [66].	2012	OSDI (J)	(E)
	Linux auditing: Overhead and adaptation [143].	2015	ICC (C)	
	Log2: A cost-aware logging mechanism for performance diagnosis [117].	2015	ATC (C)	(E)
	A qualitative study of the benefits and costs of logging from developers' perspectives [37].	2020	TSE (J)	
	Log4Perf: Suggesting and updating logging locations for web-based systems' performance monitoring [76].	2020	EMSE (J)	(E)
<b>(B) Logging practices (7)</b>	Characterizing logging practices in open-source software [28].	2012	ICSE (C)	(C)
	Where do developers log? An empirical study on logging practices in industry [35].	2014	ICSE (C)	(A), (E)
	Industry practices and event logging: Assessment of a critical software development process [38].	2015	ICSE (C)	
	Studying the relationship between logging characteristics and the code quality of platform software [78].	2015	EMSE (J)	(D)
	Characterizing logging practices in Java-based open source software projects - A replication study in Apache Software Foundation [77].	2017	EMSE (J)	(C)
	An exploratory study of logging configuration practice in Java [152].	2019	ICSME (C)	(C)
Studying the use of Java logging utilities in the wild [50].	2020	ICSE (C)	(C), (D)	
<b>(C) Logging progression (5)</b>	An exploratory study of the evolution of communicated information about the execution of large software systems [68].	2014	JSS (J)	(D)
	Logging library migrations: A case study for the Apache software foundation projects [91].	2016	MSR (C)	(B)
	Examining the stability of logging statements [69].	2018	EMSE (J)	(B), (D)
	Guiding log revisions by learning from software evolution history [79].	2019	EMSE (J)	(D)
	Can you capture information as you intend to? A case study on logging practice in industry [157].	2020	ICSME (C)	(B)
<b>(D) Log-related issues (5)</b>	Simple testing can prevent most critical failures: An analysis of production failures in distributed data-intensive systems [110].	2014	OSDI (C)	(B)
	Understanding log lines using development knowledge [148].	2014	ICSME (C)	(B)
	Characterizing and detecting anti-patterns in the logging code [29].	2017	ICSE (C)	
	Studying and detecting log-related issues [80].	2018	EMSE (J)	(E)
	Studying duplicate logging statements and their relationships with code clones [94].	2021	TSE (J)	(C)
<b>(E) Log printing statement automation (15)</b>	AutoLog: Facing log redundancy and insufficiency [145].	2011	APSys (C)	(A)
	Improving software diagnosability via log enhancement [67].	2012	TOCS (J)	(J)
	Learning to log: Helping developers make informed logging decisions [30].	2015	ICSE (C)	(B)
	LogOptPlus: Learning to optimize logging in catch and if programming constructs [147].	2016	COMPSAC (C)	
	Log20: Fully automated optimal placement of log printing statements under specified overhead threshold [33].	2017	SOSP (C)	(A)
	Towards just-in-time suggestions for log changes [81].	2017	EMSE (J)	(C), (D)
	Which log level should developers choose for a new logging statement? [82].	2017	EMSE (J)	(B)
	SMARTLOG: Place error log statement by deep understanding of log intention [108].	2018	SANER (C)	(A)
	An approach to recommendation of verbosity log levels based on logging intention [141].	2019	ICSME (C)	
	Which variables should I log? [97].	2019	TSE (J)	
	Automatic recommendation to appropriate log levels [128].	2020	SP&E (J)	
	Logging statements' prediction based on source code clones [36].	2020	SAC (C)	(B)
Where shall we log? Studying and suggesting logging locations in code blocks [105].	2020	ASE (C)	(B)	
An exploratory study of log placement recommendation in an enterprise system [92].	2021	MSR (C)	(B)	
DeepLV: Suggesting log levels using ordinal based neural networks [88].	2021	ICSE (C)	(B)	
<b>(F) Log maintenance and management (9)</b>	An integrated data-driven framework for computing system management [126].	2010	TSMCA (J)	(I)
	Cloud application logging for forensics [122].	2011	SAC (C)	
	FLAP: An end-to-end event log analysis platform for system management [134].	2017	KDD (C)	(I), (J)
	Logzip: Extracting hidden structures via iterative clustering for log compression [56].	2019	ASE (C)	(G)
	A study of the performance of general compressors on log files [83].	2020	EMSE (J)	
	Effective removal of operational log messages: an application to model inference* [123].	2020	arXiv (A)	(I)
	Loghub: A large collection of system log datasets towards automated log analytics* [124].	2020	arXiv (A)	(H)
	A survey of software log instrumentation [65].	2021	CSUR (J)	(B), (C)
	LogAssist: Assisting log analysis through log summarization [95].	2021	TSE (J)	
<b>(G) Log parsing (8)</b>	What happened in my network: Mining network events from router syslogs [135].	2010	IMC (C)	(J)
	Baler: Deterministic, lossless log message clustering tool [131].	2011	CSRD (J)	
	LogSig: Generating system events from raw textual logs [133].	2011	CIKM (C)	
	LogCluster - A data clustering and pattern mining algorithm for event logs [13].	2015	CNSM (C)	
	Spell: Streaming parsing of system event logs [87].	2016	ICDM (C)	
	Drain: An online log parsing approach with fixed depth tree [139].	2017	ICWS (C)	
	A search-based approach for accurate identification of log message formats [140].	2018	ICPC (C)	
	Logram: Efficient log parsing using n-gram dictionaries [96].	2020	TSE (J)	(L)

\*Snowballing

TABLE 19: A full list of reviewed publications. 'Subtopic' column shows what other topics are discussed in the research, if applicable.



Topic	Paper title	Year	Venue	Subtopic(s)
<b>(H) Anomaly detection (15)</b>	Detecting large-scale system problems by mining console logs* [2].	2009	SOSP (C)	(J)
	Execution anomaly detection in distributed systems through unstructured log analysis * [4].	2009	ICDM (C)	(G)
	Mining invariants from console logs for system problem detection* [116].	2010	ATC (C)	(G)
	Linking resource usage anomalies with system failures from cluster log data [121].	2013	SRDS (C)	(J)
	DeepLog: Anomaly detection and diagnosis from system logs through deep learning [5].	2017	CCS (C)	(G), (I), (J)
	Experience report: Log mining using natural language processing and application to anomaly detection [17].	2017	ISSRE (C)	(J)
	Execution anomaly detection in large-scale systems through console log analysis* [100].	2018	JSS (J)	(J)
	Metric selection and anomaly detection for cloud operations using log and metric correlation analysis* [101].	2018	JSS (J)	(J)
	LogAnomaly: Unsupervised detection of sequential and quantitative anomalies in unstructured logs [132].	2019	IJCAI (C)	(G)
	Robust log-based anomaly detection on unstable log data [104].	2019	ESEC/FSE (C)	(C)
	Anomaly detection via mining numerical workflow relations from logs [119].	2020	SRDS (C)	
	HitAnomaly: Hierarchical transformers for anomaly detection in system log [127].	2020	TNSM (J)	
	LogSayer: Log pattern-driven cloud component anomaly diagnosis with machine learning [138].	2020	IWQoS (C)	(J)
	LogTransfer: Cross-system log anomaly detection for software systems with transfer learning [98].	2020	ISSRE (C)	
	Semi-supervised log-based anomaly detection via probabilistic label estimation [89].	2021	ICSE (C)	
<b>(I) Runtime behavior (7)</b>	An approach for mining web service composition patterns from execution logs [137].	2010	WSE (C)	
	Online detection of multi-component interactions in production systems [113].	2011	DSN (C)	(H)
	Logmaster: Mining event correlations in logs of large-scale cluster systems [118].	2012	SRDS (C)	(J)
	Assisting developers of big data analytics applications when deploying on Hadoop clouds [90].	2013	ICSE (C)	(J)
	Performance model derivation of operational systems through log analysis [136].	2016	MASCOTS (C)	(J)
	Exploring properties and correlations of fatal events in a large-scale hpc system [125].	2018	TPDS (J)	(J)
	Identifying impactful service system problems via log analysis [103].	2018	ESEC/FSE (C)	(J)
	<b>(J) Performance, fault, and failure diagnosis (15)</b>	Assessing and improving the effectiveness of logs for the analysis of software faults [115].	2010	DSN (C)
Diagnosing the root-causes of failures from cluster log files [130].		2010	HiPC (C)	
SherLog: Error diagnosis by connecting clues from run-time logs [6].		2010	ASPLOS (C)	(I)
Detection of software failures through event logs: An experimental study [99].		2012	ISSRE (C)	(B)
Structured comparative analysis of systems logs to diagnose performance problems* [7].		2012	NSDI (C)	
Failure prediction based on log files using random indexing and support vector machines [39].		2013	JSS (J)	(I)
Leveraging performance counters and execution logs to diagnose memory-related performance issues [8].		2013	ICSE (C)	
lprof: A non-intrusive request flow profiler for distributed systems* [109].		2014	OSDI (C)	(G), (H)
POD-Diagnosis: Error diagnosis of sporadic operations on cloud applications* [112].		2014	DSN (C)	
Mining system logs to learn error predictors: A case study of a telemetry system [75].		2015	EMSE (J)	
Cloudseer: Workflow monitoring of cloud infrastructures via interleaved logs* [111].		2016	ASPLOS (C)	(I)
CRUDE: Combining resource usage data and error logs for accurate error detection in large-scale distributed systems [120].		2016	SRDS (C)	(H)
Non-Intrusive performance profiling for entire software stacks based on the flow reconstruction principle [9].		2016	OSDI (C)	(I)
Uilog: Improving log-based fault diagnosis by log analysis [129].		2016	JCST (J)	
Pensieve: Non-intrusive failure reproduction for distributed systems using the event chaining approach* [10].		2017	SOSP (C)	
<b>(K) User, business, security, and code coverage (5)</b>	The unified logging infrastructure for data analytics at Twitter [15].	2012	VLDB (C)	
	Identifying recurrent and unknown performance issues [86].	2014	ICDM (C)	(J)
	Detection of early-stage enterprise infection by mining large-scale log data [114].	2015	DSN (C)	(H)
	The bones of the system: A case study of logging and telemetry at Microsoft [14].	2016	ICSE (C)	(B), (I)
	An automated approach to estimating code coverage measures via execution logs [106].	2018	ASE (C)	
<b>(L) Emerging applications (7)</b>	Operational-log analysis for big data systems: Challenges and solutions [57].	2016	IEEE Softw (J)	(A), (B), (I)
	Designing PhelkStat: Big data analytics for system event logs [146].	2017	HICSS (C)	(H)
	Performance evaluation of cloud-based log file analysis with Apache Hadoop and Apache Spark [102].	2017	JSS (J)	(A)
	An exploratory study on assessing the energy impact of logging on android applications [84].	2018	EMSE (J)	(A)
	Characterizing the natural language descriptions in software logging statements [107].	2018	ASE (C)	(E)
	Studying the characteristics of logging practices in mobile apps: a case study on F-Droid [85].	2019	EMSE (J)	(A), (B)
	On the naturalness and localness of software logs [93].	2021	MSR (C)	(H)
<b>Total (103)</b>				

\*Snowballing

TABLE 19: A full list of reviewed publications (continued). ‘Subtopic’ column shows what other topics are discussed in the research, if applicable.

## REFERENCES

- [1] M. Cinque, D. Cotroneo, and A. Pecchia, "Event logs for the analysis of software failures: A rule-based approach," *IEEE Transactions on Software Engineering*, vol. 39, no. 6, pp. 806–821, 2012.
- [2] W. Xu, L. Huang, A. Fox, D. Patterson, and M. I. Jordan, "Detecting large-scale system problems by mining console logs," in *Proceedings of the ACM SIGOPS 22nd symposium on Operating systems principles*. ACM, 2009, pp. 117–132.
- [3] Z. M. Jiang, A. E. Hassan, G. Hamann, and P. Flora, "Automatic identification of load testing problems," in *2008 IEEE International Conference on Software Maintenance*. IEEE, 2008, pp. 307–316.
- [4] Q. Fu, J.-G. Lou, Y. Wang, and J. Li, "Execution anomaly detection in distributed systems through unstructured log analysis," in *Data Mining, 2009. ICDM'09. Ninth IEEE International Conference on*. IEEE, 2009, pp. 149–158.
- [5] M. Du, F. Li, G. Zheng, and V. Srikumar, "Deeplog: Anomaly detection and diagnosis from system logs through deep learning," in *Proceedings of the 2017 ACM SIGSAC Conference on Computer and Communications Security*, 2017, pp. 1285–1298.
- [6] D. Yuan, H. Mai, W. Xiong, L. Tan, Y. Zhou, and S. Pasupathy, "Sherlog: error diagnosis by connecting clues from run-time logs," in *ACM SIGARCH computer architecture news*, vol. 38, no. 1. ACM, 2010, pp. 143–154.
- [7] K. Nagaraj, C. Killian, and J. Neville, "Structured comparative analysis of systems logs to diagnose performance problems," in *Proceedings of the 9th USENIX conference on Networked Systems Design and Implementation*. USENIX Association, 2012, pp. 26–26.
- [8] M. D. Syer, Z. M. Jiang, M. Nagappan, A. E. Hassan, M. Nasser, and P. Flora, "Leveraging performance counters and execution logs to diagnose memory-related performance issues," in *2013 IEEE international conference on software maintenance*. IEEE, 2013, pp. 110–119.
- [9] X. Zhao, K. Rodrigues, Y. Luo, D. Yuan, and M. Stumm, "Non-intrusive performance profiling for entire software stacks based on the flow reconstruction principle," in *12th {USENIX} Symposium on Operating Systems Design and Implementation ({OSDI} 16)*, 2016, pp. 603–618.
- [10] Y. Zhang, S. Makarov, X. Ren, D. Lion, and D. Yuan, "Pensieve: Non-intrusive failure reproduction for distributed systems using the event chaining approach," in *Proceedings of the 26th Symposium on Operating Systems Principles*, 2017, pp. 19–33.
- [11] M. Aharon, G. Barash, I. Cohen, and E. Mordechai, "One graph is worth a thousand logs: Uncovering hidden structures in massive system event logs," in *Joint European Conference on Machine Learning and Knowledge Discovery in Databases*. Springer, 2009, pp. 227–243.
- [12] A. A. Makanju, A. N. Zincir-Heywood, and E. E. Milios, "Clustering event logs using iterative partitioning," in *Proceedings of the 15th ACM SIGKDD International Conference on Knowledge Discovery and Data Mining*, ser. KDD '09. New York, NY, USA: ACM, 2009, pp. 1255–1264. [Online]. Available: <http://doi.acm.org/10.1145/1557019.1557154>
- [13] R. Vaarandi and M. Pihelgas, "Logcluster-A data clustering and pattern mining algorithm for event logs," in *Network and Service Management (CNSM), 2015 11th International Conference on*. IEEE, 2015, pp. 1–7.
- [14] T. Barik, R. DeLine, S. Drucker, and D. Fisher, "The bones of the system: A case study of logging and telemetry at microsoft," in *2016 IEEE/ACM 38th International Conference on Software Engineering Companion (ICSE-C)*. IEEE, 2016, pp. 92–101.
- [15] G. Lee, J. Lin, C. Liu, A. Lorek, and D. Ryaboy, "The unified logging infrastructure for data analytics at twitter," *Proceedings of the VLDB Endowment*, vol. 5, no. 12, pp. 1771–1780, 2012.
- [16] J. Candido, M. A. Niche, and A. van Deursen, "Contemporary software monitoring: A systematic literature review," *arXiv preprint arXiv:1912.05878*, 2019.
- [17] C. Bertero, M. Roy, C. Sauvanaud, and G. Trédan, "Experience Report: Log Mining using Natural Language Processing and Application to Anomaly Detection," in *28th International Symposium on Software Reliability Engineering (ISSRE 2017)*, Toulouse, France, Oct. 2017, p. 10p. [Online]. Available: <https://hal.laas.fr/hal-01576291>
- [18] R. Jabbari, N. bin Ali, K. Petersen, and B. Tanveer, "What is devops? a systematic mapping study on definitions and practices," in *Proceedings of the Scientific Workshop Proceedings of XP2016*, 2016, pp. 1–11.
- [19] D. Cukier, "Devops patterns to scale web applications using cloud services," in *Proceedings of the 2013 companion publication for conference on Systems, programming, & applications: software for humanity*, 2013, pp. 143–152.
- [20] A. Dyck, R. Penners, and H. Lichter, "Towards definitions for release engineering and devops," in *2015 IEEE/ACM 3rd International Workshop on Release Engineering*. IEEE, 2015, pp. 3–3.
- [21] "The Epic Guide to Artificial Intelligence for DevOps Automation," <https://www.targetprocess.com/blog/artificial-intelligence-devops-automation/>, 2020.
- [22] "The Data-to-Everything Platform Built for the Cloud," <https://www.splunk.com/>, 2021.
- [23] "What is the ELK Stack?" <https://www.elastic.co/what-is/elk-stack>, 2020.
- [24] "Elasticsearch, the heart of the Elastic Stack," <https://www.elastic.co/elasticsearch/>, 2020.
- [25] "Centralize, transform and stash your data," <https://www.elastic.co/products/logstash>, 2020.
- [26] "Your window into the Elastic Stack," <https://www.elastic.co/kibana>, 2020.
- [27] H. Li, T.-H. P. Chen, W. Shang, and A. E. Hassan, "Studying software logging using topic models," *Empirical Software Engineering*, pp. 1–40, 2018.
- [28] D. Yuan, S. Park, and Y. Zhou, "Characterizing logging practices in open-source software," in *Proceedings of the 34th International Conference on Software Engineering*. IEEE Press, 2012, pp. 102–112.
- [29] B. Chen and Z. M. J. Jiang, "Characterizing and detecting anti-patterns in the logging code," in *Proceedings of the 39th International Conference on Software Engineering*. IEEE Press, 2017, pp. 71–81.
- [30] J. Zhu, P. He, Q. Fu, H. Zhang, M. R. Lyu, and D. Zhang, "Learning to log: Helping developers make informed logging decisions," in *Proceedings of the 37th International Conference on Software Engineering-Volume 1*. IEEE Press, 2015, pp. 415–425.
- [31] "The Apache Software Foundation. logging services project," <http://logging.apache.org/>, 2019.
- [32] F. Salfner, S. Tschirpke, and M. Malek, "Comprehensive logfiles for autonomic systems," in *18th International Parallel and Distributed Processing Symposium, 2004. Proceedings*. IEEE, 2004, p. 211.
- [33] X. Zhao, K. Rodrigues, Y. Luo, M. Stumm, D. Yuan, and Y. Zhou, "Log20: Fully automated optimal placement of log printing statements under specified overhead threshold," in *Proceedings of the 26th Symposium on Operating Systems Principles*, ser. SOSP '17. New York, NY, USA: ACM, 2017, pp. 565–581. [Online]. Available: <http://doi.acm.org/10.1145/3132747.3132778>
- [34] V. R. Basili, F. Shull, and F. Lanubile, "Building knowledge through families of experiments," *IEEE Transactions on Software Engineering*, vol. 25, no. 4, pp. 456–473, 1999.
- [35] Q. Fu, J. Zhu, W. Hu, J.-G. Lou, R. Ding, Q. Lin, D. Zhang, and T. Xie, "Where do developers log? an empirical study on logging practices in industry," in *Companion Proceedings of the 36th International Conference on Software Engineering*. ACM, 2014, pp. 24–33.
- [36] S. Gholamian and P. A. Ward, "Logging statements' prediction based on source code clones," in *Proceedings of the 35th Annual ACM Symposium on Applied Computing*, 2020, pp. 82–91.
- [37] H. Li, W. Shang, B. Adams, M. Sayagh, and A. E. Hassan, "A qualitative study of the benefits and costs of logging from developers' perspectives," *IEEE Transactions on Software Engineering*, 2020.
- [38] A. Pecchia, M. Cinque, G. Carrozza, and D. Cotroneo, "Industry practices and event logging: Assessment of a critical software development process," in *2015 IEEE/ACM 37th IEEE International Conference on Software Engineering*, vol. 2, May 2015, pp. 169–178.
- [39] I. Fronza, A. Sillitti, G. Succi, M. Terho, and J. Vlasenko, "Failure prediction based on log files using random indexing and support vector machines," *Journal of Systems and Software*, vol. 86, no. 1, pp. 2–11, 2013.
- [40] M. Kubacki and J. Sosnowski, "Holistic processing and exploring event logs," in *International Workshop on Software Engineering for Resilient Systems*. Springer, 2017, pp. 184–200.
- [41] S. Keele et al., "Guidelines for performing systematic literature reviews in software engineering," Citeseer, Tech. Rep., 2007.

- [42] B. A. Kitchenham, D. Budgen, and P. Brereton, *Evidence-based software engineering and systematic reviews*. CRC press, 2015, vol. 4.
- [43] B. Napoleão, K. R. Felizardo, É. F. de Souza, and N. L. Vijaykumar, "Practical similarities and differences between systematic literature reviews and systematic mappings: a tertiary study." in *SEKE*, 2017, pp. 85–90.
- [44] C. Wohlin, P. Runeson, M. Höst, M. C. Ohlsson, B. Regnell, and A. Wesslén, *Experimentation in software engineering*. Springer Science & Business Media, 2012.
- [45] A. Oliner, A. Ganapathi, and W. Xu, "Advances and challenges in log analysis," *Communications of the ACM*, vol. 55, no. 2, pp. 55–61, 2012.
- [46] R. Vaarandi, "A data clustering algorithm for mining patterns from event logs," in *Proceedings of the 3rd IEEE Workshop on IP Operations & Management (IPOM 2003)*(IEEE Cat. No. 03EX764). IEEE, 2003, pp. 119–126.
- [47] T. Davis and G. Shaw, *SQL Server Transaction Log Management*, ser. Stairways handbook. Red Gate Books, 2012. [Online]. Available: <https://books.google.ca/books?id=TLcVmAEACAAJ>
- [48] R. Beck, J. Stenum Czepluch, N. Lolluke, and S. Malone, "Blockchain—the gateway to trust-free cryptographic transactions," 2016.
- [49] "The Simple Logging Facade for Java (SLF4J)," [www.slf4j.org](http://www.slf4j.org), 2020.
- [50] B. Chen and Z. M. J. Jiang, "Studying the use of java logging utilities in the wild," 2020.
- [51] T. Mizouchi, K. Shimari, T. Ishio, and K. Inoue, "Padla: a dynamic log level adapter using online phase detection," in *Proceedings of the 27th International Conference on Program Comprehension*. IEEE Press, 2019, pp. 135–138.
- [52] "Apache Spark," <https://spark.apache.org/>, 2019.
- [53] J. MacQueen *et al.*, "Some methods for classification and analysis of multivariate observations," in *Proceedings of the fifth Berkeley symposium on mathematical statistics and probability*, vol. 1, no. 14. Oakland, CA, USA, 1967, pp. 281–297.
- [54] J. Zhu, S. He, J. Liu, P. He, Q. Xie, Z. Zheng, and M. R. Lyu, "Tools and benchmarks for automated log parsing," in *2019 IEEE/ACM 41st International Conference on Software Engineering: Software Engineering in Practice (ICSE-SEIP)*. IEEE, 2019, pp. 121–130.
- [55] D. Logothetis, C. Trezzo, K. C. Webb, and K. Yocum, "In-situ mapreduce for log processing," 2011.
- [56] J. Liu, J. Zhu, S. He, P. He, Z. Zheng, and M. R. Lyu, "Logzip: Extracting hidden structures via iterative clustering for log compression," in *2019 34th IEEE/ACM International Conference on Automated Software Engineering (ASE)*. IEEE, 2019, pp. 863–873.
- [57] A. Miransky, A. Hamou-Lhadj, E. Cialini, and A. Larsson, "Operational-log analysis for big data systems: Challenges and solutions," *IEEE Software*, vol. 33, no. 2, pp. 52–59, 2016.
- [58] B. H. Sigelman, L. A. Barroso, M. Burrows, P. Stephenson, M. Plakal, D. Beaver, S. Jaspan, and C. Shanbhag, "Dapper, a large-scale distributed systems tracing infrastructure," 2010.
- [59] R. Fonseca, G. Porter, R. H. Katz, and S. Shenker, "X-trace: A pervasive network tracing framework," in *4th {USENIX} Symposium on Networked Systems Design & Implementation ({NSDI} 07)*, 2007.
- [60] P. Barham, R. Isaacs, R. Mortier, and D. Narayanan, "Magpie: Online modelling and performance-aware systems." in *HotOS*, 2003, pp. 85–90.
- [61] M. K. Aguilera, J. C. Mogul, J. L. Wiener, P. Reynolds, and A. Muthitacharoen, "Performance debugging for distributed systems of black boxes," *ACM SIGOPS Operating Systems Review*, vol. 37, no. 5, pp. 74–89, 2003.
- [62] R. Wu, X. Xiao, S.-C. Cheung, H. Zhang, and C. Zhang, "Casper: An efficient approach to call trace collection," *ACM SIGPLAN Notices*, vol. 51, no. 1, pp. 678–690, 2016.
- [63] C. Wohlin, "Guidelines for snowballing in systematic literature studies and a replication in software engineering," in *Proceedings of the 18th international conference on evaluation and assessment in software engineering*, 2014, pp. 1–10.
- [64] F. Salfner, M. Lenk, and M. Malek, "A survey of online failure prediction methods," *ACM Computing Surveys (CSUR)*, vol. 42, no. 3, p. 10, 2010.
- [65] B. Chen and Z. M. J. Jiang, "A survey of software log instrumentation," *ACM Computing Surveys (CSUR)*, vol. 54, no. 4, pp. 1–34, 2021.
- [66] D. Yuan, S. Park, P. Huang, Y. Liu, M. M. Lee, X. Tang, Y. Zhou, and S. Savage, "Be conservative: enhancing failure diagnosis with proactive logging," in *Presented as part of the 10th {USENIX} Symposium on Operating Systems Design and Implementation ({OSDI} 12)*, 2012, pp. 293–306.
- [67] D. Yuan, J. Zheng, S. Park, Y. Zhou, and S. Savage, "Improving software diagnosability via log enhancement," *ACM Transactions on Computer Systems (TOCS)*, vol. 30, no. 1, p. 4, 2012.
- [68] W. Shang, Z. M. Jiang, B. Adams, A. E. Hassan, M. W. Godfrey, M. Nasser, and P. Flora, "An exploratory study of the evolution of communicated information about the execution of large software systems," *Journal of Software: Evolution and Process*, vol. 26, no. 1, pp. 3–26, 2014.
- [69] S. Kabinna, C.-P. Bezemer, W. Shang, M. D. Syer, and A. E. Hassan, "Examining the stability of logging statements," *Empirical Software Engineering*, vol. 23, no. 1, pp. 290–333, 2018.
- [70] "Datadog: Cloud Monitoring as a Service," <https://www.datadoghq.com/>, 2021.
- [71] "Fast, powerful searching over massive volumes of log data," <https://www.loggly.com/>, 2021.
- [72] "Dynatrace: The Leader in Cloud Monitoring," <https://www.dynatrace.com/>, 2021.
- [73] "NewRelic: Real-time insights for the modern enterprise," <https://newrelic.com/>, 2021.
- [74] "XpoLog: Log management & analysis automations," <http://www.xplg.com>, 2021.
- [75] B. Russo, G. Succi, and W. Pedrycz, "Mining system logs to learn error predictors: a case study of a telemetry system," *Empirical Software Engineering*, vol. 20, no. 4, pp. 879–927, 2015.
- [76] K. Yao, G. B. de Padua, W. Shang, C. Sporea, A. Toma, and S. Sajedi, "Log4perf: suggesting and updating logging locations for web-based systems' performance monitoring," *Empirical Software Engineering*, vol. 25, no. 1, pp. 488–531, 2020.
- [77] B. Chen and Z. M. J. Jiang, "Characterizing logging practices in java-based open source software projects—a replication study in apache software foundation," *Empirical Software Engineering*, vol. 22, no. 1, pp. 330–374, 2017.
- [78] W. Shang, M. Nagappan, and A. E. Hassan, "Studying the relationship between logging characteristics and the code quality of platform software," *Empirical Software Engineering*, vol. 20, no. 1, pp. 1–27, 2015.
- [79] S. Li, X. Niu, Z. Jia, X. Liao, J. Wang, and T. Li, "Guiding log revisions by learning from software evolution history," *Empirical Software Engineering*, pp. 1–39, 2019.
- [80] M. Hassani, W. Shang, E. Shihab, and N. Tsantalis, "Studying and detecting log-related issues," *Empirical Software Engineering*, vol. 23, no. 6, pp. 3248–3280, 2018.
- [81] H. Li, W. Shang, Y. Zou, and A. E. Hassan, "Towards just-in-time suggestions for log changes," *Empirical Software Engineering*, vol. 22, no. 4, pp. 1831–1865, 2017.
- [82] H. Li, W. Shang, and A. E. Hassan, "Which log level should developers choose for a new logging statement?" *Empirical Software Engineering*, vol. 22, no. 4, pp. 1684–1716, 2017.
- [83] K. Yao, H. Li, W. Shang, and A. E. Hassan, "A study of the performance of general compressors on log files," *Empirical Software Engineering*, pp. 3043–3085, 2020.
- [84] S. Chowdhury, S. Di Nardo, A. Hindle, and Z. M. J. Jiang, "An exploratory study on assessing the energy impact of logging on android applications," *Empirical Software Engineering*, vol. 23, no. 3, pp. 1422–1456, 2018.
- [85] Y. Zeng, J. Chen, W. Shang, and T.-H. P. Chen, "Studying the characteristics of logging practices in mobile apps: a case study on f-droid," *Empirical Software Engineering*, pp. 1–41, 2019.
- [86] M.-H. Lim, J.-G. Lou, H. Zhang, Q. Fu, A. B. J. Teoh, Q. Lin, R. Ding, and D. Zhang, "Identifying recurrent and unknown performance issues," in *2014 IEEE International Conference on Data Mining*. IEEE, 2014, pp. 320–329.
- [87] M. Du and F. Li, "Spell: Streaming parsing of system event logs," in *2016 IEEE 16th International Conference on Data Mining (ICDM)*. IEEE, 2016, pp. 859–864.
- [88] Z. Li, H. Li, T.-H. P. Chen, and W. Shang, "Deeply: Suggesting log levels using ordinal based neural networks," in *2021 IEEE/ACM 43rd International Conference on Software Engineering (ICSE)*. IEEE, 2021, pp. 1461–1472.
- [89] L. Yang, J. Chen, Z. Wang, W. Wang, J. Jiang, X. Dong, and W. Zhang, "Semi-supervised log-based anomaly detection via probabilistic label estimation," in *2021 IEEE/ACM 43rd Interna-*

- tional Conference on Software Engineering (ICSE)*. IEEE, 2021, pp. 1448–1460.
- [90] W. Shang, Z. M. Jiang, H. Hemmati, B. Adams, A. E. Hassan, and P. Martin, “Assisting developers of big data analytics applications when deploying on hadoop clouds,” in *2013 35th International Conference on Software Engineering (ICSE)*. IEEE, 2013, pp. 402–411.
- [91] S. Kabinna, C.-P. Bezemer, W. Shang, and A. E. Hassan, “Logging library migrations: a case study for the apache software foundation projects,” in *Mining Software Repositories (MSR), 2016 IEEE/ACM 13th Working Conference on*. IEEE, 2016, pp. 154–164.
- [92] J. Cândido, J. Haesen, M. Aniche, and A. van Deursen, “An exploratory study of log placement recommendation in an enterprise system,” in *2021 IEEE/ACM 18th International Conference on Mining Software Repositories (MSR) (MSR)*. Los Alamitos, CA, USA: IEEE Computer Society, may 2021, pp. 143–154. [Online]. Available: <https://doi.ieeecomputersociety.org/10.1109/MSR52588.2021.00027>
- [93] S. Gholamian and P. A. Ward, “On the Naturalness and Localness of Software Logs,” in *2021 IEEE/ACM 18th International Conference on Mining Software Repositories (MSR)*, 2021, pp. 155–166.
- [94] Z. Li, T.-H. P. Chen, J. Yang, and W. Shang, “Studying duplicate logging statements and their relationships with code clones,” *IEEE Transactions on Software Engineering*, 2021.
- [95] S. Locke, H. Li, T.-H. P. Chen, W. Shang, and W. Liu, “Logassist: Assisting log analysis through log summarization,” *IEEE Transactions on Software Engineering*, 2021.
- [96] H. Dai, H. Li, C. S. Chen, W. Shang, and T.-H. Chen, “Logram: Efficient log parsing using n-gram dictionaries,” *IEEE Transactions on Software Engineering*, 2020.
- [97] Z. Liu, X. Xia, D. Lo, Z. Xing, A. E. Hassan, and S. Li, “Which variables should i log?” *IEEE Transactions on Software Engineering*, 2019.
- [98] R. Chen, S. Zhang, D. Li, Y. Zhang, F. Guo, W. Meng, D. Pei, Y. Zhang, X. Chen, and Y. Liu, “Logtransfer: Cross-system log anomaly detection for software systems with transfer learning,” in *2020 IEEE 31st International Symposium on Software Reliability Engineering (ISSRE)*. IEEE, 2020, pp. 37–47.
- [99] A. Pecchia and S. Russo, “Detection of software failures through event logs: An experimental study,” in *2012 IEEE 23rd International Symposium on Software Reliability Engineering*. IEEE, 2012, pp. 31–40.
- [100] L. Bao, Q. Li, P. Lu, J. Lu, T. Ruan, and K. Zhang, “Execution anomaly detection in large-scale systems through console log analysis,” *Journal of Systems and Software*, vol. 143, pp. 172–186, 2018.
- [101] M. Farshchi, J.-G. Schneider, I. Weber, and J. Grundy, “Metric selection and anomaly detection for cloud operations using log and metric correlation analysis,” *Journal of Systems and Software*, vol. 137, pp. 531–549, 2018.
- [102] I. Mavridis and H. Karatza, “Performance evaluation of cloud-based log file analysis with apache hadoop and apache spark,” *Journal of Systems and Software*, vol. 125, pp. 133–151, 2017.
- [103] S. He, Q. Lin, J.-G. Lou, H. Zhang, M. R. Lyu, and D. Zhang, “Identifying impactful service system problems via log analysis,” in *Proceedings of the 2018 26th ACM Joint Meeting on European Software Engineering Conference and Symposium on the Foundations of Software Engineering*, 2018, pp. 60–70.
- [104] X. Zhang, Y. Xu, Q. Lin, B. Qiao, H. Zhang, Y. Dang, C. Xie, X. Yang, Q. Cheng, Z. Li *et al.*, “Robust log-based anomaly detection on unstable log data,” in *Proceedings of the 2019 27th ACM Joint Meeting on European Software Engineering Conference and Symposium on the Foundations of Software Engineering*, 2019, pp. 807–817.
- [105] Z. Li, T.-H. Chen, and W. Shang, “Where shall we log? studying and suggesting logging locations in code blocks,” in *2020 35th IEEE/ACM International Conference on Automated Software Engineering (ASE)*. IEEE, 2020, pp. 361–372.
- [106] B. Chen, J. Song, P. Xu, X. Hu, and Z. M. J. Jiang, “An automated approach to estimating code coverage measures via execution logs,” in *Proceedings of the 33rd ACM/IEEE International Conference on Automated Software Engineering*. ACM, 2018, pp. 305–316.
- [107] P. He, Z. Chen, S. He, and M. R. Lyu, “Characterizing the natural language descriptions in software logging statements,” in *2018 33rd IEEE/ACM International Conference on Automated Software Engineering (ASE)*. IEEE, 2018, pp. 178–189.
- [108] Z. Jia, S. Li, X. Liu, X. Liao, and Y. Liu, “Smartlog: Place error log statement by deep understanding of log intention,” in *2018 IEEE 25th International Conference on Software Analysis, Evolution and Reengineering (SANER)*. IEEE, 2018, pp. 61–71.
- [109] X. Zhao, Y. Zhang, D. Lion, M. F. Ullah, Y. Luo, D. Yuan, and M. Stumm, “lprof: A non-intrusive request flow profiler for distributed systems,” in *11th {USENIX} Symposium on Operating Systems Design and Implementation ({OSDI} 14)*, 2014, pp. 629–644.
- [110] D. Yuan, Y. Luo, X. Zhuang, G. R. Rodrigues, X. Zhao, Y. Zhang, P. U. Jain, and M. Stumm, “Simple testing can prevent most critical failures: An analysis of production failures in distributed data-intensive systems,” in *11th {USENIX} Symposium on Operating Systems Design and Implementation ({OSDI} 14)*, 2014, pp. 249–265.
- [111] X. Yu, P. Joshi, J. Xu, G. Jin, H. Zhang, and G. Jiang, “Cloudseer: Workflow monitoring of cloud infrastructures via interleaved logs,” vol. 44, no. 2, pp. 489–502, 2016.
- [112] X. Xu, L. Zhu, I. Weber, L. Bass, and D. Sun, “Pod-diagnosis: Error diagnosis of sporadic operations on cloud applications,” in *2014 44th Annual IEEE/IFIP International Conference on Dependable Systems and Networks*. IEEE, 2014, pp. 252–263.
- [113] A. J. Oliner and A. Aiken, “Online detection of multi-component interactions in production systems,” in *2011 IEEE/IFIP 41st International Conference on Dependable Systems & Networks (DSN)*. IEEE, 2011, pp. 49–60.
- [114] A. Oprea, Z. Li, T.-F. Yen, S. H. Chin, and S. Alrwais, “Detection of early-stage enterprise infection by mining large-scale log data,” in *2015 45th Annual IEEE/IFIP International Conference on Dependable Systems and Networks*. IEEE, 2015, pp. 45–56.
- [115] M. Cinque, D. Cotroneo, R. Natella, and A. Pecchia, “Assessing and improving the effectiveness of logs for the analysis of software faults,” in *2010 IEEE/IFIP International Conference on Dependable Systems & Networks (DSN)*. IEEE, 2010, pp. 457–466.
- [116] J.-G. Lou, Q. Fu, S. Yang, Y. Xu, and J. Li, “Mining invariants from console logs for system problem detection,” in *USENIX Annual Technical Conference*, 2010, pp. 23–25.
- [117] R. Ding, H. Zhou, J.-G. Lou, H. Zhang, Q. Lin, Q. Fu, D. Zhang, and T. Xie, “Log2: A cost-aware logging mechanism for performance diagnosis,” in *USENIX Annual Technical Conference*, 2015, pp. 139–150.
- [118] X. Fu, R. Ren, J. Zhan, W. Zhou, Z. Jia, and G. Lu, “Logmaster: Mining event correlations in logs of large-scale cluster systems,” in *2012 IEEE 31st Symposium on Reliable Distributed Systems*. IEEE, 2012, pp. 71–80.
- [119] B. Zhang, H. Zhang, P. Moscato, and A. Zhang, “Anomaly detection via mining numerical workflow relations from logs,” in *2020 International Symposium on Reliable Distributed Systems (SRDS)*. IEEE, 2020, pp. 195–204.
- [120] N. Gurumdimma, A. Jhumka, M. Liakata, E. Chuah, and J. Browne, “Crude: Combining resource usage data and error logs for accurate error detection in large-scale distributed systems,” in *2016 IEEE 35th Symposium on Reliable Distributed Systems (SRDS)*. IEEE, 2016, pp. 51–60.
- [121] E. Chuah, A. Jhumka, S. Narasimhamurthy, J. Hammond, J. C. Browne, and B. Barth, “Linking resource usage anomalies with system failures from cluster log data,” in *2013 IEEE 32nd International Symposium on Reliable Distributed Systems*. IEEE, 2013, pp. 111–120.
- [122] R. Marty, “Cloud application logging for forensics,” in *proceedings of the 2011 ACM Symposium on Applied Computing*, 2011, pp. 178–184.
- [123] D. Shin, D. Bianculli, and L. Briand, “Effective removal of operational log messages: an application to model inference,” *arXiv preprint arXiv:2004.07194*, 2020.
- [124] S. He, J. Zhu, P. He, and M. R. Lyu, “Loghub: a large collection of system log datasets towards automated log analytics,” *arXiv preprint arXiv:2008.06448*, 2020.
- [125] S. Di, H. Guo, R. Gupta, E. R. Pershey, M. Snir, and F. Cappello, “Exploring properties and correlations of fatal events in a large-scale hpc system,” *IEEE Transactions on Parallel and Distributed Systems*, vol. 30, no. 2, pp. 361–374, 2018.
- [126] T. Li, W. Peng, C. Perng, S. Ma, and H. Wang, “An integrated data-driven framework for computing system management,” *IEEE Transactions on Systems, Man, and Cybernetics-Part A: Systems and Humans*, vol. 40, no. 1, pp. 90–99, 2010.
- [127] S. Huang, Y. Liu, C. Fung, R. He, Y. Zhao, H. Yang, and Z. Luan, “Hit anomaly: Hierarchical transformers for anomaly detection in

- system log," *IEEE Transactions on Network and Service Management*, vol. 17, no. 4, pp. 2064–2076, 2020.
- [128] T. Kim, S. Kim, S. Park, and Y. Park, "Automatic recommendation to appropriate log levels," *Software: Practice and Experience*, vol. 50, no. 3, pp. 189–209, 2020.
- [129] D.-Q. Zou, H. Qin, and H. Jin, "Uilog: Improving log-based fault diagnosis by log analysis," *Journal of computer science and technology*, vol. 31, no. 5, pp. 1038–1052, 2016.
- [130] E. Chuah, S.-h. Kuo, P. Hiew, W.-C. Tjhi, G. Lee, J. Hammond, M. T. Michalewicz, T. Hung, and J. C. Browne, "Diagnosing the root-causes of failures from cluster log files," in *2010 International Conference on High Performance Computing*. IEEE, 2010, pp. 1–10.
- [131] N. Taerat, J. Brandt, A. Gentile, M. Wong, and C. Leangsuksun, "Baler: deterministic, lossless log message clustering tool," *Computer Science-Research and Development*, vol. 26, no. 3, pp. 285–295, 2011.
- [132] W. Meng, Y. Liu, Y. Zhu, S. Zhang, D. Pei, Y. Liu, Y. Chen, R. Zhang, S. Tao, P. Sun *et al.*, "Loganomaly: Unsupervised detection of sequential and quantitative anomalies in unstructured logs," in *IJCAI*, vol. 7, 2019, pp. 4739–4745.
- [133] L. Tang, T. Li, and C.-S. Perng, "Logsig: Generating system events from raw textual logs," in *Proceedings of the 20th ACM International Conference on Information and Knowledge Management*, ser. CIKM '11. New York, NY, USA: ACM, 2011, pp. 785–794. [Online]. Available: <http://doi.acm.org/10.1145/2063576.2063690>
- [134] T. Li, Y. Jiang, C. Zeng, B. Xia, Z. Liu, W. Zhou, X. Zhu, W. Wang, L. Zhang, J. Wu *et al.*, "Flap: An end-to-end event log analysis platform for system management," in *Proceedings of the 23rd ACM SIGKDD International Conference on Knowledge Discovery and Data Mining*, 2017, pp. 1547–1556.
- [135] T. Qiu, Z. Ge, D. Pei, J. Wang, and J. Xu, "What happened in my network: mining network events from router syslogs," in *Proceedings of the 10th ACM SIGCOMM conference on Internet measurement*, 2010, pp. 472–484.
- [136] M. Awad and D. A. Menascé, "Performance model derivation of operational systems through log analysis," in *2016 IEEE 24th International Symposium on Modeling, Analysis and Simulation of Computer and Telecommunication Systems (MASCOTS)*. IEEE, 2016, pp. 159–168.
- [137] R. Tang and Y. Zou, "An approach for mining web service composition patterns from execution logs," in *2010 12th IEEE International Symposium on Web Systems Evolution (WSE)*. IEEE, 2010, pp. 53–62.
- [138] P. Zhou, Y. Wang, Z. Li, X. Wang, G. Tyson, and G. Xie, "Logsayer: Log pattern-driven cloud component anomaly diagnosis with machine learning," in *2020 IEEE/ACM 28th International Symposium on Quality of Service (IWQoS)*. IEEE, 2020, pp. 1–10.
- [139] P. He, J. Zhu, Z. Zheng, and M. R. Lyu, "Drain: An online log parsing approach with fixed depth tree," in *2017 IEEE International Conference on Web Services (ICWS)*. IEEE, 2017, pp. 33–40.
- [140] S. Messaoudi, A. Panichella, D. Bianculli, L. Briand, and R. Sasnauskas, "A search-based approach for accurate identification of log message formats," in *2018 IEEE/ACM 26th International Conference on Program Comprehension (ICPC)*. IEEE, 2018, pp. 167–16710.
- [141] H. Anu, J. Chen, W. Shi, J. Hou, B. Liang, and B. Qin, "An approach to recommendation of verbosity log levels based on logging intention," in *2019 IEEE International Conference on Software Maintenance and Evolution (ICSME)*. IEEE, 2019, pp. 125–134.
- [142] K. Yao, G. B. de Pádua, W. Shang, S. Sporea, A. Toma, and S. Sajedi, "Log4perf: Suggesting logging locations for web-based systems' performance monitoring," in *Proceedings of the 2018 ACM/SPEC International Conference on Performance Engineering*. ACM, 2018, pp. 127–138.
- [143] L. Zeng, Y. Xiao, and H. Chen, "Linux auditing: overhead and adaptation," in *2015 IEEE International Conference on Communications (ICC)*. IEEE, 2015, pp. 7168–7173.
- [144] X. Xu, I. Weber, L. Bass, L. Zhu, H. Wada, and F. Teng, "Detecting cloud provisioning errors using an annotated process model," in *Proceedings of the 8th Workshop on Middleware for Next Generation Internet Computing*. ACM, 2013, p. 5.
- [145] C. Zhang, Z. Guo, M. Wu, L. Lu, Y. Fan, J. Zhao, and Z. Zhang, "Autolog: facing log redundancy and insufficiency," in *Proceedings of the Second Asia-Pacific Workshop on Systems*. ACM, 2011, p. 10.
- [146] M. Salman, B. Welch, D. Raymond, R. Marchany, and J. Tront, "Designing pelhstat: Big data analytics for system event logs." HICSS Symposium on Cybersecurity Big Data Analytics, 2017.
- [147] S. Lal, N. Sardana, and A. Sureka, "Logoptplus: Learning to optimize logging in catch and if programming constructs," in *2016 IEEE 40th Annual Computer Software and Applications Conference (COMPSAC)*, vol. 1. IEEE, 2016, pp. 215–220.
- [148] W. Shang, M. Nagappan, A. E. Hassan, and Z. M. Jiang, "Understanding log lines using development knowledge," in *Software Maintenance and Evolution (ICSME), 2014 IEEE International Conference on*. IEEE, 2014, pp. 21–30.
- [149] G. Kiczales, "J. lamping, a. mendhekar, c. maeda, c. lopes, j.-m. loingtier, and j. irwin. aspect-oriented programming," *Lecture notes in Computer Science, ECOOP*, pp. 220–242, 1997.
- [150] "The AspectJ Project," <https://eclipse.org/aspectj/>, 2019.
- [151] L. Tan, D. Yuan, G. Krishna, and Y. Zhou, "/\* icomment: Bugs or bad comments?\*", in *Proceedings of twenty-first ACM SIGOPS symposium on Operating systems principles*, 2007, pp. 145–158.
- [152] C. Zhi, J. Yin, S. Deng, M. Ye, M. Fu, and T. Xie, "An exploratory study of logging configuration practice in java," in *2019 IEEE International Conference on Software Maintenance and Evolution (IC-SME)*. IEEE, 2019, pp. 459–469.
- [153] "Apache Software Foundation," [www.apache.org](http://www.apache.org), 2020.
- [154] W. Shang, Z. M. Jiang, B. Adams, A. E. Hassan, M. W. Godfrey, M. Nasser, and P. Flora, "An exploratory study of the evolution of communicated information about the execution of large software systems," in *2011 18th Working Conference on Reverse Engineering*. IEEE, 2011, pp. 335–344.
- [155] S. Kabinna, W. Shang, C.-P. Bezemer, and A. E. Hassan, "Examining the stability of logging statements," in *2016 IEEE 23rd International Conference on Software Analysis, Evolution, and Reengineering (SANER)*, vol. 1. IEEE, 2016, pp. 326–337.
- [156] S. Li, X. Niu, Z. Jia, J. Wang, H. He, and T. Wang, "Logtracker: learning log revision behaviors proactively from software evolution history," in *Proceedings of the 26th Conference on Program Comprehension*, 2018, pp. 178–188.
- [157] G. Rong, Y. Xu, S. Gu, H. Zhang, and D. Shao, "Can you capture information as you intend to? a case study on logging practice in industry," in *2020 IEEE International Conference on Software Maintenance and Evolution (ICSME)*. IEEE, 2020, pp. 12–22.
- [158] Z. Li, T.-H. Chen, J. Yang, and W. Shang, "Dlfinder: Characterizing and detecting duplicate logging code smells," in *2019 IEEE/ACM 41st International Conference on Software Engineering (ICSE)*. IEEE, 2019, pp. 152–163.
- [159] "Jira — Issue and Project Tracking Software," <https://www.atlassian.com/software/jira>, 2020.
- [160] M. Zhang, T. Hall, and N. Baddoo, "Code bad smells: a review of current knowledge," *Journal of Software Maintenance and Evolution: research and practice*, vol. 23, no. 3, pp. 179–202, 2011.
- [161] S. He, J. Zhu, P. He, and M. R. Lyu, "Experience report: System log analysis for anomaly detection," in *2016 IEEE 27th International Symposium on Software Reliability Engineering (ISSRE)*, Oct 2016, pp. 207–218.
- [162] S. Lal and A. Sureka, "Logopt: Static feature extraction from source code for automated catch block logging prediction," in *Proceedings of the 9th India Software Engineering Conference*. ACM, 2016, pp. 151–155.
- [163] V. Saini, F. Farmahinifarahani, Y. Lu, P. Baldi, and C. V. Lopes, "Oreo: Detection of clones in the twilight zone," in *Proceedings of the 2018 26th ACM Joint Meeting on European Software Engineering Conference and Symposium on the Foundations of Software Engineering*, 2018, pp. 354–365.
- [164] Y. Huang, X. Hu, N. Jia, X. Chen, Y. Xiong, and Z. Zheng, "Learning code context information to predict comment locations," *IEEE Transactions on Reliability*, 2019.
- [165] E. A. Freeman and G. G. Moisen, "A comparison of the performance of threshold criteria for binary classification in terms of predicted prevalence and kappa," *Ecological modelling*, vol. 217, no. 1-2, pp. 48–58, 2008.
- [166] M. Aly, "Survey on multiclass classification methods," *Neural Netw*, vol. 19, pp. 1–9, 2005.
- [167] L. Li and H.-T. Lin, "Ordinal regression by extended binary classification," 2007.
- [168] M. W. Browne, "Cross-validation methods," *Journal of mathematical psychology*, vol. 44, no. 1, pp. 108–132, 2000.
- [169] K. Papineni, S. Roukos, T. Ward, and W.-J. Zhu, "Bleu: a method for automatic evaluation of machine translation," in *Proceedings*

- of the 40th annual meeting on association for computational linguistics. Association for Computational Linguistics, 2002, pp. 311–318.
- [170] C.-Y. Lin, “Rouge: A package for automatic evaluation of summaries,” *Text Summarization Branches Out*, 2004.
- [171] S. Zhang, I. Cohen, M. Goldszmidt, J. Symons, and A. Fox, “Ensembles of models for automated diagnosis of system performance problems,” in *2005 International Conference on Dependable Systems and Networks (DSN’05)*. IEEE, 2005, pp. 644–653.
- [172] J. H. Andrews, “Testing using log file analysis: tools, methods, and issues,” in *Proceedings 13th IEEE International Conference on Automated Software Engineering (Cat. No. 98EX239)*. IEEE, 1998, pp. 157–166.
- [173] K. H. Lee, X. Zhang, and D. Xu, “Loggc: garbage collecting audit log,” in *Proceedings of the 2013 ACM SIGSAC conference on Computer & communications security*, 2013, pp. 1005–1016.
- [174] “OpenStack Fault Injection Dataset,” <https://github.com/dessertlab/Fault-Injection-Dataset>, 2021.
- [175] P. Skibiński and J. Swacha, “Fast and efficient log file compression,” in *proceedings of 11th east-European conference on advances in databases and information systems (ADBIS)*, 2007, pp. 330–342.
- [176] D. Cotroneo, L. De Simone, P. Liguori, R. Natella, and N. Bidokhti, “How bad can a bug get? an empirical analysis of software failures in the openstack cloud computing platform,” in *Proceedings of the 2019 27th ACM Joint Meeting on European Software Engineering Conference and Symposium on the Foundations of Software Engineering*, 2019, pp. 200–211.
- [177] A. Hassan, D. Martin, P. Flora, P. Mansfield, and D. Dietz, “An industrial case study of customizing operational profiles using log compression,” in *2008 ACM/IEEE 30th International Conference on Software Engineering*. IEEE, 2008, pp. 713–723.
- [178] M. Lemoudden and B. El Ouahidi, “Managing cloud-generated logs using big data technologies,” in *2015 International Conference on Wireless Networks and Mobile Communications (WINCOM)*. IEEE, 2015, pp. 1–7.
- [179] “Logback Logging Framework,” <http://logback.qos.ch/>, 2020.
- [180] “Log4j Appenders,” <https://logging.apache.org/log4j/2.x/manual/appenders.html>, 2021.
- [181] C.-S. Perng, D. Thoenen, G. Grabarnik, S. Ma, and J. Hellerstein, “Data-driven validation, completion and construction of event relationship networks,” in *Proceedings of the ninth ACM SIGKDD international conference on Knowledge discovery and data mining*, 2003, pp. 729–734.
- [182] R. Conforti, M. La Rosa, and A. H. ter Hofstede, “Filtering out infrequent behavior from business process event logs,” *IEEE Transactions on Knowledge and Data Engineering*, vol. 29, no. 2, pp. 300–314, 2016.
- [183] X. Sun, W. Hou, D. Yu, J. Wang, and J. Pan, “Filtering out noise logs for process modelling based on event dependency,” in *2019 IEEE International Conference on Web Services (ICWS)*. IEEE, 2019, pp. 388–392.
- [184] H. Mi, H. Wang, Y. Zhou, M. R.-T. Lyu, and H. Cai, “Toward fine-grained, unsupervised, scalable performance diagnosis for production cloud computing systems,” *IEEE Transactions on Parallel and Distributed Systems*, vol. 24, no. 6, pp. 1245–1255, 2013.
- [185] Q. Lin, H. Zhang, J.-G. Lou, Y. Zhang, and X. Chen, “Log clustering based problem identification for online service systems,” in *Proceedings of the 38th International Conference on Software Engineering Companion*. ACM, 2016, pp. 102–111.
- [186] P. He, J. Zhu, S. He, J. Li, and M. R. Lyu, “An evaluation study on log parsing and its use in log mining,” in *2016 46th annual IEEE/IFIP international conference on dependable systems and networks (DSN)*. IEEE, 2016, pp. 654–661.
- [187] K. Deb, A. Pratap, S. Agarwal, and T. Meyarivan, “A fast and elitist multiobjective genetic algorithm: Nsga-ii,” *IEEE transactions on evolutionary computation*, vol. 6, no. 2, pp. 182–197, 2002.
- [188] D. El-Masri, F. Petrillo, Y.-G. Guéhéneuc, A. Hamou-Lhadj, and A. Bouziane, “A systematic literature review on automated log abstraction techniques,” *Information and Software Technology*, vol. 122, p. 106276, 2020.
- [189] M. Nagappan, K. Wu, and M. A. Vouk, “Efficiently extracting operational profiles from execution logs using suffix arrays,” in *2009 20th International Symposium on Software Reliability Engineering*. IEEE, 2009, pp. 41–50.
- [190] “LogPai Log Parse Benchmark,” <https://github.com/logpai/logparser>, 2021.
- [191] J. L. Hammond, T. Minyard, and J. Browne, “End-to-end framework for fault management for open source clusters: Ranger,” in *Proceedings of the 2010 TeraGrid Conference*, 2010, pp. 1–6.
- [192] Y. Shen, E. Mariconti, P. A. Vervier, and G. Stringhini, “Tiresias: Predicting security events through deep learning,” in *Proceedings of the 2018 ACM SIGSAC Conference on Computer and Communications Security*, 2018, pp. 592–605.
- [193] M. Farshchi, J.-G. Schneider, I. Weber, and J. Grundy, “Experience report: Anomaly detection of cloud application operations using log and cloud metric correlation analysis,” in *Software Reliability Engineering (ISSRE), 2015 IEEE 26th International Symposium on*. IEEE, 2015, pp. 24–34.
- [194] J. Kennedy and R. Eberhart, “Particle swarm optimization,” in *Proceedings of ICNN’95-international conference on neural networks*, vol. 4. IEEE, 1995, pp. 1942–1948.
- [195] A. Vaswani, N. Shazeer, N. Parmar, J. Uszkoreit, L. Jones, A. N. Gomez, L. Kaiser, and I. Polosukhin, “Attention is all you need,” *arXiv preprint arXiv:1706.03762*, 2017.
- [196] J. Pennington, R. Socher, and C. D. Manning, “Glove: Global vectors for word representation,” in *Proceedings of the 2014 conference on empirical methods in natural language processing (EMNLP)*, 2014, pp. 1532–1543.
- [197] S. Di, R. Gupta, M. Snir, E. Pershey, and F. Cappello, “Logaidler: A tool for mining potential correlations of hpc log events,” in *2017 17th IEEE/ACM International Symposium on Cluster, Cloud and Grid Computing (CCGRID)*. IEEE, 2017, pp. 442–451.
- [198] “Mira System,” <https://www.alcf.anl.gov/alcf-resources/mira>, 2020.
- [199] B. L. Welch, “The generalization of student’s problem when several different population variances are involved,” *Biometrika*, vol. 34, no. 1/2, pp. 28–35, 1947.
- [200] D. Heckerman, D. M. Chickering, C. Meek, R. Rounthwaite, and C. Kadie, “Dependency networks for inference, collaborative filtering, and data visualization,” *Journal of Machine Learning Research*, vol. 1, no. Oct, pp. 49–75, 2000.
- [201] N. Sorkunlu, V. Chandola, and A. Patra, “Tracking system behavior from resource usage data,” in *2017 IEEE International Conference on Cluster Computing (CLUSTER)*. IEEE, 2017, pp. 410–418.
- [202] “TPC Benchmark,” <http://www.tpc.org/tpcw/>, 2019.
- [203] W. Dong, L. Luo, and C. Huang, “Dynamic logging with dylog in networked embedded systems,” *ACM Transactions on Embedded Computing Systems (TECS)*, vol. 15, no. 1, pp. 1–25, 2015.
- [204] A. Gomez, L. Sigrist, T. Schalch, L. Benini, and L. Thiele, “Efficient, long-term logging of rich data sensors using transient sensor nodes,” *ACM Transactions on Embedded Computing Systems (TECS)*, vol. 17, no. 1, pp. 1–23, 2017.
- [205] W. Wang and D. Zhao, “Extracting traffic primitives directly from naturally logged data for self-driving applications,” *IEEE Robotics and Automation Letters*, vol. 3, no. 2, pp. 1223–1229, 2018.
- [206] A. Hindle, A. Wilson, K. Rasmussen, E. J. Barlow, J. C. Campbell, and S. Romansky, “Greenminer: A hardware based mining software repositories software energy consumption framework,” in *Proceedings of the 11th working conference on mining software repositories*, 2014, pp. 12–21.
- [207] S. Yang, S. J. Park, and J. Ousterhout, “Nanolog: a nanosecond scale logging system,” in *2018 {USENIX} Annual Technical Conference ({USENIX}{ATC} 18)*, 2018, pp. 335–350.
- [208] M. Marron, “Log++ logging for a cloud-native world,” in *Proceedings of the 14th ACM SIGPLAN International Symposium on Dynamic Languages*, 2018, pp. 25–36.
- [209] F. Rivera-Ortiz and L. Pasquale, “Towards automated logging for forensic-ready software systems,” in *2019 IEEE 27th International Requirements Engineering Conference Workshops (REW)*. IEEE, 2019, pp. 157–163.
- [210] B. Chen and Z. M. J. Jiang, “Extracting and studying the logging-code-issue-introducing changes in java-based large-scale open source software systems,” *Empirical Software Engineering*, vol. 24, no. 4, pp. 2285–2322, 2019.
- [211] Y. Liang, Y. Zhang, H. Xiong, and R. Sahoo, “Failure prediction in ibm bluegene/l event logs,” in *Data Mining, 2007. ICDM 2007. Seventh IEEE International Conference on*. IEEE, 2007, pp. 583–588.
- [212] P. He, J. Zhu, S. He, J. Li, and M. R. Lyu, “Towards automated log parsing for large-scale log data analysis,” *IEEE Transactions on Dependable and Secure Computing*, vol. 15, no. 6, pp. 931–944, 2017.

- [213] D. Ogle, H. Kreger, A. Salahshour, J. Cornpropst, E. Labadie, M. Chessell, B. Horn, J. Gerken, J. Schoech, and M. Wamboldt, "Canonical situation data format: The common base event v1.0.1," *International Business Machines Corporation*, 2004.
- [214] A. Hindle, E. T. Barr, Z. Su, M. Gabel, and P. Devanbu, "On the naturalness of software," in *2012 34th International Conference on Software Engineering (ICSE)*. IEEE, 2012, pp. 837–847.
- [215] Z. Tu, Z. Su, and P. Devanbu, "On the localness of software," in *Proceedings of the 22nd ACM SIGSOFT International Symposium on Foundations of Software Engineering*, 2014, pp. 269–280.
- [216] A. Rabkin, W. Xu, A. Wildani, A. Fox, D. A. Patterson, and R. H. Katz, "A graphical representation for identifier structure in logs." in *SLAML*, 2010.
- [217] S. Cao, X. Di, Y. Gong, W. Ren, and X. Zhang, "Knowledge extraction and knowledge graph construction based on campus security logss," in *International Conference on Artificial Intelligence and Security*. Springer, 2020, pp. 354–364.
- [218] L. Ehrlinger and W. Wöß, "Towards a definition of knowledge graphs." *SEMANTICS (Posters, Demos, SuCCESS)*, vol. 48, pp. 1–4, 2016.
- [219] J. Devlin, M.-W. Chang, K. Lee, and K. Toutanova, "Bert: Pre-training of deep bidirectional transformers for language understanding," *arXiv preprint arXiv:1810.04805*, 2018.



**Sina Gholamian** is a Ph.D. student in software engineering at the University of Waterloo, Canada. His research interests include application of machine learning and data mining approaches for designing and improving automated software systems. His prior work has been published at premier venues such as ASE, MSR, SRDS, and ACM SAC.



**Paul A. S. Ward** is an associate professor at the University of Waterloo, Canada. He is also a faculty fellow at the IBM Centre for Advanced Studies. His expertise lies in the area of distributed systems and computer networks.