

Secure Source Coding with Side-information at Decoder and Shared Key at Encoder and Decoder

Hamid Ghourchian, Photios A. Stavrou, Tobias J. Oechtering,
and Mikael Skoglund

Abstract

We study the problem of rate-distortion-equivocation with side-information only available at the decoder when an independent private random key is shared between the sender and the receiver. The sender compresses the sequence, and the receiver reconstructs it such that the average distortion between the source and the output is limited. The equivocation is measured at an eavesdropper that intercepts the source encoded message, utilizing side-information correlated with the source and the side-information at the decoder. We have derived the entire achievable rate-distortion-equivocation region for this problem.

Keywords— Source coding, rate-distortion, security, side-information, shared key.

1 Introduction

In this paper, we consider a source (sequence of random variables (RVs)) that is given to the sender. The receiver does not have access to the source, but it has access to a correlated sequence of RVs that serves as side-information (SI). In addition, both the sender and the receiver have access to a secure sequence of random bits (shared-key). The encoder at the sender, compresses the source using the shared-key such that the legitimate receiver is able to estimate the source using the SI and the shared-key, with some limited distortion. In our setup, there exists a passive eavesdropper who has access to the output of the encoder and a possibly different SI, as depicted in Fig. 1. The goal is to minimize the output rate of the encoder while the distortion between the source and its estimated value, as well as the leaked information from the source to eavesdropper, are limited. This setup is a special case of a more general setup when all the sender, receiver, and the eavesdropper have different versions of SI. Here, the shared-key can be considered as the common SI between sender and receiver that is not available to the eavesdropper.

This is a long version of the accepted ITW 2021 paper. This work was supported in part by the Swedish Strategic Research Foundation.

The authors are with the Department of Intelligent Systems, Division of Information Science and Engineering, at KTH Royal Institute of Technology, 10044 Stockholm, Sweden (e-mail: {hamidgh; fstavrou; oech; skoglund}@kth.se).

1.1 Literature Review

Classical rate-distortion theory was introduced by Shannon in [1]. It identified the trade-off between the minimum achievable distortion and the rate of non-causal encoder and decoder pair. For a complete overview, one can see, for instance, [2].

Shannon introduced the notion of communication secrecy from an information-theoretical perspective in [3]. During the 70s, Wyner introduced the wiretap channel [4] and showed that it is possible to send information at a positive rate with perfect secrecy when eavesdropper's channel is a degraded version of the channel from the encoder to the decoder. When it comes to secrecy using information-theoretic tools, often two approaches can be found in the literature. The first one presupposes that both encoder and decoder agree on a secret key before the transmission. The second one assumes that the decoder and the eavesdropper (sometimes the encoder as well) have different versions of SI, and thereby secrecy is achieved through this difference. For instance, Shannon in [3] adopted the first approach and showed that the transmission of a discrete memoryless source is entirely secure if the rate of the key is at least as large as the entropy of the source. Yamamoto in [5] studied various secure source coding scenarios that include, among other results, an extension of Shannon's cipher system to combine secrecy with rate-distortion theory.

Prabhakaran and Ramchandran in [6] considered lossless source coding with SI at both the decoder and the eavesdropper when there is no rate constraint between the encoder and the decoder. Gunduz et al. in [7], the authors considered a setup with SI at the encoder and coded SI at the decoder. Villard and Piantanida in [8] studied the problem of secure lossy source coding when one or both the receiver and the eavesdropper have SI (Fig. 2 with $W = \emptyset$). Chia and Kittichokechai in [9] adopt a setup where there exists a common SI at the sender and the receiver, while the SI of the eavesdropper can be different (Fig. 2 with $W = Y$). They showed that under certain Markov chain assumptions, or log-loss distortion, the rate-distortion-equivocation region has a closed-form solution.

In a different direction where delay constraints may appear in the system, Kaspi and Merhav in [10] considered two source coding models combining causal or zero-delay source coding under secrecy constraints. The causal source coding was defined in [11]. Ghourchian et al. in [12] considered secure lossy and lossless compression with sequential encoding and non-sequential decoding, such that the rates and equivocations are defined cumulatively over sequential blocks. They characterized the achievable rate profile-distortion-equivocation profile region.

There exist different approaches to characterize and obtain the leakage in source coding problems. For instance, Song et al. in [13] defined a distortion-based equivocation; for lossless case, when the receiver's SI is more capable, the rate-equivocation region is found. Schieler and Cuff in [14] studied the lossy case of [13] under the assumption that both the transmitter and the receiver share a secret key, but the receiver does not have access to the SI (Fig. 2 with $W^n = Y^n = K$ which is a secret independent key and different L which is a kind of additive distortion). Kittichokechai et al. in [15], studied the leakage from the output of the decoder to the eavesdropper instead of the leakage from the source to the eavesdropper (end-user privacy). SI exists at the decoder and the eavesdropper. In some cases, such as the one that the estimation of the input should only be memoryless with respect to the SI

and the message, the complete region is identified.

Secure source coding with multiple nodes has also been studied in recent years. The authors of [16] have studied the problem in which there exists a sender, two distributed receivers, one of which has a SI. The goal is to maximize the equivocation of the SI given the message sent to the receivers. In [17], there are two distributed but correlated sources, each of which should be estimated, with limited distortion, at the same decoder, while the eavesdropper also has access to a SI. The equivocation region of the two sources is desired. In the CEO problem, two different noisy observations of the same source are observed by distributed agents. They compress their observations such that the decoder is able to estimate the source [18, Section 12.4]. The CEO problem with secrecy constraints has been studied in [19], such that the eavesdropper knows the description of one of the agents.

Secure source coding with a helper node has also been studied. The helper receives the description from another node, usually the encoder. Then compresses the description, possibly with the help of SI, and then sends the output to the decoder. Since there is also a direct link, it is called *triangular helper* [20]. In [20], all sender, receiver, and the helper has a SI and the helper's input and SI is observed by the eavesdropper. The rate-distortion-equivocation region is known for some special Markov chains among the SI of nodes. The authors have also studied the problem in which the helper does not receive any description but has access to a different SI, and the eavesdropper knows the output. If the output of the helper is available at the encoder, the region is known; otherwise, only for some special cases, it has been proven. The problem of the triangular helper when the message to the helper and the receiver are the same has been studied in [21]. In [22], the source is made of two parts, and the channel between the encoder and the helper has infinite capacity but is observed by an eavesdropper. There is no SI at the receiver nor the eavesdropper, and the distortion is only dependent on the first source.

There are some approaches with an action-based encoder, such as [23], in which SIs exist at the eavesdropper and the decoder. However, the SIs can be changed by an action taken by another decoder with some cost. In some cases, the whole region is found.

1.2 Contribution

As the main contribution, we characterize the achievable rate-distortion-equivocation region of the setup in Fig. 1, entirely. We use two-level encoding similar to [8]. The key is employed as a one-time pad, first protecting the second level of the encoded message, and then if key-rate is still available, the first part will be secured. Interestingly, at the beginning of protecting the second part, the equivocation does not improve since the eavesdropper has SI, which is better for decoding that part. Additionally, we show that from our framework, we can recover the lossless source coding, the setup with no shared-key, and the setup with no SI. This setup has not been studied to the best of our knowledge, and the close studied setups are [8], in which there is no shared-key between the encoder and the decoder; [9], by assuming the same SI between the sender and the receiver is the shared-key, so, there is no SI at the decoder; [14], in which there is no SI at the decoder and the notion of leakage is different; and [10] in which the causal source coding and leakage have been considered, which results in a different perspective.

1.3 Organization

This article is structured as follows. We explain the notations used in this paper in the remainder of this section. In Section 2, we define the problem formally. In Section 3, we state our main result. We identify our results for some special cases, such as lossless reconstruction, and compare them to the known results in Section 4. Finally, we draw conclusions in Section 5. The proofs are in the appendix.

1.4 Notation

- Sets, random variables (RVs) and their realizations are denoted by calligraphic, capital and lower case letters, respectively. The set of integer, rational and real numbers are denoted by \mathbb{N} , \mathbb{Q} and \mathbb{R} , respectively. The set $\{1, \dots, k\}$ for some $k \in \mathbb{N}$ is denoted by $[k]$.
- The probability mass function (PMF) of an RV X with realizations $X = x$ defined on some alphabet \mathcal{X} of finite cardinality $|\mathcal{X}|$ is denoted by $p_X(x)$ or just $p(x)$. Similarly, for two RVs X and Y , the conditional PMF of Y given $X = x$ is denoted by $p_{Y|X}(y|x)$ or just $p(y|x)$. The notation $\mathbb{E}[X]$ means the expected value of RV X . The notation $X \perp\!\!\!\perp Y$ means X is independent of Y .
- Random PMFs are denoted by capital letter P . For instance, a random PMF for a RV X with realization x is denoted by $P_X(x)$, or just $P(x)$. Formally, it is equal to $p(x|B)$, where B is a random object. The random object B can be understood from the context. In our framework, B is always all the random binning functions in the system (note that it is the binning function, not the bin index).
- The sequence $(x_m, x_{m+1}, \dots, x_n)$, for $m, n \in \mathbb{N}$, is denoted by x_m^n . If $m = 1$, we may use the notation x^n instead of x_1^n . Also, x^0 means \emptyset .
- $\mathbb{I}\{\mathcal{E}\}$ is a function of an event \mathcal{E} . It is equal to 1 if the event \mathcal{E} occurs, and 0 otherwise.
- The norm 1 distance between two PMFs $p(x)$ and $q(x)$ is denoted by $\|p(x) - q(x)\|_1$, or just $\|p - q\|_1$ which is equal to $\sum_{x \in \mathcal{X}} |p(x) - q(x)|$.
- All logarithms are in base 2 unless otherwise stated. The term “w.r.t.” stands for “with respect to”.

2 Problem Statement

Our setup is illustrated in Fig. 1. In that setup, an independent key K with rate R_0 is shared between the encoder and the decoder, whereas the decoder has additional access to some SI Y^n . The eavesdropper has access to the SI Z^n . The goal is to find the rate-distortion-leakage region of the source X^n . Next, we formally define the problem.

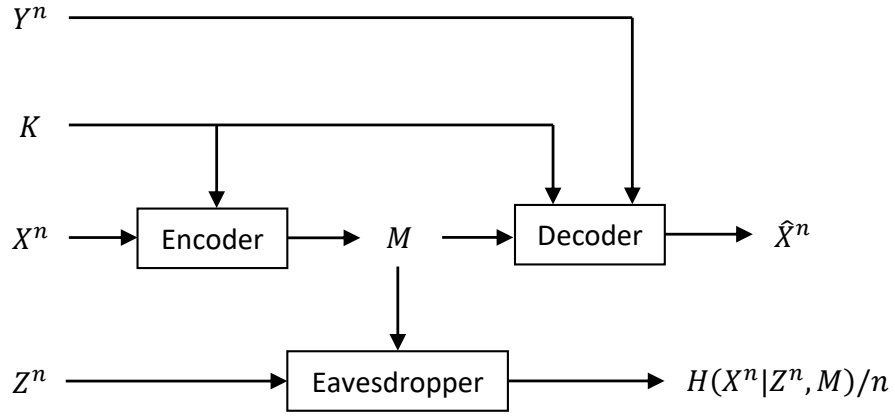

Figure 1: The sender encodes the source X^n using the shared key K , and the receiver decodes the index M utilizing the SI Y^n and K . The eavesdropper has access to the index M and SI Z^n and the equivocation is measured by $H(X^n | Z^n, M)/n$.

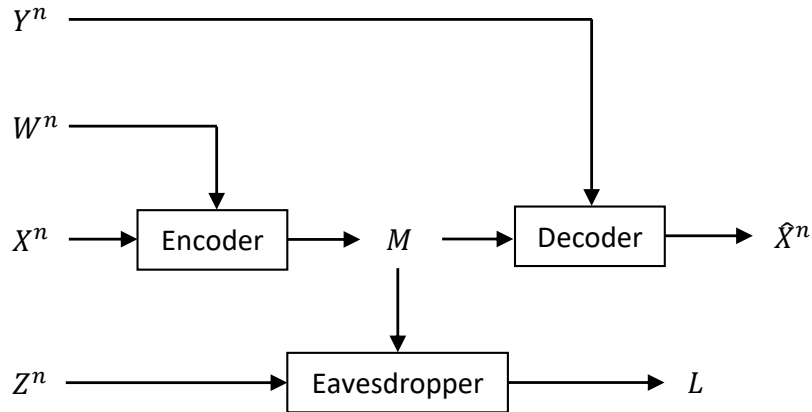

Figure 2: A general framework whose special case (Fig. 1) is considered in this work. The variable L is $H(X^n | Z^n, M)/n$ unless otherwise stated, and characterizes the normalized equivocation at the eavesdropper.

Definition 1 (Source Coding with Rate R and Shared-key Rate R_0). Assume $\{(X_i, Y_i, Z_i)\}_{i=1}^n$ is a block of a tuple of RVs each one defined on the domain $\mathcal{X} \times \mathcal{Y} \times \mathcal{Z}$. Further, let K be a shared-key with rate R_0 , i.e., a RV, independent of the sequence $\{(X_i, Y_i, Z_i)\}_{i=1}^n$, distributed uniformly on $\{1, \dots, 2^{\lfloor nR_0 \rfloor}\}$. A source code with rate R and shared-key with rate R_0 consists of

- a (stochastic) encoder φ that assigns a (possibly random) index with rate R to the source and shared key, i.e.,

$$\varphi: \mathcal{X}^n \times \{1, \dots, 2^{\lfloor nR_0 \rfloor}\} \rightarrow \mathcal{M}, \quad (x^n, k) \mapsto m,$$

where $\mathcal{M} := \{1, \dots, 2^{\lfloor nR \rfloor}\}$,

- a (stochastic) decoder, ψ , that (possibly randomly) reconstructs \hat{X}^n based on the output of the encoder, the key, and the SI at the decoder, i.e.,

$$\psi: \mathcal{M} \times \{1, \dots, 2^{\lfloor nR_0 \rfloor}\} \times \mathcal{Y}^n \rightarrow \hat{\mathcal{X}}^n, \quad (m, k, y^n) \mapsto \hat{x}^n,$$

where $\hat{\mathcal{X}}$ denotes the reconstruction domain.

Next, we define the achievability region.

Definition 2 (Achievable (R, R_0, D, Δ)). Assume that $\{(X_i, Y_i, Z_i)\}_{i=1}^\infty$ is a sequence of RVs, each with support $\mathcal{X} \times \mathcal{Y} \times \mathcal{Z}$. A tuple (R, R_0, D, Δ) is achievable with average normalized distortion level less than D and equivocation greater than Δ , if there exists a sequence of source codes with rate R , shared-key rate R_0 , and output support $\hat{\mathcal{X}}$, such that

$$\limsup_{n \rightarrow \infty} \mathbb{E} \left[d(X^n, \hat{X}^n) \right] \leq D, \tag{1}$$

$$\liminf_{n \rightarrow \infty} \frac{1}{n} H(X^n | M, Z^n) \geq \Delta, \quad \forall i \in \{1, 2, \dots, k\}, \tag{2}$$

where for the given distortion function $d: \mathcal{X} \times \hat{\mathcal{X}} \rightarrow [0, \infty)$, we have

$$d(X^n, \hat{X}^n) := \frac{1}{n} \sum_{i=1}^n d(X_i, \hat{X}_i).$$

3 Main Results

The following theorem identifies the whole achievable region of (R, R_0, D, Δ) .

Theorem 1. Consider the setup of Fig. 1. Assume $p(x, y, z)$ is the PMF of the i.i.d. sequence with finite support $\mathcal{X} \times \mathcal{Y} \times \mathcal{Z}$. Then, (R, R_0, D, Δ) is achievable in the sense of Definition 2, if and only if

$$R \geq I(X; V | Y), \tag{3}$$

$$\Delta \leq \min\{I(Y; V | U) - I(Z; V | U) + H(X | Z, V) + R_0, H(X | Z, U)\}, \tag{4}$$

$$D \geq \mathbb{E} \left[d(X, \hat{X}) \right], \quad (5)$$

for some auxiliary RVs (U, V) with conditional PMF $p(v|x)p(u|v)$ over $\mathcal{U} \times \mathcal{V}$ and function $\hat{x}(y, v)$. Further, it is sufficient to have $|\mathcal{U}| \leq |\mathcal{X}| + 4$ and $|\mathcal{V}| \leq (|\mathcal{X}| + 3)(|\mathcal{X}| + 4)$.

Proof: See the Appendix A. ■

4 Special Cases

This section finds the achievable region for some special cases and recovers known results in the literature.

Corollary 1 (Lossless reconstruction). *Assume that the distortion function is*

$$d(x, \hat{x}) = \begin{cases} 0 & x = \hat{x}, \\ 1 & x \neq \hat{x}. \end{cases}$$

The achievable tuples $(R, R_0, \Delta, 0)$ is

$$R \geq H(X | Y), \quad (6)$$

$$\Delta \leq \min \{ I(X; Y | U) - I(X; Z | U) + R_0, \\ H(X | Z, U) \}, \quad (7)$$

for some conditional PMF $p(u|x)$.

Proof: The proof of the achievability follows from Theorem 1 by selecting $V = X$ and $\hat{x}(y, v) = v = x$; as a result, $D := \mathbb{E} \left[d(X, \hat{X}) \right] = \Pr\{X \neq \hat{X}\} = 0$.

For the proof of the converse, from $D = 0$, we obtain $X = \hat{X}$; as a result, $H(X | Y, V) = H(\hat{X} | Y, V) = 0$, where it follows from the fact that \hat{X} is a function of (Y, V) . Hence, (6) follows from (3) and (7) follows from (4) utilizing (11) in Lemma 1. ■

The following corollary shows the same result as [8, Theorem 3].

Corollary 2 ($R_0 = 0$). *If there is no shared-key ($R_0 = 0$), the achievable region is the same as Theorem 1, with substitution of (4) with*

$$\Delta \leq I(Y; V | U) - I(Z; V | U) + H(X | Z, V).$$

Proof: From (12) in Lemma 1, the right-hand side of (4), for $R_0 = 0$ is $H(X | Z, U) - I(X; V | Y, U)$, which yields the result due to (11) in Lemma 1. ■

Corollary 3 ($Y = \emptyset$). *If $Y = \emptyset$, the achievable region of tuple (R, R_0, D, Δ) , \mathcal{R}^* , is*

$$R \geq I(X; \hat{X}, U), \quad (8)$$

$$\Delta \leq \min \{ R_0 - I(Z; \hat{X} | U) + H(X | Z, \hat{X}, U) \},$$

$$H(X | Z, U)\}, \quad (9)$$

$$D \geq \mathbb{E} \left[d(X, \hat{X}) \right]. \quad (10)$$

for some conditional PMF $p(\hat{x}, u|v)$ over $\hat{\mathcal{X}} \times \mathcal{U}$.

Proof: The proof of the achievability follows from Theorem 1 by selecting $V = (\hat{X}, U)$ and removing terms having Y .

For the proof of the converse, from $Y = \emptyset$, we obtain \hat{X} is a function of V ; as a result, $H(\hat{X} | V) = 0$. Hence, (6) follows from (3) utilizing the fact that

$$I(X; V) \stackrel{(a)}{=} I(X; \hat{X}, V, U) \geq I(X; \hat{X}, U),$$

where (a) follows from the Markov chain $(\hat{X}, U) \rightarrow V \rightarrow (X, Z)$. Similarly, (7) follows from (4), by selecting $Y = \emptyset$ and utilizing

$$\begin{aligned} I(Z; V | U) &\stackrel{(a)}{=} I(Z; V, \hat{X} | U) \geq I(Z; \hat{X} | U), \\ H(X | Z, V) &\stackrel{(b)}{=} H(X | Z, V, \hat{X}, U) \leq H(X | Z, \hat{X}, U), \end{aligned}$$

where (a) and (b) follow from the Markov chain $(\hat{X}, U) \rightarrow V \rightarrow (X, Z)$. ■

Remark 1. For \mathcal{R}^* , defined in Corollary 3, we have

$$\mathcal{R}_{\text{in}} \subseteq \mathcal{R}^* \subseteq \mathcal{R}_{\text{out}},$$

where \mathcal{R}_{in} and \mathcal{R}_{out} are defined in [9, Propositions 1 and 2] for K' instead of Y where $K' \perp\!\!\!\perp (X, Z)$ and $H(K') = R_0$.

Proof: See Appendix ???. ■

Lemma 1. For RVs U, V, X, Y, Z with Markov chain $U \rightarrow V \rightarrow X \rightarrow (Y, Z)$, we have the following equalities:

$$\begin{aligned} I(Y; V | U) - I(Z; V | U) + H(X | Z, V) \\ = H(X | Y, V) + I(X; Y | U) - I(X; Z | U) \end{aligned} \quad (11)$$

$$= H(X | Z, U) - I(X; V | Y, U) \quad (12)$$

$$= H(X | Z) - I(X; V | Y) + I(Z; U) - I(Y; U). \quad (13)$$

Proof: See the Appendix B. ■

5 Conclusions

In this paper, we identified the achievable rate-distortion-equivocation region with side-information only available at the decoder, and a secure shared-key exists between the sender

and receiver. Further, the eavesdropper has access to the description of the source made by the encoder and SI correlated to the source and SI at the decoder. The key is employed as a one-time pad, first protecting V^n and then U^n if key-rate is still available. Interestingly, at the beginning of protecting U^n , the equivocation does not improve since the eavesdropper has SI which is better for the decoding of U^n . This problem serves as an intermediate step towards the more general problem when all parties in the system have different versions of SI, where we expect that a kind of key-extraction will be employed.

References

- [1] C. E. Shannon, “Coding theorems for a discrete source with a fidelity criterion,” *IRE Nat. Conv. Rec.*, vol. 4, no. 1, pp. 325–350, 1959.
- [2] T. Berger, *Rate Distortion Theory: A Mathematical Basis for Data Compression*. Englewood Cliffs, NJ: Prentice-Hall, 1971.
- [3] C. E. Shannon, “Communication theory of secrecy systems,” *Bell Sys. Tech. J.*, vol. 28, no. 4, pp. 656–715, 1949.
- [4] A. D. Wyner, “The wire-tap channel,” *Bell Sys. Tech. J.*, vol. 54, no. 8, pp. 1355–1387, 1975.
- [5] H. Yamamoto, “Rate-distortion theory for the Shannon cipher system,” *IEEE Transactions on Information Theory*, vol. 43, no. 3, pp. 827–835, 1997.
- [6] V. Prabhakaran and K. Ramchandran, “On secure distributed source coding,” in *2007 IEEE Information Theory Workshop*, 2007, pp. 442–447.
- [7] D. Gunduz, E. Erkip, and H. V. Poor, “Secure lossless compression with side information,” in *2008 IEEE Information Theory Workshop*, 2008, pp. 169–173.
- [8] J. Villard and P. Piantanida, “Secure multiterminal source coding with side information at the eavesdropper,” *IEEE Transactions on Information Theory*, vol. 59, no. 6, pp. 3668–3692, 2013.
- [9] Y.-K. Chia and K. Kittichokechai, “On secure source coding with side information at the encoder,” in *2013 IEEE International Symposium on Information Theory*, 2013, pp. 2204–2208.
- [10] Y. Kaspi and N. Merhav, “Zero-delay and causal secure source coding,” *IEEE Transactions on Information Theory*, vol. 61, no. 11, pp. 6238–6250, 2015.
- [11] D. Neuhoff and R. Gilbert, “Causal source codes,” *IEEE Transactions on Information Theory*, vol. 28, no. 5, pp. 701–713, 1982.

- [12] H. Ghourchian, P. A. Stavrou, T. J. Oechtering, and M. Skoglund, “Secure block source coding with sequential encoding,” *IEEE Journal on Selected Areas in Information Theory*, vol. 2, no. 1, pp. 32–48, 2021.
- [13] E. C. Song, P. Cuff, and H. V. Poor, “A rate-distortion based secrecy system with side information at the decoders,” in *2014 52nd Annual Allerton Conference on Communication, Control, and Computing (Allerton)*, 2014, pp. 755–762.
- [14] C. Schieler and P. Cuff, “Rate-distortion theory for secrecy systems,” *IEEE Transactions on Information Theory*, vol. 60, no. 12, pp. 7584–7605, 2014.
- [15] K. Kittichokechai, T. J. Oechtering, and M. Skoglund, “Lossy source coding with reconstruction privacy,” in *2014 IEEE International Symposium on Information Theory*, 2014, pp. 386–390.
- [16] R. Tandon, L. Sankar, and H. V. Poor, “Discriminatory lossy source coding: Side information privacy,” *IEEE Transactions on Information Theory*, vol. 59, no. 9, pp. 5665–5677, 2013.
- [17] R. Balmahoon and L. Cheng, “Information leakage of heterogeneous encoded correlated sequences over an eavesdropped channel,” in *2015 IEEE International Symposium on Information Theory (ISIT)*, 2015, pp. 2949–2953.
- [18] A. El Gamal and Y.-H. Kim, *Network Information Theory*. Cambridge University Press, 2011.
- [19] F. Naghibi, S. Salimi, and M. Skoglund, “The CEO problem with secrecy constraints,” *IEEE Transactions on Information Forensics and Security*, vol. 10, no. 6, pp. 1234–1249, 2015.
- [20] K. Kittichokechai, Y.-K. Chia, T. J. Oechtering, M. Skoglund, and T. Weissman, “Secure source coding with a public helper,” *IEEE Transactions on Information Theory*, vol. 62, no. 7, pp. 3930–3949, 2016.
- [21] S. I. Bross, “Secure cooperative source-coding with side information at the eavesdropper,” *IEEE Transactions on Information Theory*, vol. 62, no. 8, pp. 4544–4558, 2016.
- [22] M. Benammar and A. Zaidi, “On lossy source coding with equivocation constraints,” in *2016 IEEE Information Theory Workshop (ITW)*, 2016, pp. 369–373.
- [23] J. Lu, Y. Xu, P. Zhang, and Q. Wang, “On secure one-helper source coding with action-dependent side information,” *IEEE Transactions on Information Theory*, vol. 67, no. 1, pp. 95–110, 2021.
- [24] M. H. Yassaee, M. R. Aref, and A. Gohari, “Achievability proof via output statistics of random binning,” *IEEE Transactions on Information Theory*, vol. 60, no. 11, pp. 6760–6786, 2014.

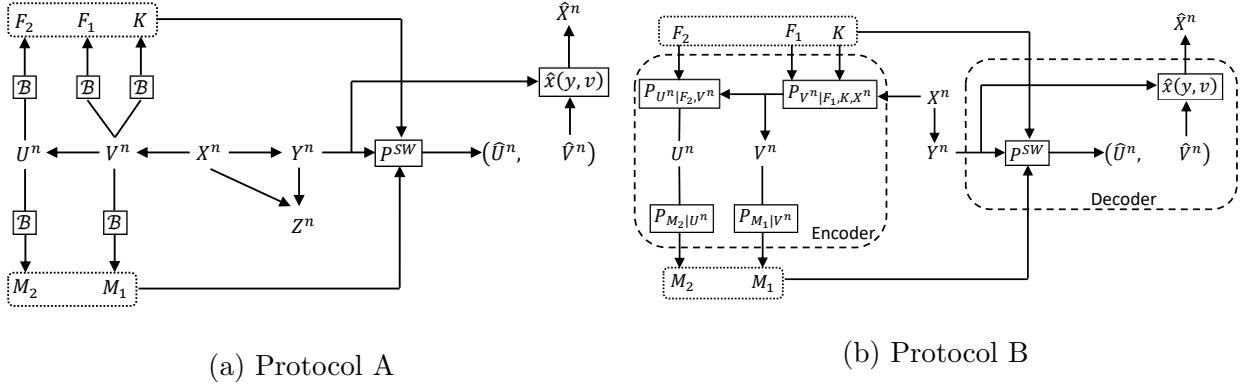

Figure 3: Protocols A and B in the achievability proof of Theorem 1. It is proved that if some constraints are satisfied, the joint probability of the RVs in both protocols become equal with high probability. Hence, the encoder and decoder can be defined from the joint probabilities of the first protocol.

[25] T. M. Cover and J. A. Thomas, *Elements of Information Theory*, 2nd ed. New York: John Wiley & Sons, 2006.

Appendices

A Proof of Theorem 1

The derivation of the proof consists of two parts, the achievability and the converse. In the achievability part, we show that if a tuple (R, R_0, D, Δ) satisfies (3), (4), and (5), then it is achievable in the sense of Definition 2. In the converse part, we show that if a tuple (R, R_0, D, Δ) is achievable in the sense of Definition 2, then it satisfies (3), (4), and (5).

A.1 Achievability

Assume that the distribution $(X, Y, Z, \hat{X}, U, V) \sim p(x, y, z) p(\hat{x}|y, v) p(v|x) p(u|v)$ is given such that it satisfies (3), (4), and (5). To show that (1) and (2) are correct, we use the method proposed in [24].

Step 1: Introducing Protocols A and B.

We define two protocols each of which defines a distribution on the RVs.

Protocol A (well-behaved distribution): Let $(X^n, Y^n, Z^n, U^n, V^n)$ be i.i.d. with PMF $p(x, y, z) p(v|x) p(u|v)$. As illustrated in Fig. 3a, we do the following random binnings (all the random binnings are jointly independent and uniformly distributed over their domain): $M_1 \in [2^{nR_1}]$, $F_1 \in [2^{n\tilde{R}_1}]$, and $K \in [2^{nR_0}]$ are the binnings of V^n ; and $M_2 \in [2^{nR_2}]$ and $F_2 \in [2^{n\tilde{R}_2}]$ are the binnings of U^n .

To obtain (\hat{U}^n, \hat{V}^n) , we utilize the Slepian-Wolf decoder [24, Lemma 1]

$(y^n, m_1, m_2, f_1, f_2, k) \mapsto (\hat{u}^n, \hat{v}^n)$ with induced distributions $P(\hat{u}^n, \hat{v}^n | y^n, m_1, m_2, f_1, f_2, k)$. Finally, to obtain \hat{X}^n , we have $\hat{X}_i = \hat{x}(Y_i, \hat{V}_i)$ for $i = 1, \dots, n$. Hence, the distribution is

$$\begin{aligned}
& P_A(x^n, y^n, z^n, u^n, v^n, \hat{u}^n, \hat{v}^n, \hat{x}^n, m_1, m_2, f_1, f_2, k) \\
&= p(x^n, y^n, z^n) p(v^n | x^n) p(u^n | v^n) \\
&\quad \times P(f_1 | v^n) P(m_1 | v^n) P(k | v^n) P(f_2 | u^n) P(m_2 | u^n) \\
&\quad \times P^{SW}(\hat{u}^n, \hat{v}^n | y^n, m_1, m_2, f_1, f_2, k) p(\hat{x}^n | y^n, \hat{v}^n) \\
&= p(x^n, y^n, z^n) P(f_1, k | x^n) P(v^n | x^n, f_1, k) P(m_1 | v^n) \\
&\quad \times P(f_2 | v^n) P(u^n | v^n, f_2) P(m_2 | u^n) \\
&\quad \times P^{SW}(\hat{u}^n, \hat{v}^n | y^n, m_1, m_2, f_1, f_2, k) p(\hat{x}^n | y^n, \hat{v}^n), \tag{14}
\end{aligned}$$

where

$$p(\hat{x}^n | y^n, \hat{v}^n) = \prod_{i=1}^n \mathbb{I}\{x_i = \hat{x}(y_i, \hat{v}_i)\}.$$

Protocol B (practical distribution): This protocol is similar to our problem statement. We propose an encoder and a decoder for our problem, based on the induced distributions in Protocol A. (X^n, Y^n, Z^n) are generated i.i.d. according to the distribution $p(x, y, z)$. We assume that $F_1 \sim \text{Unif}[2^{n\tilde{R}_1}]$, $F_2 \sim \text{Unif}[2^{n\tilde{R}_2}]$, $K \sim \text{Unif}[2^{nR_0}]$, and (F_1, F_2, K) are jointly independent. Further, the encoder, the decoder, and the eavesdropper have access to F_1 and F_2 , while K is only accessible by the encoder and the decoder.

Encoder: The encoder, first, generates (U^n, V^n) from (X^n, F_1, F_2, K) via the distribution $P(v^n | x^n, f_1, k) P(u^n | v^n, f_2)$ introduced in Protocol A. Then, the encoder sends (M_1, M_2) according to the distribution $P(m_1 | v^n) P(m_2 | u^n)$ introduced in Protocol A.

Decoder: The decoder finds (\hat{U}^n, \hat{V}^n) from $(Y^n, M_1, M_2, F_1, F_2, K)$ using the Slepian-Wolf decoder $P^{SW}(\hat{u}^n, \hat{v}^n | y^n, m_1, m_2, f_1, f_2, k)$. Finally, \hat{X}^n is generated similar to Protocol A, as the $\hat{X}_i = \hat{x}(Y_i, \hat{V}_i)$ for $i = 1, \dots, n$.

Hence, the distribution is

$$\begin{aligned}
& P_B(x^n, y^n, z^n, u^n, v^n, \hat{u}^n, \hat{v}^n, \hat{x}^n, m_1, m_2, f_1, f_2, k) \\
&= p(x^n, y^n, z^n) 2^{-n\tilde{R}_1} 2^{-nR_0} P(v^n | x^n, f_1, k) P(m_1 | v^n) \\
&\quad \times 2^{-n\tilde{R}_2} P(u^n | f_2, v^n) P(m_2 | u^n) \\
&\quad \times P^{SW}(\hat{u}^n, \hat{v}^n | y^n, m_1, m_2, f_1, f_2, k) p(\hat{x}^n | y^n, \hat{v}^n). \tag{15}
\end{aligned}$$

Step 2: Making P_A and P_B identical, and the Slepian-Wolf decoder succeed, asymptotically with high probability in norm 1 distance.

We can write the norm 1 distance as following:

$$\begin{aligned}
\|P_A - P_B\|_1 &= \| [P_A(x^n, y^n, z^n, f_1, f_2, k) - P_B(x^n, y^n, z^n, f_1, f_2, k)] \\
&\quad \times P(u^n, v^n, m_1, m_2, \hat{u}^n, \hat{v}^n | x^n, y^n, z^n, f_1, f_2, k) \|_1 \\
&\stackrel{(a)}{=} \| P_A(x^n, y^n, z^n, f_1, f_2, k) - P_B(x^n, y^n, z^n, f_1, f_2, k) \|_1, \tag{16}
\end{aligned}$$

where $P(u^n, v^n, m_1, m_2, \hat{u}^n, \hat{v}^n | x^n, y^n, z^n, f_1, f_2, k)$ is the part which is equal in both P_A and P_B ; and (a) follows from [24, Lemma 3.1]. Hence, it is sufficient to have

$$\lim_{n \rightarrow \infty} \mathbb{E} \left[\|P_A(x^n, y^n, z^n, f_1, f_2, k) - p(x^n, y^n, z^n) 2^{-nR_0} 2^{-n\tilde{R}_1} 2^{-n\tilde{R}_2}\|_1 \right] = 0. \quad (17)$$

In order to obtain (17), from [24, Theorem 1] (for $X_i \leftarrow V$, for $i = 1, 2$, $X_i \leftarrow U$, for $i = 3$, and $Z \leftarrow (X, Y, Z)$), it is sufficient to have

$$R_0 + \tilde{R}_1 < H(V | X, Y, Z) = H(V | X), \quad (18)$$

$$\tilde{R}_2 < H(U | X, Y, Z) = H(U | X), \quad (19)$$

$$R_0 + \tilde{R}_1 + \tilde{R}_2 < H(U, V | X, Y, Z) = H(U, V | X), \quad (20)$$

where the equalities follow from the Markov chain $(U, V) \rightarrow X \rightarrow (Y, Z)$ in Protocol A.

Now, we need to find the conditions making the Slepian-Wolf decoder work properly, i.e.,

$$\lim_{n \rightarrow \infty} \mathbb{E} [\|P_A(y^n, u^n, v^n, \hat{u}^n, \hat{v}^n) - \mathbb{I}\{u^n = \hat{u}^n, v^n = \hat{v}^n\} p(y^n, u^n, v^n)\|_1] = 0. \quad (21)$$

From [24, Lemma 1] (for $X_i \leftarrow V$, for $i = 1, 2, 3$, $X_i \leftarrow U$, for $i = 4, 5$, and $Z \leftarrow Y$), (21) follows if

$$R_0 + R_1 + \tilde{R}_1 > H(V | Y, U), \quad (22)$$

$$R_2 + \tilde{R}_2 > H(U | Y, V) = H(U | V), \quad (23)$$

$$R_0 + R_1 + R_2 + \tilde{R}_1 + \tilde{R}_2 > H(U, V | Y), \quad (24)$$

where the equality follows from the Markov chain $U \rightarrow V \rightarrow Y$ in Protocol A.

Next, we try to make the coding secure. As we show later, it is sufficient to have

$$\lim_{n \rightarrow \infty} \mathbb{E} \left[\|P_A(x^n, z^n, u^n, m_1, f_1) - p(x^n, z^n, u^n) 2^{-nR_1} 2^{-n\tilde{R}_1}\|_1 \right] = 0. \quad (25)$$

From [24, Theorem 1] (for $X_i \leftarrow V$, for $i = 1, 2$, and $Z \leftarrow (X, Z, U)$), (25) it is concluded if

$$R_1 + \tilde{R}_1 < H(V | X, Z, U) = H(V | X, U), \quad (26)$$

where the equality follows from the Markov chain $(U, V) \rightarrow X \rightarrow Z$, in Protocol A. Later, utilizing Fourier-Motzkin elimination [18, Appendix D], we obtain that (18), (19), (20), (22), (23), (24), and (26) are equivalent to

$$\begin{cases} R_0 > I(X; V | Y, U), \\ R > I(X; V | Y). \end{cases} \quad (27)$$

Therefore, from (16), (17), (21), and (25), we obtain that, for all $\epsilon > 0$, if (27) is satisfied, there exist binning functions, b , such that, for large enough n ,

$$\|p_B(\cdot | b) - p_C(\cdot | b)\|_1 \leq \epsilon, \quad (28)$$

$$\|p_B(x^n, z^n, u^n, m_1, f_1 | b) - p(x^n, z^n, u^n) 2^{-nR_1} 2^{-n\tilde{R}_1}\|_1 \leq \epsilon, \quad (29)$$

where

$$\begin{aligned}
& p_C(x^n, y^n, z^n, u^n, v^n, \hat{u}^n, \hat{v}^n, \hat{x}^n, m_1, m_2, f_1, f_2, k | b) \\
& := \prod_{i=1}^n p(x_i, y_i, z_i) p(v_i | x_i) p(u_i | v_i) \\
& \quad \times p(f_1 | v^n, b) p(m_1 | v^n, b) p(k | v^n, b) \\
& \quad \times p(f_2 | u^n, b) p(m_2 | u^n, b) \\
& \quad \times \mathbb{I}\{u^n = \hat{u}^n, v^n = \hat{v}^n\} \prod_{i=1}^n p(\hat{x}_i | y_i, \hat{v}_i). \tag{30}
\end{aligned}$$

Step 3: Removing the common randomness F_1, F_2 .

To be able to provide feasible encoder and decoder, we cannot use distribution P_B because they are a function of common randomness (F_1, F_2) which does not exist in reality. Hence, it suffices to find an instance (f_1, f_2) of (F_1, F_2) such that the distribution $p(x^n, y^n, z^n)$ is not changed, and (1) and (2) are satisfied. Then, $p(m_1, m_2 | x^n, f_1, f_2, k, b)$ and $p^{SW}(\hat{x}^n | y^n, f_1, f_2, k, b)$ are the final encoder and decoder.

We consider the following cases:

- $R_0 > I(X; V | Y, U)$: For the distortion, from (30), we have that for any small $\zeta > 0$

$$\begin{aligned}
& \mathbb{E}_{p_C} [\mathbb{E}_{p_C} [\mathbb{I}\{d(X^n, \hat{X}^n) > D + \zeta\} | F_1, F_2, b]] \\
& = \mathbb{E}_{p_C} [\mathbb{I}\{d(X^n, \hat{X}^n) > D + \zeta\} | b] \\
& = \Pr_{p_C} \{d(X^n, \hat{X}^n) > D + \zeta\} \\
& \stackrel{(a)}{\leq} \frac{d_{\max}^2}{n \left(D + \zeta - \mathbb{E} [d(X, \hat{X})] \right)^2},
\end{aligned}$$

where \mathbb{E}_{p_C} denotes the expectation with distribution p_C , $d_{\max} := \max_{x, \hat{x}} d(x, \hat{x})$, and (a) follows from (5) and the Chebyshev's bound. Hence, from [24, Lemma 5] and (28), we have

$$\begin{aligned}
& \mathbb{E}_{p_B} [\mathbb{E}_{p_B} [\mathbb{I}\{d(X^n, \hat{X}^n) > D + \zeta\} | F_1, F_2, b]] \\
& = \Pr_{p_B} \{d(X^n, \hat{X}^n) > D + \zeta\} \\
& \leq \epsilon d_{\max} + \frac{d_{\max}^2}{n \left(D + \zeta - \mathbb{E} [d(X, \hat{X})] \right)^2}. \tag{31}
\end{aligned}$$

For the equivocation, for the distribution p_B , we have

$$\begin{aligned}
H(X^n | Z^n, M_1, M_2, F_1, F_2, b) & \stackrel{(a)}{\geq} H(X^n | Z^n, U^n, M_1, F_1, b) \\
& \stackrel{(b)}{=} H(X^n | Z^n, U^n, b) - n\delta \\
& \stackrel{(c)}{=} H(X^n | Z^n, U^n) - n\delta, \tag{32}
\end{aligned}$$

where (a) follows due to the fact that, based on (15), (M_2, F_2) is a function of (U^n, b) ; (b) follows from (29) and [25, Theorem 17.3.3] for some $\delta \leq 2c\epsilon - 2\epsilon \log \epsilon$ for $c = \log(|\mathcal{X}||\mathcal{Z}||\mathcal{U}|) + R$, which $\delta \rightarrow 0$ as $\epsilon \rightarrow 0$; and (c) follows from (29). Thus, there exist f_1 and f_2 such that (1) and (2) are satisfied.

- $R_0 \leq I(X; V | Y, U)$: We assume that there is a shared-key \bar{K} with rate $\bar{R}_0 = I(X; V | Y, U) + \zeta$, for some small $\zeta > 0$. Then, \bar{K} is split into two independent parts K and K' with rates R_0 and $\bar{R}_0 - R_0$, respectively. We claim that the problem is equivalent to the case when \bar{K} is the shared-key while K' is known to all the encoder, decoder, and eavesdropper. It is sufficient to show that there exists a realization (f_1, f_2, k') that satisfies (1) and (2).

For the distortion, we exactly do as the former case with (F_1, F_2, K') instead of (F_1, F_2) . For the equivocation, if we use encoding with rate \bar{R}_0 instead of R_0 , according to the previous case, we have

$$H(X^n | Z^n, M_1, M_2, F_1, F_2, b) \geq nH(X | Z, U) - n\delta.$$

Further, we obtain

$$H(X^n | Z^n, M_1, M_2, F_1, F_2, K', b) \leq H(X^n | Z^n, M_1, M_2, F_1, F_2, b) + n\bar{R}_0 - nR_0.$$

Hence, we have

$$\begin{aligned} & H(X^n | Z^n, M_1, M_2, F_1, F_2, b) \\ & \geq n[H(X | Z, U) - I(X; V | Y, U) + R_0 - \delta] \\ & = n[I(Y; V | U) - I(Z; V | U) + H(X | Z, V) + R_0 - \delta], \end{aligned} \quad (33)$$

where the equality follows because

$$\begin{aligned} & H(X | Z, U) - I(X; V | Y, U) - H(X | Z, V) \\ & = I(X; V | Z, U) - I(X; V | Y, U) \\ & = I(X; V | U) - I(Z; V | U) - I(X; V | U) + I(Y; V | U) \\ & = I(Y; V | U) - I(Z; V | U). \end{aligned}$$

Therefore, there exists (f_1, f_2, k') such that (1) and (2) are satisfied.

Thus, the proof of the theorem is complete. We only need to prove (27).

Proof of (27): First, we remove \tilde{R}_2 . Hence, from (19), (20), (23), and (24), we have

$$\begin{aligned} & \max\{H(U | V) - R_2, H(U, V | Y) - R_0 - R_1 - R_2 - \tilde{R}_1\} \\ & < \tilde{R}_2 < \min\{H(U | X), H(U, V | X) - R_0 - \tilde{R}_1\}. \end{aligned}$$

Hence, instead of (19), (20), (23), and (24), we have

$$R_2 > H(U | V) - H(U | X) = -I(U; V | X), \quad (34)$$

$$R_0 + \tilde{R}_1 - R_2 < H(U, V | X) - H(U | V) = H(V | X), \quad (35)$$

$$R_0 + R_1 + R_2 + \tilde{R}_1 > H(U, V | Y) - H(U | X) = H(V | Y) - I(U; V | X), \quad (36)$$

$$R_1 + R_2 > H(U, V | Y) - H(U, V | X) = I(X; U, V | Y) = I(X; V | Y), \quad (37)$$

where all the equalities follows from the Markov chain $U \rightarrow V \rightarrow X \rightarrow (Y, Z)$.

Next, we remove \tilde{R}_1 . From (18), (22), (26), (35), and (36), we obtain

$$\begin{aligned} & \max\{H(V | Y, U) - R_0 - R_1, H(V | Y) - I(U; V | X) - R_0 - R_1 - R_2\} \\ & < \tilde{R}_1 < \min\{H(V | X) - R_0, H(V | X, U) - R_1, H(V | X) - R_0 + R_2\}. \end{aligned}$$

Therefore, the following inequalities are substituted with (18), (22), (26), (35), and (36)

$$R_1 > H(V | Y, U) - H(V | X) = I(X; V | Y, U) - I(U; V | X), \quad (38)$$

$$R_0 > H(V | Y, U) - H(V | X, U) = I(X; V | Y, U), \quad (39)$$

$$R_1 + R_2 > H(V | Y, U) - H(V | X), \quad (40)$$

$$R_1 + R_2 > H(V | Y) - I(U; V | X) - H(V | X) = I(X; V | Y) - I(U; V | X), \quad (41)$$

$$R_0 + R_2 > H(V | Y) - I(U; V | X) - H(V | X, U) = I(X; V | Y), \quad (42)$$

$$R_1 + 2R_2 > H(V | Y) - I(U; V | X) - H(V | X) = I(X; V | Y) - I(U; V | X), \quad (43)$$

where all the equalities follows from the Markov chain $U \rightarrow V \rightarrow X \rightarrow (Y, Z)$. Thus, all the inequalities are (34), (37), (38), (39), (40), (41), (42), and (43), where (34), (40), (41), and (43) are redundant because of $R_2 \geq 0$, (38), (37), and (41), respectively. Finally, by selecting $R_1 = R - R_2$, from (37), (38), and (42) we obtain,

$$R > I(X; V | Y), \quad (44)$$

$$R - R_2 > I(X; V | Y, U) - I(U; V | X), \quad (45)$$

$$R_0 + R_2 > I(X; V | Y). \quad (46)$$

Next, we remove R_2 . Hence, instead of (45) and (46), we have

$$\begin{aligned} I(X; V | Y) - R_0 &< R_2 < R - I(X; V | Y, U) + I(U; V | X) \\ &\Rightarrow R + R_0 > I(X; V | Y) + I(X; V | Y, U) - I(U; V | X), \end{aligned}$$

which is redundant due to (39) and (44). Thus, (27) follows.

A.2 Converse

To prove the converse part, we assume that there exists a sequence of source codes with rate R such that (1) and (2) are satisfied, and we will show that we can identify auxillary RVs assignment, with conditional distribution $p(v|x) p(u|v) p(\hat{x}|v, y)$, that satisfies (3), (4), and (5). For $i = 1, \dots, n$, we assign

$$\begin{cases} U_i := (Y_{i+1}^n, Z^{i-1}, M), \\ V_i := (X^{i-1}, Y^{i-1}, Y_{i+1}^n, Z^{i-1}, M, K), \\ Q \sim \text{Unif}\{1, \dots, n\}, \\ V := (V_Q, Q), \\ Q := (U_Q, Q), \end{cases} \quad (47)$$

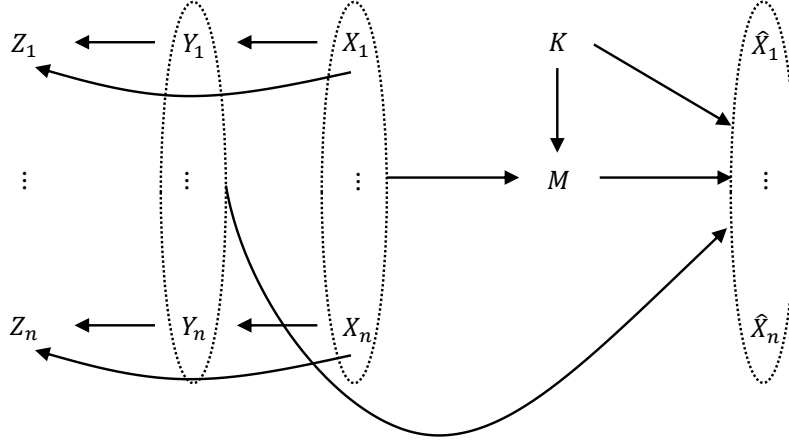

Figure 4: The graphical representation of the problem.

where Q is independent of $(M, K, X^n, Y^n, Z^n, \hat{X}^n)$. It can be seen that we have the Markov chain $U_i \rightarrow V_i \rightarrow X_i \rightarrow (Y_i, Z_i)$, for $i = 1, \dots, n$ (see Fig. 4).

Proof of (3): Because the coding rate is R , the following series of inequalities hold:

$$\begin{aligned}
nR &\geq H(M) \geq H(M | Y^n, Z^{i-1}, K) \geq I(X^n; M | Y^n, Z^{i-1}, K) \\
&= \sum_{i=1}^n I(X_i; M | X^{i-1}, Y^n, Z^{i-1}, K) \\
&\stackrel{(a)}{=} \sum_{i=1}^n I(X_i; X^{i-1}, Y^{i-1}, Y_{i+1}^n, Z^{i-1}, M, K | Y_i) \\
&= \sum_{i=1}^n I(X_i; V_i | Y_i) \\
&\stackrel{(b)}{=} nI(X_Q; V_Q | Y_Q, Q) \\
&\stackrel{(c)}{=} nI(X_Q; V_Q, Q | Y_Q) \\
&\stackrel{(d)}{=} nI(X; V | Y), \tag{48}
\end{aligned}$$

where (a) follows from (X^n, Y^n, Z^n) being i.i.d. and $K \perp\!\!\!\perp (X^n, Y^n, Z^n)$, as a result, $(X_i, Y_i) \perp\!\!\!\perp (X^{i-1}, Y^{i-1}, Y_{i+1}^n, Z^{i-1}, K)$; (b) follows from $Q \perp\!\!\!\perp (X^n, Y^n)$ and Q being uniformly distributed; (c) follows from independency of Q and (X_Q, Y_Q) which is the result of (X^n, Y^n) being i.i.d., $Q \perp\!\!\!\perp (X^n, Y^n)$ and uniformly distributed; and (d) follows from the Markov chain $V \rightarrow (X_Q, Y_Q) \rightarrow Z_Q$ and $(X_Q, Y_Q, Z_Q) \sim p(x, y, z)$, so, we can substitute X_Q, Y_Q , and Z_Q with X, Y , and Z , respectively.

Proof of (4): From (2), we obtain that, for any given small ϵ , if n is large enough, we have

$$\begin{aligned}
n(\Delta - \epsilon) &\leq H(X^n | M, Z^n) = H(X^n | Z^n) - I(X^n; M | Z^n) \\
&\stackrel{(a)}{=} H(X^n | Z^n) - I(X^n; M) + I(Z^n; M)
\end{aligned}$$

$$\begin{aligned}
&\stackrel{(b)}{=} H(X^n | Z^n) \\
&\quad - I(X^n; M | K) + I(X^n; K | M) + I(Z^n; M) \\
&\quad - I(Y^n; M) + I(Y^n; M | K) - I(Y^n; K | M) \\
&= H(X^n | Z^n) \\
&\quad - [I(X^n; M | K) - I(Y^n; M | K)] \\
&\quad + I(Z^n; M) - I(Y^n; M) \\
&\quad + I(X^n; K | M) - I(Y^n; K | M), \tag{49}
\end{aligned}$$

where (a) follows from the Markov chain $M \rightarrow X^n \rightarrow Z^n$; and (b) follows from $X^n \perp\!\!\!\perp K$ and $Y^n \perp\!\!\!\perp K$. Next, we bound each term in (49), as follows:

$$\begin{aligned}
I(X^n; M | K) - I(Y^n; M | K) &\stackrel{(a)}{=} I(X^n; M | Y^n, K) \\
&= \sum_{i=1}^n I(X_i; M | X^{i-1}, Y^n, K) \\
&\stackrel{(b)}{=} \sum_{i=1}^n I(X_i; M | X^{i-1}, Y^n, Z^{i-1}, K) \\
&\stackrel{(c)}{=} \sum_{i=1}^n I(X_i; X^{i-1}, Y^{i-1}, Y_{i+1}^n, Z^{i-1}, M, K | Y_i) \\
&= \sum_{i=1}^n I(X_i; V_i | Y_i), \tag{50}
\end{aligned}$$

where (a) follows from $M \rightarrow (X^n, K) \rightarrow Y^n$; whereas (b) and (c) follow from (X^n, Y^n, Z^n) being i.i.d., and $M \rightarrow (X^n, K) \rightarrow (Y^n, Z^n)$, as a result, $(X_i, Y_{i+1}^n, M) \rightarrow (X^{i-1}, K) \rightarrow (Y^{i-1}, Z^{i-1})$.

For the next term in (49), we have

$$\begin{aligned}
I(Z^n; M) - I(Y^n; M) &= \sum_{i=1}^n I(Z_i; M | Z^{i-1}) - I(Y_i; M | Y_{i+1}^n) \\
&\stackrel{(a)}{=} \sum_{i=1}^n I(Z_i; Y_{i+1}^n, M | Z^{i-1}) - I(Y_i; Z^{i-1}, M | Y_{i+1}^n) \\
&\stackrel{(b)}{=} \sum_{i=1}^n I(Z_i; Y_{i+1}^n, Z^{i-1}, M) - I(Y_i; Y_{i+1}^n, Z^{i-1}, M) \\
&= \sum_{i=1}^n I(Z_i; U_i) - I(Y_i; U_i), \tag{51}
\end{aligned}$$

where (a) follows from Csiszár sum identity [18, p. 25]; and (b) follows from (X^n, Y^n, Z^n) being i.i.d., as a result, $(Y_i, Z_i) \perp\!\!\!\perp (Y_{i+1}^n, Z^{i-1})$, for all $i = 1, \dots, n$.

For the next term in (49), we obtain

$$I(X^n; K | M) - I(Y^n; K | M) \stackrel{(a)}{=} I(X^n; K | Y^n, M) \leq H(K) = nR_0, \tag{52}$$

where (a) follows from $(X^n, Y^n) \perp\!\!\!\perp K$ and the Markov chain $Y^n \rightarrow (X^n, K) \rightarrow M$. Utilizing this result, we further obtain

$$\begin{aligned}
I(X^n; K | M) - I(Y^n; K | M) &= I(X^n; K | Y^n, M) \\
&= \sum_{i=1}^n I(X_i; K | X^{i-1}, Y^n, M) \\
&\stackrel{(a)}{=} \sum_{i=1}^n I(X_i; K | X^{i-1}, Y^n, Z^{i-1}, M) \\
&\leq \sum_{i=1}^n I(X_i; X^{i-1}, Y^{i-1}, K | Y_i, Y_{i+1}^n, Z^{i-1}, M) \\
&= \sum_{i=1}^n I(X_i; V_i | Y_i, U_i), \tag{53}
\end{aligned}$$

where (a) follows from (X^n, Y^n, Z^n) being i.i.d. and $K \rightarrow (X^n, M) \rightarrow (Y^n, Z^n)$, which is obtained from $M \rightarrow (X^n, K) \rightarrow (Y^n, Z^n)$ and $K \perp\!\!\!\perp (X^n, Y^n, Z^n)$, as a result, $(X_i, Y_{i+1}^n, K) \rightarrow (X^{i-1}, M) \rightarrow (Y^{i-1}, Z^{i-1})$ (see Fig. 4 and marginalize over \hat{X}^n).

Therefore, from (49), (50), (51), (52), (53), and the fact that (X^n, Z^n) is i.i.d., we obtain that

$$\begin{aligned}
n(\Delta - \epsilon) &\leq \sum_{i=1}^n H(X_i | Z_i) - I(X_i; V_i | Y_i) \\
&\quad + I(Z_i; U_i) - I(Y_i; U_i) \\
&\quad + \min\{R_0, I(X_i; V_i | Y_i, U_i)\} \\
&= n[H(X | Z) - I(X_Q; V_Q | Y_Q, Q) \\
&\quad + I(Z_Q; U_Q | Q) - I(Y_Q; U_Q | Q) \\
&\quad + \min\{R_0, I(X_Q; V_Q | Y_Q, U_Q, Q)\}] \\
&= n[H(X | Z) - I(X_Q; V_Q, Q | Y_Q) \\
&\quad + I(Z_Q; U_Q, Q) - I(Y_Q; U_Q, Q) \\
&\quad + \min\{R_0, I(X_Q; V_Q, | Y_Q, U_Q, Q)\}] \\
&= n[H(X | Z) - I(X; V | Y) \\
&\quad + I(Z; U) - I(Y; U) \\
&\quad + \min\{R_0, I(X; V | Y, U)\}], \tag{54}
\end{aligned}$$

where the last three steps follow the same arguments of the last three steps of (48). Using (12) and (13) from Lemma 1, (4) follows from (54).

Proof of (5): From (1), we obtain that, for any given small ϵ , if n is large enough, we have

$$D + \epsilon \geq \mathbb{E} \left[d(X^n, \hat{X}^n) \right] = \frac{1}{n} \sum_{i=1}^n \mathbb{E} \left[d(X_i, \hat{X}_i) \right]$$

$$\stackrel{(a)}{=} \mathbb{E} \left[d(X_Q, \hat{X}_Q) \right]$$

$$\stackrel{(b)}{=} \mathbb{E} \left[d(X, \hat{X}) \right],$$

where (a) follows from $Q \perp\!\!\!\perp (X^n, \hat{X}^n)$; for (b) recall the Markov chain $(X^n, Z^n) \rightarrow (Y^n, M, K) \rightarrow \hat{X}^n$, as a result, we have $(X_i, Z_i) \rightarrow (V_i, Y_i) \rightarrow \hat{X}_i$, so, $(X_Q, Z_Q) \rightarrow (V, Y_Q) \rightarrow \hat{X}_Q$; thus, it follows by renaming \hat{X}_Q with \hat{X} and utilizing the fact that $X_Q \sim p(x)$.

To show that it is sufficient for \hat{X} to be a function of (V, Y) , we do the following

$$\begin{aligned} \mathbb{E} \left[d(X, \hat{X}) \right] &= \mathbb{E} \left[\mathbb{E} \left[d(X, \hat{X}) \mid Y, V \right] \right] \\ &\geq \mathbb{E} \left[\min_{\hat{x}} \mathbb{E} \left[d(X, \hat{x}(Y, V)) \mid Y, V \right] \right]. \end{aligned}$$

Hence, the result follows.

A.3 Cardinality bounds

To show the cardinality bounds, we use the method explained in [18, Appendix C]. First, we assume that $p(x|v)$ is fixed. Without loss of generality, we assume that $\mathcal{X} = \{1, \dots, |\mathcal{X}|\}$. Consider the following functions over the set of all PMFs $p(v|u)$ on \mathcal{V} :

$$\begin{cases} p(x|u) & x = 1, \dots, |\mathcal{X}| - 1, \\ H(X \mid Y, V, U = u), \\ I(Y; V \mid U = u), \\ I(Z; V \mid U = u), \\ H(X \mid Z, V, U = u), \\ H(X \mid Z, U = u). \end{cases}$$

Therefore, from the support lemma [18, Appendix C], we obtain that for any $U \sim F(u)$, there exists U' with PMF of cardinality at most $|\mathcal{X}| + 4$ such that the following functions are preserved:

$$\begin{cases} p(x) & x \in \mathcal{X} \\ \Rightarrow p(x, y, z) = p(x)p(y, z|x) & (x, y, z) \in \mathcal{X} \times \mathcal{Y} \times \mathcal{Z}, \\ H(X \mid Y, V, U) = H(X \mid Y, V) \\ \Rightarrow I(X; V \mid Y) = H(X \mid Y) - H(X \mid Y, V), \\ I(Y; V \mid U), \\ I(Z; V \mid U), \\ H(X \mid Z, V, U) = H(X \mid Z, V), \\ H(X \mid Z, U). \end{cases}$$

Let V' denote the corresponding RV after choosing U' . For bounding the cardinality of

V , for each $u' \in \mathcal{U}'$, consider the following functions over the set of all PMFs $p(x|v', x')$:

$$\begin{cases} p(x|u', v') & x = 1, \dots, |\mathcal{X}| - 1, \\ H(X | Y, V' = v', U' = u'), \\ H(Y | V' = v', U' = u'), \\ H(Z | V' = v', U' = u'), \\ H(X | Z, V' = v', U' = u'). \end{cases} \quad (55)$$

Therefore, from the support lemma [18, Appendix C], we obtain that for any $u' \in \mathcal{U}'$ and $V' \sim F(v'|u')$, there exists V'' with PMF of cardinality at most $|\mathcal{X}| + 3$ such that the following functions are preserved:

$$\begin{cases} p(x|u') & x \in \mathcal{X} \\ \Rightarrow p(x, y, z|u') = p(x|u')p(y, z|x) & (x, y, z) \in \mathcal{X} \times \mathcal{Y} \times \mathcal{Z}, \\ H(X | Y, V, U' = u'), \\ H(Y | V', U' = u') \\ \Rightarrow H(Y|U' = u') - H(Y | V', U' = u'), \\ H(Z | V', U' = u') \\ \Rightarrow H(Z | U' = u') - H(Z | V', U' = u'), \\ H(X | Z, V, U' = u'). \end{cases}$$

However, to have the Markov chain $U \rightarrow V \rightarrow X \rightarrow (Y, Z)$, we consider $V''' = (V'', U')$ instead of V'' . In this case, the cardinality of V''' becomes $(|\mathcal{X}| + 4)(|\mathcal{X}| + 3)$. With this change of variable, all the variables in (55) remains unaffected. Thus, the cardinality bound is proved.

B Proof of Lemma 1

Proof of (13):

$$\begin{aligned} & H(X | Z) - I(X; V | Y) + I(Z; U) - I(Y; U) \\ &= H(X | Z, V) + I(X; V | Z) \\ &\quad - I(X; V | Y) + I(Z; U) - I(Y; U) \\ &\stackrel{(a)}{=} H(X | Z, V) + I(X; V) - I(Z; V) \\ &\quad - I(X; V) + I(Y; V) + I(Z; U) - I(Y; U) \\ &\stackrel{(b)}{=} H(X | Z, V) + I(Y; V | U) - I(Z; V | U), \end{aligned}$$

where (a) follows from $V \rightarrow X \rightarrow Z$ and $V \rightarrow X \rightarrow Y$; and (b) follows from $U \rightarrow V \rightarrow Y$ and $U \rightarrow V \rightarrow Z$.

Proof of (12):

$$H(X | Z) - I(X; V | Y)$$

$$\begin{aligned}
& +I(Z;U) - I(Y;U) + I(X;V | Y,U) \\
\stackrel{(a)}{=} & H(X | Z) - I(X;U | Y) + I(Z;U) - I(Y;U) \\
\stackrel{(b)}{=} & H(X | Z) - I(X;U) + I(Z;U) \\
\stackrel{(c)}{=} & H(X | Z) - I(X;U | Z) \\
= & H(X | U, Z),
\end{aligned}$$

where (a) follows from the Markov chain $U \rightarrow V \rightarrow (X, Y)$; (b) follows from the Markov chain $U \rightarrow X \rightarrow Y$; and (c) follows from the Markov chain $U \rightarrow X \rightarrow Z$. Finally, (12) follows from (13).

Proof of (11):

$$\begin{aligned}
& H(X | Z, U) - I(X;V | Y, U) \\
\stackrel{(a)}{=} & H(X | Y, V) + H(X | Z, U) - H(X | Y, U) \\
= & H(X | Y, V) - I(X;Z | U) + I(X;Y | U).
\end{aligned}$$

where (a) follows from the Markov chain $U \rightarrow V \rightarrow (X, Y)$. Finally, (11) follows from (12).