

Quantum Meet-in-the-Middle Attack on 7-round Feistel Construction

Yinsong, Xu · Zhen, Yuan*

Received: date / Accepted: date

Abstract Quantum attacks on Feistel constructions have attracted much more attention from worldwide cryptologists. To reduce the time complexity of quantum attacks on 7-round Feistel construction, we propose a quantum meet-in-the-middle attack based on quantum claw finding algorithm and 5-round distinguisher in Q1 model firstly. Compared with quantum attacks in Q2 model, our attack reduce the time complexity from $O(2^n)$ to $O(2^{7n/8})$. Moreover, our attack belongs to Q1 model, which is more practical than Q2 model. When compared with best classical attacks, our attack not only reduces the time complexity, but also reduces the data and memory complexity by $2^{n/2}$ and $2^{n/4}$ respectively.

Keywords Quantum meet-in-the-middle attack · 7-round Feistel construction · Quantum claw finding algorithm · 5-round distinguisher

1 Introduction

Since the Shor's algorithm [1] was proposed, public key cryptosystems have been broken, such as RSA and ECC. Researchers hope to use new quantum

Y. Xu

School of Cyberspace Security, Beijing University of Posts and Telecommunications, Beijing, 100876, China.

Beijing Electronic Science and Technology Institute, Beijing, 100070, China.

E-mail: mugongxys@foxmail.com

Z. Yuan

*Corresponding Author

School of Cyberspace Security, Beijing University of Posts and Telecommunications, Beijing, 100876, China.

Beijing Electronic Science and Technology Institute, Beijing, 100070, China.

School of Cyberspace Science and Technology, University of Science and Technology of China, Hefei, 230026, China.

E-mail: zyuan@tsinghua.edu.cn

algorithms to break other cryptosystems, especially the symmetric cryptosystems. They use Grover's algorithm [2] to reduce the cost of exhaustive search on a n -bit key from 2^n to $2^{n/2}$ in quantum setting early. But, it is observed that doubling the key length of one block cipher could achieve a similar amount of security against quantum attackers.

Until 2010, Kuwakado *et al.* [3] proposed a quantum 3-round distinguisher of Feistel construction based on the Simon's algorithm [4], which reduces the time complexity of key recovery from $O(2^n)$ to $O(n)$. Then, more and more specific constructions have been evaluated under post-quantum security, e.g. against Even-Mansour cipher [5], CBC-like MACs [6, 7], AEZ [8], AES-COPA [9], FX construction [10], Feistel constructions [11–15], etc. Kaplan [16] divides these quantum attacks into two attack models based on the adversary's ability, Q1 model and Q2 model.

Q1 model: The adversary is allowed to make classical online queries and perform quantum computation offline.

Q2 model: The adversary is allowed to make quantum superposition online queries. That is, oracles allow queries in quantum superposition states and return the results as quantum superposition states.

It can be seen that the adversary is more realistic in Q1 model, and more powerful in Q2 model.

Among these quantum attacks, the quantum attacks on r -round Feistel constructions is a hot topic, which have four ways to reduce complexity. The first one is to use quantum slide attack based on Simon's algorithm in Q2 model [11, 14]. Although it can even reduce time complexity from $O(2^{rn/2})$ to $O(n)$ when $r \leq 4$, it may not necessarily effective because of two many keys needing to be guessed when $r > 4$. The second one is to combine Grover's algorithm and quantum 3-round distinguisher in Q2 model, whose time complexity is $O(2^{0.25nr-0.75n})$ [12, 13]. The third one is to propose new quantum distinguishers for 3-round Feistel scheme based on Bernstein–Vazirani algorithm [17]. This work provides an novel attack method, but its complexity is $O(n^2)$, which is higher than Kuwakado *et al.*'s work [3]. The last one is to propose a quantum meet-in-the-middle attack based on quantum claw finding algorithm and 5-round distinguisher in Q1 model [15]. However, Hosoyamada *et al.*'s work [15] can only be applied on 6-round Feistel construction, not on 7-round or more. And its proposed quantum claw finding algorithm needs $O(2^p)(p \leq n/2)$ independent processors to run Grover's algorithm parallelly. In other words, it does not take advantage of the quantum claw finding algorithm.

Inspired from Hosoyamada *et al.*'s work [15], and to reduce the time complexity of quantum attacks on 7-round Feistel construction, we propose a new quantum meet-in-the-middle attack in Q1 model. Although our attack and Hosoyamada's attack both use the quantum claw finding algorithm to solve the claw finding problem caused by 5-round distinguisher, our proposed quantum claw finding algorithm is based on amplitude amplification, which does not need multiple independent processors to run parallelly. Analysis shows that the time complexity of our attack only needs $O(2^{7n/8})$. Although our

attack needs $O(2^{5n/8})$ qubits, which is higher than quantum attacks in Q2 model, our attack is more practical in Q1 model. And compared with classic attacks, our attack also reduces the data and memory complexity by $2^{n/2}$ and $2^{n/4}$ respectively.

This paper is organized as follows. Sect. 2 provides a brief description of amplitude amplification, quantum claw finding algorithm and 5-round distinguisher. And our quantum meet-in-the-middle attack on 7-round Feistel construction is shown in Sects. 3. Then, the comparison with classical and other quantum attacks is analyzed in Sect. 4, followed by a conclusion in Sect. 5.

2 Preliminaries

In this section, we would briefly introduce amplitude amplification, quantum claw finding algorithm and 5-round distinguisher of Feistel construction.

2.1 Amplitude Amplification

Amplitude amplification is one of the ways to construct quantum claw finding algorithm, which is proposed by Brassard *et al.* [18].

Theorem 1 [18] *Suppose there is a quantum algorithm $QSearch$ with the following properties. Let A be any quantum algorithm that uses no measurements, and let $X : \{0, 1\} \rightarrow \{0, 1\}$ be any boolean function. p represents the success probability of A of finding a solution (i.e., the probability of outputting z s.t. $X(z) = 1$). The algorithm $QSearch$ needs to execute $O(1/\sqrt{p})$ times A and A^{-1} to find one solution if $p > 0$, otherwise it keeps running.*

Generally speaking, $QSearch$ needs to iterate a certain number of unitary transformation $Q = -AS_0A^{-1}S_X$ on the initial state $A|0\rangle$, where $S_X|z\rangle = (-1)^{X(z)}|z\rangle$, $S_0|0\rangle = -|0\rangle$ and $S_0|z\rangle = |z\rangle$ ($z \neq 0$). The algorithm $QSearch$ needs to iterate $O(1/\sqrt{p})$ times Q to get a solution with high probability. We can obviously find that amplitude amplification can accelerate the algorithm, and Grover algorithm is a special case of amplitude amplification.

2.2 Quantum Claw Finding Algorithm

Suppose there are 2 functions $f : \{0, 1\}^u \rightarrow \{0, 1\}^n$ and $g : \{0, 1\}^v \rightarrow \{0, 1\}^n$. If there is a pair $(x, y) \in \{0, 1\}^u \times \{0, 1\}^v$ which makes $f(x) = g(y)$, then the pair is called a claw of the functions f and g . Therefore, we consider the following problem.

Problem 1 Let u and v be positive integers, given two functions $f : \{0, 1\}^u \rightarrow \{0, 1\}^n$ and $g : \{0, 1\}^v \rightarrow \{0, 1\}^n$, find a claw $(x, y) \in \{0, 1\}^u \times \{0, 1\}^v$ such that $f(x) = g(y)$.

This problem is generally called Claw Finding problem, which has attracted many researchers to solve it. In the field of quantum computation, someone considered this problem in the quantum setting and proposed quantum claw finding algorithm (as shown in Algorithm 1). These studies found that when $u \leq v < 2u$, only $O(2^{(2u+v)/4})$ queries are needed to find a claw, and when $2u \leq v$, only need $O(2^{v/2})$ queries. The quantum claw finding algorithm and its variants have been used in quantum attacks on symmetric cryptosystems.

Algorithm 1: Quantum Claw Finding Algorithm [19]

- 1 Select a random subset $A \subseteq \{0, 1\}^u$ of size 2^l ($l \leq \min\{u, \frac{v}{2}\}$).
 - 2 Select a random subset $B \subseteq \{0, 1\}^v$ of size 2^{2l} .
 - 3 Sort the elements in A according to their f -value.
 - 4 For a specific $b \in B$, check if there is an $a \in A$ such that (a, b) is a claw by using classical binary search on the sorted version of A . Combine this with quantum search on the elements of B to find a claw in $A \times B$.
 - 5 Apply amplitude amplification on steps 1-4.
-

From Algorithm 1, we can see that in step 3, using classical sorting requires $O(2^l \cdot l)$ comparisons. While in step 4, binary search in the sorted set A only requires $O(l)$ comparisons, and using quantum search requires $O(2^l)$ to find a claw between A and B . In general, the time complexity of steps 1-4 is $O(2^l \cdot l)$.

Suppose there is a claw $(x, y) \in \{0, 1\}^u \times \{0, 1\}^v$, then the probability of $(x, y) \in A \times B$ is $2^{l-u} \cdot 2^{2l-v}$. If indeed $(x, y) \in A \times B$, step 4 requires $O(2^l \cdot l)$ comparisons to find the claw with at least $\frac{1}{2}$ probability. Then the probability of successfully finding claw in steps 1-4 is $p = \frac{2^{3l}}{2 \cdot 2^{u+v}}$. Then step 5 needs to iterate $O(\sqrt{\frac{2^{u+v}}{2^{3l}}})$ times from step 1 to step 4. So, a total of $O(\sqrt{\frac{2^{u+v}}{2^l}} \cdot l)$ comparisons are required. When $u \leq v \leq 2u$, $O(\sqrt{\frac{2^{u+v}}{2^l}} \cdot l) \approx O(2^{(2u+v)/4})$. And when $v > 2u$, $O(\sqrt{\frac{2^{u+v}}{2^l}} \cdot l) \approx O(2^{v/2})$.

2.3 5-round Distinguisher

The 5-round distinguisher is the differential characteristics of 5-round Feistel construction proposed by Guo *et al.* [20], which is described by Lemma 1 and Proposition 1. And the differential characteristic is shown in Fig. 1, where v_i ($0 \leq i \leq 6$) is the input of each round, X , X' , 0 and X'' represent differences.

Lemma 1 [20] *Let X and X' , where $X \neq X'$, be two non-zero branch differences. If a 5-round Feistel encrypts a pair of plaintexts (m, m') with a difference $0||X$ to a pair of ciphertexts with difference $0||X'$, then the number of possible internal state values $(v_2, v_3$ and $v_4)$ of the three middle rounds that correspond to the plaintext m is limited to $2^{n/2}$ on average.*

Proof With input difference $0||X$ and output difference $0||X'$ is shown in Fig. 1, we can see that after the first round, the input difference $(0, X)$ must become a state difference $(X, 0)$. Similarly, after the inversion of the last round the output difference $(0, X')$ becomes $(0, X')$. Guo denotes output difference $\Delta F_3^O = X'' = X \oplus X'$ and input difference $\Delta F_3^I = \Delta$ at 3rd round. Then, both output differences ΔF_2^O and ΔF_4^O have same difference Δ . To summarize, we get that for each fixed Δ , the input and output differences of the round functions at rounds 2, 3, and 4 are fixed. Therefore, there exists one state value (one solution) that satisfies such input-output difference in each of the three rounds. Therefore, there exists one state value (one solution) that satisfies such input-output difference in each of the three rounds. As Δ can take at most $2^{n/2}$ different values, the states v_2, v_3 and v_4 can assume $2^{n/2}$ different values.

Proposition 1 [20] Let (m, m') be a pair of plaintexts that conforms to the 5-round distinguisher and $F^\Delta(m, \delta) = \text{Trunc}_{n/2}(F(m) \oplus F(m \oplus (0||\delta)))$, where F is 5-round Feistel, $\text{Trunc}_{n/2}$ is the truncation of the first $n/2$ bits, $m \in \{0, 1\}^n$ and $\delta \in \{0, 1\}^{n/2}$. Let $\delta_j = 1, \dots, 2^b - 1$, $b \geq 1$ form b - δ -sequence. Then, the sequence $F^\Delta(m, \delta_j)$, $\delta_j = 1, \dots, 2^b - 1$ can assume only $2^{n/2}$ possible values.

Proof $F^\Delta(m, \delta)$ gives the output difference of the left half of the pair of the ciphertexts, produced by encryption of a pair of plaintexts $(m, m \oplus (0||\delta))$ with 5 round Feistel. Assume the difference δ is fixed, and let us consider a new pair of plaintexts $F^\Delta(m, \delta_j)$. Finally, $\Delta v_5 = \Delta F_4^O \oplus \Delta F_2^O$. In summary, for an arbitrary δ_j , the mapping from δ_j to Δv_5 becomes deterministic (as long as Δ is fixed). Therefore, the mapping is determined from the value of Δ , X and X' , and acts independently of the value of m . Since Δ takes at most $2^{n/2}$ values, the number of sequences of Δv_5 is limited to $2^{n/2}$. The detailed proof can be seen in Ref. [20].

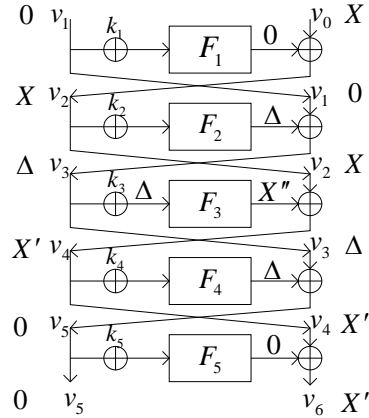

Fig. 1: The differential characteristic of the 5-round Feistel construction.

3 Quantum Meet-in-the-Middle Attack on 7-round Feistel Constructions

Our proposed quantum MITM attack still belongs to the Q1 model, i.e., the adversary can use a quantum computer to perform offline computation, and can only perform classic online queries. Similar to classic meet-in-the-middle attack on the 6-round Feistel construction, our attack is mainly divided into three phases, the online query phase, the offline computation phase and the recovery of keys. And the differential characteristic of the 7-round Feistel construction is shown as below.

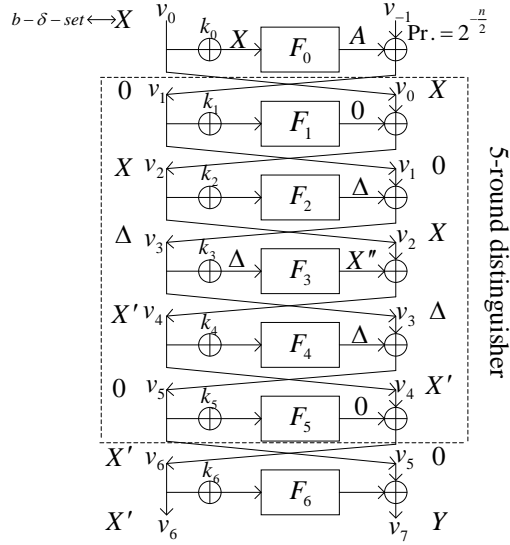

Fig. 2: The differential characteristic of the 7-round Feistel construction.

3.1 Online Query Phase

Firstly, we choose two plaintext sets in the form of $\{v_0||0, v_0||1, \dots, v_0||2^{n/2}-1\}$ and $\{v_0 \oplus X||0, v_0 \oplus X||1, \dots, v_0 \oplus X||2^{n/2}-1\}$, where n represents the length of one block and X has b active bits. After querying these plaintexts, 2^n pairs of ciphertexts with truncated differential X' and Y (as shown in Fig. 2) are obtained. The truncated differences X' and Y satisfy the following Proposition 2.

Proposition 2 Let $\{v_0||0, v_0||1, \dots, v_0||2^{n/2}-1\}$ and $\{v_0 \oplus X||0, v_0 \oplus X||1, \dots, v_0 \oplus X||2^{n/2}-1\}$ be the input plaintexts of the 7-round Feistel construction. Let us

choose $2^{n/2}$ choices of X' ($X' \neq X$). When X' is fixed, the difference Y also has $2^{n/2}$ possible values.

Proof Since $\{v_0||0, v_0||1, \dots, v_0||2^{n/2} - 1\}$ and $\{v_0 \oplus X||0, v_0 \oplus X||1, \dots, v_0 \oplus X||2^{n/2} - 1\}$ can construct 2^n pairs, Δv_{-1} has $2^{n/2}$ values. And the possibility of $\Delta v_{-1} = F_0(v_0 \oplus k_0) \oplus F_0(v_0 \oplus k_0 \oplus X)$ is $2^{-\frac{n}{2}}$. Therefore, there are $2^{n/2}$ pairs that satisfy the input difference of 5-round distinguisher. When X' is fixed, and since Lemma 1 gives that v_3 and v_4 are determined by Δ , $v_6 = v_4 \oplus F_5(v_5 \oplus k_5) = v_4 \oplus F_5(v_3 \oplus F_4(v_4 \oplus k_4) \oplus k_5)$ is also determined by Δ . Due to that Δ has $2^{n/2}$ possible values, v_6 also has $2^{n/2}$ possible values. And due to $Y = \Delta v_7 = F_6(v_6 \oplus k_6 \oplus X') \oplus F_6(v_6 \oplus k_6) \oplus \Delta v_5$ ($\Delta v_5 = 0$ in 5-round distinguisher), the difference Y also has $2^{n/2}$ possible values.

Therefore, the difference between the collected 2^n pairs of ciphertexts will have 2^n possible values. Since X has b active bits, it needs to be queried $2^{n/2+1+b}$ times in total. The time complexity of the entire online query phase is $2^{n/2}$.

3.2 Offline Computation Phase

After getting the 2^n pairs of plaintexts and its corresponding ciphertexts, we need to calculate the difference sequences $\Delta v_5 - sequences$ of each pair with different X ($X \in \{X, X \oplus 1, X \oplus 2, \dots, X \oplus 2^b - 1\}$). Suppose there is a pair of plaintext $m_1 = (v_0, v_{-1})$ and $m_2 = (v_0 \oplus X, v'_{-1})$, and its corresponding ciphertexts $c_1 = (v_6, v_7)$, $c_2 = (v_6 \oplus X', v_7 \oplus Y)$. The difference sequences $\Delta v_5 - sequences$ consist of the differences Δv_5 between $\{m_2^1 = (v_0 \oplus X \oplus 1, v'_{-1}), m_2^2 = (v_0 \oplus X \oplus 2, v'_{-1}), \dots, m_2^{2^b-1} = (v_0 \oplus X \oplus 2^b - 1, v'_{-1})\}$ and $m_1 = (v_0 \oplus X, v'_{-1})$, respectively. It is also the differences Δv_5 between $\{m_1^1 = (v_0 \oplus 1, v_{-1}), m_1^2 = (v_0 \oplus 2, v_{-1}), \dots, m_1^{2^b-1} = (v_0 \oplus 2^b - 1, v_{-1})\}$ and $m_1 = (v_0, v_{-1})$, respectively, i.e.,

$$\Delta v_5 - sequences = \Delta v_5^{m_1 \leftrightarrow m_1^1} || \Delta v_5^{m_1 \leftrightarrow m_1^2} || \dots || \Delta v_5^{m_1 \leftrightarrow m_1^{2^b-1}}, \quad (1)$$

where $\Delta v_5^{m_1 \leftrightarrow m_1^j}$ ($j \in \{1, 2, \dots, 2^b - 1\}$) is the difference between m_1^j and m_1 at v_5 .

$$\Delta v_5^{m_1 \leftrightarrow m_1^j} = F_6(v_6 \oplus k_6) \oplus F_6(v_6^j \oplus k_6) \oplus v_7 \oplus v_7^j, \quad (2)$$

where k_6 is the key of the round function F_6 , $c_1^j = (v_6^j, v_7^j)$ is the ciphertext of m_1^j .

However, the key k_6 is not given. To guess k_6 , the differences Δv_5 of all pairs are set to 0. Then, we can get the input F_6^I of the function F_6 by Eq. 3.

$$F_6(F_6^I) \oplus F_6(F_6^I \oplus X') = \Delta v_5 \oplus Y = Y. \quad (3)$$

Then, the key k_6 can be obtained by Eq. 4.

$$k_6 = F_6^I \oplus v_6. \quad (4)$$

In order to facilitate subsequent computation and reduce time complexity, we need to encode these information into the quantum superposition state and compute on the state directly. Let X' be fixed. The computation process is shown as below.

Step 1. The initial state $|0\rangle^{\otimes n/2}|0\rangle^{\otimes n/2}|0\rangle^{\otimes 2^b n}$ is prepared.

Step 2. Applying a Hadamard transform $H^{\otimes n/2}$ to the first register to obtain the quantum superposition $\sum_{x \in \{0,1\}^{n/2}} \frac{1}{\sqrt{2^{n/2}}} |x\rangle |0\rangle^{\otimes n/2} |0\rangle^{\otimes 2^b n}$.

Step 3. A quantum query to the function f maps this to the state

$$\sum_{x \in \{0,1\}^{n/2}} \frac{1}{\sqrt{2^{n/2}}} |x\rangle |f(x)\rangle |0\rangle^{\otimes 2^b n} = \sum \frac{1}{\sqrt{2^{n/2}}} |F_6^I\rangle |Y\rangle |0\rangle^{\otimes 2^b n}, \quad (5)$$

where the function f is based on Eq. 3, i.e.,

$$f(x) = F_6(x) \oplus F_6(x \oplus X') = Y. \quad (6)$$

Step 4. Encoding the ciphertexts into the state according to different Y values, i.e. $\sum \frac{1}{\sqrt{2^{n/2}}} |F_6^I\rangle |Y\rangle |v_6\rangle |v_7\rangle |v_6^1\rangle |v_7^1\rangle \cdots |v_6^{2^b-1}\rangle |v_7^{2^b-1}\rangle$.

Step 5. Performing XOR operation on $|F_6^I\rangle$ and $|v_6\rangle$, and saving results on the first $n/2$ qubits, i.e.,

$$\begin{aligned} & \sum \frac{1}{\sqrt{2^{n/2}}} |F_6^I \oplus v_6\rangle |Y\rangle |v_6\rangle |v_7\rangle |v_6^1\rangle |v_7^1\rangle \cdots |v_6^{2^b-1}\rangle |v_7^{2^b-1}\rangle \\ &= \sum \frac{1}{\sqrt{2^{n/2}}} |k_6\rangle |Y\rangle |v_6\rangle |v_7\rangle |v_6^1\rangle |v_7^1\rangle \cdots |v_6^{2^b-1}\rangle |v_7^{2^b-1}\rangle. \end{aligned} \quad (7)$$

Step 6. According to Eq. 2, all $\Delta v_5^{m_1 \leftrightarrow m_1^j}$ can be obtained. And discarding the extra useless qubits to get

$$|\Delta v_5 - sequences\rangle = \sum \frac{1}{\sqrt{2^{n/2}}} |Y\rangle \left| \Delta v_5^{m_1 \leftrightarrow m_1^1} \right\rangle \left| \Delta v_5^{m_1 \leftrightarrow m_1^2} \right\rangle \cdots \left| \Delta v_5^{m_1 \leftrightarrow m_1^{2^b-1}} \right\rangle. \quad (8)$$

The above is the whole process of calculating $\Delta v_5 - sequences$, we construct the whole process into a function $g : \{0,1\}^{n/2} \times \{0,1\}^{n/2} \rightarrow \{0,1\}^{(2^b-1)n/2}$, i.e., $g : X' \times Y \rightarrow \Delta v_5 - sequences$.

On the other hand, in addition to computing $\Delta v_5 - sequences$ by collected plaintexts and ciphertexts, it is also necessary to compute $\Delta v_5 - sequences$ through the 5-round distinguisher. That is, we need to compute the differences Δv_5 between $\{v_1 || v_0 \oplus 1, v_1 || v_0 \oplus 2, \dots, v_1 || v_0 \oplus 2^b - 1\}$ and $v_1 || v_0$. Suppose there is a pair $(v_1 || v_0, v_1 || v_0 \oplus j)$ ($j \in \{1, 2, \dots, 2^b - 1\}$), t_2, t_3 and t_4 are the inputs of F_2, F_3 and F_4 respectively. The values of t_2, t_3 and t_4 can be obtained with different X' and Δ by Algorithm 2.

When X' and Δ are fixed, $\Delta v_0 = j$, and the output difference ΔF_1^O of the first round function F_1 in the 5-round distinguisher is always 0. So, $\Delta v_2 = \Delta v_0 = j$. In the second round of 5-round distinguisher, due to $F_2^I = t_2$ and

$\Delta F_2^I = j$, then, $\Delta F_2^O = F_2(t_2) \oplus F_2(t_2 \oplus j)$. And in the 3rd round of 5-round distinguisher, $\Delta F_3^O = F_3(t_3) \oplus F_3(t_3 \oplus \Delta F_2^O)$ because of $F_3^I = t_3$ and $\Delta F_3^I = \Delta F_2^O$. In the next round, $\Delta v_4 = \Delta F_3^O \oplus j$, the output difference of 4th round is $\Delta F_4^O = F_4(t_4) \oplus F_3(t_4 \oplus \Delta F_3^O)$. Finally, we can get the difference of $(v_1 || v_0, v_1 || v_0 \oplus j)$ at v_5 , i.e., $\Delta v_5^j = \Delta F_4^O \oplus \Delta F_2^O$. By repeating this procedure, we can get $\Delta v_5 - sequences$ with fixed X' and Δ .

$$\Delta v_5 - sequences = \Delta v_5^1 || \Delta v_5^2 || \dots || \Delta v_5^{2^b-1} \quad (9)$$

Algorithm 2: The process of searching t_2 , t_3 and t_4 .

```

1 for  $t_2 = 0, 1, \dots, 2^{n/2} - 1$  do
2   if  $\Delta = F_2(t_2) \oplus F_2(t_2 \oplus X)$ 
3     Output  $t_2$ ; Break;
4 for  $t_3 = 0, 1, \dots, 2^{n/2} - 1$  do
5   if  $X'' = F_3(t_3) \oplus F_3(t_3 \oplus \Delta)$ 
6     Output  $t_3$ ; Break;
7 for  $t_4 = 0, 1, \dots, 2^{n/2} - 1$  do
8   if  $\Delta = F_4(t_4) \oplus F_4(t_4 \oplus X')$ 
9     Output  $t_4$ ; Break;
```

Moreover, the $\Delta v_5 - sequences$ with different X' and Δ should all be computed. The whole process can be defined as a new function $f : \{0, 1\}^{n/2} \times \{0, 1\}^{n/2} \rightarrow \{0, 1\}^{(2^b-1)n/2}$, i.e., $f : X' \times \Delta \rightarrow \Delta v_5 - sequences$.

For now, we need to find a claw between the functions f and g , which can be implemented by Algorithm 3.

3.3 Recovery of k_0 and k_6

After obtaining the claw (X', Y, Δ) , we can recover the keys k_0 and k_6 . The key k_6 can be recovered by Eq. 3 and 4 with known X', Y and v_6 (v_6 can be found according to the known X' and Y). Similarly, to recover k_0 , we need to find the plaintext pair $m_1 = (v_0, v_{-1})$ and $m_2 = (v_0 \oplus X, v'_{-1})$ corresponding to the known X' and Y . Then, the input F_0^I of the function F_0 can be obtained when $m_1 = (v_0, v_{-1})$ as the input of 7-round Feistel construction.

$$F_0(F_0^I) \oplus F_0(F_0^I \oplus X) = v_{-1} \oplus v'_{-1} \quad (10)$$

And the key k_0 can be recovered as below,

$$k_0 = F_0^I \oplus v_0. \quad (11)$$

Algorithm 3: Quantum claw finding between the functions f and g .

```

1 for  $X' = 0, 1, \dots, 2^{n/2} - 1$  do
2   Step 1. Select a random set  $\Delta_A \subseteq \{0, 1\}^{n/2}$  of size  $2^{n/4}$ .
3   Step 2. Search  $t_2, t_3$  and  $t_4$  by Grover algorithm, when  $\Delta = \Delta_A$ . And compute
       $\Delta v_5 - \text{sequences}$  with  $t_2, t_3$  and  $t_4$ , i.e.,  $\Delta v_5 - \text{sequences} = f(X', \Delta_A)$ .
4   Step 3. Select a random set  $Y_B \subseteq \{0, 1\}^{n/2}$  of size  $2^{n/2}$ .
5   Step 4. Construct the function  $g$  with  $X'$  and  $Y_B$ .
6   Step 5. Sort the elements in  $\Delta_A$  according  $f(X', \Delta_A)$ .
7   Step 6. For a specific  $Y \in Y_B$ , check if there is an  $\Delta \in \Delta_A$  such that  $(\Delta, Y)$  is
      a claw by using classical binary search on the sorted version of  $\Delta_A$ . Combine
      this with quantum search on the elements of  $Y_B$  to find a claw in  $\Delta_A \times Y_B$ .
8   Step 7. Apply amplitude amplification on Steps 1-6.
9 end
10 Output claw.
```

4 Analysis and Comparison

During the online query phase, our proposed attack only needs $2^{n/2+1+b}$ queries, and store these plaintexts and ciphertexts. So, the time, data and memory complexities of this phase are all $O(2^{n/2})$.

In the offline computation phase, the time complexity is mainly affected by Algorithm 3. In Step 2, it needs to find $O(2^{n/4})$ solutions that satisfy $\Delta = \Delta_A$ from the database with a size of $O(2^{n/2})$ by Grover algorithm, whose time complexity is $O(2^{n/8})$, and it needs to consume $O(n)$ qubits. In Step 4, it only needs to encode information and perform known oracle operation on the state, which is generally considered that its time complexity is $O(1)$ in quantum setting. And in Step 5, the time complexity of sorting is $O(2^{n/4} \cdot \frac{n}{4})$. In next step, through binary search and quantum search, the time complexity is also $O(2^{n/4} \cdot \frac{n}{4})$, and it also needs to consume $O(n)$ qubits. Therefore, the time complexity of Step 1-6 is $O(2^{n/4} \cdot \frac{n}{4})$. After amplitude amplification in Step 7, the time complexity of Step 1-7 is $O(n2^{3n/8})$. Finally, the time complexity of Algorithm 3 is $O(n2^{3n/8} \cdot 2^{n/2}) = O(n2^{7n/8}) \approx O(2^{7n/8})$, and it needs to consume $O(n \cdot 2^{n/2}) = O(n2^{5n/8}) \approx O(2^{5n/8})$ qubits.

To recover k_0 and k_6 , the inputs F_0^I and F_6^I should be found, which can be searched by Grover algorithm. So, the time complexity is $O(2^{n/4})$ and $O(n)$ qubits need to be consumed. In summary, the time, data and memory complexities of our proposed attack are $O(2^{7n/8})$, $2^{n/2}$ and $2^{n/2}$, respectively. And $O(2^{5n/8})$ qubits should be consumed.

Due to that the quantum slide attacks [11, 14] and Hosoyamada *et al.*'s work [15] can not be applied on 7-rounds Feistel construction, we choose the

classic meet-in-the-middle attack [21] and the key recovery attack based on quantum 3-round distinguisher [12], to compare with them as shown in Table 1. Dong *et al.*'s attack [12] is under Q2 model, which analyzes the relationship between the last 4 round keys and ciphertexts based on quantum 3-round distinguisher, and use Grover algorithm to search correct last 4 round keys. Its time and data complexities both are $O(2^n)$. Since the attack directly performs quantum computations on $O(n^2)$ qubits, no memory storage is required. Zhao *et al.*'s classic meet-in-the-middle attack on 7-round Feistel construction [21] is similar to Guo's attack, which use pairs sieve procedure to reduce complexity. Its time and data complexities both are $O(2^n)$. And it needs to store $2^{n/4}$ structures of $2^{n/2}$ plaintexts and ciphertexts. It can be clearly seen that our attack reduces the time complexity from $O(2^n)$ to $O(2^{7n/8})$. Although the iterative use of Grover algorithm in the Algorithm 3 consumes $O(2^{5n/8})$ qubits, our attack belongs to the Q1 model, which has lower requirements on the attacker and is more applicable to actual attacks.

Table 1: Comparison with classic and quantum attacks on 7-round Feistel construction.

	Setting	Time	Data	Memory	Qubits
Dong <i>et al.</i> 's attack [12]	Q2	2^n	2^n	-	n^2
Zhao <i>et al.</i> 's attack [21]	Classic	2^n	2^n	$2^{3n/4}$	-
Our attack	Q1	$2^{7n/8}$	$2^{n/2}$	$2^{n/2}$	$2^{5n/8}$

5 Conclusion

To reduce the time complexity of classic and quantum attacks on 7-round Feistel construction, we propose a quantum meet-in-the-middle attack combining the quantum claw finding algorithm and the 5-round distinguisher in Q1 model. Our proposed attack reduce the time complexity from $O(2^n)$ to $O(2^{7n/8})$ comparing with classic attack and other quantum attacks. And although our attack consumes more qubits, it belongs to the Q1 model, which is more practical.

Furthermore, we hope to carry out quantum meet-in-the-middle attacks on more multi-rounds Feistel constructions. Because there are not only 5-round distinguisher, but also 7-round distinguisher, 8-round distinguisher, etc. Combining these distinguishers with quantum claw finding algorithm, or even other quantum algorithms, may achieve good attack results.

Acknowledgements This work was supported by the 13th Five-Year Plan National Cryptography Development Fund (MMJJ20180217).

References

1. Peter W Shor. Polynomial-time algorithms for prime factorization and discrete logarithms on a quantum computer. *SIAM review*, 41(2):303–332, 1999.
2. Lov K Grover. Quantum computers can search arbitrarily large databases by a single query. *Physical review letters*, 79(23):4709, 1997.
3. Hidenori Kuwakado and Masakatu Morii. Quantum distinguisher between the 3-round feistel cipher and the random permutation. In *2010 IEEE International Symposium on Information Theory*, pages 2682–2685. IEEE, 2010.
4. Daniel R Simon. On the power of quantum computation. *SIAM journal on computing*, 26(5):1474–1483, 1997.
5. Hidenori Kuwakado and Masakatu Morii. Security on the quantum-type even-mansour cipher. In *2012 International Symposium on Information Theory and its Applications*, pages 312–316. IEEE, 2012.
6. Marc Kaplan, Gaëtan Leurent, Anthony Leverrier, and María Naya-Plasencia. Breaking symmetric cryptosystems using quantum period finding. In *Crypto 2016-36th Annual International Cryptology Conference*, pages 207–237. Springer, 2016.
7. Thomas Santoli and Christian Schaffner. Using simon’s algorithm to attack symmetric-key cryptographic primitives. *arXiv preprint arXiv:1603.07856*, 2016.
8. Tairong Shi, Chenhui Jin, and Jie Guan. Collision attacks against aez-prf for authenticated encryption aez. *China Communications*, 15(2):46–53, 2018.
9. Yinsong Xu, Wenjie Liu, and Wenbin Yu. Quantum forgery attacks on copa, aes-copa and marble authenticated encryption algorithms. *Quantum Information Processing*, 20(4):1–21, 2021.
10. Gregor Leander and Alexander May. Grover meets simon—quantumly attacking the fx-construction. In *International Conference on the Theory and Application of Cryptology and Information Security*, pages 161–178. Springer, 2017.
11. Xavier Bonnetain, María Naya-Plasencia, and André Schrottenloher. On quantum slide attacks. In Kenneth G. Paterson and Douglas Stebila, editors, *Selected Areas in Cryptography – SAC 2019*, pages 492–519. Cham, 2020. Springer International Publishing.
12. Xiaoyang Dong and Xiaoyun Wang. Quantum key-recovery attack on feistel structures. *Science China Information Sciences*, 61(10):1–7, 2018.
13. Xiaoyang Dong, Zheng Li, and Xiaoyun Wang. Quantum cryptanalysis on some generalized feistel schemes. *Science China Information Sciences*, 62(2):22501, 2019.
14. Xiaoyang Dong, Bingyou Dong, and Xiaoyun Wang. Quantum attacks on some feistel block ciphers. *Designs, Codes and Cryptography*, 88:1–25, 2020.
15. Akinori Hosoyamada and Yu Sasaki. Quantum demirci-selçuk meet-in-the-middle attacks: applications to 6-round generic feistel constructions. In *International Conference on Security and Cryptography for Networks*, pages 386–403. Springer, 2018.
16. Marc Kaplan, Gaëtan Leurent, Anthony Leverrier, and María Naya-Plasencia. Quantum differential and linear cryptanalysis. *IACR Transactions on Symmetric Cryptology*, 2016(1):71–94, 2016.
17. Huiqin Xie and Li Yang. Using bernstein–vazirani algorithm to attack block ciphers. *Designs, Codes and Cryptography*, 87(5):1161–1182, 2019.
18. Gilles Brassard, Peter Hoyer, Michele Mosca, and Alain Tapp. Quantum amplitude amplification and estimation. *Contemporary Mathematics*, 305:53–74, 2002.
19. Gilles Brassard, Peter Høyer, and Alain Tapp. Quantum cryptanalysis of hash and claw-free functions. *ACM Sigact News*, 28(2):14–19, 1997.
20. Jian Guo, Jérémy Jean, Ivica Nikolić, and Yu Sasaki. Extended meet-in-the-middle attacks on some feistel constructions. *Designs, Codes and Cryptography*, 80(3):587–618, 2016.
21. Shibin Zhao, Xiaohan Duan, Yuanhao Deng, Zhiniang Peng, and Junhu Zhu. Improved meet-in-the-middle attacks on generic feistel constructions. *IEEE Access*, 7:34416–34424, 2019.