

DTGAN: Differential Private Training for Tabular GANs

Aditya Kunar

TU Delft, Delft, Netherlands

A.KUNAR@STUDENT.TUDELFT.NL

Robert Birke

ABB Research Switzerland, Dättwil, Switzerland

ROBERT.BIRKE@CH.ABB.COM

Lydia Y. Chen

TU Delft, Delft, Netherlands

Y.CHEN-10@TUDELFT.NL

Zilong Zhao

TU Delft, Delft, Netherlands

Z.ZHAO-8@TUDELFT.NL

Abstract

Tabular generative adversarial networks (TGAN) have recently emerged to cater to the need of synthesizing tabular data—the most widely used data format. While synthetic tabular data offers the advantage of complying with privacy regulations, there still exists a risk of privacy leakage via inference attacks due to interpolating the properties of real data during training. Differential private (DP) training algorithms provide theoretical guarantees for training machine learning models by injecting statistical noise to prevent privacy leaks. However, the challenges of applying DP on TGAN are to determine the most optimal framework (i.e., PATE/DP-SGD) and neural network (i.e., Generator/Discriminator) to inject noise such that the data utility is well maintained under a given privacy guarantee. In this paper, we propose DTGAN, a novel conditional Wasserstein tabular GAN that comes in two variants $\text{DTGAN}_{\mathcal{G}}$ and $\text{DTGAN}_{\mathcal{D}}$, for providing a detailed comparison of tabular GANs trained using DP-SGD for the generator vs discriminator, respectively. We elicit the privacy analysis associated with training the generator with complex loss functions (i.e., classification and information losses) needed for high quality tabular data synthesis. Additionally, we rigorously evaluate the theoretical privacy guarantees offered by DP empirically against membership and attribute inference attacks. Our results on 3 datasets show that the DP-SGD framework is superior to PATE and that a DP discriminator is more optimal for training convergence. Thus, we find (i) $\text{DTGAN}_{\mathcal{D}}$ is capable of maintaining the highest data utility across 4 ML models by up to 18% in terms of the average precision score for a strict privacy budget, $\epsilon = 1$, as compared to the prior studies and (ii) DP effectively prevents privacy loss against inference attacks by restricting the success probability of membership attacks to be close to 50%.

Keywords: Generative Adversarial Networks, Synthetic Tabular Data, Differential Privacy

1. Introduction

Tabular GANs have shown promising results in terms of learning the original training data distributions and generating high utility synthetic tabular datasets [Xu et al. \(2019\)](#). However, utilising privacy sensitive real datasets to train tabular GANs poses a range of privacy issues. Recent studies have shown that GANs may fall prey to membership and

attribute inference attacks which greatly endanger the personal information present in the real training data [Chen et al. \(2020c\)](#); [Stadler et al. \(2020\)](#). Therefore, it is imperative to safeguard the training of tabular GANs such that it remains protected against malicious privacy attacks to ensure that synthetic data can be stored and shared across different parties without harm.

To address the privacy issues in tabular data, prior work [Jordon et al. \(2018\)](#); [Long et al. \(2019\)](#); [Torkzadehmahani et al. \(2019\)](#); [Torfi et al. \(2020\)](#) relies on Differential Privacy (DP) [Dwork \(2008\)](#) for training tabular GANs in a privacy preserving manner. DP is a mathematical framework that provides theoretical guarantees that bounds the statistical difference between any resulting tabular GAN model trained regardless of the existence of any particular individual’s information in the original training dataset. Typically, this can be achieved by injecting noise while updating the parameters of a network during back-propagation i.e., DP-SGP [Abadi et al. \(2016\)](#); [Xie et al. \(2018\)](#); [Chen et al. \(2020a\)](#), or by injecting noise while aggregating teacher ensembles using the PATE framework [Papernot et al. \(2016\)](#); [Jordon et al. \(2018\)](#). Moreover, as the tabular GAN is composed of generator and discriminator networks, the prior art has two major pathways for training tabular GANs with differential private guarantees: (i) inject noise while training the discriminator [Xie et al. \(2018\)](#) or (ii) inject noise while training the generator [Chen et al. \(2020a\)](#).

However, existing literature does not provide a well defined consensus on which DP framework (i.e., DP-SGD or PATE) is most optimal for training tabular GANs. And, it further remains unclear which network (i.e., discriminator vs generator) must be trained with DP guarantees to generate samples with higher utility while maintaining strict privacy guarantees. In addition, the existing literature rarely investigates the empirical robustness of their differential private GANs against privacy attacks.

In this work, we propose DTGAN, a novel conditional tabular GAN trained with DP-SGD on the Wasserstein loss with gradient penalty [Gulrajani et al. \(2017\)](#). DTGAN has two variants where $\text{DTGAN}_{\mathcal{D}}$ and $\text{DTGAN}_{\mathcal{G}}$ either train the discriminator or generator with DP-SGD, respectively. Moreover, for $\text{DTGAN}_{\mathcal{G}}$, we precisely account for the privacy cost associated with 2 additional loss functions, namely information loss and classification loss, which are used to improve the training of generator network [Park et al. \(2018\)](#). Additionally, to further reduce the privacy cost, we adopt the subsampling technique [Wang et al. \(2019\)](#) to train the discriminator at $\text{DTGAN}_{\mathcal{D}}$ and the generator at $\text{DTGAN}_{\mathcal{G}}$, respectively.

Through our extensive experimental analysis using state-of-the-art DP tabular GAN baselines on 3 datasets and 4 ML models, we show that DP-SGD outperforms the PATE framework. Moreover, we highlight the theoretical and practical considerations for training the discriminator vs generator with DP-SGD. We show that $\text{DTGAN}_{\mathcal{D}}$ produces the best overall data utility by improving upon prior work by 18% in terms of average precision score under a strict privacy budget, $\epsilon = 1$. Furthermore, a rigorous empirical evaluation against privacy attacks reveals that DP guarantees reduce the risk of privacy loss against inference attacks, by effectively limiting the membership attack success rates to approximately 50%.

Our contributions can be summarized as:

- We propose DTGAN a conditional tabular Wasserstein GAN which marries superior quality of synthesized data stemming from complex loss functions with proven privacy guarantees stemming from DP.

- We develop $\text{DTGAN}_{\mathcal{D}}$ and $\text{DTGAN}_{\mathcal{G}}$, two variants of DTGAN, to study the optimal placement of privacy enforcement.
- We extensively evaluate the two variants against 3 baselines on multiple ML utility metrics assessing the performance of models trained on real and generated data, as well as privacy resilience metrics assessing the difficulty to perform membership and attribute inference attacks.

The rest of this paper is organized as follows: Sec. 2 provides a brief background on differential privacy followed by an overview of related work. The two main approaches used to employ differential privacy in T-GAN are elucidated in Sec. 3. Sec. 4, provides a rigorous empirical examination of DTGAN. Finally, Sec. 5 concludes the paper.

2. Background and Related Work

This section presents the notions pertaining to generative adversarial networks, differential privacy and differential private DNN training techniques relevant to this work.

2.1. Generative Adversarial Networks

GAN is a popular algorithm to train generative models. GANs leverage two opposing models: a generator \mathcal{G} and a discriminator \mathcal{D} . The discriminator aims at distinguishing real data from fake data synthesized by the generator. The generator aims at synthesizing data which is indistinguishable from real data to fool the discriminator. The two models are trained together via an adversarial min-max game minimizing the loss of the generator while maximizing the loss of the discriminator.

2.2. Differential Privacy

DP is the golden standard in privacy. DP protects against privacy attacks by minimizing the influence of any individual data under a privacy budget. We leverage the Rényi Differential Privacy (RDP) [Mironov \(2017\)](#) as it provides stricter bounds on the privacy budget. A randomized mechanism \mathcal{M} is (λ, ϵ) -RDP with order λ , if $D_{\lambda}(\mathcal{M}(S) || \mathcal{M}(S')) = \frac{1}{\lambda-1} \log \mathbb{E}_{x \sim \mathcal{M}(S)} \left[\left(\frac{P[\mathcal{M}(S)=x]}{P[\mathcal{M}(S')=x]} \right)^{\lambda-1} \right] \leq \epsilon$ holds for any adjacent datasets S and S' , where $D_{\lambda}(P || Q) = \frac{1}{\lambda-1} \log \mathbb{E}_{x \sim Q} [(P(x)/Q(x))^{\lambda}]$ represents the Rényi divergence. In addition, a (λ, ϵ) -RDP mechanism \mathcal{M} can be expressed as:

$$(\epsilon + \frac{\log 1/\delta}{\lambda-1}, \delta)\text{-DP.} \quad (1)$$

For the purposes of this work \mathcal{M} corresponds to a tabular GAN model and (λ, ϵ) represents the privacy budget. RDP is a strictly stronger privacy definition than DP as it provides tighter bounds for tracking the cumulative privacy loss over a sequence of mechanisms via the Composition theorem [Mironov \(2017\)](#). Let \circ denote the composition operator. For $\mathcal{M}_1, \dots, \mathcal{M}_k$ all (λ, ϵ_i) -RDP, the composition $\mathcal{M}_1 \circ \dots \circ \mathcal{M}_k$ is

$$(\lambda, \sum_i \epsilon_i)\text{-RDP.} \quad (2)$$

Dwork et al. (2014) defines a Gaussian Mechanism \mathcal{M}_σ parameterized by σ as:

$$\mathcal{M}_\sigma(x) = f(x) + \mathcal{N}(0, \sigma^2 I) \quad (3)$$

where f denotes an arbitrary function with sensitivity $\Delta_2 f = \max_{S, S'} \|f(S) - f(S')\|_2$ over all adjacent datasets S and S' , and \mathcal{N} a Gaussian noise with mean 0 and covariance $\sigma^2 I$. \mathcal{M}_σ is $(\lambda, \frac{\lambda \Delta_2 f^2}{2\sigma^2})$ -RDP Mironov (2017).

Two more theorems are important for this work. Post Processing Dwork et al. (2014) states that if \mathcal{M} satisfies (ϵ, δ) -DP, $F \circ \mathcal{M}$ will satisfy (ϵ, δ) -DP. Hence, it suffices to train one of the two networks in the GAN architecture with DP guarantees to ensure that the overall GAN is compatible with differential privacy. RDP for Subsampled Mechanisms Wang et al. (2019) computes the reduction in privacy cost when sub-sampling private data. Formally, let \mathcal{X} be a dataset with n data points and **subsample** return $m \geq n$ subsamples without replacement from \mathcal{D} (subsampling rate $\gamma = m/n$). For all integers $\lambda \geq 2$, if a randomized mechanism \mathcal{M} is $(\lambda, \epsilon(\lambda))$ -RDP, then $\mathcal{M} \circ \mathbf{subsample}$ is

$$(\lambda, \epsilon'(\lambda))\text{-RDP} \quad (4)$$

$$\text{where } \epsilon'(\lambda) \leq \frac{1}{\lambda-1} \log(1 + \gamma^2 \binom{\lambda}{2} \min\{4(e^{\epsilon(2)} - 1), e^{\epsilon(2)} \min\{2, (e^{\epsilon(\infty)} - 1)^2\}\}) + \sum_{j=3}^{\lambda} \gamma^j \binom{\lambda}{j} e^{(j-1)\epsilon(j)} \min\{2, (e^{\epsilon(\infty)} - 1)^j\}$$

2.3. Training with Differential Privacy Guarantees

DP-SGD Abadi et al. (2016) forms the central framework to provide differential privacy guarantees in this work. DP-SGD uses noisy stochastic gradient descent to limit the influence of individual training samples x_i . After computing the gradient $g(x_i)$, the gradient is clipped based on a clipping parameter C and its L2 norm $\bar{g}(x_i) \leftarrow g(x_i) / \max(1, \frac{\|g(x_i)\|_2}{C})$ and Gaussian noise is added $\tilde{g}(x_i) \leftarrow \bar{g}(x_i) + \mathcal{N}(0, \sigma^2 C^2 I)$. \tilde{g} is then used in place of g to update the network parameters as in traditional SGD. \tilde{g} fits the definition of a Gaussian mechanism \mathcal{M}_σ .

One of the biggest challenges with DP-SGD is tuning the clipping parameter C since clipping greatly degrades the information stored in the original gradients Chen et al. (2020a). Choosing an optimal clipping value that does not significantly impact utility is crucial. However, tuning the clipping parameter is laborious as the optimal value fluctuates depending on network hyperparameters (i.e. model architecture, learning rate) Abadi et al. (2016). To avoid an intensive hyper-parameter search, Chen et al. (2020a) proposes to use the Wasserstein loss with a gradient penalty term. This term ensures that the discriminator generates bounded gradient norms which are close to 1 under real and generated distributions. Therefore, an optimal clipping threshold of $C = 1$ is obtained analytically.

2.4. Differential Private Tabular GANs

To avoid leaking sensitive information on single individuals, related work explored several possibilities to provide differential privacy guarantees with GANs. Table 1 provides an overview across the main ingredients used. Both of the two private learning techniques have been applied. Jordon et al. (2018) uses PATE Papernot et al. (2016) which relies on output sanitization perturbing the output of an ensemble of teacher discriminators via

Table 1: Overview of related work.

	Model	DP Algo	Loss*	DP Site	Noise	Accountant	Data Format
	PATE-GAN Jordon et al. (2018)	PATE	KL Divergence	\mathcal{D}	Laplacian	PATE	Table
	DP-WGAN Xie et al. (2018)	DP-SGD	Wasserstein + WC	\mathcal{D}	Gaussian	Moment	Image & Table
	GS-WGAN Chen et al. (2020a)	DP-SGD	Wasserstein + GP	\mathcal{G}	Gaussian	RDP	Image
	RDP-GAN Torfi et al. (2020)	DP-SGD	Wasserstein + WC	\mathcal{D}	Gaussian	RDP	Table
Ours	DTGAN $_{\mathcal{D}}$	DP-SGD	Wasserstein + GP	\mathcal{D}	Gaussian	RDP	Table
	DTGAN $_{\mathcal{G}}$	DP-SGD	Wasserstein + GP	\mathcal{G}	Gaussian	RDP	Table

*WC (Weight Clipping), GP (Gradient Penalty)

Laplacian noise to train a student discriminator scoring the generated samples from the generator. One key limitation is that the student discriminator only sees synthetic data. Since this data is potentially unrealistic the provided feedback can be unreliable. [Xie et al. \(2018\)](#); [Chen et al. \(2020a\)](#); [Torfi et al. \(2020\)](#) use DP-SGD coupled with the Wasserstein loss. Moreover, [Xie et al. \(2018\)](#) uses a momentum accountant whereas [Chen et al. \(2020a\)](#); [Torfi et al. \(2020\)](#) a Rényi differential privacy accountant. The Wasserstein loss is known to be more effective against mode-collapse as compared to the KL divergence [Arjovsky et al. \(2017\)](#). The RDP accountant provides tighter bounds on the privacy costs improving the privacy-utility tradeoff. To incorporate differential privacy guarantees and make the training compatible with the Wasserstein Loss [Xie et al. \(2018\)](#); [Torfi et al. \(2020\)](#) use weight clipping to enforce the Lipschitz constraint. The drawback is the need for careful tuning of the clipping parameter, see Sec. 2.3. To overcome this issue, [Chen et al. \(2020a\)](#) enforces the Lipschitz constraint via a gradient penalty term as suggested by [Gulrajani et al. \(2017\)](#), but addresses only images which are a better fit for GANs and studies its efficacy only for training the generator network.

The proposed DTGAN leverages RDP-based privacy accounting as well as the Wasserstein loss with a gradient penalty for improved privacy accounting and training stability, respectively. However, different from the related work, we tackle differential privacy at both the generator, DTGAN $_{\mathcal{G}}$, and discriminator, DTGAN $_{\mathcal{D}}$, to investigate the most optimal site for integrating DP in tabular GANs. Moreover, we elucidate the privacy cost associated with complex loss functions (i.e., classification and information losses) used by the generator for enhancing the quality of synthetic tabular datasets. Additionally we experimentally validate not only the GAN performance but also the resilience against membership and inference attacks.

3. DTGAN

DTGAN is a novel approach to generate tabular datasets with strong DP guarantees. It utilizes the DP-SGD framework [Abadi et al. \(2016\)](#) and the subsampled RDP moments accountant technique [Mironov \(2017\)](#); [Wang et al. \(2019\)](#) to preserve privacy and account for the cost, respectively. In addition, it makes use of the Wasserstein loss with gradient penalty [Gulrajani et al. \(2017\)](#) to effectively bound the gradient norms thereby providing an analytically derived optimal clipping value for better preserving gradient information after being clipped in regards to DP-SGD as shown in the work of [Chen et al. \(2020a\)](#)

Thus, in Sec. 3.1, we first illustrate the training objectives used by the discriminator and generator respectively. Next, we present the implementation and privacy analysis of

two variants of DTGAN. Sec. 3.2 details training of the discriminator network with DP guarantees whereas Sec. 3.3 describes applying private learning on the generator network. Both approaches are studied to obtain the most optimal configuration for training DTGAN.

3.1. Training Objectives

We change the interpolation method in the Wasserstein with gradient penalty loss function. Originally the authors define the input, i.e. random samples $\hat{x} \sim \mathbb{P}_{\hat{x}}$, as sampling along the straight lines between pair of points sampled from the original data distribution \mathbb{P}_r and the generator distribution \mathbb{P}_g . However, this relies on the assumption that data points form a uniformly distributed hypercube. Since this assumption may not always hold in practice, spherical interpolates [Shoemake \(1985\)](#) are used in this work for accounting the possible curvature of the latent space. This was found to yield better data utility in preliminary experiments. Therefore, the training objectives \mathcal{L}_D and \mathcal{L}_G for the discriminator and generator are expressed as:

$$\mathcal{L}_D = \underbrace{\mathbb{E}_{\tilde{x} \sim \mathbb{P}_g}[D(\tilde{x})] - \mathbb{E}_{x \sim \mathbb{P}_r}[D(x)]}_{\text{Wasserstein loss}} + \underbrace{\tau \mathbb{E}_{\hat{x} \sim \mathbb{P}_{\hat{x}}}[(\|\nabla_{\hat{x}} D(\hat{x})\|_2 - 1)^2]}_{\text{Gradient penalty}} \quad (5)$$

$$\mathcal{L}_G = -\mathbb{E}_{\tilde{x} \sim \mathbb{P}_g}[D(G(\tilde{x}))] \quad (6)$$

where D is the set of 1-Lipschitz functions defining the discriminator network, G represents the generator network and τ is the penalty coefficient.

The generator of DTGAN utilizes two additional loss terms added to (6), known as the classification and information loss, to generate tabular data with greater fidelity than the original [Park et al. \(2018\)](#); [Xu et al. \(2019\)](#). The classification loss $\mathcal{L}_C = \mathbb{E}[|l(\tilde{x}) - C(fe(\tilde{x}))|]_{\tilde{x} \sim \mathbb{P}_g}$ corresponds to training G using the added classifier network, i.e. C , where $l(\cdot)$ is a function that returns the class label of any given data row and $fe(\cdot)$ deletes the class feature of that data row. It quantifies the discrepancy between synthesized and predicted class labels as outputted by an additional classifier module trained to generate predictions using real data. This helps to increase the semantic integrity of synthetic records. The information loss $\mathcal{L}_I = \mathcal{L}_{mean} + \mathcal{L}_{sd}$ where $\mathcal{L}_{mean} = \|\mathbb{E}[f_x]_{x \sim \mathbb{P}_r} - \mathbb{E}[f_{\tilde{x}}]_{\tilde{x} \sim \mathbb{P}_g}\|_2$ and $\mathcal{L}_{sd} = \|\mathbb{SD}[f_x]_{x \sim \mathbb{P}_r} - \mathbb{SD}[f_{\tilde{x}}]_{\tilde{x} \sim \mathbb{P}_g}\|_2$ penalizes the discrepancy between statistics of the generated data and the real data and prevents the generator to over-training on the current discriminator [Salimans et al. \(2016\)](#). f_x and $f_{\tilde{x}}$ denote the resulting features obtained from the penultimate layer of D for a real and generated sample and \mathbb{E} and \mathbb{SD} denote the mean and standard deviations of the features, respectively. Lastly, the generator loss is a by-product of the conditional architecture and is simply used to ensure that the generator respects the conditional constraints imposed during training [Xu et al. \(2019\)](#).

3.2. DP-Discriminator

The first variant, DTGAN $_{\mathcal{D}}$, trains the discriminator using differential private-SGD where the number of training iterations is determined based on the total privacy budget (ϵ, δ) . Thus, to compute the number of iterations, the privacy budget spent for every iteration must be bounded and accumulated. For this purpose we use the subsampled RDP analytical moments accountant technique. The theoretical analysis of the privacy cost is presented below:

Corollary 1 *Each discriminator update satisfies $(\lambda, 2B\lambda/\sigma^2)$ -RDP where B is the batch size.*

Proof Let $f = \text{clip}(\tilde{g}_D, C)$ be the clipped gradient of the discriminator before adding noise. The sensitivity is derived via the triangle inequality:

$$\Delta_2 f = \max_{S, S'} \|f(S) - f(S')\|_2 \leq 2C \quad (7)$$

Since $C = 1$ as a consequence of the Wasserstein loss with gradient penalty and by using (3) the DP-SGD procedure denoted as $\mathcal{M}_{\sigma, C}$ parameterized by noise scale σ and clipping parameter C may be represented as being $(\lambda, 2\lambda/\sigma^2)$ -RDP.

Furthermore, each discriminator update for a batch of real data points $\{x_i, \dots, x_B\}$ can be represented as

$$\tilde{g}_D = \frac{1}{B} \sum_{i=1}^B \mathcal{M}_{\sigma, C}(\nabla_{\theta_D} \mathcal{L}_D(\theta_D, x_i)) \quad (8)$$

where \tilde{g}_D and θ_D represent the perturbed gradients and the weights of the discriminator network, respectively. This may be regarded as a composition of B Gaussian mechanisms and treated via (2). The privacy cost for a single gradient update step for the discriminator can be expressed as $(\lambda, \sum_{i=1}^B 2\lambda/\sigma^2)$ or equivalently $(\lambda, 2B\lambda/\sigma^2)$. ■

Note that $\mathcal{M}_{\sigma, C}$ is only applied for those gradients that are computed with respect to the real training dataset [Abadi et al. \(2016\)](#); [Zhang et al. \(2018\)](#). Hence, the gradients computed with respect to the synthetic data and the gradient penalty term are left undisturbed. Next, to further amplify the privacy protection of the discriminator, we rely on (4) with subsampling rate $\gamma = B/N$ where B is the batch size and N is the size of the training dataset. Intuitively, subsampling adds another layer of randomness and enhances privacy by decreasing the chances of leaking information about particular individuals who are not included in any given subsample of the dataset. Lastly, it is worth mentioning that the Wasserstein loss with gradient penalty training objective has one major pitfall with respect to the privacy cost. This is because, it encourages the use of a stronger discriminator network to provide more meaningful gradient updates to the generator. This requires performing multiple updates to the discriminator for each corresponding update to the generator leading to a faster consumption of the overall privacy budget.

3.3. DP-Generator

The second variant, DTGAN $_G$, trains the generator network with DP guarantees. Fig. 1 depicts the process. The gradients from the discriminator and classifier (i.e., \tilde{g}_G^{Disc} and \tilde{g}_G^{Class}) are selectively perturbed via the same $\mathcal{M}_{\sigma, C}$ DP-SGD procedure which is used for updating the generator’s weights. The selective perturbation of the gradients is necessary as the combined training objective of the generator (i.e., information, classifier and generator loss) does not entirely depend on the original training data. As an example, consider the generator loss which is only used to ensure that the generated data exactly matches the constraint given by the conditional vector sampled randomly during training and as a result,

is independent of the real training data [Xu et al. \(2019\)](#). With this in mind we present the privacy analysis for training the generator via DP-SGD and the subsampled RDP moments accounting.

Corollary 2 *Each generator update satisfies $(\lambda, 6B\lambda/\sigma^2)$ -RDP where B is the batch size.*

Proof Let $f_{Disc} = clip(\bar{g}_G^{Disc}, C)$ be the clipped gradient of the generator computed with respect to \mathcal{L}_G before adding noise. The sensitivity is derived via the triangle inequality:

$$\Delta_2 f_{Disc} = \max_{S, S'} \|f_{Disc}(S) - f_{Disc}(S')\|_2 \leq 2C \quad (9)$$

Since as before $C = 1$ and by using (3) the randomized mechanism $\mathcal{M}_{\sigma, C}$ may similarly be represented as being $(\lambda, 2\lambda/\sigma^2)$ -RDP.

However, due to the addition of the information loss denoted as \mathcal{L}_I , the generator requires an additional fetch of gradients from the discriminator (i.e., g_G^{Disc}) computed with respect to \mathcal{L}_I which in turn doubles the number of times $\mathcal{M}_{\sigma, C}$ is applied. Note that the sensitivity remains the same leading to an identical privacy cost (i.e., $(\lambda, 2\lambda/\sigma^2)$ -RDP).

Likewise for the classifier loss expressed as \mathcal{L}_C , let $f_{Class} = clip(\bar{g}_G^{Class}, C)$ be the clipped gradient of the generator back-propagated from the classifier before adding noise. The sensitivity is similarly derived via the triangle inequality:

$$\Delta_2 f_{Class} = \max_{S, S'} \|f_{Class}(S) - f_{Class}(S')\|_2 \leq 2C \quad (10)$$

For ease of derivation, the clipping parameter for the classifier module is also, $C = 1$. By using (3) once again, $\mathcal{M}_{\sigma, C}$ is $(\lambda, 2\lambda/\sigma^2)$ -RDP.

Thus, to do a single update of the generator’s weights θ_G , the randomized mechanism $\mathcal{M}_{\sigma, C}$ is first applied twice for the discriminator network and once more for the classifier network with a fixed privacy cost of $(\lambda, 2\lambda/\sigma^2)$ -RDP. Formally, this can be expressed as

$$\tilde{g}_G = \sum_{i=1}^L \mathcal{M}_{\sigma, C}(\nabla_{\theta_G} \mathcal{L}_i(\theta_G)) \quad (11)$$

where L represents the set of losses for which the gradients are computed (i.e., $\{\mathcal{L}_G, \mathcal{L}_I, \mathcal{L}_C\}$) and \tilde{g}_G & θ_G represents the perturbed gradients and the weights of the generator network, respectively. This sequence can once again be interpreted as a composition of Gaussian mechanisms which allows the use of (2) to express the cost for an individual data point as $(\lambda, \sum_{i=1}^3 2\lambda/\sigma^2)$ -RDP. And, the privacy cost for a batch of data points $\{x_i, \dots, x_B\}$ can be similarly extended to be $(\lambda, \sum_{i=1}^B \sum_{i=1}^3 2\lambda/\sigma^2)$ or equivalently $(\lambda, 6B\lambda/\sigma^2)$. ■

Next, to amplify the privacy protection for the generator, (4) is analogously used. However, in this case, the original training dataset is divided into disjoint subsets of equal size where a unique discriminator is trained for each subset independently. The size of each subsampled data is defined as N_d/N where N_d is the total number of discriminators and N is the size of the full training dataset. Thus, during training, one out of the total number of discriminators is chosen randomly for every iteration to provide gradient updates

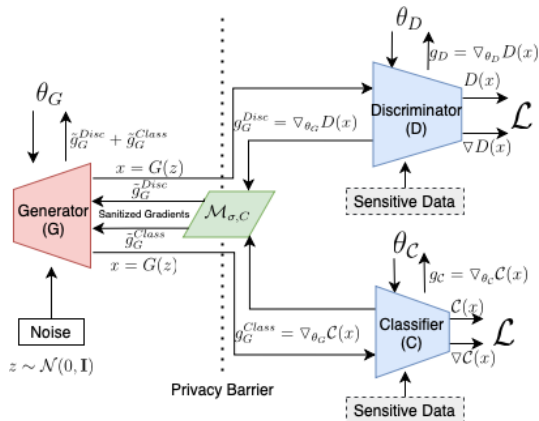

Figure 1: Privacy Preserving Generator

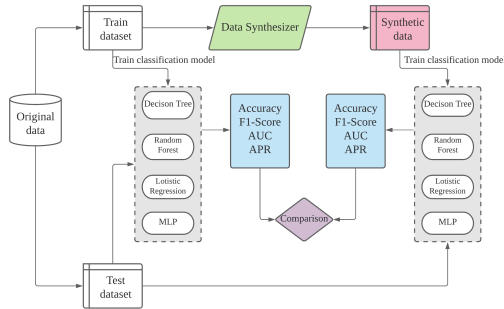

Figure 2: Evaluation flows for ML utility

Table 2: Description of Datasets.

Dataset	Train/Test Split	Target Variable	Continuous	Binary	Multi-class
Adult	39k/9k	“income”	3	2	7
Credit	40k/10k	“Class”	30	1	0
Loan	4k/1k	“PersonalLoan”	5	5	2

to the generator on the basis of the corresponding subsampled dataset. In this way, the subsampling rate for the generator is defined to be $\gamma = 1/N_d$.

Unfortunately, training multiple discriminators on smaller subsamples is problematic due to the lack of enough training iterations for any given discriminator in comparison to the generator. Moreover, reducing the number of samples via subsampling increases the potential of overfitting a discriminator on its respective subsample. [Chen et al.](#) recommends to alleviate the first problem by pre-training multiple discriminator networks with a standard generator without DP. since this does not breach the DP guarantees for the generator. However, in practice, the results were not found to be affected by the presence of pre-trained discriminators in preliminary experiments.

Lastly, (1) is used to convert the overall cumulative privacy cost computed in terms of RDP back to (ϵ, δ) -DP for both approaches.

4. Experimental Analysis

4.1. Experimental Setup

Datasets We evaluate DTGAN using three well-known datasets, i.e., Adult ([Dua and Graff \(2017\)](#)), Credit ([ULB \(2018\)](#)) and Loan ([Jacob \(2019\)](#)). Tab. 2 highlights the salient features of each dataset.

Baselines. Both variants of DTGAN are compared against 2 state-of-the-art architectures: PATE-GAN [Jordon et al. \(2018\)](#) and DP-WGAN [Xie et al. \(2018\)](#). For PATE-GAN we use the original code and parameters provided by the authors. Similarly for DP-WGAN, except that we change the structure of the neural networks to match the ones from PATE-GAN to compare DP-SGD vs PATE frameworks evenly. Note that to compute privacy

cost fairly, the RDP accountant is used for all approaches that use DP-SGD as it provides tighter privacy guarantees than the moment accountant Wang et al. (2019). Lastly, we also feature DTGAN with no privacy budget (i.e., $\epsilon = \infty$) denoted as TGAN.

DTGAN. DTGAN is trained with a gradient penalty coefficient, $\tau = 10$ as recommended by Gulrajani et al. (2017). Batch size is 64 for all models. All other parameters use their default value.

4.2. Evaluation Metrics

We evaluate DTGAN from multiple points of view. On the one hand we check the GAN performance in terms of how similar and useful the generated samples are. On the other hand we evaluate the resilience against two types of privacy attacks.

4.2.1. GAN PERFORMANCE

Machine Learning Utility. To quantify the ML utility, we compare the performance achieved by 4 widely used machine learning algorithms on the real versus the synthetic data: decision tree classifier, random forest classifier, multinomial logistic regression and multi-layer perceptron (MLP). We use Python and scikit-learn 0.24.2. All model hyper-parameters use their default value. Lastly, we apply Min-Max normalisation as pre-processing step.

First we split the original data into training and test sets (see Fig. 2). The training set is used as real data to train the GAN models. Once the training is finished, we use it to synthesize data with the same size as the training set. The synthetic and real training datasets are then used to train pairs of model instances of the 4 machine learning models listed above. We use the test set to compute four performance scores: accuracy, F1-score, area under the ROC (AUC), and average precision score (APR). The ML utility is measured via the difference in each performance score between each model pair trained on the real and synthetic data.

Statistical Similarity. Three metrics are used to quantitatively measure the statistical similarity between the real and synthetic data.

Jensen-Shannon divergence (JSD) Lin (1991). JSD provides a measure to quantify the difference between the probability mass distributions of individual categorical variables belonging to the real and synthetic datasets, respectively. Moreover, this metric is symmetric and bounded between 0 and 1 allowing for an easy interpretation of results.

Wasserstein distance (WD) Ramdas et al. (2017). In similar vein, the Wasserstein distance is used to capture how well the distributions of individual continuous/mixed variables are emulated by synthetically produced datasets in correspondence to real datasets. We use WD because we found that the JSD metric is numerically unstable for evaluating the quality of continuous variables, especially when there is no overlap between the synthetic and original datasets. Note that the WD is calculated after performing a min-max normalisation. This helps in making the wasserstein distances comparable across columns with drastically varying scales.

Difference in pair-wise correlation (Diff. Corr.). To evaluate how well feature interactions are preserved in the synthetic datasets, we compare the pair-wise correlations matrices. We use Pearson correlation coefficient for continuous columns, Theil uncertainty coefficient for categorical columns and correlation ratio between categorical and continuous variables

using the dython library¹. Finally, the l2 norm of the difference between the pair-wise correlation matrices for the real and synthetic datasets is computed.

4.2.2. PRIVACY ATTACKS

Membership Inference Attack Chen et al. (2020b). It is a binary classification problem in which an attacker tries to predict if a particular target data point t has been used to train a victim generative model. This work assumes that the attacker only needs access to a black-box tabular GAN model, a reference dataset \mathcal{R} and t for which the inference must be made Stadler et al. (2020).

To launch an attack, the attacker prepares two training datasets with and without the target record t using the reference dataset \mathcal{R} , i.e. \mathcal{R} , and $\mathcal{R} \oplus t$ (see Fig. 3). Next, the attacker uses black-box access to the model for training two separate models on each dataset. The attacker then uses these to generate s batches of synthetic data each consisting of r rows, represented as \mathcal{S}_r^s . The synthetic batches are assigned a label of 0 and 1, respectively, based on the presence of t in their training dataset. Thereafter, each batch of synthetic data is processed by a feature extraction method summarizing the information contained in each batch into a single vector. This is done in two ways: (i) naive extraction: computes the mean, median, and variance of every continuous column and the length of unique categories as well as the most and least frequently occurring category for every categorical column; (ii) correlation extraction: computes the pairwise correlations between all columns where the categorical columns are dummy-encoded. This leads to the creation of a final dataset, containing an equal number of processed samples. This is split into train and test datasets. An attack model is trained on the training dataset and used to compute the privacy gain as $P_{Gain} = \frac{(P_{Real} - P_{Fake})}{2}$ where P_{Fake} is the attack model’s average probability of successfully predicting the correct label in the test-set and $P_{Real} = 1$ since having access to the original training data ensures full knowledge of t ’s presence Stadler et al. (2020).

To conduct the membership inference evaluation, 4000 rows of real data are sampled from each dataset to form the reference dataset (i.e., \mathcal{R}) to train the synthetic models. Each batch for feature extraction is chosen to be of size $r = 400$. And, $s = 1200$ batches are generated such that the training dataset is of size 1000 with balanced number of classes. And, the test set contains 200 samples with balanced classes. To train the attack model we use the Random-Forest-Classifer. Results are averaged across 5 repetitions with 5 different targets t for each dataset.

Attribute Inference Attack Stadler et al. (2020). It is defined as a regression problem where the attacker attempts to predict the values of a sensitive target column provided he/she has black-box access to a generative model.

To launch an attribute inference attack and evaluate the privacy risk (see Fig. 4), a dataset \mathcal{R} sampled from the real distribution is split into training \mathcal{R}_{Train} and testing \mathcal{R}_{Test} datasets. \mathcal{R}_{Train} is fed into a generative model for generating a corresponding synthetic training dataset (i.e., \mathcal{G}_{Train}). A linear regression model is then used to estimate the relationship between independent variables known to the attacker and the dependent sensitive variable for both \mathcal{R}_{Train} and \mathcal{G}_{Train} . Then, to evaluate the privacy risk, the privacy gain is computed as: $P_{Gain} = \frac{(P_{Real} - P_{Fake})}{2}$, where P_{Real} and P_{Fake} denote the average posterior

1. http://shakedzy.xyz/dython/modules/nominal/#compute_associations

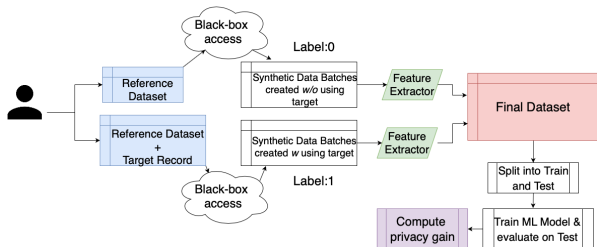

Figure 3: Membership Inference Attack

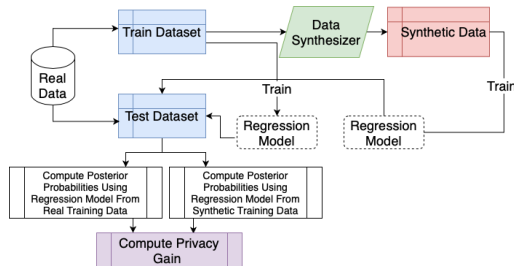

Figure 4: Membership Inference Attack

Table 3: Difference of accuracy (%), F1-score, AUC and APR between original and synthetic data: average over 3 different datasets and a privacy budget $\epsilon = 100$.

Method	$\epsilon = 1$				$\epsilon = 100$			
	Accuracy	AUC	APR	F1-Score	Accuracy	AUC	APR	F1-Score
PATE-GAN	10.8%	0.246	0.576	0.367	37.4%	0.416	0.566	0.412
DP-WGAN	8.2%	0.408	0.58	0.368	10.8%	0.373	0.592	0.364
DTGAN _D	16.1%	0.302	0.483	0.34	13%	0.265	0.475	0.262
DTGAN _G	32.3%	0.377	0.604	0.454	13.7%	0.387	0.565	0.374
TGAN	2.6%	0.042	0.143	0.097	2.6%	0.042	0.143	0.097

probabilities of correctly predicting the sensitive attribute on the real testing set given the linear models fitted on \mathcal{R}_{Train} and \mathcal{G}_{Train} , respectively [Stadler et al. \(2020\)](#).

To perform the attribute inference evaluation, we sample 5000 real rows from each dataset: 4900 samples are used as training dataset (\mathcal{R}_{Train}) and 100 as testing dataset \mathcal{R}_{Test} . Moreover, we chose “Age”, “Age” and “Amount” as sensitive attributes for the Adult, Loan and Credit datasets, respectively. Results are averaged across 5 repetitions.

4.3. Results

This section presents the results for all baselines based on the criteria established previously. Note that for measuring the statistical similarity and ML utility, the privacy budget ϵ is varied between 1 and 100 to study the influence of a strong vs weak privacy constraint, respectively. However, for evaluating the risk of privacy loss via membership and attribute inference attacks, a strict privacy budget of $\epsilon = 1$ is chosen as commonly used in prior work, e.g. [Jordon et al. \(2018\)](#). This is done to thoroughly test experimentally the effectiveness of DP techniques offering strong theoretical guarantees. Note that $\delta = 10^{-5}$ for all experiments and each table features the best results among the models with DP guarantees highlighted in bold.

4.3.1. ML UTILITY

Tab. 3 presents the results for the ML utility across the difference between models trained on original and synthetic data in the four chosen metrics. Ideally the difference should be zero. DTGAN_D achieves the best result in most cases beating both baselines and DTGAN_G. PATE-GAN surprisingly performs worse in terms of ML utility with a looser privacy budget

Table 4: Statistical similarity with different privacy budget ϵ . Results are averaged on 3 datasets. Each experiment repeats 3 times.

Method	$\epsilon = 1$			$\epsilon = 100$		
	Avg JSD	Avg WD	Diff. Corr.	Avg JSD	Avg WD	Diff. Corr.
PATE-GAN	0.487	0.259	3.982	0.358	0.259	4.837
DP-WGAN	0.299	0.232	3.834	0.304	0.222	4.57
DTGAN $_{\mathcal{D}}$	0.246	0.063	4.168	0.127	0.047	3.648
DTGAN $_{\mathcal{G}}$	0.376	0.189	3.065	0.389	0.174	3.21
TGAN	0.028	0.01	1.607	0.028	0.01	1.607

than with a stricter privacy budget. This is mainly because the student discriminator is trained solely with generated samples of poor statistical similarity as found in Tab. 4. Moreover, it is found that only the DTGAN $_{\mathcal{D}}$ model consistently improves across all metrics with a looser privacy budget. It also showcases the best performance for both F1-score and APR metrics across all baselines and privacy budgets. This suggests that training the discriminator with DP guarantees, i.e. DTGAN $_{\mathcal{D}}$, is more optimal than training the discriminator with DP guarantees, i.e. DTGAN $_{\mathcal{G}}$. This is in line with the challenges faced by DTGAN $_{\mathcal{G}}$ due to subsampling which hugely degrades performance by training multiple discriminators each using a smaller number of samples. Finally, the performance increase of DTGAN $_{\mathcal{D}}$ in comparison to other baselines can be explained by its sophisticated neural network architecture (i.e., conditional GAN) and improved training objective (i.e., Wasserstein loss with gradient penalty). However, the cost of applying DP is noticeable by comparing to the DP-unaware TGAN.

4.3.2. STATISTICAL SIMILARITY

The statistical similarity results are summarized in Tab. 4. Among all DP models DTGAN $_{\mathcal{D}}$ is the only model which consistently improves across all three metrics when the privacy budget is increased. Similarly, DTGAN $_{\mathcal{G}}$ sees an improvement across both the Avg-JSD and Avg-WD. The same is not true for PATE-GAN and DP-WGAN where DP-WGAN performs better across all metrics. Moreover, they perform worse than the two variants of DTGAN at both levels of epsilon. This highlights their inability to capture the statistical distributions during training despite a looser privacy budget. This is due to the lack of an effective training framework. Lastly, it is worth noting that DTGAN $_{\mathcal{G}}$ features the best correlation distance at $\epsilon = 1$ and $\epsilon = 100$. It shows that reliably training the discriminator (with DP on the generator) is beneficial for capturing correlations in the data as compared to DTGAN $_{\mathcal{D}}$. Naturally, there is still a significant performance gap with respect to TGAN due to the application of DP.

4.3.3. RESILIENCE AGAINST MEMBERSHIP INFERENCE ATTACK

All DP baselines provide an empirical privacy gain close to 0.25 for both feature extraction methods, see first two results column of Tab. 5. This indicates that differential private methods provide a strong privacy protection against membership attacks. It ensures that the average probability of success for any attack is close to the attacker’s original prior, i.e

Table 5: Empirical privacy gain against membership attack with naive and correlation feature extraction, and attribute inference attack: average over 3 different datasets with privacy budget $\epsilon = 1$.

Method	Naive Privacy Gain	Correlation Privacy Gain	Attribute Inference Privacy Gain
PATE-GAN	0.25	0.25	0.042
DP-WGAN	0.255	0.256	0.04
DTGAN $_{\mathcal{D}}$	0.266	0.248	0.037
DTGAN $_{\mathcal{G}}$	0.245	0.26	0.038
TGAN	0.238	0.233	2e-4

0.5. DTGAN $_{\mathcal{D}}$ and DTGAN $_{\mathcal{G}}$ provide the highest resilience against a membership attack with naive and correlation feature extraction methods, respectively. Moreover, there is a clear decrease in the privacy gain achieved by TGAN showcasing that DP is needed to provide a stronger defense against membership inference attacks.

4.3.4. RESILIENCE AGAINST ATTRIBUTE INFERENCE ATTACK

The last column of Tab. 5 shows the resilience against attribute inference attacks. PATE-GAN provides the greatest resilience, followed by DP-WGAN, DTGAN $_{\mathcal{D}}$, and DTGAN $_{\mathcal{G}}$. This is due to the superior quality of the synthetic data offered which enhances the attacker’s probability of successfully inferring sensitive information. Even if both variants of DTGAN are less resilient than the two DP baselines, the difference with TGAN providing the worst/no resilience is still significant. These results highlight the inherent trade-off between privacy and data utility i.e., increasing the utility directly worsens the privacy and vice versa.

It is worth noting that the privacy gain for attribute inference attack for all baselines is close to 0. This suggests that the overall privacy protection offered against such attacks is quite low. However, it should be noted that the privacy gain is computed with respect to the real data. Thus, in case the real data itself provides a low probability of successfully inferring the correct target values for a sensitive attribute, then the synthetic dataset will perform in a similar manner resulting in a privacy gain close to 0.

5. Conclusion

Motivated by the risk of privacy leakage through synthetic tabular data, we propose a novel DP conditional wasserstein tabular GAN, DTGAN. We rigorously analyze DTGAN using its two variants, namely DTGAN $_{\mathcal{D}}$ and DTGAN $_{\mathcal{G}}$ via the theoretical Rényi DP framework and elicit the privacy cost for additional losses used by the generator to enhance data quality. Moreover, we empirically showcase the data utility achieved by applying DP-SGD to train the discriminator vs generator, respectively. Additionally, we rigorously evaluate the privacy robustness against practical membership and attribute inference attacks.

Our results on three tabular datasets show that synthetic tabular data generated by DP-SGD achieves higher data utility as compared to the PATE framework. Moreover, we find that DTGAN $_{\mathcal{D}}$ outperforms DTGAN $_{\mathcal{G}}$, illustrating that the discriminator trained with DP guarantees is more optimal under stringent privacy budgets. Finally, in terms of data utility

and reliance to privacy attacks, DTGAN \mathcal{D} improves upon prior work by 18% across 4 ML models in terms of the average precision score and all DP baselines reduce the success rate of membership attacks by approx. 50%. Therefore, this work showcases the effectiveness of DP for protecting the privacy of sensitive datasets being used for training tabular GANs. However, further enhancement of the quality of synthetic data at strict privacy budgets (i.e., $\epsilon \leq 1$) is still needed. Ultimately, there is an inherent trade-off between privacy and utility and obtaining the most optimal balance between both is left for future work.

References

- Martin Abadi, Andy Chu, Ian Goodfellow, H Brendan McMahan, Ilya Mironov, Kunal Talwar, and Li Zhang. Deep learning with differential privacy. In *ACM SIGSAC Conference on Computer and Communications Security (CCS)*, pages 308–318, 2016.
- Martin Arjovsky, Soumith Chintala, and Léon Bottou. Wasserstein generative adversarial networks. In *International Conference on Machine Learning (ICML)*, pages 214–223, 2017.
- Dingfan Chen, Tribhuvanesh Orekondy, and Mario Fritz. Gs-wgan: A gradient-sanitized approach for learning differentially private generators. *arXiv preprint arXiv:2006.08265*, 2020a.
- Dingfan Chen, Ning Yu, Yang Zhang, and Mario Fritz. Gan-leaks: A taxonomy of membership inference attacks against generative models. In *ACM SIGSAC Conference on Computer and Communications Security (CCS)*, pages 343–362, 2020b.
- Dingfan Chen, Ning Yu, Yang Zhang, and Mario Fritz. Gan-leaks: A taxonomy of membership inference attacks against generative models. In *ACM SIGSAC Conference on Computer and Communications Security (CCS)*, pages 343–362, 2020c.
- Dheeru Dua and Casey Graff. UCI machine learning repository. <http://archive.ics.uci.edu/ml>, 2017.
- Cynthia Dwork. Differential privacy: A survey of results. In *International Conference on Theory and Applications of Models of Computation (TAMC)*, pages 1–19. Springer, 2008.
- Cynthia Dwork, Aaron Roth, et al. The algorithmic foundations of differential privacy. *Foundations and Trends in Theoretical Computer Science*, 9(3-4):211–407, 2014.
- Ishaan Gulrajani, Faruk Ahmed, Martin Arjovsky, Vincent Dumoulin, and Aaron C Courville. Improved training of wasserstein gans. In *Advances in Neural Information Processing Systems*, pages 5767–5777, 2017.
- Sunil Jacob. Kaggle - personal loan classification problem. <https://www.kaggle.com/itsmesunil/bank-loan-modelling>, 2019.
- James Jordon, Jinsung Yoon, and Mihaela van der Schaar. Pate-gan: Generating synthetic data with differential privacy guarantees. In *International Conference on Learning Representations (ICLR)*, 2018.

- J. Lin. Divergence measures based on the shannon entropy. *IEEE Transactions on Information Theory*, 37(1):145–151, 1991. doi: 10.1109/18.61115.
- Yunhui Long, Suxin Lin, Zhuolin Yang, Carl A Gunter, and Bo Li. Scalable differentially private generative student model via pate. *arXiv preprint arXiv:1906.09338*, 2019.
- Ilya Mironov. Rényi differential privacy. In *Computer Security Foundations Symposium (CSF)*, pages 263–275. IEEE, 2017.
- Nicolas Papernot, Martín Abadi, Ulfar Erlingsson, Ian Goodfellow, and Kunal Talwar. Semi-supervised knowledge transfer for deep learning from private training data. *arXiv preprint arXiv:1610.05755*, 2016.
- Noseong Park, Mahmoud Mohammadi, Kshitij Gorde, Sushil Jajodia, Hongkyu Park, and Youngmin Kim. Data synthesis based on generative adversarial networks. *arXiv preprint arXiv:1806.03384*, 2018.
- Aaditya Ramdas, Nicolás García Trillos, and Marco Cuturi. On wasserstein two-sample testing and related families of nonparametric tests. *Entropy*, 19(2), 2017.
- Tim Salimans, Ian Goodfellow, Wojciech Zaremba, Vicki Cheung, Alec Radford, and Xi Chen. Improved techniques for training gans. In *Advances in Neural Information Processing Systems*, pages 2234–2242, 2016.
- Ken Shoemake. Animating rotation with quaternion curves. In *Conference on Computer Graphics and Interactive Techniques*, pages 245–254, 1985.
- Theresa Stadler, Bristena Oprisanu, and Carmela Troncoso. Synthetic data—a privacy mirage. *arXiv preprint arXiv:2011.07018*, 2020.
- Amirsina Torfi, Edward A Fox, and Chandan K Reddy. Differentially private synthetic medical data generation using convolutional gans. *arXiv preprint arXiv:2012.11774*, 2020.
- Reihaneh Torkzadehmahani, Peter Kairouz, and Benedict Paten. Dp-cgan: Differentially private synthetic data and label generation. In *Conference on Computer Vision and Pattern Recognition (CVPR) Workshops*, pages 98–104, 2019.
- Machine Learning Group ULB. Kaggle - anonymized credit card transactions labeled as fraudulent or genuine. <https://www.kaggle.com/mlg-ulb/creditcardfraud>, 2018.
- Yu-Xiang Wang, Borja Balle, and Shiva Prasad Kasiviswanathan. Subsampled rényi differential privacy and analytical moments accountant. In *International Conference on Artificial Intelligence and Statistics (AISTATS)*, pages 1226–1235, 2019.
- Liyang Xie, Kaixiang Lin, Shu Wang, Fei Wang, and Jiayu Zhou. Differentially private generative adversarial network. *arXiv preprint arXiv:1802.06739*, 2018.
- Lei Xu, Maria Skoularidou, Alfredo Cuesta-Infante, and Kalyan Veeramachaneni. Modeling tabular data using conditional gan. In *Advances in Neural Information Processing Systems*, pages 7335–7345, 2019.

DTGAN

Xinyang Zhang, Shouling Ji, and Ting Wang. Differentially private releasing via deep generative model (technical report). *arXiv preprint arXiv:1801.01594*, 2018.