

Hear Me Out: Fusional Approaches for Audio Augmented Temporal Action Localization

Anurag Bagchi, Jazib Mahmood, Dolton Fernandes, Ravi Kiran Sarvadevabhatla

Centre for Visual Information Technology
International Institute of Information Technology Hyderabad (IIIT-H)
Hyderabad 500032, INDIA
miccooper9@gmail.com,
{jazib.mahmood@research.,dolton.fernandes@research.}@iiit.ac.in,
ravi.kiran@iiit.ac.in
<https://github.com/skelemona/tal-hmo>

Abstract. State of the art architectures for untrimmed video Temporal Action Localization (TAL) have only considered RGB and Flow modalities, leaving the information-rich audio modality totally unexploited. Audio fusion has been explored for the related but arguably easier problem of trimmed (clip-level) action recognition. However, TAL poses a unique set of challenges. In this paper, we propose simple but effective fusion-based approaches for TAL. To the best of our knowledge, our work is the first to jointly consider audio and video modalities for supervised TAL. We experimentally show that our schemes consistently improve performance for state of the art video-only TAL approaches. Specifically, they help achieve new state of the art performance on large-scale benchmark datasets - ActivityNet-1.3 (54.34 mAP@0.5) and THUMOS14 (57.18 mAP@0.5). Our experiments include ablations involving multiple fusion schemes, modality combinations and TAL architectures. Our code, models and associated data will be made available.

1 Introduction

With the boom in online video production, video understanding has become one of the most heavily researched domains in academia. Temporal Action Localization (TAL) is one of the most interesting and challenging problems in the domain. The objective of TAL is to identify and localize actions in a long, untrimmed, real world video. Apart from inheriting the challenges from the related problem of *trimmed* (clip-level) video action recognition, TAL also requires accurate temporal segmentation, i.e. to precisely locate the start time and end time of action categories present in a given video.

TAL is an active area of research and several approaches have been proposed to tackle the problem [1,2,3,4,5,6]. For the most part, existing approaches depend solely on the visual modality (RGB, Optical Flow). An important and obvious source of additional information – the audio modality – has been overlooked.

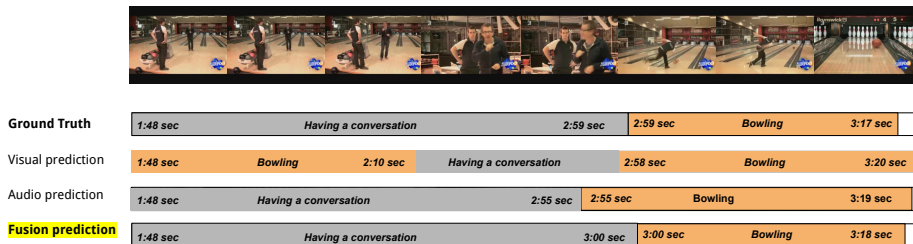

Fig. 1: An example illustrating a scenario where audio modality can help improve performance over video-only temporal action localization.

This is surprising since audio has been shown to be immensely useful for other video-based tasks such as object localization [7], action recognition [8,9,10,11,12] and egocentric action recognition [13].

Analyzing the untrimmed videos, it is evident that the audio track provides crucial complementary information regarding the action classes and their temporal extents. Action class segments in untrimmed videos are often characterized by signature audio transitions as the activity progresses (e.g. the rolling of a ball in a bowling alley culminating in striking of pins, an aquatic diving event culminating with the sound of splash in the water). Depending on the activity, the associated audio features can supplement and complement their video counterparts if the two feature sequences are fused judiciously (Figure 1).

Motivated by observations mentioned above, we make the following contributions:

- We propose simple but effective fusion approaches to combine audio and video modalities for TAL (Section 3). Our work is the first to jointly process audio and video modalities for supervised TAL.
- We show that our fusion schemes can be readily plugged into existing state-of-the-art video based TAL pipelines (Section 3).
- To determine the efficacy of our fusional approaches, we perform comparative evaluation on large-scale benchmark datasets - ActivityNet and THUMOS14. Our results (Section 6) show that the proposed schemes consistently boost performance for state of the art TAL approaches, resulting in an improved mAP of 54.34 for ActivityNet-1.3 and 57.18 mAP for THUMOS14.
- Our experiments include ablations involving multiple fusion schemes, modality combinations and TAL architectures.

We plan to release our code, models and associated data.

2 Related Work

Temporal Action Localization: A popular technique for Temporal Action Localization is inspired from the proposal-based approach for object detection [14]. In this approach, a set of so-called proposals are generated and subsequently

refined to produce the final class and boundary predictions. Many recent approaches employ this proposal-based formulation [15,16,17]. Specifically, this is the case for state-of-the-art approaches we consider in this paper – G-TAD [1], PGCN [2] and MUSES baseline [5]. Both G-TAD [1] and PGCN [2] use graph convolutional networks and the concept of edges to share context and background information between proposals. MUSES baseline [5] on the other hand, achieves state of the art results on the benchmark datasets by employing a temporal aggregation module, originally intended to account for the frequent camera changes in their new multi-shot dataset.

The proposal generation schemes in the literature are either anchor-based [18,19,20] or generate a boundary probability sequence [21,22,23]. Past work in this domain also includes end to end techniques [24,25,26] which combine the two stages. Frame-level techniques which require merging steps to generate boundary predictions also exist [27,28,29]. We augment the proposal-based state of the art approaches designed solely for visual modality by incorporating audio into their architectures.

Audio-based Localization: Speaker diarization [30,31] involves localization of speaker boundaries and grouping segments that belong to the same speaker. The **DCASE Challenge** examines sound event detection in domestic environments as one of the challenge tasks [32,33,34,35,36,37]. In our action localization setting, note that audio modality is unrestricted, i.e. not confined to speech or labelled sound events.

Fusion approaches for TAL: Fusion of multiple modalities is an effective technique for video understanding tasks due to its ability to incorporate all the information available in videos. The fusion schemes present in the literature can be divided into 3 broad categories – *early fusion*, *mid fusion* and *late fusion*.

Late fusion combines the representations closer to the output end from each individual modality stream. When per-modality predictions are fused, this technique is also referred to as *decision level fusion*. *Decision level fusion* is used in I3D [38] which serves as a feature extractor for the current state-of-the-art in TAL. However, unlike the popular classification setting, *decision level fusion* is challenging for TAL since predictions often differ in relative temporal extents. PGCN [39], introduced earlier, solves this problem by performing Non Maximal Suppression on the combined pool of proposals from the two modalities (RGB, Optical Flow). MUSES baseline [5] fuses the RGB and Flow predictions. *Mid fusion* combines mid-level feature representations from each individual modality stream. Feichtenhofer et. al. [40] found that fusing RGB and Optical Flow streams at the last convolutional layer yields good visual modality features. The resulting mid-level features have been successfully employed by well performing TAL approaches [41,42,43,44]. In particular, they are utilized by G-TAD [2] to obtain feature representations for each temporal proposal. *Early fusion* involves fusing the modalities at the input level. In the few papers that compare different fusion schemes [45,46], *early fusion* has been shown to be generally an inferior choice.

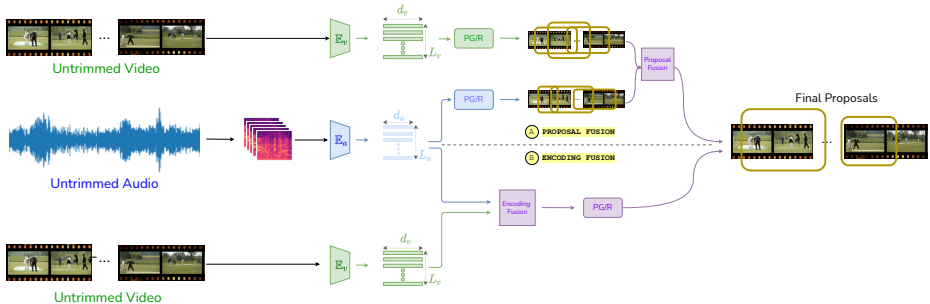

Fig. 2: An illustrative overview of our fusion schemes (Section 3).

Apart from within (visual) modality fusion mentioned above, audio-visual fusion specifically has been shown to benefit (trimmed) clip-level action recognition [9,10,11,13] and audio-visual event localization [47,48,49]. The audio modality has also been shown to be beneficial for the weakly supervised version of TAL [50] wherein the boundary labels for activity instances are absent. However, the lack of labels is a fundamental performance bottleneck compared to the supervised approach.

In our work, we introduce two types of *mid-level fusion* schemes along with *decision level fusion* to combine Audio, RGB and Flow modalities for state of the art supervised Temporal Action Localization.

3 Proposed Fusion Schemes

3.1 Processing stages in video-only TAL

Temporal Action Localisation can be formulated as the task of predicting start and end times (t_s, t_e) and action label a for each action in an untrimmed RGB video $V \in \mathbb{R}^{F \times 3 \times H \times W}$, where F is the number of frames, H and W represent the frame height and width. Despite the architectural differences, state of the art TAL approaches typically consist of three stages: *feature extraction*, *proposal generation* and *proposal refinement*.

The *feature extraction* stage transforms a video into a sequence of feature vectors corresponding to each visual modality (RGB and Flow). Specifically, the feature extractor operates on fixed size snippets $S \in \mathbb{R}^{L \times C \times H \times W}$ and produces a feature vector $f \in \mathbb{R}^{d_v}$. Here, C is the number of channels and L is the number of frames in the snippet. This results in the feature vector sequence $F_v \in \mathbb{R}^{L_v \times d_v}$ mentioned above where L_v is the number of snippets. This stage is shown as the component shaded green (containing \mathbb{E}_v) in Figure 2.

The *proposal generation* stage processes the feature sequence mentioned above to generate action proposals. Each candidate action proposal is associated with temporal extent (start and end time) relative to the input video, and a confidence score. In some approaches, each proposal is also associated with an activity class label.

The *proposal refinement* stage takes the feature sequence corresponding to each candidate proposal as input and refines the boundary predictions and confidence scores. Some approaches modify the class label predictions as well. The final proposals are generally obtained by applying non maximal suppression to weed out the redundancies arising from highly overlapping proposals. Also, note that some approaches do not treat proposal generation and refinement as two different stages. To accommodate this variety, we depict the processing associated with proposal generation and refinement as a single module titled ‘PG/R’ in Figure 2.

3.2 Incorporating Audio

As with video-only TAL approaches, the first stage of audio modality processing consists of extracting a sequence of features from audio snippets (refer to the blue shaded module termed \mathbb{E}_a in Figure 2). This results in the ‘audio’ feature vector sequence $F_a \in \mathbb{R}^{L_a \times d_a}$ mentioned above where L_a is the number of audio snippets and d_a is the length of feature vector for an audio snippet.

Our objective is to incorporate audio as seamlessly as possible into existing video-only TAL architectures. To enable flexible integration, we present two schemes - *proposal fusion* and *encoding fusion*. We describe these schemes next.

3.3 A: Proposal fusion

This is a *decision fusion* approach and as suggested by its name, the basic idea is to merge proposals from the audio and video modalities (see ‘Proposal Fusion’ in Figure 2). To begin with, audio proposals are obtained in a manner similar to the procedure used to obtain video proposals. As mentioned earlier, it is straightforward to fuse action class-level scores since each score vector is of the same length. However, proposals from audio and video modalities consist of variable-length independently generated boundary offsets. This makes the fusion task challenging in the TAL setting.

To solve this problem while adhering to our objective of leaving the existing video-only pipeline untouched, we repurpose the corresponding module from the pipelines. Specifically, we use Non-Maximal Suppression (NMS) for iteratively choosing the best proposals which minimally overlap with other proposals. In some architectures (e.g. PGCN [39]), NMS is applied to separate proposals from RGB and Flow components which contribute together as part of the visual modality. We extend this by initially pooling visual modality proposals with audio counterparts before applying NMS.

3.4 B: Encoding fusion

Instead of the late fusion of per-modality proposals described above, an alternative is to utilize the combined set of audio F_a and video feature sequences F_v to generate a single, unified set of proposals. However, since the encoded representation dimensions d_a, d_v and the number of sequence elements L_a, L_v can be

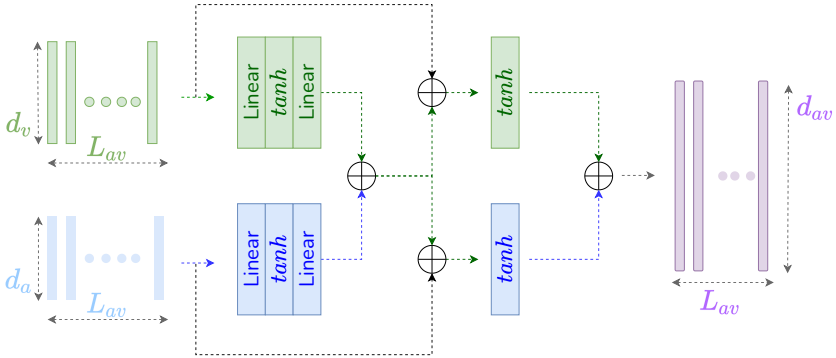

Fig. 3: Residual Multimodal Attention mechanism with video-only and audio features as a form of encoding fusion (Section 3.4). \oplus indicates tensor addition.

unequal, standard dimension-wise concatenation techniques are not applicable. To tackle this issue, we explore four approaches to make the sequence lengths equal for feature fusion (depicted as purple block titled ‘Encoding Fusion’ in Figure 2).

For the first two approaches, we revisit the feature extraction phase and extract audio features at the frame rate used for videos. As a result, we obtain a paired sequence of audio and video snippets (i.e. $L_a = L_v$).

- **Concatenation (Concat):** The paired sequences are concatenated along the feature dimension.
- **Residual Multimodal Attention (RMAttn):** To refine each modality’s representation using features from other modality, we employ a residual multimodal attention mechanism [46] as shown in Figure 3.

The other two encoding fusion approaches:

- **Duplicate and Trim (DupTrim):** Suppose $L_v < L_a$ and $k = \frac{L_a}{L_v}$. We first duplicate each visual feature to obtain a sequence of length kL_v . We then trim both the audio and visual feature sequences to a common length $L_m = \min(L_a, kL_v)$. A similar procedure is followed for the other case ($L_a < L_v$).
- **Average and Trim (AvgTrim):** Suppose $L_v < L_a$ and $k = \frac{L_a}{L_v}$. We group audio features into subsequences of length $k' = \lceil k \rceil$. We then form a new feature sequence of length L'_a by averaging each k' -sized group. Following a procedure similar to ‘DupTrim’ above, we trim the modality sequences to a common length, i.e. $L_m = \min(L'_a, L_v)$.

For the above approaches involving trimming, the resulting audio and video sequences are concatenated along the feature dimension to obtain the fused multimodal feature sequence.

For all the approaches, the resulting fused representation is processed by a ‘PG/R’ (proposal generation and refinement) module to obtain the final predictions, similar to its usage mentioned earlier (see Figure 2). Apart from the fusion

Dataset	Setup Id	Architecture	Visual Features	+Audio			
				mAP	mAP	fusion scheme	fusion type
THUMOS14[51]	1	GTAD[2]	TSN[52]	40.20	42.01	encoding	Concat
	2	PGCN[39]	TSP [53]	53.50	53.96	encoding	AvgTrim
	3	MUSES[5]	I3D[38]	56.16 ^a	57.18	encoding	Concat
ActivityNet-1.3[54]	1	GTAD[2]	GES[55]	41.50 ^b	42.17	encoding	Concat
	2	GTAD[2]	TSP [53]	51.26	54.34	encoding	RMAttn

Table 1: Architectural pipeline components for top-performing TAL approaches. To reduce clutter, only mAP@0.5 is reported. The ‘+Audio’ group refers to the fusion configuration corresponding to the best results (Section 3). Please see Supplementary for a larger table with other configurations and combinations.

^a From our best run using the official code from [5]. In the paper, reported mAP is 56.90.

^b The result is obtained by repeating the evaluation on the set of videos currently available.

schemes, we also note that each scheme involves additional choices. In our experiments, we perform comparative evaluation for all the resulting combinations.

4 Implementation Details

TAL video-only architectures: To determine the utility of audio modality and to ensure our method is easily applicable to any video-only TAL approach, we do not change the architectures and hyperparameters (e.g. snippet length, frame rate, optimizers) for the baselines. The feature extraction components of the baselines are summarized in Table 1.

Audio extraction: For audio, we use VGGish [56], a state of the art approach for audio feature extraction. We use a sampling rate of 16kHz to extract the audio signal and extract 128-D features from 1.2s long snippets. For experiments involving attentional fusion, we extract features by centering the 1.2s window about the snippets used for video feature extraction so as to maintain the same feature sequence length for audio and video modalities. Windows shorter than 1.2s (a few starting and ending ones) are padded with zeros at the end to specify that no more information is present and to match the 1.2s window requirement. Although the opposite (i.e. changing sampling rate for video, keeping the audio setup unchanged) is possible, we prefer the former since the video-only architecture and (video) data processing can be used as specified originally, without worrying about the consequences of such a change on the existing video-only architectural setup and hyperparameter choices.

Proposal Generation and Refinement (PG/R): For proposal generation, we consider state of the art architectures GTAD[1], BMN[22] and BSN[21]. Similarly, for proposal refinement, we consider PGCN[2] and MUSES[5] in our experiments with audio.

Optimization: We train all the architectures except PGCN and GTAD with their original setting. We use a batch size of 256 for PGCN[2] and 16 for GTAD[1]. For training, we use 4 GeForce 2080Ti 11GB GPUs. The entire code-base is based on Pytorch library except for VGGish [56] which is based on Keras.

5 Experiments

5.1 Datasets

To compare our results with the SOTA architectures in which we incorporate audio, we evaluate our models on two benchmark datasets for temporal action localisation.

THUMOS14[51] contains 1010 untrimmed videos for validation and 1574 for testing. Of these, 200 validation and 213 testing videos contain temporal annotations spanning 20 activity categories. Following the standard setup [1,2], we use the 200 validation videos for training and the 213 testing videos for evaluation.

ActivityNet-1.3[54] contains 20k untrimmed videos with 200 action classes between its training, validation and testing sets. Once again, following the standard setup [1,2], we train on 10024 videos and test on the 4926 videos from the validation set.

5.2 Evaluation Protocol

We label a temporal (proposal) prediction (with associated start and end time) as correct if (i) its Intersection Over Union (IOU) with ground-truth exceeds a pre-determined threshold (ii) proposal’s label matches the ground truth counterpart. Following standard protocols, we evaluate the mean Average Precision (mAP) scores at IOU thresholds from 0.3 to 0.7 with a step of 0.1 for THUMOS14 [51] and {0.5, 0.75, 0.95} for ActivityNet-1.3 [54].

6 Results

The mAP@0.5 results of the best fusion approach for each video-only baseline can be seen in Table 1. It can be seen that incorporating audio consistently improves performance across all approaches. In particular, this incorporation results in a new state-of-the-art result on both the benchmark TAL datasets. In terms of fusion approaches, the clear dominance of encoding fusion scheme (Section 3.4) can be seen. The Residual Multimodal Attention mechanism from this scheme enables best performance for the relatively larger ActivityNet-1.3 dataset. Similarly, our mechanism of resampling the audio modality followed by concatenation of per-modality features enables best performance for the THUMOS14 dataset. A fuller comparison of the existing best video-only and best audio-visual results obtained via our work can be seen in Tables 2,3. The results once again reinforce the utility of audio for TAL.

		mAP@IoU					
Architecture	Visual	Audio	0.3	0.4	0.5	0.6	0.7
MUSES[2]	I3D[38]	–	67.91	63.15	56.16	46.07	29.89
MUSES[5]	I3D[38]	VGGish[56] Encoding Fusion (Concat -Sec. 3.4)	70.18	64.98	57.18	45.42	28.86

Table 2: [THUMOS14] mAP for top performers of video-only and audio-visual fusional approach.

		mAP@IoU				
Architecture	Visual	Audio	0.5	0.75	0.95	avg.
GTAD[2]	TSP [53]	–	51.26	37.12	9.29	35.01
GTAD[5]	TSP[55]	VGGish[56] RMAttn (Sec. 3.4)	54.34	37.66	8.93	36.82

Table 3: [ActivityNet-1.3] mAP for top performers of video-only and audio-visual fusional approach.

Per class analysis: To examine the effect of audio at the action class level, we plot the change in Average Precision (AP) relative to the video-only score for the best performing setup. Figure 4 depicts the plot for ActivityNet-1.3, sorted in decreasing order of AP improvement. The majority of action classes show positive AP improvement. This correlates with observations made in the context of aggregate performance (Table 1, Table 3). The action classes which benefit the most from audio (e.g. ‘Playing Ten Pins’, ‘Curling’, ‘Blow-drying hair’) tend to have signature audio transitions marking the beginning and end of the action. The classes at the opposite end (e.g. ‘Painting’, ‘Doing nails’, ‘Putting in contact lenses’) are characterized by very little association between visual and audio modalities. For these classes, it is likely that ambient background sounds are present which induce noisy features. However, the gating mechanism enabled by Residual Multimodal Attention ensures that the effect of such noise from the modalities is appropriately mitigated. This can be seen from the smaller magnitude of drop in AP.

Figure 5 depicts the sorted AP improvement plot for the relatively smaller THUMOS14 dataset. Similar qualitative trends – signature audio transitions characterizing largest AP improvement classes and weak inter-modality associations characterizing least AP improvement classes – can be seen.

7 Conclusion

In this paper, we have presented multiple simple but effective fusion schemes for incorporating audio into existing video-only TAL approaches. To the best of

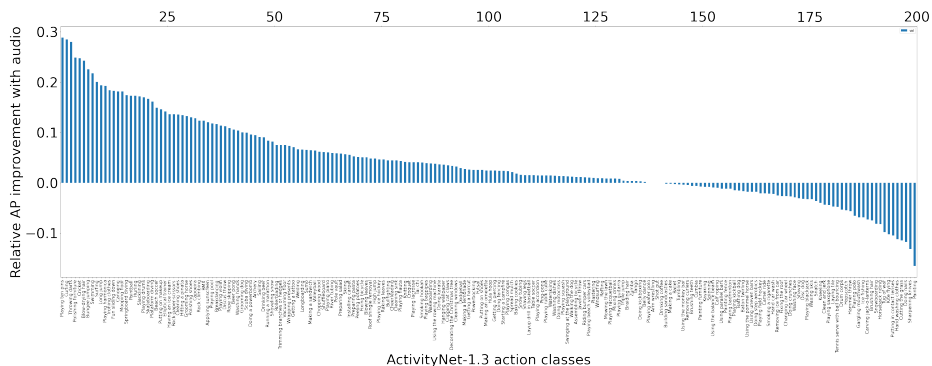

Fig. 4: [ActivityNet-1.3] Relative change in per-class AP of the best multimodal setup (Table 1) with inclusion of audio.

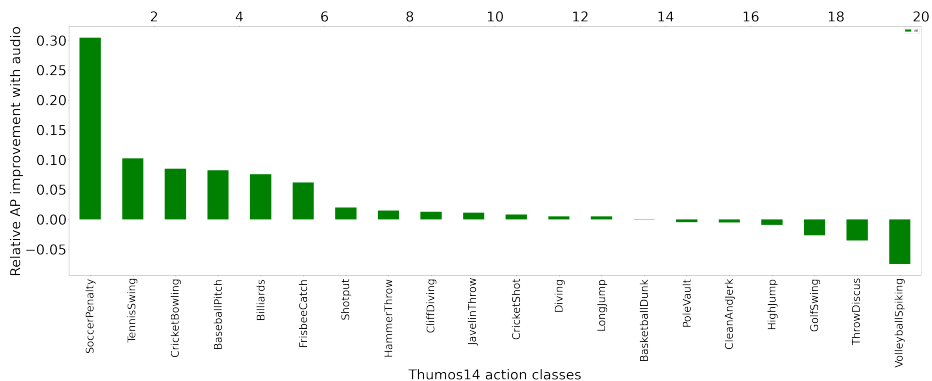

Fig. 5: [THUMOS14] Relative change in per-class AP of the best multimodal setup (Table 1) with inclusion of audio.

our knowledge, our effort is the first of its kind for fully supervised TAL. An advantage of our schemes is that they can be readily incorporated into a variety of video-only TAL architectures – a capability we expect to be available for future approaches as well. Experimental results on two large-scale benchmark datasets demonstrate consistent gains due to our fusion approach over video-only methods and state-of-the-art performance. Our analysis also sheds light on the impact of audio availability on overall as well as per-class performance. Going ahead, we plan to expand and improve the proposed families of fusion schemes.

References

- Xu, M., Zhao, C., Rojas, D.S., Thabet, A.K., Ghanem, B.: G-TAD: sub-graph localization for temporal action detection. CoRR **abs/1911.11462** (2019) 1, 3, 7, 8

2. Zeng, R., Huang, W., Tan, M., Rong, Y., Zhao, P., Huang, J., Gan, C.: Graph convolutional networks for temporal action localization. CoRR **abs/1909.03252** (2019) [1](#), [3](#), [7](#), [8](#), [9](#)
3. Alwassel, H., Giancola, S., Ghanem, B.: TSP: temporally-sensitive pretraining of video encoders for localization tasks. CoRR **abs/2011.11479** (2020) [1](#)
4. Liu, X., Hu, Y., Bai, S., Ding, F., Bai, X., Torr, P.H.S.: Multi-shot temporal event localization: a benchmark. CoRR **abs/2012.09434** (2020) [1](#)
5. Liu, X., Hu, Y., Bai, S., Ding, F., Bai, X., Torr, P.H.S.: Multi-shot temporal event localization: a benchmark (2021) [1](#), [3](#), [7](#), [9](#)
6. Lin, C., Xu, C., Luo, D., Wang, Y., Tai, Y., Wang, C., Li, J., Huang, F., Fu, Y.: Learning salient boundary feature for anchor-free temporal action localization. In: Proceedings of the IEEE/CVF Conference on Computer Vision and Pattern Recognition (CVPR). (June 2021) 3320–3329 [1](#)
7. Arandjelovic, R., Zisserman, A.: Look, listen and learn. CoRR **abs/1705.08168** (2017) [2](#)
8. Owens, A., Efros, A.A.: Audio-visual scene analysis with self-supervised multisensory features. CoRR **abs/1804.03641** (2018) [2](#)
9. Wu, Z., Jiang, Y.G., Wang, X., Ye, H., Xue, X.: Multi-stream multi-class fusion of deep networks for video classification. In: Proceedings of the 24th ACM International Conference on Multimedia. MM '16, New York, NY, USA, Association for Computing Machinery (2016) 791–800 [2](#), [4](#)
10. Long, X., Gan, C., de Melo, G., Wu, J., Liu, X., Wen, S.: Attention clusters: Purely attention based local feature integration for video classification (2017) [2](#), [4](#)
11. Long, X., Gan, C., De Melo, G., Liu, X., Li, Y., Li, F., Wen, S.: Multimodal keyless attention fusion for video classification. In: 32nd AAAI Conference on Artificial Intelligence, AAAI 2018. 32nd AAAI Conference on Artificial Intelligence, AAAI 2018, AAAI press (2018) 7202–7209 32nd AAAI Conference on Artificial Intelligence, AAAI 2018 ; Conference date: 02-02-2018 Through 07-02-2018. [2](#), [4](#)
12. Owens, A., Wu, J., McDermott, J.H., Freeman, W.T., Torralba, A.: Ambient sound provides supervision for visual learning. CoRR **abs/1608.07017** (2016) [2](#)
13. Kazakos, E., Nagrani, A., Zisserman, A., Damen, D.: Epic-fusion: Audio-visual temporal binding for egocentric action recognition (2019) [2](#), [4](#)
14. Girshick, R.: Fast r-cnn. In: Proceedings of the IEEE international conference on computer vision. (2015) 1440–1448 [2](#)
15. Shou, Z., Wang, D., Chang, S.: Action temporal localization in untrimmed videos via multi-stage cnns. CoRR **abs/1601.02129** (2016) [3](#)
16. Zhao, Y., Xiong, Y., Wang, L., Wu, Z., Lin, D., Tang, X.: Temporal action detection with structured segment networks. CoRR **abs/1704.06228** (2017) [3](#)
17. Xu, H., Das, A., Saenko, K.: R-C3D: region convolutional 3d network for temporal activity detection. CoRR **abs/1703.07814** (2017) [3](#)
18. Gao, J., Yang, Z., Sun, C., Chen, K., Nevatia, R.: TURN TAP: temporal unit regression network for temporal action proposals. CoRR **abs/1703.06189** (2017) [3](#)
19. Gao, J., Chen, K., Nevatia, R.: CTAP: complementary temporal action proposal generation. CoRR **abs/1807.04821** (2018) [3](#)
20. Liu, Y., Ma, L., Zhang, Y., Liu, W., Chang, S.: Multi-granularity generator for temporal action proposal. CoRR **abs/1811.11524** (2018) [3](#)
21. Lin, T., Zhao, X., Su, H., Wang, C., Yang, M.: BSN: boundary sensitive network for temporal action proposal generation. CoRR **abs/1806.02964** (2018) [3](#), [7](#)
22. Lin, T., Liu, X., Li, X., Ding, E., Wen, S.: BMN: boundary-matching network for temporal action proposal generation. CoRR **abs/1907.09702** (2019) [3](#), [7](#)

23. Su, H., Gan, W., Wu, W., Yan, J., Qiao, Y.: BSN++: complementary boundary regressor with scale-balanced relation modeling for temporal action proposal generation. CoRR **abs/2009.07641** (2020) [3](#)
24. Buch, S., Escorcia, V., Ghanem, B., Fei-Fei, L., Niebles, J.: End-to-end, single-stream temporal action detection in untrimmed videos. In: Proceedings of the British Machine Vision Conference 2017, British Machine Vision Association (2019) [3](#)
25. Yeung, S., Russakovsky, O., Mori, G., Fei-Fei, L.: End-to-end learning of action detection from frame glimpses in videos. CoRR (2015) [3](#)
26. Lin, T., Zhao, X., Shou, Z.: Single shot temporal action detection. CoRR **abs/1710.06236** (2017) [3](#)
27. Shou, Z., Chan, J., Zareian, A., Miyazawa, K., Chang, S.: CDC: convolutional-de-convolutional networks for precise temporal action localization in untrimmed videos. CoRR **abs/1703.01515** (2017) [3](#)
28. Montes, A., Salvador, A., Gir6-i-Nieto, X.: Temporal activity detection in untrimmed videos with recurrent neural networks. CoRR **abs/1608.08128** (2016) [3](#)
29. Zeng, R., Gan, C., Chen, P., Huang, W., Wu, Q., Tan, M.: Breaking winner-takes-all: Iterative-winners-out networks for weakly supervised temporal action localization. IEEE Transactions on Image Processing **28**(12) (2019) 5797–5808 [3](#)
30. Wang, Q., Downey, C., Wan, L., Mansfield, P.A., Moreno, I.L.: Speaker diarization with lstm (2018) [3](#)
31. Zhang, A., Wang, Q., Zhu, Z., Paisley, J., Wang, C.: Fully supervised speaker diarization (2019) [3](#)
32. Miyazaki, K., Komatsu, T., Hayashi, T., Watanabe, S., Toda, T., Takeda, K.: Convolution-augmented transformer for semi-supervised sound event detection. Technical report, DCASE2020 Challenge (June 2020) [3](#)
33. Hao, J., Hou, Z., Peng, W.: Cross-domain sound event detection: from synthesized audio to real audio. Technical report, DCASE2020 Challenge (June 2020) [3](#)
34. Ebberts, J., Haeb-Umbach, R.: Convolutional recurrent neural networks for weakly labeled semi-supervised sound event detection in domestic environments. Technical report, DCASE2020 Challenge (June 2020) [3](#)
35. Lin, L., Wang, X.: Guided learning convolution system for dcase 2019 task 4. Technical report, Institute of Computing Technology, Chinese Academy of Sciences, Beijing, China (June 2019) [3](#)
36. Delphin-Poulat, L., Plapous, C.: Mean teacher with data augmentation for dcase 2019 task 4. Technical report, Orange Labs Lannion, France (June 2019) [3](#)
37. Shi, Z.: Hodgepodge: Sound event detection based on ensemble of semi-supervised learning methods. Technical report, Fujitsu Research and Development Center, Beijing, China (June 2019) [3](#)
38. Carreira, J., Zisserman, A.: Quo vadis, action recognition? a new model and the kinetics dataset (2018) [3](#), [7](#), [9](#)
39. Zeng, R., Huang, W., Tan, M., Rong, Y., Zhao, P., Huang, J., Gan, C.: Graph convolutional networks for temporal action localization. In: ICCV. (2019) [3](#), [5](#), [7](#)
40. Feichtenhofer, C., Pinz, A., Zisserman, A.: Convolutional two-stream network fusion for video action recognition (2016) [3](#)
41. Lin, C., Li, J., Wang, Y., Tai, Y., Luo, D., Cui, Z., Wang, C., Li, J., Huang, F., Ji, R.: Fast learning of temporal action proposal via dense boundary generator (2019) [3](#)
42. Lin, T., Liu, X., Li, X., Ding, E., Wen, S.: Bmn: Boundary-matching network for temporal action proposal generation (2019) [3](#)

43. Lin, T., Zhao, X., Su, H., Wang, C., Yang, M.: Bsn: Boundary sensitive network for temporal action proposal generation (2018) [3](#)
44. Li, X., Lin, T., Liu, X., Gan, C., Zuo, W., Li, C., Long, X., He, D., Li, F., Wen, S.: Deep concept-wise temporal convolutional networks for action localization (2019) [3](#)
45. Jiang, H., Li, Y., Song, S., Liu, J. In: Rethinking Fusion Baselines for Multi-modal Human Action Recognition: 19th Pacific-Rim Conference on Multimedia, Hefei, China, September 21-22, 2018, Proceedings, Part III. (09 2018) 178–187 [3](#)
46. Tian, Y., Shi, J., Li, B., Duan, Z., Xu, C.: Audio-visual event localization in unconstrained videos (2018) [3](#), [6](#)
47. Zhou, J., Zheng, L., Zhong, Y., Hao, S., Wang, M.: Positive sample propagation along the audio-visual event line. In: Proceedings of the IEEE Conference on Computer Vision and Pattern Recognition (CVPR). (2021) [4](#)
48. He, Y., Xu, X., Liu, X., Ou, W., Lu, H.: Multimodal transformer networks with latent interaction for audio-visual event localization. In: 2021 IEEE International Conference on Multimedia and Expo (ICME), IEEE (2021) 1–6 [4](#)
49. Xu, H., Zeng, R., Wu, Q., Tan, M., Gan, C.: Cross-modal relation-aware networks for audio-visual event localization. In: Proceedings of the 28th ACM International Conference on Multimedia. (2020) 3893–3901 [4](#)
50. Lee, J.T., Jain, M., Park, H., Yun, S.: Cross-attentional audio-visual fusion for weakly-supervised action localization. In: International Conference on Learning Representations. (2021) [4](#)
51. Jiang, Y.G., Liu, J., Roshan Zamir, A., Toderici, G., Laptev, I., Shah, M., Sukthankar, R.: THUMOS challenge: Action recognition with a large number of classes. <http://crcv.ucf.edu/THUMOS14/> (2014) [7](#), [8](#)
52. Wang, L., Xiong, Y., Wang, Z., Qiao, Y., Lin, D., Tang, X., Gool, L.V.: Temporal segment networks: Towards good practices for deep action recognition (2016) [7](#)
53. Alwassel, H., Giancola, S., Ghanem, B.: Tsp: Temporally-sensitive pretraining of video encoders for localization tasks. arXiv preprint arXiv:2011.11479 (2020) [7](#), [9](#)
54. Caba Heilbron, F., Escorcia, V., Ghanem, B., Carlos Niebles, J.: Activitynet: A large-scale video benchmark for human activity understanding. In: Proceedings of the IEEE Conference on Computer Vision and Pattern Recognition (CVPR). (June 2015) [7](#), [8](#)
55. Xiong, Y., Wang, L., Wang, Z., Zhang, B., Song, H., Li, W., Lin, D., Qiao, Y., Gool, L.V., Tang, X.: Cuhk & ethz & siat submission to activitynet challenge 2016 (2016) [7](#), [9](#)
56. Hershey, S., Chaudhuri, S., Ellis, D.P., Gemmeke, J.F., Jansen, A., Moore, R.C., Plakal, M., Platt, D., Saurous, R.A., Seybold, B., et al.: Cnn architectures for large-scale audio classification. In: 2017 IEEE International Conference on Acoustics, Speech and Signal Processing (ICASSP), IEEE (2017) 131–135 [7](#), [8](#), [9](#)