

# Generating Extended Resolution Proofs with a BDD-Based SAT Solver (Extended Version)

Randal E. Bryant  
Marijn J. H. Heule  
Carnegie Mellon University  
Pittsburgh, PA 15213 USA  
{Randy.Bryant, mheule}@cs.cmu.edu

June 15, 2021

## Abstract

In 2006, Biere, Jussila, and Sinz made the key observation that the underlying logic behind algorithms for constructing Reduced, Ordered Binary Decision Diagrams (BDDs) can be encoded as steps in a proof in the *extended resolution* logical framework. Through this, a BDD-based Boolean satisfiability (SAT) solver can generate a checkable proof of unsatisfiability for a set of clauses. Such a proof indicates that the formula is truly unsatisfiable without requiring the user to trust the BDD package or the SAT solver built on top of it.

We extend their work to enable arbitrary existential quantification of the formula variables, a critical capability for BDD-based SAT solvers. We demonstrate the utility of this approach by applying a prototype solver to several problems that are very challenging for search-based SAT solvers, obtaining polynomially sized proofs on benchmarks for parity formulas, as well as the Urquhart, mutilated chessboard, and pigeonhole problems.

## 1 Introduction

When a Boolean satisfiability (SAT) solver returns a purported solution to a Boolean formula, its validity can easily be checked by making sure that the solution indeed satisfies the formula. When the formula is unsatisfiable, on the other hand, having the solver simply declare this to be the case requires the user to have faith in the solver, a complex piece of software that could well be flawed. Indeed, modern solvers employ a number of sophisticated techniques to reduce the search space. If one of those techniques is invalid or incorrectly implemented, the solver may overlook actual solutions and label a formula as unsatisfiable, even when it is not.

With SAT solvers providing the foundation for a number of different real-world tasks, this “false negative” outcome could have unacceptable consequences. For example, when used as part of a formal verification system, the usual strategy is to encode some undesired property of the system as a formula. The SAT solver is then used to determine whether some operation of the system could lead to this undesirable property. Having the solver declare the formula to be unsatisfiable is an indication that the undesirable behavior cannot occur, but only if the formula is truly unsatisfiable.

Rather than requiring users to place their trust in a complex software system, a *proof-generating* solver constructs a proof that the formula is unsatisfiable. The proof has a form that can readily be checked by a simple proof checker. Initial work of checking unsatisfiability results was based on resolution proofs, but modern checkers are based on stronger proof systems [23,45]. The checker provides an independent validation that the formula is indeed unsatisfiable. The checker can even be simple enough to be formally verified [15,30]. Such a capability has become an essential feature for modern SAT solvers.

In their 2006 papers [28, 38], Jussila, Sinz and Biere made the key observation that the underlying logic behind algorithms for constructing Reduced, Ordered Binary Decision Diagrams (BDDs) [6] can be encoded as steps in a proof in the *extended resolution* (ER) logical framework [40]. Through this, a BDD-based Boolean satisfiability solver can generate checkable proofs of unsatisfiability for a set of clauses. Such proofs indicate that the formula is truly unsatisfiable without requiring the user to trust the BDD package or the SAT solver built on top of it.

In this paper, we refine these ideas to enable a full-featured, BDD-based SAT solver. Chief among these is the ability to perform existential quantification on arbitrary variables. (Jussila, Sinz, and Biere [28] extended their original work [38] to allow existential quantification, but only for the root variable of a BDD.) In addition, we allow greater flexibility in the choice of variable ordering and the order in which conjunction and quantification operations are performed. This combination allows a wide range of strategies for creating a sequence of BDD operations that, starting with a set of input clauses, yield the BDD representation of the constant function  $\mathbf{0}$ , indicating that the formula is unsatisfiable. Using the extended-resolution proof framework, these operations can generate a proof showing that the original set of clauses logically implies the empty clause, providing a checkable proof that the formula is unsatisfiable.

As the experimental results demonstrate, our refinements enable a proof-generating BDD-based SAT solver to achieve polynomial performance on several classic “hard” problems [1, 13, 22, 42]. Since the performance of a proof-generating SAT solver affects not only the runtime of the program, but also the length of the proofs generated, achieving polynomial performance is an important step forward. We find that several of these problems can be efficiently solved using the *bucket elimination* strategy [18] employed by Jussila, Sinz, and Biere [28], but others require a novel approach inspired by symbolic model checking [11].

This paper assumes the reader has some background on BDDs and their algorithms. This background can be obtained from a variety of tutorial presentations [2, 7, 8]. The paper is largely self-contained regarding proof generation. The paper is structured as follows. First, it provides a brief introduction to the resolution and extended resolution logical frameworks and to BDDs. Then we show how a BDD-based SAT solver can generate proofs by augmenting algorithms for com-

putting the conjunction of two functions represented as BDDs, and for checking that one function logically implies another. We then describe our prototype implementation and evaluate its performance on several classic problems. We conclude with some general observations and suggestions for further work.

This paper is an extended version of an earlier conference paper [10]. Here we present more background material and more details about the proof-generation algorithms, as well as benchmark results on additional challenge problems.

## 2 Preliminaries

Given a Boolean formula over a set of variables  $\{x_1, x_2, \dots, x_n\}$ , a SAT solver attempts to find an assignment to these variables that will satisfy the formula, or it declares the formula to be unsatisfiable. As is standard practice, we use the term *literal* to refer to either a variable or its complement. Most SAT solvers use Boolean formulas expressed in *conjunctive normal form*, where the formula consists of a set of *clauses*, each consisting of a set of literals. Each clause is a disjunction: if an assignment sets any of its literals to true, the clause is considered to be satisfied. The overall formula is a conjunction: a satisfying assignment must satisfy all of the clauses.

We write  $\top$  to denote both tautology and logical truth. It arises when a clause contains both a variable and its complement. We write  $\perp$  to denote logical falsehood. It is represented by an empty clause.

We make use of the *if-then-else* operation, written *ITE*, defined as  $ITE(u, v, w) = (u \wedge v) \vee (\neg u \wedge w)$ .

When writing clauses, we omit disjunction symbols and use overlines to denote negation, writing  $\neg u \vee v \vee \neg w$  as  $\bar{u} v \bar{w}$ .

### 2.1 Resolution Proofs

Robinson [36] observed that the resolution inference rule formulated by Davis and Putnam [17] could form the basis for a refutation theorem-proving technique for first-order logic. Here, we consider its specialization to propositional logic. For clauses of the form  $C \vee x$ , and  $\bar{x} \vee D$ , the resolution rule derives the new clause  $C \vee D$ . This inference is written with a notation showing the required conditions above a horizontal line, and the resulting inference (known as the *resolvent*) below:

$$\frac{C \vee x \quad \bar{x} \vee D}{C \vee D}$$

Intuitively, the resolution rule is based on the property that implication is transitive. To see this, let proposition  $p$  denote  $\neg C$ , and proposition  $q$  denote  $D$ . Then  $C \vee x$  is equivalent to  $p \rightarrow x$ ,  $\bar{x} \vee D$  is equivalent to  $x \rightarrow D$ , and  $C \vee D$  is equivalent to  $p \rightarrow q$ . In other words, the resolution rule encodes the property that if  $p \rightarrow x$  and  $x \rightarrow q$ , then  $p \rightarrow q$ . As a special case, when  $C$  contains a literal  $l$  and  $D$  contains its complement  $\bar{l}$ , then the resolvent of  $C \vee x$  and  $D \vee \bar{x}$  will be a tautology.

Resolution provides a mechanism for proving that a set of clauses is unsatisfiable. Suppose the input consists of  $m$  clauses. A resolution proof is given as a *trace* consisting of a series of *steps*  $S$ ,

Table 1: General form of guarded implication and its special cases

Case	Notation	Formula	Clause
General	$u \xrightarrow{x} v$	$x \wedge u \rightarrow v$	$\bar{x} \bar{u} v$
Trivial prefix	$\top \xrightarrow{x} v$	$x \rightarrow v$	$\bar{x} v$
Invalid prefix	$\perp \xrightarrow{x} v$	$\top$	$\top$
Trivial suffix	$u \xrightarrow{x} \perp$	$\neg(x \wedge u)$	$\bar{x} \bar{u}$
Invalid suffix	$u \xrightarrow{x} \top$	$\top$	$\top$

where each step  $s_i$  consists of a clause  $C_i$  and a (possibly empty) list of antecedents  $A_i$ , where each antecedent is the index of one of the previous steps. The first set of steps, denoted  $S_m$ , consists of the input clauses without any antecedents. Each successive step then consists of a clause and a set of antecedents, such that the clause can be derived from the clauses in the antecedents by one or more resolution steps. It follows by transitivity that for each step  $s_i$ , with  $i > m$ , clause  $C_i$  is logically implied by the input clauses, written  $S_m \vdash C_i$ . If, through a series of steps, we can reach a step  $s_t$  where  $C_t$  is the empty clause, then the trace provides a proof that  $S_m \vdash \perp$ , i.e., the set of input clauses is not satisfiable.

For reasoning about the recursive steps of BDD operations, we have found it useful to introduce a notation we call a *guarded implication*, writing  $u \xrightarrow{x} v$  to denote the formula  $x \wedge u \rightarrow v$ . In clausal form, this is written as  $\bar{x} \bar{u} v$ . As is shown in Table 1, a number of special cases arise when one of the operands is either  $\top$  or  $\perp$ . In the table, we say a component is “invalid” if the resulting expression degenerates to a tautology. The “trivial” cases are ones for which the resulting clause contains just two literals.

One useful feature of the guarded implication notation is that it shows how chains of formulas involving guarded implication and regular implication can be linked via resolution steps. Suppose we have the combination  $a \rightarrow b$ ,  $b \xrightarrow{x} c$ , and  $c \rightarrow d$ . This can be written as  $a \rightarrow b \xrightarrow{x} c \rightarrow d$ . We can derive  $a \xrightarrow{x} d$  using the following resolution steps:

$$\frac{\frac{\bar{x} \bar{b} c \quad \bar{a} b}{\bar{x} \bar{a} c} \quad \bar{c} d}{\bar{x} \bar{a} d}$$

Observe that for each resolution step, the resolution variable is one of the intermediate variables in the chain of implications.

## 2.2 Extended Resolution

Grigori S. Tseitin [40] introduced the extended-resolution proof framework in a presentation at the Leningrad Seminar on Mathematical Logic in 1966. The key idea is to allow the addition of new *extension* variables to a resolution proof in a manner that preserves the integrity of the proof. In particular, in introducing variable  $e$ , there must be an accompanying set of clauses that encode

$e \leftrightarrow F$ , where  $F$  is a formula over variables (both original and extension) that were introduced earlier. These are referred to as the *defining clauses* for extension variable  $e$ . Variable  $e$  then provides a shorthand notation by which  $F$  can be referenced multiple times. Doing so can reduce the size of a clausal representation of a problem by an exponential factor.

An extension variable  $e$  is introduced into the proof by including its defining clauses in the list of clauses being generated. The proof checker must then ensure that the defining clauses obey the requirements for extension variables, as is discussed below. Thereafter, other clauses can include the extension variable or its complement, and they can list the defining clauses as antecedents.

Tseitin transformations are commonly used to encode a logic circuit or formula as a set of clauses without requiring the formulas to be “flattened” into a conjunctive normal form over the circuit inputs or formula variables. These introduced variables are called *Tseitin variables* and are considered to be part of the input formula. An extended resolution proof takes this concept one step further by introducing additional variables as part of the proof. The proof checker must ensure that these *extension* variables are used in a way that does not compromise the validity of the proof. Some problems for which the minimum resolution proof must be of exponential size can be expressed with polynomial-sized proofs in extended resolution [14].

## 2.3 Clausal Proofs

Checking an extended-resolution proof requires checking that the extension variables are used properly, in addition to checking that each new clause can be derived via resolution from its antecedent clauses. We use a *clausal proof system* to validate extended resolution proofs, because there are no tools designed specifically to fully check extended resolution proofs. In contrast, there are various fast and formally-verified checkers for clausal proofs [16, 30, 44]. When used to check an extended resolution proof, only some of the features of a clausal proof checker are required.

As with a resolution proof, a clausal proof is a sequence of clauses, but with special conditions imposed on the non-input clauses, i.e.,  $C_i$  for  $i > m$ . For  $i > m$ , define  $S_i$  inductively as  $S_i = S_{i-1} \cup \{C_i\}$ . The proof steps  $s_{m+1}, \dots, s_t$  represent a derivation from  $S_m$  to  $S_t$ . A clausal proof is a refutation if  $S_t$  contains the empty clause.

Step  $s_i$  in a proof is valid if the equisatisfiability<sup>1</sup> of  $S_{i-1}$  and  $S_i$  can be checked using a polynomially decidable redundancy property. For the case where  $C_i$  was obtained via resolution, we can simply check that the antecedents produce  $C_i$ . In case  $C_i$  is one of the defining clauses for some extension variable  $e$ , the checker must ensure that the clause is *blocked* [29]. That is, all possible resolvents of  $C_i$  with clauses in  $S_{i-1}$  that contain  $e$  must be tautologies. The blocked clause proof system is a generalization of extended resolution and allows the addition of blocked clauses that are blocked on non-extension variables. However, we do not use such capabilities in our proofs.

As an example of the use of extension variables, suppose we wish to introduce variable  $e$  as a shorthand for the formula  $\neg a \wedge b$ . The three defining clauses to encode  $e \leftrightarrow \neg a \wedge b$  are:

---

<sup>1</sup>Two Boolean formulas are *equisatisfiable* if they are either both satisfiable or both unsatisfiable.

ID	Formula	Clause
$D_1$	$e \rightarrow \neg a$	$\bar{e} \bar{a}$
$D_2$	$e \rightarrow b$	$\bar{e} b$
$D_3$	$\neg a \wedge b \rightarrow e$	$e a \bar{b}$

Using  $e$  as the resolution variable, clause  $D_1$  can be resolved with  $D_3$  to give clause  $\bar{a} a \bar{b} = \top$ . Likewise,  $D_2$  can be resolved with  $D_3$  to give clause  $b a \bar{b} = \top$ .

Clausal proofs also allow the removal of clauses. A proof can indicate that clause  $C_j$  can be removed after step  $s_i$  if it will not be used as an antecedent in any step  $s_k$  with  $k > i$ . With this restriction, clause deletion does not affect the integrity of the proof. As the experimental results of Section 4 demonstrate, deleting clauses that are no longer needed can substantially reduce the number of clauses the checker must track while processing a proof.

## 2.4 Binary Decision Diagrams

Reduced, Ordered Binary Decision Diagrams (which we refer to as simply “BDDs”) provide a canonical form for representing Boolean functions, and an associated set of algorithms for constructing them and testing their properties [6]. With BDDs, functions are defined over a set of variables  $X = \{x_1, x_2, \dots, x_n\}$ . We let  $L_0$  and  $L_1$  denote the two leaf nodes, representing the constant functions  $\mathbf{0}$  and  $\mathbf{1}$ , respectively.

Each nonterminal node  $u$  has an associated variable  $\text{Var}(u)$  and children  $\text{Hi}(u)$ , indicating the case where the node variable has value 1, and  $\text{Lo}(u)$ , indicating the case where the node variable has value 0.

Two lookup tables—the *unique table* and the *operation cache*—are critical for guaranteeing the canonicity of the BDDs and for ensuring polynomial performance of the BDD construction algorithms.

A node  $u$  is stored in a unique table, indexed by a key of the form  $\langle \text{Var}(u), \text{Hi}(u), \text{Lo}(u) \rangle$ , so that isomorphic nodes are never created. The nodes are shared across all of the BDDs [34]. In presenting algorithms, we assume a function  $\text{GETNODE}(\text{Var}(u), \text{Hi}(u), \text{Lo}(u))$  that checks the unique table and either returns the node stored there, or it creates a new node and enters it into the table. With this table, we can guarantee that the subgraphs with root nodes  $u$  and  $v$  represent the same Boolean function if and only if  $u = v$ . We can therefore uniquely identify Boolean functions with their BDD root nodes.

BDD packages support multiple operations for constructing and testing the properties of Boolean functions represented by BDDs. A number of these are based on the *Apply* algorithm [6]. Given a set of BDD roots  $u_1, u_2, \dots, u_k$  representing functions  $f_1, f_2, \dots, f_k$  respectively, and a Boolean OP, the algorithm generates the BDD representation  $w$  of the operation applied to those functions. For example, with  $k = 2$ , and  $\text{OP} = \text{AND}$ ,  $\text{APPLY}(\text{AND}, u_1, u_2)$  returns the root node for the BDD representation of  $f_1 \wedge f_2$ .

Figure 1 shows pseudo-code describing the overall structure of the Apply algorithm. The details for a specific operation are embodied in the functions  $\text{ISTERMINAL}$ ,  $\text{TERMINALVALUE}$ , and

```

APPLY(OP,  $u_1, \dots, u_k$ )
  if ISTERMAL(OP,  $u_1, \dots, u_k$ ):
    return TERMINALVALUE(OP,  $u_1, \dots, u_k$ )
   $K \leftarrow \langle \text{OP}, u_1, \dots, u_k \rangle$ 
  if  $K \in \text{Cache}$ :
    return  $\text{Cache}[K]$ 
   $w \leftarrow \text{APPLYRECUR}(\text{OP}, u_1, \dots, u_k)$ 
   $\text{Cache}[K] \leftarrow w$ 
  return  $w$ 

```

Figure 1: General structure of the Apply algorithm. The operation for a specific logical operation OP is determined by its terminal cases and its recursive structure.

APPLYRECUR. The first two of these detect terminal cases and what value to return when a terminal case is encountered. The third describes how to handle the general case, where the arguments must be expanded recursively. The algorithm makes use of *memoizing*, where previously computed results are stored in an operation cache, indexed by a key consisting of the operands [33]. Whenever possible, results are retrieved from this cache, avoiding the need to perform redundant calls to APPLYRECUR. With this cache, the worst case number of recursive steps required by the algorithm is bounded by the product of the sizes (in nodes) of the arguments.

### 3 Proof Generation During BDD Construction

In our formulation, every newly created BDD node  $u$  is assigned an extension variable. (As notation, we use the same name for the node and for its extension variable.) We then extend the Apply algorithm to generate proofs based on the recursive structure of the BDD operations.

Let  $S_m$  denote the set of input clauses. Our goal is to generate a proof that  $S_m \vdash \perp$ , i.e., there is no satisfying assignment for these clauses. Our BDD-based approach generates a sequence of BDDs with root nodes  $u_1, u_2, \dots, u_t$ , where  $u_t = L_0$ , based on a combination of the following operations. (The exact sequencing of operations is determined by the *evaluation mechanism*, as is described in Section 4.)

1. For input clause  $C_i$  generate its BDD representation  $u_i$  using a series of Apply operations to perform disjunctions.
2. For roots  $u_j$  and  $u_k$ , generate the BDD representation of their conjunction  $u_l = u_j \wedge u_k$  using the Apply operation to perform conjunction.
3. For root  $u_j$  and some set of variables  $Y \subseteq X$ , perform existential quantification:  $u_k = \exists Y u_j$ .

Although the existential quantification operation is not mandatory for a BDD-based SAT solver, it can greatly improve its performance [19]. It is the BDD counterpart to Davis-Putnam variable

elimination on clauses [17]. As the notation indicates, there are often multiple variables that can be eliminated simultaneously. Although the operation can cause a BDD to increase in size, it generally causes a reduction. Our experimental results demonstrate the importance of this operation.

As these operations proceed, we simultaneously generate a set of proof steps. The details of each step are given later in the presentation. For each BDD generated, we maintain the proof invariant that its root node  $u_j$  satisfies  $S_m \vdash u_j$ .

1. Following the generation of the BDD  $u_i$  for input clause  $C_i$ , we also generate a proof that  $C_i \vdash u_i$ . This is described in Section 3.1.
2. Justifying the results of conjunctions requires two parts:
  - (a) Using a modified version of the Apply algorithm for conjunction we follow the structure of its recursive calls to generate a proof that the algorithm preserves implication:  $u_j \wedge u_k \rightarrow u_l$ . This is described in Section 3.2.
  - (b) This implication can be combined with the earlier proofs that  $S_m \vdash u_j$  and  $S_m \vdash u_k$  to prove  $S_m \vdash u_l$ .
3. Justifying the quantification also requires two parts:
  - (a) Following the generation of  $u_k$  via existential quantification, we perform a separate check that  $u_j \rightarrow u_k$ . This check uses a proof-generating version of the Apply algorithm for implication checking. This is described in Section 3.3.
  - (b) This implication can be combined with the earlier proof that  $S_m \vdash u_j$  to prove  $S_m \vdash u_k$ .

Compared to the prior work by Sinz and Biere [38], our key refinement is to handle arbitrary existential quantification operations. (When implementing a SAT solver, these quantifications must be applied in restricted ways [43], but since proofs of unsatisfiability only require proving implication, we need not be concerned with the details of these restrictions.) Rather than attempting to track the detailed logic underlying the quantification operation, we run a separate check that implication is preserved. As is the case with many BDD packages, our implementation can perform existential quantification of an arbitrary set of variables in a single pass over the argument BDD. We only need to perform a single implication check for the entire quantification.

Sinz and Biere’s construction assumed there were special extension variables  $n_1$  and  $n_0$  to represent the BDD leaves  $L_1$  and  $L_0$ . Their proofs then includes unit clauses  $n_1$  and  $\bar{n}_0$  to force these variables to be set to 1 and 0, respectively. This formulation greatly reduces the number of special cases to consider in the proof-generating version of the Apply algorithm, but it complicates the generation of proofs for the implication check. Instead, we directly associate leaves  $L_1$  and  $L_0$  with  $\top$  and  $\perp$ .

The  $n$  variables in the input clauses all have associated BDD variables. The proof then introduces an extension variable every time a new BDD node is created. In the following presentation, we use the node name (e.g.,  $u$ ) to indicate the associated extension variable. In the actual implementation, the extension variable (an integer) is stored as one of the fields in the node representation.



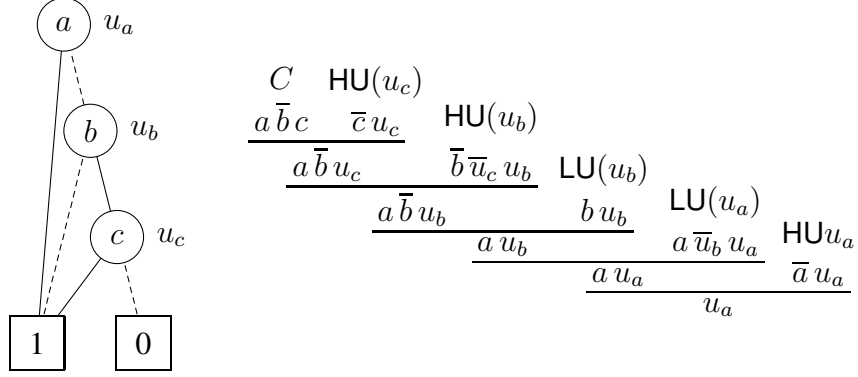

Figure 2: BDD representation of clause  $C = a\bar{b}c$  and its resolution proof

When creating a new node, the `GETNODE` function adds (up to) four defining clauses for the associated extension variable. For node  $u$  with variable  $\text{Var}(u) = x$ ,  $\text{Hi}(u) = u_1$ , and  $\text{Lo}(u) = u_0$ , the clauses are:

Notation	Formula	Clause
$\text{HD}(u)$	$u \xrightarrow{x} u_1$	$\bar{x}\bar{u}u_1$
$\text{LD}(u)$	$u \xrightarrow{\bar{x}} u_0$	$x\bar{u}u_0$
$\text{HU}(u)$	$u_1 \xrightarrow{x} u$	$\bar{x}\bar{u}_1u$
$\text{LU}(u)$	$u_0 \xrightarrow{\bar{x}} u$	$x\bar{u}_0u$

The names for these clauses combines an indication of whether they correspond to variable  $x$  being 1 (H) or 0 (L) and whether they form an implication from the node down to its child (D) or from the child up to its parent (U). As Table 1 indicates, some of these clauses can degenerate to a tautology when one of the children is a leaf node. Such clauses are omitted from the proof. Each clause is numbered according to its step number in the trace. These defining clauses encode the assertion:

$$u \leftrightarrow \text{ITE}(x, u_1, u_0)$$

thus satisfying Tseitin's restriction on the use of extension variables.

### 3.1 Generating BDD Representations of Clauses

The BDD representation for a clause  $C$  has a simple, linear structure, from which it is easy to generate a resolution proof that the root node  $u$  of its BDD representation satisfies  $C \vdash u$ . The general algorithm is described by Sinz and Biere [38]. Here we illustrate the idea via an example.

Figure 2 shows the BDD representation of clause  $C = a\bar{b}c$ . As can be seen, the BDD for a clause has a very specific structure. For each literal in the clause, there is a node labeled by the variable, with one child being leaf  $L_1$  and the other being either the node for the next literal in the variable ordering or leaf  $L_0$ . The righthand side of Figure 2 shows a resolution proof of  $C \vdash u_a$ , where  $u_a$  is the root node of the BDD. The proof uses the antecedents  $\text{HU}(u)$  and  $\text{LU}(u)$

Terminal Cases	
Condition	Result
$u = v$	$(u, \top)$
$u = L_0$	$(L_0, \top)$
$v = L_0$	$(L_0, \top)$
$u = L_1$	$(v, \top)$
$v = L_1$	$(u, \top)$

```

APPLYRECUR(AND, u, v)
  J ← {}
  x ← min(Var(u), Var(v))
  if x = Var(u):
    u1, u0 ← Hi(u), Lo(u)
    J ← J ∪ {HD(u), LD(u)}
  else:
    u1, u0 ← u, u
  if x = Var(v):
    v1, v0 ← Hi(v), Lo(v)
    J ← J ∪ {HD(v), LD(v)}
  else:
    v1, v0 ← v, v
  w1, s1 ← APPLY(AND, u1, v1)
  w0, s0 ← APPLY(AND, u0, v0)
  J ← J ∪ {s1, s0}
  if w1 = w0:
    w ← w1
  else:
    w ← GETNODE(x, w1, w0)
    J ← J ∪ {HU(w), LU(w)}
  s ← JUSTIFYAND(⟨u, v, w⟩, J)
  return (w, s)

```

Figure 3: Terminal cases and recursive step of the Apply operation for conjunction, modified for proof generation. Each call returns both a node and a proof step.

for each node  $u$  in the BDD (except for the tautological case representing the final edge to  $L_0$ .) The resolution steps transform the initial clause into a unit clause consisting of the extension variable for the root node in the BDD representation of the clause. They do so by applying the defining clauses from the bottom node up to the top. In the example, the one upward defining clause for node  $u_c$  transforms  $a\bar{b}c$  into  $a\bar{b}u_c$ . The two for node  $u_b$  transform this into  $au_b$ , and the defining clauses for node  $u_a$  transform this to  $u_a$ . The order in which the two defining clauses are used in the resolution depends on whether the literal is positive or negative in the clause. With each pair of resolution steps, one of the literals from the original clause is eliminated.

The proof checker we use can handle multi-step resolution proofs with linear structures (i.e., each proof step has at least one of the antecedents as its input), such as that shown in Figure 2b. Therefore, we can generate a single proof step for  $C_i \vdash u_i$  with  $u_i$  as the clause, and a list of antecedents consisting of clause identifier  $i$ , along with the relevant defining clauses for the nodes in the BDD representation of the clause.

## 3.2 Performing Conjunctions

The key idea in generating proofs for the conjunction operation is to follow the recursive structure of the Apply algorithm. We do this by integrating proof generation into the Apply procedures,

Term	Formula	Clause
UHD	$u \xrightarrow{x} u_1$	$\bar{x} \bar{u} u_1$
VHD	$v \xrightarrow{x} v_1$	$\bar{x} \bar{v} v_1$
ULD	$u \xrightarrow{\bar{x}} u_0$	$x \bar{u} u_0$
VLD	$v \xrightarrow{\bar{x}} v_0$	$x \bar{v} v_0$
WHU	$w_1 \xrightarrow{x} w$	$\bar{x} \bar{w}_1 w$
WLU	$w_0 \xrightarrow{\bar{x}} w$	$x \bar{w}_0 w$
ANDH	$u_1 \wedge v_1 \rightarrow w_1$	$\bar{u}_1 \bar{v}_1 w_1$
ANDL	$u_0 \wedge v_0 \rightarrow w_0$	$\bar{u}_0 \bar{v}_0 w_0$

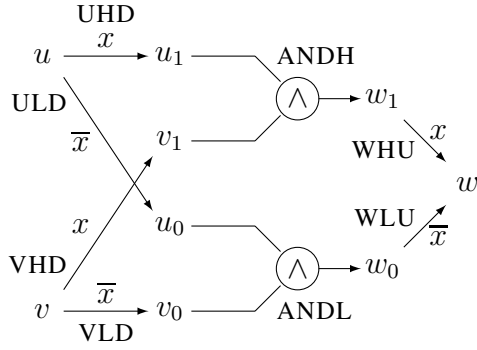

Figure 4: Clause structure for general step of the APPLY algorithm for conjunction operations

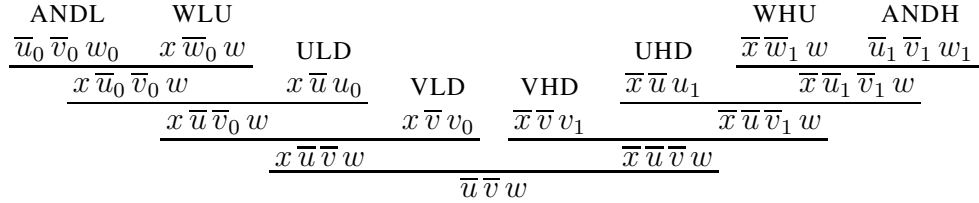

Figure 5: Resolution proof for general step of the conjunction operation

as is shown in Figure 3. This follows the standard form of the APPLY algorithm (Figure 1), with the novel feature that each result includes both a BDD node  $w$  and a proof step number  $s$ . For arguments  $u$  and  $v$ , step  $s$  lists clause  $\bar{u} \bar{u} w$  along with antecedents defining a resolution proof of the implication  $u \wedge v \rightarrow w$ .

As the table of terminal cases show, these cases all correspond to tautologies. For example, the case of  $u = L_1$ , giving  $w = v$  is justified by that tautology  $\top \wedge v \rightarrow v$ . Failing a terminal or previously computed case, the function must recurse, branching on the variable  $x$  that is the minimum of the two root variables. The procedure accumulates a set of steps  $J$  to be used in the implication proof. These include the two steps (possibly tautologies) from the two recursive calls. At the end, it invokes a function JUSTIFYAND to generate the required proof. In returning the pair  $(w, s)$ , this value will be stored in the operation cache and returned as the result of the Apply operation.

### 3.2.1 Proof Generation for the General Case

A proof generated by APPLY with operation AND inducts on the structure of the argument and result BDDs. That is, it assumes that the results  $w_1$  and  $w_0$  of the recursive calls to arguments  $u_1$  and  $v_1$  and to  $u_0$  and  $v_0$  satisfy the implications  $u_1 \wedge v_1 \rightarrow w_1$  and  $u_0 \wedge v_0 \rightarrow w_0$ , and that these calls generated proof steps  $s_1$  and  $s_0$  justifying these implications. For the general case, where none of the equalities hold and the recursive calls do not yield tautologies, the form of the proof

is based on the structure shown in Figure 4. That is the set  $J$  contains references to eight steps having clauses consisting of downward defining clauses from the arguments (UHD, VHD, ULD, and VLD), implications for the two recursive calls (ANDH and ANDL), and upward defining clauses for the result (WHU and WLU). This diagram uses labeled lines to indicate guarded implications, and the two-input, one-output operator labeled with  $\wedge$  to indicate the implication properties for the two recursive calls.

These clauses are used in the resolution proof shown in Figure 5. The resolutions generally follow the structure shown in Figure 4, where a variable that forms the head of one clause arrow and the tail of another serves as the resolution variable for the two clauses, much as we saw with guarded implications. In addition, the two arrows converging at the result node  $w$  have complementary literals  $x$  and  $\bar{x}$  as guards, indicating another resolution step. For this general case, there are multiple possible orderings for the resolution steps along the left-hand and right-hand sides of the proof. We chose a particular ordering that helps with some of the special cases. Along the left, this involves first resolving clause ANDL and WLU, then resolving the result first with clause ULD and then clause VLD. A similar progression occurs along the right. As this figure illustrates, a total of seven resolution steps are required, although these can merged into two linear resolution chains.

### 3.2.2 Proof Generation for Special Cases

The proof structure shown in Figure 5 only holds for the most general form of the recursion. However, there are many special cases, such as when the recursive calls yield tautologous results, when some of the child nodes are equal, and when the two recursive calls return the same node. Figure 6 illustrates six of these special cases, but there are many more. As these figures show, the proof structures can be very different from the general case. Not only must any tautologous implications be pruned away, there are some cases where other clauses become extraneous.

Our method for handling both the general and special cases relies on the V-shaped structure of the proofs, as is illustrated in Figure 5. That is, there are two linear chains, one along the left and one along the right consisting of some subsequence of the following clauses:

$$A_L = \text{ANDL, WLU, ULD, VLD} \quad (1)$$

$$A_H = \text{ANDH, WHU, UHD, VHD} \quad (2)$$

These will be proper subsequences when some of the clauses are not included in the set  $J$  (Figure 3), or they are tautologies. Through analysis and experiment, we determined that, of the 32 possible subsequences of the five clauses, 13 of them can actually occur. Of these, 9 yield a fixed strategy for choosing which clauses should be used in generating a proof for that chain, while 4 each have two possible outcomes.

Figure 7 shows code that handles all of the cases for a chain. Function RESOLVECHAIN is called with an ordered sequence of clauses  $D_1, \dots, D_k$ . Starting with the first clause, it attempts to resolve each successive clause, skipping those that do not satisfy the resolution property. If any resolution steps occur, then the result is the unique clause required to complete the proof. If there are no resolutions, then the function returns the set of all clauses provided. One of these is guaranteed to suffice for the final resolution step. The function is called for both of the chains formed

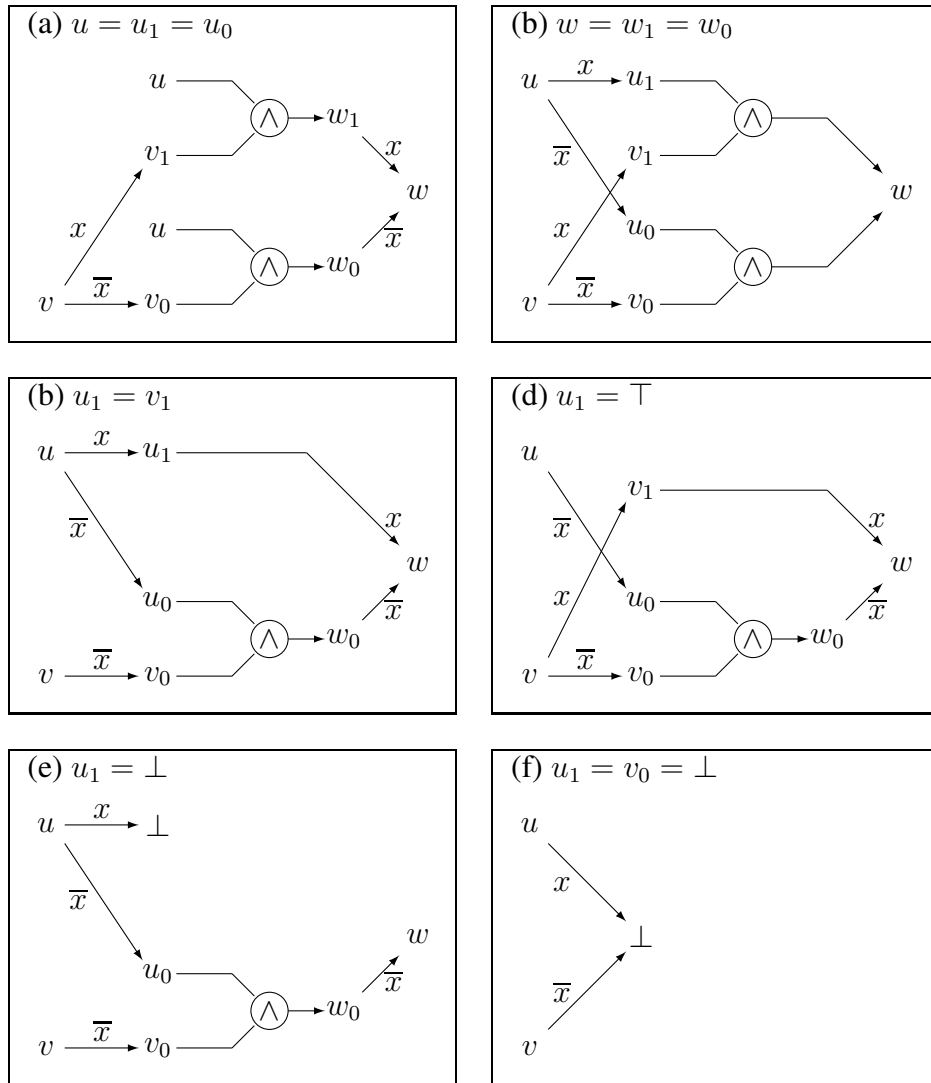

Figure 6: Special cases of clause structure for the conjunction operation

```

RESOLVECHAIN( $[D_1, D_2, \dots, D_k]$ )
   $C \leftarrow D_1$ 
  for  $i = 2, \dots, k$ :
    if RESOLVABLE( $C, D_i$ ):
       $C \leftarrow$  RESOLVE( $C, D_i$ )
  if  $C \neq D_1$ :
    /* Resolution sequence generated */
    return  $\{C\}$ 
    /* Calling program must test single resolution steps */
  else return  $\{D_1, D_2, \dots, D_k\}$ 

```

Figure 7: Generating resolution proof for linear chain, handling both general and special cases

as subsequences of  $A_H$  and  $A_L$ . The final resolution step is found by trying all possible pairs of clauses generated by the two calls. Of course, the function also needs to keep track of identities of the clauses used in function RESOLVECHAIN in order to generate the list of antecedents for the resolution proof.

Most of the calls to RESOLVECHAIN yield a unique clause, based on one or more resolution steps. For example, the general case (Figure 4) as well as four of the special cases illustrated (Figure 6a–d) are handled in this manner. The second outcome for the function—where it returns the set of all clauses in the chain—only occurs when there are at most two clauses in the chain, and so choosing among them can simply be done by trial and error. These occur, for example for the last two illustrated cases (Figure 6e–f). Considering the righthand chain for these cases, clauses UHD and VHD will both be non-tautological, but only UHD is required for the proof. Our experiments indicate that the need for enumerating pairs does not happen very often—well under 10% of the cases—and so it incurs negligible cost.

### 3.3 Checking Implication

As described in Section 3, we need not track the detailed logic of the algorithm that performs existential quantification. Instead, when the quantification operation applied to node  $u$  generates node  $v$ , we generate a proof of implication afterwards, using the APPLY algorithm adapted for implication checking, as shown in Figure 8. A failure of this implication check would indicate an error in the BDD package, and so its only purpose is to generate a proof that the implication holds, signaling a fatal error if the implication does not hold.

This particular operation does not generate any new nodes, and so its returned result is simply a proof step number. The (successful) terminal cases correspond to the tautological cases  $u \rightarrow u$ ,  $\perp \rightarrow v$ , and  $u \rightarrow \top$ .

Each recursive step accumulates up to six proof steps as the set  $J$  to be used in the implication proof. Figure 9 shows the structure of these clauses for the general case where neither equality holds, and neither recursive call returns  $\top$ . The clauses consist of the two downward defining

Terminal Cases	
Condition	Result
$u = v$	$\top$
$u = L_0$	$\top$
$v = L_1$	$\top$
$u = L_1, v \neq L_1$	Error
$v = L_0, u \neq L_0$	Error

```

APPLYRECUR(IMPLY, u, v)
  J ← {}
  x ← min(Var(u), Var(v))
  if x = Var(u):
    u1, u0 ← Hi(u), Lo(u)
    J ← J ∪ {HD(u), LD(u)}
  else:
    u1, u0 ← u, u
  if x = Var(v):
    v1, v0 ← Hi(v), Lo(v)
    J ← J ∪ {HU(v), LV(v)}
  else:
    v1, v0 ← v, v
  s1 ← APPLY(IMPLY, u1, v1)
  s0 ← APPLY(IMPLY, u0, v0)
  J ← J ∪ {s1, s0}
  s ← JUSTIFYIMPLICATION((u, v), J)
  return s

```

Figure 8: Terminal cases and recursive step of the Apply algorithm for implication checking

Term	Formula	Clause
UHD	$u \xrightarrow{x} u_1$	$\bar{x} \bar{u} u_1$
ULD	$u \xrightarrow{\bar{x}} u_0$	$x \bar{u} u_0$
IMH	$u_1 \rightarrow v_1$	$\bar{u}_1 v_1$
IML	$u_0 \rightarrow v_0$	$\bar{u}_0 v_0$
VHU	$v_1 \xrightarrow{x} v$	$\bar{x} \bar{v}_1 v$
VLU	$v_0 \xrightarrow{\bar{x}} v$	$x \bar{v}_0 v$

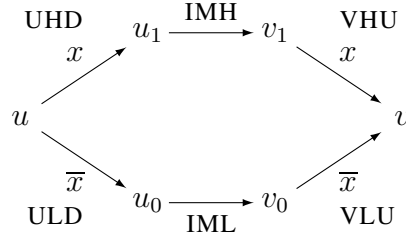

Figure 9: Clause structure for general step of implication checking

$$\frac{\frac{\frac{\text{IML}}{\bar{u}_0 v_0} \quad \frac{\text{ULD}}{x \bar{u} u_0}}{x \bar{u} v_0} \quad \frac{\text{VLU}}{x \bar{v}_0 v}}{x \bar{u} v} \quad \frac{\frac{\text{VHU}}{\bar{x} \bar{v}_1 v} \quad \frac{\text{UHD}}{\bar{x} \bar{u} u_1} \quad \frac{\text{IMH}}{\bar{u}_1 v_1}}{\bar{x} \bar{u} v_1}}{\bar{x} \bar{u} v}}{\bar{u} v}$$

Figure 10: Resolution proof for general step of the implication checking operation

clauses for argument  $u$ , labeled UHD and ULD, the clauses returned by the recursive calls, labeled IMH and IML, and the two upward defining clauses for argument  $v$ , labeled VHU and VLU.

Figure 10 shows the resulting resolution proof. Overall, we can see that both the clause structure and the proof are slightly simpler versions of those for the conjunction operation. Once again there can be many special cases yielding different clause structures and requiring different resolution proofs. But, the same chain resolution (Figure 7) strategy can be used, with the following sequences of clauses:

$$\begin{aligned} I_H &= \text{IMH, UHD, VHU} \\ I_L &= \text{IML, ULD, VLU} \end{aligned}$$

Of the eight possible subsets of three clauses, six of these can actually occur. Five of the six then yield a fixed strategy, while one can either be handled by resolution, or it will generate two possible choices.

## 4 Experimental Results

We implemented a prototype proof-generating, BDD-based SAT solver entirely in Python that we call “PGBDD” (for Proof-Generating BDD). The complete program consists of around 2130 lines of code, including a BDD package, support for generating extended-resolution proofs, and the overall SAT solver framework.<sup>2</sup> Although slow, it can handle large enough benchmarks to provide some useful insights into the potential for a BDD-based SAT solver to generate proofs of challenging problems, especially when quantification is supported. It generates proof in the LRAT format [15].

Extending a BDD package to support proof generation is surprisingly straightforward. Each node is extended with five fields: one for numeric value of its extension variable and four for the step numbers of its defining clauses. For conjunction operations, the operation cache stores both the result node and the identifier of the justifying clause. For an implication-checking operation, it stores only the identifier of the justifying clause.

Our BDD package supports mark-and-sweep garbage collection. It starts the marking using the root nodes for all active terms in the sequence of root nodes  $u_1, u_2, \dots$ . Following the marking phase, it traverses the unique table and eliminates the unmarked nodes. It also traverses the operation caches and eliminates any entries for which one of the argument nodes or the result node is unmarked. We have found that garbage collection greatly reduces the number of nodes the package must maintain. It can force the subsequent regeneration of some nodes, but well under 10% of the total. When a node is deleted, the solver can also direct the proof checker to delete its defining clauses. Similarly, when an entry is deleted from the operation cache, the solver can direct the proof checker to delete those clauses added while generating the justification for the entry. Our experimental results show that a checker need not track more than 5% of the total clauses generated.

---

<sup>2</sup>The solver, along with code for generating and testing a set of benchmarks, is available at <https://github.com/rebryant/pgbdd-artifact>.



In addition to the input CNF file, the program can accept a variable-ordering file, mapping the input variables in the CNF to their levels in the BDD. This ordering must be a permutation.

The solver supports three different evaluation mechanisms:

**Linear:** Form the conjunction of the clauses, according to their order in the input file. No quantification is performed. This matches the operation described for the original version of EBDDRES [38].

**Bucket Elimination:** Place the BDDs representing the clauses into buckets according to the levels of their topmost variables. Then process the buckets from lowest to highest. While a bucket has more than one element, repeatedly remove two elements, form their conjunction, and place the result in the bucket designated by the topmost variable. Once the bucket has a single element, existentially quantify the topmost variable and place the result in the appropriate bucket [18]. This matches the operation described for the revised version of EBDDRES [28].

**Scheduled:** Perform operations as specified by a *scheduling* file, as described below.

The scheduling file contains a sequence of lines, each providing a command in a simple, stack-based notation:

$\subset c_1, \dots, c_k$	Push the BDD representations of the specified clauses onto the stack
$\text{a } m$	Replace the top $m$ elements on the stack with their conjunction
$\text{q } v_1, \dots, v_k$	Replace the top element of the stack with its quantification by the specified variables

In generating benchmarks, we wrote programs to generate the CNF files, the variable orderings, and the schedules in a unified framework.

For all of our benchmarks we report the total number of clauses in the proof, including the input clauses, the defining clauses for the extension variables (up to four per BDD node generated) and the derived clauses (one per input clause and up to two per result inserted into the operation cache.)

We compare the performance of PGBDD to that of KISSAT, the winner of the 2020 SAT competition [5]. KISSAT represents the state of the art in search-based SAT solvers. KISSAT was configured to abort once the proof being generated exceeded 200 million clauses.

## 4.1 Reordered Parity Formulas

Chew and Heule [13] introduced a benchmark based on computing the parity of a set of Boolean values  $x_1, \dots, x_n$  using two different orderings of the inputs, and with one of the variables negated in the second computation:

$$\begin{aligned} \text{Parity}A(x_1, \dots, x_n) &= x_1 \oplus x_2 \oplus \dots \oplus x_n \\ \text{Parity}B(x_1, \dots, x_n) &= [p_1 \oplus x_{\pi(1)}] \oplus [p_2 \oplus x_{\pi(2)}] \oplus \dots \oplus [p_n \oplus x_{\pi(n)}] \end{aligned}$$

where  $\pi$  is a random permutation, and each  $p_i$  is either 0 or 1, with the restriction that  $p_i = 1$  for only one value of  $i$ . The two sums associate from left to right. The formula  $\text{Parity}A \wedge \text{Parity}B$

## Parity Clauses

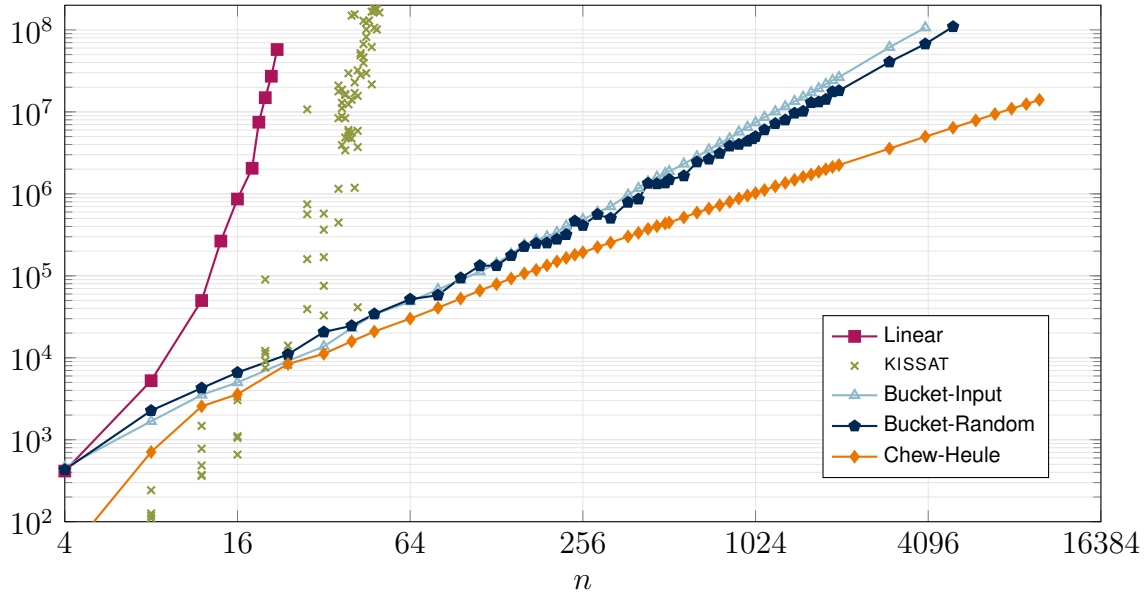

Figure 11: Total number of clauses in proofs of reordered parity encodings with  $n$  leaves. With quantification, the count grows as  $n^{1.68}$ , although it cannot match the  $O(n \log n)$  performance of Chew and Heule.

is therefore unsatisfiable, but the permutation makes this difficult for search-based SAT solvers to determine. The CNF has a total of  $3n - 2$  variables— $n$  values of  $x_i$ , plus the Tseitin variables encoding the intermediate terms in the two expressions.

Chew and Heule experimented with the search-based solver CADICAL [3] and found it could not handle cases with  $n$  greater than 50. They devised a specialized method for directly generating proofs in the DRAT proof system, obtaining proofs that scale as  $O(n \log n)$  and gave results for up to  $n = 4,000$ . They also tried EBDDRES, but only in its default mode, where it performs only linear evaluation without any quantification.

Figure 11 shows the result of applying both PGBDD and KISSAT to this problem. Note that the graph is a log-log plot, and so the values are highly compressed along both dimensions. Using linear evaluation, the program has exponential performance. It generates a proof with over 57 million clauses for  $n = 22$ . Using KISSAT, we found the results were very sensitive to the choice of random permutation, and so we show results using five different random seeds for each value of  $n$ . We were able to generate proofs for instances with  $n$  up to 50, but we also encountered cases where the proofs exceeded the limit of 200 million clauses starting with  $n = 40$ . We can see that KISSAT does better than linear evaluation with PGBDD, but both are exponential in  $n$ .

Using bucket elimination, on the other hand, yields polynomial performance, as is shown in the log-log plot of Figure 11. We tried a number of strategies for ordering the variables. Interestingly, we found the best performance was achieved by randomly permuting the variables, although this strategy only yielded a constant factor improvement over simply using the ordering from the CNF

file. As the graphs show, we were able to handle cases with  $n$  up to 5,000, generating a proof with around 109 million clauses. The overall growth trend is around  $n^{1.68}$ .

Included in the graph are results for running Chew and Heule’s proof generator on this program. As can be seen, the performance of PGBDD is comparable to theirs up to around  $n = 64$ . From there on, however, the benefit of their  $O(n \log n)$  algorithm becomes apparent. Even for  $n = 10,000$ , their proof contains less than 11 million clauses. Of course, their construction relies on particular properties of the underlying problem, while ours was generated by a general-purpose SAT solver.

## 4.2 Urquhart Formulas

Urquhart [42] introduced a family of formulas that require resolution proofs of exponential size. Over the years, two classes of SAT benchmarks have been labeled as “Urquhart Problems” [12,31]. These are considered to be difficult challenge problems for SAT solvers. Here we define their general form, describe their differences, and evaluate the performance of both KISSAT and PGBDD on both classes.

Urquhart’s construction is based on a class of bipartite graphs with special properties. Define  $G_k$  as the set of undirected graphs with each graph satisfying the following properties:

- It is *bipartite*: The set of vertices can be partitioned into sets  $L$  and  $R$ , such that the edges  $E$  satisfy  $E \subseteq L \times R$ .
- It is *balanced*:  $|L| = |R|$ .
- It has bounded degree: No vertex has more than  $k$  incident edges.

Furthermore, the graphs must be *expanders*, defined as follows [27]. For a subset of vertices  $U \subseteq L$ , define  $R(U)$  to be those vertices in  $R$  adjacent to the vertices on  $U$ . A graph in  $G_k$  is an expander if there is some constant  $d > 0$ , such that for any  $U \subseteq L$  with  $|U| \leq |L|/2$ , the set  $R(U)$  satisfies  $|R(U)| \geq (d + 1)|U|$ . Urquhart considers expander graphs with degree bound  $k = 5$  and that are parameterized by a size value  $m$  with  $|L| = |R| = m^2$ .

To transform such a graph into a formula, each edge  $(i, j) \in E$  has an associated variable  $x_{\{i,j\}}$ . (We use this notation to emphasize that the order of the indices does not matter.) Each vertex is assigned a polarity  $p_i \in \{0, 1\}$ , such that the sum of the polarities is odd. The clauses then encode the formula:

$$\sum_{i=1}^{2m^2} \left[ \sum_{(i,j) \in E} x_{\{i,j\}} + p_i \right] \equiv 0 \pmod{2}$$

This is false of course, since each edge gets counted twice in the sum, and the sum of the polarities is odd.

The two families of benchmarks differ in how the expander graphs are constructed. Li’s benchmarks are based on the explicit construction of expander graphs due to Margulis [20, 32] that is cited by Urquhart. Thus, his graphs are fully defined by the size parameter  $m$ . Simon’s benchmarks are based on randomly generated graphs, and thus they are characterized by both the size

## Urquhart Clauses

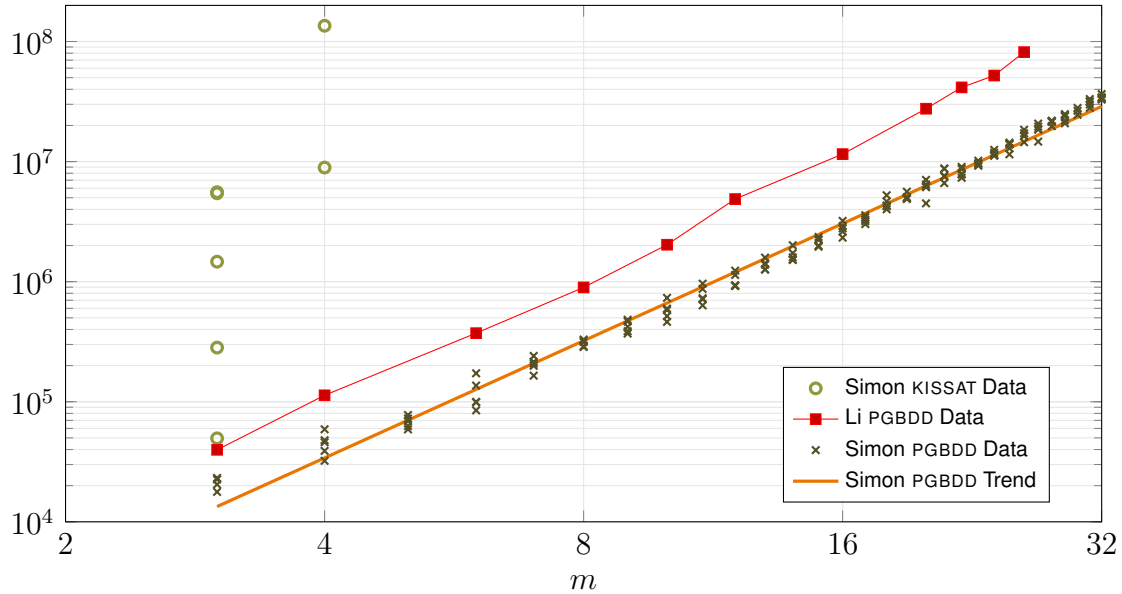

Figure 12: Total number of clauses in proofs of two classes of Urquhart formulas. KISSAT scales exponentially, but using BDDs with bucket elimination gives scalings of  $m^{3.48}$  (Li) and  $m^{3.24}$  (Simon).

parameter  $m$  and the initial random seed  $s$ . Although random graphs satisfy the expander condition with high probability [27], it is unclear whether the particular instances generated by Simon’s benchmark generator are truly expander graphs. The widely used SAT benchmarks with names of the form `UrqM_S.cnf` were generated by Simon’s program for size parameter  $m = M$  and initial seed  $S$ . For Simon’s benchmarks, we generated five different formulas for each value of  $m$ , using random seeds 1–5.

Figure 12 shows data for running KISSAT, as well as PGBDD using bucket elimination. The data for KISSAT demonstrates how difficult these benchmark problems are for search-based SAT solvers. Setting an upper limit of 200 million clauses in the proof, we found that KISSAT could handle all five instances of Simon’s benchmarks with  $m = 3$  (with proofs ranging from 49,585 to 5,565,509 clauses), two of the five for  $m = 4$  (with 8,922,685 and 135,352,697 clauses), and none for larger values of  $m$ . For Li’s benchmark it failed for even the minimum case of  $m = 3$ . Running PGBDD with bucket elimination fares much better. For Li’s benchmarks, it successfully handled instances up to  $m = 26$ , yielding an overall polynomial trend of  $m^{3.48}$  clauses. For Simon’s benchmarks, bucket elimination handled benchmarks for all five seeds up to  $m = 32$ , having an overall polynomial trend of  $m^{3.24}$ .

Observe that Simon’s benchmarks are decidedly easier than Li’s, requiring up to an order of magnitude fewer clauses in the proofs. In our attempts to use linear evaluation, our program failed any Li benchmark. For Simon’s, it could handle all five cases with  $m = 3$ , but none beyond that. Once again, we see that linear evaluation cannot match the performance of a state-of-the-art

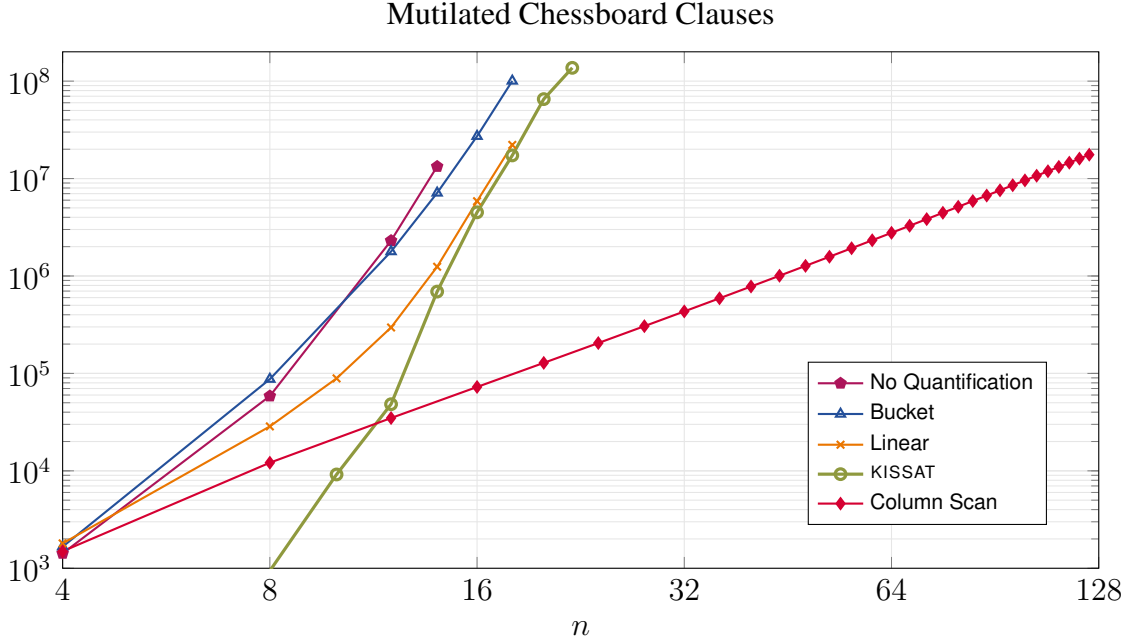

Figure 13: Total number of clauses in proofs of  $n \times n$  mutilated chess boards. The proofs using the column scanning approach grow as  $n^{2.7}$ .

search-based SAT solver, but the use of quantification can lead to polynomial performance.

Jussila, Sinz, and Biere [28] showed benchmark results for what appear to be Simon’s Urquhart formulas up to  $m = 8$  with performance comparable to ours. Indeed, in using bucket elimination, we are replicating their approach. We know of no other proof-generating SAT solver that can handle Urquhart formulas of this scale.

### 4.3 Mutilated Chessboard

The mutilated chessboard problem considers an  $n \times n$  chessboard, with the corners on the upper left and the lower right removed. It attempts to tile the board with dominos, with each domino covering two squares. Since the two removed squares had the same color, and each domino covers one white and one black square, no tiling is possible. This problem has been well studied in the context of resolution proofs, for which it can be shown that any proof must be of exponential size [1].

A standard CNF encoding involves defining Boolean variables to represent the boundaries between adjacent squares, set to 1 when a domino spans the two squares, and set to 0 otherwise. The clauses then encode an Exactly1 constraint for each square, requiring each square to share a domino with exactly one of its neighbors. We label the variables representing a horizontal boundary between a square and the one below as  $y_{i,j}$ , with  $1 \leq i < n$  and  $1 \leq j \leq n$ . The variables representing the vertical boundaries are labeled  $x_{i,j}$ , with  $1 \leq i \leq n$  and  $1 \leq j < n$ . With a mutilated chessboard, we have  $y_{1,1} = x_{1,1} = y_{n-1,n} = x_{n,n-1} = 0$ .

As the log-log plot in Figure 13 shows, a straightforward application of linear conjunctions or bucket elimination also leads to exponential performance by PGBDD. Indeed, KISSAT outperforms PGBDD when operating in these modes, but it still has exponential performance.

On the other hand, another approach, inspired by symbolic model checking [11] yields polynomial performance. It is based on the following observation: when processing the columns from left to right, the only information required to place dominos in column  $j$  is the identity of those rows  $i$  for which a domino crosses horizontally from  $j - 1$  to  $j$ . This information is encoded in the values of  $x_{i,j-1}$  for  $1 \leq i \leq n$ .

In particular, group the variables into columns, with  $X_j$  denoting variables  $x_{1,j}, \dots, x_{n,j}$ , and  $Y_j$  denoting variables  $y_{1,j}, \dots, y_{n-1,j}$ . Scanning the board from left to right, consider  $X_j$  to encode the “state” of processing after completing column  $j$ . As the scanning process reaches column  $j$ , there is a *characteristic function*  $\sigma_{j-1}(X_{j-1})$  describing the set of allowed crossings of horizontally-oriented dominos from column  $j - 1$  into column  $j$ . No other information about the configuration of the board to the left is required. The characteristic function after column  $j$  can then be computed as:

$$\sigma_j(X_j) = \exists X_{j-1} [\sigma_{j-1}(X_{j-1}) \wedge \exists Y_j T_j(X_{j-1}, Y_j, X_j)] \quad (3)$$

where  $T_j(X_{j-1}, Y_j, X_j)$  is a “transition relation” consisting of the conjunction of the Exactly1 constraints for column  $j$ . From this, we can existentially quantify the variables  $Y_j$  to obtain a BDD encoding all compatible combinations of the variables  $X_{j-1}$  and  $X_j$ . By conjuncting this with the characteristic function for column  $j - 1$  and existentially quantifying the variables  $X_{j-1}$ , we obtain the characteristic function for column  $j$ . With a mutilated chessboard, we generate leaf node  $L_0$  in attempting the final conjunction. Note that Equation 3 does not represent a reformulation of the mutilated chessboard problem. It simply defines a way to schedule the conjunction and quantification operations over the input clauses.

In our experiments, we found that this scanning reaches a fixed point after processing  $n/2$  columns. That is, from that column onward, the characteristic functions become identical, except for a renaming of variables. This indicates the the set of all possible horizontal configurations stabilizes halfway across the board. Moreover, the BDD representations of the states grow as  $O(n^2)$ . For  $n = 124$ , the largest has just 3,969 nodes.

One important rule-of-thumb in symbolic model checking is that the successive values of the next-state variables must be adjacent in the variable ordering. Furthermore, the vertical variables in  $Y_j$  must be close to their counterparts in  $X_{j-1}$  and  $X_j$ . Both objectives can be achieved by ordering the variables row-wise, interleaving the variables  $x_{i,j}$  and  $y_{i,j}$ , ordering first by row index  $i$  and then by column index  $j$ . This requires the quantification operations of Equation 3 to be performed on non-root variables.

Figure 13 shows the performance we measured for the mutilated chessboard problem. Standard techniques, including linear conjunctions and bucket elimination, lead to exponential performance and can handle boards only with  $n \leq 18$ . Our “column-scanning” approach, on the other hand, yields performance that scales as  $n^{2.7}$ , allowing us to handle cases up to  $n = 124$ . Keep in mind that the problem size here should be measured as  $n^2$ , the number of squares in the board. Thus, a problem instance with  $n = 124$  is over 31 times larger than an instance with  $n = 22$ , in terms of the number of input variables and clauses.

The graph labeled “No Quantification” demonstrates the importance of including existential quantification in solving this problem. These data were generated by using the same schedule as with column scanning, but with all quantification operations omitted. As can be seen, this approach could not scale beyond  $n = 16$ .

Most attempts to generate propositional proofs of the mutilated chessboard have exponential performance. No solver in the 2018 SAT competition could handle the instance with  $n = 20$ , although we see KISSAT succeeding for  $n = 22$ , generating a proof with over 137 million clauses and a runtime of 12.6 hours. Heule, Kiesl, and Biere [25] devised a problem-specific approach that could generate proofs up to  $n = 50$  by exploiting special symmetries in the problem, using a set of rewriting rules to dramatically reduce the search space. Our approach also exploits symmetries in the problem, but by exploiting a way to compactly encode the set of possible configurations between successive columns. Other than these two, we know of no other approach for generating polynomially-sized propositional proofs for the problem.

It is interesting to reflect on how our column-scanning approach relates to SAT-based bounded model checking (BMC) [4]. This approach to verification encodes the operation of a state transition system for  $k$  steps, for some fixed value of  $k$ , by replicating the transition relation  $k$  times. It then uses a SAT solver to detect whether some condition can arise within  $k$  steps of operation. By contrast, we effectively compress the mutilated chessboard problem into a state machine that adds tiles to successive columns of the board and then perform a BDD-based reachability computation for this system, much as would a symbolic model checker [11]. Just as BDD-based model checking can outperform SAT-based BMC for some problems, we have demonstrated that a BDD-based SAT solver can sometimes outperform a search-based SAT solver.

#### 4.4 Pigeonhole Problem

The pigeonhole problem is one of the most studied problems in propositional reasoning. Given a set of  $n$  holes and a set of  $n + 1$  pigeons, it asks whether there is an assignment of pigeons to holes such that 1) every pigeon is in some hole, and 2) every hole contains at most one pigeon. The answer is no, of course, but any resolution proof for this must be of exponential length [22]. Groote and Zantema have shown that any BDD-based proof of the principle that only uses the Apply algorithm must be of exponential size [21]. On the other hand, Cook constructed an extended resolution proof of size  $O(n^4)$ , in part to demonstrate the expressive power of extended resolution [14].

We consider two encodings of the problem. Both are based on a set of variables  $p_{i,j}$  for  $1 \leq i \leq n$  and  $1 \leq j \leq n + 1$ , with the interpretation that pigeon  $j$  is assigned to hole  $i$ . Encoding the property that each pigeon  $j$  is assigned to some hole can be expressed as with a single clause:

$$Pigeon_j = \bigvee_{i=1}^n p_{i,j}$$

Encoding the property that each hole  $i$  contains at most one pigeon can be done in two different ways. A *direct* encoding simply states that for any pair of pigeons  $j$  and  $k$ , at least one of them

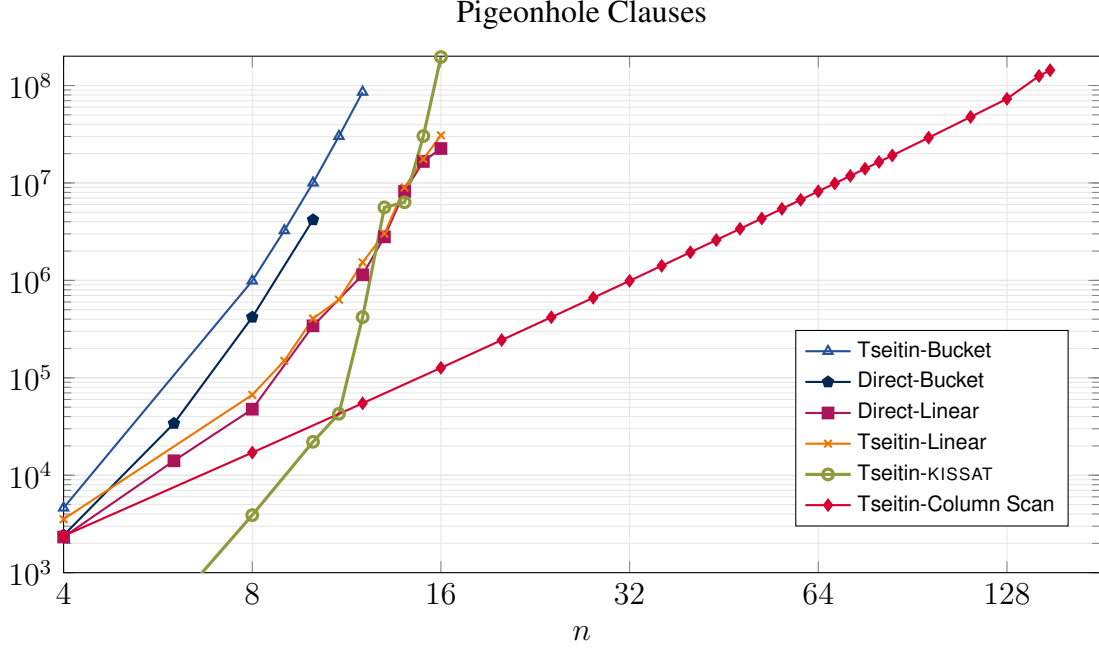

Figure 14: Total number of clauses in proofs of pigeonhole problem for  $n$  holes. Using a direct encoding led to exponential performance, but using a Tseitin encoding and column scanning gives proofs that grow as  $n^{3.0}$ .

must not be in hole  $i$ :

$$Direct_i = \bigwedge_{j=1}^{n+1} \bigwedge_{k=j+1}^{n+1} \bar{p}_{i,j} \vee \bar{p}_{i,k}$$

This encoding requires  $\Theta(n^2)$  clauses for each hole, yielding a total CNF size of  $\Theta(n^3)$ .

A second, *Tseitin* encoding introduces Tseitin variables to track which holes are occupied, starting with pigeon 1 and working upward. We use an encoding published by Sinz [37] that uses Tseitin variables  $s_{i,j}$  for  $1 \leq i \leq n$  and  $1 \leq j \leq n$ . Informally, variables  $s_{i,1}, s_{i,2}, \dots, s_{i,n}$  serves as a *signal chain* that indicates the point at which a pigeon has been assigned to hole  $i$ . For each hole  $i$ , there is a total of  $3n - 1$  clauses:

Effect	Formula	Clause	Range
Generate	$p_{i,j} \rightarrow s_{i,j}$	$\bar{p}_{i,j} s_{i,j}$	$1 \leq j \leq n$
Propagate	$s_{i,j-1} \rightarrow s_{i,j}$	$\bar{s}_{i,j-1} s_{i,j}$	$1 < j \leq n$
Suppress	$s_{i,j-1} \rightarrow \bar{p}_{i,j}$	$\bar{s}_{i,j-1} \bar{p}_{i,j}$	$1 < j \leq n + 1$

Each of these clauses serves either to define how the next value in the chain is to be computed, or to describe the effect of the signal on the allowed assignments of pigeons to the hole. That is, for hole  $i$ , the signal is *generated* at position  $j$  if pigeon  $j$  is assigned to that hole. Once set, the



signal continues to *propagate* across higher values of  $j$ . Once the signal is set, it *suppresses* further assignments of pigeons to the hole. This encoding requires  $3n - 1$  clauses and  $n$  Tseitin variables per hole, yielding an overall CNF size of  $\Theta(n^2)$ .

As is illustrated by the log-log plots of Figure 14, this choice of encoding not only affects the CNF size, it dramatically affects the size of the proofs generated by PGBDD. With a direct encoding, we could not find any combination of evaluation strategy or variable ordering that could go beyond  $n = 16$ . Similarly, the Tseitin encoding did not help when using linear evaluation or bucket elimination. Indeed, we see KISSAT, using the Tseitin encoding, matching or exceeding our program for these cases, but all of these have exponential performance.

On the other hand, the column scanning approach used for the mutilated checkerboard can also be applied to the pigeonhole problem when the Tseitin encoding is used. Consider an array with hole  $i$  represented by row  $i$  and pigeon  $j$  represented by column  $j$ . Let  $S_j$  represent the Tseitin variables  $s_{i,j}$  for  $1 \leq i \leq n$ . The “state” is then encoded in these Tseitin variables. In processing pigeon  $j$ , we can assume that the possible combinations of values of Tseitin variables  $S_{j-1}$  is encoded by a characteristic function  $\sigma_{j-1}(S_{j-1})$ . In addition, we incorporate into this characteristic function the requirement that each pigeon  $k$ , for  $1 \leq k \leq j - 1$  is assigned to some hole. Letting  $P_j$  denote the variables  $p_{i,j}$  for  $1 \leq i \leq n$ , the characteristic function at column  $j$  can then be expressed as:

$$\sigma_j(S_j) = \exists S_{j-1} [\sigma_{j-1}(S_{j-1}) \wedge \exists P_j T_j(S_{j-1}, P_j, S_j)] \quad (4)$$

where the “transition relation”  $T_j$  consists of the clauses associated with the Tseitin variables, plus the clause encoding constraint  $Pigeon_j$ . As with the mutilated chessboard, having a proper variable ordering is critical to the success of a column scanning approach. We interleave the ordering of the variables  $p_{i,j}$  and  $s_{i,j}$ , ordering them first by  $i$  (holes) and then by  $j$  (pigeons.)

Figure 14 demonstrates the effectiveness of the column-scanning approach. We were able to handle instances up to  $n = 150$ , and with an overall performance trend of  $n^{3.0}$ . Our achieved performance therefore improves on Cook’s bound of  $O(n^4)$ . A SAT-solving method developed by Heule, Kiesl, Seidl, and Biere can generate short proofs of multiple encodings, including the direct encoding [26]. These proofs are similar to ours in format after transformation and the size is also  $O(n^3)$  [24].

Unlike with the mutilated chessboard, the scanning does not reach a fixed point. Instead, the BDDs start very small, because they must encode the locations of only a small number of occupied holes. They reach their maximum size at pigeon  $n/2$ , as the number of combinations for occupied and unoccupied holes reaches its maximum of  $C(n, n/2)$ . The BDD sizes then drop off, symmetrically to the first  $n/2$  pigeons, as the encoding needs to track the positions of a decreasing number of unoccupied holes. Fortunately, all of these BDDs grow quadratically with  $n$ , reaching a maximum of 5,702 nodes for  $n = 150$ .

## 4.5 Evaluation

Overall, our results demonstrate the potential for generating small proofs of unsatisfiability using BDDs. We have achieved polynomial performance for four problems for which search-based SAT solvers have exponential performance.

Table 2: Summary data for the largest parity and Urquhart formulas solved

Instance	Parity-5000	Urquhart-Li-26
Input variables	14,944	13,884
Input clauses	39,984	37,024
Total BDD nodes	16,588,938	12,395,133
Maximum live nodes	197,465	154,511
Defining clauses	66,258,497	49,490,514
Derived clauses	43,087,669	32,105,428
Maximum live clauses	1,371,323	1,081,498
SAT time (secs)	5,180	4,413
Checking time (secs)	182	49

The success for the first two benchmark problems relies on the ability of BDDs to handle exclusive-or operations efficiently. Generally, the exclusive-or of  $k$  variables can be expressed as a BDD with  $2k + 1$  nodes, including the leaves. These representations are also independent of the variable ordering. As we saw, however, it is critical to quantify variables whenever possible, to avoid requiring the BDD to encode the parity relationships among many overlapping subsets of the variables. We found that bucket elimination works well on these problems, and that randomness in the problem structure and the variable ordering did not adversely affect performance. This strategy was outlined by Jussila, Sinz, and Biere; our experimental results serve as a demonstration of the utility of their work.

The success for the second two benchmark problems relies on finding a way to scan in one dimension, encoding the “state” of the scan in a compact form. This strategy only works when the problem is encoded in a way that it can be partitioned along two dimensions. This approach draws its inspiration from symbolic model checking, and it requires the more general capability to handle quantification that we have presented.

Other studies have compared BDDs to search-based SAT on a variety of benchmark problems. Several of these observed exponential performance for BDD-based solvers for problems for which we have obtained polynomial performance. Uribe and Stickel [41] ran experiments with the mutilated chessboard problem, but they did not do any variable quantification. Pan and Vardi [35] applied a variety of scheduling and variable ordering strategies for the mutilated chessboard and pigeonhole problems. Although they found that they could get better performance than with a search-based SAT solver, their performance still scaled exponentially. Obtaining polynomial performance requires devising more problem-specific approaches than the ones they considered. Our experiments with KISSAT confirm that a BDD-based SAT solver requires careful attention to the problem encoding, the variable ordering, and the use of quantification in order to outperform a state-of-the-search-based solver.

Tables 2–3 provide some performance data for the largest instances solved for each of the

Table 3: Summary data for the largest chess and pigeonhole problems solved

Instance	Chess-124	Pigeon-Tseitin-150
Input variables	30,500	45,150
Input clauses	106,136	67,501
Total BDD nodes	3,409,112	17,861,833
Maximum live nodes	198,967	225,446
Defining clauses	12,127,031	62,585,397
Derived clauses	5,348,303	81,019,084
Maximum live clauses	751,944	1,297,039
SAT time (secs)	5,366	5,206
Checking time (secs)	30	240

four benchmark problems. A first observation is that these problems are very large, with tens of thousands of input variables and clauses.

Looking at the BDD data, the total number of BDD nodes indicates the total number generated by the function `GETNODE`, and for which extension variables are created. These are numbered in the millions, and far exceed the number of input variables. On the other hand, the maximum number of live nodes shows the effectiveness of garbage collection—at any given point in the program, only a small fraction (at most 6%) of the total number of nodes must be stored in the unique table and tracked in the operation cache.

The set of clauses in the proof consists of the input clauses, the defining clauses, and the derived clauses representing resolution steps. There can be at most four defining clauses per BDD node generated. As can be seen, the average number ranges between 3.50 (pigeonhole) to 3.99 (parity and Urquhart), indicating that most nodes (between 50% and 99.8%) have two non-leaf nodes as children. There is one derived clause generated per input clause, and there can be at most two derived clauses for each step of the `APPLYAND` or `PROVEIMPLICATION` operation. The average ranges between 1.47 (chess) and 1.99 (parity and Urquhart). The maximum number of live clauses equals the maximum number that the proof checker needs to manage, as clauses are added and deleted. As can be seen, this number stays below 4.3% of the total.

The elapsed time for the SAT solver ranges up to 1.5 hours. We believe, however, that an implementation in a more performant language would reduce these times greatly. Indeed, with a more capable BDD package, we could easily handle benchmarks that would overwhelm the proof checker and that would generate files too large for many file systems. The checking times are shown for an LRAT proof checker written in the C programming language. The proofs have also been checked with a formally verified proof checker based on the HOL theorem prover [39].

None of these problems would be especially challenging for more advanced BDD packages. The key metric is the maximum number of live nodes, because this determines the maximum amount of memory that would be required. We see that the benchmarks require no more than

230,000 live nodes, whereas other BDD packages can routinely manage tens of millions of nodes.

## 5 Conclusion

The pioneering work by Biere, Sinz, and Jussila [28, 38] did not lead to as much follow-on work as it deserved. Here, fifteen years later, we found that small modifications to their approach enable a powerful, BDD-based SAT solver to generate proofs of unsatisfiability. The key to its success is the ability to perform arbitrary existential quantification. As the experimental results demonstrate, such a capability is critical to obtaining reasonable performance.

More advanced BDD-based SAT solvers employ additional techniques to improve their performance. Extending our methods to handle these techniques would be required to have them generate proofs of unsatisfiability. Some of these would be straightforward. For example, Weaver, Franco, and Schlipf [43] derive a very general set of conditions under which existential quantification can be applied while preserving satisfiability. For generating proofs of unsatisfiability, our ability to prove that existential quantification preserves implication would be sufficient for all of these cases. On the other hand, more advanced solvers, such as SBSAT [19], employ a variety of techniques to prune the intermediate BDDs based on the structure of other BDDs that remain to be conjuncted. This pruning generally reduces the set of satisfying assignments to the BDD, and so implication does not hold.

The ability to generate correctness proofs in a BDD-based SAT solver invites us to consider generating proofs for other tasks to which BDDs are applied. We have already done so for quantified Boolean formulas, demonstrating the ability to generate proofs for both true and false formulas in a unified framework [9]. Other problems of interest include model checking, and model counting. Perhaps a proof of unsatisfiability could provide a useful building block for constructing correctness proofs for these other tasks.

We would like to thank Chu-Min Li and Laurent Simon for sharing their programs for generating the two classes of Urquhart benchmarks evaluated in Section 4.2.

## References

- [1] Michael Alekhovich. Mutilated chessboard problem is exponentially hard for resolution. *Theoretical Computer Science*, 310(1-3):513–525, January 2004.
- [2] Henrik Reif Andersen. An introduction to binary decision diagrams. Technical report, Technical University of Denmark, October 1997.
- [3] Armin Biere. CaDiCaL at the SAT race. unpublished, 2019.
- [4] Armin Biere, Alessandro Cimatti, Edmund M. Clarke, and Yunshan Zhu. Symbolic model checking without BDDs. In *Tools and Algorithms for the Construction and Analysis of Systems (TACAS)*, volume 1579 of *LNCS*, pages 193–207, 1999.

- [5] Armin Biere, Katalin Fazekas, Mathias Fleury, and Maximilian Heisinger. CaDiCaL, Kissat, Paracooba, Plingeling, and Treengeling entering the SAT competition 2020. unpublished, 2020.
- [6] Randal E. Bryant. Graph-based algorithms for Boolean function manipulation. *IEEE Trans. Computers*, 35(8):677–691, 1986.
- [7] Randal E. Bryant. Symbolic Boolean manipulation with ordered binary decision diagrams. *ACM Computing Surveys*, 24(3):293–318, September 1992.
- [8] Randal E. Bryant. Binary decision diagrams. In Edmund M. Clarke, Thomas A. Henzinger, Helmut Veith, and Roderick Bloem, editors, *Handbook of Model Checking*, pages 191–217. Springer, 2018.
- [9] Randal E. Bryant and Marijn J. H. Heule. Dual proof generation for quantified Boolean formulas with a BDD-based solver. In *Conference on Automated Deduction (CADE)*, 2021.
- [10] Randal E. Bryant and Marijn J. H. Heule. Generating extended resolution proofs with a BDD-based SAT solver. In *Tools and Algorithms for the Construction and Analysis of Systems (TACAS), Part I*, volume 12651 of *LNCS*, pages 76–93, 2021.
- [11] Jerry R. Burch, Edmund M. Clarke, Kenneth L. McMillan, David L. Dill, and L. J. Hwang. Symbolic model checking:  $10^{20}$  states and beyond. *Information and Computation*, 98(2):142–170, 1992.
- [12] Philippe Chatalic and Laurent Simon. ZRes: The old Davis-Putnam procedure meets ZBDD. In *Conference on Automated Deduction (CADE)*, volume 1831 of *LNCS*, pages 449–454, 2000.
- [13] Leroy Chew and Marijn J. H. Heule. Sorting parity encodings by reusing variables. In *Theory and Applications of Satisfiability Testing (SAT)*, volume 12178 of *LNCS*, pages 1–10, 2020.
- [14] Stephen A. Cook. A short proof of the pigeon hole principle using extended resolution. *SIGACT News*, 8(4):28–32, October 1976.
- [15] Luís Cruz-Filipe, Marijn J. H. Heule, Warren A. Hunt, Matt Kaufmann, and Peter Schneider-Kamp. Efficient certified RAT verification. In *Conference on Automated Deduction (CADE)*, volume 10395 of *LNCS*, pages 220–236, 2017.
- [16] Luís Cruz-Filipe, João Marques-Silva, and Peter Schneider-Kamp. Efficient certified resolution proof checking. In *Tools and Algorithms for the Construction and Analysis of Systems (TACAS)*, volume 10205 of *LNCS*, pages 118–135, 2017.
- [17] Martin Davis and Hilary Putnam. A computing procedure for quantification theory. *J.ACM*, 7(3):201–215, 1960.

- [18] Rina Dechter. Bucket elimination: A unifying framework for reasoning. *Artificial Intelligence*, 113(1–2):41–85, 1999.
- [19] John Franco, Michal Kouril, John Schlipf, Jeffrey Ward, Sean Weaver, Michael Dransfield, and W. Mark Vanfleet. SBSAT: a state-based, BDD-based satisfiability solver. In *Theory and Applications of Satisfiability Testing (SAT)*, volume 2919 of *LNCS*, pages 398–410, 2004.
- [20] Ofer Gabber and Zvi Galil. Explicit construction of linear-sized superconcentrators. *Journal of Computer and System Sciences*, 22:407–420, 1981.
- [21] Jan F. Groote and H. Zantema. Resolution and binary decision diagrams cannot simulate each other polynomially. *Discrete Applied Mathematics*, 130(2):157–171, 2003.
- [22] Armin Haken. The intractability of resolution. *Theoretical Computer Science*, 39:297–308, 1985.
- [23] Marijn J. H. Heule and Armin Biere. Proofs for satisfiability problems. In *All about Proofs, Proofs for All (APPA)*, volume 55 of *Math. Logic and Foundations*. College Pub., 2015.
- [24] Marijn J. H. Heule and Armin Biere. What a difference a variable makes. In *Tools and Algorithms for the Construction and Analysis of Systems (TACAS)*, volume 10806 of *LNCS*, pages 75–92, 2018.
- [25] Marijn J. H. Heule, Benjamin Kiesl, and Armin Biere. Clausal proofs of mutilated chessboards. In *NASA Formal Methods*, volume 11460 of *LNCS*, pages 204–210, 2019.
- [26] Marijn J. H. Heule, Benjamin Kiesl, Martina Seidl, and Armin Biere. PRuning through satisfaction. In *Haifa Verification Conference (HVC)*, volume 10629 of *LNCS*, pages 179–194, 2017.
- [27] Shlomo Hoory, Nathan Linial, and Avi Wigderson. Expander graphs and their applications. *Bulletin of the American Mathematical Society*, 43(4):439–561, October 2006.
- [28] Toni Jussila, Carsten Sinz, and Armin Biere. Extended resolution proofs for symbolic SAT solving with quantification. In *Theory and Applications of Satisfiability Testing (SAT)*, volume 4121 of *LNCS*, pages 54–60, 2006.
- [29] Oliver Kullmann. On a generalization of extended resolution. *Discrete Applied Mathematics*, 96-97:149–176, 1999.
- [30] Peter Lammich. Efficient verified (UN)SAT certificate checking. *Journal of Automated Reasoning*, 64:513–532, 2020.
- [31] Chu-Min Li. Equivalent literal propagation in the DLL procedure. *Discrete Applied Mathematics*, 130(2):251–276, 2003.
- [32] Gregori A. Margulis. Explicit construction of concentrators. *Probl. Perdachi Info (Problems in Information Transmission)*, 9(4):71–80, 1973.

- [33] Donald Michie. ‘Memo’ functions and machine learning. *Nature*, 218:19–22, 1968.
- [34] Shin-Ichi Minato, Nagisa Ishiura, and Shuzo Yajima. Shared binary decision diagrams with attributed edges for efficient Boolean function manipulation. In *Design Automation Conference (DAC)*, pages 52–57, June 1990.
- [35] Guoqiang Pan and Moshe Y. Vardi. Search vs. symbolic techniques in satisfiability solving. In *Theory and Applications of Satisfiability Testing (SAT)*, volume 3542 of *LNCS*, pages 235–250, 2005.
- [36] John A. Robinson. A machine-oriented logic based on the resolution principle. *J.ACM*, 12(1):23–41, January 1965.
- [37] Carsten Sinz. Towards an optimal CNF encoding of Boolean cardinality constraints. In *Principles and Practice of Constraint Programming (CP)*, volume 3709 of *LNCS*, pages 827–831, 2005.
- [38] Carsten Sinz and Armin Biere. Extended resolution proofs for conjoining BDDs. In *Computer Science Symposium in Russia (CSR)*, volume 3967 of *LNCS*, pages 600–611, 2006.
- [39] Yong Kiam Tan, Marijn J. H. Heule, and Magnus O. Myreen. cake\_lpr: Verified propagation redundancy checking in CakeML. In *Tools and Algorithms for the Construction and Analysis of Systems (TACAS), Part II*, volume 12652 of *LNCS*, pages 223–241, 2021.
- [40] Gregori S. Tseitin. On the complexity of derivation in propositional calculus. In *Automation of Reasoning: 2: Classical Papers on Computational Logic 1967–1970*, pages 466–483. Springer, 1983.
- [41] Tomás E. Uribe and Mark E. Stickel. Ordered binary decision diagrams and the Davis-Putnam procedure. In *Constraints in Computational Logics*, volume 845 of *LNCS*, pages 34–49, 1994.
- [42] Alasdair Urquhart. The complexity of propositional proofs. *The Bulletin of Symbolic Logic*, 1(4):425–467, 1995.
- [43] Sean Weaver, John V. Franco, and John S. Schlipf. Extending existential quantification in conjunctions of BDDs. *JSAT*, 1(2):89–110, 2006.
- [44] Nathan D. Wetzler, Marijn J. H. Heule, and Warren A. Hunt Jr. DRAT-trim: Efficient checking and trimming using expressive clausal proofs. In *Theory and Applications of Satisfiability Testing (SAT)*, volume 8561 of *LNCS*, pages 422–429, 2014.
- [45] Lintao Zhang and Sharad Malik. Validating SAT solvers using an independent resolution-based checker: Practical implementations and other applications. In *Design, Automation and Test in Europe (DATE) Volume 1*, page 10880. IEEE Computer Society, 2003.