

Unique Ergodicity in the Interconnections of Ensembles with Applications to Two-Sided Markets

R. Ghosh, W. M. Griggs, J. Mareček, and R. N. Shorten

Abstract—There has been much recent interest in two-sided markets and dynamics thereof. In a rather a general discrete-time feedback model, we show conditions that ensure that for each agent, there exists the limit of a long-run average allocation of a resource to the agent, which is independent of any initial conditions. We call this property unique ergodicity.

Our model encompasses two-sided markets and more complicated interconnections of workers and customers, such as in a supply chain. It allows for non-linearity of the response functions of market participants. It allows for uncertainty in the response of market participants by considering a set of the possible responses to either price or other signals and a measure to sample from these. Finally, it allows for an arbitrary delay between the arrival of incoming data and the clearing of a market.

I. INTRODUCTION

Motivated by the success of the business models of Uber Technologies, Inc. or Upwork Global Inc., and following Jean Tirole’s pioneering research [1, 2, 3, 4, e.g.], there has been much recent work on two-sided and multi-sided markets [5, 6, 7, 8, e.g.]. One would like to analyse the long-run properties of such markets, including their stability and fairness.

We consider a discrete-time feedback model of an interconnection of ensembles:

- encompassing two-sided markets and more complicated interconnections in multi-sided markets,
- allowing for non-linearity of the response functions of market participants,
- allowing for uncertainty in the response of market participants by considering a set of the possible responses to either price or other signals and a measure to sample from these,
- allowing for an arbitrary delay between the arrival of incoming data and the clearing of a market. Outside of finite-speed information transmission, this can model the buffering (prior to market clearing by matching) in many two-sided markets.

Our model applies even to settings where the organising entity divides resources among agents, based on the information

reported by the agents without payments, which is important within “artificial intelligence for social good”. While one can leverage auditing mechanisms to maximize utility in repeated allocation problems where payments are not possible [9], our results can be seen as conditions on the information exchange, as well as prices, that allow for certain desirable properties.

Our results concern certain desirable properties of such models and certain testable conditions assuring these properties [10]. Informally speaking, we call a feedback system uniquely ergodic, when for each agent i , there exists the limit of a long-run average allocation of a resource to the agent, which is independent of any initial conditions. In turn, the notion of unique ergodicity underlies a natural notion of fairness, distinct from other popular notions of fairness [11], where the limit coincides across all agents or market participants. A necessary condition for the feedback system to be uniquely ergodic is for the system to be contractive on average, in a sense we formalise below.

A. An Application: Two-Sided Markets

Important applications lie within two-sided markets [2, 3, 4, 12], which model online labour platforms that enable the interaction between the two sides: customers submitting jobs over time, and workers performing jobs. For example, the ride-hailing systems of Uber, Lyft, or Didi Chuxing can be modelled as a two-sided market with direct connections. In this case, workers would be Uber drivers and jobs can be the rides of customers. Note that jobs are assumed to be independent from each other, although one customer might offer multiple jobs.

See Figure 1 (right) for an overview of our model of such a two-sided market: controller \mathcal{C}^1 suggests prices π^1 (known as driver surge pricing [13, 14, 15, 16, 17] in Uber) to customers \mathcal{S}_i^1 , whose requests $y_i^1(k)$ for jobs (rides) at time k are based on some internal state of each customer i at time k , $x_i^1(k)$, which are not directly observable. A controller \mathcal{C}^2 for the other side of the market matches the jobs (rides) to workers (driver-partners) \mathcal{S}_i^2 whose state $x_i^2(k)$ at time k may be partially observable (e.g., availability, position) and partially not observable (e.g., appetite for further work that day).

Usually [18, 19, 20, 21, 22, e.g.], \mathcal{C}^2 is implemented using an on-line matching algorithm. Its matches $\pi^2(k)$ are provided to the workers (drivers), whose acceptance rate $y_i^1(k)$

R. Ghosh is at University College Dublin, Dublin, Ireland.

W. M. Griggs is at Monash University, Melbourne, Victoria, Australia.

J. Mareček is at the Czech Technical University, Prague, the Czech Republic.

R. N. Shorten is at Imperial College London, South Kensington, UK.

of the matches is then input into the controller \mathcal{C}^1 that suggests prices (with driver surge pricing implemented, if many matches go unaccepted, or there simply are not enough drivers).

B. Another Application: Multi-sided Platforms

Further important applications lie within multi-sided platforms [5, 6, 7] and networked markets [8]. To continue our ride-hailing example, one could see the ride-hailing systems of Uber as a multi-sided market, if one also considers “fleet partners” (who are intermediaries for car manufacturers and car leasing providers) and taxi operators. Indeed, Uber’s Vehicle Solutions Program is a platform for fleet partners to offer their vehicles to driver partners. Drivers, in turn, sometimes happen to work also as licensed taxi drivers.

Similarly, Google’s Android ecosystem and Microsoft’s Windows ecosystem are sometimes seen [6, 23] as three-sided platforms connecting consumers, software providers, and hardware providers. While some of the incentives offered to independent software providers (e.g., free hardware samples, no-cost licenses of development tools) are not being adjusted in real-time, others (e.g., promotions for their apps) are. The details of the control mechanisms have not been made public in this case.

C. Contributions and Paper Organization

For these – and many other – applications, we present:

- a novel model of two-sided markets and extensions towards more general interconnections of ensembles of agents,
- a notion of unique ergodicity, which can be seen as individual-level predictability of the outcomes in a certain closed-loop sense,
- conditions ensuring unique ergodicity,
- conditions ruling out unique ergodicity in the same sense.

Our model is based on our earlier work on ensemble control [10], which we extend from having a central organising entity and all agents responding to prices it sets or signals it provides, towards having two-sided markets or more complicated interconnections. The differences are illustrated in Figure 1: on the left is the model used in our earlier work; on the right, the present model.

Our negative results utilise coupling arguments developed by Hairer [24] within the study of stochastic differential equations. Our positive results are based on iterated function systems [25, 26, 27]. Iterated function systems (IFS), albeit not well known in the Economics community, are a convenient and rich class of Markov processes. As it will be seen in the sequel, a two-sided markets can be modelled and analysed using IFS in a particularly natural way. The use of IFS makes it possible to obtain strong stability guarantees for such stochastic systems.

The paper is organised as follows: In Section II, we present our model and necessary mathematical background from the theory of discrete time Markov chains, iterated function systems

and recall the concept of coupling of invariant measures in order to state a necessary condition for ergodicity, our main results are established in section III on statistical stability of two sided market which is modelled by the closed loop system as in figure 1, where in Theorem 9 we state the result assuming that the agents states are evolved as a linear-time-invariant dynamical system, in Theorem 13 states are governed by non-linear iterated function system and in Theorem 16 we assume that the agents state has discrete-range space. In Section IV we extend our results obtained in Section III for the interconnection of N number of ensemble of systems, section V discusses our result adding time delay in our system. And finally in Section VIII, we highlights some directions for future research.

II. PRELIMINARIES, NOTATION, AND THE DESCRIPTION OF OUR MODEL

In this article, we intend to extend and generalize our results from [10] about the closed-loop, discrete time dynamical systems of the form depicted in Figure 1, consist of a number $N \in \mathbb{N}$ denote the total number of agents, \mathcal{F} denote the filter, and a controller \mathcal{C} , which act for the central authority to produce a signal $\pi(k)$ at time k . In response, the agents, modelled by the systems $\mathcal{S}_1, \mathcal{S}_2, \dots, \mathcal{S}_N$, modify their use of the resource.

Let $(\mathbb{X}, \mathcal{B})$ denote a measurable state-space, where (\mathbb{X}, ρ) is a metric space with ρ a metric on it. In most of our discussions, \mathbb{X} is the Euclidean space \mathbb{R}^n or a closed subset of it, ρ is the usual Euclidean metric, and \mathcal{B} is a Borel σ -algebra on it. $\mathcal{M}(\mathbb{X})$ denote the space of all Borel probability measures on \mathbb{X} , and \mathbb{X}^∞ denotes its associated path space [24, Section 1.1.1], which consists of infinite right-sided sequences over \mathbb{X} , i.e., a typical element in the path space would look like $\{(x(0), x(1), \dots, x(n), x(n+1), \dots) : x(i) \in \mathbb{X} \text{ for all } i \in \mathbb{N}\}$. $(\Omega, \mathcal{B}, \mathbb{P})$ be a probability space where $\Omega \equiv \mathbb{X}$ or \mathbb{X}^∞ depending on the context and \mathbb{P} is the probability on it.

The internal state of the agents in the network is denoted by $x_i(k)$, $i = 1, 2, \dots, N$. In particular, for all $i = 1, 2, \dots, N$ $x_i(k)$ is a random variable. We model the use of the resource $y_i(k)$ of agent i at time k as the output of system \mathcal{S}_i , which is again a random variable. In the remainder we will assume $y_i(k)$ and $\pi(k)$ are scalars, but generalizations are easy to obtain. The randomness can be a result of the inherent randomness in the reaction of user i to the control signal $\pi(k)$, or the response to a control signal that is intentionally randomized [28, 29, 30]. The aggregate resource utilisation

$$y(k) := \sum_{i=1}^N y_i(k) \quad (1)$$

at time k are then also random variables. The controller may not have access to either $x_i(k)$, $y_i(k)$ or $y(k)$, but only to the error signal $e(k)$, which is the difference of $\hat{y}(k)$, the output of a filter \mathcal{F} , and r , the desired value of $y(k)$, i.e

$$e(k) := \hat{y}(k) - r. \quad (2)$$

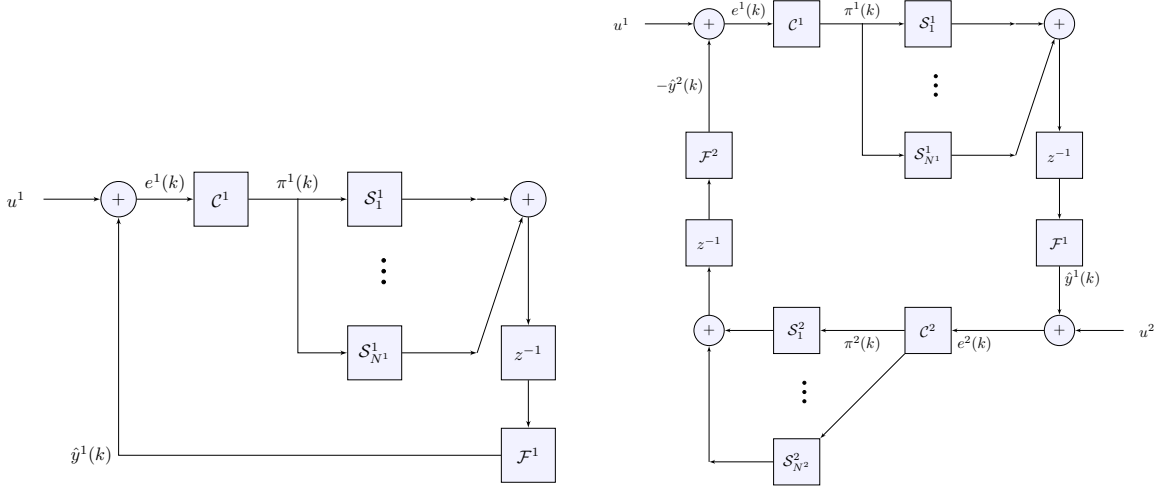

Fig. 1. Left: The feedback model of Fioravanti et al. [10], depicted utilizing our notation. Right: Our feedback model of a two-sided market.

Let Π denotes the set of all admissible broadcast control signals. Assume that the controller has its private state $x_c(k) \in \mathbb{R}^{n_c}$ and aims to regulate the system 1 by providing a signal $\pi(k) \in \Pi \subseteq \mathbb{R}$ at time k . In the simpler static case, the signal $\pi(k)$ is a function of an error signal $e(k)$ and the controller state $x_c(k)$, whose range is Π .

In the case of purely discrete agents, the non-deterministic agent-specific response to the feedback signal $\pi(k) \in \Pi$ can be modelled by agent-specific and signal-specific probability distributions over certain agent-specific set of actions $\mathbb{A}_i = \{a_1, \dots, a_L\} \subset \mathbb{R}^{n_i}$, where \mathbb{R}^{n_i} can be seen as the space of agent's i private state x_i . Assume that the set of possible resource demands of agent i is \mathbb{D}_i , where in the case that \mathbb{D}_i is finite, we denote

$$\mathbb{D}_i := \{d_{i,1}, d_{i,2}, \dots, d_{i,m_i}\}. \quad (3)$$

In the general case, we assume there are $w_i \in \mathbb{N}$ state transition maps $\mathcal{W}_{ij} : \mathbb{R}^{n_i} \rightarrow \mathbb{R}^{n_i}$, $j = 1, \dots, w_i$ for agent i and $h_i \in \mathbb{N}$ output maps $\mathcal{H}_{i\ell} : \mathbb{R}^{n_i} \rightarrow \mathbb{D}_i$, $\ell = 1, \dots, h_i$ for each agent i . The evolution of the states and the corresponding demands then satisfy:

$$x_i(k+1) \in \{\mathcal{W}_{ij}(x_i(k)) \mid j = 1, \dots, w_i\}, \quad (4)$$

$$y_i(k) \in \{\mathcal{H}_{i\ell}(x_i(k)) \mid \ell = 1, \dots, h_i\}, \quad (5)$$

where the choice of agent i 's response at time k is governed by probability functions $p_{ij} : \Pi \rightarrow [0, 1]$, $j = 1, \dots, w_i$, respectively $p'_{i\ell} : \Pi \rightarrow [0, 1]$, $\ell = 1, \dots, h_i$. Specifically, for each agent i , we have for all $k \in \mathbb{N}$ that

$$\mathbb{P}(x_i(k+1) = \mathcal{W}_{ij}(x_i(k))) = p_{ij}(\pi(k)), \quad (6a)$$

$$\mathbb{P}(y_i(k) = \mathcal{H}_{i\ell}(x_i(k))) = p'_{i\ell}(\pi(k)). \quad (6b)$$

Additionally, for all $\pi \in \Pi$, $i = 1, \dots, N$ it holds that

$$\sum_{j=1}^{w_i} p_{ij}(\pi) = \sum_{\ell=1}^{h_i} p'_{i\ell}(\pi) = 1. \quad (6c)$$

We assume that the random variables $\{x_i(k+1) \mid i =$

$1, \dots, N\}$ which are conditioned on $\{x_i(k)\}, \pi(k)$, but stochastically independent. The outputs $y_i(k)$ each depend on $x_i(k)$ and the signal $\pi(k)$ only. The behaviour of the overall system in response to the signal $\pi(k)$ can be modelled by the operator P as $P : \mathbb{X} \times \Pi \rightarrow \mathcal{M}(\mathbb{X})$. In order to reason about the evolution of the state, consider the space \mathbb{X}^∞ and we introduce the space of probability measures on $\mathcal{M}(\mathbb{X}^\infty)$ with the product σ -algebra.

The set-up described in the prequel resembles closely that of an iterated function system [25, 26, 27]. Iterated function systems are a class of stochastic dynamical systems, for which strong stability and convergence results exist on compact or complete and separable metric spaces as a system's state space, see [26, 31, 32, 33, 34, 35, 36, 37, 38, 39, 40, 41, 42, 43, 44, 45, 46]. We now introduce some notation and mention some of the most important results.

Definition 1. A discrete-time, time-homogeneous Markov chain on \mathbb{X} is a sequence of \mathbb{X} -valued random vectors $\{X(k)\}_{k \in \mathbb{N}}$ with the Markov property, which is the equality of a probability of an event conditioned on past events and probability of the same event conditioned on the current state, i.e.,

$$\begin{aligned} \mathbb{P}(X(k+1) \in \mathbb{G} \mid X(j) = x_j, j = 0, 1, \dots, k) \\ = \mathbb{P}(X(k+1) \in \mathbb{G} \mid X(k) = x_k), \end{aligned} \quad (7)$$

Definition 2. Let $\{f_i\}_{i=1}^m$ be continuous self-transformations on \mathbb{X} and $\{p_i(x)\}_{i=1}^m$ be probability functions on $\mathcal{B}(\mathbb{X})$, such that,

$$p_i(x) : \mathbb{X} \rightarrow [0, 1] \quad \forall i \in [1, m], \text{ and } \sum_{i=1}^m p_i(x) = 1.$$

The pair of sequences

$$(f_1(x), f_2(x), \dots, f_m(x); p_1(x), p_2(x), \dots, p_m(x))$$

is called an iterated function system (IFS).

Any discrete-time Markov chain can be generated by an iterated function system with probabilities see Kifer[47, Section 1.1] or [48, Page 228], although such representation is not unique, see, Stenflo [34]. Informally, the corresponding discrete-time Markov process on \mathbb{X} evolves as follows: choose an initial point $x_0 \in \mathcal{X}$. Select an integer from the set $[1, m]$ in such a way that the probability of choosing σ is $p_\sigma(x_0)$, $\sigma \in [1, m]$. When the number σ_0 is drawn, define

$$x_1 = f_{\sigma_0}(x_0).$$

Having x_1 , we select σ_1 according to the distribution

$$p_1(x_1), p_2(x_1), \dots, p_m(x_1),$$

and we define

$$x_2 = f_{\sigma_1}(x_1),$$

and so on.

Let us denote ν_n for $n = 0, 1, 2, \dots$, the distribution of x_n , i.e.,

$$\nu_n(B) = \mathbb{P}(x_n \in B) \text{ for some } B \in \mathcal{B}. \quad (8)$$

The above procedure can be formalized for a given $x \in \mathcal{X}$ and a Borel subset $B \in \mathcal{B}$, we may easily show that the transition operator for the given IFS is of the form:

$$\nu(x, B) := \sum_{i=0}^N 1_B(w_i(x)) p_i(x), \quad (9)$$

$\nu(x, B)$ is the transition probability from x to B . where 1_B denotes the characteristic function of B :

$$1_B := \begin{cases} 1 & \text{if } x \in B. \\ 0 & \text{if } x \in B^c. \end{cases}$$

Definition 3. The transition operator P of the Markov chain is defined for $x \in \Sigma, \mathbb{G} \in \mathcal{B}$ by

$$P(x, \mathbb{G}) := \mathbb{P}(X(k+1) \in \mathbb{G} \mid X(k) = x). \quad (10)$$

Definition 4 (Invariant probability measure [26, 42]). If the initial condition X_0 is distributed according to an initial distribution μ , we denote by \mathbb{P}_μ the probability measure induced on the path space, i.e., space of sequences with values in Σ . Conditioned on an initial distribution λ , the random variable $X(k)$ is distributed according to the measure μ_k which is determined inductively by

$$\mu_{k+1}(\mathbb{G}) := \int_{\Sigma} P(x, \mathbb{G}) \mu_k(dx), \quad (11)$$

for $\mathbb{G} \in \mathcal{B}$. A measure μ^* on Σ is called invariant with respect to the Markov process $\{X(k)\}$ if it is a fixed point for the iteration described by (11), i.e., if

$$P\mu^* = \mu^*. \quad (12)$$

Definition 5. An invariant probability measure μ is called attractive, if for every probability measure ν the sequence $\{\lambda_k\}$ defined by (11) with initial condition ν converges to μ

in distribution. The existence of attractive invariant measures is intricately linked to the ergodic properties of the system.

With this background, our general problem considered in this paper is modelled as a Markov chain on a state space representing all system components. Let $\mathbb{X}_{\mathcal{F}}$ be the product space of the state spaces of all agents. The spaces $\mathbb{X}_{\mathcal{F}}, \mathbb{X}_{\mathcal{C}}$ contain the possible internal states for filter and central controller. Our system thus evolves on the state space $\mathbb{X} := \mathbb{X}_{\mathcal{F}} \times \mathbb{X}_{\mathcal{C}} \times \mathbb{X}_{\mathcal{F}}$, as we will see in the following sections.

Notice that for a particular combination of a filter \mathcal{F} , controller \mathcal{C} , and population of agents, the feedback loop can be modelled by an operator $\mathcal{P}_k : \mathcal{M}(\mathbb{X}) \rightarrow \mathcal{M}(\mathbb{X})$ and the associated dynamical system $(\mathcal{P}_k)_{k \in \mathbb{N}}$. Our paper, at some level, asks what properties of \mathcal{C} and \mathcal{F} make $(\mathcal{P}_k)_{k \in \mathbb{N}}$ predictable and what properties of \mathcal{C} render it impossible for it to be predictable. Predictability is related to asymptotic convergence in probability in terms of measures over the path space, i.e., $\mathcal{M}(\mathbb{X}^\infty)$, and will be conveniently characterised in the next section in terms of the existence of a unique invariant measure, in the language of Markov chains.

Our specific aim is to distribute the resource such that we achieve the following goals almost surely, i.e., with probability 1:

Definition 6. Given an upper bound $r > 0$ for the utilization of the resource, we require for all $k \in \mathbb{N}$

$$\sum_{i=1}^N y_i(k) = y(k) \leq r. \quad (13)$$

More generally, the resource could be time-varying; for the purposes of this paper it will be assumed to be a constant quantity.

Definition 7 (Unique ergodicity). We call a feedback system uniquely ergodic, when for each agent i , there exists a constant \bar{r}_i such that

$$\lim_{k \rightarrow \infty} \frac{1}{k+1} \sum_{j=0}^k y_i(j) = \bar{r}_i, \quad (14)$$

where this limit is independent of the initial conditions.

Further optional requirements may include: fairness, which could be formulated by saying that all the \bar{r}_i coincide, and optimality so that the vector $\bar{r} = [\bar{r}_1 \dots \bar{r}_N]$ is an optimum of some associated optimization problem. In addition, it is also of interest to achieve the goal after a transient phase, i.e., for all $k \geq K$, where K is a constant.

While all of these goals are important from a practical perspective, the principal property of interest in this paper is the goal of predictability. To analyze this more formally, we consider an augmented state space $\mathbb{X} \subset \mathbb{R}^d$, which captures the state of the controller, the filter, and the agents.

In our positive results, we consider a class of Markov chains that are known as iterated function systems (IFSs). In an iterated function system, we are given a set of maps $\{f_j :$

$\mathbb{X} \rightarrow \mathbb{X} \mid j \in \mathbb{J}$, where \mathbb{J} is a (finite or countable) index set. Associated to these maps, there are probability functions $p_j : \mathbb{X} \rightarrow [0, 1]$, where $\sum_{j \in \mathbb{J}} p_j(x) = 1$ for all $x \in \mathbb{X}$. The state $X(k+1)$ at time $k+1$ is then given by $f_j(X(k))$ with probability $p_j(X(k))$, where $X(k)$ is the state at time k . Such IFSs have been studied in fractal image compression [49], congestion management in computer networking [50] and transportation [51], and to some extent, control theory at large [52, 53, 54].

The central technique of proving the unique ergodicity of an IFS is by using several contractivity conditions. Sufficient conditions for the existence of a unique attractive invariant measure can be given in terms of “average contractivity”. This key notion can be traced back to [25, 55, 27]:

Theorem 8. [55, Theorem 2.1] *Let $\mathbb{X} \subset \mathbb{R}^n$ be closed. Consider an IFS with a finite index set \mathbb{J} , and globally Lipschitz continuous maps $f_j : \mathbb{X} \rightarrow \mathbb{X}$, $j \in \mathbb{J}$. Assume that the probability functions p_j are globally Lipschitz continuous and bounded below by $\eta > 0$. If there exists a $\delta > 0$ such that for all $x, y \in \mathbb{X}$, $x \neq y$*

$$\sum_{j \in \mathbb{J}} p_j(x) \log \left(\frac{\|f_j(x) - f_j(y)\|}{\|x - y\|} \right) < -\delta < 0,$$

then there exists an attractive (and hence unique) invariant probability measure μ for the IFS.

We can combine Theorem 8 with a result by Elton [25, Corollary 1], to obtain that for all (deterministic) initial conditions $x_0 \in \mathbb{X}$ and continuous $g : \mathbb{X} \rightarrow \mathbb{R}$, the limit

$$\lim_{k \rightarrow \infty} \frac{1}{k+1} \sum_{\nu=0}^k g(X(\nu)) = \mathbb{E}_\mu(g) \quad (15)$$

exists almost surely (\mathbb{P}_{x_0}) and is independent of $x_0 \in \mathbb{X}$. The limit is given by the expectation with respect to the invariant measure μ .

For more general theorems, the reader is referred to [25, 55, 27, 49, 35, 44, 32, 56, 57] and surveys [31, 58, 37].

As we have discussed before, this notion precisely guarantees the property of predictability and can be used for an analysis of fairness and optimality.

III. AN INTERCONNECTION RESULT FOR TWO ENSEMBLE SYSTEMS

Let us consider a two-sided market, where one side is modelled by participants:

$$\mathcal{F}_i^1 : \begin{cases} x_i^1(k+1) &= A_i^1 x_i^1(k) + b_i^1, \\ y_i^1(k) &= c_i^{1T} x_i^1(k) + d_i^1, \end{cases} \quad (16)$$

for $i = 1, 2, \dots, N_1$, responding to the control signal π^2 produced by

$$\mathcal{C}^1 : \begin{cases} x_c^1(k+1) &= A_c^1 x_c^1(k) + B_c^1 e^1(k), \\ \pi^1(k) &= C_c^1 x_c^1(k) + D_c^1 e^1(k), \end{cases} \quad (17)$$

where the error signal depends on the filtered state of the other side of the market:

$$e^1(k) = u^1(k) - \hat{y}^2(k) \quad (18)$$

The first side has its state filtered too:

$$\mathcal{F}^1 : \begin{cases} x_f^1(k+1) &= A_f^1 x_f^1(k) + B_f^1 y^1(k), \\ \hat{y}^1(k) &= C_f^1 x_f^1(k). \end{cases} \quad (19)$$

The other side of the market is modelled by another population of participants:

$$\mathcal{F}_i^2 : \begin{cases} x_i^2(k+1) &= A_i^2 x_i^2(k) + b_i^2, \\ y_i^2(k) &= c_i^{2T} x_i^2(k) + d_i^2, \end{cases} \quad (20)$$

for $i = 1, 2, \dots, N_2$, evolving according to its dynamics and the control of a (in general) different controller:

$$\mathcal{C}^2 : \begin{cases} x_c^2(k+1) &= A_c^2 x_c^2(k) + B_c^2 e^2(k), \\ \pi^1(k) &= C_c^2 x_c^2(k) + D_c^2 e^2(k), \end{cases} \quad (21)$$

where the error signal considers the filtered state of the first side of the two-sided market:

$$e^2(k) = u^2(k) + \hat{y}^1(k) \quad (22)$$

Likewise, there is the filter for the second side of the two-sided market:

$$\mathcal{F}^2 : \begin{cases} x_f^2(k+1) &= A_f^2 x_f^2(k) + B_f^2 y(k), \\ \hat{y}^2(k) &= C_f^2 x_f^2(k). \end{cases} \quad (23)$$

Theorem 9. *Consider the feedback system depicted in Figure 1, with $\mathcal{C}^1, \mathcal{C}^2$ and $\mathcal{F}^1, \mathcal{F}^2$ given in (17, 21, 19, and 23), respectively. Assume that each agent $i \in \{1, \dots, N\}$ has its state x_i with dynamics governed by the affine stochastic difference equations given in (16 and 20), where A_i^1, A_i^2 are Schur matrices and b_i^1, b_i^2 and d_i^1, d_i^2 are chosen, at each time step, from the sets $\{b_{ij}^1, b_{ij}^2\} \subset \mathbb{R}^{n_i}$ and $\{d_{i\ell}^1, d_{i\ell}^2\} \subset \mathbb{R}^{n_i}$ according to Dini continuous probability functions $p_{ij}^1(\cdot), p_{ij}^2(\cdot)$, respectively $p_{i\ell}^1(\cdot), p_{i\ell}^2(\cdot)$, that verify (6). Assume furthermore that there are scalars $\delta^1, \delta^2, \delta'^1, \delta'^2 > 0$ such that $p_{ij}^1(\pi) \geq \delta^1 > 0$, $p_{ij}^2(\pi) \geq \delta^2 > 0$, $p_{ij}^1(\pi) \geq \delta'^1 > 0$, $p_{ij}^2(\pi) \geq \delta'^2 > 0$ for all (i, j) and all $\pi^1 \in \Pi^1, \pi^2 \in \Pi^2$. Then, for any stable linear controllers $\mathcal{C}^1, \mathcal{C}^2$ and any stable linear filters $\mathcal{F}^1, \mathcal{F}^2$ compatible with the system structure, the feedback loop converges in distribution to a unique invariant measure.*

Proof. Following [55], the proof is centred on the construction of an iterated function system (IFS) with place-(state-

)dependent probabilities that describes the feedback system. To this end, consider the augmented state

$$\xi := \begin{bmatrix} (x_i^1)_{i=1}^{N_1} \\ (x_i^2)_{i=1}^{N_2} \\ x_f^1 \\ x_f^2 \\ x_c^1 \\ x_c^2 \end{bmatrix} \in \mathbb{X}_{\mathcal{G}^1} \times \mathbb{X}_{\mathcal{G}^2} \times \mathbb{X}_{\mathcal{F}^1} \times \mathbb{X}_{\mathcal{F}^2} \times \mathbb{X}_{\mathcal{C}^1} \times \mathbb{X}_{\mathcal{C}^2}, \quad (24)$$

whose dynamic behaviour is described by the difference equation

$$\xi(k+1) = \mathcal{W}_\ell(x) := \mathcal{A}\xi(k) + \beta_\ell, \quad (25)$$

where the β_ℓ is built from the combinations of the vectors b_{ij}^1, b_{ij}^2 , the scalars d_{ij}^1, d_{ij}^2 and other signals, and the block-matrix

$$\mathcal{A} := \begin{bmatrix} \hat{A}^1 & 0 & 0 & 0 & 0 & 0 \\ 0 & \hat{A}^2 & 0 & 0 & 0 & 0 \\ B_f^1 \mathbf{1}^T \hat{C}^1 & 0 & A_f^1 & 0 & 0 & 0 \\ 0 & B_f^2 \mathbf{1}^T \hat{C}^2 & 0 & A_f^2 & 0 & 0 \\ 0 & 0 & 0 & -B_c^1 C_f^2 & A_c^1 & 0 \\ 0 & 0 & B_c^2 C_f^1 & 0 & 0 & A_c^2 \end{bmatrix} \quad (26)$$

in which the blocks are,

$$\begin{aligned} \hat{A}^1 &:= \text{diag}(A_i^1), \hat{C}^1 := \text{diag}(c_i^{1\top}), \\ \hat{A}^2 &:= \text{diag}(A_i^2), \hat{C}^2 := \text{diag}(c_i^{2\top}). \end{aligned}$$

To apply Corollary 2.3 from [55], two observations must be made. First, note that each map \mathcal{W}_ℓ is chosen with probability $p_\ell(\pi) \geq \prod_{i=1}^N \delta_i > 0$ and thus these probabilities are bounded away from zero. Second, since \mathcal{A} is lower-triangular block-matrix it is easy to notice that the spectrum of \mathcal{A} i.e $\sigma(\mathcal{A})$ can be expressed as follows:

$$\sigma(\mathcal{A}) = \sigma(\hat{A}^1) \cup \sigma(\hat{A}^2) \cup \sigma(A_f^1) \cup \sigma(A_f^2) \cup \sigma(A_c^1) \cup \sigma(A_c^2)$$

and, by hypothesis, for all $1 \leq i \leq N$, A_i^1, A_i^2 are Schur matrices [59, 60, 61] and $A_f^1, A_f^2, A_c^1, A_c^2$ are Schur matrices as well, for any induced matrix norm there exists $m \in \mathbb{N}$ sufficiently large such that $\|\mathcal{A}^m\| < 1$. This provides the required average contractivity after m steps. The result then follows from [55]. The proof is complete. \square

Remark 10. Dini's condition on the probabilities may be replaced by simpler, more conservative assumptions, such as Lipschitz or Hölder conditions [55]. Also the requirement $p_{ij}(\pi) \geq \delta_i > 0$ in the theorem statement is not an artefact of our analysis, as $p_{ij}(\pi) = 0$ may lead to a non-ergodic behaviour.

Remark 11. As we have stressed that the existence of an attractive invariant measure is only a baseline ergodic property. Under mild but technical additional assumptions, it is possible to prove a geometric rate of convergence [32]. Under further assumptions, one can prove results concerning the "shape" of the unique invariant measure, where it exists, such as moment

bounds [56]. These would complement the present theorem.

Remark 12. In [10, Theorem 12], we assume that the feedback loop only consists of stable systems. This assumption may seem quite restrictive, but as shown in the examples, even marginal stability in one of its parts may lead to completely unpredictable results. As the result from [55] only requires contractivity on average, more general results are possible, but beyond the scope of the present paper. We also point out that each agent may have a local stabilising controller, as we are analysing the feedback loop from a macroscopic level.

Theorem 13. Consider the feedback system depicted in Figure 1. Assume that each agent $i \in \{1, \dots, N_1\}$ and $i \in \{1, \dots, N_2\}$ has a state governed by the non-linear iterated function system

$$x_i^1(k+1) = \mathcal{W}_{ij}^1(x_i^1(k)), \quad (27)$$

$$y_i^1(k) = \mathcal{H}_{ij}^1(x_i^1(k)), \quad (28)$$

and

$$x_i^2(k+1) = \mathcal{W}_{ij}^2(x_i^2(k)), \quad (29)$$

$$y_i^2(k) = \mathcal{H}_{ij}^2(x_i^2(k)), \quad (30)$$

where $\mathcal{W}_{ij}^1, \mathcal{H}_{ij}^1, \mathcal{W}_{ij}^2, \mathcal{H}_{ij}^2$ are globally Lipschitz-continuous functions with global Lipschitz constant $l_{ij}^1, l_{ij}^{1'}, l_{ij}^2, l_{ij}^{2'}$ resp. Assume we have Dini continuous probability functions $p_{ij}^1, p_{il}^{1'}, p_{ij}^2, p_{il}^{2'}$ so that the probabilistic laws (6) are satisfied. Assume furthermore that there are scalars $\delta^1, \delta^{1'}, \delta^2, \delta^{2'} > 0$ such that $p_{ij}^1(\pi) \geq \delta^1 > 0$, $p_{ij}^{1'}(\pi) \geq \delta^{1'} > 0$, $p_{ij}^2(\pi) \geq \delta^2 > 0$, $p_{ij}^{2'}(\pi) \geq \delta^{2'} > 0$ for all (i, j) . Furthermore, assume that the following contractivity condition holds: for all $1 \leq i \leq N_1, 1 \leq j \leq J_1, 1 \leq i \leq N_2, 1 \leq j \leq J_2: l_{ij}^1 < 1, l_{ij}^{1'} < 1$. Then, for every stable linear controller \mathcal{C}_1 and \mathcal{C}_2 and every stable linear filter \mathcal{F}_1 and \mathcal{F}_2 compatible with the feedback structure 1, the feedback loop has a unique attractive invariant measure. In particular, the system is uniquely ergodic.

Proof. Similarly to the proof of [10, Theorem 18] the assumptions on the Lipschitz constants and the the internal asymptotic stability of controller and filter guarantees that suitable iterates of the maps F_m are strict contractions. The result then follows again from Theorem 2.1 and Corollary 2.2 of [55]. \square

Remark 14. Notice that Lipschitz continuity can be rephrased in many ways. For instance, there is the QUAD condition [62], the sector condition, or, when restricted to convex functions, the bounded subgradient condition. The sector condition requires that there exist constants c_1 and c_2 such that the vector-valued functions $\mathcal{W}(x) := [\mathcal{W}_i(x)]$ and $\mathcal{H}(x) := [\mathcal{H}_i(x)]$ satisfy $\mathcal{W}(x)^T[\mathcal{W}(x) - c_1x] \leq 0$ and $\mathcal{H}(x)^T[\mathcal{H}(x) - c_2x] \leq 0$. The bounded subgradient condition requires the existence of constants c_3, c_4 , such that for a given norm $|\cdot|$, for all z, z' in the subdifferentials of \mathcal{W}, \mathcal{H} , respectively, at all points in the domains of the respective functions, we have that $|z| \leq c_3, |z'| \leq c_4$. Here the functions $\mathcal{W}(x), \mathcal{H}(x)$ are assumed to be convex with a non-empty subdifferential

throughout their domains, but not necessarily differentiable. The equivalence follows from basic convex analysis, e.g., as a corollary of Lemma 2.6 in [63].

Next, consider the case when the agents' actions are limited to a finite set. In this case, the Lipschitz conditions cannot be satisfied except in trivial cases. In this case we may use results in [64, 65] to obtain ergodicity results.

Let $[M]$ denote the set $\{1, 2, \dots, M\}$ and suppose, X_1, X_2, \dots, X_M be a partition of a metric space \mathbb{X} into a non-empty Borel subsets. Consider, for all $i \in [M]$, let

$$w_{i,1}, w_{i,2}, \dots, w_{i,L_i} : X_i \rightarrow \mathbb{X}$$

be a family of Borel maps such that for each $j \in [L_i]$, there exists $m \in [M]$ such that $w_{i,j}(X_i) \subseteq X_m$. Finally, for each $i \in [M]$, let

$$p_{i,1}, p_{i,2}, \dots, p_{i,L_i} : X_i \rightarrow (0, 1],$$

be a family of Borel measurable probability functions associated with the maps, and $\sum_{j=1}^{L_i} p_{i,j} = 1$ for all $x \in X_i$.

Definition 15. [64] We call $\mathcal{V} = \{1, 2, \dots, M\}$ the set of vertices and the subsets X_1, \dots, X_M are called vertex sets. Further, we call the set

$$\mathcal{E} = \{(i, m_i) : i \in [M], m_i \in [L_i]\}$$

the set of edges and use the following notations:

$$p_e := p_{i,m} \text{ and } w_e := w_{i,m} \text{ for } (i, m) \in \mathcal{E}.$$

The edge is provided with a direction (an arrow) by marking an initial vertex through the map

$$\begin{aligned} i : \mathcal{E} &\rightarrow \mathcal{V} \\ (j, m) &\mapsto j. \end{aligned}$$

The terminal vertex $t(j, m) \in \mathcal{V}$ of an edge $(j, m) \in \mathcal{E}$ is determined by the corresponding map through

$$t((j, m)) := s : \iff w_{j,m}(X_j) \subseteq X_s.$$

We call the quadruple $\mathcal{G} := (\mathcal{V}, \mathcal{E}, i, t)$ a directed multigraph or digraph. Let for each agent i the set \mathbb{A}_i is finite. Then $\mathbb{X}_S = \prod_{i=1}^N \mathbb{A}_i$ is also finite. Consider a directed graph $\mathcal{G} := (\mathbb{X}_S, E)$, where there is an arc between vertices representing $(x_i) \in \mathbb{X}_S$ and $(y_i) \in \mathbb{X}_S$ whenever there is a choice of maps \mathcal{W}_{ij} in (27) and (29).

Theorem 16. Consider the feedback system depicted in Figure 1. Assume that \mathbb{A}_i is finite for each i . Assume that each agent $i \in \{1, \dots, N_1\}$ and $i \in \{1, \dots, N_2\}$ has a state governed by the non-linear stochastic difference equations. Assume we have Dini continuous probability functions $p_{ij}^1, p_{il}^1, p_{ij}^2, p_{il}^2$ so that the probabilistic laws (6) are satisfied. Assume furthermore that there are scalars $\delta^1, \delta^{1'}, \delta^2, \delta^{2'} > 0$ such that $p_{ij}^1(\pi) \geq \delta^1 > 0$, $p_{ij}^1(\pi) \geq \delta^{1'} > 0$, $p_{ij}^2(\pi) \geq \delta^2 > 0$, $p_{ij}^2(\pi) \geq \delta^{2'} > 0$

for all (i, j) and all π . Then, for every stable linear controller \mathcal{C} and every stable linear filter \mathcal{F} the following holds:

If the graph $\mathcal{G} = (\mathbb{X}_S, E)$ is strongly connected, then there exists an invariant measure for the feedback loop. If in addition, the adjacency matrix of the graph is primitive, then the invariant measure is attractive and the system is uniquely ergodic.

Proof. This is a consequence of [65] and the observation that the necessary contractivity properties follow from the internal asymptotic stability of controller and filter. \square

We note that a simple condition for the primitivity of the graph $\mathcal{G} = (\mathbb{X}_S, E)$ is that for each agent the graph describing the possible transitions is primitive.

IV. A LARGE-SCALE INTERCONNECTION FOR ENSEMBLE SYSTEMS

As hinted at in Section I-B, many markets that are traditionally thought of as two-sided are multi-sided platforms [5, 6, 7]. In the example of Uber, one can also consider ‘‘fleet partners’’ (who are intermediaries for car manufacturers and car leasing providers) and taxi operators. Such interconnections can get rather complicated and we would like to capture these in a matrix, similarly to the adjacency matrix of a graph defining the graph.

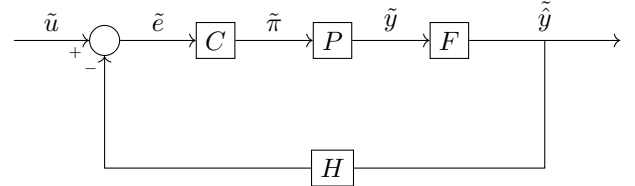

Fig. 2. Large-scale interconnection feedback model.

Building on the techniques of Section III, consider the interconnection of a multi-sided platform as described as follows:

$$e^p = u^p - \sum_{q=1}^M H_{pq} \hat{y}^q, \quad (31)$$

where e^p , for $p = 1, 2, \dots, M$, is the input to

$$\mathcal{C}^p : \begin{cases} x_c^p(k+1) &= A_c^p x_c^p(k) + B_c^p e^p(k), \\ \pi^p(k) &= C_c^p x_c^p(k) + D_c^p e^p(k), \end{cases} \quad (32)$$

u^p are external inputs, H_{pq} is a matrix with real and constant entries, and \hat{y}^q , for $q = 1, 2, \dots, M$, is the output of

$$\mathcal{F}^q : \begin{cases} x_f^q(k+1) &= A_f^q x_f^q(k) + B_f^q y^q(k), \\ \hat{y}^q(k) &= C_f^q x_f^q(k). \end{cases} \quad (33)$$

We also have, for $i = 1, 2, \dots, N_q$,

$$\mathcal{S}_i^q : \begin{cases} x_i^q(k+1) &= A_i^q x_i^q(k) + b_i^q, \\ y_i^q(k) &= c_i^{qT} x_i^q(k) + d_i^q, \end{cases} \quad (34)$$

where N_q is the total number of systems in the q th ensemble denoted by \mathcal{S}^q . Finally, $y^q(k) = y_1^q(k) + y_2^q(k) + \dots + y_{N_q}^q(k)$.

Now, by writing

$$\tilde{e} := \begin{bmatrix} e^1 \\ e^2 \\ \vdots \\ e^M \end{bmatrix}, \tilde{u} := \begin{bmatrix} u^1 \\ u^2 \\ \vdots \\ u^M \end{bmatrix}, \tilde{\pi} := \begin{bmatrix} \pi^1 \\ \pi^2 \\ \vdots \\ \pi^M \end{bmatrix}, \tilde{y} := \begin{bmatrix} y^1 \\ y^2 \\ \vdots \\ y^M \end{bmatrix}, \tilde{\hat{y}} := \begin{bmatrix} \hat{y}^1 \\ \hat{y}^2 \\ \vdots \\ \hat{y}^M \end{bmatrix} \quad (35)$$

the interconnection description may be expressed more compactly as

$$\tilde{e} = \tilde{u} - H\tilde{\hat{y}}, \quad (36)$$

where H is a matrix with block entries H_{pq} . Let $C := \text{diag}(\mathcal{C}^1, \dots, \mathcal{C}^M)$ such that $\tilde{\pi} = C\tilde{e}$, and $F := \text{diag}(\mathcal{F}^1, \dots, \mathcal{F}^M)$ such that $\tilde{\hat{y}} = F\tilde{y}$. This set-up is depicted in Figure 2. Then, similar to Theorem 9, we have the following result.

Theorem 17. *Consider the feedback system as described above and depicted in Figure 2. For each ensemble \mathcal{S}^q , $q = 1, 2, \dots, M$, assume that each i th system in the ensemble has its state x_i^q with dynamics governed by the affine stochastic difference equations given by (34), where A_i^q are Schur matrices, and b_i^q and d_i^q are chosen, at each time step, from sets according to Dini continuous probability functions in the manner of Theorem 9, and that these probability functions are bounded below by scalars strictly greater than 0. Then, for any stable linear controllers $\mathcal{C}^1, \dots, \mathcal{C}^M$ and any stable linear filters $\mathcal{F}^1, \dots, \mathcal{F}^M$ compatible with the system structure, the feedback loop converges in distribution to a unique invariant measure.*

Proof. In the spirit of Theorem 9, by defining an augmented state

$$\xi := \begin{bmatrix} \tilde{x} \\ \tilde{x}_f \\ \tilde{x}_c \end{bmatrix},$$

whose dynamic behaviour is described by the difference equation

$$\xi(k+1) = \mathcal{W}_\ell(x) := \mathcal{A}\xi(k) + \beta_\ell, \quad (37)$$

where

$$\tilde{x}_f := \begin{bmatrix} x_f^1 \\ x_f^2 \\ \vdots \\ x_f^M \end{bmatrix}, \tilde{x}_c := \begin{bmatrix} x_c^1 \\ x_c^2 \\ \vdots \\ x_c^M \end{bmatrix}, \tilde{x} := \begin{bmatrix} x^1 \\ x^2 \\ \vdots \\ x^M \end{bmatrix},$$

$$x^1 := \begin{bmatrix} x_1^1 \\ x_2^1 \\ \vdots \\ x_{N_1}^1 \end{bmatrix}, x^2 := \begin{bmatrix} x_1^2 \\ x_2^2 \\ \vdots \\ x_{N_2}^2 \end{bmatrix}, \dots, x^M := \begin{bmatrix} x_1^M \\ x_2^M \\ \vdots \\ x_{N_M}^M \end{bmatrix}.$$

We obtain

$$\mathcal{A} := \begin{bmatrix} \hat{A} & 0 & 0 \\ B_f \hat{\mathbf{1}} \hat{C} & A_f & 0 \\ 0 & -B_c H C_f & A_c \end{bmatrix}, \quad (38)$$

where,

$$\hat{\mathbf{1}} := [1 \ 1 \ \dots \ 1], \quad \hat{\mathbf{1}} := \text{diag}(\mathbf{1}^T),$$

$$\hat{A} := \text{diag}(A_1^1, \dots, A_{N_1}^1, A_1^2, \dots, A_{N_2}^2, \dots, A_1^M, \dots, A_{N_M}^M),$$

$$\hat{C} := \text{diag}(c_1^{1\top}, \dots, c_{N_1}^{1\top}, c_1^{2\top}, \dots, c_{N_2}^{2\top}, \dots, c_1^{M\top}, \dots, c_{N_M}^{M\top}),$$

$$A_f := \text{diag}(A_f^1, A_f^2, \dots, A_f^M), \quad B_f := \text{diag}(B_f^1, B_f^2, \dots, B_f^M),$$

$$C_f := \text{diag}(C_f^1, C_f^2, \dots, C_f^M), \quad A_c := \text{diag}(A_c^1, A_c^2, \dots, A_c^M),$$

$$B_c := \text{diag}(B_c^1, B_c^2, \dots, B_c^M)$$

The proof then follows in a manner similar to the proof of Theorem 9. \square

V. TIME DELAYS

Consider a scenario where a controller waits for a certain amount of jobs to come in before performing a matching of jobs to workers of any sort; that is, some buffering is performed. This, indeed, is the only practically relevant scenario: if the controller did not wait, then the matching would be performed on a greedy, first-come, first-served basis. This waiting time does, however, introduce a time delay.

In this section, we provide some mathematical discussion on time delays. Specifically, we describe a time delay scenario and offer some analysis on it. It is worth keeping in mind that there are additional ways in which a time delay scenario could be described.

Consider the linear discrete-time systems

$$\mathcal{S}_i : \begin{cases} x_i(k+1) &= A_i x_i(k) + \tilde{A}_i x_i(k-h) + b_i, \\ y_i(k) &= c_i^T x_i(k) + \tilde{c}_i^T x_i(k-h) + d_i, \end{cases} \quad (39)$$

for $i = 1, 2, \dots, N$, where A_i and \tilde{A}_i are Schur matrices and h is a constant delay. Expressing the first equation in (39), for example, in a more compact form gives

$$x(k+1) = \text{diag}(A_i)x(k) + \text{diag}(\tilde{A}_i)x(k-h) + b, \quad (40)$$

where

$$x := \begin{bmatrix} x_1 \\ x_2 \\ \vdots \\ x_N \end{bmatrix} \text{ and } b := \begin{bmatrix} b_1 \\ b_2 \\ \vdots \\ b_N \end{bmatrix}.$$

Following the technique described in Section 6.1 of [66], we can augment $x(k)$ by its finite history

$$x_{\text{aug}}(k) := \begin{bmatrix} x(k) \\ x(k-1) \\ \vdots \\ x(k-h) \end{bmatrix}$$

which, from (40), results in an augmented system without delay:

$$x_{\text{aug}}(k+1) = A_{\text{aug}}x_{\text{aug}}(k) + b_{\text{aug}},$$

where

$$A_{\text{aug}} := \begin{bmatrix} \text{diag}(A_i) & 0 & \cdots & \text{diag}(\tilde{A}_i) \\ I & 0 & \cdots & 0 \\ \vdots & \ddots & \ddots & \vdots \\ 0 & \cdots & I & 0 \end{bmatrix} \text{ and } b_{\text{aug}} := \begin{bmatrix} b \\ 0 \\ \vdots \\ 0 \end{bmatrix}.$$

Now, let us consider a simple feedback loop as depicted in Fig. 1 of [10]. Let

$$\xi_{\text{aug}} := \begin{bmatrix} x_{\text{aug}} \\ x_f \\ x_c \end{bmatrix}$$

where x_c and x_f are as described in (12) and (13), respectively, of [10]. The dynamic behaviour of ξ_{aug} is described by $\xi_{\text{aug}}(k+1) = \mathcal{A}_{\text{aug}}\xi_{\text{aug}}(k) + \beta_{\text{aug}}$, where

$$\mathcal{A}_{\text{aug}} := \begin{bmatrix} A_{\text{aug}} & 0 & 0 \\ B_f \mathbf{1}^T [c \ 0 \ \cdots \ 0 \ \tilde{c}] & A_f & 0 \\ 0 & -B_c C_f & A_c \end{bmatrix},$$

$$\beta_{\text{aug}} := \begin{bmatrix} b_{\text{aug}} \\ B_f \mathbf{1}^T d \\ B_c r \end{bmatrix}, \quad c := \begin{bmatrix} c_1^T \\ c_2^T \\ \vdots \\ c_N^T \end{bmatrix}, \quad \tilde{c} := \begin{bmatrix} \tilde{c}_1^T \\ \tilde{c}_2^T \\ \vdots \\ \tilde{c}_N^T \end{bmatrix}, \quad d := \begin{bmatrix} d_1 \\ d_2 \\ \vdots \\ d_N \end{bmatrix}$$

and r is the desired value of $y(k) = \sum_{i=1}^N y_i(k)$.

Definition 18 (Block-companion matrix,[67, 68]). *Consider the linear operators $B_i \in \mathcal{L}(\mathbb{R}^n, \mathbb{R}^n)$ for $i = 1, 2, \dots, n-1$ in the space of all linear operators $\mathcal{L}(\mathbb{R}^n, \mathbb{R}^n)$ and let $B := (B_0, B_1, \dots, B_{n-1})$. Consider the operator polynomial P_B as follows:*

$$P_B(\lambda) := \lambda^n I + \lambda^{n-1} B_{n-1} + \dots + \lambda B_1 + B_0, \quad \lambda \in \mathbb{C}.$$

The companion operator \mathfrak{C}^B of P_B is the $n \times n$ block operator matrix in the Hilbert space $\underbrace{\mathbb{R}^n \oplus \mathbb{R}^n \oplus \cdots \oplus \mathbb{R}^n}_{n \text{ copies}}$ given by

$$\mathfrak{C}^B = \begin{bmatrix} 0 & I_N & 0 & 0 & \cdots & 0 & 0 \\ 0 & 0 & I_N & 0 & 0 & 0 & 0 \\ 0 & 0 & 0 & I_N & 0 & 0 & 0 \\ \vdots & \vdots & \vdots & \vdots & \vdots & \vdots & \vdots \\ 0 & 0 & 0 & 0 & \cdots & I_N & 0 \\ 0 & 0 & 0 & 0 & 0 & 0 & I_N \\ -B_0 & -B_1 & \cdots & \cdots & \cdots & -B_{n-2} & -B_{n-1} \end{bmatrix} \quad (41)$$

Definition 19 ([69], p. 67). *A matrix $B \in \mathbb{R}^{n \times n}$ is said to be symmetrizable if there exists a symmetric-positive definite matrix $R = R^T \in \mathbb{R}^{n \times n}$ such that $B^T R = RB$.*

Definition 20 ([70, 71]). *Two matrices $B_1, B_2 \in \mathbb{R}^{n \times n}$ are said to be simultaneously symmetrizable if there exists a symmetric-positive definite matrix $R = R^T \in \mathbb{R}^{n \times n}$ such that $B_1^T R = RB_1$ and $B_2^T R = RB_2$.*

Theorem 21. *Suppose the following conditions are satisfied:*

$$(a) \quad \sigma(A_{\text{aug}}) \cap \sigma(-A_{\text{aug}}) = \emptyset,$$

$$(b) \quad \forall i, \left[\text{diag}(A_i) \right]_{\alpha} \left[\text{diag}(\tilde{A}_i) \right]_{\beta} \in \mathbb{R}^{n \times n}, \text{ with } 0 \leq \alpha \leq \beta \leq n, \text{ are simultaneously symmetrizable (Definition 20),}$$

then for any stable linear controllers $\mathcal{C}^1, \mathcal{C}^2$ and any stable linear filters $\mathcal{F}^1, \mathcal{F}^2$ compatible with the system structure, we have asymptotic stability of the system with constant delays (39), i.e., have all eigenvalues of \mathcal{A}_{aug} inside the unit circle.

Proof. First, notice that A_{aug} is a block companion matrix. The proof is based on the work of Martins et al. [72, 70] and the discrete-time Lyapunov stability theorem [73]. Proposition 2.1 of [72] (also reprinted as Proposition 2.2 in [70]) shows that under the conditions of the present theorem, for any symmetric positive definite matrix W , there exists a unique symmetric solution V of the Lyapunov matrix equation

$$A_{\text{aug}}^T V + V A_{\text{aug}} = -W. \quad (42)$$

Subsequently, the discrete-time Lyapunov stability theorem [74, Theorem 7.3.2] shows the asymptotic stability of

$$x(k+1) = A_{\text{aug}} x(k), \quad (43)$$

which in turn is equivalent [74, Theorem 7.3.1.] to the all the eigenvalues of A_{aug} being inside the unit circle. Consequently, all the eigenvalues of \mathcal{A}_{aug} are inside the unit circle since the other submatrices (A_f, A_c , etc) are Schur by the assumption of stability of the controllers and filters. \square

VI. NEGATIVE RESULTS FOR INTERCONNECTIONS OF MULTIPLE ENSEMBLES

It could be worth investigating in our context to determine the control strategies that destroy ergodicity of the closed-loop feedback system, or in other words, circumstances in which an attractive invariant measure fails to exist. In this scenario, coupling arguments may be used as they provide criteria for the non-existence of a unique invariant measure¹.

Consider the space of trajectories of a Σ -valued Markov chain $\{X(k)\}_{k \in \mathbb{N}}$, i.e., the space of all sequences $(x(0), x(1), x(2), \dots)$ with $x(k) \in \Sigma$, $k \in \mathbb{N}$, by Σ^∞ (the ‘‘path space’’). Recall, for example, that $P_\lambda \in \mathcal{M}(\Sigma^\infty)$ is the probability measure induced on the path space by the initial distribution λ of $X(0)$. A coupling of two probability measures $P_{\mu_1}, P_{\mu_2} \in \mathcal{M}(\Sigma^\infty)$ corresponding to two different initial distribution μ_1 and μ_2 , is a probability measure on $\Sigma^\infty \times \Sigma^\infty$ whose marginals coincide with P_{μ_1}, P_{μ_2} . To be precise, consider a probability measure Γ over the product of space $\mathcal{M}(\Sigma^\infty \times \Sigma^\infty)$. Γ can be projected to a measure over one or the other factor space Σ^∞ ; Let us denote this projections by $\Phi^{(1)}\Gamma$ and $\Phi^{(2)}\Gamma$. The set $\mathcal{C}_{\text{coup}}(P_{\mu_1}, P_{\mu_2})$ of couplings of $P_{\mu_1}, P_{\mu_2} \in \mathcal{M}(\Sigma^\infty)$ is then defined by

$$\mathcal{C}_{\text{coup}} = \left\{ \Gamma \in \mathcal{M}(\Sigma^\infty \times \Sigma^\infty) : \Phi^{(1)}\Gamma = P_{\mu_1}, \Phi^{(2)}\Gamma = P_{\mu_2} \right\}.$$

¹Coupling arguments have been used since the theorem of Harris [75, 76], and are hence sometimes known as Harris-type theorems. Generally, they link the existence of a coupling with the forgetfulness of initial conditions.

We say that a coupling $\Gamma \in \mathcal{C}_{\text{coup}}$ is an asymptotic coupling if Γ has full measure on the pairs of convergent sequences. To make this precise consider the set \mathcal{H} defined by:

$$\left\{ (x(k), z(k)) \in \Sigma^\infty \times \Sigma^\infty : \lim_{k \rightarrow \infty} \|x(k) - z(k)\| = 0 \right\}.$$

Γ is an asymptotic coupling if $\Gamma(\mathcal{H}) = 1$. The following statement is a specialization of [24, Theorem 1.1] to our situation:

Theorem 22 ([24]). *Consider an IFS with associated Markov operator P admitting two ergodic invariant measures μ_1 and μ_2 . The following are equivalent:*

- (i) $\mu_1 = \mu_2$.
- (ii) *There exists an asymptotic coupling of P_{μ_1} and P_{μ_2} .*

Consequently, if no asymptotic coupling of P_{μ_1} and P_{μ_2} exists, then μ_1 and μ_2 are distinct.

The existence of asymptotic couplings can then be ruled out with ease for certain controllers. For example, the Proportional-Integral (PI) controller can, in its simplest form [77, 78], be cast as:

$$\pi(k) = \pi(k-1) + \kappa[e(k) - \alpha e(k-1)], \quad (44)$$

where we omit the superscript indices for brevity. Consequently, the transfer function from e to π is

$$C(z) := \frac{\pi(z)}{e(z)} = \kappa \frac{1 - \alpha z^{-1}}{1 - z^{-1}}. \quad (45)$$

This utilizes the well-known \mathcal{Z} -transform to convert a discrete-time signal into its complex frequency-domain representation.

Proposition 23. *Consider the feedback system depicted in Figure 1 on the right, with $\mathcal{C}^1, \mathcal{C}^2$ and $\mathcal{F}^1, \mathcal{F}^2$ given in (17, 21, 19, and 23). Assume that each agent $i \in \{1, \dots, N\}$ has its state x_i with dynamics governed by the affine stochastic difference equations given in (16 and 20), where A_i^1, A_i^2 are Schur matrices and b_i^1, b_i^2 and d_i^1, d_i^2 are chosen, at each time step, from the sets $\{b_{ij}^1\} \subset \mathbb{R}^{n_i^1}$ and $\{d_{i\ell}^1, d_{i\ell}^2\} \subset \mathbb{R}^{n_i^2}$ according to Dini continuous probability functions $p_{ij}^1(\cdot), p_{ij}^2(\cdot)$, respectively $p_{i\ell}^1(\cdot), p_{i\ell}^2(\cdot)$, that verify (6). When at least one of the following conditions is not satisfied, the system cannot be uniquely ergodic:*

- (1) *there are two distinct ergodic measures;*
- (2) *there is no asymptotic coupling of P_{μ_1} and P_{μ_2} ;*
- (3) *one of the controllers \mathcal{C}^i is proportional-integral (44), while there is no delay;*
- (4) *one of the controllers \mathcal{C}^i has a pole on the unit circle, i.e., at $z = 1$ in (45), while there is no delay;*

Proof. The equivalence of the first two conditions follows from Theorem 22. The third and fourth conditions follow from the structure of \mathcal{A} (26) and Theorem 6 of [10]. \square

Remark 24. *Notice that the fourth condition seemingly restricts the applications of PI controllers in this space [79],*

where a cascaded PI control has been considered, e.g., for the control of internal combustion engines such that the overall pollution is regulated, cf. Table 1.1 in [80]. On the other hand, the situation may be substantially more complicated, when time delays are considered, cf. Section V.

Remark 25. *Notice that the fourth condition can be readily used to reason about, e.g., multiplicative surge pricing at Uber. While it is not incentive-compatible beyond the single-state model [17], the fourth condition suggests that it is not uniquely ergodic and hence not fair in the sense that the individuals' outcomes are independent of the initial state. To see this, consider a linearization of the multiplicative surge pricing, which would not be asymptotically stable. This may have been a motivation beyond the switch to additive surge pricing ².*

VII. RELATED WORK

Within Economics, Jean Tirole's pioneering research [1, 2, 3, 4] on two-sided markets has a substantial following [12]. Especially multi-sided platforms [5, 6, 7] and networked markets [23] became widespread both in economic theory and the real world.

Within Economics and Computation, much attention has been focussed on ride-hailing. When workers cannot reject jobs, dynamic pricing cannot outperform the optimal static policy in terms of throughput and revenue. It is known [17] that additive increases provide an incentive-compatible pricing mechanism, while certain complications arise [81] from the spatio-temporal nature of the problem. Motivated by Uber's own admission [82] that its prices are unfair to female and ethnic minority drivers, there has recently been some interest in studying fairness in related settings [83, 84, 85, 86], often using concept established in fairness [87, 88] in machine learning more broadly.

Related work also appears in the context of multi-agent systems [89]. Multi-agent systems arise, for instance, in the application areas stated above, and many references in the literature address these problems using ideas based on consensus or agreement [90, 91]. The consensus approach is very useful in practice, due to its strong links to utility maximization and fairness. The concept of fairness can be related to ergodicity, as an ergodic dynamic behaviour implies several important properties that are necessary for fairness [92]. Finally, we note that our positive results in this paper are based on iterated function systems [25, 26, 27]. Iterated function systems (IFS), albeit not well known, are a convenient and rich class of Markov processes. The class of stochastic systems arising from the dynamics of multi-agent interactions can be modelled and analysed using IFS in a particularly natural way. A wealth of results [25, 55, 27, 49, 35, 44, 32, 56, 57, 31, 58, 37] then applies.

VIII. CONCLUSIONS AND FURTHER WORK

Within feedback systems, the control of ensembles of agents presents a particularly challenging area for further study.

²<https://www.uber.com/blog/your-questions-about-the-new-surge-answered/>

Practically important examples of such systems arise in on-line labour platform. Typically, such problems deviate from classical control problems in two main ways. First, even though ensembles are typically too large to allow for a microscopic approach, they are not sufficiently large to allow for a meaningful fluid (mean-field) approximation. Second, the regulation problem concerns not only the ensemble, but also the individual agents; a certain quality of service should be provided to each agent. We have formulated this problem as an iterated function system with the objective of designing an ergodic control, and demonstrated that controls with poles on the unit circle (e.g., PI) may destroy ergodicity even for benign ensembles.

IX. ACKNOWLEDGEMENT

The work of Ramen and Bob was in part supported by Science Foundation Ireland grant 16/IA/4610. Jakub acknowledges support of the OP RDE funded project CZ.02.1.01/0.0/0.0/16_019/0000765 “Research Center for Informatics”.

REFERENCES

- [1] J.-C. Rochet and J. Tirole, “Platform Competition in Two-Sided Markets,” *Journal of the European Economic Association*, vol. 1, no. 4, pp. 990–1029, 06 2003.
- [2] —, “Defining two-sided markets,” Citeseer, Tech. Rep., 2004.
- [3] —, “Two-sided markets: an overview,” *Institut d’Economie Industrielle working paper*, 2004.
- [4] —, “Two-sided markets: a progress report,” *The RAND journal of economics*, vol. 37, no. 3, pp. 645–667, 2006.
- [5] E. G. Weyl, “A price theory of multi-sided platforms,” *American Economic Review*, vol. 100, no. 4, pp. 1642–72, September 2010. [Online]. Available: <https://www.aeaweb.org/articles?id=10.1257/aer.100.4.1642>
- [6] A. Hagiu and J. Wright, “Multi-sided platforms,” *International Journal of Industrial Organization*, vol. 43, pp. 162–174, 2015.
- [7] D. S. Evans and R. Schmalensee, *Matchmakers: The new economics of multisided platforms*. Harvard Business Review Press, 2016.
- [8] G. Parker, M. W. Van Alstyne, and X. Jiang, “Platform ecosystems: How developers invert the firm,” *MIS Quarterly*, vol. 41, no. 1, pp. 255–266, 2016.
- [9] T. Lundy, A. Wei, H. Fu, S. D. Kominers, and K. Leyton-Brown, “Allocation for social good: Auditing mechanisms for utility maximization,” in *Proceedings of the 2019 ACM Conference on Economics and Computation*, ser. EC ’19. New York, NY, USA: Association for Computing Machinery, 2019, p. 785–803. [Online]. Available: <https://doi.org/10.1145/3328526.3329623>
- [10] A. R. Fioravanti, J. Marecek, R. N. Shorten, M. Souza, and F. R. Wirth, “On the ergodic control of ensembles,” *Automatica*, vol. 108, p. 108483, 2019.
- [11] M. H. Bateni, Y. Chen, D. F. Ciocan, and V. Mirrokni, “Fair resource allocation in a volatile marketplace,” in *Proceedings of the 2016 ACM Conference on Economics and Computation*, ser. EC ’16. New York, NY, USA: Association for Computing Machinery, 2016, p. 819. [Online]. Available: <https://doi.org/10.1145/2940716.2940763>
- [12] I. Lobel, “Revenue management and the rise of the algorithmic economy,” *Management Science*, 2020.
- [13] M. K. Chen, “Dynamic pricing in a labor market: Surge pricing and flexible work on the uber platform,” in *Proceedings of the 2016 ACM Conference on Economics and Computation*, ser. EC ’16. New York, NY, USA: Association for Computing Machinery, 2016, p. 455. [Online]. Available: <https://doi.org/10.1145/2940716.2940798>
- [14] J. C. Castillo, D. Knoepfle, and G. Weyl, “Surge pricing solves the wild goose chase,” in *Proceedings of the 2017 ACM Conference on Economics and Computation*, 2017, pp. 241–242.
- [15] G. P. Cachon, K. M. Daniels, and R. Lobel, “The role of surge pricing on a service platform with self-scheduling capacity,” *Manufacturing & Service Operations Management*, vol. 19, no. 3, pp. 368–384, 2017.
- [16] J. C. Castillo, “Who benefits from surge pricing?” Available at SSRN 3245533, 2020.
- [17] N. Garg and H. Nazerzadeh, “Driver surge pricing,” in *Proceedings of the 21st ACM Conference on Economics and Computation*, ser. EC ’20. New York, NY, USA: Association for Computing Machinery, 2020, p. 501. [Online]. Available: <https://doi.org/10.1145/3391403.3399476>
- [18] A. Simonetto, J. Monteil, and C. Gambella, “Real-time city-scale ridesharing via linear assignment problems,” *Transportation Research Part C: Emerging Technologies*, vol. 101, pp. 208 – 232, 2019.
- [19] V. F. Araman, A. Calmon, and K. Fridgeirsdottir, “Pricing and job allocation in online labor platforms,” *INSEAD Working Paper No. 2019/32/TOM*, 2019.
- [20] A. Aouad and Ö. Sarıtaç, “Dynamic stochastic matching under limited time,” in *Proceedings of the 21st ACM Conference on Economics and Computation*, 2020, pp. 789–790.
- [21] E. Özkan, “Joint pricing and matching in ride-sharing systems,” *European Journal of Operational Research*, vol. 287, no. 3, pp. 1149–1160, 2020.
- [22] C. Yan, H. Zhu, N. Korolko, and D. Woodard, “Dynamic pricing and matching in ride-hailing platforms,” *Naval Research Logistics (NRL)*, vol. 67, no. 8, pp. 705–724, 2020.
- [23] G. G. Parker, M. W. Van Alstyne, and S. P. Choudary, *Platform revolution: How networked markets are transforming the economy and how to make them work for you*. WW Norton & Company, 2016.
- [24] M. Hairer, J. C. Mattingly, and M. Scheutzow, “Asymptotic coupling and a general form of Harris’ theorem with applications to stochastic delay equations,” *Probability*

- Theory and Related Fields, vol. 149, no. 1-2, pp. 223–259, 2011.
- [25] J. H. Elton, “An ergodic theorem for iterated maps,” Ergodic Theory and Dynamical Systems, vol. 7, no. 04, pp. 481–488, 1987.
- [26] M. F. Barnsley and J. H. Elton, “A new class of markov processes for image encoding,” Advances in applied probability, vol. 20, no. 1, pp. 14–32, 1988.
- [27] M. F. Barnsley, J. H. Elton, and D. P. Hardin, “Recurrent iterated function systems,” Constructive approximation, vol. 5, no. 1, pp. 3–31, 1989.
- [28] A. Schlote, F. Häusler, T. Hecker, A. Bergmann, E. Crisostomi, I. Radusch, and R. Shorten, “Cooperative regulation and trading of emissions using plug-in hybrid vehicles,” IEEE Transactions on Intelligent Transportation Systems, vol. 14, no. 4, pp. 1572–1585, 2013.
- [29] A. Schlote, C. King, E. Crisostomi, and R. Shorten, “Delay-tolerant stochastic algorithms for parking space assignment,” IEEE Transactions on Intelligent Transportation Systems, vol. 15, no. 5, pp. 1922–1935, Oct 2014.
- [30] J. Marecek, R. Shorten, and J. Y. Yu, “Signaling and obfuscation for congestion control,” International Journal of Control, vol. 88, no. 10, pp. 2086–2096, 2015.
- [31] P. Diaconis and D. Freedman, “Iterated random functions,” SIAM Review, vol. 41, no. 1, pp. 45–76, 1999.
- [32] D. Steinsaltz, “Locally contractive iterated function systems,” Ann. Probab., vol. 27, no. 4, pp. 1952–1979, 10 1999.
- [33] Ö. Stenflo, Ergodic theorems for time-dependent random iteration of functions. University of Umeå, Department of Mathematics, 1998.
- [34] —, “Ergodic theorems for iterated function systems controlled by stochastic sequences,” PhD thesis, 1999.
- [35] —, “Markov chains in random environments and random iterated function systems,” Transactions of the American Mathematical Society, vol. 353, no. 9, pp. 3547–3562, 2001.
- [36] —, “A note on a theorem of karlin,” Statistics & probability letters, vol. 54, no. 2, pp. 183–187, 2001.
- [37] —, “A survey of average contractive iterated function systems,” Journal of Difference Equations and Applications, vol. 18, no. 8, pp. 1355–1380, 2012.
- [38] T. Szarek, “Iterated function systems depending on previous transformation,” Acta Mathematica, 03 1997.
- [39] —, “Generic properties of continuous iterated function systems,” Bulletin of the Polish Academy of Sciences. Mathematics, vol. 47, no. 1, pp. 77–89, 1999.
- [40] —, “Invariant measures for iterated function systems,” in Annales Polonici Mathematici 75(1), 01 2000.
- [41] —, “The stability of markov operators on polish spaces,” Studia Mathematica, vol. 143, 01 2000.
- [42] —, “Generic properties of learning systems,” in Annales Polonici Mathematici, vol. 73. Instytut Matematyczny Polskiej Akademii Nauk, 2000, pp. 93–103.
- [43] K. Horbacz and T. Szarek, “Continuous iterated function systems on polish spaces,” Bulletin of the Polish Academy of Sciences, Mathematics, vol. 49, 01 2001.
- [44] T. Szarek, “Invariant measures for markov operators with application to function systems,” Studia Mathematica, vol. 154, pp. 207–222, 01 2003.
- [45] —, “Invariant measures for non-expansive markov operators on polish spaces,” Dissertationes Mathematicae, vol. 415, pp. 1–62, 01 2003.
- [46] R. Ghosh, J. Marecek, and R. Shorten, “Iterated piecewise-stationary random functions,” arXiv preprint arXiv:1909.10093, 2019.
- [47] Y. Kifer, Ergodic theory of random transformations. Springer Science & Business Media, 2012, vol. 10.
- [48] R. N. Bhattacharya and E. C. Waymire, Stochastic processes with applications. SIAM, 2009.
- [49] M. Barnsley, Fractals Everywhere, ser. Dover books on mathematics. Dover Publications, 2013.
- [50] M. Corless, C. King, R. Shorten, and F. Wirth, AIMD Dynamics and Distributed Resource Allocation, ser. Advances in Design and Control. Society for Industrial and Applied Mathematics, 2016.
- [51] J. Marecek, R. Shorten, and J. Y. Yu, “r-extreme signalling for congestion control,” International Journal of Control, vol. 89, no. 10, pp. 1972–1984, 2016.
- [52] M. S. Branicky, “Stability of switched and hybrid systems,” in Proceedings of the 33rd IEEE Conference on Decision and Control, vol. 4, Dec 1994, pp. 3498–3503 vol.4.
- [53] —, “Multiple Lyapunov functions and other analysis tools for switched and hybrid systems,” IEEE Transactions on Automatic Control, vol. 43, no. 4, pp. 475–482, Apr 1998.
- [54] J. Epperlein and J. Marecek, “Resource allocation with population dynamics,” in 2017 55th Annual Allerton Conference on Communication, Control, and Computing (Allerton), Oct 2017, pp. 1293–1300.
- [55] M. F. Barnsley, S. G. Demko, J. H. Elton, and J. S. Geronimo, “Invariant measures for markov processes arising from iterated function systems with place-dependent probabilities,” in Annales de l’IHP Probabilités et statistiques, vol. 24, 1988, pp. 367–394.
- [56] C. P. Walkden, “Invariance principles for iterated maps that contract on average,” Transactions of the American Mathematical Society, vol. 359, no. 3, pp. 1081–1097, 2007. [Online]. Available: <http://www.jstor.org/stable/20161616>
- [57] B. Bárány, “On iterated function systems with place-dependent probabilities,” Proc. Amer. Math. Soc., vol. 143, pp. 419–432, 2015.
- [58] M. Iosifescu, “Iterated function systems: A critical survey,” Math. Reports, vol. 11, no. 3, pp. 181–229, 2009.
- [59] J. Schur, “Über die gaußschen summen,” Nachrichten von der Gesellschaft der Wissenschaften zu Göttingen, Mathematisch-Physikalische Klasse, vol. 1921, pp. 147–153, 1921. [Online]. Available: <http://eudml.org/doc/59098>
- [60] R. L. Graham and D. H. Lehmer, “On the permanent of schur’s matrix,” Journal of the Australian Mathematical Society, vol. 21, no. 4, p. 487–497, 1976.

- [61] N. Bof, R. Carli, and L. Schenato, “Lyapunov theory for discrete time systems,” arXiv preprint arXiv:1809.05289, 2018.
- [62] P. DeLellis, M. di Bernardo, and G. Russo, “On QUAD, Lipschitz, and contracting vector fields for consensus and synchronization of networks,” IEEE Transactions on Circuits and Systems I: Regular Papers, vol. 58, no. 3, pp. 576–583, March 2011.
- [63] S. Shalev-Shwartz, “Online learning and online convex optimization,” Foundations and Trends® in Machine Learning, vol. 4, no. 2, pp. 107–194, 2012.
- [64] I. Werner, “Contractive Markov systems,” Journal of the London Mathematical Society, vol. 71, no. 1, pp. 236–258, 2005.
- [65] —, “Ergodic theorem for contractive Markov systems,” Nonlinearity, vol. 17, no. 6, pp. 2303–2313, 2004.
- [66] E. Fridman, A. Seuret, and J.-P. Richard, “Robust sampled-data stabilization of linear systems: an input delay approach,” Automatica, vol. 40, no. 8, pp. 1441–1446, August 2004.
- [67] C. Tretter, Spectral theory of block operator matrices and applications. World Scientific, 2008.
- [68] P. Lancaster and M. Tismenetsky, The theory of matrices: with applications. Elsevier, 1985.
- [69] R. Bellman, Introduction to matrix analysis. SIAM, 1997.
- [70] F. Martins, E. Pereira, M. A. F. Vicente, and J. Vitória, “Stability of matrix differential equations with commuting matrix constant coefficients,” in Mathematical Methods in Engineering, N. M. Fonseca Ferreira and J. A. Tenreiro Machado, Eds. Dordrecht: Springer Netherlands, 2014, pp. 97–107.
- [71] S. Adhikari, “On symmetrizable systems of second kind,” J. Appl. Mech., vol. 67, no. 4, pp. 797–802, 2000.
- [72] F. M. Pereira, “Block matrices and stability theory,” Tatra Mt. Math. Publ., vol. 38, pp. 147–162, 2007.
- [73] Z. Gajic and M. T. J. Qureshi, Lyapunov matrix equation in system stability and control. Courier Corporation, 2008.
- [74] B. Datta, Numerical methods for linear control systems. Academic Press, 2004, vol. 1.
- [75] T. E. Harris, “A lower bound for the critical probability in a certain percolation process,” Mathematical Proceedings of the Cambridge Philosophical Society, vol. 56, no. 1, pp. 13–20, 1960.
- [76] T. Lindvall, Lectures on the Coupling Method, ser. Dover Books on Mathematics. Dover Publications, 2012.
- [77] G. F. Franklin, J. D. Powell, and A. B. Emami-Naeini, Feedback Control of Dynamic Systems. Reading, MA: Addison Wesley, 1994.
- [78] G. F. Franklin, J. D. Powell, and M. L. Workman, Digital Control of Dynamic Systems, 3rd ed. Englewood Cliffs, NJ: Prentice Hall, 1997.
- [79] K. J. Åström and T. Häggglund, “The future of pid control,” Control engineering practice, vol. 9, no. 11, pp. 1163–1175, 2001.
- [80] P. Polteraer, “Emission aware ecodriving control,” Ph.D. dissertation, Universität Linz, 2019.
- [81] H. Ma, F. Fang, and D. C. Parkes, “Spatio-temporal pricing for ridesharing platforms,” ACM SIGecom Exchanges, vol. 18, no. 2, pp. 53–57, 2020.
- [82] C. Cook, R. Diamond, J. Hall, J. A. List, and P. Oyer, “The gender earnings gap in the gig economy: Evidence from over a million rideshare drivers,” National Bureau of Economic Research, Tech. Rep., 2018.
- [83] T. Sühr, A. J. Biega, M. Zehlike, K. P. Gummadi, and A. Chakraborty, “Two-sided fairness for repeated matchings in two-sided markets: A case study of a ride-hailing platform,” in Proceedings of the 25th ACM SIGKDD International Conference on Knowledge Discovery & Data Mining, 2019, pp. 3082–3092.
- [84] M. Cohen, A. N. Elmachtoub, and X. Lei, “Price discrimination with fairness constraints,” Available at SSRN 3459289, 2019.
- [85] C. Jung, S. Kannan, C. Lee, M. Pai, A. Roth, and R. Vohra, “Fair prediction with endogenous behavior,” in Proceedings of the 21st ACM Conference on Economics and Computation, ser. EC ’20. New York, NY, USA: Association for Computing Machinery, 2020, p. 677–678. [Online]. Available: <https://doi.org/10.1145/3391403.3399473>
- [86] R. Freeman, N. Shah, and R. Vaish, “Best of both worlds: Ex-ante and ex-post fairness in resource allocation,” in Proceedings of the 21st ACM Conference on Economics and Computation, ser. EC ’20. New York, NY, USA: Association for Computing Machinery, 2020, p. 21–22. [Online]. Available: <https://doi.org/10.1145/3391403.3399537>
- [87] A. Chouldechova and A. Roth, “A snapshot of the frontiers of fairness in machine learning,” Commun. ACM, vol. 63, no. 5, p. 82–89, Apr. 2020.
- [88] H. Mouzannar, M. I. Ohannessian, and N. Srebro, “From fair decision making to social equality,” in Proceedings of the Conference on Fairness, Accountability, and Transparency, 2019, pp. 359–368.
- [89] S. McArthur, E. Davidson, V. Catterson, A. Dimeas, N. Hatzigiorgyriou, F. Ponci, and T. Funabashi, “Multi-agent systems for power engineering applications — Part I: Concepts, approaches, and technical challenges,” IEEE Transactions on Power Systems, vol. 22, no. 4, pp. 1743–1752, Nov. 2007.
- [90] V. Blondel, J. Hendrickx, A. Olshevsky, and J. Tsitsiklis, “Convergence in multiagent coordination, consensus, and flocking,” in Proceedings of the 44th IEEE Conference on Decision and Control, and the European Control Conference 2005, Seville, Spain, Dec. 2005, pp. 2996–3000.
- [91] A. Nedić and A. Ozdaglar, “Distributed subgradient methods for multi-agent optimization,” IEEE Transactions on Automatic Control, vol. 54, no. 1, pp. 48–61, Jan. 2009.
- [92] G. Mathew and I. Mezić, “Metrics for ergodicity and design of ergodic dynamics for multi-agent systems,” Physica D, vol. 240, pp. 432–442, 2011, physica D.

APPENDIX

TABLE I: A Table of Notation

Symbol	Meaning
\mathbb{N}	the set of natural numbers
\mathbb{Z}	set of all integers
\mathbb{Q}	the set of rational numbers
\mathbb{R}	the set of real numbers
$\mathbf{1}$	a compatible vector of ones
c_1, \dots, c_4	constants used in Remark 14
h_i	the number of output maps \mathcal{H}_{ij}
l_{ij}	Lipschitz constant for a transition map
l'_{ij}	Lipschitz constant for an output map
N^1	the number of participants on one side of the market
N^2	the number of participants on the other side of the market
n	a dimension of a generic state space \mathbb{X}
n_c^1	dimension of the state of the controller
n_f^1	dimension of the state of the filter
n_c^2	dimension of the state of the controller
n_f^2	dimension of the state of the filter
n_i^1	dimension of the state of i th agent's private state
m_i^1	the number of possible actions of agent i
m	an upper bound on the number of possible actions of any agent
r^1	the reference value, i.e., desired value of $y^1(k)$
\bar{r}_i^1	i th agent's expected share of the resource over the long run
w_i	the number of state transition maps \mathcal{W}_{ij}
n_i^2	dimension of the state of i th agent's private state
m_i^2	the number of possible actions of agent i
m	an upper bound on the number of possible actions of any agent
r^2	the reference value, i.e., desired value of $y^1(k)$
\bar{r}_i^1	i th agent's expected share of the resource over the long run
w_i	the number of state transition maps \mathcal{W}_{ij}
z	\mathcal{L} -transform variable
α	a constant used in the PI controller or its lag approximant
β	a constant used in a lag controller
δ	a constant in the iterated function system ergodicity used in Theorem 8
δ'	a constant in the iterated function system ergodicity used in Theorem 8
η	a lower bound on the values of probability functions
κ	a constant used in the PI controller or its lag approximant
\mathcal{C}^1	controller representing the central authority
\mathcal{F}^1	filter
$\mathcal{S}_1^1, \mathcal{S}_2^1, \dots, \mathcal{S}_N^1$	systems modelling agents
\mathcal{C}^2	controller representing the central authority
\mathcal{F}^2	filter
$\mathcal{S}_1^2, \mathcal{S}_2^2, \dots, \mathcal{S}_N^2$	systems modelling agents
f_j	a generic map in a generic iterated function system
g	a generic function of
\mathcal{H}_{ij}	an output map
\mathcal{H}_c	a map modelling the controller in
\mathcal{H}_f	a map modelling the filter in
$P(x, \mathbb{G})$	a generic transition operator
P	a state-and-signal-to-state transition operator
\mathcal{P}_k	a measure-space-over-states-to-measure-space-over-states operator
p_j	a probability function of a generic iterated function system
p_{ij}	a probability function for the choice of agent i 's transition map

continues on next page

$p'_{i\ell}$	a probability function for the choice of agent i 's output map
\mathcal{W}_{ij}	transition maps
\mathcal{W}_c	maps modelling the controller in
\mathcal{W}_f	maps modelling the filter in
$\Phi^{(1)}$	projector from a measure over the product of the two path spaces to a single path space
$\Phi^{(2)}$	projector from a measure over the product of the two path spaces to a single path space
A_i	a matrix used in the agent dynamics of Theorem 21
A_c^1	a matrix used in the controller of Theorem 9
A_c^2	a matrix used in the controller of Theorem 9
B_c^1	a matrix used in the controller of Theorem 9
A_f^2	a matrix used in the filter of Theorem 9
B_c^2	a matrix used in the controller of Theorem 9
B_f^1	a matrix used in the filter of Theorem 9
B_i	a matrix used in the agent dynamics of Theorem
C_c^1	a matrix used in the controller of Theorem and in Theorem 9
B_f^2	a matrix used in the filter of Theorem 9
B_i	a matrix used in the agent dynamics of Theorem
C_c^2	a matrix used in the controller of Theorem and in Theorem 9.
C_f^1	a matrix used in the filter of Theorem 9
c_i^1	a vector used in the agent dynamics of Theorem
D_c^1	a matrix used in the controller of Theorem.
C_f^2	a matrix used in the filter of Theorem.
c_i^2	a vector used in the agent dynamics of Theorem
D_c^2	a matrix used in the controller of Theorem.
d_i^2	a vector used in the agent dynamics of.
$X(k)$	element of a generic state space
$\{X(k)\}_{k \in \mathbb{N}}$	a generic Markov chain
\mathcal{A}	augmented state transition matrix in
\hat{A}	$\text{diag}(A_i)$ in
β_ℓ	is built from all b_{ij} , d_{ij} , and other signals in
\hat{C}	$\text{diag}(c_i^T)$ in
E	edges of a graph in the proof of.
G	a graph in the proof of Theorem.
K	a constant used in the proof of.
Q	a scalar or matrix used in the proof.
R	a marginally Schur matrix used in the proof of.
A_i	the set of i th agent's actions
$\mathcal{C}_{\text{coup}}$	set of couplings
\mathbb{D}_i	set of possible resource demands of agent i
$\mathcal{B}(\mathbb{X})$	Borel σ -algebra
\mathcal{E}	a real additive group.
G	a generic event
\mathcal{H}	a set used in the definition of asymptotic couplings
J	index set of a generic iterated function system
M	an index set of
$\mathcal{M}(\mathbb{X})$	a measure-space over \mathbb{X}
$\mathcal{M}(\mathbb{X}^\infty)$	a measure space over the path space
$\mathbb{O}_{\mathcal{F}}$	set of possible output values of the filter \mathcal{F}
X_i	a private state space of agent i , often \mathbb{R}^{n_i}
X_S	a product space of state spaces of all agents
X_F^1	a space of internal states of the filter
X_C^1	a space of internal states of the central controller
\mathbb{X}	a state space of the controller, the filter, and the agents, combined
\mathbb{X}^∞	a path space

continues on next page

Π	the set of admissible broadcast control signals
$e^1(k)$	the error signal at time k , i.e., $\hat{y}^1(k) - r$
$\pi^1(k)$	the signal broadcast at time k
$x_c^1(k)$	the internal state of the controller at time k of dimension n_c^1
x_i^1	resource utilisation of agent i at time k
$y^1(k)$	the aggregate resource utilisation at time k
$\hat{y}^1(k)$	the value of $y^1(k)$ filtered by filter \mathcal{F}^1
λ	initial state (distribution)
P_λ	a probability measure induced on the path space
μ	a generic measure, usually on state space Σ
Γ	a generic measure over the product of the two path spaces, potentially a coupling
