

All You Need is DAG

IDIT KEIDAR, Technion

ELEFThERIOS KOKORIS-KOGIAS, IST Austria and Novi Research

ODED NAOR, Technion*

ALEXANDER SPIEGELMAN, Novi Research

We present *DAG-Rider*, the first asynchronous Byzantine Atomic Broadcast protocol that achieves optimal resilience, optimal amortized communication complexity, and optimal time complexity. *DAG-Rider* is post-quantum safe and ensures that all messages proposed by correct processes eventually get decided. We construct *DAG-Rider* in two layers: In the first layer, processes reliably broadcast their proposals and build a structured Directed Acyclic Graph (DAG) of the communication among them. In the second layer, processes locally observe their DAGs and totally order all proposals with no extra communication.

1 INTRODUCTION

The amplified need in scalable geo-replicated Byzantine fault-tolerant reliability systems has motivated an enormous amount of study on the Byzantine State Machine Replication (SMR) problem [17, 31]. Many variants of the problem were defined in recent years [28, 32, 43] to capture the needs of blockchain systems. To address the fairness issues that naturally arise in interorganizational deployments, we focus on the classic long-lived Byzantine Atomic Broadcast (BAB) problem [13, 19], which in addition to total order, progress, and validity, guarantees *eventual fairness*. That is, *all* proposals by correct processes are eventually included.

Up until recently, asynchronous protocols for the Byzantine consensus problem [13, 16, 26] have been considered too costly or complicated to be used in practical SMR solutions. However, two recent single-shot Byzantine consensus papers, VABA [1] and later Dumbo [35], presented asynchronous solutions with (1) optimal resilience, (2) expected constant time complexity, and (3) optimal quadratic communication and optimal amortized linear communication complexity (for the latter). In this paper, we follow this recent line of work and present *DAG-Rider*: the first asynchronous BAB protocol with optimal resilience, optimal round complexity, and optimal amortized communication complexity. In addition, given a perfect shared coin abstraction, our protocol does not use signatures and does not rely on asymmetric cryptographic assumptions. Therefore, when using a deterministic threshold-based coin implementation with an information theoretical agreement guarantee [14, 34], the safety properties of our BAB protocol are post-quantum secure.

Overview. We construct *DAG-Rider* in two layers: a communication layer and a zero-overhead ordering layer. In the communication layer, processes reliably broadcast their proposals with some meta-data that help them form a *Directed Acyclic Graph (DAG)* of the messages they deliver. That is, the DAG consists of rounds s.t. every process broadcasts at most one message in every round and every message has $O(n)$ references to messages in previous rounds, where n is the total number of processes. The ordering layer does not require any extra communication. Instead, processes observe their local DAGs and with the help of a little randomization (one coin flip per $O(n)$ decisions on values proposed by different processes) locally order all the delivered messages in their local DAGs.

A nice feature of *DAG-Rider* is that the propose operation is simply a single reliable broadcast. The agreement property of the reliable broadcast ensures that all correct processes eventually see the same DAG. Moreover, the Validity

*Part of the work done while at Novi Research.

	Communication Complexity	Expected time Complexity	Post-Quantum Safety	Eventual Fairness
VABA SMR	$O(n^2)$	$O(\log(n))$	no	no
Dumbo SMR	amortized $O(n)$	$O(\log(n))$	no	no
DAG-Rider + [11]	amortized $O(n^2)$	$O(1)$	yes	yes
DAG-Rider + [25]	amortized $O(n \log(n))$	$O\left(\frac{\log(n)}{\log(\log(n))}\right)$	yes	$(1-\epsilon)$ -fair
DAG-Rider + [15]	amortized $O(n)$	$O(1)$	yes	yes

Table 1. A comparison between our protocol with different reliable broadcast instantiations and VABA and Dumbo based SMR protocols.

property of the reliable broadcast guarantees that all broadcast messages by correct processes are eventually included in the DAG. As a result, in contrast to the VABA and Dumbo protocols that retroactively ignore half the protocol messages and commit one value out of $O(n)$ proposals, DAG-Rider does not waste any of the messages and all proposed values by correct processes are eventually ordered (i.e., there is no need to re-propose).

Complexity. We measure time complexity as the asynchronous time [16] required to commit $O(n)$ values proposed by different correct processes, and we measure communication complexity by the number of bits processes send to commit a single value. To compare DAG-Rider to the state-of-the-art asynchronous Byzantine agreement protocols, we consider SMR implementations that run an unbounded sequence of the VABA or Dumbo protocols to independently agree on every slot. To compare apples to apples in respect to our time complexity definition, we allow VABA and Dumbo based SMRs to run up to n slots concurrently. Note, however, that to satisfy external validity (e.g., no double spend) processes must output the slot decisions in a sequential order (no gaps). Therefore, based on the proof in [6], the time complexity of VABA and Dumbo based SMRs is $O(\log(n))$. Table 1 compares DAG-Rider to VABA and Dumbo based SMRs.

Since our protocol uses a reliable broadcast abstraction as a basic building block, different instantiations yield different complexity. For example, if we use the classic Bracha broadcast [11] to propose a single value in each message, we get a communication complexity of $O(n^3)$ per decision. This is because the Bracha broadcast complexity is $O(n^2)$, and in order to form a DAG each message has to include an $O(n)$ references to previous messages. If we are willing to allow a probability ϵ to violate progress, then we can use Guerraoui et al.’s broadcast protocol [25] and reduce the complexity to $O(n^2 \log(n))$ per decision.

Now, just as Dumbo amortizes VABA’s communication complexity from quadratic to linear by using batching and adding a phase of erasure coding to more economically distribute the data, we can amortize our communication complexity to be linear per decision as well. First, since we are anyway including a vector of $O(n)$ references in every broadcast, batching $O(n)$ proposals in each message shaves a factor of n of the total communication complexity even with Bracha broadcast. To arrive at the optimal linear complexity, we can replace the reliable broadcast with the asynchronous verifiable information dispersal of Cachin and Tessaro [15]. The communication complexity of that protocol is $O(n^2 \log(n) + n|V|)$, where $|V|$ is the message size, which allows us to batch $O(n \log(n))$ proposals to achieve optimal amortized communication complexity.

A final feature of our protocol, which is sometimes underestimated and cannot be presented in a table, is elegance: (1) DAG-Rider’s modularity clearly separates the communication layer from the ordering logic; (2) the reliable broadcast

abstraction's different instantiations yield protocols with different trade-offs, and; (3) the entire detailed pseudocode of the ordering logic spans less than 30 lines.

The rest of this paper is structured as follows: §2 describes the model and the building blocks used for DAG-Rider; §3 formally defines the BAB problem; §4 describes the DAG construction layer; §5 specifies the DAG-Rider protocol on top of the DAG layer; §6 proves the correctness of the protocol and analyzes its performance; §7 describes related work; and lastly, §8 concludes the paper.

2 MODEL AND BUILDING BLOCKS

The system consists of a set $\Pi = \{p_1, \dots, p_n\}$ of n processes, up to $f < n/3$ of which can act arbitrarily, i.e., be *Byzantine*. For simplicity, we consider a total of $n = 3f + 1$ processes. The link between every two correct processes is reliable. Namely, when a correct process sends a message to another correct process, the message eventually arrives and the recipient can verify the sender's identity. The communication is asynchronous, i.e., there is no bound on the message delivery time.

We consider an adaptive adversary that can dynamically corrupt up to f processes during the run. Once the adversary corrupts a process, it can drop undelivered messages previously sent from that process to others. The adversary controls the arrival times of messages.

As part of the construction, we use two building blocks: a reliable broadcast layer and a delayed global perfect coin, which we describe next.

Reliable broadcast. We use a *reliable broadcast* [12] abstraction: Each sender process p_k can send messages by calling $r_bcast_k(m, r)$, where m is a message, $r \in \mathbb{N}$ is a round number. Every process p_i has an output $deliver_i(m, r, p_k)$, where m is a message, r is a round number, and p_k is the process that called the corresponding $r_bcast_k(m, r)$. The reliable broadcast abstraction guarantees the following properties:

Agreement If a correct process p_i outputs $deliver_i(m, r, p_k)$, then every other correct process p_j eventually outputs $deliver_j(m, r, p_k)$.

Integrity For each round $r \in \mathbb{N}$ and process $p_k \in \Pi$, a correct process p_i outputs $deliver_i(m, r, p_k)$ at most once.

Validity If a correct process p_k calls $r_bcast_k(m, r)$, then every correct process p_i eventually outputs $deliver_i(m, r, k)$.

There are known algorithms such as Bracha broadcast [11] to realize the reliable broadcast abstraction in the asynchronous network model. There are also efficient gossip protocols [9, 10, 25, 27] that provide reliable broadcast whp at a sub-quadratic communication cost in the number of processes, and asynchronous verifiable information dispersal protocols [15, 35] that use erasure codes to efficiently batch the broadcast values.

Global perfect coin. We use a *global perfect coin*, which is unpredictable by the adversary. An instance w , $w \in \mathbb{N}$, of the coin is invoked by process $p_i \in \Pi$ by calling $choose_leader_i(w)$. This call returns a process $p_j \in \Pi$, which is the chosen leader for instance w . Let X_w be the random variable that represents the probability that the coin returns process p_j as the return value of the call $choose_leader_i(w)$. The global perfect coin has the following guarantees:

Agreement If two correct processes call $choose_leader_i(w)$ and $choose_leader_j(w)$ with respective return values p_1 and p_2 , then $p_1 = p_2$.

Termination If at least $f + 1$ processes call $choose_leader(w)$, then every $choose_leader(w)$ call eventually returns.

Unpredictability As long as less than $f + 1$ processes call $choose_leader(w)$, the return value is indistinguishable from a random value except with negligible probability ϵ . Namely, the probability pr that the adversary can guess the returned process p_j of the call $choose_leader(w)$ is $pr \leq \Pr[X_w = p_j] + \epsilon$.

Fairness The coin is fair, i.e., $\forall w \in \mathbb{N}, \forall p_j \in \Pi: \Pr[X_w = p_j] = 1/n$.

Such coins were used as part of previous Byzantine Agreement protocols such as [1, 7, 14, 35]. Implementation examples can be found in [14, 34]. One way to implement a global perfect coin is by using PKI and a threshold signature scheme [8, 33, 42] with a threshold of $(f + 1)$ -of- n . When a process invokes an instance w of the coin, it signs w with its private key and sends the share to all the processes. Once a process receives $f + 1$ shares, it can combine them to get the threshold signature and hash it to get a random process. Since the threshold signature value is deterministically determined by the instance name w such that any $f + 1$ shares reveal it (e.g., the schema in [42] is based on Shamir's secret sharing [41]), the coin is perfect (all process agree on the leader) and its agreement property has information theoretical guarantee. However, to ensure unpredictability, the PKI must be trusted to ensure that the adversary cannot generate enough shares to reveal the randomness before a correct process produces them. Usually, one assumes that a trusted dealer is used to set up the random keys for all processes. However, this assumption can be relaxed by executing an $O(n^4)$ message complexity Asynchronous Distributed Key Generation protocol [30]. Either way, this scheme remains unpredictable only if the adversary is computationally bounded. However, since DAG-Rider relies on the unpredictability property of the coin only for liveness, its safety properties are post-quantum secure.

3 PROBLEM DEFINITION

The problem we solve is *Byzantine Atomic Broadcast (BAB)*, which allows processes to agree on a sequence of messages as needed for State Machine Replication (SMR). To capture the practical settings of a system, we require *external validity* [13], whereby a well-known predicate $validate(tx) \in \{\text{True}, \text{False}\}$ returns true if and only if a transaction tx is eligible to be included in the SMR. For instance, in a blockchain system that is used to log payments between users, a transaction is valid if there is no double-spending and the signature is correct. We say that a value v is *valid* if $validate(v)$ returns true.

Due to the FLP result [23], BAB cannot be solved deterministically in the asynchronous setting, and therefore we use the global perfect coin to provide randomness that ensures liveness with probability 1.

Atomic broadcast is usually defined in terms of broadcast and deliver events. To avoid confusion with the events of the underlying reliable broadcast abstraction, we rename those actions *propose* and *decide*.

Definition 3.1 (Byzantine Atomic Broadcast). Each correct process $p_i \in \Pi$ can call $propose_i(v)$ and output $decide_i(\ell, v)$, $\ell \in \mathbb{N}$. We say that p_i *proposes* a value v when $propose_i(v)$ is called, and *decides* v in slot ℓ when $decide_i(\ell, v)$ is output.

An Atomic Broadcast protocol provides the following guarantees:

Eventual Fairness If a correct process proposes a valid value v , then all correct processes eventually decide v with probability 1.

External validity If a correct process decides v , then $validate(v) = \text{True}$.

Termination If a correct process decides in slot ℓ , then all correct processes eventually decide in slot ℓ with probability 1.

Agreement If two correct processes p_i, p_j decide values v_1, v_2 , respectively in the same slot ℓ , then $v_1 = v_2$.

Integrity For a single slot number ℓ , a correct process p_i decides at most one value v .

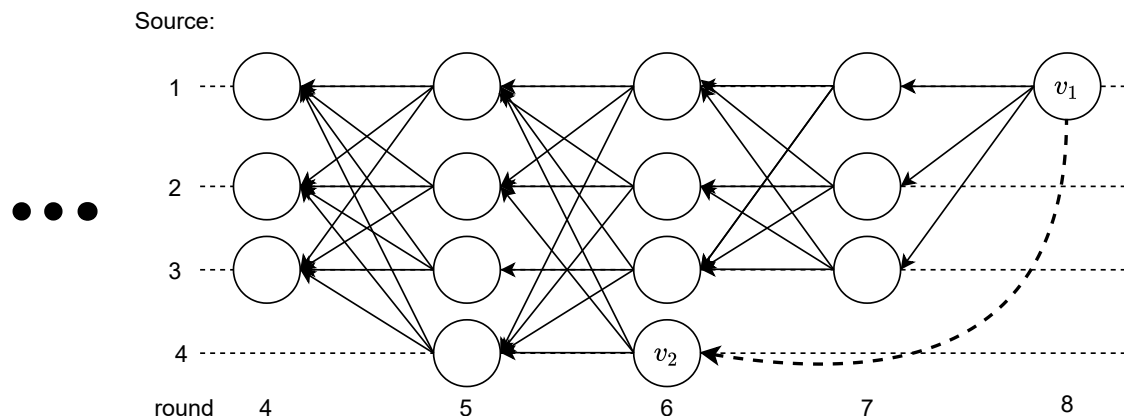

Fig. 1. **Illustration of the DAG structure at process 1.** Strong edges are illustrated as *solid* black arrows, the weak edge is illustrated as the *dotted* arrow.

Note that the Eventual Fairness property requires that if a correct process proposes a valid value v , then eventually v gets decided. In contrast, many Byzantine State Machine Replication (SMR) protocols [17, 37, 43] require that in an infinite run, an infinite number of decisions are made, but not every proposed valid value has to be decided.

Communication measurement. For the communication analysis, we say that a value v is *ordered* when all honest parties decide v . We measure *communication complexity* as the total number of bits sent by honest processes to order a single proposal. To be able to measure the asynchronous running time we follow [16] and define a *time unit* for every execution r to be the maximum time delay of all messages among correct processes in r . We measure *time complexity* as the expected number of time units it takes for a correct party to decide on $O(n)$ values proposed by different correct processes starting from any point in the execution.

4 DAG ABSTRACTION

Our BAB protocol, DAG-Rider, is based on a Directed Acyclic Graph (DAG) abstraction, which represents the communication layer of the processes. In a nutshell, each vertex in the DAG represents a message from a process, and each message contains, among other data, references to previously broadcast vertices. Those references are the edges of the DAG. All messages are reliably broadcast and each correct process maintains a copy of the DAG as it perceives it. Different correct processes might observe different states of the DAG during different times of the run, but the reliable broadcast prevents equivocation and guarantees that all correct processes eventually deliver the same messages, so their views of the DAG eventually converge.

For each process p_i , denote p_i 's local view of the DAG as DAG_i , which is stored as an array $DAG_i[\cdot]$. As we shortly explain, each vertex in the DAG is associated with a unique round number and a source (its generating process). At any given time, $DAG_i[r]$ for $r \in \mathbb{N}$ is the set of all the vertices associated with round r that p_i is aware of. Each round has at most n vertices, each with a different source. Due to the reliable broadcast, no process can generate two vertices in the same round.

Each vertex v in a round r has two sets of outgoing edges: a set of at least $2f + 1$ *strong edges* and a set of up to f *weak edges*. Strong edges point to vertices in round $r - 1$ and weak edges point to vertices in rounds $r' < r - 1$ such

Algorithm 1 Data structures and basic utilities for process p_i

Local variables:

struct *vertex* v : ▷ The struct of a vertex in the DAG

$v.round$ - the round of v in the DAG

$v.source$ - the process that broadcast v

$v.block$ - a block of transactions

$v.strongEdges$ - a set of vertices in $v.round - 1$ that represent *strong* edges

$v.weakEdges$ - a set of vertices in rounds $< v.round - 1$ that represent *weak* edges

$DAG[]$ - An array of sets of vertices, initially:

$DAG_i[0] \leftarrow$ predefined hardcoded set of $2f + 1$ vertices

$\forall j \geq 1: DAG_i[j] \leftarrow \{\}$

$blocksToPropose$ - A queue, initially empty, p_i enqueues valid blocks of transactions from clients

1: **procedure** $path(v, u)$ ▷ Check if exists a path consisting of strong and weak edges in the DAG

2: **return** exists a sequence of $k \in \mathbb{N}$, vertices v_1, v_2, \dots, v_k s.t.

$v_1 = v, v_k = u$, and $\forall i \in [2..k]: v_i \in \bigcup_{r \geq 1} DAG_i[r] \wedge (v_i \in v_{i-1}.weakEdges \cup v_{i-1}.strongEdges)$

3: **procedure** $strong_path(v, u)$ ▷ Check if exists a path consisting of only strong edges in the DAG

4: **return** exists a sequence of $k \in \mathbb{N}$, vertices v_1, v_2, \dots, v_k s.t.

$v_1 = v, v_k = u$, and $\forall i \in [2..k]: v_i \in \bigcup_{r \geq 1} DAG_i[r] \wedge v_i \in v_{i-1}.strongEdges$

that otherwise there is no path from v to them. As explained in detail in §5, strong edges are used for agreement and weak edges make sure we eventually include all vertices in the decision, to satisfy the Eventual Fairness property of the BAB problem.

The data types and variables for process p_i are specified in Algorithm 1 and the DAG construction is specified in Algorithm 2. A vertex v is a struct that holds a round number r , a source which is the process that created v , a block of valid transactions that were previously proposed by the upper BAB protocol, strong edges to at least $2f + 1$ vertices in round $r - 1$, and weak edges to vertices in rounds $r' < r - 1$. Vertices in the DAG are reliably broadcast (Line 14), and when the reliable broadcast layer delivers a vertex v (Line 20), it uses the round number r and the source process which are available from the reliable broadcast and adds them to v , and then calls the *is_valid_vertex* procedure (Line 25) to verify that the transactions that v holds are externally valid and that v has strong edges to at least $2f + 1$ vertices from round $r - 1$. If v passes the check, it is added to a buffer.

The process p_i continuously goes through the buffer to check if there is a vertex v in it that can be added to its DAG_i (Line 6). A vertex v can be added to the DAG once the DAG contains all the vertices that v has a strong or weak edge to (Line 7). When p_i has at least $2f + 1$ vertices in the current round r , it moves to the next round $r + 1$ (Line 9) by creating and reliably broadcasting a new vertex v' . The new vertex v' includes a block of transactions for which p_i previously invoked propose (can be empty), strong edges to the vertices in $DAG_i[r]$ (Line 15), and weak edges to any vertices with no path from v' to them (Line 27). Note that a vertex might be delivered at p_i 's DAG after p_i has moved to a later round. In this case, the vertex is still added to the DAG, but p_i 's vertices do not include strong edges to it. Weak edges are possible. As noted, the weak edges are used to ensure the eventual fairness property of the BAB problem.

An example of our DAG construction is illustrated in Fig. 1. The DAG in the example represents DAG_1 , i.e., the DAG at process 1, out of a total of four processes, numbered 1 to 4. On each horizontal dotted line are the vertices from a single source, e.g., the bottom line shows the vertices delivered from process 4. Each vertical column of vertices is a single round. Each completed round has at least $2f + 1 = 3$ vertices. Each vertex in the DAG has at least $2f + 1$ strong edges to vertices from the previous round shown as black solid arrows. Each vertex can also have weak edges to

Algorithm 2 DAG Construction, pseudocode for process p_i

Local variables:

$r \leftarrow 0$ ▷ round number
 $buffer \leftarrow \{\}$

5: **while** True **do**

6: **for** $v \in buffer$: $v.round \leq r$ **do**

7: **if** $\forall v' \in v.strongEdges \cup v.weakEdges$: $v' \in \bigcup_{k \geq 1} DAG[k]$ **then** ▷ We have v 's predecessors

8: $DAG[v.round] \leftarrow DAG[v.round] \cup \{v\}$

9: **if** $|DAG[r]| \geq 2f + 1$ **then** ▷ Start a new round

10: **if** $r \bmod 4 = 0$ **then** ▷ If a new wave is complete

11: $wave_ready(r/4)$ ▷ Signal to Algorithm 3 that a new wave is complete

12: $r \leftarrow r + 1$

13: $v \leftarrow create_new_vertex(r)$

14: $r_bcast_i(v, r)$

15: **procedure** $create_new_vertex(round)$

16: $v.block \leftarrow blocksToPropose.dequeue()$ ▷ Returns \perp if the queue is empty. Proposed blocks are enqueued (Line 32)

17: $v.strongEdges \leftarrow DAG[round - 1]$

18: $set_weak_edges(v, round)$

19: **return** v

20: **upon** $deliver_i(v, round, p_k)$ **do** ▷ The deliver output from the reliable broadcast

21: $v.source \leftarrow p_k$

22: $v.round \leftarrow round$

23: **if** $is_valid_vertex(v)$ **then**

24: $buffer \leftarrow buffer \cup \{v\}$

25: **procedure** $is_valid_vertex(v)$

26: **return** $|v.strongEdges| \geq 2f + 1 \wedge \forall tx \in v.block$: $validate(tx)$ ▷ $validate(tx)$ checks external validity

27: **procedure** $set_weak_edges(v, round)$ ▷ Add weak edges to orphan vertices

28: $v.weakEdges \leftarrow \{\}$

29: **for** $r = round - 2$ down to 1 **do**

30: **for every** $u \in DAG_i[r]$ s.t. $\neg path(v, u)$ **do**

31: $v.weakEdges \leftarrow v.weakEdges \cup \{u\}$

vertices in case there is no other path in the DAG to the vertex. E.g., v_1 in the illustration has a weak edge to v_2 , shown as a dotted arrow to v_2 .

5 DAG-RIDER: DAG-BASED ASYNCHRONOUS BAB PROTOCOL

In this section, we describe the DAG-Rider protocol, by equipping the DAG from the previous section with a global perfect coin¹ and show how the DAG and the coin can be used to construct a locally-computed protocol for the BAB problem. That is, given our DAG and a perfect coin, DAG-Rider does not require any extra communication among the processes. Instead, each process p_i observes its local DAG_i and deduces which blocks of transactions to decide and in what order. The protocol is detailed in Algorithm 3. Below we give a high-level intuition as well as a detailed description of the protocol and in §6 we analyze complexity and prove the correctness of the full protocol.

When a $propose_i(v)$ is invoked, p_i simply pushes v to the DAG layer (line 33), which in turn includes it in a vertex it reliably broadcasts. To interpret the DAG, each process p_i divides its local DAG_i into waves, where each wave consists

¹A possible implementation of the coin using threshold signatures is described in §2. The coin can be easily implemented as part of the DAG itself by having each process send its share of the threshold signature when reliably broadcasting a vertex.

Algorithm 3 DAG-Rider: Byzantine Atomic Broadcast based on DAG. Pseudocode for process p_i

Local Variables:
 $slot \leftarrow 1$
 $decidedWave \leftarrow 0$
 $decidedVertices \leftarrow \{\}$
 $leadersStack \leftarrow$ initialize empty stack with isEmpty(), push(), and pop() functions

32: **upon** $propose_i(b)$ **do** ▷ The propose call of the BAB problem
 33: $blocksToPropose.enqueue(b)$ ▷ pushes a block of transactions to Alg 2

34: **upon** $wave_ready(w)$ **do** ▷ Signal from the DAG layer that a new wave is completed (Line 11)
 35: $v \leftarrow get_wave_vertex_leader(w)$
 36: **if** $v = \perp \vee |\{v' \in DAG_i[round(w, 4)]: strong_path(v', v)\}| < 2f + 1$ **then** ▷ No commit
 37: **return**
 38: $leadersStack.push(v)$
 39: **for** wave w' from $w - 1$ down to $decidedWave + 1$ **do**
 40: $v' \leftarrow get_wave_vertex_leader(w')$
 41: **if** $v' \neq \perp \wedge strong_path(v, v')$ **then**
 42: $leadersStack.push(v')$
 43: $v \leftarrow v'$
 44: $decidedWave \leftarrow w$
 45: $order_vertices(leadersStack)$

46: **procedure** $get_wave_vertex_leader(w)$
 47: $p_j \leftarrow choose_leader_i(w)$
 48: **if** $\exists v \in DAG[round(w, 1)]$ s.t. $v.source = p_j$ **then**
 49: **return** v ▷ There can only be one such vertex
 50: **return** \perp

51: **procedure** $order_vertices(leadersStack)$
 52: **while** $\neg leadersStack.isEmpty()$ **do**
 53: $v \leftarrow leadersStack.pop()$
 54: $verticesToDecide \leftarrow \{v' \in \bigcup_{r>0} DAG_i[r] \mid path(v, v') \wedge v' \notin decidedVertices\}$
 55: **for every** $v' \in verticesToDecide$ in some deterministic order **do**
 56: $decide_i(slot, v'.block)$
 57: $slot \leftarrow slot + 1$
 58: $decidedVertices \leftarrow decidedVertices \cup \{v'\}$

of 4 consecutive rounds. For example, p_i 's first wave consists of $DAG_i[1]$, $DAG_i[2]$, $DAG_i[3]$, and $DAG_i[4]$. Formally, the k -th round of wave w , where $k \in [1..4]$, $w \in \mathbb{N}$, is defined as $round(w, k) \triangleq 4(w - 1) + k$. We also say that a process p_i *completes round r* once $DAG_i[r]$ has at least $2f + 1$ vertices, and a process *completes wave w* once the process completes $round(w, 4)$.

In a nutshell, the idea is to interpret the DAG as a wave-by-wave protocol and try to *commit* a randomly chosen single leader vertex in every wave. Once the sequence of leaders is determined, processes decide on all the blocks included in their causal histories. While reading the high-level description below, bear in mind that due to the reliable broadcast, Byzantine processes cannot equivocate, so two correct processes cannot have different vertices with the same source in the same round, leading to eventually consistent DAGs among all correct processes.

When wave w completes (Line 34), we use the global perfect coin to retrospectively elect some process and consider its vertex in the wave's first round as the leader of wave w (Line 35). The goal of the protocol is to commit this leader, provided that it has been observed by sufficiently many processes in the wave. Note that since we advance rounds as soon as we deliver $2f + 1$ of the $3f + 1$ potential vertices, a process p_i might not have w 's leader in its local DAG_i when

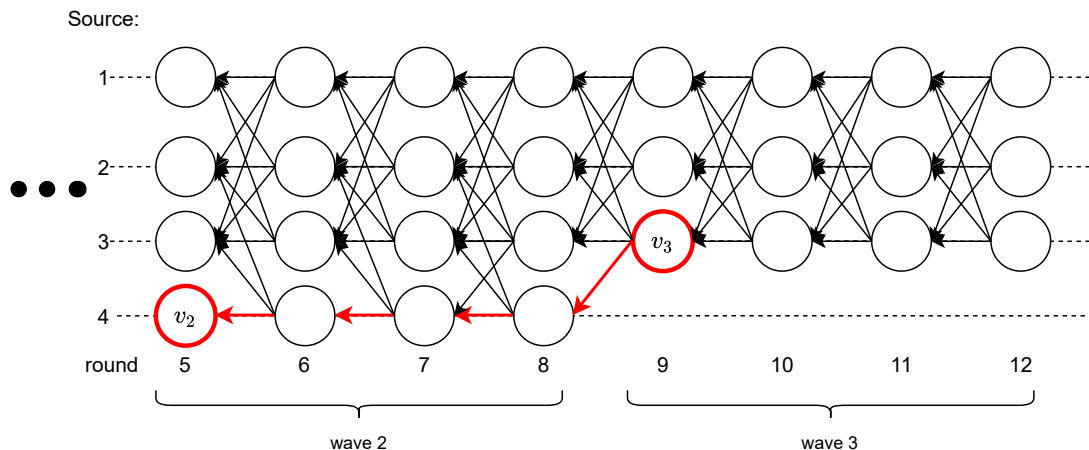

Fig. 2. **Illustration of DAG_i .** The highlighted vertices v_2 and v_3 are the leaders of waves 2 and 3, respectively. The commit rule is not met in wave 2 since there are less than $2f + 1$ vertices in round 8 with a strong path to v_2 . However, the commit rule is met in wave 3 since there are $2f + 1$ vertices in round 12 with a strong path to v_3 . Since there is a strong path from v_3 to v_2 (highlighted), p_i commits v_2 before v_3 in wave 3.

it completes w . In this case, p_i completes w without committing any vertex and simply proceeds to the next wave. Note, however, that some other correct process might have w 's leader in its local DAG and commit it in the same wave. Thus, we need to make sure that if one correct process commits the wave vertex leader v , then all the other correct processes will commit v later. To this end, we use standard quorum intersection. Process p_i commits the wave w vertex leader v if:

$$|\{v' \in DAG_i[round(w, 4)] : strong_path(v', v)\}| \geq 2f + 1 \text{ (Line 36).}$$

In addition, if p_i commits vertex v in wave w and there is a strong path from v to v' such that v' is an uncommitted leader vertex in a wave $w' < w$, then p_i commits v' in w as well. The leaders committed in the same wave are ordered by their round numbers, so that leaders of earlier waves are ordered before those of later ones, meaning v' is ordered before v (Lines 39-43).

The next lemma, which we formally prove in §6, shows that our commit rule guarantees that if a correct process commits a wave leader vertex v in some wave, then all wave vertex leaders in later waves in the local DAGs of all correct processes have a strong path to v , ensuring the agreement property.

Lemma 1. *If some process p_i commits the leader vertex v of a wave w , then for every leader vertex u of a wave $w' > w$ and for every process p_j , if $u \in DAG_j[round(w', 1)]$, then $strong_path(u, v)$ returns true in wave w' .*

We show below how we leverage the above lemma to satisfy the agreement property, but first, we give an intuition for liveness, i.e., the Eventual Fairness and Termination properties. Our protocol achieves progress in a constant number of waves, in expectation, by guaranteeing that for every wave, the probability for every correct process to commit the wave leader is at least $2/3$. To ensure this, we borrow the technique from the *common-core abstraction* [2], which guarantees that after three rounds of all-to-all sending and collecting accumulated sets of values, all correct processes have at least $2f + 1$ common values. The set of these values is referred to as the common-core. In respect to our DAG, we prove in §6 the following lemma:

Lemma 2. *Let p_i be a correct process that completes wave w . Then there is a set $V \subseteq DAG_i[\text{round}(w, 1)]$ and a set $U \subseteq DAG_i[\text{round}(w, 4)]$ s.t. $|V| \geq 2f + 1$, $|U| \geq 2f + 1$ and $\forall v \in V, \forall u \in U : \text{strong_path}(u, v)$.*

Note that by the commit rule, if the leader of a wave w belongs to the set V (from the lemma statement), then p_i commits the leader once it completes w . So to deal with an adversary that totally controls the network, parties flip the global coin only after they complete w (Line 35). Therefore, by the coin’s unpredictability property, the probability of the adversary to guess the wave’s leader before the point after which it cannot manipulate the set V is less than $\frac{1}{n} + \epsilon$. Thus, with a probability of at least $2/3 - \epsilon$, w ’s leader is in the set V and p_i commits it. Thus, in expectation, correct processes commit every $3/2$ waves.

To satisfy agreement, we leverage the property proven in Lemma 1 to make sure all processes commit the same waves’ leaders. Once we find a leader to commit in a wave w we check if it is possible that some process committed a wave in between w and the previous wave we committed, let it be w' . We do this iteratively in Lines 39-43, we first check if it is possible that some process committed the leader of $w - 1$. We do it by checking if there is a strong path from the leader of wave w to the leader of wave $w - 1$ in our local DAG (Line 41). If no such path exists, by Lemma 1, no correct process will ever commit $w - 1$. Otherwise, we choose to commit $w - 1$ before w . Now, if such a path indeed exists, we recursively check if it is possible that some process committed a wave in between $w - 1$ and w' . Otherwise, if no such path exists, we check if there is a path from the leader of wave w to the leader of wave $w - 2$ and continue in the same way. The recursion ends once we reach a wave that we previously committed, w' in our example. An illustration of this process is given in Fig. 2.

Since vertices are reliably broadcast and since we never add a vertex v to the DAG before we add all the vertices v points to with strong or weak edges, two correct processes always have the same causal history for any vertex they both have in their DAGs. Therefore, once we agree on a sequence of leaders, all that is left to do is to order the causal histories of the leaders in some deterministic order. To this end, we go through the waves’ committed leaders one-by-one and decide, in some deterministic order, on all the transaction blocks in their causal histories that we did not previously decide on (Procedure *order_vertices* in Line 51). The causal history of a wave leader vertex v in DAG_i is the set $\{u \in DAG_i \mid \text{path}(v, u)\}$.

The purpose of the weak edges is to satisfy the Eventual Fairness property. Recall that strong edges might not point to all vertices from the previous round in the DAG because we might advance the round before we deliver all the broadcasts of that round (we advance the round once at least $2f + 1$ vertices are added to the DAG). Therefore, without the weak edges, slow processes may not be able to get vertices from higher rounds to point to theirs. So to satisfy Eventual Fairness, each correct process, when creating a new vertex, adds weak edges to all vertices in its local DAG to which it otherwise does not point.

6 ANALYSIS

In §6.1 we prove the correctness of DAG-Rider, and in §6.2 we analyze the communication the time complexity.

6.1 Correctness

We show that DAG-Rider achieves the properties of the BAB problem, as defined in §3.

Lemma 3. *DAG-Rider achieves the integrity property of the BAB problem.*

PROOF. When a correct process p_i decides on a block in a slot number ℓ (Line 56) it increases by one the *slot* variable in the next line, so that next time p_i decides on a block, it will be in slot number $\ell + 1$, ensuring that p_i does not decide on more than one block in a single slot number. \square

Lemma 4. *DAG-Rider achieves the external validity property of the BAB problem.*

PROOF. A vertex v is added to the DAG_i of process p_i only after p_i checks if all transactions in $v.block$ pass the external validity predicate (Line 25). Since p_i decides only on blocks in vertices that are in its DAG, then any decision made is on an externally valid block of transactions. \square

Claim 1. *When a correct process p_i adds a vertex v to its DAG_i (Line 8), all of v 's causal history is already in DAG_i .*

PROOF. We prove this claim by induction on the execution of every correct process p_i . Denote by v_k the k -th vertex that p_i adds to DAG_i . We show that for every $k \in \mathbb{N}$, after v_k is added to the DAG, the causal histories of all the vertices in the set $\{v_1, \dots, v_k\}$, and in particular v_k , are in DAG_i .

In the base step of the induction, there are no vertices in the DAG, and the property vacuously holds. Next, assume that after v_k is added to the DAG at process p_i , all the causal histories of all the vertices in the set $V = \{v_1, \dots, v_k\}$ are already in DAG_i .

For v_{k+1} to be added to the DAG at process p_i , its strong and weak edges must reference vertices that are already in DAG_i (Line 7), i.e., v_{k+1} 's edges are only to vertices in V . Since all the vertices in V already have their causal histories in the DAG, when v_{k+1} is added to the DAG, its causal history is in the DAG as well, and we are done. \square

Claim 2. *If a correct process p_i adds a vertex v to its DAG_i , then eventually all correct processes add v to their DAG.*

PROOF. By induction on rounds, for process p_i to add a vertex v in round r to its DAG_i , first v needs to be delivered to p_i by the reliable broadcast layer (Line 20), and by the agreement of the reliable broadcast, v will be eventually delivered to all other correct processes.

Next, v has to be added to the *buffer* variable at p_i , and this is done if the process who broadcast v added the correct $v.source$ and $v.round$ which are verified through the guarantees of the reliable broadcast layer (Line 23). Therefore these checks will also pass at any other correct process when v is delivered to it. Vertex v also has to pass the *isValidVertex* procedure (Line 25), which ensures that the proposed block of transactions passes the external validity condition, as well as that the block references at least $2f + 1$ vertices from round $v.round - 1$. If v passes the two checks in p_i then it will pass these two checks at any other correct process, since these checks are computed locally based on v 's fields ($v.block$ and $v.strongEdges$).

Lastly, after v is added to the *buffer*, for p_i to add v to its DAG_i , p_i also checks that it has all the vertices that v is referencing to (in $V = v.strongEdges \cup v.weakEdges$) in its DAG_i as well (Line 7). By the induction assumption, all correct processes' DAGs contain the same vertices in rounds $< r$.

Thus, this ensures that any vertex v that appears in any round at DAG_i of some correct process, will eventually also appear in DAG_j of every other correct process p_j . \square

Claim 3. *If for some correct process p_i there is a round r with a set V of at least $2f + 1$ vertices in $DAG_i[r]$ s.t. $\forall v \in V$: $strong_path(v, u)$ to some vertex $u \in DAG_i$, then every other process p_j that completes round r has a set $V' \subseteq DAG_j[r]$ s.t. $|V'| \geq f + 1$ and $\forall v' \in V'$: $strong_path(v', u)$.*

PROOF. Let $V' = V \cap DAG_j[r]$. Round r is complete for p_i and p_j when their DAGs have at least $2f + 1$ vertices. Therefore, when p_i and p_j complete round r , $|V'| \geq f + 1$ by a standard quorum intersection of $2f + 1$ out of $3f + 1$

possible vertices of round r (due to the reliable broadcast, Byzantine processes cannot equivocate). Since every $v' \in V'$ is already in DAG_j when p_j completes round r , then u is in DAG_j by t as well (by Claim 1), and there is a strong path between every $v' \in V'$ to u in DAG_j . \square

For the next part, we say a process *commits* a wave leader vertex v when v is popped from the stack in Line 53.

Claim 4. *In every wave, at most one vertex v can be a wave leader vertex for all correct processes.*

PROOF. For a vertex v to be a wave leader vertex in wave w it has to be the return value from the `get_wave_vertex_leader` procedure (Line 46). The procedure gets the wave's chosen process p_j by the global coin, and checks if the DAG_i at process p_i has the vertex v from p_j in the first round of wave w . Due to the agreement property of the global perfect coin, the same process p_j is chosen for all correct processes, and because of the agreement property of the reliable broadcast, Byzantine processes cannot equivocate. \square

Claim 5. *If a correct process p_i commits wave leader vertex v_1 in wave w_1 and after that p_i commits vertex v_2 in wave w_2 , then $w_1 < w_2$.*

PROOF. A vertex is committed when it is popped from the stack (Line 53). Vertices are pushed to the stack in Lines 38 and 42, which only happens in waves which vertices were not committed before, since the for loop goes down only to `decidedWave + 1` (Line 39), where `decidedWave` is updated each time vertices are pushed to the stack to be the maximum wave in which vertices were committed (Line 44). This means that vertices are pushed to the stack in decreasing wave numbers.

Lastly, all the vertices in the stack are popped out and committed, and this is done in reverse order to the order that they were pushed to the stack, therefore, the wave numbers of committed waves are in an increasing order. \square

Lemma 5. *If some process p_i commits the leader vertex v of a wave w , then for every leader vertex u of a wave $w' > w$ and for every process p_j , if $u \in DAG_j[\text{round}(w', 1)]$, then `strong_path(u, v)` returns true in wave w' .*

PROOF. Since vertex v is committed by process p_i in wave w , the commit rule is met, i.e., at the end of wave w there are at least $2f + 1$ vertices in $DAG_i[\text{round}(w, 4)]$ with a strong path to v . By Claim 3, every correct process p_j (whether it commits v in w or not) has a set V of at least $f + 1$ vertices in $DAG_j[\text{round}(w, 4)]$ with a strong path to v . Any future vertex v' from waves $w' > w$, including u , will have a strong path to at least one vertex in V , resulting in a strong path between u and v . This does not matter if vertex v' is created by a Byzantine process or not, since Byzantine processes cannot equivocate due to the reliable broadcast guarantees. \square

Lemma 6. *Algorithm 3 satisfies the agreement property of the BAB problem.*

PROOF. By Claim 4, each wave has only one vertex that can be committed. By Claim 5 every correct process commits vertices in an increasing wave number. By Lemma 1, if a correct process p_i commits a vertex v , then there is a strong path to v from any vertex u in future waves that might be committed. By combining all the claims, if two correct processes commit the same wave leader vertices, they do so in the same order.

Once a correct process commits a wave vertex leader v , it decides on all of v 's causal history in some deterministic order, which is identical for all other correct processes. By Claim 1, when v is committed, all of v 's causal history is already in the DAG. Thus, since all correct processes commit the same wave leader vertices in the same order, and since those vertices have the same causal histories, all correct processes that decide in some slot, decide the same value. \square

Lemma 7. *Let p_i be a correct process that completes wave w . Then there is a set $V \subseteq DAG_i[\text{round}(w, 1)]$ and a set $U \subseteq DAG_i[\text{round}(w, 4)]$ s.t. $|V| \geq 2f + 1$, $|U| \geq 2f + 1$ and $\forall v \in V, \forall u \in U$: $\text{strong_path}(u, v)$.*

PROOF. First, we show that there is a set V , $|V| \geq 2f + 1$ s.t. when p_i completes $\text{round}(w, 3)$ and broadcasts a new vertex v_4 in $\text{round}(w, 4)$, then v_4 has a strong path to all the vertices in V .

To this end, we use the common-core abstraction, that first appeared in [2], and was adapted (and proven) for the Byzantine case in [20]. The model for this abstraction is identical to our model. Each correct process p_i has some input value v_i , and it returns a set V_i of input values from different processes. The guarantee of the common-core abstraction is that there is a subset V of at least $2f + 1$ values, s.t. for each correct process $V \subseteq V_i$, i.e., there is a common core of at least $2f + 1$ input values that appear in the returned sets of all the correct processes that complete the common-core abstraction.

The algorithm to realize the common-core abstraction consists of three rounds of communication: in the first round, each process sends its input value v_i , and then waits for $2f + 1$ input values from other processes (including itself). Denote this first set at process p_i as F_i .

In the second stage, each process sends its F_i set and waits until it receives $2f + 1$ F_j sets from other processes (including itself). When this stage ends, process p_i creates the union of all the F_j sets it received. Denote this set of sets for process p_i as S_i . In the third and last stage, process p_i sends the set S_i it created and again waits to receive $2f + 1$ S_j sets from other processes (including itself). When this stage ends, process p_i returns the union of all the S_j sets, denoted T_i , as the output of the common-core abstraction.

We show that the first three rounds of a wave w can be mapped exactly to the three stages of the common-core algorithm. Denote r_1, r_2, r_3, r_4 as $\text{round}(w, 1), \text{round}(w, 2), \text{round}(w, 3), \text{round}(w, 4)$, respectively. When a correct process p_i adds the vertex v_1 created in r_1 to $DAG_i[r_1]$, by Claim 2, eventually all other correct processes add v_1 to their DAG, which can be mapped to p_i sending its input value to all other processes in the common-core algorithm. Next, p_i moves to round r_2 once it has at least $2f + 1$ vertices in r_1 , which is mapped to p_i waiting for $2f + 1$ input values from different processes in the common-core algorithm. When p_i enters r_2 it broadcasts a vertex v_2 that references all the vertices it has in r_1 , which is equivalent to p_i sending F_i at the beginning of the second stage of the common-core algorithm. In a similar way, when p_i completes r_2 and enters r_3 , it broadcasts v_3 which references all the vertices it has in r_2 , which is equivalent to sending S_i (by Claim 1, when v_3 is added to $DAG_j[r_3]$ of some correct process p_j , then all the vertices p_i has in $DAG_i[r_1]$ with a strong path from v_3 are in the $DAG_j[r_1]$ as well). To complete the mapping, when p_i completes r_3 and broadcasts v_4 in round r_4 , then v_4 has in its causal history the same values that would have been in T_i in the equivalent common-core algorithm.

Note that since Byzantine processes cannot equivocate, and since every round in the DAG has at least $2f + 1$ vertices, any vertex that p_i adds to $DAG_i[r_4]$ has to reference at least $f + 1$ vertices that v_4 also references, even vertices sent from Byzantine processes. Thus, based on the common-core guarantee, there is a set $V \subseteq DAG_i[r_1]$ s.t. $|V| \geq 2f + 1$ and $\forall v \in V$: $\text{strong_path}(v_4, v)$, and also this set V appears in the DAG of any other correct process p_j that completes round r_3 . Next, when p_i completes wave w , i.e., when it completes round r_4 , it has in $DAG_i[r_4]$ at least $2f + 1$ vertices, and each of those vertices has a path to each of the vertices in V , which concludes the proof. \square

Claim 6. *For every correct process p_i and for every wave w , the expected number of waves, starting from w , until the commit rule is met is equal to or smaller than $3/2 + \epsilon$.*

PROOF. By Lemma 2, in each wave w , the probability that for a correct process p_i the commit rule is met is at least $pr = (2f + 1)/(3f + 1) - \epsilon$. The number of waves until the commit rule is met is geometrically distributed with a success probability of pr . Thus, the expected number of waves is bounded by $3/2 + \epsilon$ waves. \square

Lemma 8. *DAG-Rider guarantees the termination property of the BAB problem.*

PROOF. If a correct process p_i decides a value in slot ℓ it means there is some value in the block of some vertex u that is in the causal history of some wave w leader vertex v that is decided in that slot. By Claim 6, every other correct process p_j that has not committed v yet will eventually, with probability 1, have a wave $w' > w$ in which the commit rule is met. When p_j commits w' , by the proved agreement property, it will also commit v , and thus decide on all of v 's causal history in the same slots, including vertex u in slot ℓ . \square

Claim 7. *Every vertex that is broadcast by a correct process is eventually added to the DAG of all correct processes.*

PROOF. We prove this by showing that for every correct process p_i that broadcasts a vertex v , v is eventually added to DAG_i , and by Claim 2, v is eventually added to the DAG of all other correct processes.

When a correct process p_i broadcasts a vertex v (Line 14) it broadcasts a valid vertex, i.e., a vertex that passes the external validity check, and that references vertices that are already in DAG_i . Because of the validity property of the reliable broadcast, p_i eventually delivers v to itself, and when it does so, it adds v to its own DAG_i . Thus, as explained, by Claim 2, v is eventually added to the DAGs of all other correct processes. \square

Lemma 9. *DAG-Rider guarantees the eventual fairness property of the BAB problem.*

PROOF. When a correct process p_i proposes a value, it is inserted into a queue (Line 33), and eventually will be included in a vertex v created by p_i (Line 16). Vertex v is eventually delivered to all the correct processes and added to their DAGs (Claim 7).

When a correct process broadcasts a new vertex v in round r it also makes sure that it has a path (either a strong path or path that includes weak edges) to all the vertices in rounds $r' < r$, and if not, it adds weak edges to v that guarantee this (Line 27), therefore v will eventually be included in the causal history of all correct processes. By Lemma 7, with probability 1, eventually v will be in the causal history of a committed wave vertex leader, and therefore decided. \square

We proved that DAG-Rider achieves all the properties of the BAB problem as described in §3.

6.2 Communication and Time Complexity

We analyze DAG-Rider in terms of expected communication complexity and expected time complexity.

Communication complexity. We analyze the communication complexity of DAG-Rider when instantiated with Cachin and Tesero's [15] information dispersal protocol. A similar analysis can be made for other broadcast implementations as well. For clarity, in §4, we say that `strongEdges` and `weakEdges` are sets of vertices. However, in order to refer to a vertex it is enough to only store its source and round number.² We assume that any round number during an execution can be expressed in a constant number of bits, that is, the DAG never reaches round number 2^{128} (note that round numbers grow slower than slot numbers).

We count the number of bits sent by correct processes in every round of the DAG and divide it by the total number of ordered values therein. The complexity of [15] is $O(n^2 \log(n) + nM)$, where M is the message (vertex) size. Each

²It is also possible to store vertices hashes.

message includes a set of proposed values and n references, and each reference includes a process id of size $\log(n)$. Thus, if we batch $n \log(n)$ values in every message, the bit complexity is $O(n^2 \log(n) + 2n^2 \log(n)) = O(n^2 \log(n))$ for a broadcast.

Since each process is allowed to broadcast a single message in each round, a correct process will not participate in more than n reliable broadcasts in a round, and thus the total bit complexity of correct processes in a round is bounded by $O(n^3 \log(n))$. On the other hand, at least $2f + 1 = O(n)$ vertices are ordered in every round. Thus, $O(n^2 \log(n))$ values are ordered in every round, which means that the amortized communication complexity of DAG-Rider is $O(n)$.

Time complexity. By Claim 6, the number of waves, in expectation, between two waves that satisfy the commit rule in DAG_i for a correct process p_i is expected constant. Since each wave consists of constant size chains of messages, by the definition of time units, the number of time units, in expectation, between two p_i 's commits is constant. Every time p_i commits a wave, it commits the wave's leader causal history, which contains at least $O(n)$ proposals from different correct processes. Therefore, DAG-Rider's time complexity is $O(1)$ in expectation.

7 RELATED WORK

The first asynchronous Byzantine Agreement protocols [5, 39] showed that the FLP [23] impossibility result can be circumvented with randomization. Their communication and time complexity was exponential and a significant amount of work has been done since then in attempt to achieve optimal complexity under different assumptions. Some works consider the information theoretical settings and present protocols with polylogarithmic complexity that tolerate adversaries with unbounded computational power [4, 26, 38]. Others follow a more practical approach and consider a computationally bounded adversary in order to be able to use cryptographic primitives to improve complexity [1, 13, 14, 35]. The pioneering crypto-based protocols [13, 14] were later realized in HoneyBadgerBFT, the first asynchronous Byzantine SMR system [36]. However, while the state-of-the-art asynchronous Byzantine Agreement protocols VABA [1] and Dumbo [35] rely on cryptographic assumptions for both safety and liveness, DAG-Rider uses a hybrid alternative by providing safety with information theoretical guarantees and relying on cryptographic assumptions only for liveness.

Many other works also presented protocols for the BAB problem in the asynchronous setting. Some works like [29, 40] use cryptographic schemes for safety, and others like [19] do not use signatures. Other works like [22] encapsulate timing assumptions by relying on a failure detector. All these works have higher expected communication complexity.

The idea of building a communication DAG and locally interpreting total order was considered before [18, 21]. To the best of our knowledge, the only algorithms that realize this idea in the Byzantine settings are HashGraph [3] and later Aleph [24]. In contrast to DAG-Rider, HashGraph builds an unstructured DAG in which processes (unreliably) send messages with 2 references to previous vertices and on top of it run an inefficient binary agreement protocol, which leads to expected exponential time complexity. Their communication complexity is not straightforward to analyze since they did not clearly describe the mechanism that ensures that eventually all DAG information is propagated to all processes, and no analysis is provided. Aleph improves HashGraph's complexity by building a round-based DAG and using a more efficient binary agreement protocol [14]. They use an expected constant time binary agreement instance to agree on whether to commit every vertex in a round. However, similarly to VABA and Dumbo based SMR, since they need all instances to terminate before they can totally order all vertices in a round, their time complexity is $O(\log(n))$. They do not amortize complexity and have $O(n^3)$ per decision. In contrast to DAG-Rider, both HashGraph and Aleph (1) do not satisfy eventual fairness; and (2) rely on signatures for safety and thus are not post-quantum safe.

8 CONCLUSION

We presented DAG-Rider: an asynchronous Byzantine Atomic Broadcast protocol with optimal resilience, optimal amortized communication complexity, and optimal time complexity. DAG-Rider does not rely on cryptographic assumptions for safety. Instead, it rules out Byzantine equivocation by relying on the reliable broadcast to guarantee that all correct processes eventually see the same DAG. Finally, we believe that DAG-Rider’s elegant design, perfect load balancing, and modular separation of concerns make it an adequate candidate for future Byzantine SMR systems.

REFERENCES

- [1] Ittai Abraham, Dahlia Malkhi, and Alexander Spiegelman. 2019. Asymptotically Optimal Validated Asynchronous Byzantine Agreement. In *Proceedings of the 2019 ACM Symposium on Principles of Distributed Computing (Toronto ON, Canada) (PODC '19)*. ACM, New York, NY, USA, 337–346. <https://doi.org/10.1145/3293611.3331612>
- [2] Hagit Attiya and Jennifer Welch. 2004. *Distributed computing: fundamentals, simulations, and advanced topics*. Vol. 19. John Wiley & Sons.
- [3] Leemon Baird. 2016. The swirls hashgraph consensus algorithm: Fair, fast, Byzantine fault tolerance. *Swirls Tech Reports SWIRLDS-TR-2016-01, Tech. Rep* (2016).
- [4] Laasya Bangalore, Ashish Choudhury, and Arpita Patra. 2018. Almost-surely terminating asynchronous Byzantine agreement revisited. In *Proceedings of the 2018 ACM Symposium on Principles of Distributed Computing*. 295–304.
- [5] Shai Ben-David, Allan Borodin, Richard Karp, Gabor Tardos, and Avi Wigderson. 1994. On the power of randomization in on-line algorithms. *Algorithmica* 11, 1 (1994), 2–14.
- [6] Michael Ben-Or and Ran El-Yaniv. 2003. Resilient-optimal interactive consistency in constant time. *Distributed Computing* 16, 4 (2003), 249–262.
- [7] Erica Blum, Jonathan Katz, Chen-Da Liu-Zhang, and Julian Loss. 2020. Asynchronous Byzantine Agreement with Subquadratic Communication. In *Theory of Cryptography Conference*. Springer, 353–380.
- [8] Dan Boneh, Ben Lynn, and Hovav Shacham. 2001. Short signatures from the Weil pairing. In *International conference on the theory and application of cryptology and information security*. Springer, 514–532.
- [9] Edward Bortnikov, Maxim Gurevich, Idit Keidar, Gabriel Kliot, and Alexander Shraer. 2009. Brahms: Byzantine resilient random membership sampling. *Computer Networks* 53, 13 (2009), 2340–2359.
- [10] Stephen Boyd, Arpita Ghosh, Balaji Prabhakar, and Devavrat Shah. 2006. Randomized gossip algorithms. *IEEE/ACM Transactions on Networking (TON)* 14, SI (2006), 2508–2530.
- [11] Gabriel Bracha. 1987. Asynchronous Byzantine agreement protocols. *Information and Computation* 75, 2 (1987), 130–143.
- [12] Christian Cachin, Rachid Guerraoui, and Luís Rodrigues. 2011. *Introduction to reliable and secure distributed programming*. Springer Science & Business Media.
- [13] Christian Cachin, Klaus Kursawe, Frank Petzold, and Victor Shoup. 2001. Secure and efficient asynchronous broadcast protocols. In *Annual International Cryptology Conference*. Springer, 524–541.
- [14] Christian Cachin, Klaus Kursawe, and Victor Shoup. 2005. Random oracles in Constantinople: Practical asynchronous Byzantine agreement using cryptography. *Journal of Cryptology* 18, 3 (2005), 219–246.
- [15] Christian Cachin and Stefano Tessaro. 2005. Asynchronous verifiable information dispersal. In *24th IEEE Symposium on Reliable Distributed Systems (SRDS'05)*. IEEE, 191–201.
- [16] Ran Canetti and Tal Rabin. 1993. Fast asynchronous Byzantine agreement with optimal resilience. In *Proceedings of the twenty-fifth annual ACM symposium on Theory of computing*. 42–51.
- [17] Miguel Castro, Barbara Liskov, et al. 1999. Practical Byzantine fault tolerance. In *OSDI*, Vol. 99. 173–186.
- [18] Gregory V Chockler, Nabil Huleihel, and Danny Dolev. 1998. An adaptive totally ordered multicast protocol that tolerates partitions. In *Proceedings of the seventeenth annual ACM symposium on Principles of distributed computing*. 237–246.
- [19] Miguel Correia, Nuno Ferreira Neves, and Paulo Verissimo. 2006. From consensus to atomic broadcast: Time-free Byzantine-resistant protocols without signatures. *Comput. J.* 49, 1 (2006), 82–96.
- [20] Danny Dolev and Eli Gafni. 2016. Some garbage in-some garbage out: Asynchronous t-Byzantine as asynchronous benign t-resilient system with fixed t-trojan-horse inputs. *arXiv preprint arXiv:1607.01210* (2016).
- [21] Danny Dolev, Shlomo Kramer, and Dalia Malki. 1993. Early delivery totally ordered multicast in asynchronous environments. In *FTCS-23 The Twenty-Third International Symposium on Fault-Tolerant Computing*. IEEE, 544–553.
- [22] Assia Doudou, Benoit Garbinato, and Rachid Guerraoui. 2000. Abstractions for devising Byzantine-resilient state machine replication. In *Proceedings 19th IEEE Symposium on Reliable Distributed Systems SRDS-2000*. IEEE, 144–153.
- [23] Michael J Fischer, Nancy A Lynch, and Michael S Paterson. 1985. Impossibility of distributed consensus with one faulty process. *Journal of the ACM (JACM)* 32, 2 (1985), 374–382.
- [24] Adam Gkagol, Damian Lesniak, Damian Straszak, and Michal Swiketec. 2019. Aleph: Efficient atomic broadcast in asynchronous networks with Byzantine nodes. In *Proceedings of the 1st ACM Conference on Advances in Financial Technologies*. 214–228.

- [25] Rachid Guerraoui, Petr Kuznetsov, Matteo Monti, Matej Pavlovic, and Dragos-Adrian Seredinschi. 2019. Scalable Byzantine Reliable Broadcast. In *33rd International Symposium on Distributed Computing (DISC 2019)*. Schloss Dagstuhl-Leibniz-Zentrum fuer Informatik.
- [26] Bruce M Kapron, David Kempe, Valerie King, Jared Saia, and Vishal Sanwalani. 2010. Fast asynchronous Byzantine agreement and leader election with full information. *ACM Transactions on Algorithms (TALG)* 6, 4 (2010), 1–28.
- [27] Richard Karp, Christian Schindelhauer, Scott Shenker, and Berthold Vocking. 2000. Randomized rumor spreading. In *Proceedings 41st Annual Symposium on Foundations of Computer Science*. IEEE, 565–574.
- [28] Mahimna Kelkar, Fan Zhang, Steven Goldfeder, and Ari Juels. 2020. Order-fairness for Byzantine consensus. In *Annual International Cryptology Conference*. Springer, 451–480.
- [29] Kim Potter Kihlstrom, Louise E Moser, and P Michael Melliar-Smith. 2001. The SecureRing group communication system. *ACM Transactions on Information and System Security (TISSEC)* 4, 4 (2001), 371–406.
- [30] Eleftherios Kokoris Kogias, Dahlia Malkhi, and Alexander Spiegelman. 2020. Asynchronous Distributed Key Generation for Computationally-Secure Randomness, Consensus, and Threshold Signatures.. In *Proceedings of the 2020 ACM SIGSAC Conference on Computer and Communications Security*. 1751–1767.
- [31] Ramakrishna Kotla, Lorenzo Alvisi, Mike Dahlin, Allen Clement, and Edmund Wong. 2007. Zyzyva: speculative Byzantine fault tolerance. In *ACM SIGOPS Operating Systems Review*, Vol. 41. ACM, 45–58.
- [32] Kfir Lev-Ari, Alexander Spiegelman, Idit Keidar, and Dahlia Malkhi. 2020. FairLedger: A Fair Blockchain Protocol for Financial Institutions. In *23rd International Conference on Principles of Distributed Systems (OPODIS 2019)*. Schloss Dagstuhl-Leibniz-Zentrum für Informatik.
- [33] Benoît Libert, Marc Joye, and Moti Yung. 2016. Born and raised distributively: Fully distributed non-interactive adaptively-secure threshold signatures with short shares. *Theoretical Computer Science* 645 (2016), 1–24.
- [34] Julian Loss and Tal Moran. 2018. Combining Asynchronous and Synchronous Byzantine Agreement: The Best of Both Worlds. *IACR Cryptol. ePrint Arch.* 2018 (2018), 235.
- [35] Yuan Lu, Zhenliang Lu, Qiang Tang, and Guiling Wang. 2020. Dumbo-mvba: Optimal multi-valued validated asynchronous Byzantine agreement, revisited. In *Proceedings of the 39th Symposium on Principles of Distributed Computing*. 129–138.
- [36] Andrew Miller, Yu Xia, Kyle Croman, Elaine Shi, and Dawn Song. 2016. The honey badger of BFT protocols. In *Proceedings of the 2016 ACM SIGSAC Conference on Computer and Communications Security*. 31–42.
- [37] Satoshi Nakamoto. 2008. *Bitcoin: A peer-to-peer electronic cash system*. Technical Report.
- [38] Arpita Patra, Ashish Choudhury, and C Pandu Rangan. 2014. Asynchronous Byzantine agreement with optimal resilience. *Distributed computing* 27, 2 (2014), 111–146.
- [39] Michael O Rabin. 1983. Randomized Byzantine generals. In *24th Annual Symposium on Foundations of Computer Science (sfcs 1983)*. IEEE, 403–409.
- [40] Michael K Reiter. 1994. Secure agreement protocols: Reliable and atomic group multicast in Rampart. In *Proceedings of the 2nd ACM Conference on Computer and Communications Security*. 68–80.
- [41] Adi Shamir. 1979. How to share a secret. *Commun. ACM* 22, 11 (1979), 612–613.
- [42] Victor Shoup. 2000. Practical threshold signatures. In *International Conference on the Theory and Applications of Cryptographic Techniques*. Springer, 207–220.
- [43] Maofan Yin, Dahlia Malkhi, MK Reiter and, Guy Golan Gueta, and Ittai Abraham. 2019. HotStuff: BFT consensus with linearity and responsiveness. In *38th ACM symposium on Principles of Distributed Computing (PODC'19)*.