

New Distributed Source Encryption Framework

Yasutada Oohama and Bagus Santoso
University of Electro-Communications, Tokyo, Japan
Email: {oohama,santoso.bagus}@uec.ac.jp

Abstract—We pose and investigate the distributed secure source coding based on the common key cryptosystem. This cryptosystem includes the secrecy amplification problem for distributed encrypted sources with correlated keys using post-encryption-compression, which was posed investigated by Santoso and Oohama. In this paper we propose a new security criterion which is more natural compared with the commonly used security criterion which is based on the upper-bound of mutual information between the plaintext and the ciphertext. Under this criterion, we establish the necessary and sufficient condition for the secure transmission of correlated sources.

I. INTRODUCTION

In this paper we pose and investigate the distributed secure source coding based on the common key cryptosystem. This cryptosystem includes the secrecy amplification problem for distributed encrypted sources with correlated keys using post-encryption-compression (PEC), which was posed investigated by Santoso and Oohama in [1], [2].

In this paper we propose a new security criterion which is more natural compared with the commonly used security criterion based on the upper-bound of mutual information between the plaintext and the ciphertext. For the proposed new metric we prove its *validity*. Concretely we establish the following two results:

- We prove that if the mutual information is zero, then the proposed criterion is strictly zero.
- The proposed criterion depends only on the property of the cryptosystem, implying that this criterion is more natural than the widely-used security metric based mutual information.

For the proposed security criterion, the part a) is quite essential. Without this condition, the criterion is meaningless.

Under the proposed security criterion we prove the strong converse theorem. We further derive a sufficient condition to achieve security. This sufficient condition matches the necessary condition. In our previous works of Santoso and Oohama [1], [2], we have derived a sufficient condition under the security criterion measured by the mutual information. To derive the sufficient condition we use the coding scheme proposed by Santoso and Oohama. We obtain the same sufficient condition as that of Santoso and Oohama [1], [2] under more natural condition than the mutual information.

Our study in this paper has a closely related to several previous works on the PEC, e.g., Johnson et al. [3], Klinc et al. [4]. Our study also has a close connection with several previous works on the Shannon cipher system, e.g. [5], [6] [7].

II. SECURE SOURCE CODING PROBLEM

A. Preliminaries

In this subsection, we show the basic notations and related consensus used in this paper.

Random Sources of Information and Keys: Let (X_1, X_2) be a pair of random variables from a finite set $\mathcal{X}_1 \times \mathcal{X}_2$. Let $\{(X_{1,t}, X_{2,t})\}_{t=1}^{\infty}$ be a stationary *discrete memoryless source* (DMS) such that for each $t = 1, 2, \dots$, the pair $(X_{1,t}, X_{2,t})$ takes values in finite set $\mathcal{X}_1 \times \mathcal{X}_2$ and obeys the same distribution as that of (X_1, X_2) denoted by $p_{X_1 X_2} = \{p_{X_1 X_2}(x_1, x_2)\}_{(x_1, x_2) \in \mathcal{X}_1 \times \mathcal{X}_2}$. The stationary DMS $\{(X_{1,t}, X_{2,t})\}_{t=1}^{\infty}$ is specified with $p_{X_1 X_2}$. Also, let (K_1, K_2) be a pair of random variables taken from the same finite set $\mathcal{X}_1 \times \mathcal{X}_2$ representing the pair of keys used for encryption at two separate terminals, of which the detailed description will be presented later. Similarly, let $\{(K_{1,t}, K_{2,t})\}_{t=1}^{\infty}$ be a stationary discrete memoryless source such that for each $t = 1, 2, \dots$, the pair $(K_{1,t}, K_{2,t})$ takes values in finite set $\mathcal{X}_1 \times \mathcal{X}_2$ and obeys the same distribution as that of (K_1, K_2) denoted by $p_{K_1 K_2} = \{p_{K_1 K_2}(k_1, k_2)\}_{(k_1, k_2) \in \mathcal{X}_1 \times \mathcal{X}_2}$. The stationary DMS $\{(K_{1,t}, K_{2,t})\}_{t=1}^{\infty}$ is specified with $p_{K_1 K_2}$.

Random Variables and Sequences: We write the sequence of random variables with length n from the information source as follows: $\mathbf{X}_1 := X_{1,1} X_{1,2} \cdots X_{1,n}$, $\mathbf{X}_2 := X_{2,1} X_{2,2} \cdots X_{2,n}$. Similarly, the strings with length n of \mathcal{X}_1^n and \mathcal{X}_2^n are written as $\mathbf{x}_1 := x_{1,1} x_{1,2} \cdots x_{1,n} \in \mathcal{X}_1^n$ and $\mathbf{x}_2 := x_{2,1} x_{2,2} \cdots x_{2,n} \in \mathcal{X}_2^n$ respectively. For $(\mathbf{x}_1, \mathbf{x}_2) \in \mathcal{X}_1^n \times \mathcal{X}_2^n$, $p_{\mathbf{X}_1 \mathbf{X}_2}(\mathbf{x}_1, \mathbf{x}_2)$ stands for the probability of the occurrence of $(\mathbf{x}_1, \mathbf{x}_2)$. When the information source is memoryless specified with $p_{X_1 X_2}$, we have the following equation holds: $p_{\mathbf{X}_1 \mathbf{X}_2}(\mathbf{x}_1, \mathbf{x}_2) = \prod_{t=1}^n p_{X_1 X_2}(x_{1,t}, x_{2,t})$. In this case we write $p_{\mathbf{X}_1 \mathbf{X}_2}(\mathbf{x}_1, \mathbf{x}_2)$ as $p_{\mathbf{X}_1 \mathbf{X}_2}^n(\mathbf{x}_1, \mathbf{x}_2)$. Similar notations are used for other random variables and sequences.

Consensus and Notations: Without loss of generality, throughout this paper, we assume that \mathcal{X}_1 and \mathcal{X}_2 are finite fields. The notation \oplus is used to denote the field addition operation, while the notation \ominus is used to denote the field subtraction operation, i.e., $a \ominus b = a \oplus (-b)$ for any elements a, b of a same finite field. For the sake of simplicity, we use the same notation for field addition and subtraction for both \mathcal{X}_1 and \mathcal{X}_2 . Throughout this paper all logarithms are taken to the base 2.

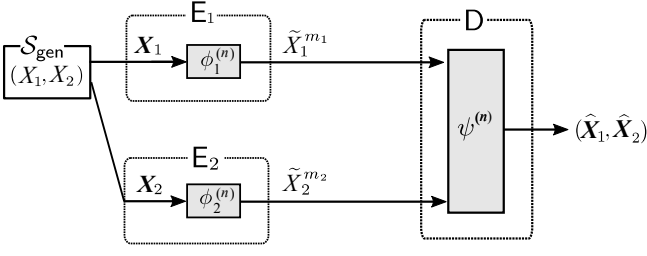

Fig. 1. Distributed source coding without encryption.

B. Basic System Description

First, let the information sources and keys be generated independently by different parties \mathcal{S}_{gen} and \mathcal{K}_{gen} respectively. In our setting, we assume the followings.

- The random keys \mathbf{K}_1 and \mathbf{K}_2 are generated by \mathcal{K}_{gen} .
- The key \mathbf{K}_1 is correlated to \mathbf{K}_2 .
- The sources \mathbf{X}_1 and \mathbf{X}_2 are generated by \mathcal{S}_{gen} and are correlated to each other.
- The sources are independent to the keys.

Source coding without encryption: The two correlated random sources \mathbf{X}_1 and \mathbf{X}_2 from \mathcal{S}_{gen} be sent to two separated nodes E_1 and E_2 respectively. Further settings of the system are described as follows. Those are also shown in Fig. 1.

- 1) *Encoding Process:* For each $i = 1, 2$, at the node E_i , the encoder function $\phi_i^{(n)} : \mathcal{X}_i^n \rightarrow \mathcal{X}_i^{m_i}$ observes \mathbf{X}_i to generate $\tilde{X}_i^{m_i} = \phi_i^{(n)}(\mathbf{X}_i)$. Without loss of generality we may assume that $\phi_i^{(n)}$ is *surjective*.
- 2) *Transmission:* Next, the encoded sources $\tilde{X}_i^{m_i}$, $i = 1, 2$ are sent to the information processing center D through two *noiseless* channels.
- 3) *Decoding Process:* In D, the decoder function observes $\tilde{X}_i^{m_i}$, $i = 1, 2$ to output $(\hat{\mathbf{X}}_1, \hat{\mathbf{X}}_2)$, using the one-to-one mapping $\psi^{(n)}$ defined by $\psi^{(n)} : \mathcal{X}_1^{m_1} \times \mathcal{X}_2^{m_2} \rightarrow \mathcal{X}_1^n \times \mathcal{X}_2^n$. Here we set

$$\begin{aligned} (\hat{\mathbf{X}}_1, \hat{\mathbf{X}}_2) &:= \psi^{(n)}(\tilde{X}_1^{m_1}, \tilde{X}_2^{m_2}) \\ &= \psi^{(n)}\left(\phi_1^{(n)}(\mathbf{X}_1), \phi_2^{(n)}(\mathbf{X}_2)\right). \end{aligned}$$

More concretely, the decoder outputs the unique pair $(\hat{\mathbf{X}}_1, \hat{\mathbf{X}}_2)$ from $(\phi_1^{(n)})^{-1}(\tilde{X}_1^{m_1}) \times (\phi_2^{(n)})^{-1}(\tilde{X}_2^{m_2})$ in a proper manner.

For the above $(\phi_1^{(n)}, \phi_2^{(n)}, \psi^{(n)})$, we define the set $\mathcal{D}^{(n)}$ of correct decoding by

$$\begin{aligned} \mathcal{D}^{(n)} &:= \{(\mathbf{x}_1, \mathbf{x}_2) \in \mathcal{X}_1^n \times \mathcal{X}_2^n : \\ &\psi^{(n)}(\phi_1^{(n)}(\mathbf{x}_1), \phi_2^{(n)}(\mathbf{x}_2)) = (\mathbf{x}_1, \mathbf{x}_2)\}. \end{aligned}$$

On $|\mathcal{D}^{(n)}|$, we have the following property.

Property 1: We have the following.

$$|\mathcal{D}^{(n)}| = |\mathcal{X}_1^{m_1}| |\mathcal{X}_2^{m_2}|. \quad (1)$$

Proof of Property 1 is given in Appendix A.

Distributed source coding with encryption:

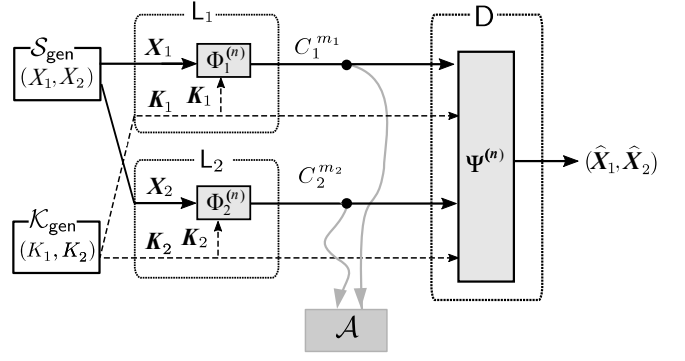

Fig. 2. Distributed source coding with encryption.

The two correlated random sources \mathbf{X}_1 and \mathbf{X}_2 from \mathcal{S}_{gen} are sent to two separated nodes L_1 and L_2 , respectively. The two random keys \mathbf{K}_1 and \mathbf{K}_2 from \mathcal{K}_{gen} , are also sent to L_1 and L_2 , respectively. Further settings of our system are described as follows. Those are also shown in Fig. 2.

- 1) *Source Processing:* For each $i = 1, 2$, at the node i , \mathbf{X}_i is encrypted with the key \mathbf{K}_i using the encryption function $\Phi_i^{(n)} : \mathcal{X}_i^n \times \mathcal{X}_i^n \rightarrow \mathcal{X}_i^{m_i}$. For each $i = 1, 2$, the ciphertext $C_i^{m_i}$ of \mathbf{X}_i is given by $C_i^{m_i} = \Phi_i^{(n)}(\mathbf{K}_i, \mathbf{X}_i)$. On the encryption function $\Phi_i^{(n)}$, $i = 1, 2$, we use the following notation:

$$\Phi_i^{(n)}(\mathbf{K}_i, \mathbf{X}_i) = \Phi_{i, \mathbf{K}_i}^{(n)}(\mathbf{X}_i) = \Phi_{i, \mathbf{X}_i}^{(n)}(\mathbf{K}_i).$$

- 2) *Transmission:* Next, the ciphertext $C_i^{m_i}$, $i = 1, 2$ are sent to the information processing center D through two *public* communication channels. Meanwhile, the key \mathbf{K}_i , $i = 1, 2$, are sent to D through two *private* communication channels.

- 3) *Sink Node Processing:* In D, we decrypt the ciphertext $(\hat{\mathbf{X}}_1, \hat{\mathbf{X}}_2)$ from $C_i^{m_i}$, $i = 1, 2$, using the key \mathbf{K}_i , $i = 1, 2$, through the corresponding decryption procedure $\Psi^{(n)}$ defined by $\Psi^{(n)} : \mathcal{X}_1^n \times \mathcal{X}_2^n \times \mathcal{X}_1^{m_1} \times \mathcal{X}_2^{m_2} \rightarrow \mathcal{X}_1^n \times \mathcal{X}_2^n$. Here we set

$$(\hat{\mathbf{X}}_1, \hat{\mathbf{X}}_2) := \Psi^{(n)}(\mathbf{K}_1, \mathbf{K}_2, C_1^{m_1}, C_2^{m_2}).$$

More concretely, the decoder outputs the unique pair $(\hat{\mathbf{X}}_1, \hat{\mathbf{X}}_2)$ from $(\Phi_{1, \mathbf{K}_1}^{(n)})^{-1}(C_1^{m_1}) \times (\Phi_{2, \mathbf{K}_2}^{(n)})^{-1}(C_2^{m_2})$ in a proper manner. On the decryption function $\Psi^{(n)}$, we use the following notation:

$$\begin{aligned} \Psi^{(n)}(\mathbf{K}_1, \mathbf{K}_2, C_1^{m_1}, C_2^{m_2}) &= \Psi_{\mathbf{K}_1, \mathbf{K}_2}^{(n)}(C_1^{m_1}, C_2^{m_2}) \\ &= \Psi_{C_1^{m_1}, C_2^{m_2}}^{(n)}(\mathbf{K}_1, \mathbf{K}_2). \end{aligned}$$

Fix any $(\mathbf{K}_1, \mathbf{K}_2) = (\mathbf{k}_1, \mathbf{k}_2) \in \mathcal{X}_1^n \times \mathcal{X}_2^n$. For this $(\mathbf{K}_1, \mathbf{K}_2)$ and for $(\Phi_1^{(n)}, \Phi_2^{(n)}, \Psi^{(n)})$, we define the set $\mathcal{D}_{\mathbf{k}_1, \mathbf{k}_2}^{(n)}$ of correct decoding by

$$\begin{aligned} \mathcal{D}_{\mathbf{k}_1, \mathbf{k}_2}^{(n)} &:= \{(\mathbf{x}_1, \mathbf{x}_2) \in \mathcal{X}_1^n \times \mathcal{X}_2^n : \\ &\Psi^{(n)}(\Phi_1^{(n)}(\mathbf{k}_1, \mathbf{x}_1), \Phi_2^{(n)}(\mathbf{k}_2, \mathbf{x}_2)) = (\mathbf{x}_1, \mathbf{x}_2)\}. \end{aligned}$$

We require that the cryptosystem $(\Phi_1^{(n)}, \Phi_2^{(n)}, \Psi^{(n)})$ must satisfy the following condition.

Condition: For each distributed source encryption system $(\Phi_1^{(n)}, \Phi_2^{(n)}, \Psi^{(n)})$, there exists a distributed source coding system $(\phi_1^{(n)}, \phi_2^{(n)}, \psi^{(n)})$ such that for any $(\mathbf{k}_1, \mathbf{k}_2) \in \mathcal{X}_1^n \times \mathcal{X}_2^n$ and for any $(\mathbf{x}_1, \mathbf{x}_2) \in \mathcal{X}_1^n \times \mathcal{X}_2^n$,

$$\begin{aligned} & \Psi_{\mathbf{k}_1, \mathbf{k}_2}^{(n)}(\Phi_{1, \mathbf{k}_1}^{(n)}(\mathbf{x}_1), \Phi_{2, \mathbf{k}_2}^{(n)}(\mathbf{x}_2)) \\ &= \psi^{(n)}(\phi_1^{(n)}(\mathbf{x}_1), \phi_2^{(n)}(\mathbf{x}_2)). \end{aligned}$$

The above condition implies that

$$\mathcal{D}^{(n)} = \mathcal{D}_{\mathbf{k}_1, \mathbf{k}_2}^{(n)}, \forall (\mathbf{k}_1, \mathbf{k}_2) \in \mathcal{X}_1^n \times \mathcal{X}_2^n.$$

We have the following properties on $\mathcal{D}^{(n)}$.

Property 2:

a) If $(\mathbf{x}_1, \mathbf{x}_2), (\mathbf{x}'_1, \mathbf{x}'_2) \in \mathcal{D}^{(n)}$ and $(\mathbf{x}_1, \mathbf{x}_2) \neq (\mathbf{x}'_1, \mathbf{x}'_2)$, then

$$(\Phi_{1, \mathbf{k}_1}^{(n)}(\mathbf{x}_1), \Phi_{2, \mathbf{k}_2}^{(n)}(\mathbf{x}_2)) \neq (\Phi_{1, \mathbf{k}_1}^{(n)}(\mathbf{x}'_1), \Phi_{2, \mathbf{k}_2}^{(n)}(\mathbf{x}'_2)).$$

b) $\forall (\mathbf{k}_1, \mathbf{k}_2)$ and $\forall (c_1^{m_1}, c_2^{m_2}), \exists (\mathbf{x}_1, \mathbf{x}_2) \in \mathcal{D}^{(n)}$ such that

$$(\Phi_{1, \mathbf{k}_1}^{(n)}(\mathbf{x}_1), \Phi_{2, \mathbf{k}_2}^{(n)}(\mathbf{x}_2)) = (c_1^{m_1}, c_2^{m_2}).$$

Proof of Property 2 is given in Appendix B. On the above distributed source encryption scheme, we have an important lemma. Before describing this lemma we give an observation on $p_{C_1^{m_1} C_2^{m_2} | \mathbf{X}_1 \mathbf{X}_2}$. For $(\mathbf{x}_1, \mathbf{x}_2) \in \mathcal{X}_1^n \times \mathcal{X}_2^n$, we set

$$\begin{aligned} & \mathcal{A}_{\mathbf{x}_1, \mathbf{x}_2}(c_1^{m_1}, c_2^{m_2}) \\ &:= \left\{ (\mathbf{k}_1, \mathbf{k}_2) : \Phi_{i, \mathbf{k}_i}^{(n)}(\mathbf{k}_i) = c_i^{m_i}, i = 1, 2 \right\}. \end{aligned}$$

We have that for each $(c_1^{m_1}, c_2^{m_2}, \mathbf{x}_1, \mathbf{x}_2) \in \mathcal{X}_1^{m_1} \times \mathcal{X}_2^{m_2} \times \mathcal{X}_1^n \times \mathcal{X}_2^n$,

$$\begin{aligned} & p_{C_1^{m_1} C_2^{m_2} | \mathbf{X}_1 \mathbf{X}_2}(c_1^{m_1}, c_2^{m_2} | \mathbf{x}_1, \mathbf{x}_2) \\ &= \Pr \left\{ (\mathbf{K}_1, \mathbf{K}_2) \in \mathcal{A}_{\mathbf{x}_1, \mathbf{x}_2}(c_1^{m_1}, c_2^{m_2}) \mid \mathbf{X}_1 = \mathbf{x}_1, \mathbf{X}_2 = \mathbf{x}_2 \right\} \\ &\stackrel{(a)}{=} \Pr \left\{ (\mathbf{K}_1, \mathbf{K}_2) \in \mathcal{A}_{\mathbf{x}_1, \mathbf{x}_2}(c_1^{m_1}, c_2^{m_2}) \right\}. \end{aligned} \quad (2)$$

Step (a) follows from $(\mathbf{K}_1, \mathbf{K}_2) \perp (\mathbf{X}_1, \mathbf{X}_2)$. We can see from (14) that for each $(\mathbf{x}_1, \mathbf{x}_2) \in \mathcal{X}_1^n \times \mathcal{X}_2^n$, the component $p_{C_1^{m_1} C_2^{m_2} | \mathbf{X}_1 \mathbf{X}_2}(c_1^{m_1}, c_2^{m_2} | \mathbf{x}_1, \mathbf{x}_2)$ of the stochastic matrix

$$\begin{aligned} & p_{C_1^{m_1} C_2^{m_2} | \mathbf{X}_1 \mathbf{X}_2}(\cdot, \cdot | \mathbf{x}_1, \mathbf{x}_2) \\ &= \left\{ p_{C_1^{m_1} C_2^{m_2} | \mathbf{X}_1 \mathbf{X}_2}(c_1^{m_1}, c_2^{m_2} | \mathbf{x}_1, \mathbf{x}_2) \right\}_{(c_1^{m_1}, c_2^{m_2}) \in \mathcal{X}_1^{m_1} \times \mathcal{X}_2^{m_2}} \end{aligned}$$

can be written as

$$\begin{aligned} & p_{C_1^{m_1} C_2^{m_2} | \mathbf{X}_1 \mathbf{X}_2}(c_1^{m_1}, c_2^{m_2} | \mathbf{x}_1, \mathbf{x}_2) \\ &= \Gamma_{\mathbf{K}_1 \mathbf{K}_2, (\mathbf{x}_1, \mathbf{x}_2)}(c_1^{m_1}, c_2^{m_2}). \end{aligned}$$

Furthermore, the quantity

$$\begin{aligned} & \Gamma_{\mathbf{K}_1 \mathbf{K}_2, (\mathbf{x}_1, \mathbf{x}_2)} \\ &:= \left\{ \Gamma_{\mathbf{K}_1 \mathbf{K}_2, (\mathbf{x}_1, \mathbf{x}_2)}(c_1^{m_1}, c_2^{m_2}) \right\}_{(c_1^{m_1}, c_2^{m_2}) \in \mathcal{X}_1^{m_1} \times \mathcal{X}_2^{m_2}} \end{aligned}$$

can be regarded as a joint distribution indexed by $(\mathbf{x}_1, \mathbf{x}_2) \in \mathcal{X}_1^n \times \mathcal{X}_2^n$. Here the random pair $(\mathbf{K}_1, \mathbf{K}_2)$ appearing in

$\Gamma_{\mathbf{K}_1 \mathbf{K}_2, (\mathbf{x}_1, \mathbf{x}_2)}$ stands for that the randomness of the joint probability distribution is from that of $(\mathbf{K}_1, \mathbf{K}_2)$. From Property 2, we have the following result, which is a key result of this paper.

Lemma 1: $\forall (c_1^{m_1}, c_2^{m_2}) \in \mathcal{X}_1^{m_1} \times \mathcal{X}_2^{m_2}$, we have

$$\sum_{(\mathbf{x}_1, \mathbf{x}_2) \in \mathcal{D}^{(n)}} \Gamma_{\mathbf{K}_1 \mathbf{K}_2, (\mathbf{x}_1, \mathbf{x}_2)}(c_1^{m_1}, c_2^{m_2}) = 1.$$

Proof of Lemma 1 is given in Appendix C. This lemma can be regarded as an extension of the Birkhoff-von Neumann theorem [8].

III. MAIN RESULTS

A. Proposed Security Criterion

In this section, we introduce our proposed security criterion. In the following arguments all logarithms are taken to the base natural. The adversary \mathcal{A} tries to estimate $(\mathbf{X}_1, \mathbf{X}_2) \in \mathcal{X}_1 \times \mathcal{X}_1^n$ from $(C_1^{m_1}, C_2^{m_2})$.

The mutual information (MI) between $(\mathbf{X}_1, \mathbf{X}_2)$ and $(C_1^{m_1}, C_2^{m_2})$ denoted by

$$\Delta_{\text{MI}}^{(n)} := I(C_1^{m_1} C_2^{m_2}; \mathbf{X}_1 \mathbf{X}_2)$$

indicates a leakage of information on $(\mathbf{X}_1, \mathbf{X}_2)$ from $(C_1^{m_1}, C_2^{m_2})$. In this sense it seems to be quite natural to adopt the mutual information $\Delta_{\text{MI}}^{(n)}$ as a security criterion. On the other hand, directly using $\Delta_{\text{MI}}^{(n)}$ as a security criterion of the cryptosystem has some problem that this value depends on the statistical property of $(\mathbf{X}_1, \mathbf{X}_2)$. In this paper we propose a new security criterion, which is based on $\Delta_{\text{MI}}^{(n)}$ but overcomes the above problem.

Definition 1: Let $(\overline{\mathbf{X}}_1, \overline{\mathbf{X}}_2)$ be an arbitrary random variable taking values in $\mathcal{X}_1^n \times \mathcal{X}_2^n$. Set $\overline{C}_i^{m_i} = \Phi_i^{(n)}(\mathbf{K}_i, \overline{\mathbf{X}}_i), i = 1, 2$. Define

$$\begin{aligned} \text{Supp}(p_{\overline{\mathbf{X}}_1 \overline{\mathbf{X}}_2}) &:= \{(\mathbf{x}_1, \mathbf{x}_2) \in \mathcal{X}_1^n \times \mathcal{X}_2^n : \\ & p_{\overline{\mathbf{X}}_1 \overline{\mathbf{X}}_2}(\mathbf{x}_1, \mathbf{x}_2) > 0\}, \\ \mathcal{P}(\mathcal{D}^{(n)}) &:= \{p_{\overline{\mathbf{X}}_1 \overline{\mathbf{X}}_2} \in \mathcal{P}(\mathcal{X}_1^n \times \mathcal{X}_2^n) : \\ & \text{Supp}(p_{\overline{\mathbf{X}}_1 \overline{\mathbf{X}}_2}) = \mathcal{D}^{(n)}\}. \end{aligned}$$

The maximum mutual information criterion denoted by $\Delta_{\text{max-MI}}^{(n)}$ is as follows.

$$\begin{aligned} \Delta_{\text{max-MI}}^{(n)} &= \Delta_{\text{max-MI}}^{(n)}(\Phi_1^{(n)}, \Phi_2^{(n)}, \Psi^{(n)} | p_{\mathbf{K}_1 \mathbf{K}_2}^n) \\ &:= \max_{p_{\overline{\mathbf{X}}_1 \overline{\mathbf{X}}_2} \in \mathcal{P}(\mathcal{D}^{(n)})} I(\overline{C}_1^{m_1} \overline{C}_2^{m_2}; \overline{\mathbf{X}}_1 \overline{\mathbf{X}}_2). \end{aligned}$$

We further define the following quantity.

$$\begin{aligned} \overline{\Delta}_{\text{max-MI}}^{(n)} &= \overline{\Delta}_{\text{max-MI}}^{(n)}(\Phi_1^{(n)}, \Phi_2^{(n)} | p_{\mathbf{K}_1 \mathbf{K}_2}^n) \\ &:= \max_{p_{\overline{\mathbf{X}}_1 \overline{\mathbf{X}}_2} \in \mathcal{P}(\mathcal{X}_1^n \times \mathcal{X}_2^n)} I(\overline{C}_1^{m_1} \overline{C}_2^{m_2}; \overline{\mathbf{X}}_1 \overline{\mathbf{X}}_2). \end{aligned}$$

By definition it is obvious that $\Delta_{\text{MI}}^{(n)} \leq \overline{\Delta}_{\text{max-MI}}^{(n)}$ and $\Delta_{\text{max-MI}}^{(n)} \leq \overline{\Delta}_{\text{max-MI}}^{(n)}$. We have the following proposition on $\Delta_{\text{MI}}^{(n)}, \Delta_{\text{max-MI}}^{(n)}$, and $\overline{\Delta}_{\text{max-MI}}^{(n)}$:

Proposition 1:

a) We have the following:

$$\max\{\Delta_{\text{MI}}^{(n)}, \Delta_{\text{max-MI}}^{(n)}\} \leq \overline{\Delta}_{\text{max-MI}}^{(n)}$$

b) We assume that

$$\mathcal{D}^{(n)} \subseteq \text{Supp}(p_{X_1 X_2}^n) = \text{Supp}^n(p_{X_1 X_2}).$$

Under this assumption, if $\Delta_{\text{MI}}^{(n)} = I(C_1^{m_1} C_2^{m_2}; \mathbf{X}_1 \mathbf{X}_2) = 0$, then, we have $\Delta_{\text{max-MI}}^{(n)} = 0$. This implies that $\Delta_{\text{max-MI}}^{(n)}$ is valid as a measure of information leakage.

c) We have the following.

$$\begin{aligned} \Delta_{\text{max-MI}}^{(n)} &\geq \max\{m_1 \log |\mathcal{X}_1| - nH(K_1), \\ &\quad m_2 \log |\mathcal{X}_2| - nH(K_2), \\ &\quad m_1 \log |\mathcal{X}_1| + m_2 \log |\mathcal{X}_2| - nH(K_1 K_2)\}. \end{aligned}$$

Proof of Proposition 1 is given in Appendix D.

Remark 1: The part b) in the above proposition is quite essential. If we have a security criterion $\widehat{\Delta}^{(n)}$ not satisfying this condition, it may happen that $\Delta_{\text{MI}}^{(n)} = I(C_1^{m_1} C_2^{m_2}; \mathbf{X}_1 \mathbf{X}_2) = 0$, but $\widehat{\Delta}^{(n)} > 0$. Such $\widehat{\Delta}^{(n)}$ is invalid for the security criterion.

Remark 2: The property stated in the part c) is a key important property of $\Delta_{\text{max-MI}}^{(n)}$, which plays an important role in establishing the strong converse theorem. Lemma 1 is a key result for the proof of the part b).

Defining Reliability and Security: The decoding process is successful if $(\widehat{\mathbf{X}}_1, \widehat{\mathbf{X}}_2) = (\mathbf{X}_1, \mathbf{X}_2)$ holds. Hence the decoding error probability is given by

$$\begin{aligned} &\Pr[\Psi^{(n)}(\mathbf{K}_1, \mathbf{K}_2, \phi_1^{(n)}(\mathbf{K}_1, \mathbf{X}_1), \phi_2^{(n)}(\mathbf{K}_2, \mathbf{X}_2)) \\ &\quad \neq (\mathbf{X}_1, \mathbf{X}_2)] \\ &= \Pr[\Psi_{\mathbf{K}_1, \mathbf{K}_2}^{(n)}(\Phi_{1, \mathbf{K}_1}^{(n)}(\mathbf{X}_1), \Phi_{2, \mathbf{K}_2}^{(n)}(\mathbf{X}_2)) \neq (\mathbf{X}_1, \mathbf{X}_2)] \\ &= \Pr[\psi^{(n)}(\phi_1^{(n)}(\mathbf{X}_1), \phi_2^{(n)}(\mathbf{X}_2)) \neq (\mathbf{X}_1, \mathbf{X}_2)] \\ &= \Pr[(\mathbf{X}_1, \mathbf{X}_2) \notin \mathcal{D}^{(n)}]. \end{aligned}$$

Since the above quantity depends only on $(\phi_1^{(n)}, \phi_2^{(n)}, \psi^{(n)})$, we write the error probability p_e of decoding as

$$\begin{aligned} p_e &= p_e(\phi_1^{(n)}, \phi_2^{(n)}, \psi^{(n)} | p_{X_1 X_2}^n, p_{K_1 K_2}^n) \\ &:= \Pr[(\mathbf{X}_1, \mathbf{X}_2) \notin \mathcal{D}^{(n)}]. \end{aligned}$$

Definition 2: We fix some positive constant ε_0 . For a fixed pair $(\varepsilon, \delta) \in [0, \varepsilon_0] \times (0, 1)$, (R_1, R_2) is (ε, δ) -admissible if there exists a sequence $\{(\Phi_1^{(n)}, \Phi_2^{(n)}, \Psi^{(n)})\}_{n \geq 1}$ such that $\forall \gamma > 0, \exists n_0 = n_0(\gamma) \in \mathbb{N}, \forall n \geq n_0$, we have

$$\begin{aligned} \frac{1}{n} \log |\mathcal{X}_i^{m_i}| &= \frac{m_i}{n} \log |\mathcal{X}_i| \in [R_i - \gamma, R_i + \gamma], i = 1, 2, \\ p_e(\phi_1^{(n)}, \phi_2^{(n)}, \psi^{(n)} | p_{X_1 X_2}^n, p_{K_1 K_2}^n) &\leq \delta, \\ \Delta_{\text{max-MI}}^{(n)}(\Phi_1^{(n)}, \Phi_2^{(n)}, \Psi^{(n)} | p_{X_1 X_2}^n, p_{K_1 K_2}^n) &\leq \varepsilon. \end{aligned}$$

Definition 3: (Reliable and Secure Rate Set) Let $\mathcal{R}(\varepsilon, \delta | p_{X_1 X_2}, p_{K_1 K_2})$ denote the set of all (R_1, R_2) such that (R_1, R_2) is (ε, δ) -admissible. Furthermore, set

$$\mathcal{R}(p_{X_1 X_2}, p_{K_1 K_2}) := \bigcap_{\substack{(\varepsilon, \delta) \in (0, \varepsilon_0] \\ \times (0, 1)}} \mathcal{R}(\varepsilon, \delta | p_{X_1 X_2}, p_{K_1 K_2})$$

We call $\mathcal{R}(p_{X_1 X_2}, p_{K_1 K_2})$ the **reliable and secure rate set**.

B. Strong Converse for the Distributed Source Encryption

To state our results on $\mathcal{R}(\varepsilon, \delta | p_{X_1 X_2}, p_{K_1 K_2})$ for $(\varepsilon, \delta) \in [0, \varepsilon_0] \times (0, 1)$, define the following two regions:

$$\begin{aligned} \mathcal{R}_{\text{sw}}(p_{X_1 X_2}) &:= \{(R_1, R_2) : R_1 \geq H(X_1 | X_2), \\ &\quad R_2 \geq H(X_2 | X_1), \\ &\quad R_1 + R_2 \geq H(X_1 X_2)\}, \\ \mathcal{R}_{\text{key}}(p_{K_1 K_2}) &:= \{(R_1, R_2) : R_1 \leq H(K_1), R_2 \leq H(K_2), \\ &\quad R_1 + R_2 \leq H(K_1 K_2)\}. \end{aligned}$$

Santoso and Oohama [1], [2] proved that the bound $\mathcal{R}_{\text{key}}(p_{K_1 K_2}) \cap \mathcal{R}_{\text{sw}}(p_{X_1 X_2})$ serves as an inner bound of $\mathcal{R}(p_{X_1 X_2}, p_{K_1 K_2})$ in the case where the security criterion is measured by the mutual information $\Delta_{\text{MI}}^{(n)}$. By a simple observation we can see that their post encryption compression scheme yields the same bound in the present case of security criterion measured by $\Delta_{\text{max-MI}}^{(n)}$. Hence we have the following theorem:

Theorem 1: For each $(\varepsilon, \delta) \in (0, \varepsilon_0] \times (0, 1)$, we have

$$\begin{aligned} &\mathcal{R}_{\text{key}}(p_{K_1 K_2}) \cap \mathcal{R}_{\text{sw}}(p_{X_1 X_2}) \\ &\subseteq \mathcal{R}(p_{X_1 X_2}, p_{K_1 K_2}) \subseteq \mathcal{R}(\varepsilon, \delta | p_{X_1 X_2}, p_{K_1 K_2}). \end{aligned}$$

Outline of the proof of this theorem will be given in the next section. We next derive one outer bound by a simple observation based on previous works on the distributed source coding for correlated sources. From the communication scheme we can see that the common key cryptosystem can be regarded as the data compression system, where for each $i = 1, 2$, the encoder $\Phi_i^{(n)}$ and the decoder $\Psi^{(n)}$ can use the common side information \mathbf{K}_i . By the strong converse coding theorem for this data compression system [9], we have that if

$$\begin{aligned} R_1 &< H(X_1 | X_2 K_1 K_2) = H(X_1 | X_2) \text{ or} \\ R_2 &< H(X_2 | X_1 K_1 K_2) = H(X_2 | X_1) \text{ or} \\ R_1 + R_2 &< H(X_1 X_2 | K_1 K_2) = H(X_1 X_2) \end{aligned}$$

then $\forall \tau \in (0, 1), \forall \gamma > 0$, and $\forall \{(\phi_1^{(n)}, \phi_2^{(n)}, \psi^{(n)})\}_{n \geq 1}, \exists n_0 = n_0(\tau, \gamma) \in \mathbb{N}, \forall n \geq n_0$, we have the following:

$$\begin{aligned} \frac{m}{n} \log |\mathcal{X}_i| &\leq R_i + \gamma, i = 1, 2, \\ p_e(\phi_1^{(n)}, \phi_2^{(n)}, \psi^{(n)} | p_{X_1 X_2}^n, p_{K_1 K_2}^n) &\geq 1 - \tau. \end{aligned}$$

Hence we have the following theorem.

Theorem 2: For each $(\varepsilon, \delta) \in (0, \varepsilon_0] \times (0, 1)$, we have

$$\mathcal{R}(\varepsilon, \delta | p_{X_1 X_2}, p_{K_1 K_2}) \subseteq \mathcal{R}_{\text{sw}}(p_{X_1 X_2}).$$

In this paper we prove that for some $\varepsilon_0 > 0$, the set $\mathcal{R}_{\text{key}}(p_{K_1 K_2})$ serves as an outer bound of $\mathcal{R}(\varepsilon, \delta | p_{X_1 X_2}, p_{K_1 K_2})$ for $(\varepsilon, \delta) \in (0, \varepsilon_0] \times (0, 1)$. As an immediate consequence of Proposition 1 part c), we have the following proposition.

Proposition 2: If $(R_1, R_2) \in \mathcal{R}(\varepsilon, \delta | p_{X_1 X_2}, p_{K_1 K_2})$, then we have that $\forall \gamma > 0, \exists n_0(\gamma), \forall n \geq n_0(\gamma)$, we have

$$\begin{aligned} R_i &\leq H(K_i) + \gamma + \frac{\varepsilon}{n}, i = 1, 2, \\ R_1 + R_2 &\leq H(K_1 K_2) + \gamma + \frac{\varepsilon}{n}. \end{aligned}$$

From this proposition we have the following theorem.

Theorem 3: For each $(\varepsilon, \delta) \in (0, \varepsilon_0] \times (0, 1)$, we have

$$\mathcal{R}(\varepsilon, \delta | p_{X_1 X_2}, p_{K_1 K_2}) \subseteq \mathcal{R}_{\text{key}}(p_{K_1 K_2}).$$

Combining Theorems 1, 2, and 3, we establish the following:

Theorem 4: For each $(\varepsilon, \delta) \in (0, \varepsilon_0] \times (0, 1)$, we have

$$\begin{aligned} &\mathcal{R}_{\text{key}}(p_{K_1 K_2}) \cap \mathcal{R}_{\text{sw}}(p_{X_1 X_2}) \\ &= \mathcal{R}(p_{X_1 X_2}, p_{K_1 K_2}) = \mathcal{R}(\varepsilon, \delta | p_{X_1 X_2}, p_{K_1 K_2}). \end{aligned}$$

IV. OUTLINE OF THE PROOF OF THEOREM 1

In this section we outline the proof of Theorem 1. Our construction of $(\Phi_1^{(n)}, \Phi_2^{(n)}, \Psi^{(n)})$ is the same as that of Santoso and Oohama [1], [2] for the post encryption compression scheme.

Let $\phi^{(n)} := (\phi_1^{(n)}, \phi_2^{(n)})$ be a pair of linear mappings $\phi_1^{(n)} : \mathcal{X}_1^n \rightarrow \mathcal{X}_1^{m_1}$ and $\phi_2^{(n)} : \mathcal{X}_2^n \rightarrow \mathcal{X}_2^{m_2}$. For each $i = 1, 2$, we define the mapping $\phi_i^{(n)} : \mathcal{X}_i^n \rightarrow \mathcal{X}_i^{m_i}$ by

$$\phi_i^{(n)}(\mathbf{x}_i) = \mathbf{x}_i A_i \text{ for } \mathbf{x}_i \in \mathcal{X}_i^n, \quad (3)$$

where A_i is a matrix with n rows and m_i columns. For each $i = 1, 2$, entries of A_i are from \mathcal{X}_i . We fix $b_i^{m_i} \in \mathcal{X}_i^{m_i}$, $i = 1, 2$. For each $i = 1, 2$, define the mapping $\varphi_i^{(n)} : \mathcal{X}_i^n \rightarrow \mathcal{X}_i^{m_i}$ by

$$\varphi_i^{(n)}(\mathbf{k}_i) := \phi_i^{(n)}(\mathbf{k}_i) \oplus b_i^{m_i} = \mathbf{k}_i A_i \oplus b_i^{m_i}, \quad (4)$$

for $\mathbf{k}_i \in \mathcal{X}_i^n$. For each $i = 1, 2$, the mapping $\varphi_i^{(n)}$ is called the affine mapping induced by the linear mapping $\phi_i^{(n)}$ and constant vector $b_i^{m_i} \in \mathcal{X}_i^{m_i}$. For each $i = 1, 2$, define $\Phi_i^{(n)}$ by

$$\Phi_i^{(n)}(\mathbf{k}_i, \mathbf{x}_i) = \varphi_i^{(n)}(\mathbf{k}_i \oplus \mathbf{x}_i).$$

By the definition (4) of $\varphi_i^{(n)}$, $i = 1, 2$, we have

$$\begin{aligned} \Phi_i^{(n)}(\mathbf{k}_i, \mathbf{x}_i) &= \varphi_i^{(n)}(\mathbf{x}_i \oplus \mathbf{k}_i) \\ &= (\mathbf{x}_i \oplus \mathbf{k}_i) A_i \oplus b_i^{m_i} = \mathbf{x}_i A_i \oplus (\mathbf{k}_i A_i \oplus b_i^{m_i}) \\ &= \phi_i^{(n)}(\mathbf{x}_i) \oplus \varphi_i^{(n)}(\mathbf{k}_i), \text{ for } \mathbf{x}_i, \mathbf{k}_i \in \mathcal{X}_i^n. \end{aligned} \quad (5)$$

Set $\varphi^{(n)} := (\varphi_1^{(n)}, \varphi_2^{(n)})$. Next, let $\psi^{(n)}$ be the corresponding joint decoder for $\phi^{(n)}$ such that $\psi^{(n)} : \mathcal{X}_1^{m_1} \times \mathcal{X}_2^{m_2} \rightarrow \mathcal{X}_1^n \times \mathcal{X}_2^n$. Note that $\psi^{(n)}$ does not have a linear structure in general.

Description of Proposed procedure : We describe the procedure of our privacy amplified system as follows.

- 1) *Encoding of Ciphertexts:* First, we use $\varphi_1^{(n)}$ and $\varphi_2^{(n)}$ to encode the ciphertexts $\mathbf{X}_1 \oplus \mathbf{K}_1$ and $\mathbf{X}_2 \oplus \mathbf{K}_2$. Let $C_i^{m_i} = \varphi_i^{(n)}(\mathbf{X}_i \oplus \mathbf{K}_i)$ for $i = 1, 2$. By the affine structure (5) of encoders we have that for each $i = 1, 2$,

$$\begin{aligned} \Phi_i^{(n)}(\mathbf{K}_i, \mathbf{X}_i) &= C_i^{m_i} = \varphi_i^{(n)}(\mathbf{X}_i \oplus \mathbf{K}_i) \\ &= \phi_i^{(n)}(\mathbf{X}_i) \oplus \varphi_i^{(n)}(\mathbf{K}_i) = \tilde{X}_i^{m_i} \oplus \tilde{K}_i^{m_i}, \end{aligned} \quad (6)$$

where $\tilde{X}_i^{m_i} := \phi_i^{(n)}(\mathbf{X}_i)$, $\tilde{K}_i^{m_i} := \varphi_i^{(n)}(\mathbf{K}_i)$.

- 2) *Decoding at Joint Sink Node D:* First, using the pair of linear encoders $(\varphi_1^{(n)}, \varphi_2^{(n)})$, D encodes the keys $(\mathbf{K}_1, \mathbf{K}_2)$ which are received through private channel into $(\tilde{K}_1^{m_1}, \tilde{K}_2^{m_2}) = (\varphi_1^{(n)}(\mathbf{K}_1), \varphi_2^{(n)}(\mathbf{K}_2))$. Receiving $(C_1^{m_1}, C_2^{m_2})$ from public communication channel, D computes $\tilde{X}_i^{m_i}$, $i = 1, 2$ in the following way. From (6), we have that for each $i = 1, 2$, the decoder D can obtain $\tilde{X}_i^{m_i} = \phi_i^{(n)}(\mathbf{X}_i)$ by subtracting $\tilde{K}_i^{m_i} = \varphi_i^{(n)}(\mathbf{K}_i)$ from $C_i^{m_i}$. Finally, D outputs $(\hat{\mathbf{X}}_1, \hat{\mathbf{X}}_2)$ by applying the joint decoder $\psi^{(n)}$ to $(\tilde{X}_1^{m_1}, \tilde{X}_2^{m_2})$ as follows:

$$\begin{aligned} (\hat{\mathbf{X}}_1, \hat{\mathbf{X}}_2) &= (\psi^{(n)}(\tilde{X}_1^{m_1}, \tilde{X}_2^{m_2})) \\ &= (\psi^{(n)}(\phi_1^{(n)}(\mathbf{X}_1), \phi_2^{(n)}(\mathbf{X}_2))). \end{aligned} \quad (7)$$

We summarize the above argument. For $(\mathbf{K}_1, \mathbf{K}_2)$ and $(C_1^{m_1}, C_2^{m_2})$, define $\Psi^{(n)}$ by

$$\begin{aligned} \Psi^{(n)}(\mathbf{K}_1, \mathbf{K}_2, C_1^{m_1}, C_2^{m_2}) &= \Psi_{\mathbf{K}_1, \mathbf{K}_2}^{(n)}(C_1^{m_1}, C_2^{m_2}) \\ &:= \psi^{(n)}(C_1^{m_1} \ominus \tilde{K}_1^{m_1}, C_2^{m_2} \ominus \tilde{K}_2^{m_2}) \\ &= \psi^{(n)}(\tilde{X}_1^{m_1}, \tilde{X}_2^{m_2}). \end{aligned}$$

By the above definition and $C_i^{m_i} = \Phi_{i, \mathbf{K}_i}^{(n)}(\mathbf{X}_i)$, $i = 1, 2$, we have

$$\begin{aligned} \Psi_{\mathbf{K}_1, \mathbf{K}_2}^{(n)}(\Phi_{1, \mathbf{K}_1}^{(n)}(\mathbf{X}_1), \Phi_{2, \mathbf{K}_2}^{(n)}(\mathbf{X}_2)) \\ = \psi^{(n)}(\tilde{X}_1^{m_1}, \tilde{X}_2^{m_2}) = \psi^{(n)}(\phi_1^{(n)}(\mathbf{X}_1), \phi_2^{(n)}(\mathbf{X}_2)). \end{aligned}$$

Hence we have the condition which $(\Phi_1^{(n)}, \Phi_2^{(n)}, \Psi^{(n)})$ must satisfy.

In this paper, we use the *minimum entropy decoder* for our joint decoder $\psi^{(n)}$.

Minimum Entropy Decoder: For $\phi_i^{(n)}(\mathbf{x}_i) = \tilde{x}_i^{m_i}$, $i = 1, 2$, $\psi^{(n)} : \mathcal{X}_1^{m_1} \times \mathcal{X}_2^{m_2} \rightarrow \mathcal{X}_1^n \times \mathcal{X}_2^n$ is defined as follows:

$$\psi^{(n)}(\tilde{x}_1^{m_1}, \tilde{x}_2^{m_2}) := \begin{cases} (\hat{\mathbf{x}}_1, \hat{\mathbf{x}}_2) \text{ if } \phi_i^{(n)}(\hat{\mathbf{x}}_i) = \tilde{x}_i^{m_i}, i = 1, 2, \\ \text{and } H(\hat{\mathbf{x}}_1 \hat{\mathbf{x}}_2) < H(\tilde{\mathbf{x}}_1 \tilde{\mathbf{x}}_2) \\ \text{for all } (\tilde{\mathbf{x}}_1, \tilde{\mathbf{x}}_2) \text{ such that} \\ \phi_i^{(n)}(\tilde{\mathbf{x}}_i) = \tilde{x}_i^{m_i}, i = 1, 2, \\ \text{and } (\tilde{\mathbf{x}}_1, \tilde{\mathbf{x}}_2) \neq (\hat{\mathbf{x}}_1, \hat{\mathbf{x}}_2), \\ \text{arbitrary if there is no such } (\hat{\mathbf{x}}_1, \hat{\mathbf{x}}_2) \in \mathcal{X}_1^n \times \mathcal{X}_2^n. \end{cases}$$

Our privacy amplified system described above is illustrated in Fig. 3.

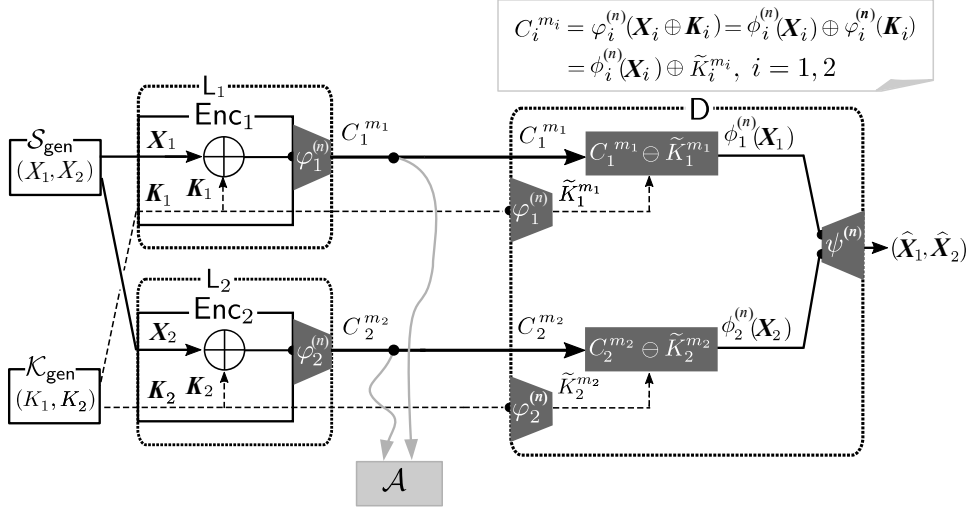

Fig. 3. Our proposed solution: linear encoders as privacy amplifiers.

Evaluations of the reliability and security: On the error probability p_e of decoding we have

$$\begin{aligned}
 p_e &= \Pr[\Psi^{(n)}(\mathbf{K}_1, \mathbf{K}_2, \phi_1^{(n)}(\mathbf{K}_1, \mathbf{X}_1), \phi_2^{(n)}(\mathbf{K}_2, \mathbf{X}_2)) \\
 &\quad \neq (\mathbf{X}_1, \mathbf{X}_2)] \\
 &= \Pr[\Psi_{\mathbf{K}_1, \mathbf{K}_2}^{(n)}(\Phi_{1, \mathbf{K}_1}^{(n)}(\mathbf{X}_1), \Phi_{2, \mathbf{K}_2}^{(n)}(\mathbf{X}_2)) \neq (\mathbf{X}_1, \mathbf{X}_2)] \\
 &= \Pr[\psi^{(n)}(\phi_1^{(n)}(\mathbf{X}_1), \phi_2^{(n)}(\mathbf{X}_2)) \neq (\mathbf{X}_1, \mathbf{X}_2)].
 \end{aligned}$$

We have the following upper bound of $\Delta_{\max\text{-MI}}^{(n)}(\Phi_1^{(n)}, \Phi_2^{(n)}, \Psi^{(n)} | p_{\mathbf{K}_1 \mathbf{K}_2}^n)$.

Lemma 2: For the proposed construction of $(\Phi_1^{(n)}, \Phi_2^{(n)}, \Psi^{(n)})$, we have

$$\begin{aligned}
 &\Delta_{\max\text{-MI}}^{(n)}(\Phi_1^{(n)}, \Phi_2^{(n)}, \Psi^{(n)} | p_{\mathbf{K}_1 \mathbf{K}_2}^n) \\
 &\leq \bar{\Delta}_{\max\text{-MI}}^{(n)}(\Phi_1^{(n)}, \Phi_2^{(n)} | p_{\mathbf{K}_1 \mathbf{K}_2}^n) \\
 &\leq m_1 \log |\mathcal{X}_1| + m_2 \log |\mathcal{X}_2| - H(\tilde{K}_1^{m_1} \tilde{K}_2^{m_2}) \\
 &= D(p_{\tilde{K}_1^{m_1} \tilde{K}_2^{m_2}} \| p_{U_1^{m_1} U_2^{m_2}}).
 \end{aligned}$$

Here $p_{U_1^{m_1} U_2^{m_2}}$ is the uniform distribution over $\mathcal{X}_1^{m_1} \times \mathcal{X}_2^{m_2}$.

Proof: By Proposition 1 part a), it suffices to prove the upper bound of $\bar{\Delta}_{\max\text{-MI}}^{(n)}(\Phi_1^{(n)}, \Phi_2^{(n)} | p_{\mathbf{K}_1 \mathbf{K}_2}^n)$. For the proposed construction of $(\Phi_1^{(n)}, \Phi_2^{(n)})$, we have

$$\bar{C}_i^{m_i} = \tilde{K}_i^{m_i} \oplus \phi_i^{(n)}(\bar{\mathbf{X}}_i), i = 1, 2. \quad (8)$$

Then we have the following chain of inequalities:

$$\begin{aligned}
 &I(\bar{C}_1^{m_1} \bar{C}_2^{m_2}; \bar{\mathbf{X}}_1 \bar{\mathbf{X}}_2) \\
 &= H(\bar{C}_1^{m_1} \bar{C}_2^{m_2}) - H(\bar{C}_1^{m_1} \bar{C}_2^{m_2} | \bar{\mathbf{X}}_1 \bar{\mathbf{X}}_2) \\
 &\leq m_1 \log |\mathcal{X}_1| + m_2 \log |\mathcal{X}_2| - H(\bar{C}_1^{m_1} \bar{C}_2^{m_2} | \bar{\mathbf{X}}_1 \bar{\mathbf{X}}_2) \\
 &\stackrel{(a)}{=} m_1 \log |\mathcal{X}_1| + m_2 \log |\mathcal{X}_2| \\
 &\quad - H(\tilde{K}_1^{m_1} \oplus \phi_1^{(n)}(\bar{\mathbf{X}}_1), \tilde{K}_2^{m_2} \oplus \phi_2^{(n)}(\bar{\mathbf{X}}_2) | \bar{\mathbf{X}}_1 \bar{\mathbf{X}}_2) \\
 &= m_1 \log |\mathcal{X}_1| + m_2 \log |\mathcal{X}_2| - H(\tilde{K}_1^{m_1} \tilde{K}_2^{m_2} | \bar{\mathbf{X}}_1 \bar{\mathbf{X}}_2) \\
 &\stackrel{(b)}{=} m_1 \log |\mathcal{X}_1| + m_2 \log |\mathcal{X}_2| - H(\tilde{K}_1^{m_1} \tilde{K}_2^{m_2}) \\
 &= D(p_{\tilde{K}_1^{m_1} \tilde{K}_2^{m_2}} \| p_{U_1^{m_1} U_2^{m_2}}). \quad (9)
 \end{aligned}$$

Step (a) follows from (8). Step (b) follows from $(\bar{\mathbf{X}}_1, \bar{\mathbf{X}}_2) \perp (\mathbf{K}_1, \mathbf{K}_2)$. Since (9) holds for any $(\bar{\mathbf{X}}_1, \bar{\mathbf{X}}_2)$, we have the upper bound of $\bar{\Delta}_{\max\text{-MI}}^{(n)}(\Phi_1^{(n)}, \Phi_2^{(n)} | p_{\mathbf{K}_1 \mathbf{K}_2}^n)$ in Lemma 2. ■

According to Santoso and Oohama [2], $\exists \{(\Phi_1^{(n)}, \Phi_2^{(n)}, \Psi^{(n)})\}_{n \geq 1}$ such that for any $(p_{X_1 X_2}, p_{K_1 K_2})$ satisfying

$$\begin{aligned}
 &\left(\frac{m_1}{n} \log |\mathcal{X}_1|, \frac{m_2}{n} \log |\mathcal{X}_2| \right) \\
 &\in \mathcal{R}_{\text{key}}(p_{K_1 K_2}) \cap \mathcal{R}_{\text{sw}}(p_{X_1 X_2}),
 \end{aligned}$$

the two quantities

$$\begin{aligned}
 &\Pr[\psi^{(n)}(\phi_1^{(n)}(\mathbf{X}_1), \phi_2^{(n)}(\mathbf{X}_2)) \neq (\mathbf{X}_1, \mathbf{X}_2)] \text{ and} \\
 &D(p_{\tilde{K}_1^{m_1} \tilde{K}_2^{m_2}} \| p_{U_1^{m_1} U_2^{m_2}})
 \end{aligned}$$

decay exponentially as n tends to infinity. Hence we have Theorem 1.

A. Proof of Property 1

Proof of Property 1: We have the following:

$$\begin{aligned} \mathcal{D}^{(n)} &\stackrel{(a)}{=} \{(\mathbf{x}_1, \mathbf{x}_2) = \psi^{(n)}(\tilde{x}_1^{m_1}, \tilde{x}_2^{m_2}) : \\ &\quad (\tilde{x}_1^{m_1}, \tilde{x}_2^{m_2}) \in \phi_1^{(n)}(\mathcal{X}_1^n) \times \phi_2^{(n)}(\mathcal{X}_2^n)\} \\ &\stackrel{(b)}{=} \{(\mathbf{x}_1, \mathbf{x}_2) = \psi^{(n)}(\tilde{x}_1^{m_1}, \tilde{x}_2^{m_2}) : \\ &\quad (\tilde{x}_1^{m_1}, \tilde{x}_2^{m_2}) \in \mathcal{X}_1^{m_1} \times \mathcal{X}_2^{m_2}\}. \end{aligned} \quad (10)$$

Step (a) follows from that every pair $(\tilde{x}_1^{m_1}, \tilde{x}_2^{m_2}) \in \phi_1^{(n)}(\mathcal{X}_1^n) \times \phi_2^{(n)}(\mathcal{X}_2^n)$ uniquely determines $(\mathbf{x}_1, \mathbf{x}_2) \in \mathcal{D}^{(n)}$. Step (b) follows from that $\phi_i^{(n)}, i = 1, 2$ are surjective. Since $\psi^{(n)} : \mathcal{X}_1^{m_1} \times \mathcal{X}_2^{m_2} \rightarrow \mathcal{X}_1^n \times \mathcal{X}_2^n$ is a one-to-one mapping and (10), we have $|\mathcal{D}^{(n)}| = |\mathcal{X}_1^{m_1}| |\mathcal{X}_2^{m_2}|$. ■

B. Proof of Property 2

We first prove the part a) and next prove the part b).

Proof of Property 2 part a): Under $(\mathbf{x}_1, \mathbf{x}_2), (\mathbf{x}'_1, \mathbf{x}'_2) \in \mathcal{D}^{(n)}$ and $(\mathbf{x}_1, \mathbf{x}_2) \neq (\mathbf{x}'_1, \mathbf{x}'_2)$, we assume that

$$(\Phi_{1, \mathbf{k}_1}^{(n)}(\mathbf{x}_1), \Phi_{2, \mathbf{k}_2}^{(n)}(\mathbf{x}_2)) = (\Phi_{1, \mathbf{k}_1}^{(n)}(\mathbf{x}'_1), \Phi_{2, \mathbf{k}_2}^{(n)}(\mathbf{x}'_2)). \quad (11)$$

Then we have the following

$$\begin{aligned} (\mathbf{x}_1, \mathbf{x}_2) &\stackrel{(a)}{=} \psi^{(n)}(\phi_1^{(n)}(\mathbf{k}_1), \phi_2^{(n)}(\mathbf{k}_2)), \\ &\stackrel{(b)}{=} \Psi_{\mathbf{k}_1, \mathbf{k}_2}^{(n)}(\Phi_{1, \mathbf{k}_1}^{(n)}(\mathbf{x}_1), \Phi_{2, \mathbf{k}_2}^{(n)}(\mathbf{x}_2)) \\ &\stackrel{(c)}{=} \Psi_{\mathbf{k}_1, \mathbf{k}_2}^{(n)}(\Phi_{1, \mathbf{k}_1}^{(n)}(\mathbf{x}'_1), \Phi_{2, \mathbf{k}_2}^{(n)}(\mathbf{x}'_2)) \\ &\stackrel{(d)}{=} \psi^{(n)}(\phi_1^{(n)}(\mathbf{x}'_1), \phi_2^{(n)}(\mathbf{x}'_2)) \stackrel{(e)}{=} (\mathbf{x}'_1, \mathbf{x}'_2). \end{aligned} \quad (12)$$

Steps (a) and (e) follow from the definition of $\mathcal{D}^{(n)}$. Step (c) follows from 11. Steps (b) and (d) follow from the relationship between $(\phi_1^{(n)}, \phi_2^{(n)}, \psi^{(n)})$ and $(\Phi_{1, \mathbf{k}_1}^{(n)}, \Phi_{2, \mathbf{k}_2}^{(n)}, \Psi_{\mathbf{k}_1, \mathbf{k}_2}^{(n)})$. The equality (12) contradicts the first assumption. Hence we must have Property 2 part a). ■

Proof of Property 2 part b): We assume that $\exists(\mathbf{k}_1, \mathbf{k}_2)$ and $\exists(c_1^{m_1}, c_2^{m_2})$ such that $\forall(\mathbf{x}_1, \mathbf{x}_2) \in \mathcal{D}^{(n)}$, $(\Phi_{1, \mathbf{k}_1}^{(n)}(\mathbf{x}_1), \Phi_{2, \mathbf{k}_2}^{(n)}(\mathbf{x}_2)) \neq (c_1^{m_1}, c_2^{m_2})$. Set

$$\mathcal{B} := \{(\Phi_{1, \mathbf{k}_1}^{(n)}(\mathbf{x}_1), \Phi_{2, \mathbf{k}_2}^{(n)}(\mathbf{x}_2)) : (\mathbf{x}_1, \mathbf{x}_2) \in \mathcal{D}^{(n)}\}.$$

Then by the above assumption we have

$$\mathcal{B} \subseteq \mathcal{X}_1^{m_1} \times \mathcal{X}_2^{m_2} - \{(c_1^{m_1}, c_2^{m_2})\}. \quad (13)$$

On the other hand we have

$$\begin{aligned} &\Psi_{\mathbf{k}_1, \mathbf{k}_2}^{(n)}(\mathcal{B}) \\ &= \{ \Psi_{\mathbf{k}_1, \mathbf{k}_2}^{(n)}(\Phi_{1, \mathbf{k}_1}^{(n)}(\mathbf{x}_1), \Phi_{2, \mathbf{k}_2}^{(n)}(\mathbf{x}_2)) : (\mathbf{x}_1, \mathbf{x}_2) \in \mathcal{D}^{(n)} \} \\ &= \{ \psi^{(n)}(\phi_1^{(n)}(\mathbf{x}_1), \phi_2^{(n)}(\mathbf{x}_2)) : (\mathbf{x}_1, \mathbf{x}_2) \in \mathcal{D}^{(n)} \} = \mathcal{D}^{(n)}, \end{aligned}$$

which together with that $\Psi_{\mathbf{k}_1, \mathbf{k}_2}^{(n)} : \mathcal{X}_1^{m_1} \times \mathcal{X}_2^{m_2} \rightarrow \mathcal{X}_1^n \times \mathcal{X}_2^n$ is a one-to-one mapping yields that

$$|\mathcal{B}| = |\Psi_{\mathbf{k}_1, \mathbf{k}_2}^{(n)}(\mathcal{B})| = |\mathcal{D}^{(n)}| = |\mathcal{X}_1^{m_1}| |\mathcal{X}_2^{m_2}|.$$

The above equality contradicts (13). Hence we must have that $\forall(\mathbf{k}_1, \mathbf{k}_2), \forall(c_1^{m_1}, c_2^{m_2}), \exists(\mathbf{x}_1, \mathbf{x}_2) \in \mathcal{D}^{(n)}$ such that $\Phi_{i, \mathbf{k}_i}^{(n)}(\mathbf{x}_i) = c_i^{m_i}, i = 1, 2$. ■

C. Proof of Lemma 1

In this appendix we prove Lemma 1.

Proof of Lemma 1: By definition we have

$$\begin{aligned} &p_{C_1^{m_1} C_2^{m_2} | \mathbf{X}_1 \mathbf{X}_2}(c_1^{m_1}, c_2^{m_2} | \mathbf{x}_1, \mathbf{x}_2) \\ &= \Pr \left\{ (\mathbf{K}_1, \mathbf{K}_2) \in \mathcal{A}_{\mathbf{x}_1, \mathbf{x}_2}(c_1^{m_1}, c_2^{m_2}) \mid \mathbf{X}_1 = \mathbf{x}_1, \mathbf{X}_2 = \mathbf{x}_2 \right\} \\ &\stackrel{(a)}{=} \Pr \{ (\mathbf{K}_1, \mathbf{K}_2) \in \mathcal{A}_{\mathbf{x}_1, \mathbf{x}_2}(c_1^{m_1}, c_2^{m_2}) \}. \end{aligned} \quad (14)$$

Step (a) follows from $(\mathbf{K}_1, \mathbf{K}_2) \perp (\mathbf{X}_1, \mathbf{X}_2)$. On the other hand, Property 2 part a) implies that

$$\begin{aligned} &\mathcal{A}_{\mathbf{x}_1, \mathbf{x}_2}(c_1^{m_1}, c_2^{m_2}) \cap \mathcal{A}_{\mathbf{x}'_1, \mathbf{x}'_2}(c_1^{m_1}, c_2^{m_2}) = \emptyset \\ &\text{for } (\mathbf{x}_1, \mathbf{x}_2) \neq (\mathbf{x}'_1, \mathbf{x}'_2) \in \mathcal{D}^{(n)}. \end{aligned} \quad (15)$$

Furthermore, Property 2 part b) implies that

$$\bigcup_{(\mathbf{x}_1, \mathbf{x}_2) \in \mathcal{D}^{(n)}} \mathcal{A}_{\mathbf{x}_1, \mathbf{x}_2}(c_1^{m_1}, c_2^{m_2}) = \mathcal{X}_1^{m_1} \times \mathcal{X}_2^{m_2}. \quad (16)$$

From (14), we have the following chain of equalities:

$$\begin{aligned} &\sum_{(\mathbf{x}_1, \mathbf{x}_2) \in \mathcal{D}^{(n)}} p_{C_1^{m_1} C_2^{m_2} | \mathbf{X}_1 \mathbf{X}_2}(c_1^{m_1}, c_2^{m_2} | \mathbf{x}_1, \mathbf{x}_2) \\ &\stackrel{(a)}{=} \Pr \left\{ (\mathbf{K}_1, \mathbf{K}_2) \in \bigcup_{(\mathbf{x}_1, \mathbf{x}_2) \in \mathcal{D}^{(n)}} \mathcal{A}_{\mathbf{x}_1, \mathbf{x}_2}(c_1^{m_1}, c_2^{m_2}) \right\} \stackrel{(b)}{=} 1. \end{aligned}$$

Step (a) follows from (15). Step (b) follows from (16). ■

D. Proof of Proposition 1

In this appendix we prove Proposition 1.

Proof of Proposition 1: The part a) is obvious. We first prove the part b). Using the quantities

$$\begin{aligned} &\Gamma_{\mathbf{K}_1 \mathbf{K}_2, (\mathbf{x}_1, \mathbf{x}_2)}(c_1^{m_1}, c_2^{m_2}), \\ &(\mathbf{x}_1, \mathbf{x}_2, c_1^{m_1}, c_2^{m_2}) \in \mathcal{X}_1^n \times \mathcal{X}_2^n \times \mathcal{X}^{m_1} \times \mathcal{X}^{m_2}, \end{aligned}$$

components $p_{C_1^{m_1} C_2^{m_2} | \mathbf{X}_1 \mathbf{X}_2}(c_1^{m_1}, c_2^{m_2})$ of the joint distribution $p_{C_1^{m_1} C_2^{m_2}}$ can be computed as

$$\begin{aligned} &p_{C_1^{m_1} C_2^{m_2}}(c_1^{m_1}, c_2^{m_2}) \\ &= \sum_{(\mathbf{x}_1, \mathbf{x}_2)} p_{\mathbf{X}_1 \mathbf{X}_2}(\mathbf{x}_1, \mathbf{x}_2) \Gamma_{\mathbf{K}_1 \mathbf{K}_2, (\mathbf{x}_1, \mathbf{x}_2)}(c_1^{m_1}, c_2^{m_2}). \end{aligned}$$

Set

$$\begin{aligned} &\Gamma_{\mathbf{K}_1 \mathbf{K}_2}^{(p_{\mathbf{X}_1 \mathbf{X}_2})}(c_1^{m_1}, c_2^{m_2}) \\ &= \sum_{(\mathbf{x}_1, \mathbf{x}_2)} p_{\mathbf{X}_1 \mathbf{X}_2}(\mathbf{x}_1, \mathbf{x}_2) \Gamma_{\mathbf{K}_1 \mathbf{K}_2, (\mathbf{x}_1, \mathbf{x}_2)}(c_1^{m_1}, c_2^{m_2}) \\ &= p_{C_1^{m_1} C_2^{m_2}}(c_1^{m_1}, c_2^{m_2}). \end{aligned}$$

Furthermore, set

$$\begin{aligned} &\Gamma_{\mathbf{K}_1 \mathbf{K}_2}^{(p_{\mathbf{X}_1 \mathbf{X}_2})} := \left\{ \Gamma_{\mathbf{K}_1 \mathbf{K}_2}^{(p_{\mathbf{X}_1 \mathbf{X}_2})}(c_1^{m_1}, c_2^{m_2}) \right\}_{(c_1^{m_1}, c_2^{m_2}) \in \mathcal{X}_1^{m_1} \times \mathcal{X}_2^{m_2}} \\ &= p_{C_1^{m_1} C_2^{m_2}}. \end{aligned}$$

Using $\Gamma_{\mathbf{K}_1\mathbf{K}_2,(\mathbf{x}_1,\mathbf{x}_2)}, (\mathbf{x}_1, \mathbf{x}_2) \in \mathcal{X}_1^n \times \mathcal{X}_2^n$ and $\Gamma_{\mathbf{K}_1\mathbf{K}_2}^{(p_{\mathbf{X}_1\mathbf{X}_2})}$, we compute $\Delta_{\text{MI}}^{(n)}$ to obtain

$$\begin{aligned} \Delta_{\text{MI}}^{(n)} &= I(C_1^{m_1} C_2^{m_2}; \mathbf{X}_1 \mathbf{X}_2) = \sum_{\substack{(\mathbf{x}_1, \mathbf{x}_2) \\ \in \mathcal{X}_1^n \times \mathcal{X}_2^n}} p_{\mathbf{X}_1 \mathbf{X}_2}(\mathbf{x}_1, \mathbf{x}_2) \\ &\quad \times D\left(\Gamma_{\mathbf{K}_1\mathbf{K}_2,(\mathbf{x}_1,\mathbf{x}_2)} \left\| \Gamma_{\mathbf{K}_1\mathbf{K}_2}^{(p_{\mathbf{X}_1\mathbf{X}_2})}\right.\right) \\ &\geq \sum_{(\mathbf{x}_1, \mathbf{x}_2) \in \mathcal{D}^{(n)}} p_{\mathbf{X}_1 \mathbf{X}_2}(\mathbf{x}_1, \mathbf{x}_2) \\ &\quad \times D\left(\Gamma_{\mathbf{K}_1\mathbf{K}_2,(\mathbf{x}_1,\mathbf{x}_2)} \left\| \Gamma_{\mathbf{K}_1\mathbf{K}_2}^{(p_{\mathbf{X}_1\mathbf{X}_2})}\right.\right). \end{aligned} \quad (17)$$

By the assumption $\mathcal{D}^{(n)} \subseteq \text{Supp}^n(p_{\mathbf{X}_1\mathbf{X}_2})$, we have that

$$\begin{aligned} p_{\mathbf{X}_1 \mathbf{X}_2}(\mathbf{x}_1, \mathbf{x}_2) &= \prod_{t=1}^n p_{X_1 X_2}(x_{1,t}, x_{2,t}) > 0, \\ \forall (\mathbf{x}_1, \mathbf{x}_2) \in \mathcal{D}^{(n)}. \end{aligned} \quad (18)$$

Now we suppose that $\Delta_{\text{MI}}^{(n)} = 0$. Then from (17) and (18), we have

$$\begin{aligned} \Gamma_{\mathbf{K}_1\mathbf{K}_2,(\mathbf{x}_1,\mathbf{x}_2)} &= \Gamma_{\mathbf{K}_1\mathbf{K}_2,(\mathbf{x}_1^*, \mathbf{x}_2^*)} = \Gamma_{\mathbf{K}_1\mathbf{K}_2}^{(p_{\mathbf{X}_1\mathbf{X}_2})}, \\ \forall (\mathbf{x}_1, \mathbf{x}_2) \in \mathcal{D}^{(n)}, \end{aligned} \quad (19)$$

where $(\mathbf{x}_1^*, \mathbf{x}_2^*)$ is an element of $\mathcal{D}^{(n)}$. Let $(\bar{\mathbf{X}}_{1,\text{opt}}, \bar{\mathbf{X}}_{2,\text{opt}})$ be the optimal random variable, the distribution $p_{\bar{\mathbf{X}}_{1,\text{opt}}\bar{\mathbf{X}}_{2,\text{opt}}}$ of which attains the maximum in the definition of $\Delta_{\text{max-MI}}^{(n)}$. We set $\bar{C}_{i,\text{opt}}^m = \Phi_i^{(n)}(\mathbf{K}_i, \bar{\mathbf{X}}_{i,\text{opt}})$, $i = 1, 2$. By definition we have

$$\Delta_{\text{max-MI}}^{(n)} = I(\bar{C}_{1,\text{opt}}^{m_1} \bar{C}_{2,\text{opt}}^{m_2}; \bar{\mathbf{X}}_{1,\text{opt}} \bar{\mathbf{X}}_{2,\text{opt}}).$$

Using (19), we compute $\Gamma_{\mathbf{K}_1\mathbf{K}_2}^{(p_{\bar{\mathbf{X}}_{1,\text{opt}}\bar{\mathbf{X}}_{2,\text{opt}}})}(c_1^{m_1}, c_2^{m_2})$, $(c_1^{m_1}, c_2^{m_2}) \in \mathcal{X}_1^{m_1} \times \mathcal{X}_2^{m_2}$ to obtain

$$\begin{aligned} &\Gamma_{\mathbf{K}_1\mathbf{K}_2}^{(p_{\bar{\mathbf{X}}_{1,\text{opt}}\bar{\mathbf{X}}_{2,\text{opt}}})}(c_1^{m_1}, c_2^{m_2}) \\ &= \sum_{(\mathbf{x}_1, \mathbf{x}_2) \in \mathcal{D}^{(n)}} p_{\bar{\mathbf{X}}_{1,\text{opt}}\bar{\mathbf{X}}_{2,\text{opt}}}(\mathbf{x}_1, \mathbf{x}_2) \\ &\quad \times \Gamma_{\mathbf{K}_1\mathbf{K}_2,(\mathbf{x}_1,\mathbf{x}_2)}(c_1^{m_1}, c_2^{m_2}) = \Gamma_{\mathbf{K}_1\mathbf{K}_2,(\mathbf{x}_1^*, \mathbf{x}_2^*)}(c_1^{m_1}, c_2^{m_2}). \end{aligned}$$

Hence we have

$$\begin{aligned} \Gamma_{\mathbf{K}_1\mathbf{K}_2}^{(p_{\bar{\mathbf{X}}_{1,\text{opt}}\bar{\mathbf{X}}_{2,\text{opt}}})}(c_1^{m_1}, c_2^{m_2}) &= \Gamma_{\mathbf{K}_1\mathbf{K}_2,(\mathbf{x}_1^*, \mathbf{x}_2^*)}(c_1^{m_1}, c_2^{m_2}) \\ &= \Gamma_{\mathbf{K}_1\mathbf{K}_2,(\mathbf{x}_1, \mathbf{x}_2)}(c_1^{m_1}, c_2^{m_2}), \forall (\mathbf{x}_1, \mathbf{x}_2) \in \mathcal{D}^{(n)}. \end{aligned} \quad (20)$$

From (20), we have

$$\begin{aligned} \Delta_{\text{max-MI}}^{(n)} &= I(\bar{C}_{1,\text{opt}}^{m_1} \bar{C}_{2,\text{opt}}^{m_2}; \bar{\mathbf{X}}_{1,\text{opt}} \bar{\mathbf{X}}_{2,\text{opt}}) \\ &= \sum_{(\mathbf{x}_1, \mathbf{x}_2) \in \mathcal{D}^{(n)}} p_{\bar{\mathbf{X}}_{1,\text{opt}}\bar{\mathbf{X}}_{2,\text{opt}}}(\mathbf{x}_1, \mathbf{x}_2) \\ &\quad \times D\left(\Gamma_{\mathbf{K}_1\mathbf{K}_2,(\mathbf{x}_1,\mathbf{x}_2)} \left\| \Gamma_{\mathbf{K}_1\mathbf{K}_2}^{(p_{\bar{\mathbf{X}}_{1,\text{opt}}\bar{\mathbf{X}}_{2,\text{opt}}})}\right.\right) = 0. \end{aligned}$$

We next prove the part c). Let $(\check{\mathbf{X}}_1, \check{\mathbf{X}}_2)$ be a pair of uniformly distributed random vectors over $\mathcal{D}^{(n)}$. Set $\check{C}_i^{m_i} := \Phi_{i,\mathbf{K}_i}(\check{\mathbf{X}}_i)$, $i = 1, 2$. We claim that $(\check{C}_1^{m_1}, \check{C}_2^{m_2})$ is the

uniformly distributed random pair over $\mathcal{X}_1^{m_1} \times \mathcal{X}_2^{m_2}$. In fact for each $(c_1^{m_1}, c_2^{m_2}) \in \mathcal{X}_1^{m_1} \times \mathcal{X}_2^{m_2}$, we have the following chain of equalities:

$$\begin{aligned} &p_{\check{C}_1^{m_1} \check{C}_2^{m_2}}(c_1^{m_1}, c_2^{m_2}) \\ &= \sum_{(\mathbf{x}_1, \mathbf{x}_2) \in \mathcal{D}^{(n)}} p_{\check{C}_1^{(m_1)} \check{C}_2^{(m_2)} | \check{\mathbf{X}}_1 \check{\mathbf{X}}_2}(c_1^{m_1}, c_2^{m_2} | \mathbf{x}_1, \mathbf{x}_2) \\ &\quad \times \frac{1}{|\mathcal{X}_1^{m_1}| |\mathcal{X}_2^{m_2}|} \\ &= \frac{1}{|\mathcal{X}_1^{m_1}| |\mathcal{X}_2^{m_2}|} \sum_{(\mathbf{x}_1, \mathbf{x}_2) \in \mathcal{D}^{(n)}} \Gamma_{\mathbf{K}_1\mathbf{K}_2,(\mathbf{x}_1,\mathbf{x}_2)}(c_1^{m_1}, c_2^{m_2}) \\ &\stackrel{(a)}{=} \frac{1}{|\mathcal{X}_1^{m_1}| |\mathcal{X}_2^{m_1}|}. \end{aligned} \quad (21)$$

Step (a) follows from Lemma 1. Since we have (21) for every $(c_1^{m_1}, c_2^{m_2}) \in \mathcal{X}_1^{m_1} \times \mathcal{X}_2^{m_2}$, we have that $(\check{C}_1^{m_1}, \check{C}_2^{m_2})$ is the uniformly distributed random pair over $\mathcal{X}_1^{m_1} \times \mathcal{X}_2^{m_2}$. We have the following chain of inequalities:

$$\begin{aligned} \Delta_{\text{max-MI}}^{(n)} &\geq I(\check{C}_1^{m_1} \check{C}_2^{m_2}; \check{\mathbf{X}}_1 \check{\mathbf{X}}_2) \\ &= H(\check{C}_1^{m_1} \check{C}_2^{m_2}) - H(\check{C}_1^{m_1} \check{C}_2^{m_2} | \check{\mathbf{X}}_1 \check{\mathbf{X}}_2) \\ &\stackrel{(a)}{=} m_1 \log |\mathcal{X}_1| + m_2 \log |\mathcal{X}_2| - H(\check{C}_1^{m_1} \check{C}_2^{m_2} | \check{\mathbf{X}}_1 \check{\mathbf{X}}_2) \\ &= m_1 \log |\mathcal{X}_1| + m_2 \log |\mathcal{X}_2| \\ &\quad - H(\Phi_1^{(n)}(\mathbf{K}_1, \check{\mathbf{X}}_1) \Phi_2^{(n)}(\mathbf{K}_2, \check{\mathbf{X}}_2) | \check{\mathbf{X}}_1 \check{\mathbf{X}}_2) \\ &\stackrel{(b)}{\geq} m_1 \log |\mathcal{X}_1| + m_2 \log |\mathcal{X}_2| - H(\mathbf{K}_1 \mathbf{K}_2 | \check{\mathbf{X}}_1 \check{\mathbf{X}}_2) \\ &= m_1 \log |\mathcal{X}_1| + m_2 \log |\mathcal{X}_2| - nH(\mathbf{K}_1 \mathbf{K}_2). \end{aligned}$$

Step (a) follows from Lemma 1 part c). Step (b) follows from the data processing inequality. Furthermore for $i = 1, 2$, we have the following chain of inequalities:

$$\begin{aligned} \Delta_{\text{max-MI}}^{(n)} &\geq I(\check{C}_1^{m_1} \check{C}_2^{m_2}; \check{\mathbf{X}}_1 \check{\mathbf{X}}_2) \geq I(\check{C}_i^{m_i}; \check{\mathbf{X}}_i) \\ &= H(\check{C}_i^{m_i}) - H(\check{C}_i^{m_i} | \check{\mathbf{X}}_i) \stackrel{(a)}{=} m_i \log |\mathcal{X}_i| - H(\check{C}_i^{m_i} | \check{\mathbf{X}}_i) \\ &= m_i \log |\mathcal{X}_i| - H(\Phi_i^{(n)}(\mathbf{K}_i, \check{\mathbf{X}}_i) | \check{\mathbf{X}}_i) \\ &\stackrel{(b)}{\geq} m_i \log |\mathcal{X}_i| - H(\mathbf{K}_i | \check{\mathbf{X}}_i) = m_i \log |\mathcal{X}_i| - nH(\mathbf{K}_i). \end{aligned}$$

Step (a) follows from Lemma 1 part c). Step (b) follows from the data processing inequality. \blacksquare

REFERENCES

- [1] B. Santoso and Y. Oohama, "Privacy amplification of distributed encrypted sources with correlated keys," in *2017 IEEE International Symposium on Information Theory - ISIT*. IEEE, 2017, pp. 958–962.
- [2] —, "Secrecy amplification of distributed encrypted sources with correlated keys using post-encryption-compression," *IEEE Trans. Information Forensics and Security*, vol. 14, no. 11, pp. 3042–3056, November 2019.
- [3] M. Johnson, P. Ishwar, V. Prabhakaran, D. Schonberg, and K. Ramchandran, "On compressing encrypted data," *IEEE Transactions on Signal Processing*, vol. 52, no. 10, pp. 2992–3006, Oct 2004.
- [4] D. Kline, C. Hazay, A. Jagmohan, H. Krawczyk, and T. Rabin, "On compression of data encrypted with block ciphers," *IEEE Trans. Information Theory*, vol. 58, no. 11, pp. 6989–7001, 2012. [Online]. Available: <https://doi.org/10.1109/TIT.2012.2210752>
- [5] C. E. Shannon, "A mathematical theory of communication," *Bell System Technical Journal*, vol. 27, pp. 379–423, 623–656, July, October 1948.
- [6] H. Yamamoto, "Information theory in cryptography," *IEICE Transactions*, vol. E.74, no. 9, pp. 2456–2464, September 1991.

- [7] M. Iwamoto, K. Ohta, and J. Shikata, "Security formalizations and their relationships for encryption and key agreement in information-theoretic cryptography," *IEEE Trans. Inf. Theory*, vol. 64, no. 1, pp. 654–685, 2018. [Online]. Available: <https://doi.org/10.1109/TIT.2017.2744650>
- [8] M. Iwamoto, "Security notions for information theoretically secure encryptions," in *Proc. IEEE Int. Symp. Inf. Theory 2011*, Saint-Petersburg, Russia, 2011, pp. 1777–1781.
- [9] Y. Oohama and T. S. Han, "Universal coding for the Slepian-Wolf data compression system and the strong converse theorem," *IEEE Trans. Inform. Theory*, vol. 40, no. 6, pp. 1908–1919, November 1994.