

# TRIPLE M: A PRACTICAL NEURAL TEXT-TO-SPEECH SYSTEM WITH MULTI-GUIDANCE ATTENTION AND MULTI-BAND MULTI-TIME LPCNET

*Shilun Lin, Xinhui Li, Li Lu*

Tencent Inc, China  
{cirolin, hiccupli, adolphu}@tencent.com

## ABSTRACT

Although the sequence-to-sequence network with attention mechanism and neural vocoder has made great progress in the quality of speech synthesis, there are still some problems to be solved in large-scale real-time applications. For example, to avoid long sentence alignment failure while maintaining rich prosody, and to reduce the computational overhead while ensuring perceptual quality. In order to address these issues, we propose a practical neural text-to-speech system, named Triple M, consisting of a seq2seq model with multi-guidance attention and a multi-band multi-time LPCNet. The former uses alignment results of different attention mechanisms to guide the learning of the basic attention mechanism, and only retains the basic attention mechanism during inference. This approach can improve the performance of the text-to-feature module by absorbing the advantages of all guidance attention methods without modifying the basic inference architecture. The latter reduces the computational complexity of LPCNet through combining multi-band and multi-time strategies. The multi-band strategy enables the LPCNet to generate sub-band signals in each inference. By predicting the sub-band signals of adjacent time in one forward operation, the multi-time strategy further decreases the number of inferences required. Due to the multi-band and multi-time strategy, the vocoder speed is increased by 2.75x on a single CPU and the MOS (mean opinion score) degradation is slight.

**Index Terms**— Speech synthesis, attention, sequence-to-sequence models, vocoder, LPCNet

## 1. INTRODUCTION

Generating natural audio sample from text in real time is an important technology with many application scenarios, such as audiobook broadcast, virtual assistant, etc. In the past few years, speech synthesis becomes one of the most extensively researched fields. The concatenative speech synthesis system divides pre-recorded audio into small units. During synthesis, these small phonics units are connected in series through dynamic algorithms (e.g., Viterbi algorithm) [1, 2]. Statistical parametric speech synthesis (SPSS) uses the hidden Markov models (HMMs) [3] or the deep neural networks (DNNs) [4] to generate speech features to be synthesized by source-filter vocoders [5]. These systems achieve real-time synthesis and solve issues that concatenative systems have. However, the

synthesized audio sample is unnatural compared to human speech because of the introduction of source-filter vocoders and the over-smoothing of acoustic models.

To tackle these problems, WaveNet, an autoregressive generative model of time-domain samples has been proposed [6]. WaveNet produces high quality audio utilizing structured linguistic features, phoneme durations and log fundamental frequencies as conditions. Furthermore, the idea of modeling raw waveform directly leads to a new generation of neural vocoders, which can synthesize speech from acoustic features and surpass traditional source-filter vocoders in SPSS. The flow based neural vocoders, such as Parallel WaveNet [7] and Clarinet [8], reduce the computational overhead of WaveNet by learning from the teacher WaveNet and realize real-time synthesis on the GPU. Recently, autoregressive models with simple structures like WaveRNN [9] and LPCNet [10] have been proposed for real-time synthesis on CPU by introducing sparse GRU.

At the same time, text-to-feature modules for converting text into acoustic features that can be fed to neural vocoders are also evolving. Sequence-to-sequence neural network [11] with attention mechanism is one of the most popular methods. Tacotron [12, 13] produces acoustic features (e.g., magnitude spectrograms, Mel spectrograms) from a character sequence. The traditional synthesis process is simplified by merging the generation of linguistic features and acoustic features into a single network, and training end-to-end with the massive data. Attention mechanism is applied to align the input and output sequences. Therefore, the training is no longer fragmented. Content-based attention [14], which is applied in the original Tacotron [12], does not fully consider the monotonicity and locality between the text and the acoustic features. Tacotron2 introduces the location related information into content-based attention to reduce the risk of long sentence alignment failure. Because there are still some problems in this hybrid attention mechanism (for instance, no explicit monotonicity restriction and weak generalization of long sentence synthesis), more attention mechanisms have been put forward and employed in natural speech synthesis. These methods can be roughly divided into two categories, monotonic attention mechanism [15, 16, 17] and location-relative attention mechanism [18, 19]. These mechanisms have been proved to be effective in improving the speed of convergence, the stability of feature generation and the robustness of long sentence synthesis.

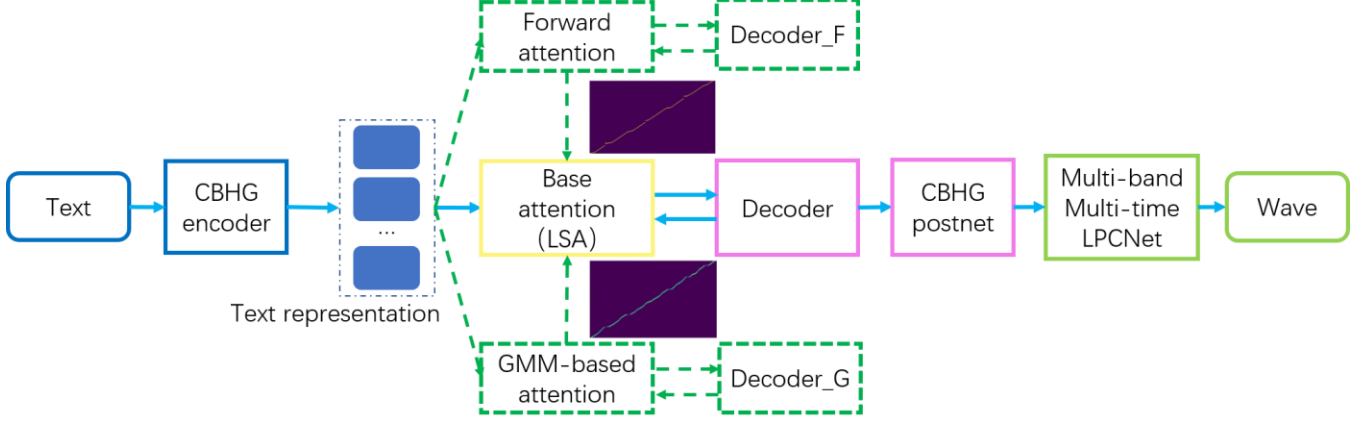

Fig 1. System architecture of our proposed Triple M.

## 2. PROPOSED METHOD

In this paper, we come up with a multi-guidance attention mechanism, which enables the basic attention mechanism to learn different strengths from multiple guidance sources. In this way, new attention properties can be integrated without modifying the inference framework of the online system. The sequence-to-sequence model with multi-guidance attention, together with the multi-band multi-time LPCNet, constitute a practical neural text-to-speech system named Triple M. The architecture of Triple M is shown in Figure 1. Audio samples are available at [Triple M audio samples](#).

### 2.1. Multi-guidance attention

The proposed text-to-feature module with the multi-guidance attention, as depicted in Figure 1, uses the improved hybrid location sensitive attention proposed in Tacotron2 [13] as the basic attention. We use CBHG encoder to transform Chinese Pinyin sequences with tone and prosody information  $\{x_i\}_{i=1}^L$  into hidden text representations  $\{h_i\}_{i=1}^L$  that are more suitable for attention mechanism (1). An attention RNN uses the last state, context vector and decoding result of the previous time step as input, and outputs the current state  $s_t$  for computing the attention score (2). The hybrid location-sensitive attention module takes the current state, hidden representations and location-related information as input to get the attention score  $\alpha_t$  (3). And then the context vector  $c_t$  at the current moment is calculated (4). Finally, current attention RNN state and the context vector are input to the decoder RNN. Then the current state of the decoder  $d_t$  (5) is obtained and passed through an affine function to obtain the final decoding result  $o_t$  (6).

$$\{h_i\}_{i=1}^L = \text{CBHGEncoder}(\{x_i\}_{i=1}^L) \quad (1)$$

$$s_t = \text{AttentionRNN}(s_{t-1}, c_{t-1}, o_{t-1}) \quad (2)$$

$$\alpha_t = \text{LSAttention}(s_t, h_i, l_t) \quad (3)$$

$$c_t = \sum_i \alpha_{t,i} h_i \quad (4)$$

$$d_t = \text{DecoderRNN}(d_{t-1}, c_t, s_t) \quad (5)$$

$$o_t = \text{Affine}(d_t) \quad (6)$$

The multi-guidance attention mechanism is introduced into the above basic structure. All guidance attention modules share the encoder with the basic attention module, and each has its own attention RNN and decoder RNN (the structure is the same). Two attention mechanisms with different original intentions, forward attention [15] and GMM-based attention [18], are selected to provide guidance attention score  $af_t$  and  $ag_t$ . As a kind of monotonic attention mechanism, forward attention only considers the alignment paths that satisfy the monotonic condition at each decoding time step to ensure the monotonicity of the final alignment path. This method has been verified to accelerate the convergence and improve the stability of feature generation. However, it is observed that the training process often fails to learn any valid alignments. And adding a fixed diagonal mask to constrain the attention alignment matrix in training is helpful to fix this problem [17]. Referring to the connectionist temporary classification model (CTC), an intermediate variable  $e_{t,i}$  is defined to represent the probability sum of all monotonic alignment paths.  $e_{t,i}$  can be calculated recursively (here  $\alpha_{t,i}$  can be the attention score of position  $i$  at decode step  $t$  generated by the basic attention module). Then  $af_{t,i}$  can be obtained by normalization (7, 8).

$$e_{t,i} = (e_{t-1,i} + e_{t-1,i-1}) \alpha_{t,i} \quad (7)$$

$$af_{t,i} = \frac{e_{t,i}}{\sum_i e_{t,i}} \quad (8)$$

Different from forward attention, GMM-based attention is a purely location-related attention mechanism. It can bring benefits to the basic attention mechanism that are different from those of the monotonic attention mechanism, such as the robustness to long sentence synthesis (much longer than those seen during training) while preserving naturalness on shorter

utterances. GMM-based attention uses a N Gaussians mixture distribution to produce attention score  $ag_{t,i}$  (13). Given the current attention RNN state  $s_t$ , three intermediate parameters  $\omega'_t, \mu'_t, \sigma'_t$  are initially calculated by a multi-layer perceptron (MLP) (9). Then three intermediate parameters are refined by varied transfer functions to get the parameters of the gaussian mixture distribution. There is no systematic scheme for the selection of transfer functions. Empirically, mixture weights are normalized by the soft-max. Variance is calculated by the exponential function, and mean shift is got by the soft-plus to ensure that it is positive (10, 11, 12).

$$\omega'_t, \mu'_t, \sigma'_t = MLP(s_t) \quad (9)$$

$$\omega_t = softmax(\omega'_t) \quad (10)$$

$$\sigma_t = exp(\sigma'_t) \quad (11)$$

$$\mu_t = softplus(\mu'_t) + \mu_{t-1} \quad (12)$$

$$ag_{t,i} = \sum_n \omega_{t,n} exp(-\frac{(\mu_{t,n} - i)^2}{2\sigma_{t,n}}) \quad (13)$$

During training, the guidance components are trained together with the basic structure. Only the basic module is retained in inference. The training loss function consists of three parts. The first one is the distance between the decoder output and the real acoustic feature. Then there is the distance between the output of post-processing network and the real acoustic feature. The last part includes distances between the basic alignment score and all guidance alignment scores. The distance metric is worthy of further discussion. For brevity, we uniformly adopt the L1 norm as the distance metric.

## 2.2. Multi-band multi-time LPCNet

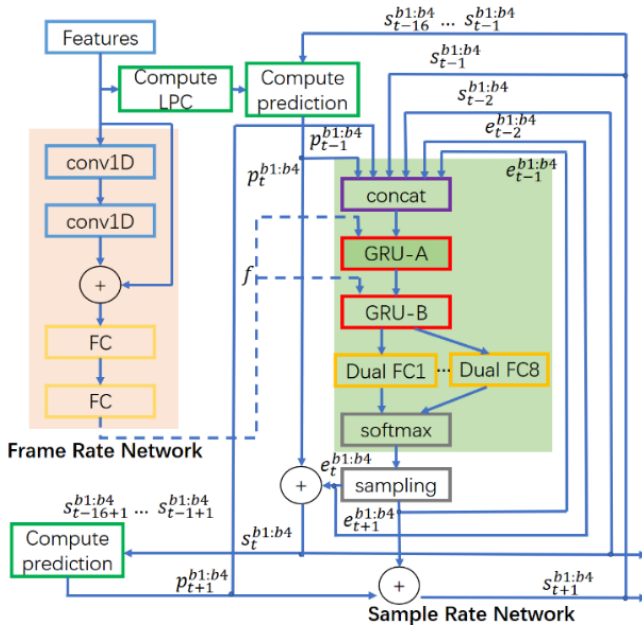

Fig 2. The flowchart of multi-band multi-time LPCNet.

As a relatively lightweight neural vocoder, the key idea of LPCNet [10] is to model the vocal tract response through a low-cost linear prediction filter and use a smaller network to obtain the excitation. However, for large-scale applications, the computational overhead of the LPCNet still has room for improvement. The original LPCNet is composed of the frame rare network (FRN) and the sample rate network (SRN). The former extracts high-level representations from conditional acoustic features. The latter including two GRU layers and a dual FC layer needs to loop N times per frame to obtain N sampling points corresponding to this frame. Therefore, the SRN occupies a major part of the overall calculation.

Inspired by multi-band vocoders [20, 21, 22] and sample bundling [23], we propose a multi-band multi-time strategy to make full use of every forward of SRN. As shown in Figure 2, in each forward, except for the dual FC layer, the rest of the SRN layers are shared. SRN runs in autoregressive mode. The excitations, audio samples from the previous round and obtained predictions (at the last and the current time) are used as the input of the first GRU layer (GRU-A). The output of the second GRU layer (GRU-B) is sent to 8 independent dual FC layers to predict the excitation of sub-bands at adjacent time. After that, the audio samples at the current adjacent time can be acquired recursively. At the same time, the LPC queue is updated to prepare for the next LPC prediction. Although 7 more dual FC layers are introduced and the input matrix of GRU-A layer will become larger (the table lookup operation makes this overhead negligible), the multi-band multi-time strategy reduces the number of cycles required for SRN by 8 times. Therefore, the speed of the vocoder is increased by 2.75x without other calculation optimization.

## 3. EXPERIMENTS

### 3.1. Experimental setup

The experiments used a Mandarin corpus recorded by a Chinese male speaker. All recordings were sampled at 16kHz with 16-bit quantization. About 16 hours of recordings (with an average length of 90 characters) were used for training. 100 regular and 100 long utterances (with an average length of 1000 characters) were tested. Consistent with the original LPCNet, 18 Bark cepstral coefficients and 2 pitch parameters were extracted as conditions of the vocoder. At the same time, they were also used as the prediction targets of the text-to-feature module.

The text-to-feature module was a Tacotron-like structure, with a CHBG module at the beginning and the end as encoder and post-net respectively. The main component of decoder was a two-layer 512-dimensional unidirectional LSTM. All attention modules were composed of a unidirectional GRU layer and a corresponding attention mechanism. All modules were trained together at the beginning. After the guidance attention mechanisms became reliable, the basic attention mechanism began to learn from them. Forward attention gave the basic attention an explicit monotonic constraint to make

the learning process more stable. And GMM-based attention provided more location-related details to the basic attention. Consequently, it acquired the ability to synthesize sentences far longer than the utterances in the training set.

In the original LPCNet, SRN consisted of a 90% sparse 384-dimensional GRU layer, a normal 16-dimensional GRU layer and a 256-dimensional dual FC layer. As to the multi-band multi-time LPCNet, dimensions of all GRU layers kept unchanged. The hyper-parameters of sub-band and time span included in the inference were set to 4 and 2 respectively in order to reach a reasonable compromise between the quality and the computational cost.

### 3.2. Evaluations

The experiment found that learning from forward attention and GMM-based attention, the basic attention formed a clear alignment at the second epoch. It took much less epochs than 10 epochs required without guidance signals. This prevented the model falling into bad alignment in early stage of training and provided a stable basis for the subsequent training. Under the constraint of the forward attention, basic attention learned long sentence synthesis from the GMM-based attention and retained prosodic information. From another view, the well-learned basic attention played the role of the fixed diagonal mask, which gave a constraint to the forward attention matrix [17]. Figure 3 shows the alignment formed when the model synthesized a long sentence including 200 Chinese words (the number of characters finally input to the encoder was 1644). As we can see from this figure, the alignment was shape and strong. The baseline model (without multi-guidance attention) failed to deal with such long sentence. In the long sentence synthesis experiment (the average length was 1000 characters, which was 10 times longer than the training sentences), the failure rates were 40% and 15% when GMM-based attention and forward attention were severally used as guidance signals, while the failure rate of baseline model was more than 60%. Applying these two attention mechanisms simultaneously to guide the learning of the basic attention reduced the failure rate to 2%. At the same time, the prosodic consistency of long sentences is well maintained.

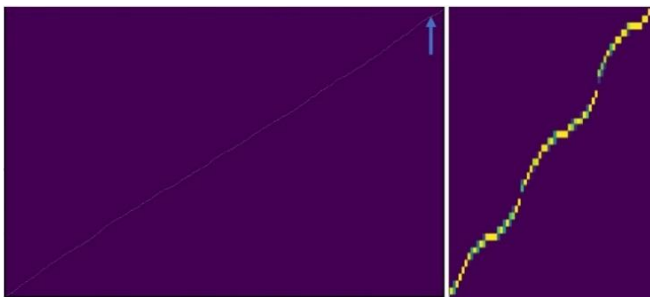

**Fig 3.** Alignment of a long utterance given by the multi-guidance text-to-feature module. On the right is the zoom in version at the end of the sentence.

In order to verify the influence of the multi-guidance attention mechanism on perceptual quality, a mean opinion score (MOS) listening test was implemented. Native Chinese speakers were invited to listen and score 100 sentences. Table 1 summarized the results of the MOS test. Overall, in addition to enhancing the ability to generate long samples, the multi-guidance attention slightly improved the perceptual quality.

**Table 1.** MOS score with 95% confidence intervals.

Model	MOS
Baseline	4.52±0.08
<b>Multi-guidance</b>	<b>4.57±0.05</b>
Ground True	4.65±0.04

According to the calculation method (14) mentioned in [4], the total complexity of the SRN was around 2.8 GFLOPS ( $G_A = 384, G_B = 16, d = 0.1, Q = 256, N_B = 1, N_T = 1$ ).

The introduction of the multi-band multi-time strategy reduced the complexity of the SRN to around 1.0 GFLOPS ( $G_A = 384, G_B = 16, d = 0.1, Q = 256, N_B = 4, N_T = 2$ ). Since the calculation of LPCNet was mainly concentrated in the two GRU layers and the dual FC layer, this strategy can significantly improve the speed of the vocoder.

$$C = \frac{(3dG_A^2 + 3G_B(G_A + G_B) + 2G_BQ \cdot N_B N_T) \cdot 2F_S}{N_B N_T} \quad (14)$$

To demonstrate that the multi-band multi-time strategy can accelerate synthesis without significantly degrading the perceptual quality, the comparison experiment of MOS and real-time factor was implemented. The experimental results were presented in Table 2. The results showed that the multi-band and multi-time strategy brought a 2.75x improvement in speed while the MOS has only dropped by 3%.

**Table 2.** MOS score with 95% confidence intervals and real time factor of vocoders.

Model	MOS	RTF
LPCNet	4.57±0.05	0.303
<b>Multi-band &amp; multi-time</b>	<b>4.45±0.07</b>	<b>0.110</b>

## 4. CONCLUSION

In this paper, we have proposed triple M, a practical text-to-speech system composed of a text-to-feature module trained under the multiple supervision and a multi-band multi-time LPCNet. This system integrated the advantages of various attention mechanisms (such as stable feature generation and robust long sentence synthesis) and exploited the acceleration potential of the LPCNet (2.75x speedup without significantly reducing synthesis quality). In the future, the architecture can easily incorporate more outstanding attention mechanisms without changing the basic forward logic. In addition, how to better fuse the time and frequency domain information into LPCNet is also worth discussing.

## 5. REFERENCES

- [1] Hunt, Andrew J., and Alan W. Black. "Unit selection in a concatenative speech synthesis system using a large speech database." In 1996 IEEE International Conference on Acoustics, Speech, and Signal Processing Conference Proceedings, vol. 1, pp. 373-376. IEEE, 1996.
- [2] A. W. Black and P. Taylor. "Automatically clustering similar units for unit selection in speech synthesis." In Proc. Eurospeech, pp. 601-604. 1997.
- [3] Tokuda, Keiichi, Takayoshi Yoshimura, Takashi Masuko, Takao Kobayashi, and Tadashi Kitamura. "Speech parameter generation algorithms for HMM-based speech synthesis." In 2000 IEEE International Conference on Acoustics, Speech, and Signal Processing. Proceedings, vol. 3, pp. 1315-1318. IEEE, 2000.
- [4] Ze, Heiga, Andrew Senior, and Mike Schuster. "Statistical parametric speech synthesis using deep neural networks." In 2013 IEEE International Conference on Acoustics, Speech and Signal Processing, pp. 7962-7966. IEEE, 2013.
- [5] Kawahara, Hideki, Ikuyo Masuda-Katsuse, and Alain De Cheveigne. "Restructuring speech representations using a pitch-adaptive time-frequency smoothing and an instantaneous-frequency-based F0 extraction: Possible role of a repetitive structure in sounds." *Speech communication* 27, no. 3-4 (1999): 187-207.
- [6] Oord, Aaron van den, Sander Dieleman, Heiga Zen, Karen Simonyan, Oriol Vinyals, Alex Graves, Nal Kalchbrenner, Andrew Senior, and Koray Kavukcuoglu. "Wavenet: A generative model for raw audio." arXiv preprint arXiv:1609.03499 (2016).
- [7] Oord, Aaron, Yazhe Li, Igor Babuschkin, Karen Simonyan, Oriol Vinyals, Koray Kavukcuoglu, George Driessche et al. "Parallel wavenet: Fast high-fidelity speech synthesis." In International conference on machine learning, pp. 3918-3926. PMLR, 2018.
- [8] Ping, Wei, Kainan Peng, and Jitong Chen. "Clarinet: Parallel wave generation in end-to-end text-to-speech." arXiv preprint arXiv:1807.07281 (2018).
- [9] Kalchbrenner, Nal, Erich Elsen, Karen Simonyan, Seb Noury, Norman Casagrande, Edward Lockhart, Florian Stimberg, Aaron van den Oord, Sander Dieleman, and Koray Kavukcuoglu. "Efficient neural audio synthesis." arXiv preprint arXiv:1802.08435 (2018).
- [10] Valin, Jean-Marc, and Jan Skoglund. "LPCNet: Improving neural speech synthesis through linear prediction." In ICASSP 2019-2019 IEEE International Conference on Acoustics, Speech and Signal Processing (ICASSP), pp. 5891-5895. IEEE, 2019.
- [11] Sutskever, Ilya, Oriol Vinyals, and Quoc V. Le. "Sequence to sequence learning with neural networks." In *Advances in neural information processing systems*, pp. 3104-3112. 2014.
- [12] Wang, Yuxuan, R. J. Skerry-Ryan, Daisy Stanton, Yonghui Wu, Ron J. Weiss, Navdeep Jaitly, Zongheng Yang et al. "Tacotron: Towards end-to-end speech synthesis." arXiv preprint arXiv:1703.10135 (2017).
- [13] Shen, Jonathan, Ruoming Pang, Ron J. Weiss, Mike Schuster, Navdeep Jaitly, Zongheng Yang, Zhifeng Chen et al. "Natural tts synthesis by conditioning wavenet on mel spectrogram predictions." In 2018 IEEE International Conference on Acoustics, Speech and Signal Processing (ICASSP), pp. 4779-4783. IEEE, 2018.
- [14] Bahdanau, Dzmitry, Kyunghyun Cho, and Yoshua Bengio. "Neural machine translation by jointly learning to align and translate." arXiv preprint arXiv:1409.0473 (2014).
- [15] Zhang, Jing-Xuan, Zhen-Hua Ling, and Li-Rong Dai. "Forward attention in sequence-to-sequence acoustic modeling for speech synthesis." In 2018 IEEE International Conference on Acoustics, Speech and Signal Processing (ICASSP), pp. 4789-4793. IEEE, 2018.
- [16] He, Mutian, Yan Deng, and Lei He. "Robust sequence-to-sequence acoustic modeling with stepwise monotonic attention for neural TTS." arXiv preprint arXiv:1906.00672 (2019).
- [17] Lim, Dan, Won Jang, Hyeeyeong Park, Bongwan Kim, and Jesam Yoon. "JDI-T: Jointly trained Duration Informed Transformer for Text-To-Speech without Explicit Alignment." arXiv preprint arXiv:2005.07799 (2020).
- [18] Graves, Alex. "Generating sequences with recurrent neural networks." arXiv preprint arXiv:1308.0850 (2013).
- [19] Battenberg, Eric, R. J. Skerry-Ryan, Soroosh Mariooryad, Daisy Stanton, David Kao, Matt Shannon, and Tom Bagby. "Location-relative attention mechanisms for robust long-form speech synthesis." In ICASSP 2020-2020 IEEE International Conference on Acoustics, Speech and Signal Processing (ICASSP), pp. 6194-6198. IEEE, 2020.
- [20] Okamoto, Takuma, Tomoki Toda, Yoshinori Shiga, and Hisashi Kawai. "Improving FFTNet vocoder with noise shaping and subband approaches." In 2018 IEEE Spoken Language Technology Workshop (SLT), pp. 304-311. IEEE, 2018.
- [21] Okamoto, Takuma, Kentaro Tachibana, Tomoki Toda, Yoshinori Shiga, and Hisashi Kawai. "An investigation of subband WaveNet vocoder covering entire audible frequency range with limited acoustic features." In 2018 IEEE International Conference on Acoustics, Speech and Signal Processing (ICASSP), pp. 5654-5658. IEEE, 2018.
- [22] Yu, Chengzhu, Heng Lu, Na Hu, Meng Yu, Chao Weng, Kun Xu, Peng Liu et al. "Durian: Duration informed attention network for multimodal synthesis." arXiv preprint arXiv:1909.01700 (2019).
- [23] Vippera, Ravichander, Sangjun Park, Kihyun Choo, Samin Ishtiaq, Kyoungbo Min, Sourav Bhattacharya, Abhinav Mehrotra, Alberto Gil CP Ramos, and Nicholas D. Lane. "Bunched LPCNet: Vocoder for Low-cost Neural Text-To-Speech Systems." arXiv preprint arXiv:2008.04574 (2020).