

# BE-RAN: Blockchain-enabled Open RAN with Decentralized Identity Management and Privacy-Preserving Communication

Hao Xu, Lei Zhang, *Senior Member, IEEE*, Elaine Sun, and Chih-Lin I, *Fellow, IEEE*

**Abstract**—Radio Access Networks (RAN) tends to be more distributed in the 5G new radio in order to provide low latency and flexible on-demanding services. In this paper, Blockchain-enabled Radio Access Networks (BE-RAN) is proposed as a novel decentralized RAN architecture to facilitate enhanced security and privacy on identification and authentication. It can offer user-centric identity management for User Equipment (UE) and Radio Access Networks (RAN) elements and mutual authentication to all entities while enabling on-demand point-to-point communication with accountable billing service add-on to the general public. Also, a potential operating model with thorough decentralization of RAN is envisioned. The distributed privacy-preserving P2P communication, as one of the core use cases for future mobile networks, is presented as an essential complement to the existing core network-based security and privacy management. The results show that BE-RAN significantly improves communication and computation overheads compared to the existing communication authentication protocols.

**Index Terms**—RAN, DLT, Blockchain, authentication, identity management, blockchain-native infrastructure, privacy-preserving, Open RAN, O-RAN

## I. INTRODUCTION

THE centralized architecture is one of the bases of state-of-the-art cellular mobile networks that are typically composed of Radio Access Networks (RAN) and Core Networks (CN) [1]. However, with recently booming demands of distributed scenarios [2][3], for instance, industrial IoT (IIoT), autonomous driving, industry 4.0, etc., such a centralized architecture is facing challenges in terms of communication latency and data privacy issues since sensitive data have to go through the centralized CN that is typically remote to users. In order to address these issues, a new market-driven practice of private 5G is welcomed by many industries with modification of network topology and introduction of Edge Networks, to bring down the essential functions like authentications and identity management from remote CN to the local edge [4]. As such, we have seen many industrial applications utilize the private CN and Mobile Edge Computing (MEC) to provide bespoke on-premise service for better latency, data privacy, and communication security [4].

H. Xu and L. Zhang are with James Watt School of Engineering, University of Glasgow, G12 8QQ, UK, e-mail: {Hao.Xu, Lei.Zhang}@glasgow.ac.uk

Elaine Sun is going to be with Northwestern University, Evanston, IL 60208.

C. L. I is the Chief Scientist of wireless technologies at China Mobile Research Institute, Beijing, China, e-mail: icl@chinamobile.com

Manuscript is subject to submission to IEEE journals for potential publication. Corresponding authors: Lei Zhang and Chih-Lin I

Indeed, the CN has been partially realized and replaced by industrial users with the edge network and private User Plane Function (UPF) [5]. However, it is still a relatively heavy-cost solution, as the need for standalone hardware is not avoidable. Additionally, with all the benefits of having the core at the edge, it raises privacy concerns for the public users while their data are processed with lower integrity and confidentiality assurance. In the case of privacy leakages, it brings threats of identity attacks, targeted phishing information, and other unlawful exploitation of users' privacy.

From the RAN perspective, it is experiencing the architectural transition from LTE towards 5G New Radio (5G NR) and Open RAN/O-RAN initiatives [4], marking the transition from physically distributed basestations to centrally managed and loosely coupled basestation control functions, for instance, Centralized Units (CU), Distributed Units (DU) and Radio Units (RU). A good example is C-RAN with C standing for Cloud, Centralized features for software-defined RAN evolution [6][7]; and O-RAN, an open initiative pursued by operators and vendors. Thanks to initiatives of centralizing CU and DU into server clusters, the universal computing capacity offers more significant possibilities to manage and optimize the network. For instance, additional RAN functions can be integrated into the existing system simply by adding a virtual machine or container instance [1].

Thus, the trend of RAN is determined to become an open and flexible network system of radio resources management in the near future. In particular, the functional split of RAN at the lower layer brings tons of new enabling innovations [8][9] with potential improvements, such as enabling distributed features to aid the decoupled RAN architecture for better privacy to all. Thanks to this trend, the adoption of distributed ledger in RAN is potentially to be a part of the promising implementation of blockchain-native infrastructure initiative [10][11][12] with unique decentralized authentication protocols powered by global synchronized identities record. By considering blockchain-enabled identity management and authentication functions within the RAN scope, there is an opportunity to lower the cost and aid the CN to provide more secured and user-centric service [6] in the era of loosely couple RAN elements deployment.

### A. Motivation

The most beneficial feature enabled by enriching RAN functions distribution and decentralization is the privacy-preserving Point-to-Point (P2P) communication, which is a

type of communication between two individuals without being interpreted by third-party service. P2P communication is an instance of ways doing End-to-End (E2E), Device-to-Device (D2D), and other types of communications, where the direct link between participants are required. Note that the direct link is not inclusively physical but a logical link through simple routing and switching. It is also the key to ensure privacy and security among users. Such P2P communication appeals to industrial users who value the latency and privacy on their on-premise network. As opposed to a centralized server-client model, the distributed P2P model requires the sender to know the global route-able user address/identifier of the recipient, such as the IP address usage in peer-to-peer file sharing, e.g., Torrent.

However, the independent P2P communication sees limitations on lacking global peer discovery and routing with courtesy to communication privacy and security, without third-party help, and the coverage becomes the bottleneck and leaves the vulnerability to users. Another issue faced by the existing mobile network is that the UE under a cellular network is restrained from direct communicating to other users of the same RAN cell. Because of the centralized architecture of the cellular network [9], e.g., 2G/3G/4G and 5G networks, it means the user who intends to contact another local user of the same Mobile Networks Operator (MNO) (The proposed scheme in this paper, detailed later, is also expandable to local cross MNOs operations) under the same basestation, cannot be connected without the involvement of CN. The primary restrictions are that the user identity authentication, routing, and paging capability are only available at CN, for example, as seen in Fig. 1, where the 3GPP authentication goes through CN. As a case in point, two subscribers of EE, a UK-based MNO, want to call each other in the same house covered by the same basestation, the message needs to be processed by EE's CN to connect both users, even though they are sitting close to each other. Having said that, one UE cannot page other UE directly just because of no access to its physical address used by RAN, neither the record of UE physical address records at RAN side. Therefore, a distributed user-centric identity management to achieve RAN side P2P UE discovery is the key to enable various low latency and low-cost application scenarios.

Distributed Ledger Technology or Blockchain, is an ideal medium for participating users to be synced, offers immutable and persistent distributed records for all participants' identities, using state-of-the-art encryption provides users with demanded identity management and authentication. With the help of emerging blockchain technology, global distributed identity issues can be addressed by the decentralization nature of blockchain. By making identity management and mutually authenticated communication locally at RAN side with synchronized global identities' record, a UE can reach out another UE within the same RAN coverage without accessing CN, for better privacy and latency performance, as shown in the overview of the proposed BE-RAN system in Fig. 1, where the non-3GPP AP and D2D UEs are sourced and managed by local user groups and removes the need for remote network to local-only use cases.

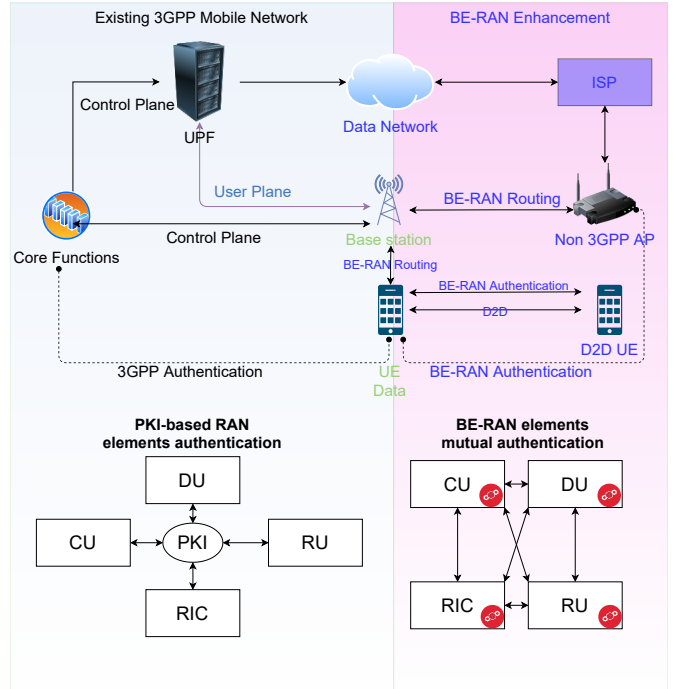

Fig. 1. Overview of BE-RAN in addition to existing mobile network

As distributed communication demands rise from both industrial and consumer applications, the RAN needs to evolve with a decentralization focus and provide security support to users of distributed scenarios for better privacy and connectivity. To redeem the benefits mentioned above of distributed identity management and mutual authentication powered by blockchain, we propose blockchain-enabled identity management and mutual authentication as core functions of BE-RAN.

## B. Contributions and Organizations

In this paper, an overall architecture of BE-RAN is presented. By introducing blockchain into RAN, we have contributed a revolutionary methodology for RAN operation with the following detailed contributions.

- A novel security framework is proposed to couple much-needed distributed application of RAN, and facilitates D2D and other decentralized communications.
- A novel blockchain-enabled mutual authentication architecture for BE-RAN and beyond is a combination of zero-trust identity management and zero-trust mutual authentication without third-party Certificate Authority (CA) or any other Public Key Infrastructure (PKI). It enables users to set up privacy-preserving end-to-end encrypted communication channels and enables decentralized secured privacy-preserving billing service for RAN users and access control based on blockchain token/account balance.
- A design guideline for BE-RAN routing, switching, and Quality of Service (QoS) management, along with a potential operation model for operators to consider resource sharing via blockchain.

By taking the full potential enabled by distributed features of BE-RAN, it can play an important role for distributed and decentralized communication scenarios, such as D2D, IIoT, autonomous driving, etc., without adding more burden to limited fiber resources used by RAN-CN connection and improves E2E latency and privacy. Meanwhile, it aims to provide user-centric identity management and authentication solution for the whole network and enables on-demand point-to-point communication with accountable billing service to the public without altering network infrastructure. Besides the everyday service to users, enhanced decentralization of RAN makes tremendous impacts on emergency communication, where the disconnections of CN and upper level RAN elements are common.

In the rest of the paper, key concepts and preliminaries are detailed in Section II, and the BE-RAN framework with deployment architecture is introduced in Section III. Having the BE-RAN architecture explained, Section IV introduces the core mechanism of proclaimed security features and communications. With all essential technical content explained, Section V demonstrates a real-world application of BE-RAN with the context of RAN independent emergency service. Section VI provides insightful results of BE-RAN communication and computational overhead against other widely used practices in the communication industry. Section VII states the current challenges of making BE-RAN fully functional and the future steps to finalize BE-RAN. Finally, Section VIII concludes the paper with future works and opportunities.

## II. RELATED WORK

The following concepts and models are the intended RAN features and basis of blockchain concept used by BE-RAN, with the principle of CN functions, e.g., Access & Mobility Functions (AMF), Session Management Function (SMF), User Plane Function (UPF), Authentication Server Function (AUSF) and User Data Management (UDM) with Charging Function (CHF) of billing service, at RAN side in addition to existing functions by CN.

### A. RAN elements and UE identity

RAN consists of many components both physically and logically [1], and it relies on interconnecting interfaces to exchange control and user plane data both between RAN elements and CN. Under functional split defined by 3GPP [8], a common model of 5G RAN splits RAN network into logical units of CU at the network layer, DU at MAC layer, RU at PHY layer, and RAN controller, or potential adoption of state-of-the-art RAN Intelligent Controller (RIC) newly proposed by O-RAN alliance on upper layers of OSI reference model [13]. Hence, the interfaces require the management of RAN elements' identity to establish secured communication among them. RAN elements' actual identity is used to generate RAN element ID, which is to be used as a local or global identifier for inter-element communication at the control plane, e.g., X2, E2 interfaces. The interface-specific identifier is recognized and secured by public-key-based encryption and PKI with certificates, explained in Section VI, centrally managed by CA

[14]. Similar to the RAN element identity, UE identity is a logical identifier of UE known to RAN and CN in different senses, which correlates the UE with RAN service and policy. However, there are multiple identifiers of UE in the RAN network due to the fact that the identity may not reflect the individual but an individual or a collection of individuals in a particular time and service model.

In the cellular network, a UE never has accessibility to other UE's physical address but a mobile number/IP address, interpreted by the CN functions, for integrity and security purpose. Note that D2D defined by 3GPP makes use of CN functions for the control plane but leaves user plane data to the non-3GPP access network. It limits the P2P possibility because the UE does not know the other UE's physical interface address and cannot verify the identity without contacting CN. Since the UE identity is only revealed and verified by CN, for instance, at Unified Data Management(UDM) of 5G Core, routing and switching are only possible at higher-level cellular networks. Under the proposed framework of BE-RAN, it will be associated with a global blockchain address as a global identity for both UE, the user, which can be associated with any UE identity usage within the RAN and CN, serving as an index for all rout-able physical addresses, and any other things require direct interface address association.

### B. Blockchain and universal blockchain address

As introduced earlier, blockchain is a decentralized network organized by consensus agreed by all participants using a data type constructed by blocks of data linked by the previous block's hash [15]. Such datatype hardens the data integrity with immutable and tamper-proof records, which are ensured by the consensus of blockchain networks [16]. Each participating node in the blockchain network keeps a copy of the ledger, with a new block of records committed by the consensus winning nodes. Each participant of the network is either the miner (committing node) who keeps the ledger and offering essential network support of the blockchain network and the client who only requests transactions from the miner node. All committing nodes are miners with the duty of keeping the network alive.

During the committing process of blockchain operation, the consensus is the core activity for all participating miners, with designated mechanisms. There are two major general types of consensus mechanisms (CMs), proof-based and voting-based, resulting in different performance metrics [16]. A proof-based CM determines the ownership of the next mining opportunity by assessing the maximum proof-required items produced by every miner or miner group (in a statistical way), e.g., Proof of Work CM rewards the miner who has the largest computing power, and Proof of Stakes CM rewards the most prolonged and richest token holder. On the other hand, voting-based CMs are originated from fault tolerance mechanisms, where PBFT and RAFT are the most common types among them [16].

Blockchain address or wallet address is a self-generated string by hashing the public key of a key pair. The purpose of introducing blockchain address to the network and UE is to enable the interconnection of any individuals registered on the

ledger, thanks to the association of a global blockchain-backed identity with a physical rout-able address.

In the recent effort of integrating blockchain into RAN, B-RAN [17], and C-RAN with blockchain (BC-RAN) [18], showed a comprehensive understanding of the blockchain potential of RAN, where the value of trust-free and smart contracts are deeply acknowledged. However, the proposed BE-RAN did not assume trust on blockchain records neither execute smart contracts for BE-RAN core functions: identity management and mutual authentication. Instead, blockchain is taken as a medium of identity exchange, where the management is purely user-centric and zero-trust. BE-RAN conducts zero-trust mutual authentication over the unique blockchain-enabled routers, and switches functions with the identification exchanged over the blockchain. As all essential functions of BE-RAN are agnostic to trust and smart contract functions, the additional features can be integrated into BE-RAN to provide various transversal expansions.

### C. RAN security and Blockchain authentication

RAN elements have experienced the change from integrated basestations to 5G NR architecture [9], replacing the internal interfaces by interconnecting interfaces between all RAN elements. The interfaces require secure protocols to protect the RAN from outside attacks and ensure the connections are encrypted between every part of the RAN. The current state-of-the-art RAN opt-in PKI-based encryption and authentication solutions and transferring the trusted ground of elements into the zero-trust framework by O-RAN alliance [14].

Blockchain kicks in RAN security with its unique features of decentralized authentication protocols, as the conventional PKI solution requires a centralized or federated CA as a trusted party to provide identity notary. As the CA is a third-party service and possesses the credential and privacy of PKI users, it makes the CA a vulnerable target for malicious activities, and the communication outage with CA will result in catastrophic consequences for identity authentication and communication encryption.

To overcome the single point outage and privacy concerns, mutual authentication powered by the blockchain network mechanism is appealing to users and networks. By enabling blockchain in the network, the UE or element can quickly request authentication with the known blockchain address of other side users or elements and complete authentication by verifying both private keys' signature. Note that the cellular network security consists of UE security, RAN security, and CN security, and the scope of BE-RAN covers UE and RAN prospects, with potential security aid to CN security.

### D. Service billing

Service billing is the most basic incentive for operators to maintain the large-scale public communication network, and it is the core business of mobile network operators. In the traditional cellular network, service billing is processed in CN, counting the time of connection and data flow.

Blockchain is first introduced into reality in the name of Bitcoin as a ground-breaking cryptocurrency. As the genesis

of the first blockchain application is all about currency, the blockchain is an ideal platform to carry out billing service to users who only consume resources at RAN side with the same MNO or different MNOs.

## III. BLOCKCHAIN-ENABLED RAN

BE-RAN is a holistic approach to adapt the conventional RAN with decentralized focus enabled by novel identity management and mutual authentication, shown in Fig. 2, all its details are explained later in oncoming sections. It is designed from deconstructing functions via top-down approach, as BE-RAN frees the information which was only kept by CN at the top, but deployed with the construction of function by down-top approach, as the lower layers are all independently functional from upper-level elements in RAN and CN.

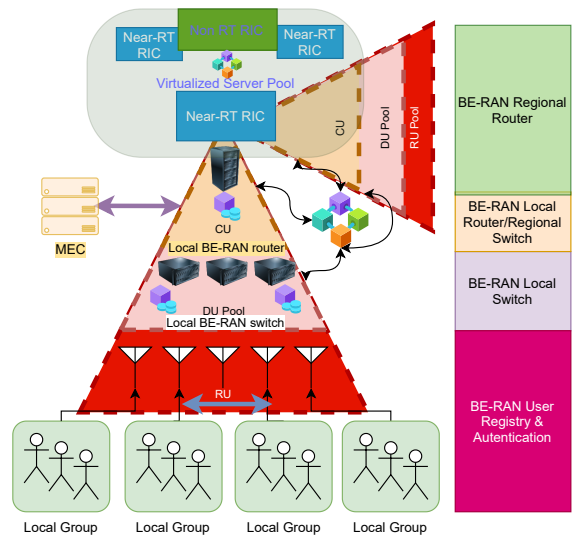

Fig. 2. BE-RAN architecture with network layers

The most fundamental parts of BE-RAN are the identity management and mutual authentication, with the feasibility at UEs and their attach-request during random access to RAN for better locality and latency. Once the UE registry is completed, BE-RAN is able to provide UEs with ad hoc network switching to facilitate further UE to UE mutual authentication if the intended users is within the reach of groups served by the same DU, indicated as Local Group in Fig. 2, with benefits of privacy-enhanced and lower latency network. As for RAN elements, in the time advanced operation, they are known to each other not only by conventional RAN element ID and PKI-based credentials, but also blockchain address association in parallel, in case the attack on the CA or other PKI resources.

In the case of out of reach at Layer 2 DU, with viable interfaces to upper CU or DUs with in the same resource pool (of physical servers), as shown in Fig. 2, BE-RAN encourages the traffic to be lifted to the upper layer with BE-RAN specific packet header and configurations. At the CU level, BE-RAN is able to couple with routing service and deploy firewalls

and other traffic policies for reinforced security for both UE and RAN elements. Besides, MEC joins the BE-RAN at the network layer, as shown in Fig. 2 right-hand-side, with the filtration of MEC Blockchain Address (BC ADD or BC-ADD) bounded traffic, MEC interacts with all UEs and RAN elements following procedures as mentioned above.

In the end, if the RAN runs the majority of the traffic in the BE-RAN regime, it effectively becomes an Edge Network with the absence of CN. Having the BE-RAN characteristics recognized in RAN intelligent controller (RIC), Edge Networks are able to perform more sophisticated service and policies to connected UEs and RAN elements, such as zero-rated service, QoS, QoE, etc.

### A. Framework

The BE-RAN formation, which consists of the top-level elements, which are RICs, and lower-level RAN elements, which are DUs and CUs, are illustrated in the following diagram of Fig. 2, where BE-RAN is illustrated with local groups of users who share the same RU, DU pool and CU for basic RAN functional split option 7.2, defined by 3GPP [19], in which case, the RU, DU, CU are layered as shown in Fig. 2, with an explainer case study shown in Fig. 3. The blockchain usage spans over all BE-RAN elements except RU due to lack of coded information at the RU PHY interface. The services of BE-RAN are roughly classed into four levels by starting with BE-RAN User/UE registry to local and regional switching and routing, powered by mutual authentication protocols, illustrated in Fig. 4.

The distributed BE-RAN architecture also takes advantage of virtualized hosting of logical RAN elements by making the blockchain node a communal node for all RAN logical units. It also benefits from RICs for policing and QoS potential by influencing RIC and administration of control panel interface. It is worth pointing out that the communication link can be set up between UE-UE, UE-RAN element, RAN element-RAN element, etc., as long as the interfaces are given BC-ADDs. The framework suggested in this paper does not restrict the network topology either the roles of users in more general considerations, but the paper is scoped to cover RAN as much as possible.

### B. Entities and Functions

The service has three primary parts: UE, RAN elements, and blockchain node, which is integrated with UE and RAN elements. The blockchain node in the RAN is slightly different and more potent than the one in UE, but they are the same distributed ledger with blockchain protocols. The RAN elements are detailed with RU, DU, and CU explanations below.

- UE: defined as any UE with potential access capability to RAN. It runs a light-weight blockchain node and fully capable of handling the BE-RAN MAC frame, as seen in Fig. 3, and other BE-RAN defined packets, which are under development. A UE knows another UE's blockchain address as a trusted identity, just like the mobile phone number is used in daily life. A UE is always with a physical address connected to switches or routers

(logically at RAN or physically at any network) if the UE is online.

- Blockchain node: defined as a logical blockchain node, hosted inside a UE or RAN element (e.g., DU). It keeps a shared ledger with blockchain data structure and synchronization between other blockchain nodes of UE and DU. The blockchain node is synced up using the IP packet in regular operation, but also operational during MAC frame registration service, where the capability is limited. However, the blockchain node should be considered as an application layer service with data read and write at the MAC layer.
- RU: defined as the physical radio unit with radio interfaces at Layer 1, the common functions of RU are receiving (decoding) and transmitting (coding) IQ sampled data from and to the radio front end, and with other functions defined in RAN functional split option 7.2, defined by 3GPP.
- DU: defined as a logical unit that serve the middle-haul data to CU and process fronthaul data from RU. It contains MAC and RLC protocols at Layer 2. DU's physical form is restricted to COTS computing hardware, as the blockchain node service requires universal computing capacity for the ease of integration. In most cases, it follows RAN lower layer split option 7.2 for the rest of functions [13].
- Blockchain Address (BC ADD or BC-ADD): is a short form of blockchain wallet address, where each user generates its own wallet address by hashing their public keys. It is the main item and identity that the ledger records and is used as the user's public anonymous identity both globally and locally. During the initial exchange of BC-ADD between contacts, the BC-ADD should be treated as a secret via secured channels and only known to trusted recipients to avoid spoofing.
- Blockchain-enabled Switch (BE-RAN Switch, BE-switch): is a modified switch, which reads the BE MAC Frame, matches with existing blockchain registration of paired BC-ADD and MAC ADD on the MAC layer.
- Blockchain-enabled Router (BE-RAN Router, BE-router): is a modified router, which reads the BE packet on the network layer, forwarding the traffic referencing to existing blockchain registration of paired BC-ADD and IP address.

### C. Stakeholders and intended services

- A user is defined as a UE or RAN element with blockchain client (BE-UE), signed in with a blockchain wallet address open to public/internal networks. Paging will be enabled using blockchain directory by switching and routing service, as seen in Fig. 2.
- Existing RAN elements play the role of miners, communicate and sync using interconnect interface, e.g., X2/E2, in order to host a functional network.
- Mutual authentication is achieved by signing and verifying the private keys and signatures of both BC-ADD holders, illustrated in Fig. 4.

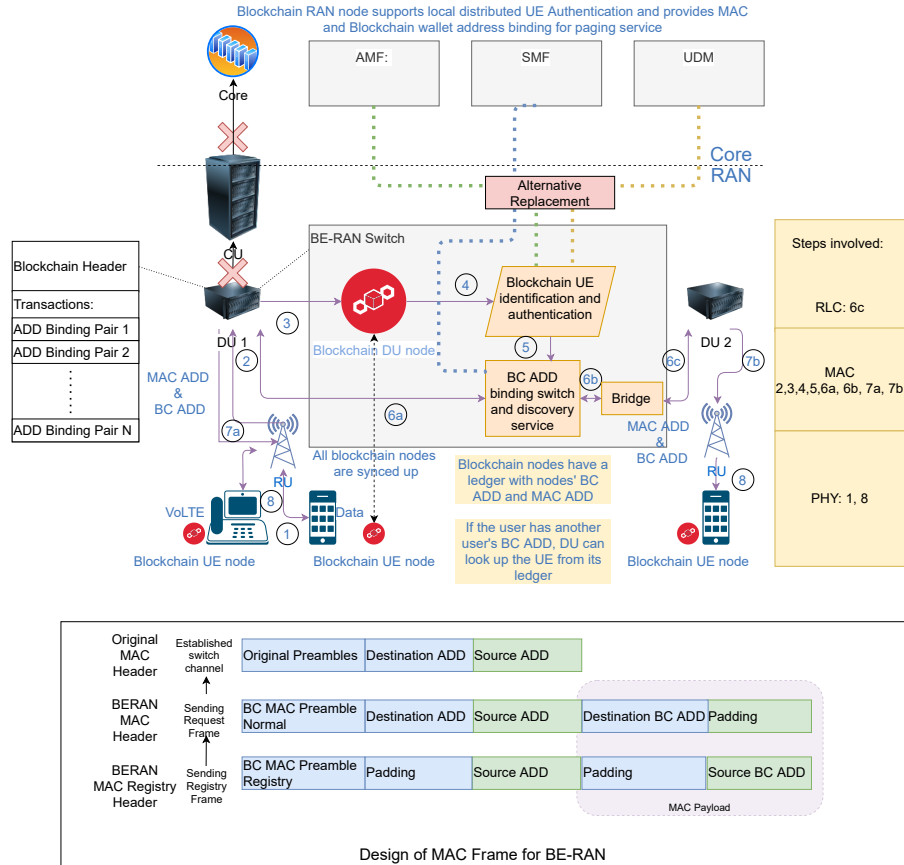

Fig. 3. Framework and Frame structure of BE-RAN at Layer 2/MAC layer

- The privacy-preserving feature is done by the anonymous blockchain address and its association with the actual global/temporary physical address, such as MAC address and IP address.
- The routing and switching service of BE-RAN is achieved by UE attachment encapsulation above MAC and Network Layer. Switching service is achieved by the altered frame structure, illustrated in Fig. 3.
- In the case of billing service is enabled across the service, its balance can be checked easily either in account model or Unspent transaction output (UTXO) model, where the token is inclusively generated by mining activities of the blockchain miners.
- We use the blockchain address and its balance to determine if the user is a legitimate user of the BE-RAN.

#### IV. BE-RAN SECURITY AND PRIVACY-PRESERVING COMMUNICATION

##### A. Mutual Authentication

Mutual authentication indicates that two individuals authenticate each other simultaneously before transmitting any data [20]. BE-RAN mutual authentication takes full advantages of blockchain features by binding the (global) BC ADD with

the actual (local and temporary) physical (rout-able) addresses (ADD); the mutual authentication is user-centric with their independent identity management, and it is an inclusive solution in addition to traditional mutual authentication, which is through the CN or third-party PKI [21], e.g., password-based scheme and certificate-based scheme. The distributed mutual authentication facilitates not only authentications at RAN, but also applies to broader application scenarios, with the power of distributed identity management.

The BE-RAN mutual authentication overcomes the needs of third-party trust while maintaining strong identity security among peers. The key relationship between public key (PK) and BC ADD is strictly one way, because the BC ADD is obtained by hashing its PK, which is de facto for blockchain address generation. Hence, the recipient can easily verify the legitimacy of proclaimed binding BC ADD and physical address by checking the sender's PK. Since the hashing of PK is one-way, it is hard to fake a blockchain address if the PK is known, vice versa. Furthermore, the PK is verified by checking the sender's signature, hence authenticating one side's identity. Detailed BC ADD and ADD binding is illustrated in Fig. 4's registry message.

Since the claimed bindings of *BCADD* and *ADD* cannot be convinced due to the zero-trust model, a second step authen-

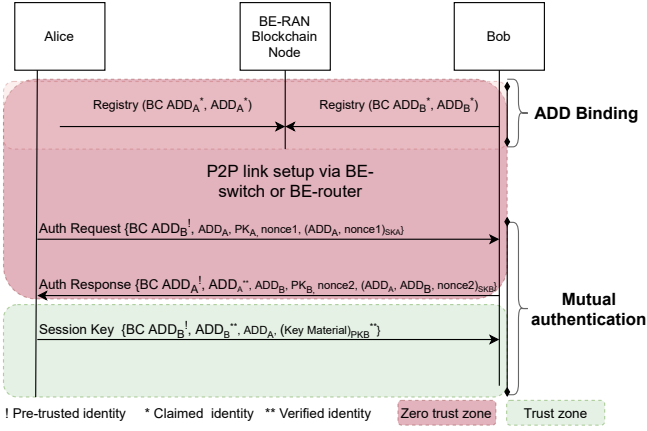

Fig. 4. Mutual authentication of BE-RAN

tification is required. Although each UE/RAN element registers the binding to the BE-RAN blockchain node and is learned by BE-switch/router, this binding cannot be trusted without mutual authentication. The authentication is executed between two UEs/elements to authenticate each other's binding and generates the session key, once the authentication is done, in order to secure following end-to-end communication. The detailed procedures are as shown in Fig. 4 with the mutual authentication between Alice and Bob.

- 1) Alice  $\rightarrow$  Bob: Authentication Request

$$\{BCADD_B^!, ADD_A, PK_A, nonce1, (ADD_A, nonce1)_{SK_A}\}$$

Alice sends the pre-trusted  $BCADD_B$ , its address  $ADD_A$ , its public key  $PK_A$ , and a random number  $nonce1$  with a signature of  $(ADD_A, nonce1)$  by using its private key  $SK_A$  to Bob. The  $nonce1$  is introduced to prevent multiple types attacks on integrity and prevent man-in-the-middle threats.

- 2) Bob  $\rightarrow$  Alice: Authentication Response

Upon reception of the Authentication Request from Alice in 1), Bob first checks if the claimed  $PK_A$  can derive  $BCADD_A$ . If it matches pre-trusted  $BCADD_A$ , the claimed  $PK_A$  belongs to  $BCADD_A$ .

In the next step, Bob uses  $PK_A$  to verify the signature signed by Alice's private key, noted by  $SK_A$ , to check if the decrypted  $nonce1$  from the signature is equal to the claimed  $nonce1$ , to prevent replay attack, so is the  $ADD_A$ .

Once Alice's authentication is done, Bob can believe this message is from  $BCADD_A$  because of matched records in both plain text and encrypted text signed by Alice's private key.

Then, Bob constructs Authentication Response to Alice.

$$\{BCADD_A^!, ADD_A^{**}, ADD_B, PK_B, nonce2, (ADD_A, ADD_B, nonce2)_{SK_B}\}$$

- 3) Alice  $\rightarrow$  Bob: Session Key Confirmation

After received Authentication Response from Bob, detailed in 2), Alice checks if this message is from Bob by validating  $PK_B$  and  $BCADD_B$ , with one more verification of  $ADD_B$  by comparing the plain text and decrypted  $ADD_B$  from  $SK_B$  encrypted message. Then, it chooses a session key or generates a session key by using the  $nonce1$  and  $nonce2$  for key negotiation and sends the session key confirmation message to Bob.

$$\{BCADD^!, ADD_B^{**}, ADD_A, (KeyMaterial)_{PK_B^{**}}\}$$

- 4) Once the session key has been exchange, a secured communication channel is set up with proposed mutual authentication protocol.

By completing mutual authentication without third-party involvement, users' privacy is kept to their own with easy identity management, as the blockchain address can be kept the same as a mobile phone number or e-mail address in the era of decentralization. BE-RAN mutual authentication is a great help to solve the identity crisis in cybersecurity and communication security. RAN elements with BE-RAN can easily verify other RAN elements within or among other RAN networks, as the RAN elements are now globally authenticated. A great use case of it would be stopping fake basestation. Once the UE has a list of trusted basestations from a trusted blockchain ledger maintained by communities and MNOs (the temper-proof and consensus will ensure the correctness of record), it will never connect to unauthorized basestations.

### B. Independent RAN operation and alternative billing on RAN

As indicated in the proposed framework, while the most traffic happens internally, the RAN is solely operating on its own with most service capability, such as voice/data service for the general public. It becomes a new operation model for MNOs and private or even virtual MNOs.

Most importantly, BE-RAN enables D2D communication been authenticated more locally than ever, as 3GPP defined D2D communication requires CN involvement due to the security concerns on identity authentication. In addition, billing on RAN usage ideally resides on the blockchain function, where the operators may choose to make BE-RAN with tokens that universal to all stakeholders, with strong initiatives opening up the sharing of RAN to other MNOs and private sectors. BE-RAN opens up new business models that will thrive both MNOs and their customers.

### C. Privacy-preserving P2P communication by RAN

P2P communication was introduced earlier to conclude that the real P2P was hardly feasible among Internet and current communication infrastructure, neither privacy-preserving. Every time there is an E2E communication, the OTP/internet service providers will always know the traces of two parties with their actual identity entry at ISP/MNO for regulation purposes. Taking the example of bitcoin network [15], due to the necessity of central routing service or third-party discovery,

e.g., DNS and peer discovery, to lookup IP addresses, such bitcoin communication is E2E communication supported by Peer-to-Peer network over Internet infrastructure, which indicates that bitcoin network as a Peer-to-Peer network is built upon the centralized communication network model and infrastructure. It leaves the network vulnerability and privacy concerns to end-users, as user discovery relies on other network peers.

To tackle the ground challenges of privacy, BE-RAN provides users with strong confidence in their anonymity on the communication they are about to set up. First of all, the authors fully agree that the regulator should have the chance to regulate the real-world identity of any subscriber for law enforcement and criminal investigation if the jurisdiction asks so. However, there are huge risks of privacy breaches when the records are not managed accordingly or misused by authorities and individuals. Secondly, BE-RAN employs user-centric identity management, meaning there is no risk of keeping a vulnerable identity database on any machine. A user only uses blockchain addresses to contact each other, and the record kept by users is the name of the contact and his BC ADD, nothing else. No other authorities/agencies have touches on the whole picture of identity anymore, as the physical address is only used when the user-self claims it and changes it at will. Last but not least, the mutual authentication integrates key negotiation and other crypto-suites to set up E2E encryption once the handshakes are done.

The above measures give the user confidence in privacy and raise the difficulty for regulation. As a new service for operators, regulation cannot be ignored against national and international laws. If MNOs configure their RAN elements to only accept a list of BC ADD or IMEI, and make Know-Your-Customer (KYC) registration compulsory for users, it regulates the user from malicious and illegal activities for community/national interest.

## V. BE-RAN FOR EMERGENCY SERVICE: A CASE STUDY

BE-RAN has the potential to be the backbone of emergency service, with user-centric identity with mutual authentication and Layer 2 Blockchain-enabled switch (BE-switch) integrated with DU. We have simulated an emergency situation, i.e., natural disasters, public infrastructure outage, etc., when the RAN has lost its connections between CU and DU, also between RAN and CN. DU, as a distributed unit, has a greater survival rate with its connected RU, compared to the connection of CU and DU, and CU to CN, since the number of physical connections are taking into account.

### A. DU Subnet Architecture

The architecture of the proposed BE-RAN consists of only UE and RAN with RU and DU. However, the architecture of BE-RAN should also work with added CU. In the BE-RAN design, CN is excluded from architecture for standalone RAN service with blockchain. However, the CN can blend with BE-RAN and take advantage of all security and billing features empowered by blockchain.

In a typical operation of BE-RAN and 3GPP-defined RAN, a UE follows the random access protocols to attach to a RU.

However, due to the broken uplink to the CU and CN, the standard authentication cannot be conducted by CN. Hence, the UE needs to specify the required access during random access procedures. For ease of understanding, there are 8 steps from a UE calling another UE in Fig. 3, following mutual authentication protocols described in Fig. 4. And one additional step to exchange UE's encrypted or plaintext BC ADD outside the BE-RAN workflow is required. The overall message flow is detailed in Section V-B where the extra steps for mutual authentication are omitted.

- UE initiates the service and attaches to RU, as shown in step 1 of Fig. 3, and the RU sends the PHY towards DU, in step 2.
- The DU reads the MAC ADD of UE and the BC ADD from the BE MAC frame header and passes them to the blockchain node, as shown in step 3.
- BC node writes the UE BC ADD and MAC ADD binding as UE identity to the blockchain ledger to facilitate further UE authentication, in step 4.
- Blockchain-enabled switch lookups the switch table to set up the channel between the initiating UE and requested UE (if the record has been registered), in step 5.
- Once a valid record pair has been linked by the BE-switch, the BE-switch starts to forward the MAC frame to the requested UE via DU and RU, as illustrated in steps 6a and 7a. However, if the MAC address is not locally reachable but via a bridge to other DU domains, the BE-switch forward the packet to the bridge and then the destination DU and RU to the destination UE step 6b, 6c, and 7b.
- Once the destination RU receives the DU's valid control message to forward the packet, and the RU will start the BE-RAN service with designated UEs, as shown in step 8.

Besides the de facto mutual authentication between UEs, there is a great use of mutual authentication for RAN elements since the RAN has lost its CA and other PKI for RAN elements authentication. A DU can easily authenticate other DU with a preloaded table of trusted RAN elements BC ADD if it is reachable via existing links. From there, the BE-RAN mutual authentication takes over identity management of RAN and allows secured communication between any discovered RAN elements. Note that, if in the case the UE needs to contact RAN elements, it can also use BC ADD to achieve direct communication to RAN control plane (UE-RAN elements link), if the control plane chooses to be accessible by BC ADD, which is not possible in traditional RAN.

### B. Message flow

The message flow between UEs, RU, DU BC nodes, and DU BE-switch are shown as an example, illustrated in Fig. 5. The steps are significant less if the authentication is done by D2D, without BE-switch or BE-router.

Before the BE-RAN authentication, UE's blockchain address is known to the contacts by exchanging it through a secured channel, e.g., D2D, encrypted emails, messaging apps, Bluetooth, WiFi direct, etc. The general assumption and



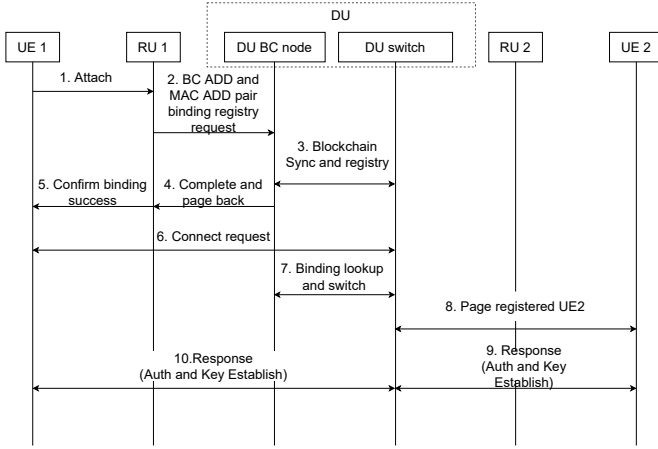

Fig. 5. Message flow of BE-RAN for emergency service of DU subnet

requirement of BC ADD are that the sender should have the correct recipient BC ADD. Users have the responsibility to keep the BC ADD confidential to prevent malicious attacks of UE BC ADD spoofing even though the spoofing will be prevented by BE-RAN mutual authentication but wasting blockchain resources.

UE sends attach message 1 (msg 1) to RU, and initiates BC ADD binding with its MAC ADD. The registry is carried by msg 2, and the blockchain node of DU updates its record and syncs up with the UE node in the later stage, as indicated by msg 3. Once the registry is complete, the DU BC node notify RU and UE with the success notification via msg 4 and msg 5.

Upon the reception of success notification, UE sends out connect request in msg 6 to BE-switch, and BE-switch looks up its records of BC ADD and MAC ADD bindings to offer switch service to UE, represented by msg 7. The following control message of msg 8, which includes steps 1-5 for registry purpose, reaches destination UE and finishes the first handshake. Once the link is ready, the destination UE will page the source UE to confirm the success of the connection via msg 9 and msg 10, and the link will be ready for the next steps, including authentication and session key establishment, etc.

## VI. RESULTS

As the BE-RAN is a framework with two basic function groups, it requires attention to performance on mutual authentications. The results of BE-RAN are presented regarding the communication and computation metrics. The comparable protocol stacks are commonly found in Transportation Layer or Network Layer. We have selected a few iconic stacks for benchmarking purposes, they are IKEv2 and TLS.

### A. Performance analysis of Mutual Authentication Protocols: signals, communication and computation

To compare the protocols as mentioned above, the scope is limited to public-key authentication schemes, which are suitable for mutual authentication. We choose the common

practices in cellular networks: certificate-based IKEv2 and both certificate-based or public-key-based TLS 1.3 [14], to compare with BE-RAN mutual authentication in signaling, communication, and computation perspectives. To simplify the comparison, optional configuration parameters, such as algorithm, IKE header, etc, are ignored. The optional payloads, such as *CERTREQ* for IKEv2, a list of trust anchors and integrity checks, are also excluded from comparisons, as seen in Table I. Only the necessary parameters and simplest form of authentications are included in comparing fairness of size and computing requirement.

IKEv2, a certificate-based mutual authentication protocol, includes two phases: Initial Exchange (*IKE – INIT*) and Authentication Exchange (*IKE – AUTH*) to help achieve authentication and establish a security association (SA). There are two signal messages in *IKE – INIT*, both of them contain nonce and (*EC*)*DH* Parameter (*EC* stands for elliptical curve based Diffie-Hellman parameter) to calculate a *KEYSEED*, a handshake secret of IKEv2. Then, several keys are derived from *keyseed* to protect the secrecy and integrity of signal messages in *IKE – AUTH*. For the detailed two signal messages in *IKE – AUTH*, both of them contain the sender's ID, the sender's certificate, and an *AUTH* value, which is a signature value for authentication and calculated by the message (sender's ID, sender's certificate) appended with nonce and output of Pseudo-Random Function, aka. *prf()* function.

TLS, a certificate/public key-based protocol, is widely used on the Internet. TLS version 1.3, which is the currently common practice, its handshakes include the following procedures: Client\_Hello, Server\_Hello, Encrypted\_Extensions, Server Certificate Request, Server Certificate, Server Certificate Verify, Server Finished, Client Certificate, Client Certificate Verify, Client Finished. To normalize the comparison, signal messages like Encrypted\_Extensions and some configure parameters, including algorithm, version, etc., are omitted. The authentication procedure of TLS 1.3 is described as follows: The Client\_Hello and Server\_Hello contain nonce and (*EC*)*DHE* parameter. After the Client\_Hello and Server\_Hello, a handshake secret is generated by (*EC*)*DHE*. Then, keys derived from this handshake secret will encrypt the subsequent signal messages. The message Certificate\_Request contains request context strings. The message Certificate contains certificate or raw public key. The message Certificate\_Verify is a signature over the entire handshake by using Transcript Hash. The message *Finished* is a MAC value over the entire handshake.

- Signal overhead and environment (external) overhead: For signaling overhead, the BE-RAN mutual authentication scheme only requires 2 signals. The IKEv2 executes *IKE – INIT* to protect the following authentication, it needs 4 signals. The TLS 1.3, except the message Encrypted\_Extensions, it needs 9 signals with separated requests and verifies. It also requires a (*EC*)*DH* exchange to protect the following authentication procedure. Besides signaling cost, environment overhead is defined as the infrastructure cost to run the above protocols, particularly for BE-RAN, as BE-RAN has a dependency

TABLE I  
COMPARISON TABLE OF SELECTED COMMON MUTUAL AUTHENTICATION PROTOCOLS

	Communication Overhead					Computation Overhead				
	signal 1 (bits)	signal 2 (bits)	signal 3 (bits)	signal 4 (bits)	signal 5-9 (bits)					
BE-RAN	784 <sup>1</sup> +2ADD+PK	784 <sup>1</sup> +4ADD+PK	0	0	0	0	0	0	0	$2T_{sign} + 2T_{verify} + 2T_{hash}$
IKEv2	(EC)DHPara+nonce	(EC)DHPara+nonce	2ADD+2CERT+nonce+prf()	2ADD+2CERT+nonce+prf()	0	0	0	0	0	$T_{(EC)DH} + 4T_{sym} + 4T_{hmac} + 2T_{sign} + 2T_{verify}$
TLS 1.3	(EC)DHPara+nonce	(EC)DHPara+nonce	ignored <sup>2</sup>	CERT or PK	hash (sign.)	hmac	CERT or PK	hash (sign.)	hmac	$T_{(EC)DH} + 14T_{sym} + 2T_{sign} + 2T_{hash} + 2T_{verify} + 2T_{hmac}$

TABLE II  
TABLE OF PARAMETERS

Abbr.	Name	Length <sup>3</sup>
IKEv2	Internet Key Exchange v2	N/A
TLS	Transport Layer Security	N/A
(EC)DHPara	Elliptical Curve DH parameters	256 bits
DHPara	DH parameters	3072 bits
nonce	A nonce by prf()	256 bits
ADD	IPv6 address	128 bits
prf()	Output of Pseudo-random functions	=256 bits <sup>4</sup>
CERT	X.509v3 Certificate(s)	5592 bits
PK (RSA/DSA)	Public key with RSA or DSA	3072 bits
SK (RSA/DSA)	Private key with RSA or DSA	256 bits
PK (ECDSA)	Public key with ECDSA	256 bits
SK (ECDSA)	Private key with ECDSA	256 bits
hash(sign.)	A hashed signature using SHA256	256 bits
hmac	A hmac value	256 bits
$T_{pm}$	Time of a scale multiplication	0.906 ms
$T_{exp}$	Time of a modular exponentiation	0.925 ms
$T_{hash}$	Time of a hash operation	0.5 us
$T_{signR}$	Time of a sign. operation for RSA	1.506 ms
$T_{verifyR}$	Time of a verify operation for RSA	0.03ms
$T_{signE}$	Time of a sign. operation for ECDSA	0.016 ms
$T_{verifyE}$	Time of a verify operation for ECDSA	0.1 ms
$T_{sym}$	Time of a symm. key operation	3 us
$T_{hmac}$	Time of a hmac operation	1.4 us
$T_{DH}$	Time of a DHPara operation	1.812 ms
$T_{ECDH}$	Time of a ECDHPara operation	2.132 ms

on the underlying blockchain platform. Meanwhile, it is also a case for all certificate-based solutions as CA's cost is external to the protocols. In the deployment of BE-RAN, the consensus choice varies the communication and computational cost. As the distributed system's nature tends to be heavier on communication, the cost of running BE-RAN should be optimized for external communication overhead. In the scope of BE-RAN mutual authentication, there is no such cost, as the information of users' blockchain address is assumed synced, which is also true for a static BE-RAN deployment. For the blockchain computational cost, depending on the consensus mechanisms, it should be assessed on the specific consensus and exceeds this paper's scope.

- Communication overhead: According to the standards of TLS 1.3, IKEv2, and NIST standards, we assume the length of the nonce is 256 bit, the output length of Hash()

<sup>1</sup>The size of 2 nonce and a blockchain address

<sup>2</sup>Parameters ignored due to optional requirements.

<sup>3</sup>Size of parameters are obtained from standard documents, approximate time value are obtained from the hardware described in Section VI-A-b.

<sup>4</sup>The length of prf() output is the same as its input.

is 256 bit, the length of prf() is equal to the key, which is also 256 in our test setup. To achieve the required security level, we assume the public key of finite-field cryptography is 3072 bits, and the private key is 256 bits. Also, the key of algorithms based on elliptic curve cryptography (ECC) is 256 bits. Also, we assume the length of BCC ADD is 272 bit.

According to the examples in RFC 2459, a x.509 version 3 certificate's length can be 730/675/699 bytes, and the standards of IKEv2 specifies the ID in IKEv2 can be IPv4/IPv6 Address, FQDN ID, RFC 822 email address, etc. So here, we use IPv6 address to replace *ID* in IKEv2, which is 128 bits.

- Computation overhead: We assume  $T_{sym}$  to represent the time of symmetric encryption and decryption,  $T_{sign}$  to present the consuming time of signature by private key,  $T_{verify}$  to present the consuming time of verification by public key,  $T_{hmac}$  to represent time of hmac operation,  $T_{hash}$  to represent time of hash operation,  $T_{(EC)DH}$  to present the time of (EC)DH operation,  $T_{pm}$  to present time of ECC-based scale multiplication, and  $T_{exp}$  to present time of modular exponentiation. Thus, we have  $T_{DH} = 2T_{exp}$ , and  $T_{ECDH} = 2T_{pm}$ . Also, we ignore the execution time of prf() function. Besides the components of protocols, the default plaintext size, which is used across all computational benchmark, for algorithms benchmark is chosen at 1024 bytes, and the length of certificate is set at 5592 bit (699 bytes) from RFC 2459 example.

## B. Communication overhead comparisons

By adding the length of authentication signal messages communication overhead. In the following comparison, a group of most commonly used authentication protocols and public-key options, namely, IKEv2 with RSA and ECDSA, TLS 1.3 with RSA and ECDSA, are selected as the baseline for proposed BE-RAN mutual authentication protocols. As indicated by Fig. 6 (note that the unit has been converted to bytes for shortening numbers), BE-RAN yields better Finite Field-based algorithms, e.g., RSA, in the test, and has similar (356 bytes vs. 320 bytes by TLS) performance against TLS in terms of ECC-based algorithms. The communication overhead results suggest BE-RAN has good potential to be used in high performance and low latency authentication. Note that, as discussed in external overhead, the cost of running blockchain infrastructure and other external environments are not considered for BE-RAN, either for IKEv2 and TLS 1.3.

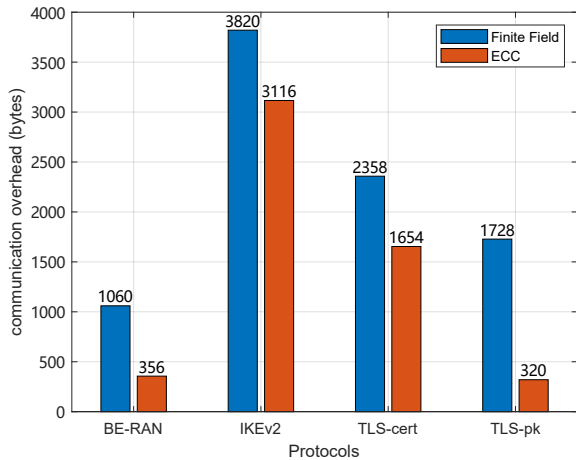

Fig. 6. Communication overheads for Finite field and ECC crypto protocols

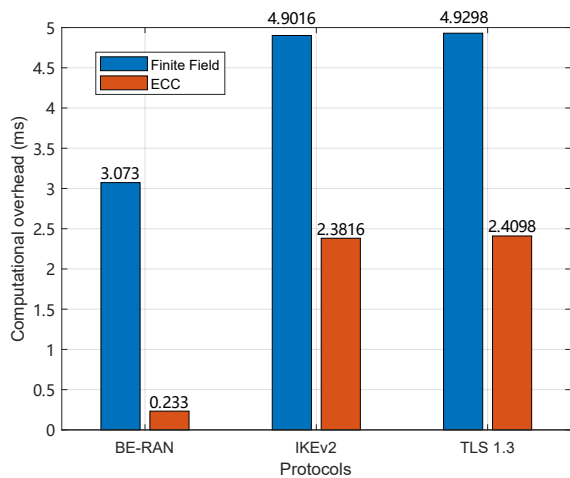

Fig. 7. Computational overhead for Finite field and ECC crypto protocols

### C. Computational overhead benchmark

The computational overhead is measured by the execution time of protocols, conducted on Ubuntu 20.04.1 4GB RAM at 3200 MHz, with 4 Cores at 4.2 GHz virtualized on PC with Windows 10 installed. With the same physical environment, the computational overhead is measurable by comparing the execution time on the same platform, listed in Table. II. Selected authentication protocols are IKEv2 with RSA/ECDSA, TLS 1.3 with RSA/ECDSA and BE-RAN with RSA/ECDSA.

The benchmarked results of all computational components are listed in Table II, and the comparison of selected protocols are shown in Fig. 7. The result of the computational comparison shows BE-RAN has significant improvement on Finite-Field-based algorithms, e.g., RSA and DSA, and outperformed other protocols by a considerable margin with the elliptical curve method. The ECC-based results provide a good foundation for BE-RAN to be used in IoT and other thin-clients due to the lighter authentication cost.

## VII. CHALLENGES AND FUTURE WORK

### A. Widening the scope of BE-RAN mutual authentication

A protocol designed for BE-RAN mutual authentication also works in any network with appropriate blockchain integration. It means that the third-party trust can be perished with no effort, a great aid to PKI-based security architecture, as long as the blockchain ledger is synchronized across the network. The two-phases zero-trust model can be a good practice of distributed identity management and authentication.

With the help of BE-RAN mutual authentication, the challenge of running blockchain across the network is unavoidable, and the throughput and latency will bring new challenges to the scalability and performance of authentication protocol. And indeed, the blockchain was chosen as an ideal medium for the proposed work. However, the search for other alternative distributed ledger technology may open a new door to large-scale mutual authentication, with the breakthrough of throughput.

### B. Blockchain node span on low layer element

Blockchain was seldom considered viable on lower layers of OSI model, e.g., MAC Layer and Network/Transport Layer [15], as the current state-of-the-art blockchain protocols stacks live on the application layer, with most of the encryption suites only available to high-level applications. In the BE-RAN operation model, there is a range of services available to users at different layers. It is an educated guess that the CU has full capability to operate blockchain node in its full function, hence no concerns of service degradation if CU is available. However, if the DU is restrained to a non-universal computing architecture, integrations of blockchain nodes may be difficult for such devices. Hence, the service degradation is imminent, though the BE-RAN is completely backward-compatible with any ordinary Ethernet switch or DU.

### C. BE-RAN switching

BE-RAN empowers a blockchain-enabled switching mechanism as indicated in Fig. 3. Hence, the integration of BE-switch is necessary for the regular operation of BE-RAN at the MAC layer. The current configurable switch with open sources and license should have everything needed for BE-RAN operation, but a detailed switch protocol and standardization should be considered a high priority. In addition, a potential MACsec patch can be achieved using BE-RAN architecture and mutual authentication.

### D. BE-RAN routing

Having the switch is not enough to reach a broader range of UEs and RAN elements. Therefore, the routing at higher network layers is also necessary for expanding the capacity of BE-RAN. The major challenges are BE-RAN packets' compatibility and the ability to pass on blockchain synchronization messages with solely modified preambles of packets, meaning the synchronization is done automatically through the network handshakes. And the integration of BE-RAN protocols on existing routers is challenged by hardware adoption

and backward compatibility. As the BE-RAN packet becomes an extra field in the packet, it can also contribute to IPsec to improve IPsec authentication methodology. The detailed routing mechanism and protocol are under development with careful consideration given to security and performance.

#### E. Turning RAN into local wireless controllers

With RAN's locally sourced radio transceivers, the local wireless controller benefits from higher power, more comprehensive coverage, and a licensed spectrum to provide better SNR and control radius to local users, such as Autonomous Guided Vehicle (AGV), drones, and IoT device. BE-RAN enables the basestation to be used as wireless boosters for controllers connected to the basestation, along with low latency features thanks to a distributed architecture.

#### F. BE-RAN QoS and billing

Enabling the network function of BE-RAN is the first step of operation, to couple with breach of user-centric fair-use policy, higher-level supervision of network health, and the management of traffic quality and experience, are scoped in the BE-RAN architecture and awaits further work. The actual deployment model of QoS of BE-RAN may happen at any layer of RAN elements, not inclusive for RAN elements but UEs. With the user-centric methodology in mind, a punishment and incite can be easily performed on the blockchain with consensus done by quorum, e.g., MNOs, leased RAN maintainers, and other majority UEs, by banning or denying the access of particular UE/element from further registration on the blockchain.

Since the blockchain nodes require computing and communication resources for network maintaining, it is reasonable to charge the user when they declare address bindings on the blockchain and charges them more when the actual communication traffic happens on RAN. The integrated billing is viable in BE-switch and BE-router, with additional service charges happens at RICs.

### VIII. CONCLUSIONS

The proposed blockchain-enabled radio access network has full potential to be a decentralized privacy-preserving P2P communication system with secured identity management powered by mutual authentication. It enables the RAN to operate without CN's involvement and boasting the eco-system of distributed and decentralized communications and applications from the edge network to D2D applications with significant performance improvement on existing authentication protocols while enabling the user-centric identity management. With the further development of the BE-RAN switch and router, new operation models for mobile network operators are rising from the dawn of the decentralization age. As the RAN evolution has taken place at the O-RAN alliance, the trend of taking blockchain for its security and distributed alternative architecture is evident. Open RAN with O-RAN alliance may make most of the benefits offered by blockchain and makes it future-proof with limitless applications.

### REFERENCES

- [1] C.L. I, C. Rowell, S. Han, Z. Xu, G. Li, and Z. Pan, "Toward green and soft: A 5G perspective," *IEEE Communications Magazine*, vol. 52, no. 2, pp. 66–73, 2014.
- [2] Y. Sun, L. Zhang, G. Feng, B. Yang, B. Cao, and M. A. Imran, "Blockchain-Enabled Wireless Internet of Things: Performance Analysis and Optimal Communication Node Deployment," *IEEE Internet of Things Journal*, vol. 6, no. 3, pp. 5791–5802, jun 2019.
- [3] D. Yu, W. Li, H. Xu, and L. Zhang, "Low Reliable and Low Latency Communications for Mission Critical Distributed Industrial Internet of Things," *IEEE Communications Letters*, vol. 25, no. 1, pp. 313–317, jan 2021.
- [4] C.L. I, S. Kuklinski, T. C. Chen, and L. L. Ladid, "A perspective of o-ran integration with mec, son, and network slicing in the 5g era," *IEEE Network*, vol. 34, no. 6, pp. 3–4, 2020.
- [5] A. Rostami, "Private 5G Networks for Vertical Industries: Deployment and Operation Models," in *2019 IEEE 2nd 5G World Forum (5GWF)*, 2019, pp. 433–439.
- [6] C.L. I, S. Han, Z. Xu, S. Wang, Q. Sun, and Y. Chen, "New Paradigm of 5G Wireless Internet," *IEEE Journal on Selected Areas in Communications*, vol. 34, no. 3, pp. 474–482, 2016.
- [7] C.L. I, J. Huang, R. Duan, C. Cui, J. Jiang, and L. Li, "Recent Progress on C-RAN Centralization and Cloudification," *IEEE Access*, vol. 2, pp. 1030–1039, 2014.
- [8] E. Westerberg, "4G/5G RAN architecture: How a split can make the difference," *Ericsson Review (English Edition)*, vol. 93, no. 2, pp. 52–65, 2016.
- [9] 3GPP, "NG-RAN; Architecture description (Release 15)," Tech. Rep., 2018. [Online]. Available: <https://www.3gpp.org/DynaReport/38401.htm>
- [10] H. Xu, P. V. Klaine, O. Onireti, B. Cao, M. Imran, and L. Zhang, "Blockchain-enabled resource management and sharing for 6G communications," *Digital Communications and Networks*, vol. 6, no. 3, pp. 261–269, aug 2020.
- [11] L. Zhang, A. Farhang, G. Feng, and O. Onireti, *Radio Access Network Slicing and Virtualization for 5G Vertical Industries*, ser. Wiley - IEEE. Wiley, 2020.
- [12] J. Yan, X. Hang, B. Yang, L. Su, and S. He, "Blockchain based PKI and Certificates Management in Mobile Networks," in *2020 IEEE 19th International Conference on Trust, Security and Privacy in Computing and Communications*, 2020, pp. 1764–1770.
- [13] O-RAN Alliance, "O-RAN-WG1.OAM-Architecture-v02.00," Tech. Rep., 2020. [Online]. Available: <https://www.o-ran.org/specifications/O-RANArchitectureDescription2.0>
- [14] A. Zvarico and S. Jeux, "The O-RAN ALLIANCE Security Task Group Tackles Security Challenges on All O-RAN Interfaces and Components," 2020. [Online]. Available: <https://www.o-ran.org/blog/2020/10/24/the-o-ran-alliance-security-task-group-tackles-security-challenges-on-all-o-ran-interfaces/>
- [15] S. Nakamoto, "Bitcoin: A peer-to-peer electronic cash system," 2008. [Online]. Available: <http://www.bitcoin.org/bitcoin.pdf>
- [16] L. Zhang, H. Xu, O. Onireti, M. A. Imran, and B. Cao, "How Much Communication Resource is Needed to Run a Wireless Blockchain Network?" jan 2021. [Online]. Available: <http://arxiv.org/abs/http://arxiv.org/abs/2101.10852>
- [17] X. Ling, J. Wang, Y. Le, Z. Ding, and X. Gao, "Blockchain Radio Access Network Beyond 5G," *IEEE Wireless Communications*, vol. 27, no. 6, pp. 160–168, 2020.
- [18] W. Tong, X. Dong, Y. Shen, and J. Zheng, "BC-RAN: Cloud radio access network enabled by blockchain for 5G," *Computer Communications*, vol. 162, pp. 179–186, 2020.
- [19] C. Harper and S. Sirotkin, *NG-RAN Architecture*. John Wiley & Sons, Ltd, 2021, ch. 4, pp. 123–234. [Online]. Available: <https://onlinelibrary.wiley.com/doi/abs/10.1002/9781119550921.ch4>
- [20] C. Wang and J. Feng, "A Study of Mutual Authentication for P2P Trust Management," in *2010 Sixth International Conference on Intelligent Information Hiding and Multimedia Signal Processing*, 2010, pp. 474–477.
- [21] Y. Sun, J. Cao, M. Ma, Y. Zhang, H. Li, and B. Niu, "Eap-ddba: Efficient anonymity proximity device discovery and batch authentication mechanism for massive d2d communication devices in 3gpp 5g hetnet," *IEEE Transactions on Dependable and Secure Computing*, 2020.