INTERPRETABLE POLICY SPECIFICATION AND SYNTHESIS THROUGH NATURAL LANGUAGE AND RL

A PREPRINT

Pradyumna Tambwekar
Georgia Institute of Technology
pradyumnat@gatech.edu

Andrew Silva
Georgia Institute of Technology
andrew.silva@gatech.edu

Nakul Gopalan
Georgia Institute of Technology
ngopalan@gatech.edu

Matthew Gombolay
Georgia Institute of Technology
matthew.gombolay@cc.gatech.edu

November 16, 2021

ABSTRACT

Policy specification is a process by which a human can initialize a robot’s behaviour and, in turn, warm-start policy optimization via Reinforcement Learning (RL). While policy specification/design is inherently a collaborative process, modern methods based on Learning from Demonstration or Deep RL lack the model interpretability and accessibility to be classified as such. Current state-of-the-art methods for policy specification rely on black-box models, which are an insufficient means of collaboration for non-expert users: These models provide no means of inspecting policies learnt by the agent and are not focused on creating a usable modality for teaching robot behaviour. In this paper, we propose a novel machine learning framework that enables humans to 1) specify, through natural language, interpretable policies in the form of easy-to-understand decision trees, 2) leverage these policies to warm-start reinforcement learning and 3) outperform baselines that lack our natural language initialization mechanism. We train our approach by collecting a first-of-its-kind corpus mapping free-form natural language policy descriptions to decision tree-based policies. We show that our novel framework translates natural language to decision trees with a 96% and 97% accuracy on a held-out corpus across two domains, respectively. Finally, we validate that policies initialized with natural language commands are able to significantly outperform relevant baselines ($p < 0.001$) that do not benefit from our natural language-based warm-start technique.

1 Introduction

In recent years, significant progress has been made towards developing collaborative human-robot techniques that allow humans to specify a robot’s behavior for completing a desired task, i.e. a robot policy. However, the future proliferation such of human-robot technology hinges on facilitating an accessible and interpretable means of interacting with a robot. Natural language provides one such modality. Through natural language, humans can easily program their desired robot behavior without prior experience. In this paper, we propose a methodology to specify intelligible policies from unstructured natural language and leverage these specifications to synthesize an improved policy via reinforcement learning.

To teach robot behavior via policy specification, researchers have often relied on Learning from Demonstration (LfD) and Reinforcement Learning (RL) approaches [Abbeel and Ng, 2004, Edwards et al., 2018, Cheng et al., 2018, Nair et al., 2018]. While LfD approaches are able to help reduce the time consumed during initial state exploration in RL, these methods can be data-inefficient and crucially are not a universally-intelligible Weld and Bansal [2019] means of policy specification from a human-labeling perspective. Specifically LfD methods are often difficult to navigate for a non-expert [Rana et al., 2020, Amershi et al., 2014]. Replacing physical demonstrations with language provides a natural means of transitioning to more accessible robot interactions [Gopalan et al., 2018, Tellex et al., 2020].

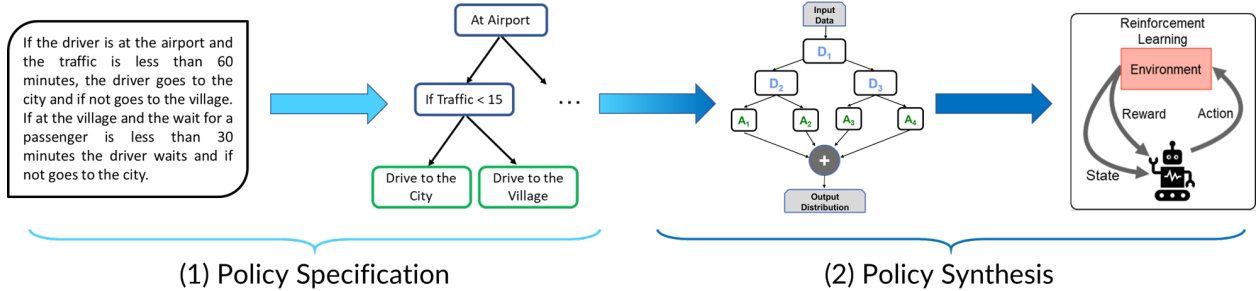

Figure 1: This figure provides a notional depiction of our entire pipeline. Policy descriptions are converted to lexical decision trees. Each of these decision trees is encoded as a differentiable decision tree to initialize the RL policy followed by policy gradients to facilitate policy learning.

Most modern methodologies to specify policies through language typically rely entirely on deep learning methods. While data- and compute-intensive, researchers have shown positive results in language grounding and navigation metrics for robotics [Blukis et al., 2019], embodied agent tasks [Misra et al., 2018], and more [Andreas et al., 2017]. However, such deep learning approaches lack interpretability and do not allow a novice user to inspect learned policies. Recent work on explainability has advocated for a shift from “model-centered” approaches towards deliberate design of systems that cater to human-factors Ehsan and Riedl [2020]. Reinforcement learning is no different; for end-users to effectively teach agent behaviour, our research focus must be on fostering the ability for humans to understand an agent’s decision-making Li et al. [2019].

Drawing from these human-centered insights, we contribute a novel ML framework for policy specification that enables humans to generate agent policies, in the form of a differentiable decision tree (DDT), from unstructured natural language descriptions. We leverage ProLoNets [Silva and Gombolay, 2020], a recently proposed framework allowing users to initialize both the structure and rules of a neural network by providing a decision tree. Unlike standard deep learning based policy representations, these networks can be discretized after training, thereby providing a means for a novice user to interpret a learned policy [Silva et al., 2020]. Furthermore, we show that optimized policies initialized via natural language significantly outperform those learnt without language initialization on two domains. This formulation captures the benefits of structural compositionality provided by the differential decision tree architecture with the ease of use of language to affect a more natural means of human-robot collaboration.

Our contributions are as follows:

1. We present our data collection methodology alongside the largest known dataset mapping unstructured natural language instructions to lexical decision tree-based policy specifications.
2. We formulate a novel machine learning architecture that accurately generates decision trees from natural language with a translation accuracy of 95.93% and 97.49% across two domains.
3. We demonstrate that these translated decision trees can successfully warm-start RL and outperform relevant baselines to highlight the efficacy of natural language initialization of ProLoNets ($p < 0.001$).

2 Related Work

We provide a brief overview of research in the areas of instruction following and interpretable machine learning.

Language to Policies – Traditional instruction following approaches involve translating natural language to a predicate-based language that is then planned over [Kress-Gazit and Fainekos, 2008, Tellex et al., 2011, Matuszek et al., 2013, Artzi and Zettlemoyer, 2013, Thomason et al., 2019]. For example, the sentence “move to the left” would map to the predicate function $move(a) \wedge dir(a, left)$. This process involves a high degree of feature engineering as both the grammar and the formalizing of the predicate specification require expert design. Some deep learning based approaches alleviate the dependency on a specified grammar for natural language [Gopalan et al., 2018, Arumugam et al., 2017]. However, these approaches still require hand engineering in the form of expert-specified predicate level information.

Recent approaches also consider mapping language directly into an agent’s policy [Hermann et al., 2017, Bahdanau et al., 2018, Blukis et al., 2018, 2019]. These approaches condition an agent’s policy via a combined learned embedding of the state representation and the natural language instruction. We differentiate ourselves from these approaches by providing a means of policy specification that is interpretable and accessible to novice users which also allows for neural gradient based policy improvement.

Interpretable ML – Prior work has defined interpretability as “the ability to explain or to present in an understandable way to humans” [Doshi-Velez and Kim, 2017]. One such approach is to visualize the intermediate outputs of a neural network [Simonyan et al., 2013, Selvaraju et al., 2017, Yosinski et al., 2015, Mott et al., 2019, Zahavy et al., 2016]. These types of approaches look to incorporate transparency within neural networks. However, there is ongoing debate over whether these latent representations in a high-dimensional space actually correspond to the meanings assigned to them [Montavon et al., 2018, Szegedy et al., 2013].

Other works have investigated approaches allowing non-experts to manually specify agent policies [Silva and Gombolay, 2020, Humbird et al., 2018]. By leveraging the hierarchical decision structure of these models; one can encode user-expertise into an interpretable structure where each propositional rule specified can be mapped to decision nodes in a tree. However, such approaches require humans to manually specify a set of propositional rules, in the form of a decision tree, which may not be a natural way to encode a desired agent policy. Furthermore, it was suggested that transparency, offered by decision trees, in isolation does not automatically facilitate interpretable models [Lipton, 2018]. Combining the compositional structure of decision trees with natural language initializations and explanations is more conducive towards a more intelligible policy specification methodology.

Filling the Gap – Overcoming these limitations in prior work, our approach generates high-quality agent policies via natural language without expert knowledge or intensive training procedures to learn the domain. Through the use of human-centered design, our approach provides an accessible means of initializing and interpreting RL agents.

3 Preliminaries

We first review RL, followed by an explanation of how differentiable decision trees can be used to encode policies. Finally, we describe a type of RNN that can generate hierarchical data, which we employ to generate decision trees.

Markov Decision Processes – Markov decision processes (MDPs) model a stochastic control process as a 5-tuple $M = \langle S, A, R, T, \gamma \rangle$. S and A represent the set of all possible states and actions respectively. R specifies a mapping to a reward signal based on the action taken by an agent within a specific state. The transition matrix T provides a probability distribution over states s' transitioned to when applying action a in state s and γ accounts for a discount factor to prioritize actions taken at earlier time-steps within the learning process. In RL one’s goal is to learn a policy $\Pi : S \times A \rightarrow [0, 1]$ which returns a probability distribution over actions in A to take at any given state in order to maximize the expected, future, discounted reward.

Differentiable Decision Trees (DDT) – Initially introduced by [Suárez and Lutsko, 1999] for classification and regression and extended to RL by Silva and Gombolay [2020], DDTs are fuzzy decision trees which can be optimized through backpropagation. In this paper, we leverage the RL version of DDTs developed by Silva and Gombolay [2020], i.e ProLoNets. In a ProLoNet, each decision node of the tree, D_n , contains a set of weights, $\vec{p}_n \in P$, and comparator values, $c_n \in C$, which are passed through a sigmoid, σ , approximating reasoning of a classic decision tree (Eq. 1).

$$D_n = \sigma[\alpha(\vec{p}_n^T * \vec{X} - c_n)] \quad (1)$$

Every leaf node $\vec{l}_i \in L$ contains probabilities for each output action $a \in A$ as well as a path from the root of the tree to its position. The action probabilities in \vec{l}_i are then weighted by the path probability of reaching \vec{l}_i , which is determined by the output of all decision nodes in the path. The weighted probabilities from all leaves are summed to produce the final output, which is a distribution across all actions, serving as an agent’s policy.

Seq2Tree – Recurrent Neural Networks (RNNs) [Hochreiter and Schmidhuber, 1997] are well-suited to tasks that require learning causal dependencies. An important recurrent model relevant to this paper is the sequence to tree (Seq2Tree) architecture presented by Dong and Lapata [2016]. This architecture was developed for translating natural language into logical meaning representations. The creators of Seq2Tree (S2T) expand the Seq2Seq [Sutskever et al., 2014] architecture to incorporate hierarchical output representations using a tree decoder. Each output token of the decoder is classified as a terminal or non-terminal token. When the model predicts a non-terminal token, the RNN cell is re-conditioned on the non-terminal token as well as the current hidden vector h . For example, if the model predicts a non-terminal y_4 after three tokens $y_1 \dots y_3$, the model is then reconditioned on y_4 to generate a new sequence beginning $y_5(0) \dots y_5(n)$ indicating a new branch of the tree beginning at $y_5(0)$. The network is trained to maximize $p(y_1, y_2, y_3, y_4 | h)p(y_5(0) \dots y_5(n) | h, y_{i < 5})$.

4 Method

Translating natural language to a lexical decision tree is a sequential decision making task in which each node is dependent on information from only its parents, rather than from all prior predictions (as is typically the case in standard

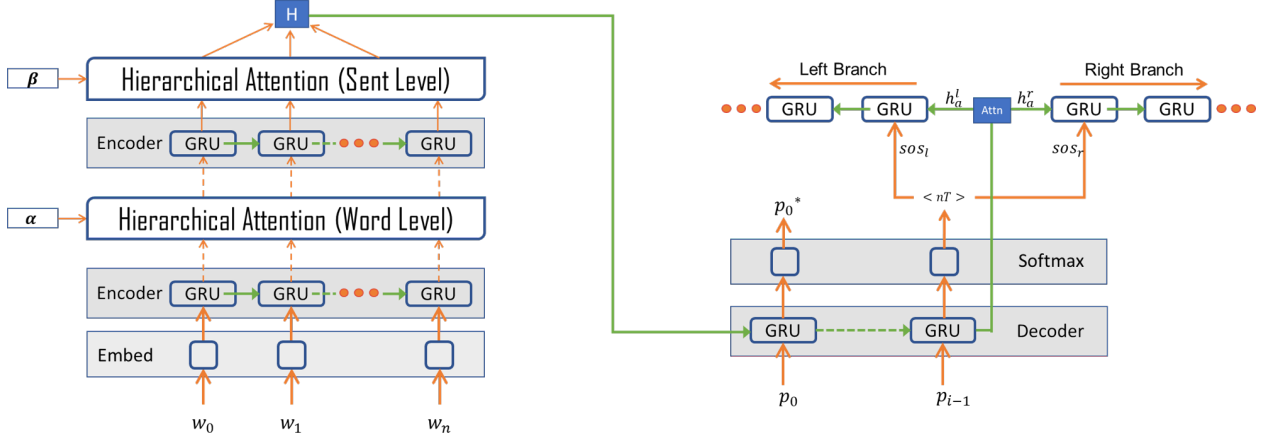

Figure 2: This figure depicts our HAN2Tree architecture. Each sentence consists of n words $[w_0 \dots w_n]$ is passed as an input to a HAN encoder. An embedding (H) is created for the input after applying both word-level and sentence level attention which is used as an input to a two-pronged tree decoder to generate decision trees. New left and right branches of the decoder are created every time the decoder predicts a non-terminal token ($\langle nT \rangle$)

RNNs). Generating accurate decision trees requires isolating the prior information relevant to each branch of the tree out of the entire set of instructions. The policy descriptions are lengthy and unstructured, making it difficult to isolate relevant information to each branch of the tree.

To this end, we propose an architecture that leverages the Hierarchical Attention Network [Yang et al., 2016] as an encoder and extends S2T as a decoder. The hierarchical self-attention mechanism enables our methodology to model contextually relevant details in an unstructured natural language instruction for synthesizing and discrete decision tree-based policies. Our tree parser is domain-agnostic and can be used to generate trees of any size/shape provided sufficient training examples.

The Hierarchical Attention Encoder (HAN) consists of two RNN layers. The first layer takes in embeddings, w_{it} , for each word t in the i^{th} sentence in the input and uses self-attention to create a sentence embedding, s_i (Eq. 2-4).

$$h_{it} = GRU(h_{it-1}, w_{i:k < t}) \quad (2)$$

$$\alpha_{it} = \frac{\exp(h_{it}^\top W_w)}{\sum_j \exp(h_{ij}^\top W_w)} \quad (3)$$

$$s_i = \sum_j \alpha_{jt} h_{ij} \quad (4)$$

In these equations, h_{it} is the hidden state corresponding to word t for sentence i . W_w represents a weight vector for the self-attention layer and α_{it} corresponds to the importance weight for the hidden state of word t in sentence i . The embedding for sentence i is calculated by a weighted combination of the hidden states for all the words in the sentence. The second layer of RNNs creates a hidden vector by applying self-attention on the sentence embeddings generated by the first layer of the encoder.

$$u_i = GRU(u_{i-1}, s_{j < i}) \quad (5)$$

$$\beta_i = \frac{\exp(u_i^\top W_s)}{\sum_j \exp(u_j^\top W_s)} \quad (6)$$

$$h_e = \sum_j \beta_j u_j \quad (7)$$

In eq 5 - 7, the HAN encoder re-applies hierarchical attention(Eq. 2-4) on sentence embeddings to produce a new vector h_e which is the final hidden vector for the entire policy description. This vector then becomes the input to the tree decoder. Unlike in the work presented by Dong and Lapata [2016], in our tree decoder, each non-terminal prediction creates two separate branches to facilitate an architecture similar to that of a decision tree. We also supplement each recurrent unit in the decoder with attention [Zhang et al., 2017].

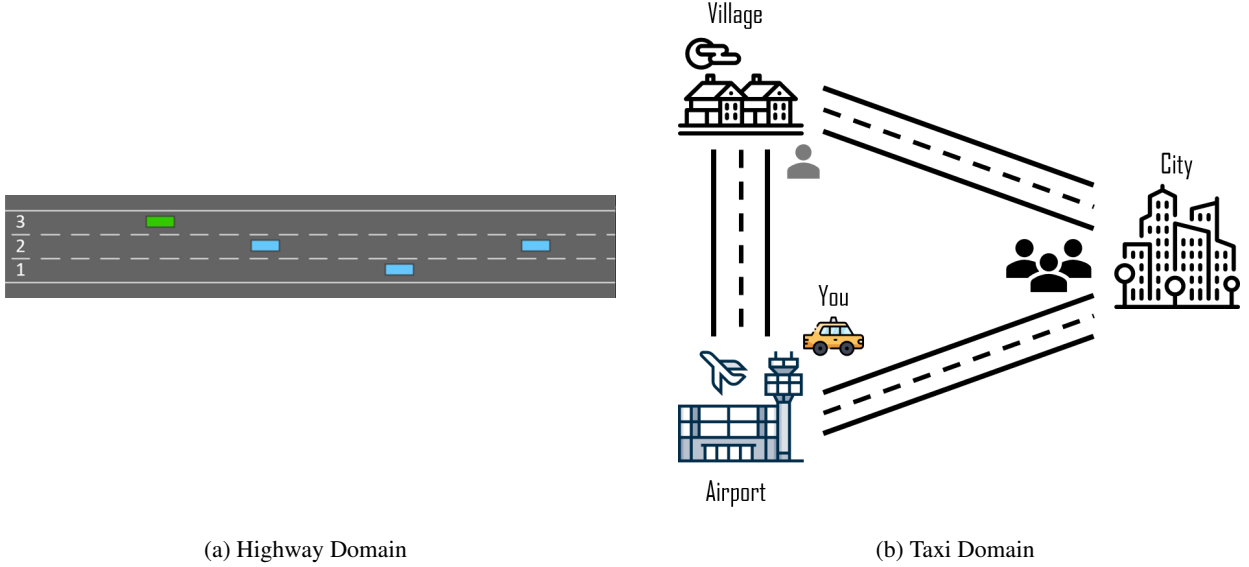

Figure 3: Depictions of learning environments used in this paper.

When a non-terminal is predicted by an RNN, two new branches of RNNs are reconditioned as shown in Eq. 8-13.

$$\rho_i^l = \frac{\exp(\tanh(W_{attn}^l[u_i^\top; h_p]))}{\sum_j \exp(\tanh(W_{attn}^l[u_j^\top; h_p]))} \quad (8)$$

$$h_a^l = \sum_j \rho_i^l u_j \quad (9)$$

$$\rho_i^r = \frac{\exp(\tanh(W_{attn}^r[u_i^\top; h_p]))}{\sum_j \exp(\tanh(W_{attn}^r[u_j^\top; h_p]))} \quad (10)$$

$$h_a^r = \sum_j \rho_i^r u_j \quad (11)$$

$$h_l = GRU(h_a^l, sos_l) \quad (12)$$

$$h_r = GRU(h_a^r, sos_r) \quad (13)$$

In these equations, sos_l and sos_r are the start tokens for left and right branches, and h_p is to the hidden vector outputted by the parent RNN. This new HAN2Tree framework (see figure 2), to the best of our knowledge is the first methodology to generate decision trees from natural language.

We define the target language as the set of all possible decision nodes or leaves for a given domain. For our experimental domains (Section 5), we specify a dictionary of all possible predicates a priori. Translating from natural language into a structured decision tree of these predicates, we are able to encode the human’s policy into a ProLoNet (Section 3) using the decision tree structure and parameters. This intermediate decision tree representation also provides an intelligible modality for a user to visualize their specified policy, should they want to modify or re-specify the policy prior to optimization (see figure 4). We can then apply proximal policy optimization [Schulman et al., 2017] to this model to improve upon the initial policy specification. Using this approach to translate from natural language into neural network structure and parameters, we provide a crucial extension to prior work Silva and Gombolay [2020] which is both easier to use and more generally applicable.

5 Experimental Domains

Taxi Domain – We use a variant of the Taxi domain Dietterich [2000] as our first domain. Our modified domain consists of three locations: the airport, village and city (see figure 3). Both the city and the village are equidistant from the airport. The taxi driver is rewarded for each passenger they transport to the airport. The city always has a passenger waiting to be picked up, while there may be a 60-minute wait time to acquire passengers from the village. Conversely, the driver may also encounter up to 60 minutes of traffic going into the city, whereas there is no traffic while driving

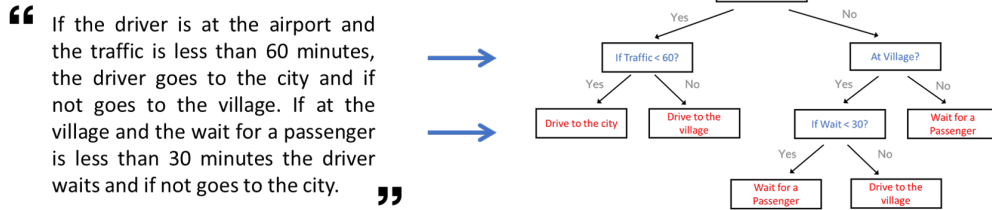

Figure 4: An example of a lexical decision tree generated from an instruction in our held-out dataset.

towards the village. The domain’s state space consists of the taxi’s location, the traffic towards the city, and the village wait time. Actions consists of driving to a destination or waiting for a passenger.

Highway Domain – The highway domain was initially proposed by Abbeel and Ng [2004] for apprenticeship learning. In our version of this domain, the highway consists of three lanes, with the traffic all moving in the same direction, as shown in figure 3a Leurent [2018]. The positions of all cars on the highway are initialized randomly except the agent’s car which always starts behind all other cars. The state space is comprised of the $[x, y, \dot{x}, \dot{y}]$ vectors for the 4—closest cars to the agent. (x, y) corresponds to the position of the car and (\dot{x}, \dot{y}) represents the velocity of the car in the x and y directions. The action space consists of five actions; move left, move right, speed up, slow down, and maintain current speed. In this domain, the agent is rewarded for safely traversing the highway at a high velocity. However the agent is provided a negative reward if they crash.

6 Data Collection

To the best of our knowledge, there is no pre-existing dataset consisting of natural language instructions mapped to corresponding decision trees. We utilized Mechanical Turk to crowdsource a novel supervised learning dataset for policy specification. The objectives of our data collection endeavor were to: 1) Collect free-form natural language that accurately describes policies that lead to plausible behavior within the domain; 2) Facilitate a varied set of policies specified to ensure that our model is not biased towards specific strategies.

6.1 Data Collection Methodology

To collect the requisite data, we built a Qualtrics survey [Qualtrics, 2019]. All participants were recruited from Mechanical Turk and were between the ages of 18-65. Participants did not interact with the domain themselves, rather users received pictures of the domain (as per figure 3) as well as a description of the environment. Our data collection interface consisted of a binary tree of depth 4 consisting of 15 empty text-fields. Participants were asked to fill up the tree using a limited collection of predicates to specify their desired policy. After creating their trees, participants were instructed to submit a natural language version of the policy they just specified in tree form.

Each participant was asked to provide one tree and its corresponding language description. Participants were compensated up to \$2.5 based on a pre-specified, prorated payment structure. Collecting the language responses after trees was a deliberate design choice in order to elicit language descriptions that were focused and relevant to the participant-specified tree. However, the descriptions provided by Turkers were entirely unstructured. Participants were not provided any additional prompts or templates from which to build their responses, thus ensuring that our methodology can be replicated across more complex domains.

Each submitted response was carefully evaluated according to a pre-defined rubric, and only the data points in which the instructions accurately described the policy specification and correctly correlated with the high-level strategy were included in our final dataset. Our study concluded with 200 such policy specifications and instructions for each domain.

6.2 Data Preparation

Prior to training, we performed pre-processing steps on the input text. We first standardized the data by removing stop-words, punctuation, and converting all characters to lower-case. We augmented our dataset by performing synonym replacement and random synonym insertion using word-sense disambiguation. After augmenting our available tree descriptions, our entire dataset totalled 978 and 991 examples for the Taxi and Highway domains, respectively. Finally we applied a 70/30 split to create our training and validation sets. Our source and target vocabulary size amounted to

	Taxi	Highway
Seq2Seq	90.82% (0.017)	91.81% (0.023)
Seq2Tree	92.28% (0.023)	93.60% (0.020)
Seq2Tree (BERT Enhanced)	94.33% (0.009)	94.81% (0.008)
HAN2Tree (Ours)	95.93% (.014)	97.49% (0.038)

Table 1: The mean (standard deviation) accuracy across 5-fold cross-validation on held-out dataset.

Dataset Statistics							
Statistic	Geo880	ATIS	Scholar	JOBS	IFTTT	Taxi	Highway
Avg NL Length	7.56	10.97	6.69	9.8	6.95	85.47	102.13
NL Vocab Size	151	808	303	–	–	812	717

Table 2: Comparison of other datasets used for semantic parsing with respect to the two datasets we collected.

812 and 20 for the Taxi Domain and 717 and 20 for the highway domain. The average token length policy descriptions in our dataset were 85.47 and 102.13 for the Taxi and Highway domain respectively.

Remark 1 – (Dataset Novelty) *Prior work focused on translating natural language into a structured representation, i.e. a tree, has often dealt with semantic parsing into a logical form or SQL query [Dong and Lapata, 2016, Jia and Liang, 2016, Iyer et al., 2017]. However, these methods deal with datasets whose natural language (NL) sequences are almost 10x smaller than that of our datasets as the language inputs in our sequence describe the entire policy rather than a single command (see Table 2). Crucially, the size of our policy descriptions allows us to conduct “document-level” experiments on our data. Due to the scale of policies in real-world domains, enabling “document-level” analysis is of paramount importance for effectively specifying entire robot policies. To the best of our knowledge, no pre-existing dataset is comparable to ours both in terms of size of samples and formats of input and output data.*

7 Results

In this section, our goal is to empirically validate the advantages of our approach to warm starting policy optimization with natural language policy initialization. Our evaluation consists of two sets of experiments. First, Section 7.1 presents results showing that our HAN2Tree approach can generate lexical decision trees from language with a near perfect accuracy, and compares our approach to relevant baselines. Second, section 7.2 demonstrated that we can bootstrap natural language policy initialization to outperform reinforcement learning baselines. Combined, these results demonstrate the power of our human-centered approach to policy specification and optimization.

7.1 Policy Synthesis from Language

To evaluate our method for policy synthesis from natural language, we employ three baselines,

1. Seq2Seq: We trained a Seq2Seq network with attention [Bahdanau et al., 2014] to generate flattened representations of the trees in our dataset. Trees are flattened using a depth-first traversal.
2. Seq2Tree: Our second baseline is an extension of the architecture presented in Dong and Lapata [2016], where we employ a tree decoder as presented in Section 4.1.
3. Seq2Tree (BERT enhanced): This baseline incorporated pretrained BERT embeddings into the aforementioned Seq2Tree baseline.
4. HAN2Tree: Our approach as presented in Section 4.1.

We include a “BERT enhanced” baseline to leverage large-scale pretraining for our word embeddings, allowing us to see what benefits may be gained by warm-starting our approach with this prior knowledge. Rather than using the pretrained BERT model directly as the encoder, we instead chose to leverage BERT as a feature encoder as shown successfully in prior work [Zhu et al., 2020, Peters et al., 2018]. We incorporate BERT embeddings into our model according to Eq. 14.

$$w_i = \tanh(W_{emb} [e_i^T; \alpha \times (W_{bert} BERT(i))]) \quad (14)$$

$BERT(i)$ represents the 786-dimensional BERT embedding for word i . In the BERT-enhanced baseline, this embedding is first passed through a linear layer for the purpose of dimensionality reduction, and is subsequently used to create a combined new word embedding (w_i) through a weighted concatenation with the embedding learnt by the RNN, e_i . The α term represents a weighting parameter for the BERT feature vector in computing the final combined embedding.

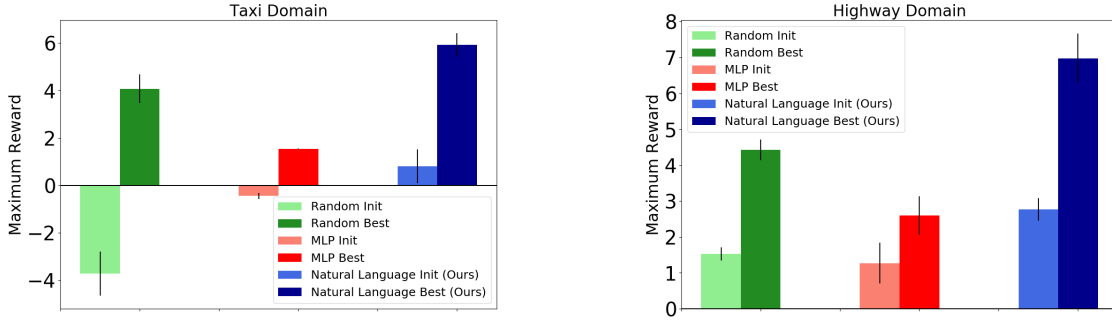

Figure 5: This figure depicts the initial and maximum rolling rewards learned for each method in both domains.

Input tokenization was word-based while tokenization on the output/tree side was predicate based, i.e. each question/answer within the tree was one token. All four translation models were comprised of GRU cells with a hidden size of 56. The embedding layers for the encoder and the decoder had an embedding size of 120 and 20 respectively, and all embedding layers are trained from scratch. Each baseline was trained with an Adam optimizer [Kingma and Ba, 2014].

We report the 5-fold cross validation accuracy for each of our baselines (Table 1). Accuracy was measured as the percentage of generated trees that were a 100% match with the target tree. In both domains, our model is able to outperform all baselines with respect to the validation set accuracy. Our best-performing model in the highway domain achieved a mean accuracy of 97.47% with a standard deviation of 0.038. The accuracy of our approach is 4% and 6% more than the mean accuracies for the Seq2Tree and Seq2Seq approaches respectively. A similar trend is observable for the taxi domain. An example of a tree generated from language using our approach is shown in figure 4.

Our HAN2Tree approach also outperforms the BERT enhanced baseline for both domains, showing that our model is able to outperform baselines even when they are enhanced with features from large-scale pretrained language-models. We do acknowledge that as the size of the dataset increases, the benefits of using a BERT enhanced structure will be more evident and may even lead to comparable results to our approach. We leave exploration of this matter to future work.

Given our success in natural language specification of a tree-based policy, we consequently tested whether these generated decision trees can warm-start reinforcement learning. While prior work Silva and Gombolay [2020] has shown that DDTs can warm-start RL, we uniquely achieve this effect starting from natural language specifications of non-experts.

7.2 Policy Specification through RL

To evaluate downstream performance of a policy initialized through Natural Language, we employ these baselines:

1. NL ProLoNet: ProLoNet initialized with the policy generated from natural language.
2. MLP (PPO): A multi-layer perceptron (MLP) trained using proximal policy optimization.
3. Random ProLoNet: A randomly initialized ProLoNet.

To maintain consistency with the NL ProLoNet, the Random ProLoNet is initialized with 16 leaves. We assess our performance in each of the two domains specified above. All agents are trained with a proximal policy optimization (PPO) procedure [Schulman et al., 2017].

Figure 5 depicts the result of reinforcement learning policy learning on both domains over five runs of 5000 and 2000 episodes for the Taxi and Highway domains, respectively. In these graphs, we compare the performance of each RL agent within both domains by computing the maximum average rolling reward, calculated across runs. This experiment allows us to individually compare the best performing model for each baseline over the course of training. Each baseline in the bar graph consists of two columns; the first column is the average reward within the first 200 and 50 episodes of training for the Taxi and Highway domains, respectively, and the second column depicts the maximum average rolling reward over the course of training using the same window of episodes. This experiment provides a clear depiction of the improvement of each model across training as well as the benefits of natural language initialization of policies.

The results for the NL baseline have been computed by generating trees from ten randomly selected natural language instructions and using them to initialize a ProLoNet. The final values shown in the graph for this baseline is an

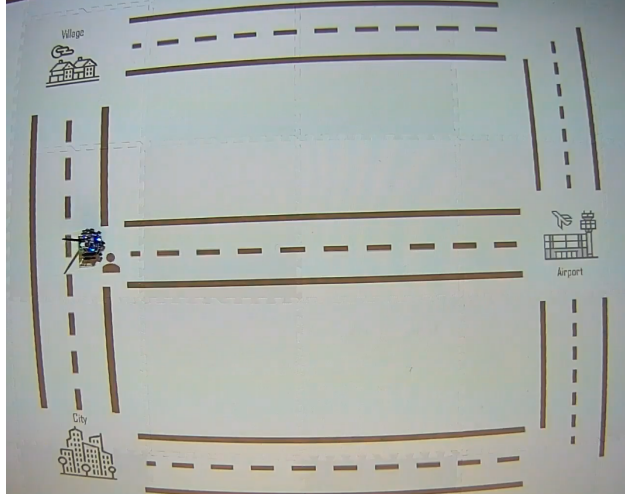

Figure 6: Robot taking passenger back to the airport using policy initialized through natural language.

average across all ten trees. For the Taxi domain, a Wilcoxon signed rank test shows that ProLoNets initialized through natural language instructions (Median = 7.225, IQR = 0.57) can be trained to achieve significantly higher reward when compared to the best performing versions of the MLP (Median = 1.57, IQR = 0.23) and Random baselines (Median = 6.57, IQR = 0.71) with, $p < 0.0001$ and $p < 0.001$ respectively. Results in the highway domain were reflective of those in the taxi domain. Specifically, ProLoNets initialized through language are significantly superior to the MLP and Random baselines as well as its own initial specification ($p < 0.01$, $p < 0.001$ respectively).

These results support our hypothesis that high translation accuracies, for both domains, lead to policies initialized with RL outperforming comparable RL approaches without any language initialization ($p < 0.01$). As such, by successfully initializing ProLoNets through natural language, we facilitate the first such methodology where humans can program their desired robot policies through free-form natural language, and following optimization, infer the robot’s behavior through an intelligible architecture.

An added benefit of leveraging the ProLoNets architecture is that we could discretize these networks to generate a discrete interpretation of the optimized policy [Silva et al., 2020]. With an exact, interpretable decision tree, we would then be able to close the policy-specification loop for a user, allowing them to visualize the final version of the robot policy which they specified. We aim to explore closing this loop by discretizing the trees we learn in future work.

8 Robot Demonstration

To demonstrate that we can produce stable navigation policies using natural language instructions, we deployed policies initialized through natural language on a robot within the Robotarium platform [Pickem et al., 2017]. This testbed provides access to a swarm of robots which can be controlled to perform a fully observable navigation task. Using this system, we demonstrate a working example of a robot using our policy within the taxi domain (see figure 6). The robot follows the learned policy and transports the passenger to the airport as specified by the natural language command.

9 Limitations/Future Work

In this work, we assumed that asking participants to describe policies as natural language would be preferable to directly specifying policies as decision trees through a graphical user interface. While this assumption is supported by prior work [Lipton, 2018], it would be worthwhile to see if this assumption bears out in practice, via a user-study.

There are also a few important limitations due to the size and scope of our dataset. In our data-collection protocol, participants were limited to trees of depth four to reduce their cognitive load while taking our study. Based on analysis of collected policies in pilot studies, trees of depth four were ascertained to be the deepest trees needed to describe the majority of behaviors possible in the two domains we tested on. However trees of depth four may be insufficient for other domains. In such domains, one would have to restructure the data-collection task to collect any variable size decision trees, but the approach presented in this paper would still be applicable.

Secondly, our dataset contained descriptions of 200 unique policies for each domain, which we augmented through natural language augmentation techniques. Even though this was sufficient for our approach to achieve an accuracy of 96%, approaches trained on a dataset of this size will find it difficult to fully leverage the benefits of pretrained language modeling. Our approach outperforms a BERT-enhanced baseline, as shown in our results section; however, further testing is required to ascertain the applicability of pretrained language modeling for policy specification from language tasks.

In section 7.2, we discussed work presented in Silva et al. [2020] that presented an approach to distill an optimized DDT into a discrete policy. An important avenue of future work would be to apply this technique on learned DDTs that were initialized through language. This post-optimization discretization would allow us a facility to compare the initial descriptions with the final learned policy, as well as study how the presence of such policy interpretations affects an individual’s interactions with a robot.

10 Conclusion

In this paper, we developed a human-centered, interpretable framework for policy specification through natural language followed by policy improvement via reinforcement learning. Furthermore, we showcase a data collection methodology that can be used to collect decision trees, of any size, and the natural language descriptions corresponding to these trees for any given domain. Utilizing this protocol, we crowd-sourced the largest known corpus mapping unstructured, free-form natural language instructions to lexical decision trees. Our novel machine learning architecture, called HAN2Tree, was capable of generating lexical decision trees from language with a 96% accuracy. Finally, we demonstrate the effectiveness of using natural language initializations by showing that our approach significantly outperforms relevant baselines without natural language initialization ($p < 0.001$).

References

- Pieter Abbeel and Andrew Y Ng. Apprenticeship learning via inverse reinforcement learning. In *Proceedings of the twenty-first international conference on Machine learning*, page 1. ACM, 2004.
- Ashley D Edwards, Himanshu Sahni, Yannick Schroecker, and Charles L Isbell. Imitating latent policies from observation. *arXiv preprint arXiv:1805.07914*, 2018.
- Ching-An Cheng, Xinyan Yan, Nolan Wagener, and Byron Boots. Fast policy learning through imitation and reinforcement. *arXiv preprint arXiv:1805.10413*, 2018.
- Ashvin Nair, Bob McGrew, Marcin Andrychowicz, Wojciech Zaremba, and Pieter Abbeel. Overcoming exploration in reinforcement learning with demonstrations. In *2018 IEEE International Conference on Robotics and Automation (ICRA)*, pages 6292–6299. IEEE, 2018.
- Daniel S Weld and Gagan Bansal. The challenge of crafting intelligible intelligence. *Communications of the ACM*, 62(6):70–79, 2019.
- M Asif Rana, Daphne Chen, Jacob Williams, Vivian Chu, S Reza Ahmadzadeh, and Sonia Chernova. Benchmark for skill learning from demonstration: Impact of user experience, task complexity, and start configuration on performance. In *2020 IEEE International Conference on Robotics and Automation (ICRA)*, pages 7561–7567. IEEE, 2020.
- Saleema Amershi, Maya Cakmak, William Bradley Knox, and Todd Kulesza. Power to the people: The role of humans in interactive machine learning. *Ai Magazine*, 35(4):105–120, 2014.
- Nakul Gopalan, Dilip Arumugam, Lawson Wong, and Stefanie Tellex. Sequence-to-Sequence Language Grounding of Non-Markovian Task Specifications. In *Proceedings of Robotics: Science and Systems*, Pittsburgh, Pennsylvania, June 2018. doi: 10.15607/RSS.2018.XIV.067.
- Stefanie Tellex, Nakul Gopalan, Hadas Kress-Gazit, and Cynthia Matuszek. *Annual Review of Control, Robotics, and Autonomous Systems*, 3:25–55, 2020.
- Valts Blukis, Yannick Terme, Eyvind Niklasson, Ross A Knepper, and Yoav Artzi. Learning to map natural language instructions to physical quadcopter control using simulated flight. *arXiv preprint arXiv:1910.09664*, 2019.
- Dipendra Misra, Andrew Bennett, Valts Blukis, Eyvind Niklasson, Max Shatkhin, and Yoav Artzi. Mapping instructions to actions in 3d environments with visual goal prediction. *arXiv preprint arXiv:1809.00786*, 2018.
- Jacob Andreas, Dan Klein, and Sergey Levine. Modular multitask reinforcement learning with policy sketches. In *Proceedings of the 34th International Conference on Machine Learning-Volume 70*, pages 166–175. JMLR. org, 2017.

- Upol Ehsan and Mark O Riedl. Human-centered explainable ai: Towards a reflective sociotechnical approach. *arXiv preprint arXiv:2002.01092*, 2020.
- Guangliang Li, Randy Gomez, Keisuke Nakamura, and Bo He. Human-centered reinforcement learning: a survey. *IEEE Transactions on Human-Machine Systems*, 49(4):337–349, 2019.
- Andrew Silva and Matthew Gombolay. Neural-encoding human experts’ domain knowledge to warm start reinforcement learning, 2020.
- Andrew Silva, Matthew Gombolay, Taylor Killian, Ivan Jimenez, and Sung-Hyun Son. Optimization methods for interpretable differentiable decision trees applied to reinforcement learning. volume 108 of *Proceedings of Machine Learning Research*, pages 1855–1865, Online, 26–28 Aug 2020. PMLR. URL <http://proceedings.mlr.press/v108/silva20a.html>.
- Hadas Kress-Gazit and Georgios E Fainekos. Translating structured English to robot controllers. *Advanced Robotics*, 22:1343–1359, 2008.
- S. Tellex, T. Kollar, S. Dickerson, M.R. Walter, A. Banerjee, S. Teller, and N. Roy. Understanding natural language commands for robotic navigation and mobile manipulation. In *Proceedings of the National Conference on Artificial Intelligence*, 2011.
- Cynthia Matuszek, Evan Herbst, Luke Zettlemoyer, and Dieter Fox. Learning to parse natural language commands to a robot control system. In *Experimental Robotics*, pages 403–415. Springer International Publishing, 2013.
- Yoav Artzi and Luke Zettlemoyer. Weakly supervised learning of semantic parsers for mapping instructions to actions. *Transactions of the Association for Computational Linguistics*, 1:49–62, 2013.
- Jesse Thomason, Aishwarya Padmakumar, Jivko Sinapov, Nick Walker, Yuqian Jiang, Harel Yedidsion, Justin Hart, Peter Stone, and Raymond J Mooney. Improving grounded natural language understanding through human-robot dialog. In *2019 International Conference on Robotics and Automation (ICRA)*, pages 6934–6941. IEEE, 2019.
- Dilip Arumugam, Siddharth Karamcheti, Nakul Gopalan, Lawson L. S. Wong, and Stefanie Tellex. Accurately and efficiently interpreting human-robot instructions of varying granularities. In *Robotics: Science and Systems XIII, Massachusetts Institute of Technology, Cambridge, Massachusetts, USA, July 12-16, 2017*, 2017. doi: 10.15607/RSS.2017.XIII.056. URL <http://www.roboticsproceedings.org/rss13/p56.html>.
- Karl Moritz Hermann, Felix Hill, Simon Green, Fumin Wang, Ryan Faulkner, Hubert Soyer, David Szepesvari, Wojciech Marian Czarnecki, Max Jaderberg, Denis Teplyashin, Marcus Wainwright, Chris Apps, Demis Hassabis, and Phil Blunsom. Grounded language learning in a simulated 3d world. *CoRR*, abs/1706.06551, 2017.
- Dzmitry Bahdanau, Felix Hill, Jan Leike, Edward Hughes, Arian Hosseini, Pushmeet Kohli, and Edward Grefenstette. Learning to understand goal specifications by modelling reward. *arXiv preprint arXiv:1806.01946*, 2018.
- Valts Blukis, Nataly Brukhim, Andrew Bennett, Ross A. Knepper, and Yoav Artzi. Following high-level navigation instructions on a simulated quadcopter with imitation learning. In *Proceedings of the Robotics: Science and Systems Conference*, 2018.
- Finale Doshi-Velez and Been Kim. Towards a rigorous science of interpretable machine learning. *arXiv preprint arXiv:1702.08608*, 2017.
- Karen Simonyan, Andrea Vedaldi, and Andrew Zisserman. Deep inside convolutional networks: Visualising image classification models and saliency maps. *arXiv preprint arXiv:1312.6034*, 2013.
- Ramprasaath R Selvaraju, Michael Cogswell, Abhishek Das, Ramakrishna Vedantam, Devi Parikh, and Dhruv Batra. Grad-cam: Visual explanations from deep networks via gradient-based localization. In *Proceedings of the IEEE International Conference on Computer Vision*, pages 618–626, 2017.
- Jason Yosinski, Jeff Clune, Anh Nguyen, Thomas Fuchs, and Hod Lipson. Understanding neural networks through deep visualization. *arXiv preprint arXiv:1506.06579*, 2015.
- Alex Mott, Daniel Zoran, Mike Chrzanowski, Daan Wierstra, and Danilo J Rezende. Towards interpretable reinforcement learning using attention augmented agents. *arXiv preprint arXiv:1906.02500*, 2019.
- Tom Zahavy, Nir Ben-Zrihem, and Shie Mannor. Graying the black box: Understanding dqns. In *International Conference on Machine Learning*, pages 1899–1908, 2016.
- Grégoire Montavon, Wojciech Samek, and Klaus-Robert Müller. Methods for interpreting and understanding deep neural networks. *Digital Signal Processing*, 73:1–15, 2018.
- Christian Szegedy, Wojciech Zaremba, Ilya Sutskever, Joan Bruna, Dumitru Erhan, Ian Goodfellow, and Rob Fergus. Intriguing properties of neural networks. *arXiv preprint arXiv:1312.6199*, 2013.

- Kelli D Humbird, J Luc Peterson, and Ryan G McClarren. Deep neural network initialization with decision trees. *IEEE transactions on neural networks and learning systems*, 30(5):1286–1295, 2018.
- Zachary C Lipton. The mythos of model interpretability. *Queue*, 16(3):31–57, 2018.
- Alberto Suárez and James F Lutsko. Globally optimal fuzzy decision trees for classification and regression. *IEEE Transactions on Pattern Analysis and Machine Intelligence*, 21(12):1297–1311, 1999.
- Sepp Hochreiter and Jürgen Schmidhuber. Long short-term memory. *Neural computation*, 9(8):1735–1780, 1997.
- Li Dong and Mirella Lapata. Language to logical form with neural attention. *arXiv preprint arXiv:1601.01280*, 2016.
- Ilya Sutskever, Oriol Vinyals, and Quoc V Le. Sequence to sequence learning with neural networks. In *Advances in neural information processing systems*, pages 3104–3112, 2014.
- Zichao Yang, Diyi Yang, Chris Dyer, Xiaodong He, Alex Smola, and Eduard Hovy. Hierarchical attention networks for document classification. In *Proceedings of the 2016 conference of the North American chapter of the association for computational linguistics: human language technologies*, pages 1480–1489, 2016.
- Jianshu Zhang, Jun Du, and Lirong Dai. A gru-based encoder-decoder approach with attention for online handwritten mathematical expression recognition. In *2017 14th IAPR International Conference on Document Analysis and Recognition (ICDAR)*, volume 1, pages 902–907. IEEE, 2017.
- John Schulman, Filip Wolski, Prafulla Dhariwal, Alec Radford, and Oleg Klimov. Proximal policy optimization algorithms. *arXiv preprint arXiv:1707.06347*, 2017.
- Thomas G Dietterich. Hierarchical reinforcement learning with the maxq value function decomposition. *Journal of artificial intelligence research*, 13:227–303, 2000.
- Edouard Leurent. An environment for autonomous driving decision-making. <https://github.com/eleurent/highway-env>, 2018.
- Qualtrics. Qualtrics. <https://www.qualtrics.com>, 2019.
- Robin Jia and Percy Liang. Data recombination for neural semantic parsing. *arXiv preprint arXiv:1606.03622*, 2016.
- Srinivasan Iyer, Ioannis Konstas, Alvin Cheung, Jayant Krishnamurthy, and Luke Zettlemoyer. Learning a neural semantic parser from user feedback. *arXiv preprint arXiv:1704.08760*, 2017.
- Dzmitry Bahdanau, Kyunghyun Cho, and Yoshua Bengio. Neural machine translation by jointly learning to align and translate. *arXiv preprint arXiv:1409.0473*, 2014.
- Jinhua Zhu, Yingce Xia, Lijun Wu, Di He, Tao Qin, Wengang Zhou, Houqiang Li, and Tie-Yan Liu. Incorporating bert into neural machine translation. *arXiv preprint arXiv:2002.06823*, 2020.
- Matthew E Peters, Mark Neumann, Mohit Iyyer, Matt Gardner, Christopher Clark, Kenton Lee, and Luke Zettlemoyer. Deep contextualized word representations. *arXiv preprint arXiv:1802.05365*, 2018.
- Diederik P Kingma and Jimmy Ba. Adam: A method for stochastic optimization. *arXiv preprint arXiv:1412.6980*, 2014.
- Daniel Pickem, Paul Glotfelter, Li Wang, Mark Mote, Aaron Ames, Eric Feron, and Magnus Egerstedt. The robotarium: A remotely accessible swarm robotics research testbed. In *2017 IEEE International Conference on Robotics and Automation (ICRA)*, pages 1699–1706. IEEE, 2017.