

Architectural Patterns for the Design of Federated Learning Systems

Sin Kit Lo^{a,b,*}, Qinghua Lu^{a,b}, Liming Zhu^{a,b}, Hye-young Paik^b, Xiwei Xu^{a,b} and Chen Wang^a

^aData61, CSIRO, Australia

^bUniversity of New South Wales, Australia

ARTICLE INFO

Keywords:

Federated Learning

Pattern

Software Architecture

Machine Learning

ABSTRACT

Federated learning has received fast-growing interests from academia and industry to tackle the challenges of data hunger and privacy in machine learning. A federated learning system can be viewed as a large-scale distributed system with different components and stakeholders as numerous client devices participate in federated learning. Designing a federated learning system requires software system design thinking apart from machine learning knowledge. Although much effort has been put into federated learning from the machine learning technique aspects, the software architecture design concerns in building federated learning systems have been largely ignored. Therefore, in this paper, we present a collection of architectural patterns to deal with the design challenges of federated learning systems. Architectural patterns present reusable solutions to a commonly occurring problem within a given context during software architecture design. The presented patterns are based on the results of a systematic literature review and include three client management patterns, four model management patterns, three model training patterns, and four model aggregation patterns. The patterns are associated to particular state transitions in a federated learning model lifecycle, serving as a guidance for effective use of the patterns in the design of federated learning systems.

1. Introduction

Federated Learning Overview

The exponential growth of data generated by IoT and mobile devices has accelerated the adoption of machine learning in many areas, such as natural language processing and computer vision. However, many machine learning systems suffer from insufficient data due to the increasing concerns on data privacy, e.g., restrictions on data sharing with external systems for machine learning purposes. Many of the recent privacy regulations, such as General Data Protection Regulation (GDPR) [31], stipulate a range of data protection measures and data privacy is now one of the most important ethical principles expected of machine learning systems [17].

To effectively address the data privacy challenge while still enabling effective data inferences by the data-hungry machine learning models, Google introduced the concept of federated learning [26] in 2016. Fig. 1 illustrates the overview of federated learning. There are three stakeholders in a federated learning system: (1) learning coordinator (i.e., system owner), (2) contributor client - data contributor & model trainer, and (3) user client - model user. Note that it is possible for a contributor client to be also a user client; and two types of nodes (i.e., hardware components): (1) central server, (2) client device. The federated learning process starts when a training task is created by the learning coordinator on the central server. The initial global model and the task script that includes the hyper-parameters are broad-

cast to the participating client devices. Model training is performed locally across a distributed network of client devices, without the centralised collection and storage of raw client data. The local training settings are configured by executing the task script. Each round of training usually takes one step of gradient descent on the current model using each client's local data. After each round, the model update (model parameters/gradient) is submitted by each participating client device to the central server. The central server collects all the model updates and performs model aggregation to form a new version of the global model. The new global model is re-distributed to the client devices for the next training round. This entire process iterates until the global model converges.

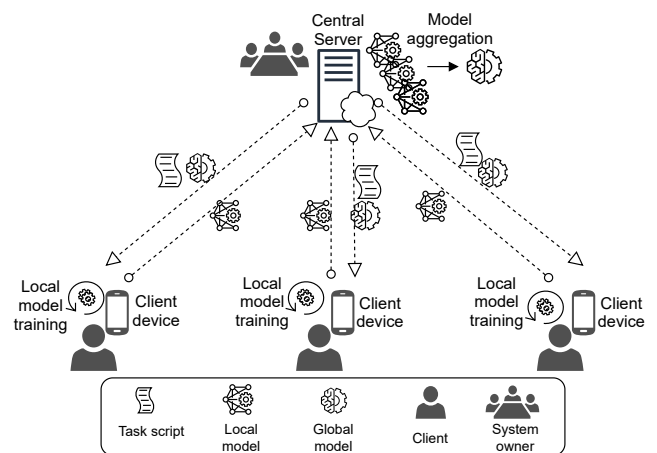

Figure 1: Federated Learning Overview.

Design Challenges

Compared to centralised machine learning, federated learning is more advantageous from the perspective of data pri-

✉ Kit.Lo@data61.csiro.au (S.K. Lo); Qinghua.Lu@data61.csiro.au (Q. Lu); liming.zhu@data61.csiro.au (L. Zhu); h.paik@unsw.edu.au (H. Paik); Xiwei.Xu@data61.csiro.au (X. Xu); Chen.Wang@data61.csiro.au (C. Wang)

ORCID(s): 0000-0002-9156-3225 (S.K. Lo); 0000-0002-7783-5183 (Q. Lu); 0000-0003-4425-7388 (H. Paik); 0000-0002-2273-1862 (X. Xu); 0000-0002-3119-4763 (C. Wang)

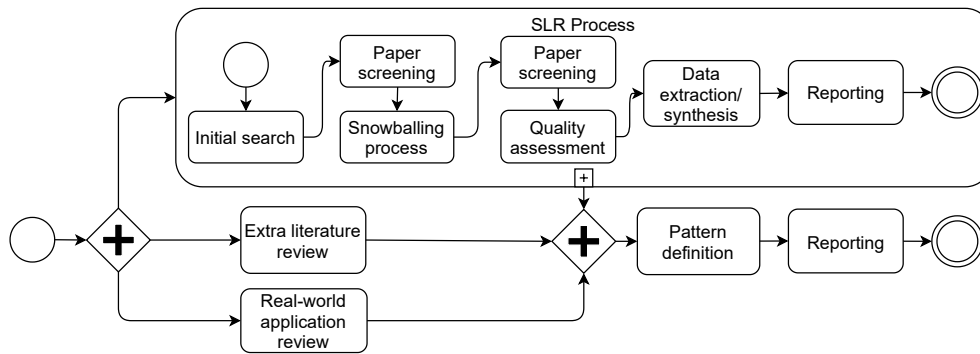

Figure 2: Pattern Collection Process.

vacy. However, a federated learning system, as a large-scale distributed system, presents more architectural design challenges [24], especially when dealing with the interactions between the central server and client devices and managing trade-offs of software quality attributes. The main design challenges are as follows.

- Global models might have low accuracy, and lack generality when client devices generate non-IID¹ data. Centralising and randomising the data is the approach adopted by conventional machine learning to deal with data heterogeneity but the inherent privacy-preserving nature of federated learning render such techniques inappropriate.
- To generate high-quality global models, multiple rounds of communication are required to exchange local model updates, which could incur high communication costs.
- Client devices have limited resources to perform the multiple rounds of model training and communications required by the system, which may affect the model quality.
- As numerous client devices participate in federated learning, it is challenging to govern the learning process and ensure model provenance and system reliability.

How to select appropriate designs to fulfill different software quality requirements and design constraints is non-trivial for such a complex distributed system. Although much effort has been put into federated learning from machine learning techniques side, there is a lack of work on the architectural design considerations of federated learning systems. A systematic guidance on architecture design of federated learning systems is required to better leverage the existing solutions and promote federated learning to enterprise-level adoption.

Research Contribution

In this paper, we present a collection of patterns for the design of federated learning systems. In software engineering, an architectural pattern is a reusable solution to a problem

¹Non-Identically and Independently Distribution (Non-IID): Highly-skewed and personalized data distribution that depends on the local environment and usage pattern. Both the size and the distribution of the local data sets typically vary heavily between different clients [29]

that occurs commonly within a given context in software design [3]. We collect and define the patterns based on the results of our previous systematic literature review on federated learning [24]. Our pattern collection includes three client management patterns, four model management patterns, three model training patterns, and four model aggregation patterns. We define the lifecycle of a model in a federated learning system and associate each identified pattern to a particular state transition in the lifecycle. The pattern collection provides a design solution pool for practitioners to choose from for a real-world federated learning system development.

The main contribution of this paper includes:

- The collection of architectural patterns provides a design solution pool for practitioners to select from for a real-world federated learning system development.
- The federated learning model lifecycle with architectural pattern annotations, which serves as a systematic guide for the practitioners during the design and development of a federated learning system.

Paper Structure

The remainder of the study is organised as follows. Section 2 introduces the research methodology. Section 3 provides an overview of the pattern collection, followed by the detailed discussions on each pattern in Section 4. Section 5 discusses the related work. Section 6 concludes the paper.

2. Methodology

Fig. 2 illustrates the federated learning pattern collection process. The patterns are collected based on the results of our previous systematic literature review (SLR) on federated learning [24], the additional literature review on machine learning (ML) and federated learning (FL), and the real-world applications. The SLR was performed according to Kitchenham's SLR guideline [18], and the number of final studied papers is 231. During the SLR, we developed a comprehensive mapping between FL challenges and approaches. Additionally, we reviewed 22 ML/FL papers published after the SLR search cut-off date (31st Jan 2020) and 22 real-world appli-

Table 1
Sources of Patterns.

Category	Pattern	SLR papers	ML/FL papers	Real-world applications
Client management patterns	Client registry	0	2	3
	Client selector	4	2	1
	Client cluster	2	2	2
Model management patterns	Message compressor	8	6	0
	Model co-versioning registry	0	0	4
	Model replacement trigger	0	1	3
	Deployment selector	0	0	3
Model training patterns	Multi-task model trainer	2	1	3
	Heterogeneous data handler	1	2	0
	Incentive registry	18	1	0
Model aggregation patterns	Asynchronous aggregator	4	1	0
	Decentralised aggregator	5	2	0
	Hierarchical aggregator	4	2	0
	Secure aggregator	31	0	3

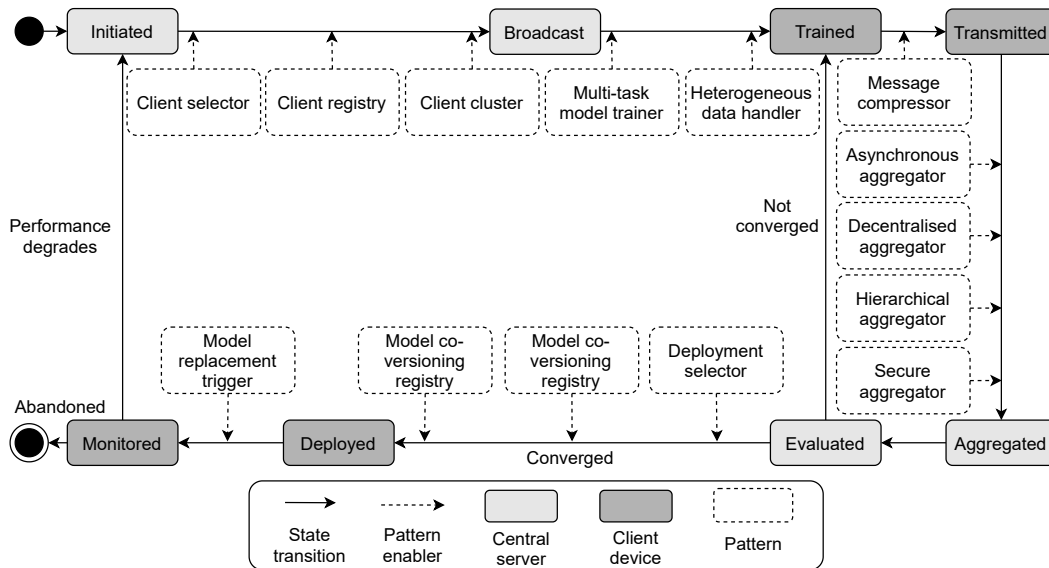

Figure 3: A Model's Lifecycle in Federated Learning.

cations. Table 1 shows a mapping between each pattern and the respective number of source papers or real-world applications. Twelve patterns were initially collected from SLR or additional literature review, while two patterns were identified through real-world applications.

3. Overview of Architectural Patterns

Fig. 3 illustrates the lifecycle of a model in a federated learning system. The lifecycle elaborates the entire process of a conventional FL system and in addition to the model training and update process mentioned in the introduction, the lifecycle covers the deployment of the completely trained global model to the client devices (i.e., model users) for data inference. The deployment process involves the communication between the central server and the client devices (model users that consist of existing model trainers and new model users). Each pattern annotated is associated with a particular state transition of the model in the lifecycle. All the patterns are related but mutually inclusive and independent of each

other.

We categorise the federated learning patterns as in Table 2 to provide an overview. There are four main groups: (1) client management patterns, (2) model management patterns, (3) model training patterns, and (4) model aggregation patterns.

Firstly, client management patterns describe the patterns that manage the client devices' information and their interaction with the central server. A *client registry* manages the information of all the participating client devices. *Client selector* selects client devices for a specific training task, while *client cluster* increases the model performance and training efficiency through grouping client devices based on the similarity on certain characteristics (e.g., available resources, data distribution).

Secondly, model management patterns include patterns that handle model transmission, deployment, and governance. A *message compressor* reduces the transmitted message size. A *model co-versioning registry* records all local model ver-

Table 2
Overview of architectural patterns for federated learning

Category	Name	Summary
Client management patterns	Client registry	Maintains the information of all the participating client devices for client management.
	Client selector	Actively selects the client devices for a certain round of training according to the predefined criteria to increase model performance and system efficiency.
	Client cluster	Groups the client devices (i.e. model trainers) based on their similarity on certain characteristics (e.g., available resources, data distribution, features, geolocation) to increase the model performance and training efficiency.
Model management patterns	Message compressor	Compresses and reduces the message data size before every round of model exchange to increase the communication efficiency.
	Model co-versioning registry	Stores and aligns the local models from each client with the corresponding global model versions for model provenance and model performance tracking.
	Model replacement trigger	Triggers model replacement when the degradation in model performance is detected.
	Deployment selector	Selects and matches the global models to suitable client devices to maximise the the global models' accuracy for different applications and tasks.
Model training patterns	Multi-task model trainer	Utilises data from separated but related models on local client devices to improve learning efficiency and model performance.
	Heterogeneous data handler	Solves the non-IID and skewed data distribution issues through data volume and data classes addition while maintaining the local data privacy.
	Incentive registry	Measures and records the performance and contributions of each client and provide incentives to motivate clients' participation.
Model aggregation patterns	Asynchronous aggregator	Performs aggregation asynchronously whenever a model update arrives without waiting for all the model updates every round to reduce aggregation latency.
	Decentralised aggregator	The removal of the central server from the system and decentralised its role to prevent single-point-of-failure and increase system reliability.
	Hierarchical aggregator	Adds an edge layer to perform partial aggregation of local models from closely-related client devices to improve model quality and system efficiency.
	Secure aggregator	The adoption of secure multiparty computation (MPC) protocols that manages the model exchange and aggregation security to protect model security.

sions from each client and aligns them with their corresponding global model. A *model replacement trigger* initiates a new model training task when the current global model's performance drops below the threshold value. A *deployment selector* deploys the global model to the selected clients (i.e., model users) to improve the model quality for personalised tasks.

Thirdly, patterns about the model training and data preprocessing are summarised as model training patterns, including *multi-task model trainer* that tackles non-IID data characteristics, *heterogeneous data handler* that deals with data heterogeneity in training datasets, and *incentive registry* that increases the client's motivatability through rewards.

Lastly, model aggregation patterns are design solutions of model aggregation used for different purposes. *Asynchronous aggregator* aims to reduce aggregation latency and increase system efficiency, whereas *decentralised aggregator* targets to increase system reliability and accountability. *Hierarchical aggregator* is adopted to improve model quality and optimises resources. *Secure aggregator* is designed to protect the models' security.

We discussed these patterns according to the pattern form presented in [27]. The form comprehensively describes the patterns by discussing the context, problem statement, forces that increase the difficulty to solve the problem, the solution, its consequences (benefits and drawbacks), the related patterns, and the known-uses of the pattern.

4. Federated Learning Patterns

In this section, we will discuss the details of federated learning patterns, which are classified into four categories: client management patterns, model management patterns, model training patterns, and model aggregation patterns.

4.1. Client Management Patterns

The client management patterns handle the client devices' information, communication, and training operations to achieve better model performance and system efficiency.

4.1.1. Pattern 1: Client Registry

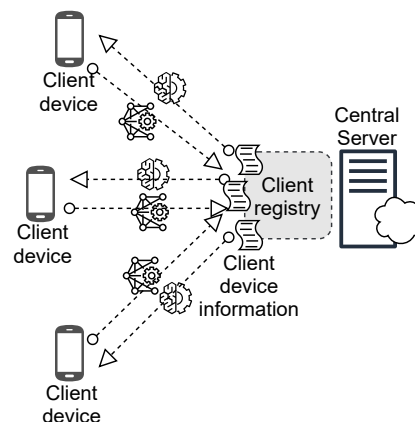

Figure 4: Client Registry.

Summary: A client registry maintains the information of all the participating client devices for client management.

Context: In a federated learning system, the central server communicates with distributed client devices with dynamic connectivity (i.e., client devices frequently disconnect and re-join the systems) and diverse resources.

Problem: It is challenging for a federated learning system to track any dishonest, failed, or dropout node. This is crucial to secure the central server and client devices from adversarial threats. Moreover, to effectively align the model training process of each client device for each aggregation round, a record of the connection and training information of each client device that has interacted with the central server is required.

Forces: The problem requires to balance the following forces:

- *Upgradability.* The ability to keep track of the participating devices is necessary to ensure the information recorded is up-to-date.
- *Data privacy.* The records of client information expose the clients to data privacy issues. For instance, the device usage pattern of users can be inferred from the device connection up-time, device information, resources, etc.

Solution: A client registry records all the information of client devices that are connected with the system from the first time. The information includes device ID, connection up & downtime, device resource information (computation, communication, power & storage). The access to the client registry could be restricted according to the agreement between the central server and participating client devices.

Consequences:

Benefits:

- *Maintainability.* The client registry enables the system to effectively manage the dynamically connecting and disconnecting clients.
- *Reliability.* The client registry provides a status tracking for all the devices, which is essential for problematic node identification.

Drawbacks:

- *Data privacy.* The recording of the device information on the central server leads to client data privacy issues.
- *Cost.* The maintenance of client device information requires extra communication cost and storage cost, which further surges when the number of client devices increases.

Related patterns: *Model Co-Versioning Registry, Client Selector, Client Cluster, Asynchronous Aggregator, Hierarchical Aggregator*

Known uses:

- *IBM Federated Learning*²: *Party Stack* component manages the client parties of IBM federated learning framework, that contains sub-components such as protocol handler, connection, model, local training, and data handler for client devices registration and management.
- *doc.ai*³: Client registry is designed for medical research applications to ensure that updates received apply to a current version of the global model, and the client device does not update a deprecated global model.
- *SIEMENS Mindsphere Asset Manager*⁴: To support the collaboration of federated learning clients on industrial IoT environment, *Industrial Metadata Management* is introduced as a device metadata and asset data manager.

4.1.2. Pattern 2: Client Selector

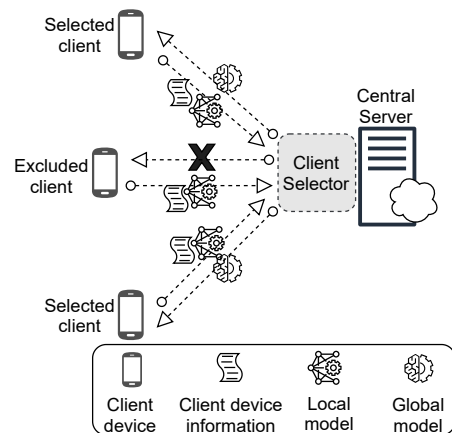

Figure 5: Client Selector.

Summary: A client selector actively selects the client devices for a certain round of training according to the pre-defined criteria to increase model performance and system efficiency.

Context: Federated learning conducts multiple rounds of model exchanges and aggregations that incurs high communication and computation cost.

Problem: The central server has limited resources and is burdensome to accommodate the communication with all the client devices every round.

Forces: The problem requires the following forces to be balanced:

- *Latency.* Client devices have system heterogeneity (difference in computation, communication, and energy resources) that affect the local model training and global model aggregation time.
- *Model quality.* Client devices are statistically heterogeneous (different data distribution/quality) that produce lo-

²<https://github.com/IBM/federated-learning-lib>

³<https://doc.ai/>

⁴<https://documentation.mindsphere.io/resources/html/asset-manager/en-US/index.html>

cal model parameters or gradients that overfits the local data (not generalised to the overall data pattern).

Solution: Selecting client devices with predefined criteria can optimise the formation of the global model. The client selector on the central server performs client selection every round to include the best fitting client devices for global model aggregation. The selection criteria can be configured as follow:

- **Resource-based:** The central server assesses the resources available on each client devices every training round and selects the client devices with the satisfied resource status (e.g., WiFi connection, pending status, sleep time)
- **Data-based:** The central server examines the data distribution of each client device and excludes the devices with data that are highly heterogeneous compared with other devices.
- **Performance-based:** Performance-based client selection can be conducted through local model assessment (e.g. based on the performance of the local model trained last round or the historical records of local model performance).

Consequences:

Benefits:

- **Resource optimisation.** The client selection optimises the resource usage of the central server to compute and communicate with suitable client devices for each aggregation round, without wasting resources to aggregate the low-quality models.
- **System performance.** Selecting clients with sufficient power and network bandwidth greatly reduces the chances of clients dropping out and lowers the communication latency.
- **Model performance.** Selecting clients with the higher local model performance or lower data heterogeneity increases the global model quality.

Drawbacks:

- **Model generality.** The exclusion of models from certain client devices may lead to the missing of essential data features and the loss of the global model generality.
- **Data privacy.** The central server needs to acquire the system and resource information (processor's power, network availability, bandwidth, remaining power, online status, etc.) every round to perform ranking and selection of devices. Access to client devices' information creates data privacy issues.
- **Computation cost.** Extra resources are spent on transferring of the required information for selection decision-making.

Related patterns: *Client Registry, Deployment Selector*

Known uses:

- **Google's FedAvg:** Client selection is first introduced by Google in its FedAvg [26] algorithm that randomly selects a subset of clients for each round based on predefined environment conditions and device specification of the client devices.
- In **IBM's ELFISH** [38], there is a training consumption profiling function that fully profiles the resource consumption for model training on client devices. Based on that profiling, a resource-aware soft-training scheme is designed to accelerate local model training on heterogeneous devices and prevent stragglers from delaying the collaborative learning process.
- **FedCS** suggested by OMRON SINIC X Corporation⁵ sets a certain deadline for clients to upload the model updates.
- **Communication-Mitigated Federated Learning (CMFL)** [33] excludes the irrelevant local updates by identifying the relevance of a client update by comparing its global tendency of model updating with all the other clients.
- **CDW_FedAvg** [41] takes the centroid distance between the positive and negative classes of each client dataset into account for aggregation.

4.1.3. Pattern 3: Client Cluster

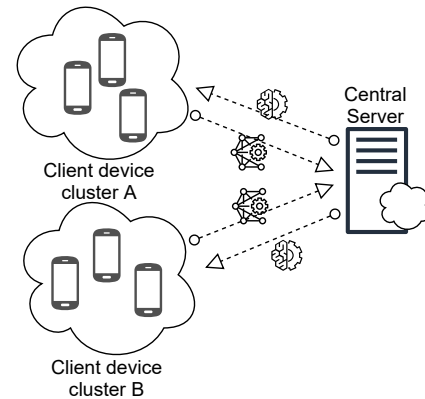

Figure 6: Client Cluster.

Summary: A client cluster groups the client devices (i.e. model trainers) based on their similarity on certain characteristics (e.g., available resources, data distribution, features, geolocation) to increase the model performance and training efficiency.

Context: Federated learning systems possess statistical and system challenges as models are trained over distributed networks of client devices.

Problem: Federated learning models generated under non-IID data properties are deemed to be less generalised. This is due to the lack of significantly representative data labels from the client devices. Furthermore, local models may drift significantly from each other.

⁵<https://www.omron.com/sinicx/>

Forces: The problem requires to balance the following forces:

- *Computation cost and training time.* More computation costs and longer training time are required to solve the non-IID issue of client devices.
- *Data privacy.* Access to the entire or parts of the client's raw data is needed by the learning coordinator to solve the non-IID issue and this creates data privacy risks.

Solution: Client devices that are model trainers are clustered into different groups according to their properties (e.g., data distribution, features similarities, gradient loss). By creating clusters of clients with similar data patterns, the global model generated will have better performance for the non-IID-severe client network, without accessing the local data.

Consequences:

Benefits:

- *Model quality.* The global model created by client clusters can have a higher model performance for highly personalised prediction tasks.
- *Convergence speed.* The consequent deployed global models can have faster convergence speed as the models of the same cluster can identify the gradient much faster when the clients' data distribution and IIDness are similar.

Drawbacks:

- *Computation cost.* The central server consumes extra computation cost and time for client clustering and relationship quantification.
- *Data privacy.* The learning coordinator (i.e., central server) requires extra client device information (e.g., data distribution, feature similarities, gradient loss) to perform clustering. This exposes the client devices to the possible risk of private data leakage.

Related patterns: *Client Registry, Client Selector, Deployment Selector*

Known uses:

- Iterative Federated Clustering Algorithm (*IFCA*)⁶ is a framework introduced by UC Berkley and Google to cluster client devices based on the loss values of the client's gradient.
- Clustered Federated Learning (*CFL*)⁷ uses a cosine-similarity-based clustering method that creates a bi-partitioning to group client devices with the same data generating distribution into the same cluster.
- *TiFL* [6] is a tier-based federated learning system that adaptively groups client devices with similar training time per round to mitigate the heterogeneity problem without affecting the model accuracy.

⁶<https://github.com/jichan3751/ifca>

⁷<https://github.com/felisat/clustering-federated-learning>

- Patient clustering in a federated learning system is implemented by Massachusetts General Hospital to improve efficiency in predicting mortality and hospital stay time [13].

4.2. Model Management Patterns

The model management patterns manage versions of the models and coordinate the exchanges, updates, and deployment of local and global models during and after the training.

4.2.1. Pattern 4: Message Compressor

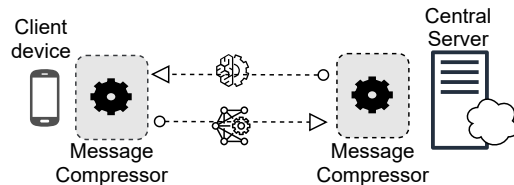

Figure 7: Message Compressor.

Summary: A message compressor reduces the message data size before every round of model exchange to increase the communication efficiency.

Context: Federated learning requires multiple rounds of model communication between a central server and many client devices to complete the model training.

Problem: Communication cost for model communication (e.g., transferring model parameters or gradients) is often a critical bottleneck when the system scales up, especially for bandwidth-limited client devices.

Forces: The problem requires to balance the following forces:

- *Computation cost.* High computation costs are required by the central server to aggregate all the bulky model parameters collected every round.
- *Communication cost.* Extra communication costs are consumed to communicate the model parameters and gradients between resource-limited client devices and the central server.

Solution: The model parameters and the training task script as one message package is compressed before being transferred between the central server and client devices. The compression of model parameters can be performed upstream (client device to central server), downstream (central server to client device), or two-way communication.

Consequences:

Benefits:

- *Communication efficiency.* The compression of model parameters reduces the communication cost and network throughput for model exchanges.
- *Aggregation efficiency.* The aggregation of model parameters with a smaller size of data or feature dimensions incurs lower computation cost on the central server.

Drawbacks:

- *Computation cost.* Extra computation is required for message compression and decompression every round.
- *Loss of information.* The downsizing of the model parameters might cause the loss of essential information.

Related patterns: *Client Registry, Model Co-Versioning Registry*

Known uses:

- *Google Sketched Update* [19]: Google proposes two communication efficient update approaches: structured update and sketched update. Structured update directly learns an update from a restricted space that can be parametrised using a smaller number of variables, whereas sketched updates compress the model before sending it to the central server.
- *IBM PruneFL* [16] adaptively prunes the distributed parameters of the models, including initial pruning at a selected client and further pruning as part of the federated learning process.
- *FedCom* [11] compresses messages for uplink communication from the client device to the central server. The central server produces a convex combination of the previous global model and the average of updated local models to retain the essential information of the compressed model parameters.

4.2.2. Pattern 5: Model Co-versioning Registry

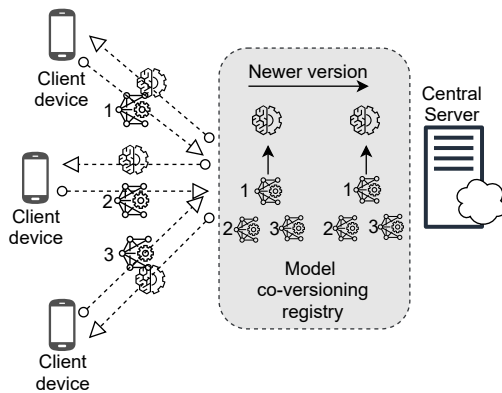

Figure 8: Model Co-versioning Registry.

Summary: A model co-versioning registry records all local model versions from each client and aligns them with their corresponding global model. This enables the tracing of model quality and adversarial client devices at any specific point of the training to improve system accountability.

Context: Federated learning creates multiple new versions of local models from different client devices and one global model each round. For instance, a federated learning task that runs for 100 rounds on 100 devices will create 10,000 local models and 100 global models in total.

Problem: With high numbers of local models created each round, it is challenging to keep track of which local models contributed to the global model of a specific round. Furthermore, the system needs to handle the challenges of asynchronous updates, client dropouts, model selection, etc.

Forces: The problem requires to balance the following forces:

- *Updatability.* The system needs to keep track of the local and global models concerning each client device's updates (application's version or device OS/firmware updates) and the information recorded is up-to-date.
- *Immutability.* The records and storage of the models co-versions and client IDs needs to be immutable.

Solution: A model co-versioning registry records the local model version of each client device and the global model it corresponds to. Based on the record, the global model version is mapped to the local model updates of the round. This enables seamless synchronous and asynchronous model updates and aggregation. Furthermore, the model co-versioning registry enables the early-stopping of complex model training (stop training when the local model overfits and retrieve the best performing model previously). This can be done by observing the performance of the aggregated global model. If the global model performance increases gradually after each aggregation but experiences a sudden drop compared to the previous model (diverges from the previous global model/gradient), one or more local models might be overfitted to their local data and causes the global model divergence. Moreover, to provide accountable model provenance and co-versioning, blockchain is considered as one alternative to the central server due to its characteristics of immutability and decentralisation.

Consequences:

Benefits:

- *Model quality.* The mapping of local models with their corresponding version of the global model allows the study of the effect of each local model quality on the global model.
- *Accountability.* System accountability increases when stakeholders can trace the local models that correspond to the current or previous global model versions.
- *System security.* The registry allows adversarial or dishonest client identification based on the global model performance and tracks the local models that cause the failure of the system.

Drawbacks:

- *Storage cost.* Extra storage cost is incurred to store all the local and global models and their mutual relationships. Storage cost multiplies when the number of client devices increases. The record also needs to be easily retrievable and this becomes challenging if the central server host more than one task.

Related patterns: *Client Registry*

Known uses:

- *DVC*⁸ is an online machine learning version control platform built to make models shareable and reproducible.
- *MLflow Model Registry*⁹ on Databricks is a centralized model store that provides chronological model lineage, model versioning, stage transitions, and descriptions.
- *Replicate.ai*¹⁰ is an open-source version control platform for machine learning that automatically tracks code, hyperparameters, training data, weights, metrics, and system dependencies.
- *Pachyderm*¹¹ is an online machine learning pipeline platform that uses containers to execute the different steps of the pipeline and also solves the data versioning provenance issues.

4.2.3. Pattern 6: Model Replacement Trigger

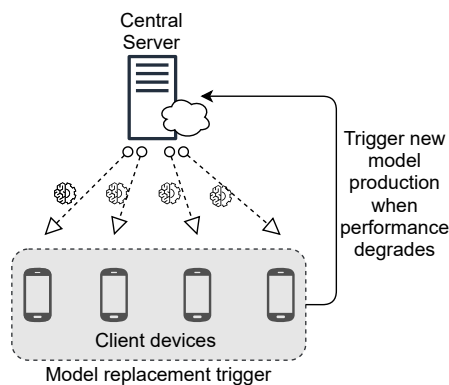

Figure 9: Model Replacement Trigger.

Summary: A model replacement trigger initiates a new model training task when the current global model’s performance drops below the threshold value. A new global model generation is initiated if the current model does not meet the threshold.

Context: The client devices use converged global models for inference or prediction.

Problem: As new data is introduced to the system, the global model accuracy might reduce gradually. Eventually, with the degrading performance, the model is no longer suitable for the application.

Forces: The problem requires to balance the following forces:

- *Model quality.* The global model deployed might experience a performance drop when new data are used for inference and prediction.

- *Performance degradation detection.* The system needs to effectively determine the reason for the global model’s performance degradation before deciding whether to activate a new global model generation.

Solution: A model replacement trigger initiates a new model training task when the acting global model’s performance drops below the threshold value. It will compare the performance of the deployed global model on a certain number of client devices to determine if the degradation is a global event. When the global model performance is lower than the preset threshold value for more than a fixed number of consecutive times, given that performance degradation is a global event, a new model training task is triggered.

Consequences:

Benefits:

- *Updatability.* The consistent updatability of the global model helps to maintain system performance and reduces the non-IID data effect. It is especially effective for clients that generate highly personalised data that causes the effectiveness of the global model to reduce much faster as new data is generated.
- *Model quality.* The ongoing model performance monitoring is effective to maintain the high quality of the global model used by the clients.

Drawbacks:

- *Computation cost.* The client devices will need to perform model evaluation periodically that imposes extra computational costs.
- *Communication cost.* The sharing of the evaluation results among clients to know if performance degradation is a global event is communication costly.

Related patterns: *Client Registry, Client Selector, Model Co-versioning Registry*

Known uses:

- *Microsoft Azure Machine Learning Designer*¹² provides a platform for machine learning pipeline creation that enables models to be retrained on new data.
- *Amazon SageMaker*¹³ provides model deployment and monitoring services to maintain the accuracy of the deployed models.
- *Alibaba Machine Learning Platform*¹⁴ provides end-to-end machine learning services, including data processing, feature engineering, model training, model prediction, and model evaluation.

⁸<https://dvc.org/>

⁹[https://docs.databricks.com/applications/mlflow/model-registry.h](https://docs.databricks.com/applications/mlflow/model-registry.html)

tml

¹⁰<https://replicate.ai/>

¹¹<https://www.pachyderm.com/>

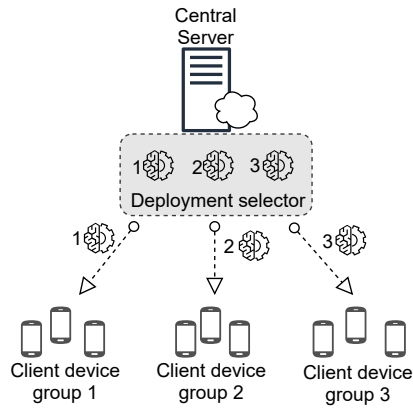

Figure 10: Deployment Selector.

4.2.4. Pattern 7: Deployment Selector

Summary: A deployment selector deploys the global model to the selected clients (i.e., model users) to improve the model quality for different applications and tasks.

Context: In federated learning systems, clients might have similar feature space but a small overlap of samples as they generate highly different data patterns. For multitask federated learning settings, a model is trained using data from multiple applications to perform similar and related tasks. These models need to be deployed to suitable groups of client devices.

Problem: Due to the inherent diversity and non-IID distribution among local data, the globally trained model may not be accurate enough for all clients or tasks.

Forces: The problem requires to balance the following forces:

- *Identification of clients.* The central server needs to match and deploy the global models to the different groups of client devices.
- *Training and storage of different models.* The central server needs to train and store different global models for diverse clients or applications.

Solution: A deployment selector examines and selects clients (i.e., model users) to receive the global model specified for them based on their data characteristics or applications. The deployment selector deploys the model to the client devices once the global model is completely trained.

Consequences:

Benefits:

- *Model performance.* Deploying global models to suitable groups of client devices enhances the model performance to the specific groups of clients or applications.

¹²<https://azure.microsoft.com/en-au/services/machine-learning/designer/>

¹³<https://aws.amazon.com/sagemaker/>

¹⁴<https://www.alibabacloud.com/product/machine-learning>

Drawbacks:

- *Cost.* There are extra costs for training of multiple personalised global models, deployment selection, storage of multiple global models.
- *Model performance.* The statistical heterogeneity of model trainers produces personalised local models, which is then generalised through *FedAvg* aggregation. We need to consider the performance trade-off of the generalised global model deployed for different model users and applications.
- *Data privacy.* Data privacy challenges exist when the central server collects the client information to identify suitable models for different clients. Moreover, the global model might be deployed to model users that have never joined the model training process.

Related patterns: *Client Registry, Client Selector*

Known uses:

- *Azure Machine Learning*¹⁵ supports mass deployment with a step of compute target selection.
- *Amazon SageMaker*¹⁶ can host multiple models with multi-model endpoints.
- *Google Cloud*¹⁷ uses model resources to manage different versions of models.

4.3. Model Training Patterns

To deal with non-IID data and low client participation rate in federated training, the following model training patterns can be adopted to improve the model performance.

4.3.1. Pattern 8: Multi-Task Model Trainer

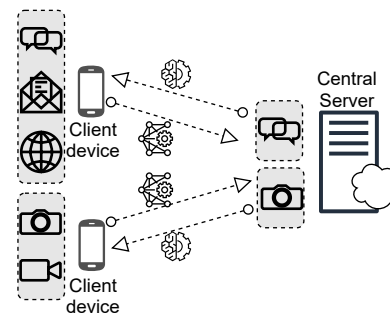

Figure 11: Multi-Task Model Trainer.

Summary: In federated learning, a multi-task model trainer trains separated but related models on local client devices to improve learning efficiency and model performance.

Context: Federated learning systems have statistical heterogeneity where the data distribution among different clients is

¹⁵<https://docs.microsoft.com/en-us/azure/machine-learning/concept-model-management-and-deployment>

¹⁶<https://docs.aws.amazon.com/sagemaker/latest/dg/multi-model-endpoints.html>

¹⁷<https://cloud.google.com/ai-platform/prediction/docs/deploying-models>

skewed and a global model cannot capture the needs of each client.

Problem: Federated learning models trained with non-IID data suffer from low accuracy and are less generalised to the entire dataset. Furthermore, the local data that is highly personalised to the device users' usage pattern creates local models that diverge in different directions. Hence, the global model may have relatively low averaged accuracy.

Forces: The problem requires to balance the following forces:

- *Computation cost.* The complex model that solves the non-IID issue consumes more computation and energy resources every round compared to general federated model training. It also takes longer to compute all the training results from the different tasks before submitting them to the central server.
- *Data privacy.* To address the non-IID issue, more information from the local data needs to be explored to understand the data distribution pattern. This ultimately exposes client devices to local data privacy threats.

Solution: The multi-task model trainer performs similar-but-related machine learning tasks on client devices. This enables the local model to learn from more local data that fit naturally to the separate local models for different tasks. For instance, a multi-task model for the next-word prediction task is trained using the on-device text messages, web browser search strings, and emails with similar mobile keyboard usage patterns. *MOCHA* [30] is a state-of-the-art federated multi-task learning algorithm that realises distributed multi-task learning on federated settings while dynamically handles loosely-joint client devices, mitigating stragglers, and increase fault tolerance.

Consequences:

Benefits:

- *Model quality.* Multi-task learning improves the model performance by considering local data and loss in optimization and obtaining a local weight matrix through this process. The local model fits for non-IID data in each node better than a global model.

Drawbacks:

- *Model quality.* Multi-task training often works only with convex loss functions and performs weak on non-convex loss functions.
- *Model portability.* As each client has a different model, the model's portability is a problem that makes it hard to apply multi-task training on cross-device FL.

Related patterns: *Client Registry, Model Co-versioning Registry, Client Cluster, Deployment Selector*

Known uses:

- *MultiModel*¹⁸ is a neural network architecture by Google that simultaneously solves several problems spanning multiple domains, including image recognition, translation, and speech recognition.
- *MT-DNN*¹⁹ is an open-source natural language understanding toolkit by Microsoft to train customized deep learning models.
- *Yahoo Multi-Task Learning for Web Ranking* is a multi-task learning framework developed by Yahoo! Labs to rank in web search.
- *VIRTUAL* [8] is an algorithm for federated multi-task learning with non-convex models. The federated network of the central server and the client devices are treated as a star-shaped bayesian network, and model learning is performed on the network using approximated variational inference.

4.3.2. Pattern 9: Heterogeneous Data Handler

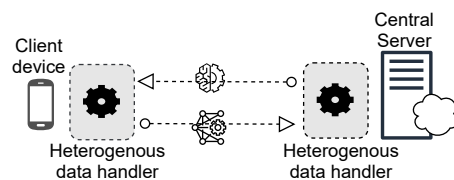

Figure 12: Heterogeneous Data Handler.

Summary: Heterogeneous data handler solves the non-IID and skewed data distribution issues through data volume and data class addition (e.g., data augmentation or generative adversarial network) while maintaining the local data privacy.

Context: Client devices possess heterogeneous data characteristics due to the highly personalized data generation pattern. Furthermore, the raw local data cannot be shared so the data balancing task becomes extremely challenging.

Problem: The imbalanced and skewed data distribution of client devices produces local models that are not generalised to the entire client network. The aggregation of these local models reduces global model accuracy.

Forces: The problem requires the following forces to be balanced:

- *Data efficiency.* It is challenging to articulate the suitable data volume and classes to be augmented to solve data heterogeneity on local client devices.
- *Data accessibility.* The heterogeneous data issue that exists within the client device can be solved by collecting all the data under a centralized location. However, this violates the data privacy of client devices.

¹⁸<https://ai.googleblog.com/2017/06/multimodel-multi-task-machine-learning.html>

¹⁹<https://github.com/microsoft/MT-DNN>

Solution: A heterogeneous data handler balances the data distribution and solves the data heterogeneity issue in the client devices through data augmentation, Generative Adversarial Network (GAN), and federated distillation. Data augmentation solves data heterogeneity by generating augmented data locally until the data volume is the same across all client devices. Furthermore, the classes in the datasets are also populated equally across all client devices. GAN is a generative model that empowers each device to locally reproduce the data samples of all devices to make the training dataset become IID. Finally, federated distillation enables the client devices to obtain knowledge from other devices periodically without directly accessing the data of other client devices. Another method is taking the quantified data heterogeneity weightage (e.g., Pearson’s correlation, centroid averaging-distance, etc.) into account for model aggregation.

Consequences:

Benefits:

- *Model quality.* By solving the non-IID issue of local datasets, the performance and generality of the global model are improved.

Drawbacks:

- *Computation cost.* It is computationally costly to deal with data heterogeneity together with the local model training.

Related patterns: *Client Registry, Client Selector, Client Cluster*

Known uses:

- *Astreea* [9] is a self-balancing federated learning framework that alleviates the imbalances by performing global data distribution-based data augmentation.
- Federated Augmentation (*FAug*) [14] is a data augmentation scheme that utilises a generative adversarial network (GAN) which is collectively trained under the trade-off between privacy leakage and communication overhead.
- Federated Distillation (*FD*) [1] is a method that adopted knowledge distillation approaches to tackle the non-IID issue by obtaining the knowledge from other devices during the distributed training process, without accessing the raw data.

4.3.3. Pattern 10: Incentive Registry

Summary: An incentive registry maintains the list of participating clients and their rewards that correspond to clients’ contributions (e.g., data volume, model performance, computation resource) to motivate clients’ participation.

Context: The participation of client devices is essential for global model performance.

Problem: Although the system relies greatly on the participation of clients to produce high-quality global models,

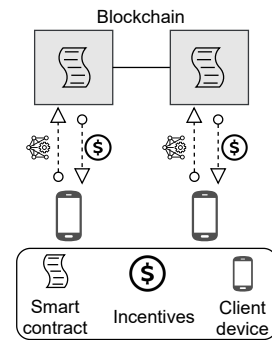

Figure 13: Incentive Registry.

clients are not mandatory to join the model training and contribute their data/resources.

Forces: The problem requires to balance the following forces:

- *Incentive scheme.* It is challenging to formulate the form of rewards to attract different clients with different participation motives. Furthermore, the incentive scheme needs to be agreed upon by both the learning coordinator and the clients, e.g., performance-based, data-contribution-based, resource-contribution-based, and provision-frequency-based.
- *Data privacy.* To identify the contribution of each client device, the local data and client information is required to be studied and analysed by the central server. This exposes the client devices’ local data to privacy threats.

Solution: An incentive registry records all client’s contributions and incentives based on the rate agreed. There are various ways to formulate the incentive scheme, e.g., deep reinforcement learning, blockchain/smart contracts, and the Stackelberg game model.

Consequences:

Benefits:

- *Client motivatability.* The incentive mechanism is effective in attracting clients to contribute data and resources to the training process.

Drawbacks:

- *System security.* There might be dishonest clients that submit fraudulent results to earn rewards illegally and harm the training process.

Related patterns: *Client Registry, Client Selector*

Known uses:

- *FLChain* [2] is a federated learning blockchain providing an incentive scheme for collaborative training and a market place for model trading.
- *DeepChain* [35] is a blockchain-based collaborative training framework with an incentive mechanism that encour-

ages parties to participate in the deep learning model training and share the obtained local gradients.

- *FedCoin* [23] is a blockchain-based peer-to-peer payment system for federated learning to enable Shapley Value (SV) based reward distribution.

4.4. Model Aggregation Patterns

In this section, various model aggregation patterns of federated learning systems are elaborated. These aggregation patterns aim to solve model performance, system efficiency, and security issues.

4.4.1. Pattern 11: Asynchronous Aggregator

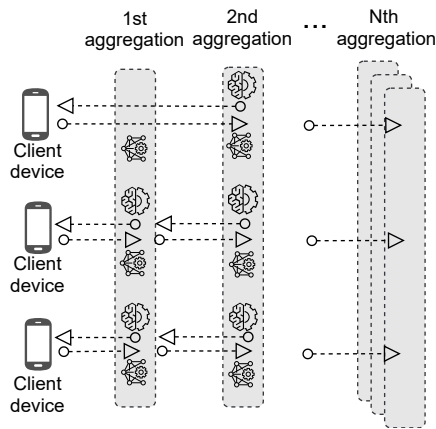

Figure 14: Asynchronous Aggregator.

Summary: To increase the global model aggregation speed every round, the central server can perform model aggregation asynchronously whenever a model update arrives without waiting for all the model updates every round.

Context: In conventional federated learning, the central server receives all local model updates from the distributed client devices synchronously and performs model aggregation every round. The central server needs to wait for every model to arrive before performing the model aggregation for that round. Hence, the aggregation time depends on the last model update that reaches the central server.

Problem: Due to the difference in computation resources, the model training lead time is different per device. Furthermore, the difference in bandwidth availability, communication efficiency affects the model's transfer rate. Therefore, the delay in model training and transfer increases the latency in global model aggregation.

Forces: The problem requires the following forces to be balanced:

- *Model quality.* There will be possible bias in the global model if not all local model updates are aggregated in every iteration as important information or features might be left out.
- *Aggregation latency.* The aggregation of local models can only be performed when all the model updates are col-

lected. Therefore, the latency of the aggregation process is affected by the slowest model update that arrives at the central server.

Solution: The global model aggregation will be conducted whenever a model update is received, without being delayed by other clients. Then the server starts the next iteration and distributes the new central model to the ready clients. The delayed model updates that are not included in the current aggregation round will be added in the next round with some reduction in the weightage compared with the latest updates, proportioned to their respective delayed time.

Consequences:

Benefits:

- *Low aggregation latency.* Faster aggregation time per round is achievable as there is no need to wait for the model updates from other clients for the aggregation round. The bandwidth usage per iteration is reduced as fewer local model updates are transferred and receive simultaneously every round.

Drawbacks:

- *Communication cost.* The number of iteration to collect all local model updates increases for the asynchronous approach. More iterations are required for the entire training process to train the model till convergence compares to synchronous global model aggregation.
- *Model bias.* The global model of each round does not contain all the features and information of every local model update. Hence the global model might have a certain level of bias in prediction.

Related patterns: *Client Registry, Client Selector, Model Co-versioning Registry, Client Update Scheduler*

Known uses:

- Asynchronous Online Federated Learning (*ASO-fed*) [7] is a framework for federated learning that adopted asynchronous aggregation. The central server begins to update the global model when it receives a local update from one client device (or several client devices if the local updates are received simultaneously). On the client device side, online-learning is performed as data continue to arrive during the global iterations. Each client requests the latest model from the central server and updates the model with its new data.
- Asynchronous federated SGD-Vertical Partitioned (*AFSGD-VP*) [10] algorithm uses a tree-structured communication scheme to perform asynchronous aggregation. The algorithm does not need to align the iteration number of the model aggregation from different client devices to compute the global model. The local model update from a client device is paired with the nearest client device that has completed the local model training for aggregation, without needing to align the iteration number of the model aggregation from different client devices.

- Asynchronous Federated Optimization (*FedAsync*) [36] is an approach that leverages asynchronous updating technique and avoids server-side timeouts and abandoned rounds while requires no synchronous model broadcast to all the selected client devices.

4.4.2. Pattern 12: Decentralised Aggregator

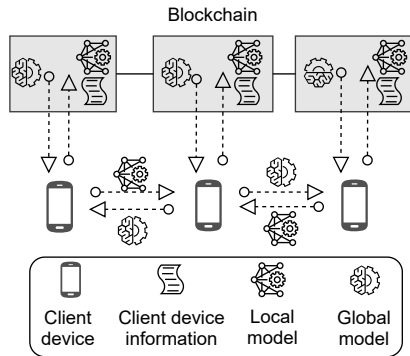

Figure 15: Decentralised Aggregator.

Summary: A decentralised aggregator improves system reliability and accountability by removing the central server that is a possible single-point-of-failure.

Context: The conventional federated learning system is coordinated by a central server to perform the model training and aggregation. The learning coordinator and the owned central server need to be trusted by all the client devices that join the training process.

Problem: In *FedAvg*, all the chosen devices have to submit the model parameters to one central server every round. This is extremely burdensome to the central server and network congestion may occur. Furthermore, centralised federated learning possesses a single-point-of-failure. Data privacy threats may also occur if the central server is compromised by any unauthorised entity. Furthermore, the central server is presumed as a trusted component owned by a trusted party. However, the mutual trust between the client devices and the central server is not specifically established.

Forces: The problem requires to balance the following forces:

- *Decentralised model management.* The federated learning systems face challenges to collect, store, examine, and aggregate the local models due to the removal of the central server.
- *System ownership.* Currently, the central server is own by the learning coordinator that creates the FL jobs. The removal of the central server requires the re-definition of system ownership. It includes the authority and accessibility of learning coordinator in the FL systems.

Solution: A decentralised aggregator replaces the central server's role in a federated learning system. The aggregation and update of the model parameters can be performed through peer-to-peer exchanges between client devices. Firstly,

a random client from the system can be an aggregator by requesting the model updates from the other clients. Simultaneously, all the client devices conduct local model training parallelly and send the trained local models to the aggregator. The aggregator then produces a new global model and sends it to the client network. The process continues until the global model converges. Blockchain is the alternative to the central server for model storage that prevents single-point-of-failure. The ownership of the blockchain belongs to the learning coordinator that creates the new training tasks and maintains the blockchain. Furthermore, the record of models on a blockchain is immutable that increases the reliability of the system. It also increases the trust of the system as the record is transparent and accessible by all the client devices.

Consequences:

Benefits:

- *System reliability.* The removal of single-point-of-failure increases the system reliability by reducing the security risk of the central server from any adversarial attack or the failure of the entire training process due to the malfunction of the central server.
- *System accountability.* The adoption of blockchain promotes accountability as the records on a blockchain is immutable and transparent to all the stakeholders.

Drawbacks:

- *Latency.* Client device as a replacement of the central server for model aggregation is not ideal for direct communication with multiple devices (star-topology). This may cause latency in the model aggregation process due to blockchain consensus protocols.
- *Computation cost.* Client devices have limited computation power and resource to perform model training and aggregation parallel. Even if the training process and the aggregation is performed sequentially, the energy consumption to perform multiple rounds of aggregation is very high.
- *Storage cost.* High storage cost is required to store all the local and global models on storage-limited client devices or blockchain.
- *Data privacy.* Client devices can access the record of all the models under decentralized aggregation and blockchain settings. This might expose the privacy-sensitive information of the client devices to other parties.

Related patterns: *Model Co-versioning Registry, Incentive Registry*

Known uses:

- *BrainTorrent* [28] is a server-less, peer-to-peer approach to perform federated learning where clients communicate directly among themselves, specifically for federated learning in medical centers.

- *FedPGA* [15] is a decentralised aggregation algorithm developed from *FedAvg*. The devices in *FedPGA* exchange partial gradients rather than full model weights. The partial gradient exchange pulls and merges the different slice of the updates from different devices and rebuild a mixed update for aggregation.
- A fully decentralised framework [21] is a distributed learning algorithm in which users update their beliefs by aggregate information from their one-hop neighbors to learn a model that best fits the observations over the entire network.
- A Segmented gossip approach [12] splits a model into a set of segmentation that contains the same number of non-overlapping model parameters. Then, the gossip protocol is adopted where each client stochastically selects a few other clients to exchange the model segmentation for each training iteration without the orchestration of a central server.

4.4.3. Pattern 13: Hierarchical Aggregator

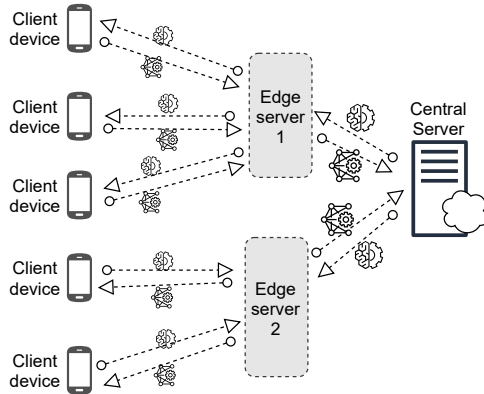

Figure 16: Hierarchical Aggregator.

Summary: To reduce non-IID effects on the global model and increase system efficiency, a hierarchical aggregator adds an intermediate layer (e.g., edge server) to perform partial aggregations using the local model parameters from closely-related client devices before the global aggregation.

Context: In general cases, the central server and client devices are the only two hardware components in a conventional federated learning system that are physically distant from each other and are wirelessly connected.

Problem: The central server can access and store more data but requires high communication overhead and suffers from latency due to being physically distant from the client devices. Moreover, client devices possess non-IID characteristics that affect global model performance.

Forces: The problem requires the following forces to be balanced:

- *System efficiency.* The system efficiency of the server-client setting to perform federated learning is low, as the

central server is burdensome to accommodate the communication and the model aggregations of the widely-distributed client devices.

- *Data heterogeneity.* In the server-client setting of a federated learning system, the data heterogeneity characteristics of client devices become influential and dominant to the global model production, as the central server deals with all the client devices that generate non-IID data.

Solution: A hierarchical aggregator adds edge servers between the central server and client devices. The combination of server-edge-client architecture can improve both computation and communication efficiency of the federated model training process. Edge servers collect local models from the nearest client devices, a subset of all the client devices. After every k_1 round of local training on each client, each edge server aggregates its clients' models. After every k_2 edge model aggregations, the cloud server aggregates all the edge servers' models, which means the communication with the central server happens every $k_1 k_2$ local updates [22].

Consequences:

Benefits:

- *Communication efficiency.* The hierarchical aggregators speed up the global model aggregation and improve communication efficiency.
- *Scalability.* Adding an edge layer helps to scale the system by improving the system's ability to handling more client devices.
- *Data heterogeneity and non-IID reduction.* The partial aggregation in a hierarchical manner aggregates local models that have similar data heterogeneity and non-IIDness before the global aggregation on the central server. This greatly reduces the effect of data heterogeneity and non-IIDness on global models.
- *Computation and storage efficiency.* The edge devices are rich with computation and storage resources to perform partial model aggregation. Furthermore, edge devices are nearer to the client devices which increase the model aggregation and computation efficiency.

Drawbacks:

- *System reliability.* The maintenance of all the edge devices is challenges and costly due to their distributed manner. The failure of edge devices may cause the disconnection of all the client devices under those edge servers and affect the model training process, model performance, and system reliability.
- *System security.* Edge servers could become security breach points as they have lower security setups than the central server and the client devices. Hence, they are more prone to network security threats or becoming possible points-of-failure of the system.

Related patterns: *Client Registry, Client Cluster, Model Co-versioning Registry*

Known uses:

- *HierFAVG* is an algorithm that allows multiple edge servers to perform partial model aggregation incrementally from the collected updates from the client devices.
- Hierarchical Federated Learning (*HFL*) enables hierarchical model aggregation in large scale networks of client devices where communication latency is prohibitively large due to limited bandwidth. The *HFL* seeks a consensus on the model and uses edge servers to aggregate model updates from client devices that are geographically near.
- Federated Learning + Hierarchical Clustering (*FL+HC*) is the addition of a hierarchical clustering algorithm to the federated learning system. The cluster is formed according to the data distributions similarity based on the following distance metrics: (1) Manhattan, (2) Euclidean, (3) Cosine distance metrics.
- *Astraea* is a federated learning framework that tackles non-IID characteristics of federated clients. The framework introduces a mediator to the central server and the client devices to balance the skewed client data distributions. The mediator performs the z-score-based data augmentation and downsampling to relieve the global imbalanced of training data.

4.4.4. Pattern 14: Secure Aggregator

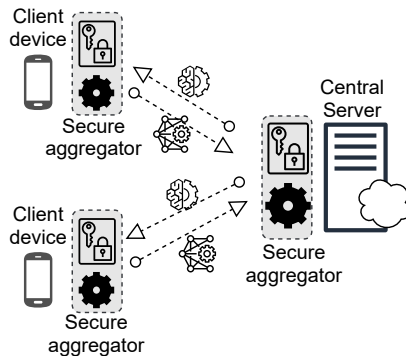

Figure 17: Secure Aggregator.

Summary: A security aggregator manages the model exchange and aggregation security protocols to protect model security.

Context: The central server sends global models to any readily-known or unknown device every round with no data privacy and security protocols that protect the communication between the central server and client devices from unauthorised access. Furthermore, model parameters contain pieces of private user information that can be inferred by the data-hungry machine learning algorithms.

Problem: There are no security measures to tackle the honest-but-curious and active adversary security threats which exist

in federated learning systems.

Forces: The problem requires to balance the following forces:

- *Client device security.* Client device security issues exist when dishonest and malicious client devices join the training process and poison the overall model performance by disrupting the training process or providing false updates to the central server.
- *Data security.* Data security of the client devices is challenged when the gradients or model parameters are inferred by unauthorised parties through the data-hungry machine learning algorithms.

Solution: A security aggregator handles the secure multiparty computation (SMC) protocols for model exchanges and aggregations. The protocols provide security proof to guarantee that each party knows only its input and output. For instance, homomorphic encryption is a method to encrypt the models and only allow authorised client devices and the central server to decrypt and access the models. Pairwise masking and differential privacy (DP) methods are applied to reduce the interpretability of the model by unauthorised party [39]. The technique involves adding noise to the parameters or gradient or uses a generalised method.

Consequences:

Benefits:

- *Data security.* The secure aggregator protects the model from being access by adversarial and unauthorised parties through homomorphic encryptions and prevents information leakage due to the data-hungry property of machine learning models.

Drawbacks:

- *System efficiency.* The extra security processes affect the system efficiency if excessive security steps are required every round for every device. It also lowers the training and aggregation speed due to encryption and decryption time.
- *Model performance-privacy trade-off.* The model performance is affected if the model privacy methods aggressively interfere with the model's interpretability due to being excessively obscure.
- *Compromised key.* For encryption and decryption functions, the possible compromise of the security keys increases the privacy threat.

Related patterns: *Client Registry, Model Co-versioning Registry*

Known uses:

- *SecAgg*[4] a practical protocol by Google for secure aggregation in the federated learning settings.
- *HybridAlpha* [37] is a framework that manages the client devices that join the FL process. The security operation includes functional encryption, DP, and SMC.

- *TensorFlow Privacy Library*²⁰ provides an implementation of DP-SGD machine learning.
- *ZamaAI*²¹ is an AI service platform that provides encryption technology that uses a homomorphic compiler to convert the model into an end-to-end encrypted parameters.
- Simple Encrypted Arithmetic Library (*SEAL*)²² is a homomorphic encryption API introduced by Microsoft AI to allow computations to be performed directly on encrypted data.

5. Related Works

To promote enterprise-level adoption of machine learning-based applications, many researchers view machine learning models as a component of a software system so that the challenges in building machine learning models can be tackled through systematic software engineering approaches.

Wan et al. [32] studied how the adoption of machine learning changes software development practices. The work characterises the differences in various aspects of software engineering and task involved for machine learning system development and traditional software development. Lwakatere et al. [25] propose a taxonomy that depicts maturity stages of use of machine learning components in the industrial software system and mapped the challenges to the machine learning pipeline stages. The work identified and classified the software engineering challenges that are faced by different companies when developing software-intensive systems that incorporate machine learning components as guidance for machine learning practitioners.

Building machine learning models is becoming an engineering discipline where practitioners take advantage of tried-and-proven methods to address recurring problems [20]. Washizaki et al. [34] studies the machine learning design patterns and architectural patterns. The paper collects some good and bad software engineering design patterns for machine learning techniques to provide developers with a comprehensive and ordered classification of such patterns. The authors also proposed an architectural pattern for machine learning for improving operational stability [40]. The work separates machine learning systems' components into business logic and machine learning components and focuses on the machine learning pipeline management, data management, and machine learning model versioning operations.

Similarly, the architectural challenges of federated learning can be addressed through software engineering and architectural design approaches. The research on federated learning system design was first done by Bonawitz et. al [5], focusing on the high-level design of a basic federated learning system and its protocol definition. However, there is no study on the definition of architecture patterns or reusable solutions to address federated learning design challenges cur-

rently. Furthermore, federated learning exhibits properties of a distributed system, which creates the need for different considerations that are not dealt with in the conventional centralised machine learning systems. Our work addresses this particular gap with respect to software architecture designs for federated learning as a distributed software system. To the best of our knowledge, this is the first comprehensive and systematic collection of federated learning architectural patterns. The outcomes are intended to provide architectural guidance for practitioners to better design and develop federated learning systems.

6. Conclusion

Federated learning is a data privacy-preserving, distributed machine learning approach to fully utilise the data and resources on IoT and smart mobile devices. Being a distributed system with multiple components and different stakeholders, architectural challenges need to be solved before federated learning can be effectively adopted in the real-world. In this paper, we present 14 federated learning architectural patterns associated with the lifecycle of a model in federated learning. The pattern collection is provided as architectural guidance for architects to better design and develop federated learning systems. In our future work, we will explore the architectural designs that help improve the trust in federated learning.

References

- [1] Ahn, J., Simeone, O., Kang, J., 2019. Wireless federated distillation for distributed edge learning with heterogeneous data, in: 2019 IEEE 30th Annual International Symposium on Personal, Indoor and Mobile Radio Communications (PIMRC), pp. 1–6.
- [2] Bao, X., Su, C., Xiong, Y., Huang, W., Hu, Y., 2019. Flchain: A blockchain for auditable federated learning with trust and incentive, in: 2019 5th International Conference on Big Data Computing and Communications (BIGCOM), pp. 151–159.
- [3] Beck, K., Cunningham, W., 1987. Using pattern languages for object oriented programs, in: Conference on Object-Oriented Programming, Systems, Languages, and Applications (OOPSLA).
- [4] Bonawitz, K., Ivanov, V., Kreuter, B., Marcedone, A., McMahan, H.B., Patel, S., Ramage, D., Segal, A., Seth, K., 2017. Practical secure aggregation for privacy-preserving machine learning, Association for Computing Machinery, New York, NY, USA.
- [5] Bonawitz, K.A., Eichner, H., Grieskamp, W., Huba, D., Ingerman, A., Ivanov, V., Kiddon, C.M., Konečný, J., Mazzocchi, S., McMahan, B., Overveldt, T.V., Petrou, D., Ramage, D., Roselander, J., 2019. Towards federated learning at scale: System design, in: SysML 2019. URL: <https://arxiv.org/abs/1902.01046>. to appear.
- [6] Chai, Z., Ali, A., Zawad, S., Truex, S., Anwar, A., Baracaldo, N., Zhou, Y., Ludwig, H., Yan, F., Cheng, Y., 2020. Tift: A tier-based federated learning system, in: Proceedings of the 29th International Symposium on High-Performance Parallel and Distributed Computing, Association for Computing Machinery, New York, NY, USA. p. 125–136.
- [7] Chen, Y., Ning, Y., Slawski, M., Rangwala, H., 2020. Asynchronous online federated learning for edge devices with non-iid data. *arXiv:1911.02134*.
- [8] Corinzia, L., Buhmann, J.M., 2019. Variational federated multi-task learning. *arXiv:1906.06268*.
- [9] Duan, M., Liu, D., Chen, X., Tan, Y., Ren, J., Qiao, L., Liang, L., 2019. Astraea: Self-balancing federated learning for improving clas-

²⁰<https://github.com/tensorflow/privacy/>

²¹<https://zama.ai/>

²²<https://www.microsoft.com/en-us/research/project/microsoft-seal/>

- sification accuracy of mobile deep learning applications, in: 2019 IEEE 37th International Conference on Computer Design (ICCD), pp. 246–254.
- [10] Gu, B., Xu, A., Huo, Z., Deng, C., Huang, H., 2020. Privacy-preserving asynchronous federated learning algorithms for multi-party vertically collaborative learning. *arXiv:2008.06233*.
- [11] Haddadpour, F., Kamani, M.M., Mokhtari, A., Mahdavi, M., 2020. Federated learning with compression: Unified analysis and sharp guarantees. *arXiv:2007.01154*.
- [12] Hu, C., Jiang, J., Wang, Z., 2019. Decentralized federated learning: A segmented gossip approach. *arXiv:1908.07782*.
- [13] Huang, L., Shea, A.L., Qian, H., Masurkar, A., Deng, H., Liu, D., 2019. Patient clustering improves efficiency of federated machine learning to predict mortality and hospital stay time using distributed electronic medical records. *Journal of Biomedical Informatics* 99, 103291.
- [14] Jeong, E., Oh, S., Kim, H., Park, J., Bennis, M., Kim, S.L., 2018. Communication-efficient on-device machine learning: Federated distillation and augmentation under non-iid private data. *arXiv:1811.11479*.
- [15] Jiang, J., Hu, L., 2020. Decentralised federated learning with adaptive partial gradient aggregation. *CAAI Transactions on Intelligence Technology* 5, 230–236.
- [16] Jiang, Y., Wang, S., Valls, V., Ko, B.J., Lee, W.H., Leung, K.K., Tassiulas, L., 2020. Model pruning enables efficient federated learning on edge devices. *arXiv:1909.12326*.
- [17] Jobin, A., Ienca, M., Vayena, E., 2019. The global landscape of ai ethics guidelines. *Nature Machine Intelligence* 1, 389–399.
- [18] Kitchenham, B., Charters, S., 2007. Guidelines for performing systematic literature reviews in software engineering.
- [19] Konečný, J., McMahan, H.B., Yu, F.X., Richtárik, P., Suresh, A.T., Bacon, D., 2017. Federated learning: Strategies for improving communication efficiency. *arXiv:1610.05492*.
- [20] Lakshmanan, L.V., Munn, M., Robinson, S., 2020. *Machine Learning Design Patterns*.
- [21] Lalitha, A., Shekhar, S., Javidi, T., Koushanfar, F., 2018. Fully decentralized federated learning, in: Third workshop on Bayesian Deep Learning (NeurIPS).
- [22] Liu, L., Zhang, J., Song, S.H., Letaief, K.B., 2020. Client-edge-cloud hierarchical federated learning, in: ICC 2020 - 2020 IEEE International Conference on Communications (ICC), pp. 1–6.
- [23] Liu, Y., Ai, Z., Sun, S., Zhang, S., Liu, Z., Yu, H., 2020. FedCoin: A Peer-to-Peer Payment System for Federated Learning. Springer International Publishing, Cham. pp. 125–138.
- [24] Lo, S.K., Lu, Q., Wang, C., Paik, H.Y., Zhu, L., 2021. A systematic literature review on federated machine learning: From a software engineering perspective. accepted by *ACM Comput. Surv.*, minor revision.
- [25] Lwakatere, L.E., Raj, A., Bosch, J., Olsson, H.H., Crnkovic, I., 2019. A taxonomy of software engineering challenges for machine learning systems: An empirical investigation, in: Kruchten, P., Fraser, S., Coallier, F. (Eds.), *Agile Processes in Software Engineering and Extreme Programming*, Springer International Publishing, Cham. pp. 227–243.
- [26] McMahan, H.B., Moore, E., Ramage, D., Hampson, S., y Arcas, B.A., 2017. Communication-efficient learning of deep networks from decentralized data. *arXiv:1602.05629*.
- [27] Meszaros, G., Doble, J., 1997. *A Pattern Language for Pattern Writing*. Addison-Wesley Longman Publishing Co., Inc., USA. p. 529–574.
- [28] Roy, A.G., Siddiqui, S., Pölsterl, S., Navab, N., Wachinger, C., 2019. Braintorrent: A peer-to-peer environment for decentralized federated learning. *arXiv:1905.06731*.
- [29] Sattler, F., Wiedemann, S., Müller, K.R., Samek, W., 2020. Robust and communication-efficient federated learning from non-i.i.d. data. *IEEE Transactions on Neural Networks and Learning Systems* 31, 3400–3413.
- [30] Smith, V., Chiang, C.K., Sanjabi, M., Talwalkar, A., 2018. Federated multi-task learning. *arXiv:1705.10467*.
- [31] Voigt, P., Bussche, A.v.d., 2017. *The EU General Data Protection Regulation (GDPR): A Practical Guide*. 1st ed., Springer Publishing Company, Incorporated.
- [32] Wan, Z., Xia, X., Lo, D., Murphy, G.C., 2019. How does machine learning change software development practices? *IEEE Transactions on Software Engineering* , 1–1.
- [33] WANG, L., WANG, W., LI, B., 2019. Cmf1: Mitigating communication overhead for federated learning, in: 2019 IEEE 39th International Conference on Distributed Computing Systems (ICDCS), pp. 954–964.
- [34] Washizaki, H., Uchida, H., Khomh, F., Guéhéneuc, Y., 2019. Studying software engineering patterns for designing machine learning systems, in: 2019 10th International Workshop on Empirical Software Engineering in Practice (IWESEP), pp. 49–495. doi:10.1109/IWESEP.49350.2019.00017.
- [35] Weng, J., Weng, J., Zhang, J., Li, M., Zhang, Y., Luo, W., 2019. Deepchain: Auditable and privacy-preserving deep learning with blockchain-based incentive. *IEEE Transactions on Dependable and Secure Computing* , 1–1.
- [36] Xie, C., Koyejo, S., Gupta, I., 2020. Asynchronous federated optimization. *arXiv:1903.03934*.
- [37] Xu, R., Baracaldo, N., Zhou, Y., Anwar, A., Ludwig, H., 2019a. Hybridalpha: An efficient approach for privacy-preserving federated learning, in: *Proceedings of the 12th ACM Workshop on Artificial Intelligence and Security*, Association for Computing Machinery, New York, NY, USA. p. 13–23.
- [38] Xu, Z., Yang, Z., Xiong, J., Yang, J., Chen, X., 2019b. Elfis: Resource-aware federated learning on heterogeneous edge devices. *arXiv:1912.01684*.
- [39] Yang, Q., Liu, Y., Chen, T., Tong, Y., 2019. Federated machine learning: Concept and applications. *ACM Trans. Intell. Syst. Technol.* 10. doi:10.1145/3298981.
- [40] Yokoyama, H., 2019. Machine learning system architectural pattern for improving operational stability, in: 2019 IEEE International Conference on Software Architecture Companion (ICSA-C), pp. 267–274. doi:10.1109/ICSA-C.2019.00055.
- [41] Zhang, W., Lu, Q., Yu, Q., Li, Z., Liu, Y., Lo, S.K., Chen, S., Xu, X., Zhu, L., 2020. Blockchain-based federated learning for device failure detection in industrial iot. *IEEE Internet of Things Journal* , 1–12.