

Optimal Provable Robustness of Quantum Classification via Quantum Hypothesis Testing

Maurice Weber,^{1,*} Nana Liu,^{2,3,4,†} Bo Li,^{5,‡} Ce Zhang,^{1,§} and Zhikuan Zhao^{1,¶}

¹*Department of Computer Science, ETH Zürich, Universitätstrasse 6, 8092 Zürich, Switzerland*

²*Institute of Natural Sciences, Shanghai Jiao Tong University, Shanghai 200240, China*

³*Ministry of Education, Key Laboratory in Scientific and Engineering Computing, Shanghai Jiao Tong University, Shanghai 200240, China*

⁴*University of Michigan-Shanghai Jiao Tong University Joint Institute, Shanghai 200240, China*

⁵*Department of Computer Science, University of Illinois, Urbana, Illinois 61801, USA*

(Dated: November 8, 2021)

Quantum machine learning models have the potential to offer speedups and better predictive accuracy compared to their classical counterparts. However, these quantum algorithms, like their classical counterparts, have been shown to also be vulnerable to input perturbations, in particular for classification problems. These can arise either from noisy implementations or, as a worst-case type of noise, adversarial attacks. These attacks can undermine both the reliability and security of quantum classification algorithms. In order to develop defence mechanisms and to better understand the reliability of these algorithms, it is crucial to understand their robustness properties in presence of both natural noise sources and adversarial manipulation. From the observation that, unlike in the classical setting, measurements involved in quantum classification algorithms are naturally probabilistic, we uncover and formalize a fundamental link between binary quantum hypothesis testing (QHT) and provably robust quantum classification. Then from the optimality of QHT, we prove a robustness condition, which is tight under modest assumptions, and enables us to develop a protocol to certify robustness. Since this robustness condition is a guarantee against the worst-case noise scenarios, our result naturally extends to scenarios in which the noise source is known. Thus we also provide a framework to study the reliability of quantum classification protocols under more general settings.

I. INTRODUCTION

The flourishing interplay between quantum computation and machine learning has inspired a wealth of algorithmic invention in recent years [1–3]. Among the most promising proposals are quantum classification algorithms which aspire to leverage the exponentially large Hilbert space uniquely accessible to quantum algorithms to either drastically speed up computational bottlenecks in classical protocols [4–7], or to construct quantum-enhanced kernels that are practically prohibitive to compute classically [8–10]. Although these quantum classifiers are recognised as having the potential to offer quantum speedup or superior predictive accuracy, they are shown to be just as vulnerable to input perturbations as their classical counter-parts [11–14]. These perturbations can occur either due to imperfect implementation which is prevalent in the noisy, intermediate-scale quantum (NISQ) era [15], or more menacingly due to adversarial attacks where a malicious party aims to fool a classifier by carefully crafting practically undetectable noise patterns which trick a model into misclassifying a given input.

In order to address these short-comings in reliability and security of quantum machine learning, several protocols in the setting of adversarial quantum learning, i.e. learning under the worst-case noise scenario, have been developed [11, 12, 16–18]. More recently, data encoding schemes are linked to ro-

business properties of classifiers with respect to different noise models in Ref. [19]. The connection between provable robustness and quantum differential privacy is investigated in Ref. [17], where naturally occurring noise in quantum systems is leveraged to increase robustness against adversaries. A further step towards robustness guarantees is made in Ref. [18] where an explicit bound is derived from elementary properties of the trace distance. These advances, though having accumulated considerable momentum toward a coherent strategy for protecting quantum machine learning algorithms against adversarial input perturbations, have not yet provided an adequate framework for deriving a tight robustness condition for any given quantum classifier. In other words, the known robustness conditions are sufficient but not, in general, necessary.

Thus a major open problem remains which is significant on both the conceptual and practical levels. Conceptually, adversarial robustness, being an intrinsic property of the classification algorithms under consideration, is only accurately quantified by a tight bound, the absence of which renders the direct robustness comparison between different quantum classifiers implausible. Practically, an optimal robustness certification protocol, in the sense of being capable of faithfully reporting the noise tolerance and resilience of a quantum algorithm can only arise from a robustness condition which is both sufficient and necessary. Here we set to confront both aspects of this open problem by generalising the state-of-the-art classical wisdom on certifiable adversarial robustness into the quantum realm.

The pressing demand for robustness against adversarial attacks is arguably even more self-evident under the classical setting in the present era of wide-spread industrial adaptation of machine learning [13, 14, 20]. Many heuristic defence

*Electronic address: maurice.weber@inf.ethz.ch

†Electronic address: nana.liu@quantumlab.org

‡Electronic address: lbo@illinois.edu

§Electronic address: ce.zhang@inf.ethz.ch

¶Electronic address: zhikuan.zhao@inf.ethz.ch

strategies have been proposed but have subsequently been shown to fail against suitably powerful adversaries [21, 22]. In response, provable defence mechanisms that provide robustness guarantees have been developed. One line of work, interval bound propagation, uses interval arithmetic [23, 24] to certify neural networks. Another approach makes use of randomizing inputs and adopts techniques from differential privacy [25] and, to our particular interest, statistical hypothesis testing [26] which has a natural counter-part in the quantum domain. Since the pioneering works by Helstrom [27] and Holevo [28], the task of quantum hypothesis testing (QHT) has been well-studied and regarded as one of the foundational tasks in quantum information, with profound linkages with topics ranging from quantum communication [29, 30], estimation theory [31], to quantum illumination [32, 33].

In this work, we lay bare a fundamental connection between quantum hypothesis testing and the robustness of quantum classifiers against unknown noise sources and derive a robustness condition with provable tightness under modest assumptions. Based on these theoretical findings, we provide an optimal robustness certification protocol and demonstrate our results with a single-qubit example. We will consider both the deterministic and randomized quantum input settings, the latter of which additionally depicts a quantum generalisation to randomized smoothing, a technique that has recently been applied to certify the robustness of classical machine learning models [26]. The conceptual foundation of our approach is rooted in the inherently probabilistic nature of quantum classifiers. Intuitively, while QHT is concerned with the question of how to optimally discriminate between two given states, certifying adversarial robustness aims at giving a guarantee for which two states can *not* be discriminated. These two seemingly contrasting notions go hand in hand and, as we will see, give rise to optimal robustness conditions fully expressible in the language of QHT. Furthermore, while we focus on robustness in a worst-case scenario, our results naturally cover narrower classes of *known* noise sources and can potentially be put in context with other areas such as error mitigation and error tolerance in NISQ era.

The remainder of this paper is organized as follows: We first introduce the notations and terminologies and review results from QHT essential for our purpose. We then proceed to formally define quantum classifiers and the assumptions on the threat model. In Section II, we present our main results on provable robustness from quantum hypothesis testing. Our findings are then demonstrated and visualised with a simple toy example in Section III, in which we additionally consider the randomized input setting and analyse specifically randomization with depolarization channel. Finally, in Section IV we conclude with a higher-level discussion and layout several related open problems with an outlook for future research.

A. Preliminaries

1. Notations

Let \mathcal{H} be a Hilbert space of finite dimension $d := \dim(\mathcal{H}) < \infty$ corresponding to the quantum system of interest. The space of linear operators acting on \mathcal{H} is denoted by $\mathcal{L}(\mathcal{H})$ and the identity operator on \mathcal{H} is written as $\mathbb{1}$. If not clear from context, the dimensionality is explicitly indicated through the notation $\mathbb{1}_d$. The set of density operators (i.e. positive semi-definite trace-one Hermitian matrices) acting on \mathcal{H} , is denoted by $\mathcal{S}(\mathcal{H})$ and elements of $\mathcal{S}(\mathcal{H})$ are written in lowercase Greek letters. The Dirac notation will be adopted whereby Hilbert space vectors are written as $|\psi\rangle$ and their dual as $\langle\psi|$. We will use the terminology density operator and quantum state interchangeably. For two Hermitian operators $A, B \in \mathcal{L}(\mathcal{H})$ we write $A > B$ ($A \geq B$) if $A - B$ is positive (semi-)definite and $A < B$ ($A \leq B$) if $A - B$ is negative (semi-)definite. For a Hermitian operator $A \in \mathcal{L}(\mathcal{H})$ with spectral decomposition $A = \sum_i \lambda_i P_i$ we write $\{A > 0\} := \sum_{i: \lambda_i > 0} P_i$ (and analogously $\{A < 0\} := \sum_{i: \lambda_i < 0} P_i$) for the projection onto the eigenspace of A associated with positive (negative) eigenvalues. The Hermitian transpose of an operator A is written as A^\dagger and the complex conjugate of a scalar $z \in \mathbb{C}$ as \bar{z} . For two density operators ρ and σ , the trace distance is defined as $T(\rho, \sigma) := \frac{1}{2} \|\rho - \sigma\|_1$ where $\|\cdot\|_1$ is the Schatten 1-norm defined on $\mathcal{L}(\mathcal{H})$ and given by $\|A\|_1 := \text{Tr}[|A|]$ with $|A| = \sqrt{A^\dagger A}$. The fidelity between density operators ρ and σ is denoted by F and defined as $F(\rho, \sigma) := \text{Tr}[\sqrt{\sqrt{\rho}\sigma\sqrt{\rho}}]^2$ which for pure states reduces to the squared overlap $F(|\psi\rangle, |\phi\rangle) = |\langle\psi|\phi\rangle|^2$.

2. Quantum hypothesis testing

Typically, QHT is formulated in terms of state discrimination where several quantum states have to be discriminated through a measurement [27]. In binary quantum hypothesis testing, the aim is to decide whether a given unknown quantum system is in one of two states corresponding to the null and alternative hypothesis. Any such test is represented by an operator $0 \leq M \leq \mathbb{1}_d$, which corresponds to rejecting the null in favor of the alternative. The two central quantities of interest are the probabilities of making a type I or type II error. The former corresponds to rejecting the null when it is true, while the latter occurs if the null is accepted when the alternative is true. Specifically, for density operators $\sigma \in \mathcal{S}(\mathcal{H})$ and $\rho \in \mathcal{S}(\mathcal{H})$ describing the null and alternative hypothesis, the type-I error probability is defined as $\alpha(M)$ and the type-II error probability as $\beta(M)$, so that

$$\alpha(M) := \text{Tr}[\sigma M], \quad \beta(M) := \text{Tr}[\rho(\mathbb{1} - M)]. \quad (1)$$

In *symmetric* hypothesis testing, one is concerned with finding a test which minimizes the total error probability. In the Bayesian setting, one is given prior probabilities π_0 and π_1 corresponding to the probabilities that the system has been

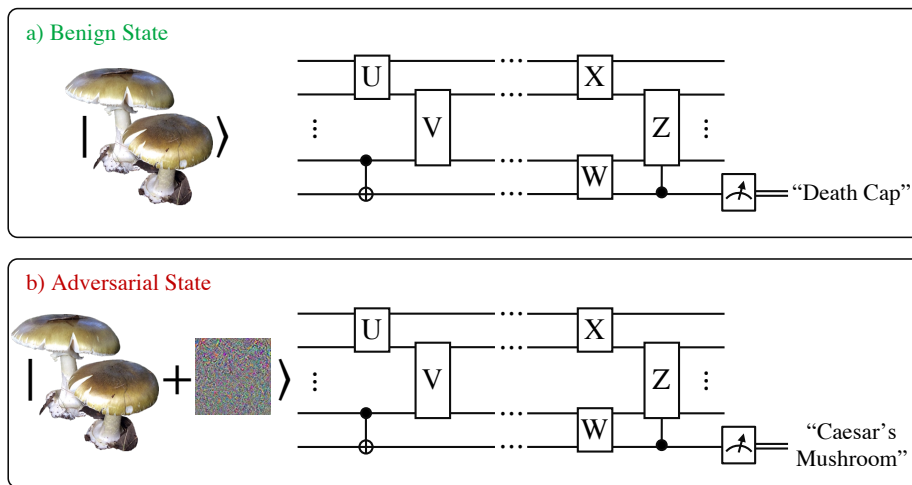

FIG. 1: Schematic illustration of an adversarial attack. A quantum classifier correctly classifies the (highly toxic) mushroom as “death cap” in a). In b), an adversary perturbs the image to fool the classifier into believing the image depicts “Caesar’s mushroom”, which happens to be edible. An adversarial attack of this sort, although not on a quantum computer, has reportedly led to the deaths of Roman Emperor Claudius and Charles VI [34].

prepared either in state σ or ρ . A Bayes optimal test M is one that minimizes the posterior probability $\pi_0 \cdot \alpha(M) + \pi_1 \cdot \beta(M)$.

In this paper, we consider *asymmetric* hypothesis testing, where the two types of errors are associated with a different cost. Given a maximal allowed probability for the type I error, the goal is to minimize the probability of the type II error. Specifically, one aims to solve the constrained optimization problem

$$\inf_{\alpha(M) \leq \alpha_0} \beta(M) \quad (2)$$

where the infimum is taken with respect to all measurement operators $0 \leq M \leq \mathbb{1}_d$ such that the corresponding type-I error falls below the preassigned probability α_0 .

Optimal tests can be expressed in terms of projections onto the eigenspaces of the operator $\rho - t\sigma$ where t is a non-negative number. More specifically, for $t \geq 0$ let $P_{t,+} := \{\rho - t\sigma > 0\}$, $P_{t,-} := \{\rho - t\sigma < 0\}$ and $P_{t,0} := \mathbb{1} - P_{t,+} - P_{t,-}$ be the projections onto the eigenspaces of $\rho - t\sigma$ associated with positive, negative and zero eigenvalues. The quantum analogue to the Neyman-Pearson Lemma [35] shows optimality of operators of the form

$$M_t := P_{t,+} + X_t, \quad 0 \leq X_t \leq P_{t,0}. \quad (3)$$

The choice of the number $t \geq 0$ and the operator X_t is such that the preassigned type-I error probability α_0 is attained. An explicit construction for these operators is based on the inequalities

$$\alpha(P_{\tau(\alpha_0),+}) \leq \alpha_0 \leq \alpha(P_{\tau(\alpha_0),+} + P_{\tau(\alpha_0),0}) \quad (4)$$

where $\alpha_0 \in (0, 1)$ and $\tau(\alpha_0)$ is the smallest non-negative number such that $\alpha(P_{\tau(\alpha_0),+}) \leq \alpha_0$, i.e. $\tau(\alpha_0) := \inf\{t \geq 0: \alpha(P_{t,+}) \leq \alpha_0\}$. These inequalities are justified by the observation that the function $t \mapsto \alpha(P_{t,+})$ is non-increasing and

right-continuous while $t \mapsto \alpha(P_{t,+} + P_{t,0})$ is non-increasing and left-continuous. A detailed proof for this may be found in the supplementary materials, Section A 2. We will henceforth refer to operators of the form (3) as Helstrom operators [31].

3. Quantum classifiers

We define a K -class quantum classifier of states of the quantum system \mathcal{H} described by density operators as a map $\mathcal{A}: \mathcal{S}(\mathcal{H}) \mapsto \mathcal{C}$ which maps states $\sigma \in \mathcal{S}(\mathcal{H})$ to class labels $k \in \mathcal{C} = \{1, \dots, K\}$. Given a quantum state σ , we identify the probability of measuring outcome k to be the class probability

$$\sigma \mapsto \mathbf{y}_k(\sigma) \equiv \text{Tr}[\Pi_k \mathcal{E}(\sigma)] \quad (5)$$

where \mathcal{E} is a quantum operation acting on the input state which mathematically corresponds to a completely positive trace-preserving (CPTP) map. We treat the positive-operator valued measure (POVM) element Π_k as a projector $\Pi_k = |k\rangle\langle k| \otimes \mathbb{1}_{d/K}$ which determines whether the output is classified into class k . This can be done without loss of generality by Naimark’s dilation since \mathcal{E} is kept arbitrary and potentially involves ancillary qubits and a general POVM element can be expressed as a projector on the larger Hilbert space. The final prediction is given by the most likely class

$$\mathcal{A}(\sigma) \equiv \arg \max_k \mathbf{y}_k(\sigma). \quad (6)$$

In the context of quantum machine learning, the input state σ can be an encoding of classical data by means of, for example, amplitude encoding or otherwise [19, 36], or inherently quantum input data, while \mathcal{E} can be realized, for example, by a trained parametrized quantum circuit potentially involving ancillary registers [37]. However, it is worth noting that the

above-defined notion of quantum classifier more generally describes the procedure of a broader class of quantum algorithms whose output is obtained by repeated sampling of measurement outcomes.

4. Quantum adversarial robustness

Adversarial examples are attacks on classification models where an adversary aims to induce a misclassification using typically imperceptible modifications of a benign input example. Specifically, given a classifier \mathcal{A} and a benign input state σ , an adversary can craft a small perturbation $\sigma \rightarrow \rho$ which results in a misclassification, i.e. $\mathcal{A}(\rho) \neq \mathcal{A}(\sigma)$. An illustration for this threat scenario is given in FIG. 1. In this paper, we seek a worst-case robustness guarantee against *any* possible attack: as long as ρ does not differ from σ by more than a certain amount, then it is guaranteed that $\mathcal{A}(\sigma) = \mathcal{A}(\rho)$ independently of how the adversarial state ρ has been crafted. Formally, suppose the quantum classifier \mathcal{A} takes as input a *benign* quantum state $\sigma \in \mathcal{S}(\mathcal{H})$ and produces a measurement outcome denoted by the class $k \in \mathcal{C}$ with probability $\mathbf{y}_k(\sigma) = \text{Tr}[\Pi_k \mathcal{E}(\sigma)]$. Recall that the prediction of \mathcal{A} is taken to be the most likely class $k_A = \arg \max_k \mathbf{y}_k(\sigma)$. An adversary aims to alter the output probability distribution so as to change the most likely class by applying an arbitrary quantum operation $\mathcal{E}_A: \mathcal{S}(\mathcal{H}) \rightarrow \mathcal{S}(\mathcal{H})$ to σ resulting in the *adversarial state* $\rho = \mathcal{E}_A(\sigma)$. Finally, we say that the classifier \mathbf{y} is provably robust around σ with respect to the robustness condition \mathcal{R} , if for any ρ which satisfies \mathcal{R} , it is guaranteed that $\arg \max_k \mathbf{y}_k(\rho) = \arg \max_k \mathbf{y}_k(\sigma)$. Typically, \mathcal{R} is expressed explicitly in terms of trace distance or fidelity. However, as we shall see, it is also possible to formulate a condition in terms of optimal type-II error probabilities which is not always easily expressible with other distance measures. Furthermore, we note that while we are interested in robustness conditions on quantum states, the assumption that an adversary can only act on quantum states is not needed for our results to hold.

B. Summary of results

In this work, we establish a fundamental connection between QHT and the robustness of quantum classification algorithms against adversarial input perturbations and derive a robustness condition in terms of the errors of the optimal tests to distinguish between the benign and adversarial states (QHT condition: Theorem 1). Under certain practical assumptions about the class probabilities on benign input, we prove that the QHT condition is optimal (Theorem 2). We then show the QHT condition, implicitly written in terms of the type-II errors of optimal hypothesis tests at a preassigned type-I error probability, implies explicit robustness bounds in the form of trace distances in the settings of pure benign and adversarial states (Corollary 1), as well as pure benign and mixed adversarial states (Corollary 2). We numerically compare an alternative robustness bound directly implied by the definition

of trace distance and application of Hölder duality (Lemma 1 & Ref. [18]) with the explicit forms of the robustness bounds arising from QHT (FIG. 2). Based on these technical findings. We then provide a practical protocol for robustness certification of quantum classifiers (Protocol 1). Finally, we instantiate our results with a single-qubit pure state example both in the deterministic (without randomizing inputs) and depolarization smoothing input scenarios, which allows for numerical comparison of all the known robustness bounds, arising from Hölder duality, differential privacy [17] and QHT (FIG. 4). The technical results of our work and the state-of-the-art of certifiable adversarial robustness of quantum classifiers are summarized in TABLE I.

II. PROVABLY ROBUST QUANTUM CLASSIFICATION WITH QUANTUM HYPOTHESIS TESTING

In this section, we present our main results. We will derive a robustness condition for quantum classifiers with the QHT formalism, which provides a provable guarantee for the outcome of a computation being unaffected by the worst-case input noise or perturbation under a given set of constraints. In the regime where the most likely class is measured with probability lower bounded by $p_A > 1/2$ and the runner up class is not more likely than $p_B = 1 - p_A$, we prove tightness of the robustness bound, hence demonstrating that the QHT condition is at least partially optimal. The QHT robustness condition, in its full generality, has an implicit form in terms of the type-II error probabilities of the Helstrom measurement. We simplify this condition and derive its explicit forms in terms of the trace distance between benign and adversarial inputs. In the scenarios of both input being pure states, the explicit bound is equivalent to the implicit bound, and is hence provably tight when $p_A + p_B = 1$. In the scenarios of pure benign and mixed adversarial inputs, the explicit robustness bound occurs to be weaker. These results stemming from QHT considerations are then contrasted and compared with an alternative approach which directly applies Hölder duality to trace distances to obtain a sufficient robustness condition.

A. Robustness condition from quantum hypothesis testing

Recall that quantum hypothesis testing is concerned with the question of finding measurements that optimally discriminate between two states. A measurement is said to be optimal if it minimizes the probabilities of identifying the quantum system to be in the state σ , corresponding to the null hypothesis, when in fact it is in the alternative state ρ , and vice versa. When considering provable robustness, on the other hand, one aims to find a neighbourhood around a benign state σ where the class which is most likely to be measured is constant or, expressed differently, where the classifier can not discriminate between states. It becomes thus clear that quantum hypothesis testing and classification robustness aim to achieve a similar goal, although viewed from different angles. Indeed, as it turns out, QHT determines the robust region around σ to

TABLE I: Summary of Results. Tightness in the regime where predicted class probabilities satisfy $p_A + p_B = 1$ implied by Theorem 2 is indicated by \dagger .

	Input States (Benign-Adversarial)	Quantum Differential Privacy	Hölder Duality	Quantum Hypothesis Testing	
				Implicit ^a	Explicit ^b
No Smoothing	Pure-Pure	—	Lemma 1 ^c	Theorem 1 [†]	Corollary 1 [†]
	Pure-Mixed				Corollary 2
Depolarization Smoothing	Pure-Pure	Lemma 2 in Ref. [17]	Eq. (32)	Theorem 1 [†]	Eq. (30) (single-qubit) [†]
	Pure-Mixed				—

^a Robustness condition expressed in terms of type-II error probabilities β associated with an optimal quantum hypothesis test.

^b Robustness condition expressed in terms of trace distance $T(\rho, \sigma)$.

^c Independently discovered in Ref. [18].

be the point where the optimal discriminator has type-II error $> 1/2$.

To establish this connection more formally, we identify the benign state with the null hypothesis σ and the adversarial state with the alternative ρ . We note that, in the Heisenberg picture, we can identify a classifier \mathbf{y} with a POVM $\{\Pi_k\}_k$. Additionally, let k_A be the class of σ predicted by \mathbf{y} , i.e. $k_A = \arg \max_k \text{Tr}[\Pi_k \sigma]$. With this, the measurement $\mathbb{1} - \Pi_{k_A}$ (and thus the classifier \mathbf{y}) can be viewed as a hypothesis test discriminating between σ and ρ . Given a lower bound $p_A \leq \text{Tr}[\Pi_{k_A} \sigma]$, asymmetric quantum hypothesis testing delivers an optimal test M_A^* which has type-I error $\alpha(M_A^*) = 1 - p_A$. Crucially, optimality implies that M_A^* minimizes the type-II error probability among all tests with type-I error probability at most $1 - p_A$ and thus, in particular $\mathbf{y}_{k_A}(\rho) = \beta(\mathbb{1} - \Pi_{k_A}) \geq \beta(M_A^*)$. Clearly, if $\beta(M_A^*) > 1/2$, then it is guaranteed that k_A is the class of ρ that is most likely to be predicted by \mathbf{y} . The following theorem makes this reasoning concise and extends to the setting where additionally the probability of measuring the second most likely class is bounded from above by p_B .

Theorem 1 (QHT robustness bound). *Let $\sigma, \rho \in \mathcal{S}(\mathcal{H})$ be benign and adversarial quantum states and let \mathbf{y} be a quantum classifier. Suppose that for $k_A \in \mathcal{C}$ and $p_A, p_B \in [0, 1]$ the classifier \mathbf{y} predicts class probabilities*

$$\mathbf{y}_{k_A}(\sigma) \geq p_A > p_B \geq \max_{k \neq k_A} \mathbf{y}_k(\sigma). \quad (7)$$

Let M_A^ and M_B^* be Helstrom operators for testing the null σ against the alternative ρ with type-I error probabilities $\alpha(M_A^*) = 1 - p_A$ and $\alpha(M_B^*) = p_B$. Then, if the type-II error probabilities satisfy*

$$\beta(M_A^*) + \beta(M_B^*) > 1 \quad (8)$$

it is guaranteed that $k_A = \arg \max_k \mathbf{y}_k(\rho)$, i.e. $\mathbf{y}_{k_A}(\rho) > \max_{k \neq k_A} \mathbf{y}_k(\rho)$.

Proof (sketch). Here we provide the central intuitions governing the proof of our result and refer the reader to the supplementary materials for details. Recall that $\beta(M) := \text{Tr}[\rho(\mathbb{1} - M)]$. We first note that any classifier of the form (5) can be written in the Heisenberg picture as $\mathbf{y}_k(\sigma) = \text{Tr}[\Pi_k \sigma]$

where $\{\Pi_k\}_k$ is a POVM. Since, in particular it holds that $0 \leq \Pi_k \leq \mathbb{1}$ for any k , the measurement defined by $\{\Pi_{k_A}, \mathbb{1} - \Pi_{k_A}\}$ can thus be viewed as a quantum hypothesis test. One then shows that for an operator $0 \leq M \leq \mathbb{1}$ and a Helstrom operator M_t we have

$$\alpha(M) \geq 1 - \alpha(M_t) \Rightarrow 1 - \beta(M) \geq \beta(M_t). \quad (9)$$

Setting $M = \Pi_{k_A}$, $M_t = M_A^*$ and using the fact that $\alpha(M_A^*) = 1 - p_A$ yields the inequality $\alpha(\Pi_{k_A}) = \mathbf{y}_{k_A}(\sigma) \geq p_A = 1 - \alpha(M_A^*)$ and thus

$$\mathbf{y}_{k_A}(\rho) = 1 - \beta(\Pi_{k_A}) \geq \beta(M_A^*). \quad (10)$$

In a similar way, it is shown that for any $k \neq k_A$ we have $\mathbf{y}_k(\rho) \leq 1 - \beta(M_B^*)$. Robustness is thus guaranteed as long as $1 - \beta(M_B^*) < \beta(M_A^*)$. \square

To get some more intuition of Theorem 1, we first note that for $p_B = 1 - p_A$, the robustness condition (8) simplifies to

$$\beta(M_A^*) > 1/2. \quad (11)$$

With this, the relation between quantum hypothesis testing and robustness becomes more evident: if the *optimal* hypothesis test on average fails to distinguish the two states, then a classifier will predict both states to belong to the same class. In other words, viewing a classifier as a hypothesis test between the benign input σ and the adversarial ρ , the optimality of the Helstrom operators implies that the classifier \mathbf{y} is a worse discriminator and will also not distinguish the states, or, phrased differently, it is robust. This result formalizes the intuitive connection between quantum hypothesis testing and robustness properties of quantum classifiers. While the former is concerned with finding operators that are optimal with respect to discriminating two states, the latter is concerned with finding conditions on states for which a classifier does *not* discriminate.

B. Optimality

The robustness condition (8) from QHT is provably optimal in the regime of $p_A + p_B = 1$, which covers binary classifications in full generality and multi-class classification where

the most likely class is measured with probability larger than $p_A > \frac{1}{2}$. The robustness bound is tight in the sense that there exists a classifier \mathbf{y}^* consistent with class probabilities on the benign input but will classify the adversarial input incorrectly if the condition (8) is violated. The following theorem demonstrates this notion of tightness by explicitly constructing the "worst-case" classifier.

Theorem 2 (QHT Robustness Condition Tightness). *Given $p_A + p_B = 1$, if the adversarial state ρ violates condition (8), there exists a quantum classifier \mathbf{y}^* that is consistent with the class probabilities (7) and for which $\arg \max_k \mathbf{y}_k^*(\rho) \neq \arg \max_k \mathbf{y}_k^*(\sigma)$.*

Proof. Since $p_A + p_B = 1$, we have $M_A^* = M_B^*$. For $k_B \neq k_A$, consider the operators $\Pi_{k_A} := \mathbb{1} - M_A^*$, $\Pi_{k_B} := M_A^*$, and $\Pi_{k \neq k_A, k_B} = 0$. Since $0 \leq M_{1-p_A}^* \leq \mathbb{1}$, it follows that $\Pi_k \geq 0$ for all k . It is clear that $\sum_k \Pi_k = \mathbb{1}$. The set of operators $\{\Pi_k\}_k$ is thus a POVM and we can define the classifier

$$\mathcal{S}(\mathcal{H}) \ni \sigma' \mapsto \mathbf{y}_k^*(\sigma') = \text{Tr}[\sigma' \Pi_k] \quad \forall k = 1, \dots, K. \quad (12)$$

Note that \mathbf{y}^* is consistent with the class probabilities p_A, p_B since $\mathbf{y}_{k_A}^*(\sigma) = \text{Tr}[\sigma(\mathbb{1} - M_A^*)] = p_A \geq p_B$ and $p_B = \alpha(M_A^*) = \mathbf{y}_{k_B}^*(\sigma) = \max_{k \neq k_A} \mathbf{y}_k^*(\sigma)$. On the other hand, if the robustness condition is violated, we have $\beta(M_A^*) < 1 - \beta(M_B^*) \iff \text{Tr}[\rho(\mathbb{1} - M_A^*)] < \text{Tr}[\rho M_A^*] \iff \mathbf{y}_{k_A}^*(\rho) < \mathbf{y}_{k_B}^*(\rho)$, thus $\arg \max_k \mathbf{y}_k^*(\rho) \neq k_A$. \square

Whether or not the QHT robustness condition is tight for $p_A + p_B < 1$ is an interesting open question for future research. It turns out that a worst-case classifier that is consistent with p_A and p_B for benign input but leads to misclassification on adversarial input upon violating condition (8), if exists, is more challenging to construct for these cases. If such a tightness for all class probabilities regime would be proven, there would be a complete characterization for the robustness of quantum classifiers. On the other hand, a negative result would mean that robustness bounds based on statistical hypothesis testing can be improved for quantum classifiers in the regime of $p_A + p_B < 1$ but is generally tight for classical classifiers, which would reveal an intriguing quantum distinction from its classical counterpart, and that, albeit in a somewhat contrived sense, quantum classifiers could be more robust than classical ones in these regimes.

C. Robustness bounds in terms of trace distance

1. QHT robustness bounds

Although Theorem 1 provides a general condition for robustness with provable tightness, it is formulated somewhat implicitly in terms of type-II error probabilities of QHT. To gain a more intuitive and operationally convenient perspective, we wish to derive a condition for robustness in terms of the canonical measure of the difference between quantum states, namely the trace distance between σ and ρ . Assuming that the benign and adversarial states are both pure states, an

explicit robustness condition in terms of the trace distance can be derived as a corollary of Theorem 1.

Corollary 1 (Pure Benign & Pure Adversarial States). *If σ and ρ are pure states then the robustness condition (8) is equivalent to*

$$T(\rho, \sigma) < \sqrt{\frac{1 - f(p_A, p_B)}{2}} \quad (13)$$

where $T(\rho, \sigma) = \frac{1}{2} \|\rho - \sigma\|_1$ is the trace distance between the benign and adversarial states, and

$$f(p_A, p_B) = \left\{ 1 - p_B - p_A(1 - 2p_B) + 2\sqrt{p_A p_B(1 - p_A)(1 - p_B)} \right\}^{\frac{1}{2}} \quad (14)$$

Proof (sketch). Here we present a sketch of the main proof idea and refer the reader to the supplementary materials for details. The key challenge to proving this Corollary is connecting the robustness condition (8), written in terms of type-II error probabilities, to the trace distance $T(\rho, \sigma)$ between ρ and σ . The first step is then to solve the eigenvalue problem

$$(\rho - t\sigma)|\eta\rangle = \eta|\eta\rangle \quad (15)$$

which, for pure states, can be expressed in terms of the fidelity $F(\rho, \sigma)$ between ρ and σ . Given these solutions, one then derives an expression for the Helstrom operators M_A^* and M_B^* . This leads to the condition $\beta(M_A^*) + \beta(M_B^*) > 1$ being an inequality which can be solved explicitly for the fidelity. Finally, since for pure states the Fuchs-van de Graaf inequalities yields an equality, the fidelity is related to the trace distance with $T(\rho, \sigma) = \sqrt{1 - F(\rho, \sigma)}$. The derived condition on the fidelity can hence be written as a bound in the trace distance which has the form (13). \square

The robustness condition (13) in the above is both sufficient and necessary (in the regime of $p_A + p_B = 1$), as it is exactly equivalent to Theorem 1 for pure benign and adversarial states. In the following Corollary, we generalise the tight, explicit robustness condition for pure states to derive a sufficient robustness condition for cases where adversarial states are allowed to be mixed:

Corollary 2 (Pure Benign & Mixed Adversarial States). *If $\sigma = |\sigma\rangle\langle\sigma|$ is a pure state but ρ can be a mixed state, then the robustness condition (8) implies the following sufficient condition for robustness, i.e. $k_A = \arg \max_k \mathbf{y}_k(\rho)$:*

$$T(\rho, \sigma) < \delta(p_A, p_B) \left(1 - \sqrt{1 - \delta(p_A, p_B)^2} \right), \quad (16)$$

where $\delta(p_A, p_B) = \sqrt{\frac{1 - f(p_A, p_B)}{2}}$.

Proof. See Supplementary Materials. \square

Intuitively, condition (16) is derived by noting that any convex mixture of robust pure states must also be robust, thus membership of the set of mixed states enclosed by the convex hull of robust pure states (certified by Corollary 1) is a natural sufficient condition for robustness. As such, the corresponding robustness radius in condition (16) is obtained by lower-bounding, with triangle inequalities, the radius of the maximal sphere centered at σ within the convex hull. However, the generalization from Corollary 1 to Corollary 2, mediated by the above geometrical argument, results in a sacrifice of tightness. How or to what extent such loosening of the explicit bound in the cases of mixed states may be avoided or ameliorated remains an open question. In the following, we compare both explicit bounds from QHT with a robustness condition derived from an entirely different technique.

2. Hölder duality robustness bound

We note that a sufficient condition can be obtained from a somewhat straightforward application of Hölder duality for trace norms:

Lemma 1 (Hölder duality bound). *Let $\sigma, \rho \in \mathcal{S}(\mathcal{H})$ be arbitrary quantum states. If the trace distance of ρ and σ is bounded by*

$$\frac{1}{2} \|\rho - \sigma\|_1 < \frac{p_A - p_B}{2} \quad (17)$$

where p_A and p_B are bounds to the class probabilities that satisfy $\mathbf{y}_{k_A}(\sigma) \geq p_A > p_B \geq \max_{k \neq k_A} \mathbf{y}_k(\sigma)$, then we have that

$$\mathbf{y}_{k_A}(\rho) > \max_{k \neq k_A} \mathbf{y}_k(\rho). \quad (18)$$

Proof. Let $\delta := \frac{1}{2} \|\rho - \sigma\|_1 = \sup_{0 \leq P \leq \mathbb{I}} \text{Tr}[P(\rho - \sigma)]$, which follows from Hölder duality. We have that $\mathbf{y}_{k_A}(\sigma) - \mathbf{y}_{k_A}(\rho) \leq \delta$ and that $\mathbf{y}_{k_A}(\sigma) \geq p_A$, hence $\mathbf{y}_{k_A}(\rho) \geq p_A - \delta$. We also have, for k' such that $\mathbf{y}_{k'}(\rho) = \max_{k \neq k_A} \mathbf{y}_k(\rho)$, that $\mathbf{y}_{k'}(\rho) - \mathbf{y}_{k'}(\sigma) \leq \delta$ and that $\mathbf{y}_{k'}(\sigma) \leq p_B$, hence $\max_{k \neq k_A} \mathbf{y}_k(\rho) \leq p_B + \delta$. Thus $\frac{1}{2} \|\rho - \sigma\|_1 < \frac{p_A - p_B}{2} \iff p_A - \delta > p_B + \delta \implies \mathbf{y}_{k_A}(\rho) > \max_{k \neq k_A} \mathbf{y}_k(\rho)$. \square

We acknowledge the above robustness bound from Hölder duality was independently discovered in Lemma 1 of Ref. [18]. For intuitive insights, it is worth remarking that the condition (17) stems from comparing the maximum probability of distinguishing σ and ρ with the optimal measurement (Hölder measurement) with the gap between the first two class probabilities on σ . Since no classifier can distinguish σ and ρ better than the Hölder measurement by definition, (17) is clearly a sufficient condition. However, the Hölder measurement on σ does not necessarily result in class probabilities consistent with eq. (7). Without additional constraints on desired class probabilities on the benign input, the robustness condition (17) from Hölder duality is stronger than necessary. In contrast, the QHT bound from Theorem 1, albeit implicitly written in the language of hypothesis testing, naturally incorporates such desired constraints. Hence this gives rise to a

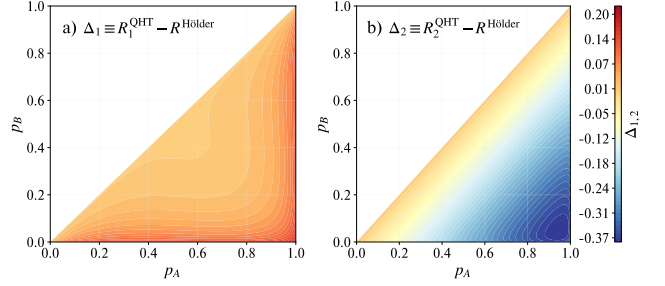

FIG. 2: Comparison between robustness bounds in terms of trace distance. Figure a) depicts the difference $R_1^{\text{QHT}} - R^{\text{Hölder}}$ between the pure state bound derived from QHT and presented in Corollary 1 and the Hölder duality bound from Lemma 1. Figure b) shows the difference $R^{\text{Hölder}} - R_2^{\text{QHT}}$ between the Hölder duality bound derived from the convex hull approximation to the QHT robustness condition from Theorem 1 for mixed adversarial states. It can be seen that the pure state bound R_1^{QHT} is always larger than $R^{\text{Hölder}}$ which in turn is always larger than the convex hull approximation bound R_2^{QHT} .

tighter robustness condition as expected. Explicitly in terms of trace distances, the tightness of Theorem 1 is completely inherited from Corollary 1, for the case of pure state inputs but partially lost in Corollary 2, for the case of pure benign and mixed adversarial input. The numerical comparison between the explicit forms of the QHT bound (in terms of trace distances) and the Hölder duality bound is shown in a contour plot in FIG 2.

D. Robustness certification protocol

Certifying the robustness of a quantum classifier \mathbf{y} around a benign input state σ requires one to (1) identify the most likely class k_A , and (2) in the finite sampling regime, one has to estimate a lower bound p_A on the most likely class probability and an upper bound p_B on the probability of the second most likely class.

Specifically, given an error tolerance ε , one samples the quantum circuit N times to obtain the estimates

$$\begin{aligned} p_A &= \hat{\mathbf{y}}_{k_A}^{(N)}(\sigma) - \sqrt{\frac{-\log(\varepsilon)}{2N}}, \\ p_B &= \hat{\mathbf{y}}_{k_B}^{(N)}(\sigma) + \sqrt{\frac{-\log(\varepsilon)}{2N}}. \end{aligned} \quad (19)$$

Hoeffding's inequality then implies that with probability $1 - \varepsilon$ the true class scores $\mathbf{y}_{k_A}(\sigma)$ and $\mathbf{y}_{k_B}(\sigma)$ are lower and upper bounded by p_A and p_B . The procedure to obtain a robustness certificate for \mathbf{y} around a pure input σ is presented in Protocol 1. The version presented here only certifies input states σ for which we have $p_A > 1/2$ so that we can set $p_B = 1 - p_A$. However, this procedure is easily extended to the general setting. With the same procedure it is also possible to obtain certificates for mixed adversarial states by employing the Hölder duality bound from Lemma 1.

Protocol 1 Robustness Certification($\sigma, N, \varepsilon, \mathcal{A}$)

Input: Pure quantum state $\sigma \in \mathcal{S}(\mathcal{H})$, number of measurement shots N , error tolerance ε , a quantum classifier $\mathcal{A} = (\mathcal{E}, \{\Pi_k\}_{k \in \mathcal{C}})$.

Output: Predicted class k_A , prediction score p_A and robust radius R_1^{QHT} in trace distance.

- 1: Set counter $\mathbf{n}_k = 0$ for every $k \in \mathcal{C}$.
 - 2: **for** $k = 1, \dots, N$ **do**
 - 3: Apply quantum circuit \mathcal{E} to initial state σ .
 - 4: Perform $|\mathcal{C}|$ -outcome measurement $\{\Pi_k\}_{k \in \mathcal{C}}$ on the evolved state $\mathcal{E}(\sigma)$.
 - 5: Record measurement outcome k by setting $\mathbf{n}_k \leftarrow \mathbf{n}_k + 1$.
 - 6: **end for**
 - 7: Calculate empirical probability distribution $\hat{\mathbf{y}}_k^{(N)} = \mathbf{n}_k N^{-1}$.
 - 8: Extract the most likely class $k_A = \arg \max_k \hat{\mathbf{y}}_k^{(N)}$.
 - 9: Set $p_A = \hat{\mathbf{y}}_{k_A}^{(N)}(\sigma) - \sqrt{\frac{-\log(\varepsilon)}{2N}}$.
 - 10: **if** $p_A > 1/2$ **then**
 - 11: Calculate robust radius $R_1^{\text{QHT}} = \sqrt{\frac{1}{2} - \sqrt{p_A(1-p_A)}}$.
 - 12: **return** prediction k_A , class score p_A , robust radius R_1^{QHT} .
 - 13: **else**
 - 14: **return** ABSTAIN
 - 15: **end if**
-

III. TOY EXAMPLE & RANDOMIZED INPUTS

A. Toy example with single-qubit pure states

We now present a simple example to highlight the connection between quantum hypothesis testing and classification robustness. We consider a single-qubit system which is prepared either in the state σ or ρ described by

$$|\sigma\rangle = |0\rangle, \quad |\rho\rangle = \cos(\theta_0/2) |0\rangle + \sin(\theta_0/2) e^{i\phi_0} |1\rangle \quad (20)$$

with $\theta_0 \in [0, \pi)$ and $\phi_0 \in [0, 2\pi)$. The state σ corresponds to the null hypothesis in the QHT setting and to the benign state in the classification setting. Similarly, ρ corresponds to the alternative hypothesis and adversarial state. The operators which are central to both QHT and robustness are the Helstrom operators (3) which are derived from the projection operators onto the eigenspaces associated with the non-negative eigenvalues of the operator $\rho - t\sigma$. For this example, the eigenvalues are functions of $t \geq 0$ and given by

$$\begin{aligned} \eta_1 &= \frac{1}{2}(1-t) + R > 0, & \eta_2 &= \frac{1}{2}(1-t) - R \leq 0 \\ R &= \frac{1}{2} \sqrt{(1-t)^2 + 4t(1-|\gamma|^2)} \end{aligned} \quad (21)$$

where γ is the overlap between σ and ρ and given by $\gamma = \cos(\theta_0/2)$. For $t > 0$, the Helstrom operators are then given by the projection onto the eigenspace associated with the eigenvalue $\eta_1 > 0$. The projection operator is given by $M_t = |\eta_1\rangle\langle\eta_1|$ with

$$\begin{aligned} |\eta_1\rangle &= (1-\eta_1)A_1|0\rangle - \gamma A_1|\rho\rangle \\ |A_1|^{-2} &= 2R|\eta_1 - \sin^2(\theta_0/2)| \end{aligned} \quad (22)$$

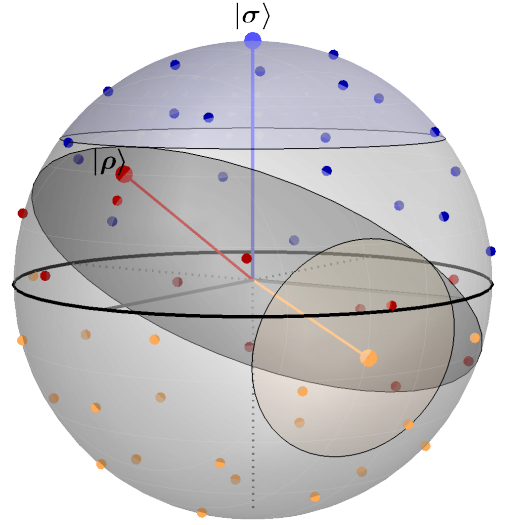

FIG. 3: Example classifier for single-qubit quantum states. The decision boundary is represented by the grey disk passing through the origin of the Bloch sphere. Robust regions are indicated by the blue and orange spherical caps. Blue (orange) states correspond to class-0 (class-1) data points which are correctly classified, while red states are misclassified. For the given classifier, the state ρ is not contained in the robust region around σ and is thus not guaranteed to be classified correctly by every classifier with the same class probabilities. In the asymmetric hypothesis testing view, an optimal discriminator for testing σ against ρ and which admits 0.1 type-I error probability has type-II error probability 0.44.

where A_1 is normalization constant ensuring that $\langle\eta_1|\eta_1\rangle = 1$. Given a preassigned probability α_0 for the maximal allowed type-I error probability, we determine t such that $\alpha(M_t) = \alpha(|\eta_1\rangle\langle\eta_1|) = \alpha_0$ is satisfied.

1. Hypothesis testing view

In QHT we are given a specific alternative hypothesis ρ and error probability α_0 and are interested in finding the minimal type-II error probability. In this example, we pick $\theta_0 = \pi/3$, $\phi_0 = -\pi/2$ and set the type-I error probability to $\alpha_0 = 1 - p_A = 0.1$. For this choice of states, we obtain an expression for the eigenvector $|\eta_1\rangle$ given by

$$|\eta_1\rangle = \frac{9 - \sqrt{3}}{\sqrt{30}} |0\rangle - 3\sqrt{\frac{2}{5}} |\rho\rangle. \quad (23)$$

which yields the type-II error probability

$$\beta(M_t) = 1 - |\langle\eta_1|\rho\rangle|^2 \approx 0.44 < 1/2. \quad (24)$$

We thus see that the optimal hypothesis test can discriminate σ and ρ with error probabilities less than 1/2 since on the Bloch sphere they are located far enough apart. However, since $\beta(M_t) \not\approx 1/2$, Theorem 1 implies that ρ is not guaranteed to be classified equally as σ by a classifier which makes a prediction on σ with confidence at least 0.9. In other words,

the two states are far enough apart to be easily discriminated by the optimal hypothesis test but too far apart to be guaranteed to be robust.

2. Classification robustness view

In this scenario, in contrast to the QHT view, we are not given a specific adversarial state ρ , but rather wish to find a condition on ρ such that the classifier is robust for all ρ that satisfy this condition. Theorems 1 and 2 provide a necessary and sufficient condition for robustness, expressed in terms of β , which reads

$$\beta(M_A^*) > 1/2 \quad (25)$$

where M_A^* is a Helstrom operator with $\alpha(M_A^*) = 1 - p_A$ and $p_A > 1/2$ is a lower bound to the probability of the most likely class. For example, as the QHT view shows, for $\alpha_0 = 1 - p_A = 0.1$ we have that $\beta \approx 0.44 < 1/2$ for a state ρ with $\theta_0 = \pi/3$. We thus see that it is not guaranteed that every quantum classifier, which predicts σ to be of class k_A with probability 0.9, classifies ρ to be of the same class. We would now like to find the maximum θ_0 , for which every classifier with confidence greater than p_A is guaranteed to classify ρ and σ equally. Since both states are pure, we can use the condition on the fidelity—which is equivalent to $\beta(M_A^*) > 1/2$ —and obtain a bound on θ_0 so that

$$\begin{aligned} |\langle \rho | \sigma \rangle| &= \cos^2(\theta_0/2) > \frac{1}{2} + \sqrt{p_A(1-p_A)} \\ \iff \theta_0 &< 2 \cdot \arccos \sqrt{\frac{1}{2} + \sqrt{p_A(1-p_A)}}. \end{aligned} \quad (26)$$

In particular, if $p_A = 0.9$, we find that angles $\theta_0 < 2 \cdot \arccos(\sqrt{0.8}) \approx 0.93 < \pi/3$ are certified. Figure 3 illustrates this scenario: the blue region around σ contains all states for which any classifier with confidence at least 0.9 will make a prediction consistent with σ .

3. Classifier example

We consider a binary quantum classifier \mathbf{y} which discriminates single-qubit states living on the upper (class 0) and lower (class 1) hemispheres of the Bloch sphere. Specifically, we consider the POVM $\{\Pi_{\theta,\phi}, \mathbb{1}_2 - \Pi_{\theta,\phi}\}$ defined by the projection operator $\Pi_{\theta,\phi} = |\psi_{\theta,\phi}\rangle\langle\psi_{\theta,\phi}|$ where

$$|\psi_{\theta,\phi}\rangle := \cos(\theta/2) |0\rangle + \sin(\theta/2) e^{i\phi} |1\rangle \quad (27)$$

with $\theta = 2 \cdot \arccos(\sqrt{0.9}) \approx 0.644$ and $\phi = \pi/2$. Furthermore, for the rest of this section, we assume that $p_A + p_B = 1$ so that p_B is determined by p_A via $p_B = 1 - p_A$. An illustration of this classification problem is given in Figure 3, where the decision boundary of \mathbf{y} is represented by the grey disk crossing the origin of the Bloch sphere. The blue states correspond to class-0 states which have been classified correctly, orange states correspond to data points correctly classified as 1

and red states are misclassified by \mathbf{y} . It can be seen that, since the state ρ has been shown to violate the robustness condition (i.e. $\beta(M_A^*) \approx 0.44 < 1/2$), it is not guaranteed to be classified ρ and σ equally. In particular, the classifier \mathbf{y} misclassifies ρ .

In summary, as $p_A \rightarrow \frac{1}{2}$, the robust radius approaches 0. In the QHT view, this can be interpreted in the sense that if the type-I error probability α_0 approaches $1/2$, then all alternative states can be discriminated from σ with type-II error probability less than $1/2$. As $p_A \rightarrow 1$, the robust radius approaches $\pi/2$. In this regime, the QHT view says that if the type-I error probability α_0 approaches 0, then the corresponding Helstrom operator will admit a type-II error probability smaller than $1/2$ only for states in the lower half of the Bloch sphere.

B. Randomized inputs with depolarization smoothing

Here we briefly discuss randomized input scenarios, led by the intuition that noise can be exploited to increase robustness and privacy. We first provide background on randomized smoothing, a technique for provable robustness from classical machine learning. We then proceed to present provable robustness in terms of trace distance which is equivalent to the robustness condition (8) from Theorem 1 but with randomized inputs. The bound is then compared numerically with the Hölder duality bound from Lemma 1 and with a result obtained recently from quantum differential privacy [17].

1. Background: randomized smoothing

Randomized Smoothing is a technique that has recently been proposed to certify the robustness and obtains tight provable robustness guarantees in the classical setting [26]. The key idea is to randomize inputs to classifiers by perturbing them with additive Gaussian noise. This results in smoother decision boundaries which in turn leads to improved robustness to adversarial attacks. In this section, we extend this concept to the quantum setting by interpreting quantum noise channels as “smoothing” channels. The idea of harnessing actively induced input noise in quantum classifiers to increase robustness has recently been proposed in Ref. [17] where robustness bound with techniques from differential privacy has been derived. In the following, we take a similar path and consider a depolarization noise channel and analytically derive a larger robustness radius for pure single-qubit input states.

2. Quantum channel smoothing: depolarization

Consider depolarization noise which maps a state σ onto a linear combination of itself and the maximally mixed state

$$\sigma \mapsto \mathcal{E}_p^{\text{dep}}(\sigma) := (1-p)\sigma + \frac{p}{d} \mathbb{1}_d \quad (28)$$

where $p \in (0, 1)$ is the depolarization parameter and d is the dimensionality of the underlying Hilbert space. In single-qubit scenarios, this can geometrically be interpreted as a uni-

form contraction of the Bloch sphere parametrized by p , pushing quantum states towards the completely mixed state. Analogously to classical randomized smoothing, we apply a depolarization channel to inputs before passing them through the classifier in order to artificially randomize the states and increase robustness against adversarial attacks. We then obtain a robustness guarantee by instantiating Theorem 1 in the following way. Let σ be a benign input state and suppose that the classifier \mathbf{y} outputs class probabilities which satisfy

$$\mathbf{y}_{k_A}(\mathcal{E}_p^{\text{dep}}(\sigma)) \geq p_A > p_B \geq \max_{k \neq k_A} \mathbf{y}_k(\mathcal{E}_p^{\text{dep}}(\sigma)). \quad (29)$$

Then \mathbf{y} is robust at $\mathcal{E}_p^{\text{dep}}(\rho)$ for any adversarial input state ρ which satisfies the robustness condition (8), where M_A^* and M_B^* are Helstrom operators for testing $\mathcal{E}_p^{\text{dep}}(\sigma)$ against $\mathcal{E}_p^{\text{dep}}(\rho)$ and which have false alarm probabilities $1 - p_A$ and p_B respectively. In particular, if σ and ρ are single-qubit pure states and in the case where we have $p_A + p_B = 1$, the robustness condition can be equivalently expressed in terms of the trace distance as $T(\rho, \sigma) < R_p^{\text{QHT}}$ with

$$R_p^{\text{QHT}} = \begin{cases} \sqrt{\frac{1}{2} - \frac{\sqrt{g_p(p_A)}}{1-p}}, & p_A < \frac{1+3(1-p)^2}{2+2(1-p)^2} \\ \sqrt{\frac{p \cdot (2-p) \cdot (1-2p_A)^2}{8(1-p)^2 \cdot (1-p_A)}}, & p_A \geq \frac{1+3 \cdot (1-p)^2}{2+2 \cdot (1-p)^2} \end{cases} \quad (30)$$

where

$$g_p(p_A) = \frac{1}{2} \left(2p_A(1-p_A) - p \left(1 - \frac{p}{2} \right) \right). \quad (31)$$

A detailed derivation of this bound is given in Corollary 3 in the supplementary materials.

The Hölder bound from Lemma 1 can also be adapted to the noisy setting. Specifically, since for two states σ and ρ , the trace distance obeys $T(\mathcal{E}_p^{\text{dep}}(\rho), \mathcal{E}_p^{\text{dep}}(\sigma)) = (1-p) \cdot T(\rho, \sigma)$, Lemma 1 implies robustness given that the trace distance is less than $T(\rho, \sigma) < R_p^{\text{Hölder}}$ where

$$R_p^{\text{Hölder}} = \frac{2p_A - 1}{2(1-p)}. \quad (32)$$

In [17] it has been shown that naturally occurring noise in a quantum circuit can be harnessed to increase the robustness of quantum classification algorithms. Specifically, using techniques from quantum differential privacy, a robustness bound expressible in terms of the class probabilities p_A and the depolarization parameter p has been derived. Written in our notation and for single-qubit binary classification, the bound can be written as

$$R_p^{\text{DP}} = \frac{p}{2(1-p)} \left(\sqrt{\frac{p_A}{1-p_A}} - 1 \right) \quad (33)$$

and robustness is guaranteed for any adversarial state ρ with $T(\rho, \sigma) < R_p^{\text{DP}}$. In FIG 4 the three bounds are compared graphically for different values of the noise parameter p , showing that the QHT bound gives rise to a tighter robustness condition for all values of p .

Additionally, we note that in the presence of depolarization noise, the robust regions can cover the entire Bloch sphere if

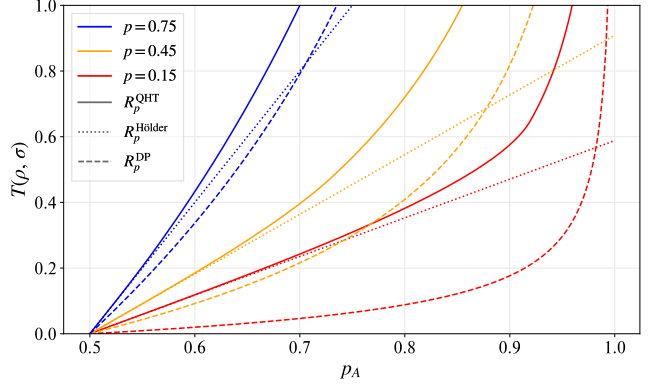

FIG. 4: Comparison of Robustness bounds for single-qubit pure states derived from quantum hypothesis testing R_p^{QHT} , Hölder duality $R_p^{\text{Hölder}}$ and quantum differential privacy R_p^{DP} [17] with different levels of depolarization noise p .

p_A is large enough and the robust radius (in terms of trace distance) becomes 1. In particular, from FIG. 4 we can see that as the depolarization parameter p increases, the prediction confidence p_A at which the robust radius is 1, decreases. This indicates that as the input approaches the maximally mixed state, it becomes harder for classifiers to distinguish between states. The fact that the robust radius can cover the entire Bloch sphere, implies that if a quantum classifier becomes “too confident” in classifying a given input state, it will be constant, hinting at a fundamental limitation on the ability of quantum classifiers to distinguish between different classes of states.

It is worth remarking that although the QHT robustness bound can be, as shown here for the case of applying depolarization channel, enhanced by input randomization, it already presents a valid, non-trivial condition with deterministic (without smoothing) quantum input (Theorem 1). This contrasts with the classical scenario, where the addition of classical noise sources to the input state is necessary to generate a probability distribution corresponding to the input data, from which an adversarial robustness bound can be derived [26]. This distinction between the quantum and classical settings roots in the probabilistic nature of measurements on quantum states, which of course applies to both pure and mixed state inputs.

IV. CONCLUSION AND OUTLOOK

We have seen how a fundamental connection between adversarial robustness of quantum classifiers and quantum hypothesis testing (QHT) can be leveraged to provide a powerful framework for deriving optimal conditions for robustness certification. This also gives rise to a practical robustness certification protocol. This robustness condition is provably tight when expressed in terms of error rates of QHT for binary classifications, or more generally for all classifications in which the probability of the most likely class is greater than

1/2. When expressed explicitly in terms of trace distances, the QHT robustness bound is proved to be tight when the input states are pure. Furthermore, we have shown how using a randomized input with depolarization channel enhances the QHT bound, consistent with previous results, in a manner akin to randomized smoothing in robustness certification of classical machine learning.

A key difference between the quantum and classical formalism is that quantum states themselves have a naturally probabilistic interpretation, even though the classical data that could be embedded in quantum states do not need to be probabilistic. This difference is an important source of potential quantum advantage in adversarial robustness. We now know that both classical and quantum optimal robustness bounds for classification protocols depend on bounds provided by hypothesis testing. However, hypothesis testing involves the comparison of probability distributions, which can only be possible in the classical case with the addition of stochastic noise sources if the classical data is initially non-stochastic. This means that the optimal robustness bounds in the classical case only exist for noisy classifiers which also require training under the additional noise [26]. This is in contrast to the quantum scenario. Our quantum adversarial robustness bound can be proved independently of randomized input, even though it can be enhanced by it, like through a depolarization channel. Thus in the quantum regime, unlike in the classical scenario, we are

not forced to consider training under actively induced noise.

Our optimal provable robustness bound and the connection to quantum hypothesis testing also provides a first step towards more rigorously identifying the limitations of quantum classifiers in its power of distinguishing between input quantum states. Our formalism hints at an intimate relationship between these fundamental limitations in the accuracy of distinguishing between different classes of states and robustness. This could shed light on the robustness and accuracy trade-offs observed in classification protocols [38] and is an important direction of future research. It is also of independent interest to explore possible connections between tasks that use quantum hypothesis testing, such as quantum illumination [32] and state discrimination [39], with accuracy and robustness in quantum classification.

ACKNOWLEDGEMENTS

The authors are grateful to Ryan LaRose (Michigan State University), Zi-Wen Liu (Perimeter Institute for Theoretical Physics), Barry Sanders (University of Calgary) and Robert Pisarczyk (University of Oxford) for inspiring discussions on the question of robustness in quantum machine learning.

-
- [1] Vedran Dunjko and Hans J Briegel. Machine learning & artificial intelligence in the quantum domain. *arXiv:1709.02779*, 2017.
 - [2] Jacob Biamonte, Peter Wittek, Nicola Pancotti, Patrick Rebentrost, Nathan Wiebe, and Seth Lloyd. Quantum machine learning. *Nature*, 549(7671):195–202, 2017.
 - [3] Maria Schuld, Ilya Sinayskiy, and Francesco Petruccione. An introduction to quantum machine learning. *Contemporary Physics*, 56(2):172–185, 2015.
 - [4] Zhikuan Zhao, Alejandro Pozas-Kerstjens, Patrick Rebentrost, and Peter Wittek. Bayesian deep learning on a quantum computer. *Quantum Machine Intelligence*, 1(1-2):41–51, 2019.
 - [5] Iris Cong, Soonwon Choi, and Mikhail D Lukin. Quantum convolutional neural networks. *Nature Physics*, 15(12):1273–1278, 2019.
 - [6] Patrick Rebentrost, Masoud Mohseni, and Seth Lloyd. Quantum support vector machine for big data classification. *Physical review letters*, 113(13):130503, 2014.
 - [7] Edward Farhi and Hartmut Neven. Classification with quantum neural networks on near term processors. *arXiv:1802.06002*, 2018.
 - [8] Vojtěch Havlíček, Antonio D. Córcoles, Kristan Temme, Aram W. Harrow, Abhinav Kandala, Jerry M. Chow, and Jay M. Gambetta. Supervised learning with quantum-enhanced feature spaces. *Nature*, 567(7747):209–212, 2019.
 - [9] Maria Schuld and Nathan Killoran. Quantum machine learning in feature hilbert spaces. *Physical review letters*, 122(4):040504, 2019.
 - [10] Seth Lloyd, Maria Schuld, Aroosa Ijaz, Josh Izaac, and Nathan Killoran. Quantum embeddings for machine learning. *arXiv:2001.03622*, 2020.
 - [11] Sirui Lu, Lu-Ming Duan, and Dong-Ling Deng. Quantum adversarial machine learning. *Phys. Rev. Research*, 2:033212, Aug 2020.
 - [12] Nana Liu and Peter Wittek. Vulnerability of quantum classification to adversarial perturbations. *Phys. Rev. A*, 101:062331, Jun 2020.
 - [13] Christian Szegedy, Wojciech Zaremba, Ilya Sutskever, Joan Bruna, Dumitru Erhan, Ian Goodfellow, and Rob Fergus. Intriguing properties of neural networks. In *International Conference on Learning Representations*, 2014.
 - [14] Ian Goodfellow, Jonathon Shlens, and Christian Szegedy. Explaining and harnessing adversarial examples. In *International Conference on Learning Representations*, 2015.
 - [15] John Preskill. Quantum computing in the nisq era and beyond. *Quantum*, 2:79, 2018.
 - [16] Nathan Wiebe and Ram Shankar Siva Kumar. Hardening quantum machine learning against adversaries. *New Journal of Physics*, 20(12):123019, dec 2018.
 - [17] Yuxuan Du, Min-Hsiu Hsieh, Tongliang Liu, Dacheng Tao, and Nana Liu. Quantum noise protects quantum classifiers against adversaries. *arXiv:2003.09416*, 2020.
 - [18] Ji Guan, Wang Fang, and Mingsheng Ying. Robustness verification of quantum machine learning. *arXiv:2008.07230*, 2020.
 - [19] Ryan LaRose and Brian Coyle. Robust data encodings for quantum classifiers. *arXiv:2003.01695*, 2020.
 - [20] K. Eykholt, I. Evtimov, E. Fernandes, B. Li, A. Rahmati, C. Xiao, A. Prakash, T. Kohno, and D. Song. Robust physical-world attacks on deep learning visual classification. In *2018 IEEE/CVF Conference on Computer Vision and Pattern Recognition*, pages 1625–1634, 2018.
 - [21] Nicholas Carlini and David Wagner. Adversarial examples are

- not easily detected: Bypassing ten detection methods. In *Proceedings of the 10th ACM Workshop on Artificial Intelligence and Security*, pages 3–14, 2017.
- [22] Anish Athalye, Nicholas Carlini, and David Wagner. Obfuscated gradients give a false sense of security: Circumventing defenses to adversarial examples. In *Proceedings of the 35th International Conference on Machine Learning*, pages 274–283, 2018.
- [23] Sven Gowal, Krishnamurthy Dvijotham, Robert Stanforth, Rudy Bunel, Chongli Qin, Jonathan Uesato, Relja Arandjelovic, Timothy Mann, and Pushmeet Kohli. On the effectiveness of interval bound propagation for training verifiably robust models. *arXiv:1810.12715*, 2018.
- [24] Matthew Mirman, Timon Gehr, and Martin Vechev. Differentiable abstract interpretation for provably robust neural networks. In *International Conference on Machine Learning*, pages 3578–3586, 2018.
- [25] Mathias Léculuyer, Vaggelis Atlidakis, Roxana Geambasu, Daniel Hsu, and Suman Jana. Certified robustness to adversarial examples with differential privacy. In *IEEE Symposium on Security and Privacy*, pages 656–672. IEEE, 2019.
- [26] Jeremy Cohen, Elan Rosenfeld, and Zico Kolter. Certified adversarial robustness via randomized smoothing. In *International Conference on Machine Learning*, pages 1310–1320, 2019.
- [27] Carl W. Helstrom. Detection theory and quantum mechanics. *Information and Control*, 10(3):254–291, 1967.
- [28] A.S Holevo. Statistical decision theory for quantum systems. *Journal of Multivariate Analysis*, 3(4):337–394, 1973.
- [29] Ligong Wang and Renato Renner. One-shot classical-quantum capacity and hypothesis testing. *Phys. Rev. Lett.*, 108:200501, May 2012.
- [30] W. Matthews and S. Wehner. Finite blocklength converse bounds for quantum channels. *IEEE Transactions on Information Theory*, 60(11):7317–7329, 2014.
- [31] Carl W. Helstrom. *Quantum Detection and Estimation Theory*, volume 123 of *Mathematics in Science and Engineering*. Academic Press, New York, 1976.
- [32] Mark M. Wilde, Marco Tomamichel, Seth Lloyd, and Mario Berta. Gaussian hypothesis testing and quantum illumination. *Phys. Rev. Lett.*, 119:120501, Sep 2017.
- [33] Seth Lloyd. Enhanced sensitivity of photodetection via quantum illumination. *Science*, 321(5895):1463–1465, 2008.
- [34] R. Gordon Wasson. The death of claudius or mushrooms for murderers. *Botanical Museum Leaflets, Harvard University*, 23(3):101–128, 1972.
- [35] J. Neyman and E. S. Pearson. On the problem of the most efficient tests of statistical hypotheses. *Phil. Trans. Roy. Statistical Soc. A*, 231:289–337, 1933.
- [36] Zhikuan Zhao, Jack K Fitzsimons, Patrick Reberntrost, Vedran Dunjko, and Joseph F Fitzsimons. Smooth input preparation for quantum and quantum-inspired machine learning. *arXiv:1804.00281*, 2018.
- [37] Marcello Benedetti, Erika Lloyd, Stefan Sack, and Mattia Fiorentini. Parameterized quantum circuits as machine learning models. *Quantum Science and Technology*, 4(4):043001, 2019.
- [38] Dimitris Tsipras, Shibani Santurkar, Logan Engstrom, Alexander Turner, and Aleksander Madry. Robustness may be at odds with accuracy. In *International Conference on Learning Representations*, 2019.
- [39] Gael Sentís, Alex Monràs, Ramon Muñoz Tapia, John Calsamiglia, and Emilio Bagan. Unsupervised classification of quantum data. *Phys. Rev. X*, 9:041029, Nov 2019.
- [40] Rajendra Bhatia. *Matrix Analysis*, volume 169. Springer, 1997.
- [41] Robert D. Richtmeyer. *Principles of Advanced Mathematical Physics*, volume 1. Springer, 1978.

Appendix A: Supplementary Materials

Here we provide all proofs for the theoretical results presented in the main part. We first show a collection of technical lemmas related to quantum hypothesis testing with the goal of explicitly constructing Helstrom operators which attain a preassigned level of type-I error probability. Given this construction, we then proceed to prove Theorem 1 and derive the robustness bounds in terms of trace distance for pure-pure and pure-mixed benign and adversarial quantum states presented in Corollaries 1 and 2. Finally, we formally derive the robustness bound for noisy input scenarios discussed in Section III B.

1. Preliminaries

The proofs for our results are largely expressed in the language of quantum hypothesis testing. For that purpose, we first recall the central quantities of interest. As in the main part of this paper, the null hypothesis corresponds to a benign input state and is described by a density operator $\sigma \in \mathcal{S}(\mathcal{H})$ acting on a Hilbert space \mathcal{H} of finite dimension $d := \dim(\mathcal{H}) < \infty$. The density operator for the alternative hypothesis is denoted by ρ and corresponds the adversarial state in the classification setting. A quantum hypothesis test is defined by a positive semi-definite operator $0 \leq M \leq \mathbb{1}_d$ and the type-I and type-II error probabilities associated with M are denoted by α and β and are defined by

$$\alpha(M) := \text{Tr}[\sigma M], \quad \beta(M) := \text{Tr}[\rho(\mathbb{1} - M)]. \quad (\text{A1})$$

For two Hermitian operators A and B , we write $A \geq B$ ($A \leq B$) if $A - B$ is positive (negative) semi-definite and $A > B$ ($A < B$) if $A - B$ is positive (negative) definite. For a Hermitian operator A with spectral decomposition $A = \sum_i \lambda_i P_i$ with eigenvalues $\{\lambda_i\}_i$ and orthogonal projections onto the associated eigenspaces $\{P_i\}_i$, we write

$$\{A > 0\} := \sum_{i: \lambda_i > 0} P_i, \quad \{A < 0\} := \sum_{i: \lambda_i < 0} P_i \quad (\text{A2})$$

for the projections onto the eigenspaces associated with positive and negative eigenvalues respectively. Finally, for $t \geq 0$ define the operators

$$P_{t,+} := \{\rho - t\sigma > 0\}, \quad P_{t,-} := \{\rho - t\sigma < 0\}, \quad P_{t,0} := \mathbb{1} - P_{t,+} - P_{t,-}. \quad (\text{A3})$$

The Helstrom operators are then defined as

$$M_t := P_{t,+} + X_t, \quad 0 \leq X_t \leq P_{t,0}. \quad (\text{A4})$$

2. Technical Lemmas

The following Lemmas justify the existence and give an explicit construction of Helstrom operators attaining a preassigned level of type-I error probability α_0 . We first show that if a sequence of bounded Hermitian operators A_n converges in operator norm to a bounded Hermitian operator A from above (below), then the projection $\{A_n < 0\}$ ($\{A_n > 0\}$) converges to $\{A < 0\}$ ($\{A > 0\}$) in operator norm. This subsequently allows us to show that the function $t \mapsto \alpha(P_{t,+})$ is non-increasing and continuous from the right, and that $t \mapsto \alpha(P_{t,+} + P_{t,0})$ is non-increasing and continuous from the left. As a consequence, for $\alpha_0 \in (0, 1)$, the quantity

$$\tau(\alpha_0) := \inf\{t \geq 0: \alpha(P_{t,+}) \leq \alpha_0\} \quad (\text{A5})$$

is well defined. This implies the chain of inequalities

$$\alpha(P_{\tau(\alpha_0),+}) \leq \alpha_0 \leq \alpha(P_{\tau(\alpha_0),+} + P_{\tau(\alpha_0),0}). \quad (\text{A6})$$

Based on this, we construct a Helstrom operator $M_{\tau(\alpha_0)}$ according to

$$M_{\tau(\alpha_0)} := P_{\tau(\alpha_0),+} + q_0 P_{\tau(\alpha_0),0}, \quad q_0 := \begin{cases} \frac{\alpha_0 - \alpha(P_{\tau(\alpha_0),+})}{\alpha(P_{\tau(\alpha_0),0})} & \text{if } \alpha(P_{\tau(\alpha_0),0}) \neq 0, \\ 0 & \text{otherwise.} \end{cases} \quad (\text{A7})$$

which attains the preassigned type-I error probability α_0 .

Lemma 2. Denote by $\mathcal{B}(\mathcal{H})$ the space of bounded linear operators acting on the finite dimensional Hilbert space \mathcal{H} , $d := \dim(\mathcal{H}) < \infty$. Let $A \in \mathcal{B}(\mathcal{H})$ and $\{A_n\}_{n \in \mathbb{N}} \subset \mathcal{B}(\mathcal{H})$ be Hermitian operators and suppose that $\|A_n - A\|_{op} \xrightarrow{n \rightarrow \infty} 0$. Then, it holds that

$$(i) \quad A - A_n \leq 0 \Rightarrow \|\{A_n < 0\} - \{A < 0\}\|_{op} \xrightarrow{n \rightarrow \infty} 0, \quad (\text{A8})$$

$$(ii) \quad A - A_n \geq 0 \Rightarrow \|\{A_n > 0\} - \{A > 0\}\|_{op} \xrightarrow{n \rightarrow \infty} 0. \quad (\text{A9})$$

Proof. We first show that convergence in operator norm implies that the eigenvalues of A_n converge towards the eigenvalues A . For a linear operator M let $\lambda_k(M)$ denote its k -th largest eigenvalue, $\lambda_1(M) \geq \dots \geq \lambda_d(M)$, where $q \leq d$ is the number of distinct eigenvalues of M . By the minimax principle (e.g. [40], chapter 3), we can compute λ_k for any Hermitian operator M according to

$$\lambda_k(M) = \max_{\substack{V \subset \mathcal{H} \\ \dim(V)=k}} \min_{\substack{\psi \in V \\ \|\psi\|=1}} \langle \psi | M | \psi \rangle. \quad (\text{A10})$$

Now let $\varepsilon > 0$ and let $n \in \mathbb{N}$ large enough such that $\|A_n - A\|_{op} < \varepsilon$. Let $|\psi\rangle \in \mathcal{H}$ be a normalized state and note that by the Cauchy-Schwartz inequality we have

$$|\langle \psi | (A_n - A) | \psi \rangle| \leq \|(A_n - A)\psi\| \|\psi\| \leq \|A_n - A\|_{op} \|\psi\|^2 < \varepsilon \quad (\text{A11})$$

and thus

$$\langle \psi | A | \psi \rangle - \varepsilon < \langle \psi | A_n | \psi \rangle < \langle \psi | A | \psi \rangle + \varepsilon. \quad (\text{A12})$$

Hence, for any fixed $k \geq 1$ and any subspace $V \subset \mathcal{H}$ with $\dim(V) = k$, we have

$$\min_{\substack{\psi \in V \\ \|\psi\|=1}} \langle \psi | A | \psi \rangle - \varepsilon < \min_{\substack{\psi \in V \\ \|\psi\|=1}} \langle \psi | A_n | \psi \rangle < \min_{\substack{\psi \in V \\ \|\psi\|=1}} \langle \psi | A | \psi \rangle + \varepsilon \quad (\text{A13})$$

and thus, from (A10), we see that

$$\lambda_k(A) - \varepsilon < \lambda_k(A_n) < \lambda_k(A) + \varepsilon \Rightarrow |\lambda_k(A) - \lambda_k(A_n)| < \varepsilon \quad (\text{A14})$$

and hence

$$\lambda_k(A_n) \xrightarrow{n \rightarrow \infty} \lambda_k(A), \quad k = 1, \dots, q. \quad (\text{A15})$$

Alternatively, this can be seen from Weyl's Perturbation Theorem (e.g. [40], ch. 3): namely, since A and A_n are Hermitian, it follows immediately from $|\lambda_k(A) - \lambda_k(A_n)| \leq \max_k |\lambda_k(A) - \lambda_k(A_n)| \leq \|A - A_n\|_{op}$ that eigenvalues converge provided that $\|A_n - A\|_{op} \rightarrow 0$. We will now make use of function theory and the resolvent formalism to show the convergence of the positive and negative eigenprojections. Let $M \in \mathcal{B}(\mathcal{H})$ be Hermitian, let $\sigma(M)$ denote the spectrum of M and, for $\lambda \in \mathbb{C} \setminus \sigma(M)$, let

$$R_\lambda(M) := (M - \lambda \mathbb{1})^{-1} = - \sum_{k=0}^{\infty} \lambda^{-(k+1)} M^k \quad (\text{A16})$$

be the resolvent of the operator M . The sum is the Neumann series and converges for $\lambda \in \mathbb{C} \setminus \sigma(M)$. Since M is Hermitian, we can write its spectral decomposition in terms of contour integrals over the resolvent

$$M = \sum_{k=1}^q \lambda_k(M) P_k \quad \text{with} \quad P_k = \frac{1}{2\pi i} \oint_{(\gamma_k, -)} R_\lambda(M) d\lambda, \quad \text{and} \quad \sum_{k=1}^q P_k = \mathbb{1} \quad (\text{A17})$$

where P_k is the orthogonal projection onto the k -th eigenspace and the integration is to be understood element-wise. The symbol $(\gamma_k, -)$ indicates that the contour encircles $\lambda_k(M)$ once negatively, but does not encircle any other eigenvalue of M . We refer the reader to [41] for a detailed derivation.

We now show part (i) of the Lemma. For ease of notation, let λ_k denote the k -th eigenvalue of A and $\lambda_{k,n}$ the k -th eigenvalue of A_n . Since A_n and A are Hermitian operators, we can write the eigenprojections $\{A_n < 0\}$ and $\{A < 0\}$ in terms of the resolvent as

$$\{A < 0\} = \frac{1}{2\pi i} \sum_{k: \lambda_k < 0} \oint_{(\gamma_k, -)} R_\lambda(A) d\lambda, \quad \{A_n < 0\} = \frac{1}{2\pi i} \sum_{k: \lambda_{k,n} < 0} \oint_{(\gamma_{k,n}, -)} R_\lambda(A_n) d\lambda \quad (\text{A18})$$

where the symbols $(\gamma_k, -)$ and $(\gamma_{k,n}, -)$ indicate that the contours encircle only λ_k and $\lambda_{k,n}$ once negatively and no other eigenvalues of A and A_n respectively. Since by assumption $A_n \geq A$ and A_n, A are Hermitian, it follows from Weyl's Monotonicity Theorem that $\lambda_{k,n} \geq \lambda_k$. Let λ_K be the largest negative eigenvalue of A , that is $\lambda_1 \geq \lambda_2 \geq \dots \geq \lambda_{K-1} \geq 0 > \lambda_K \geq \dots \geq \lambda_q$. Note that if A is positive semidefinite, then so is A_n and the statement follows trivially from $\{A_n < 0\} = \{A < 0\} = \emptyset$. Thus, without loss of generality, we can assume that at least one eigenvalue of A is negative. Since $\lambda_{k,n} \geq \lambda_k$, and in particular $\lambda_{K-1,n} \geq \lambda_{K-1} \geq 0$, there exists $N_0 \in \mathbb{N}$ large enough such that $\lambda_{K-1,n} \geq 0 > \lambda_{K,n}$ for all $n \geq N_0$. Let r_0 be the smallest distance between two eigenvalues of A

$$r_0 := \min_k |\lambda_k - \lambda_{k+1}| \quad (\text{A19})$$

and let $0 < \varepsilon < \frac{r_0}{2}$. Choose $N_1 \geq N_0$ large enough such that $\max_{k \geq K} |\lambda_{k,n} - \lambda_k| < \varepsilon/2$. Let $0 < \delta < \frac{r_0}{2} - \varepsilon$ and for $k \geq K$ let $B_{\delta+\varepsilon}^k := B_{\delta+\varepsilon}(\lambda_k)$ be the open ball of radius $\delta + \varepsilon$ centered at λ_k . Note that $\partial B_{\delta+\varepsilon}^k$ encircles both $\lambda_{k,n}$ and λ_k . Then, for $k \geq K$ and $n \geq N_1$, the mappings

$$\lambda \mapsto R_\lambda(A), \quad \lambda \in B_{\delta+\varepsilon}^k \setminus \{\lambda_k\}, \quad (\text{A20})$$

$$\lambda \mapsto R_\lambda(A_n), \quad \lambda \in B_{\delta+\varepsilon}^k \setminus \{\lambda_{k,n}\} \quad (\text{A21})$$

are holomorphic functions of λ and each has an isolated (simple) singularity at λ_k and $\lambda_{k,n}$ respectively. Let $\gamma_{k,n}$ be a contour around $\lambda_{k,n}$ encircling no other eigenvalue of A_n . Note that the contours $\gamma_{k,n}$ and $\partial B_{\delta+\varepsilon}^k$ are homotopic (in $B_{\delta+\varepsilon}^k \setminus \{\lambda_{k,n}\}$). Thus, for all $k \geq K$ and $n \geq N_1$, Cauchy's integral Theorem yields

$$\oint_{\gamma_{k,n}} R_\lambda(A_n) d\lambda = \oint_{\partial B_{\delta+\varepsilon}^k} R_\lambda(A_n) d\lambda. \quad (\text{A22})$$

With this, we see that for $n \geq N_1$

$$\{A_n < 0\} - \{A < 0\} = \frac{1}{2\pi i} \sum_{k=K}^q \left(\oint_{\partial B_{\delta+\varepsilon}^k} R_\lambda(A) d\lambda - \oint_{\gamma_{k,n}} R_\lambda(A_n) d\lambda \right) \quad (\text{A23})$$

$$= \frac{1}{2\pi i} \sum_{k=K}^q \left(\oint_{\partial B_{\delta+\varepsilon}^k} (R_\lambda(A) - R_\lambda(A_n)) d\lambda \right) \quad (\text{A24})$$

and thus, by the triangle inequality

$$\|\{A_n < 0\} - \{A < 0\}\|_{op} \leq \frac{1}{2\pi} \sum_{k=K}^q \left\| \oint_{\partial B_{\delta+\varepsilon}^k} (R_\lambda(A) - R_\lambda(A_n)) d\lambda \right\|_{op} \quad (\text{A25})$$

$$\leq \frac{1}{2\pi} \sum_{k=K}^q \sup_{\lambda \in \partial B_{\delta+\varepsilon}^k} \|R_\lambda(A) - R_\lambda(A_n)\|_{op} \cdot 2\pi \cdot (\delta + \varepsilon) \quad (\text{A26})$$

$$\leq (q - (K - 1)) \cdot (\delta + \varepsilon) \cdot \max_{k \geq K} \left(\sup_{\lambda \in \partial B_{\delta+\varepsilon}^k} \|R_\lambda(A) - R_\lambda(A_n)\|_{op} \right). \quad (\text{A27})$$

Furthermore, for any k and $\lambda \in \partial B_{\delta+\varepsilon}^k$, the second resolvent identity yields

$$\begin{aligned} \|R_\lambda(A) - R_\lambda(A_n)\|_{op} &= \|R_\lambda(A)(A - A_n)R_\lambda(A)\|_{op} \\ &\leq \|A - A_n\|_{op} \cdot \|R_\lambda(A)\|_{op} \|R_\lambda(A_n)\|_{op}. \end{aligned} \quad (\text{A28})$$

We now show that the supremum over $\lambda \in \partial B_{\delta+\varepsilon}^k$ in the right hand side of (A28) is bounded. Since both A and A_n are Hermitian, it follows that their resolvent is normal and bounded for $\lambda \in \mathbb{C} \setminus \sigma(A_n)$ and $\lambda \in \mathbb{C} \setminus \sigma(A)$ respectively. The operator norm is thus given by the spectral radius,

$$\|R_\lambda(A)\|_{op} = \max_k |\lambda_k(R_\lambda(A))| \quad \text{and} \quad \|R_\lambda(A_n)\|_{op} = \max_k |\lambda_k(R_\lambda(A_n))|. \quad (\text{A29})$$

Note that the eigenvalues of $R_\lambda(A)$ are given by $(\lambda_k(A) - \lambda)^{-1}$. To see this, let $\lambda \in \mathbb{C} \setminus \sigma(A)$ and consider

$$\det(R_\lambda(A) - \mu \mathbb{1}) = \det((A - \lambda \mathbb{1})^{-1} (\mathbb{1} - (A - \lambda \mathbb{1})\mu \mathbb{1})) \quad (\text{A30})$$

$$\propto \det(\mathbb{1} - (A - \lambda \mathbb{1})\mu \mathbb{1}) = (-\mu)^m \det(A - (\mu^{-1} + \lambda) \mathbb{1}). \quad (\text{A31})$$

Since $\det(R_\lambda(A)) \neq 0$ it follows that $\mu = 0$ can not be an eigenvalue. Thus, eigenvalues of $R_\lambda(A)$ satisfy

$$\frac{1}{\mu} + \lambda = \lambda_k(A) \Rightarrow \mu = \frac{1}{\lambda_k(A) - \lambda}. \quad (\text{A32})$$

The same reasoning yields an expression for eigenvalues of $R_\lambda(A_n)$. Thus

$$\|R_\lambda(A)\|_{op} = \max_k \frac{1}{|\lambda_k(A) - \lambda|} \quad \text{and} \quad \|R_\lambda(A_n)\|_{op} = \max_k \frac{1}{|\lambda_k(A_n) - \lambda|}. \quad (\text{A33})$$

Note that, by the definition of δ , for $\lambda \in \partial B_{\delta+\varepsilon}^k$, the eigenvalue of A which is nearest to λ is given by $\lambda_k(A)$. Since this is exactly the center of the ball $B_{\delta+\varepsilon}$, it follows that

$$\sup_{\lambda \in \partial B_{\delta+\varepsilon}^k} \|R_\lambda(A)\|_{op} = \frac{1}{\delta + \varepsilon} < \infty. \quad (\text{A34})$$

Similarly, for $\lambda \in \partial B_{\delta+\varepsilon}^k$, the eigenvalue of A_n which is nearest to λ is given $\lambda_k(A_n)$ since n was chosen large enough such that $|\lambda_k(A_n) - \lambda_k(A)| < \varepsilon$ and $\varepsilon < r_0/2$. Since $\delta < \frac{r_0}{2} - \varepsilon$, it follows that the smallest distance from $\partial B_{\delta+\varepsilon}^k$ to $\lambda_k(A_n)$ is exactly δ and thus

$$\sup_{\lambda \in \partial B_{\delta+\varepsilon}^k} \|R_\lambda(A_n)\|_{op} = \frac{1}{\delta} < \infty. \quad (\text{A35})$$

Hence, we find that the RHS in (A28) is bounded by $\frac{\|A_n - A\|_{op}}{(\delta + \varepsilon)\delta}$ for $\lambda \in \partial B_{\delta + \varepsilon}^k$. Finally, this yields

$$\|\{A_n < 0\} - \{A < 0\}\|_{op} \leq (\delta + \varepsilon)(q - (K - 1)) \max_{k \geq K} \left(\sup_{\lambda \in \partial B_{\delta + \varepsilon}^k} \|R_\lambda(A) - R_\lambda(A_n)\|_{op} \right) \quad (\text{A36})$$

$$\leq (\delta + \varepsilon)(q - (K - 1)) \|A_n - A\|_{op} \frac{1}{\delta + \varepsilon} \frac{1}{\delta} \quad (\text{A37})$$

$$= \frac{q - (K - 1)}{\delta} \|A_n - A\|_{op} \xrightarrow{n \rightarrow \infty} 0. \quad (\text{A38})$$

In an analogous way we can show that

$$\|\{A_n > 0\} - \{A > 0\}\|_{op} \leq \frac{R}{\delta} \|A_n - A\|_{op} \xrightarrow{n \rightarrow \infty} 0 \quad (\text{A39})$$

where R denotes the index of the smallest positive eigenvalue of A . This concludes the proof. \square

Lemma 3. *The functions $t \mapsto \alpha(P_{t,+})$ and $t \mapsto \alpha(P_{t,+} + P_{t,0})$ are non-increasing.*

Proof. Let $0 \leq s < t$. We need to show that $\text{Tr}[\sigma P_{s,+}] \geq \text{Tr}[\sigma P_{t,+}]$ and $\text{Tr}[\sigma(P_{s,+} + P_{s,0})] \geq \text{Tr}[\sigma(P_{t,+} + P_{t,0})]$. Note that for any Hermitian operator A on and for any Hermitian operator $0 \leq T \leq \mathbb{1}$ we have

$$\text{Tr}[A\{A \geq 0\}] = \text{Tr}[A\{A > 0\}] \geq \text{Tr}[A \cdot T] \quad (\text{A40})$$

We first show $\text{Tr}[\sigma P_{s,+}] \geq \text{Tr}[\sigma P_{t,+}]$. Write $T_s := \rho - s\sigma$ and $T_t := \rho - t\sigma$ and note that the eigenprojections are Hermitian and satisfy

$$0 \leq \{T_s > 0\} \leq \mathbb{1}, \quad \text{and} \quad 0 \leq \{T_t > 0\} \leq \mathbb{1} \quad (\text{A41})$$

It follows that

$$\text{Tr}[T_t\{T_t > 0\}] \geq \text{Tr}[T_t\{T_s > 0\}] \quad (\text{A42})$$

and similarly

$$\text{Tr}[T_s\{T_s > 0\}] \geq \text{Tr}[T_s\{T_t > 0\}]. \quad (\text{A43})$$

Combining (A42) and (A43) yields

$$t \cdot (\text{Tr}[\sigma\{T_s > 0\}] - \text{Tr}[\sigma\{T_t > 0\}]) \geq s \cdot (\text{Tr}[\sigma\{T_s > 0\}] - \text{Tr}[\sigma\{T_t > 0\}]). \quad (\text{A44})$$

Since $s < t$ it follows that $\text{Tr}[\sigma\{T_s > 0\}] \geq \text{Tr}[\sigma\{T_t > 0\}]$ and thus $\alpha(P_{s,+}) \geq \alpha(P_{t,+})$. The other statement follows analogously by replacing $\{T_t > 0\}$ and $\{T_s > 0\}$ by $\{T_t \geq 0\}$ and $\{T_s \geq 0\}$. This concludes the proof. \square

Lemma 4. *The function $t \mapsto \alpha(P_{t,+})$ is continuous from the right.*

Proof. Let $t \geq 0$ and let $\{t_n\}_{n \in \mathbb{N}} \subseteq [0, \infty)$ be a sequence such that $t_n \downarrow t$ (i.e. t_n converges to t from above). We show that $\lim_{n \rightarrow \infty} \alpha(P_{t_n,+}) = \alpha(P_{t,+})$. Define the operators

$$A_n := \rho - t_n\sigma, \quad A := \rho - t\sigma \quad (\text{A45})$$

and note that

$$\|A_n - A\|_{op} = |t_n - t| \cdot \|\sigma\|_{op} \xrightarrow{n \rightarrow \infty} 0. \quad (\text{A46})$$

Since, in addition, both A_n and A are Hermitian and $A - A_n = (t_n - t)\sigma \geq 0$, it follows from the second part of Lemma 2 that

$$\|\{A_n > 0\} - \{A > 0\}\|_{op} \xrightarrow{n \rightarrow \infty} 0 \quad (\text{A47})$$

and thus

$$\alpha(P_{t_n,+}) = \text{Tr}[\sigma\{A_n > 0\}] \xrightarrow{n \rightarrow \infty} \text{Tr}[\sigma\{A > 0\}] = \alpha(P_{t,+}) \quad (\text{A48})$$

since operator norm convergence implies convergence in the weak operator topology. This concludes the proof. \square

Lemma 5. *The function $t \mapsto \alpha(P_{t,+} + P_{t,0})$ is continuous from the left.*

Proof. Let $\{t_n\}_{n \in \mathbb{N}} \subset [0, \infty)$ be a sequence of non-negative real numbers such that $t_n \uparrow t$ (i.e. t_n converges to t from below). Let A_n and A be the Hermitian operators defined by

$$A_n := \rho - t_n \sigma, \quad A := \rho - t \sigma \quad (\text{A49})$$

and note that $A - A_n = (t_n - t)\sigma \leq 0$ and $\|A_n - A\|_{op} \rightarrow 0$ as $n \rightarrow \infty$. It follows from the first part of Lemma 2 that

$$\|\{A_n < 0\} - \{A < 0\}\|_{op} \xrightarrow{n \rightarrow \infty} 0 \quad (\text{A50})$$

and thus, since operator norm convergence implies convergence in the weak operator topology, we have

$$\alpha(P_{t_n,+} + P_{t_n,0}) = \text{Tr}[\sigma(\mathbb{1} - \{A_n < 0\})] \xrightarrow{n \rightarrow \infty} \text{Tr}[\sigma(\mathbb{1} - \{A < 0\})] = \alpha(P_{t,+} + P_{t,0}). \quad (\text{A51})$$

This concludes the proof. \square

Lemma 6. *For $\alpha_0 \in [0, 1]$ we have the chain of inequalities*

$$\alpha(P_{\tau(\alpha_0),+}) \leq \alpha_0 \leq \alpha(P_{\tau(\alpha_0),+} + P_{\tau(\alpha_0),0}). \quad (\text{A52})$$

Proof. Recall that $\tau(\alpha_0) := \inf\{t \geq 0: \alpha(P_{t,+}) \leq \alpha_0\}$. Since, by Lemmas 3 and 4 the function $t \mapsto \alpha(P_{t,+})$ is non-decreasing and right-continuous, the left hand side of the inequality follows directly from the definition of $\tau(\alpha_0)$.

We now show the right hand side of the inequality. Note that if $t := \tau(\alpha_0) = 0$, then $P_{t,-} = \{\rho < 0\} = 0$ and thus $P_{t,+} + P_{t,0} = \mathbb{1}$ and $\alpha(P_{t,+} + P_{t,0}) = \text{Tr}[\sigma] = 1 \geq \alpha_0$. Suppose that $\tau(\alpha_0) > 0$ and let $\{t_n\}_{n \in \mathbb{N}} \subset [0, \infty)$ be a sequence of non-negative real numbers such that $t_n \uparrow \tau(\alpha_0)$. Note that, since $t_n < \tau(\alpha_0)$ for all n and $t \mapsto \alpha(P_{t,+})$ is non-increasing and right-continuous by Lemmas 3 and 4, we have

$$\text{Tr}[\sigma P_{t_n,+}] = \alpha(P_{t_n,+}) > \alpha_0 \quad (\text{A53})$$

by definition of $\tau(\alpha_0)$. Furthermore, since the projection $P_{t_n,0}$ is positive semidefinite, it follows that

$$\alpha(P_{t_n,+} + P_{t_n,0}) = \text{Tr}[\sigma(P_{t_n,+} + P_{t_n,0})] \geq \text{Tr}[\sigma P_{t_n,+}] = \alpha(P_{t_n,+}) > \alpha_0. \quad (\text{A54})$$

The Lemma now follows since by Lemma 5 the function $t \mapsto \alpha(P_{t,+} + P_{t,0})$ is continuous from the left and hence

$$\alpha(P_{\tau(\alpha_0),+} + P_{\tau(\alpha_0),0}) = \lim_{n \rightarrow \infty} \alpha(P_{t_n,+} + P_{t_n,0}) \geq \alpha_0 \quad (\text{A55})$$

which concludes the proof. \square

Construction of Helstrom Operators with Preassigned Type-I Error Probability

Given $\alpha_0 \in [0, 1]$, it follows from Lemma 6 that firstly $\alpha_0 - \alpha(P_{\tau(\alpha_0),+}) \geq 0$, and secondly, since $\alpha_0 - \alpha(P_{\tau(\alpha_0),+}) \leq \alpha(P_{\tau(\alpha_0),+} + P_{\tau(\alpha_0),0}) - \alpha(P_{\tau(\alpha_0),+})$ we have that

$$\frac{\alpha_0 - \alpha(P_{\tau(\alpha_0),+})}{\alpha(P_{\tau(\alpha_0),0})} \in [0, 1] \quad (\text{A56})$$

if $\alpha(P_{\tau(\alpha_0),0}) \neq 0$. It follows that, for any $\alpha_0 \in [0, 1]$, a Helstrom operator with type-I error probability α_0 is given by

$$M_{\tau(\alpha_0)} := P_{\tau(\alpha_0),+} + q_0 P_{\tau(\alpha_0),0}, \quad q_0 := \begin{cases} \frac{\alpha_0 - \alpha(P_{\tau(\alpha_0),+})}{\alpha(P_{\tau(\alpha_0),0})} & \text{if } \alpha(P_{\tau(\alpha_0),0}) \neq 0, \\ 0 & \text{otherwise.} \end{cases} \quad (\text{A57})$$

To see that $M_{\tau(\alpha_0)}$ indeed has type-I error probability α_0 , note that if $q_0 \neq 0$ then

$$\alpha(M_{\tau(\alpha_0)}) = \text{Tr}[\sigma M_{\tau(\alpha_0)}] = \text{Tr}[\sigma P_{\tau(\alpha_0),+}] + q_0 \text{Tr}[\sigma P_{\tau(\alpha_0),0}] = \alpha_0. \quad (\text{A58})$$

If on the other hand $q_0 = 0$, then, by Lemma 6, we have $\alpha_0 = \alpha(P_{\tau(\alpha_0),+}) = \alpha(M_{\tau(\alpha_0)})$.

3. Proof of Theorem 1

We first show the following Lemma which justifies the optimality of Helstrom measurements for asymmetric quantum hypothesis testing.

Lemma 7. *Let $t \geq 0$ and let $M_t := P_{t,+} + X_t$ for $0 \leq X_t \leq P_{t,0}$ be a Helstrom operator. Then, for any quantum hypothesis test $0 \leq M \leq \mathbb{1}$ for testing the null σ against the alternative ρ , the following implications hold*

- (i) $\alpha(M) \leq \alpha(M_t) \Rightarrow \beta(M) \geq \beta(M_t)$
- (ii) $\alpha(M) \geq 1 - \alpha(M_t) \Rightarrow 1 - \beta(M) \geq \beta(M_t)$

Proof. Let $\sum_i \lambda_i P_i$ be the spectral decomposition of the operator $\rho - t\sigma$ with orthogonal projections $\{P_i\}_i$ and associated eigenvalues $\{\lambda_i\}_i$. Recall that

$$P_{t,+} := \sum_{i: \lambda_i > 0} P_i \quad P_{t,-} := \sum_{i: \lambda_i < 0} P_i, \quad P_{t,0} := \mathbb{1} - P_{t,+} - P_{t,-}. \quad (\text{A59})$$

We notice that for any $0 \leq X_t \leq P_{t,0}$ we have

$$\text{Tr}[(\rho - t\sigma)X_t] = \text{Tr}[(\rho - t\sigma)P_{t,+}X_t] + \text{Tr}[(\rho - t\sigma)P_{t,-}X_t] \leq \text{Tr}[(\rho - t\sigma)P_{t,+}P_{t,0}] = 0 \quad (\text{A60})$$

and

$$\text{Tr}[(\rho - t\sigma)X_t] = \text{Tr}[(\rho - t\sigma)P_{t,+}X_t] + \text{Tr}[(\rho - t\sigma)P_{t,-}X_t] \geq \text{Tr}[(\rho - t\sigma)P_{t,-}P_{t,0}] = 0 \quad (\text{A61})$$

and thus $\text{Tr}[(\rho - t\sigma)P_{t,0}] = \text{Tr}[(\rho - t\sigma)X_t] = 0$. For the sequel, let $\bar{M}_t := \mathbb{1} - M_t$ and $\bar{M} := \mathbb{1} - M$.

We first show part (i) of the statement. Multiplying with the identity yields

$$M - M_t = (\bar{M}_t + M_t)M - M_t(\bar{M} + M) = \bar{M}_t M - M_t \bar{M} \quad (\text{A62})$$

and adding zero yields

$$\rho(M - M_t) = (\rho - t\sigma)(M - M_t) + t\sigma(M - M_t) \quad (\text{A63})$$

$$= (\rho - t\sigma)(\bar{M}_t M - M_t \bar{M}) + t\sigma(\bar{M}_t M - M_t \bar{M}). \quad (\text{A64})$$

We need to show that $\beta(M_t) - \beta(M) = \text{Tr}[\rho(M - M_t)] \leq 0$. Notice that

$$\text{Tr}[(\rho - t\sigma)\bar{M}_t M] = -\text{Tr}[(\rho - t\sigma)_- M] \leq 0 \quad (\text{A65})$$

and similarly

$$\text{Tr}[(\rho - t\sigma)M_t \bar{M}] = \text{Tr}[(\rho - t\sigma)_+ \bar{M}] \geq 0 \quad (\text{A66})$$

where the inequalities follow from $\mathbb{1} \geq M \geq 0$. Finally, we see that

$$\text{Tr}[\rho(M - M_t)] = \text{Tr}[(\rho - t\sigma)(\bar{M}_t M - M_t \bar{M})] + t \cdot \text{Tr}[\sigma(\bar{M}_t M - M_t \bar{M})] \quad (\text{A67})$$

$$\leq t \cdot \text{Tr}[\sigma(\bar{M}_t M - M_t \bar{M})] \quad (\text{A68})$$

$$= t \cdot \text{Tr}[\sigma(M - M_t)] \quad (\text{A69})$$

$$= t \cdot (\alpha(M) - \alpha(M_t)) \leq 0 \quad (\text{A70})$$

where the last inequality follows from the assumption and $t \geq 0$.

Part (ii) now follows directly from part (i) by noting that $0 \leq M' := \mathbb{1} - M \leq \mathbb{1}$ and

$$\alpha(M) \geq 1 - \alpha(M_t) \Rightarrow \alpha(M') \leq \alpha(M_t) \stackrel{(i)}{\implies} \beta(M_t) \leq \beta(M') = 1 - \beta(M). \quad (\text{A71})$$

This concludes the proof. \square

Theorem 1 (restated). *Let $\sigma, \rho \in \mathcal{S}(\mathcal{H})$ be benign and adversarial quantum states and let \mathbf{y} be a quantum classifier. Suppose that for $k_A \in \mathcal{C}$ and $p_A, p_B \in [0, 1]$ the classifier \mathbf{y} predicts class probabilities*

$$\mathbf{y}_{k_A}(\sigma) \geq p_A > p_B \geq \max_{k \neq k_A} \mathbf{y}_k(\sigma). \quad (\text{A72})$$

Let M_A^ and M_B^* be Helstrom operators for testing the null σ against the alternative ρ with type-I error probabilities $\alpha(M_A^*) = 1 - p_A$ and $\alpha(M_B^*) = p_B$. Then, if the type-II error probabilities satisfy*

$$\beta(M_A^*) + \beta(M_B^*) > 1 \quad (\text{A73})$$

it is guaranteed that $k_A = \arg \max_k \mathbf{y}_k(\rho)$, i.e. $\mathbf{y}_{k_A}(\rho) > \max_{k \neq k_A} \mathbf{y}_k(\rho)$.

Proof. Recall that we define quantum classifiers to be of the form $\mathbf{y}_k(\sigma) = \text{Tr}[\Pi_k \mathcal{E}(\sigma)]$ where \mathcal{E} is a CPTP map acting on the input spate and Π_k is a projective measurement. We can write \mathbf{y} in the Heisenberg picture as

$$\mathbf{y}_k(\sigma) = \text{Tr}[\mathcal{E}^\dagger(\Pi_k) \sigma] = \text{Tr}[F_k \sigma] \quad (\text{A74})$$

where $F_k := \mathcal{E}^\dagger(\Pi_k)$. Since \mathcal{E} is a CPTP map, its dual is completely positive and unital and thus $0 \leq F_k \leq \mathbb{1}$ and

$$\sum_k F_k = \sum_k \mathcal{E}^\dagger(\Pi_k) = \mathcal{E}^\dagger(\mathbb{1}) = \mathbb{1}. \quad (\text{A75})$$

Recall that by the reasoning in Section A.2, the operator defined by

$$M_{\tau(\alpha_0)} := P_{\tau(\alpha_0),+} + q_0 P_{\tau(\alpha_0),0}, \quad q_0 := \begin{cases} \frac{\alpha_0 - \alpha(P_{\tau(\alpha_0),+})}{\alpha(P_{\tau(\alpha_0),0})} & \text{if } \alpha(P_{\tau(\alpha_0),0}) \neq 0, \\ 0 & \text{otherwise.} \end{cases} \quad (\text{A76})$$

is a Helstrom operator with type-I error probability $\alpha_0 \in [0, 1]$. Let $M_A^* := M_{\tau(1-p_A)}$ be a Helstrom operator with $\alpha(M_{\tau(1-p_A)}) = 1 - p_A$ and notice that

$$\alpha(F_{k_A}) = \mathbf{y}_{k_A}(\sigma) \geq p_A = 1 - \alpha(M_A^*) \quad (\text{A77})$$

and thus, by the second part of Lemma 7, it follows that

$$\mathbf{y}_{k_A}(\rho) = 1 - \beta(F_{k_A}) \geq \beta(M_A^*). \quad (\text{A78})$$

Similarly, let $M_B^* := M_{\tau(p_B)}$ be a Helstrom operator with $\alpha(M_{\tau(p_B)}) = p_B$ and notice that for any $k \neq k_A$ we have

$$\alpha(F_k) = \mathbf{y}_k(\sigma) \leq p_B = \alpha(M_B^*) \quad (\text{A79})$$

and thus by the first part of Lemma 7 it follows that

$$\mathbf{y}_k(\rho) = 1 - \beta(F_k) \leq 1 - \beta(M_B^*). \quad (\text{A80})$$

Combining together inequalities (A78) and (A80) we see that if

$$\beta(M_A^*) + \beta(M_B^*) > 1, \quad (\text{A81})$$

it is guaranteed that

$$\mathbf{y}_{k_A}(\rho) > \max_{k \neq k_A} \mathbf{y}_k(\rho) \quad (\text{A82})$$

what concludes the proof. \square

4. Proof of Corollary 1

Corollary 1 (restated). *If σ and ρ are pure states then the robustness condition (8) is equivalent to*

$$T(\rho, \sigma) < \sqrt{\frac{1 - f(p_A, p_B)}{2}} \quad (\text{A83})$$

where $T(\rho, \sigma) = \frac{1}{2} \|\rho - \sigma\|_1$ is the trace distance between the benign and adversarial states, and

$$f(p_A, p_B) = \left\{ 1 - p_B - p_A(1 - 2p_B) + 2\sqrt{p_A p_B(1 - p_A)(1 - p_B)} \right\}^{\frac{1}{2}} \quad (\text{A84})$$

Proof. In order to prove the corollary, we show that the trace-distance bound in eq. (13) is equivalent to the robustness condition (8) from Theorem 1 expressed in terms of type-II error probabilities. For that purpose, we first derive an expression for the Helstrom operators in terms of the fidelity between ρ and σ and subsequently solve (8) for F . This is then related to the trace distance using Fuchs-van de Graaf. Recall that a Helstrom operator with type-I error probability α_0 takes the form (A57) which reads

$$M_{\tau(\alpha_0)} := P_{\tau(\alpha_0),+} + q_0 P_{\tau(\alpha_0),0}, \quad q_0 := \begin{cases} \frac{\alpha_0 - \alpha(P_{\tau(\alpha_0),+})}{\alpha(P_{\tau(\alpha_0),0})} & \text{if } \alpha(P_{\tau(\alpha_0),0}) \neq 0, \\ 0 & \text{otherwise.} \end{cases} \quad (\text{A85})$$

where $\tau(\alpha_0) := \inf\{t \geq 0: \alpha(P_{t,+}) \leq \alpha_0\}$. We now proceed as follows. We first compute the spectral decomposition of the operator $\rho - t\sigma$ as a function of t . With this, we derive an expression for $\alpha(P_{t,+})$ and subsequently compute $\tau(\alpha_0)$. This yields an expression for the Helstrom operators with type-I error probabilities $1 - p_A$ and p_B which can then be used to solve inequality (8) for the fidelity. We thus start by solving the eigenvalue problem

$$(\rho - t\sigma) |\eta\rangle = \eta |\eta\rangle. \quad (\text{A86})$$

Since σ and ρ are both pure states, we can write

$$\sigma = |\sigma\rangle\langle\sigma|, \quad \rho = |\rho\rangle\langle\rho| \quad (\text{A87})$$

and hence $(\rho - t\sigma)$ is of rank at most 2. It follows that there are at most two states $|\eta_0\rangle$ and $|\eta_1\rangle$ satisfying (A86) with nonzero eigenvalues and, in addition, they are linear combinations of $|\sigma\rangle$ and $|\rho\rangle$

$$|\eta_k\rangle = z_{k,\sigma} |\sigma\rangle + z_{k,\rho} |\rho\rangle, \quad k = 0, 1 \quad (\text{A88})$$

with constants $z_{k,\sigma}$ and $z_{k,\rho}$ that are to be determined. Substituting this into (A86) yields the system of equations

$$\begin{aligned} z_{k,\rho} + \gamma z_{k,\sigma} &= \eta_k z_{k,\rho} \\ -t\gamma^\dagger z_{k,\rho} - tz_{k,\sigma} &= \eta_k z_{k,\sigma} \end{aligned} \quad (\text{A89})$$

where $\gamma := \langle\rho|\sigma\rangle$ is the overlap between states ρ and σ . The two eigenvalues η_k for which these equations possess nonzero solutions are given by

$$\begin{aligned} \eta_0 &= \frac{1}{2}(1-t) + R, & \eta_1 &= \frac{1}{2}(1-t) - R, \\ R &= \sqrt{\frac{1}{4}(1-t)^2 + t(1-|\gamma|^2)} \end{aligned} \quad (\text{A90})$$

with $\eta_0 > 0$ and $\eta_1 \leq 0$. With the condition $\langle\eta_k|\eta_k\rangle = 1$, the coefficients $z_{k,\sigma}$ and $z_{k,\rho}$ are then determined as

$$\begin{aligned} z_{k,\rho} &= -\gamma A_k, & z_{k,\sigma} &= (1 - \eta_k) A_k, \\ |A_k|^{-2} &= 2R \left| \eta_k - 1 + |\gamma|^2 \right|. \end{aligned} \quad (\text{A91})$$

Recall that $P_{t,+} = \sum_{k: \eta_k > 0} P_k$ and hence $P_{t,+} = |\eta_0\rangle\langle\eta_0|$. We thus obtain the expression

$$\alpha(P_{t,+}) = \text{Tr}[\sigma P_{t,+}] = |\langle\eta_0|\sigma\rangle|^2 \quad (\text{A92})$$

$$= |z_{0,\sigma} + Z_{0,\rho}\gamma^*|^2 \quad (\text{A93})$$

$$= |A_0|^2 \left| 1 - \eta_0 - |\gamma|^2 \right|^2 \quad (\text{A94})$$

$$= \frac{\eta_0 - 1 + |\gamma|^2}{2R} \quad (\text{A95})$$

Substituting in the expressions for η_0 and R yields

$$\alpha(P_{t,+}) = \frac{\frac{1}{2}(1-t) + \sqrt{\frac{1}{4}(1-t)^2 + t(1-|\gamma|^2)} - 1 + |\gamma|^2}{2\sqrt{\frac{1}{4}(1-t)^2 + t(1-|\gamma|^2)}} = \frac{1}{2} \left(1 - \frac{1+t-2|\gamma|^2}{\sqrt{(1+t)^2 - 4t|\gamma|^2}} \right) \quad (\text{A96})$$

The next step is to compute $t_A = \tau(1 - p_A)$ and $t_B = \tau(p_B)$. By Lemma 3, the function $t \mapsto g(t) := \alpha(P_{t,+})$ is non-increasing and thus attains its maximum at $t = 0$

$$g(0) = \alpha(P_{0,+}) = |\gamma|^2 \quad (\text{A97})$$

Furthermore, note that the only real non-negative discontinuity of g is located at $t = 1$ in the case where $|\gamma|^2 = 1$. Since this corresponds to two identical states we exclude this case in the following and assume $|\gamma| \in [0, 1)$. Notice that, if $\alpha_0 \geq |\gamma|^2$, then we have that $\tau(\alpha_0) = 0$. Otherwise, if $\alpha_0 < |\gamma|^2$, then we have that $\alpha(P_{t,+}) = \alpha_0$ if $t \geq 0$ is the non-negative root of the polynomial

$$t \mapsto t^2 + 2t(1 - 2|\gamma|^2) + \left(1 - \frac{|\gamma|^2(1 - |\gamma|^2)}{\alpha_0(1 - \alpha_0)}\right) \quad (\text{A98})$$

which is calculated as

$$t = 2|\gamma|^2 - 1 - (2\alpha_0 - 1)\sqrt{\frac{|\gamma|^2(1 - |\gamma|^2)}{\alpha_0(1 - \alpha_0)}}. \quad (\text{A99})$$

Thus, in summary, we find that $\tau(\alpha_0)$ is given by

$$\tau(\alpha_0) = \begin{cases} 2|\gamma|^2 - 1 - (2\alpha_0 - 1)\sqrt{\frac{|\gamma|^2(1 - |\gamma|^2)}{\alpha_0(1 - \alpha_0)}} & \text{if } \alpha_0 < |\gamma|^2, \\ 0 & \text{if } \alpha_0 \geq |\gamma|^2. \end{cases} \quad (\text{A100})$$

First, we notice that if $|\gamma|^2 \leq \min\{p_B, 1 - p_A\}$, then we have $t_A = \tau(1 - p_A) = 0$ and $t_B = \tau(p_B) = 0$ and hence the robustness condition (8) cannot be satisfied. In the case where $\min\{p_B, 1 - p_A\} < |\gamma|^2 \leq \max\{p_B, 1 - p_A\}$, then either $t_A = 0$ or $t_B = 0$. Without loss of generality, suppose that $t_A = 0$. Then the Helstrom operator takes the form $M_A^* = \{\rho > 0\} + q_A(\mathbb{1} - \{\rho > 0\} - \{\rho < 0\})$ and thus

$$\beta(M_A^*) = 1 - \text{Tr}[\rho(\{\rho > 0\} + q_A(\mathbb{1} - \{\rho > 0\} - \{\rho < 0\}))] = 0. \quad (\text{A101})$$

In particular, it follows that the robustness condition $1 - \beta(M_B^*) < \beta(M_A^*)$ cannot be fulfilled. The same follows in the case where $t_B = 0$. Finally, if $|\gamma|^2 > \max\{p_B, 1 - p_A\}$, then we have that $t_A > 0$ and $t_B > 0$. We notice that $\alpha(P_{t_A,+}) = 1 - p_A$ and $\alpha(P_{t_B,+}) = p_B$ and thus $M_{\tau(1-p_A)} = P_{t_A,+}$ and $M_{\tau(p_B)} = P_{t_B,+}$. Computing the type-II error for $M_{\tau(1-p_A)}$ yields

$$\beta(M_{\tau(1-p_A)}) = 1 - \text{Tr}[\rho P_{t_A,+}] = 1 - |\langle \eta_0 | \rho \rangle|^2 = 1 - |A_0|^2 |\gamma|^2 |\eta_0|^2 \quad (\text{A102})$$

$$= |\gamma|^2 (2p_A - 1) + (1 - p_A) \left(1 - 2p_A \sqrt{\frac{|\gamma|^2(1 - |\gamma|^2)}{p_A(1 - p_A)}}\right) \quad (\text{A103})$$

where $|\eta_0\rangle$ corresponds to the eigenvector associated with the eigenvalue η_0 at $t = t_A$. Similarly, computing the type-II error for $M_{\tau(p_B)}$ yields

$$\beta(M_{\tau(p_B)}) = 1 - \text{Tr}[\rho P_{t_B,+}] = 1 - |\langle \eta_0 | \rho \rangle|^2 = 1 - |A_0|^2 |\gamma|^2 |\eta_0|^2 \quad (\text{A104})$$

$$= |\gamma|^2 (1 - 2p_B) + p_B \left(1 - 2(1 - p_B) \sqrt{\frac{|\gamma|^2(1 - |\gamma|^2)}{p_B(1 - p_B)}}\right) \quad (\text{A105})$$

where $|\eta_0\rangle$ corresponds to the eigenvector associated with the eigenvalue η_0 at $t = t_B$. With these expressions, it follows that the robustness condition (8), i.e. $\beta(M_{\tau(1-p_A)}) + \beta(M_{\tau(p_B)}) > 1$, is equivalent to

$$F(\rho, \sigma) > \frac{1}{2} \left(1 + \sqrt{1 - p_B - p_A(1 - 2p_B) + 2\sqrt{p_A p_B(1 - p_A)(1 - p_B)}}\right). \quad (\text{A106})$$

Finally, the fidelity is related to the trace distance via the Fuchs-van de Graaf inequality which in the case of two pure states leads to the equality

$$T(\rho, \sigma) = \sqrt{1 - F(\rho, \sigma)}. \quad (\text{A107})$$

With this relation, we arrive at a robustness condition expressed in terms of the trace distance $T(\rho, \sigma)$ which is given by

$$T(\rho, \sigma) < \sqrt{\frac{1}{2} \left(1 - \sqrt{1 - p_B - p_A(1 - 2p_B) + 2\sqrt{p_A p_B(1 - p_A)(1 - p_B)}}\right)}. \quad (\text{A108})$$

This concludes the proof. \square

5. Proof of Corollary 2

Corollary 2 (restated). *If $\sigma = |\sigma\rangle\langle\sigma|$ is a pure state but ρ can be a mixed state, then the robustness condition (8) implies the following sufficient condition for robustness, i.e. $k_A = \arg \max_k \mathbf{y}_k(\rho)$:*

$$T(\rho, \sigma) < \delta(p_A, p_B) \left(1 - \sqrt{1 - \delta(p_A, p_B)^2}\right), \quad (\text{A109})$$

where $\delta(p_A, p_B) = \sqrt{\frac{1-f(p_A, p_B)}{2}}$

Proof. We denote the convex hull enclosed by the set of robust pure states as $\mathcal{C} := \text{Conv}(\{|\psi\rangle\langle\psi| : \||\psi\rangle\langle\psi| - \sigma\|_1 < \delta(P_A, P_B)\})$. Observe that any convex mixture $\rho = \sum_i p_i |\psi_i\rangle\langle\psi_i|$ with $\sum_i p_i = 1$ of any sets of robust pure states $\{|\psi_i\rangle\langle\psi_i|\} \in \mathcal{C}$ must also be robust. Thus it suffices to prove condition (16) implies $\rho \in \mathcal{C}$. Note that the boundary consisting of non-extreme points (which correspond to mixed-states) of \mathcal{C} interfaces with the set $\mathcal{C}^* = \text{Conv}(\{|\psi^*\rangle\langle\psi^*| : \||\psi^*\rangle\langle\psi^*| - \sigma\|_1 = \delta(P_A, P_B)\})$. Thus, it suffices to compute the shortest distance r from σ to \mathcal{C}^* , such that $r = \min_{\rho^*} \|\rho^* - \sigma\|_1$ where $\rho^* \in \mathcal{C}^*$, then $\|\rho - \sigma\|_1 < r$ guarantees robustness. Further note that for every ρ^* , $\exists D_\sigma \rho^* D_\sigma^\dagger \in \mathcal{C}^*$, where $D_\sigma = 2\sigma - \mathbb{1}$, such that $\|\rho^* - \sigma\|_1 = \|D_\sigma \rho^* D_\sigma^\dagger - \sigma\|_1$, and $\|p_1 \rho^* + p_2 D_\sigma \rho^* D_\sigma^\dagger - \sigma\|_1 < \|\rho^* - \sigma\|_1$ for $p_1 + p_2 = 1$, and $p_1 \neq 0, p_2 \neq 0$. Therefore to minimise the distance to σ , it suffices to require $\rho^* = D_\sigma \rho^* D_\sigma^\dagger$, a valid of which is $\rho^* = \frac{1}{2}(|\psi^*\rangle\langle\psi^*| + D_\sigma |\psi^*\rangle\langle\psi^*| D_\sigma^\dagger)$. As such we have

$$\begin{aligned} r &= \|\sigma - \frac{1}{2}(|\psi^*\rangle\langle\psi^*| + D_\sigma |\psi^*\rangle\langle\psi^*| D_\sigma^\dagger)\|_1 \\ &= \||\psi^*\rangle\langle\psi^*| - \sigma + 2|\langle\sigma|\psi^*\rangle|^2 \sigma - \langle\sigma|\psi^*\rangle|\sigma\rangle\langle\psi| - \langle\psi|\sigma\rangle|\psi\rangle\langle\sigma|\|_1 \end{aligned} \quad (\text{A110})$$

Note that we have $\||\psi^*\rangle\langle\psi^*| - \sigma\|_1 = \delta(P_A, P_B)$ by definition and that

$$\begin{aligned} \|2|\langle\sigma|\psi^*\rangle|^2 \sigma - \langle\sigma|\psi^*\rangle|\sigma\rangle\langle\psi| - \langle\psi|\sigma\rangle|\psi\rangle\langle\sigma|\|_1 &= |\langle\sigma|\psi^*\rangle| \text{Tr} [|\sigma\rangle\langle\sigma| + |\psi^*\rangle\langle\psi^*| - \langle\sigma|\psi^*\rangle|\sigma\rangle\langle\psi^*| - \langle\psi^*|\sigma\rangle|\psi^*\rangle\langle\sigma|] \\ &= |\langle\sigma|\psi^*\rangle| \text{Tr} [(\sigma - |\psi^*\rangle\langle\psi^*|)(\sigma - |\psi^*\rangle\langle\psi^*|)^\dagger] \\ &= |\langle\sigma|\psi^*\rangle| \||\psi^*\rangle\langle\psi^*| - \sigma\|_1 \\ &= \delta(P_A, P_B) \sqrt{1 - \frac{\delta(P_A, P_B)^2}{4}}. \end{aligned} \quad (\text{A111})$$

Applying the reversed triangle inequality, we finally arrive at

$$\begin{aligned} r &\geq \|\|\sigma - |\psi^*\rangle\langle\psi^*|\|_1 - \|2|\langle\sigma|\psi^*\rangle|^2 \sigma - \langle\sigma|\psi^*\rangle|\sigma\rangle\langle\psi| - \langle\psi|\sigma\rangle|\psi\rangle\langle\sigma|\|_1 \\ &= \delta(P_A, P_B) \left(1 - \sqrt{1 - \frac{\delta(P_A, P_B)^2}{4}}\right). \end{aligned} \quad (\text{A112})$$

□

6. Robustness with Depolarised Input States

Corollary 3 (Depolarised single-qubit pure states). *Let $\sigma, \rho \in \mathcal{S}(\mathcal{H})$ be single-qubit pure states and let $\mathcal{E}_p^{\text{dep}}$ be a depolarising channel with noise parameter $p \in (0, 1)$. Then, if $p_A > 1/2$ and $p_B = 1 - p_A$, the robustness condition (8) for $\mathcal{E}_p^{\text{dep}}(\sigma)$ and $\mathcal{E}_p^{\text{dep}}(\rho)$ is equivalent to*

$$T(\rho, \sigma) < \begin{cases} \sqrt{\frac{1}{2} - \sqrt{\frac{2p_A(1-p_A) - p(1-\frac{1}{2}p)}{2(1-p)^2}}} & \text{if } \frac{1}{2} < p_A \leq \frac{4-6p+3p^2}{4-4p+2p^2}, \\ \sqrt{\frac{p \cdot (2-p) \cdot (1-2p_A)^2}{8(1-p)^2 \cdot (1-p_A)}} & \text{if } \frac{4-6p+3p^2}{4-4p+2p^2} < p_A \leq \frac{4-3p}{4-2p}, \\ 1 & \text{if } p_A > \frac{4-3p}{4-2p}. \end{cases} \quad (\text{A113})$$

Proof. In order to prove the corollary, we proceed in a manner analogous to the proof of Corollary 1. Specifically, we show that the condition on the fidelity and trace distance in eq. (A113) is equivalent to the robustness condition (8) from Theorem 1 expressed in terms of type-II error probabilities. Recall that the type-I and type-II error probabilities are given by

$$\alpha(M_t) = \text{Tr}[\sigma' M_t], \quad \beta(M_t) = \text{Tr}[\rho'(\mathbb{1} - M_t)]. \quad (\text{A114})$$

Let $\sigma' := \mathcal{E}_p^{\text{dep}}(\sigma)$ and $\rho' := \mathcal{E}_p^{\text{dep}}(\rho)$ and recall that a Helstrom operator for testing the null σ' against the alternative ρ' with type-I error probability α_0 takes the form (A57) which reads

$$M_{\tau(\alpha_0)} := P_{\tau(\alpha_0),+} + q_0 P_{\tau(\alpha_0),0}, \quad q_0 := \begin{cases} \frac{\alpha_0 - \alpha(P_{\tau(\alpha_0),+})}{\alpha(P_{\tau(\alpha_0),0})} & \text{if } \alpha(P_{\tau(\alpha_0),0}) \neq 0, \\ 0 & \text{otherwise.} \end{cases} \quad (\text{A115})$$

where $\tau(\alpha_0) := \inf\{t \geq 0: \alpha(P_{t,+}) \leq \alpha_0\}$. The robustness condition (8) is given by $\beta(M_A^*) + \beta(M_B^*) > 1$ where M_A^* and M_B^* are Helstrom operators with type-I error probabilities $\alpha(M_A^*) = 1 - p_A$ and $\alpha(M_B^*) = p_B$. Since $p_B = 1 - p_A$ by assumption, we have that $M_A^* = M_B^*$ and the robustness condition simplifies to $\beta(M_A^*) > 1/2$. We now proceed as follows. We first compute the spectral decomposition of the operator $\rho' - t\sigma'$ as a function of t and relate it to the fidelity between σ and ρ . With this, we derive an expression for $\alpha(P_{t,+})$ and subsequently compute $\tau(\alpha_0)$. This yields an expression for the Helstrom operator with type-I error probability $1 - p_A$ which can then be used to solve inequality (8) for the fidelity. We thus start by solving the eigenvalue problem

$$(\rho' - t\sigma')|\mu\rangle = \mu|\mu\rangle \quad (\text{A116})$$

which can be rewritten as

$$\left((1-p) \cdot (\rho - t\sigma) + \frac{p(1-t)}{2} \mathbb{1}_2 \right) |\eta\rangle. \quad (\text{A117})$$

We notice that the operators $\rho' - t\sigma'$ and $\rho - t\sigma$ share the same set of eigenvectors. Furthermore, if η is an eigenvalue of $\rho - t\sigma$ with eigenvector $|\eta\rangle$, then the corresponding eigenvalue μ of $\rho' - t\sigma'$ is given by

$$\mu = (1-p)\eta + \frac{p \cdot (1-t)}{2}. \quad (\text{A118})$$

From the proof of Corollary 1, we know that the eigenvalues of $\rho - t \cdot \sigma$ are given by

$$\begin{aligned} \eta_0 &= \frac{1}{2}(1-t) + R > 0, & \eta_1 &= \frac{1}{2}(1-t) - R \leq 0 \\ R &= \sqrt{\frac{1}{4}(1-t)^2 + t(1-|\gamma|^2)}, & \gamma &= \langle \rho | \sigma \rangle \end{aligned} \quad (\text{A119})$$

with eigenvectors

$$\begin{aligned} |\eta_0\rangle &= -\gamma A_0 |\rho\rangle + (1-\eta_0) A_0 |\sigma\rangle, & |\eta_2\rangle &= -\gamma A_2 |\rho\rangle + (1-\eta_2) A_2 |\sigma\rangle \\ |A_k|^{-2} &= 2R |\eta_k - 1 + |\gamma|^2|. \end{aligned} \quad (\text{A120})$$

where $\rho = |\rho\rangle\langle\rho|$ and $\sigma = |\sigma\rangle\langle\sigma|$. With this, we can compute the eigenvalues μ_k and eigenprojections P_k of $\rho' - t\sigma'$ as

$$\begin{aligned} \mu_0 &= (1-p)\eta_0 + p \cdot \frac{1-t}{2}, & \mu_1 &= (1-p)\eta_1 + p \cdot \frac{1-t}{2}, \\ P_0 &= |\eta_0\rangle\langle\eta_0|, & P_1 &= |\eta_1\rangle\langle\eta_1|. \end{aligned} \quad (\text{A121})$$

Since $\eta_0 > 0 \geq \eta_1$ for any $t \geq 0$, we have $\mu_0 \geq \mu_1$ and furthermore, the eigenvalues are monotonically decreasing functions of t for $|\gamma|^2 < 1$. To see this, consider

$$\frac{dR}{dt} = \frac{1+t-2|\gamma|^2}{2\sqrt{(1+t)^2 - 4t|\gamma|^2}} \quad (\text{A122})$$

and thus for $\forall t \geq 0$ and $|\gamma|^2 < 1$

$$\frac{d\mu_0}{dt} = \frac{dR}{dt} - \frac{1}{2} < 0 \quad \text{and} \quad \frac{d\mu_1}{dt} = -\frac{dR}{dt} - \frac{1}{2} < 0. \quad (\text{A123})$$

Hence, since both eigenvalues are strictly positive at $t = 0$, there exists exactly one ξ_k such that μ_k vanishes at ξ_k , $k = 0, 1$. Algebra shows that these zeroes are given by

$$\begin{aligned} \xi_0 &= 1 + \frac{2(1-|\gamma|^2)(1-p)^2}{p(2-p)} \left(1 + \sqrt{1 + \frac{p(2-p)}{(1-|\gamma|^2)(1-p)^2}} \right) > 1, \\ \xi_1 &= 1 + \frac{2(1-|\gamma|^2)(1-p)^2}{p(2-p)} \left(1 - \sqrt{1 + \frac{p(2-p)}{(1-|\gamma|^2)(1-p)^2}} \right) < 1. \end{aligned} \quad (\text{A124})$$

We define the functions

$$g_0(t) := \langle \eta_0 | \sigma' | \eta_0 \rangle = \frac{1}{2} \left(1 + \frac{(1-p)(2|\gamma|^2 - 1 - t)}{\sqrt{(1+t)^2 - 4t|\gamma|^2}} \right), \quad (\text{A125})$$

$$g_1(t) := \langle \eta_1 | \sigma' | \eta_1 \rangle = \frac{1}{2} \left(1 - \frac{(1-p)(2|\gamma|^2 - 1 - t)}{\sqrt{(1+t)^2 - 4t|\gamma|^2}} \right), \quad (\text{A126})$$

$$f_0(t) := \langle \eta_0 | \rho' | \eta_0 \rangle = \frac{1}{2} \left(1 + \frac{(1-p)(1+t) \cdot (1-2|\gamma|^2)}{\sqrt{(1+t)^2 - 4t|\gamma|^2}} \right), \quad (\text{A127})$$

$$f_1(t) := \langle \eta_0 | \rho' | \eta_0 \rangle = \frac{1}{2} \left(1 - \frac{(1-p)(1+t) \cdot (1-2|\gamma|^2)}{\sqrt{(1+t)^2 - 4t|\gamma|^2}} \right). \quad (\text{A128})$$

With this, we now compute $t \mapsto \alpha(P_{t,+})$ as

$$\alpha(P_{t,+}) = \text{Tr}[\sigma' P_{t,+}] = \begin{cases} 1 & 0 \leq t < \xi_1 \\ g_0(t) & \xi_1 \leq t < \xi_0 \\ 0 & \xi_0 \leq t \end{cases} \quad (\text{A129})$$

For $\alpha_0 \in [0, 1]$, we compute $\tau(\alpha_0) := \inf\{t \geq 0: \alpha(P_{t,+}) \leq \alpha_0\}$ as

$$\tau(\alpha_0) = \begin{cases} \xi_0 & 0 \leq \alpha_0 \leq g_0(\xi_0) \\ g_0^{-1}(\alpha_0) & g_0(\xi_0) < \alpha_0 < g_0(\xi_1) \\ \xi_1 & g_0(\xi_1) \leq \alpha_0 < 1 \\ 0 & \alpha_0 = 1 \end{cases} \quad (\text{A130})$$

where

$$g_0^{-1}(\alpha_0) = 2|\gamma|^2 - 1 + 2(1 - 2\alpha_0) \sqrt{\frac{|\gamma|^2(1 - |\gamma|^2)}{p(2-p) - 4\alpha_0(1 - \alpha_0)}}. \quad (\text{A131})$$

To solve condition (8) we now have to distinguish different cases, depending on which interval $1 - p_A$ falls into. Firstly, if $1 - p_A = 1$, then $\tau(1 - p_A) = 0$ and thus $\beta(M_A^*) = 0$ in which case the condition can not be satisfied. If $1 - p_A \in [g_0(\xi_1), 1)$, then we have $\tau(1 - p_A) = \xi_1$. In this case, it holds that $\mu_0 > 0$ and $\mu_1 = 0$ and the Helstrom operator is given by

$$M_A^* = |\eta_0\rangle\langle\eta_0| + \frac{1 - p_A - g_0(\xi_1)}{g_1(\xi_1)} |\eta_1\rangle\langle\eta_1| \quad (\text{A132})$$

and the robustness condition reads

$$\beta(M_A^*) = 1 - f_0(\xi_1) - \frac{1 - p_A - g_0(\xi_1)}{g_1(\xi_1)} f_1(\xi_1) > \frac{1}{2} \quad (\text{A133})$$

which cannot to be satisfied simultaneously with $1 - p_A \in [g_0(\xi_1), 1)$. If, on the other hand $1 - p_A \in (g_0(\xi_0), g_0(\xi_1))$, then $\tau(1 - p_A) = g_0^{-1}(1 - p_A)$ and $\mu_0 > 0 > \mu_1$. The Helstrom operator then is given by $M_A^* = |\eta_0\rangle\langle\eta_0|$ which leads to the robustness condition

$$1 - f_0(g_0^{-1}(1 - p_A)) > \frac{1}{2} \quad (\text{A134})$$

which, together with $1 - p_A \in (g_0(\xi_0), g_0(\xi_1))$, is equivalent to

$$|\gamma|^2 > \frac{1}{2} \left(1 + \sqrt{\frac{4p_A(1 - p_A) - p(2 - p)}{(1 - p)^2}} \right), \quad \frac{1}{2} \leq p_A \leq \frac{4 - 6p + 3p^2}{4 - 4p + 2p^2}. \quad (\text{A135})$$

In the last case where $1 - p_A \leq g_0(\xi_0)$, we have $\tau(1 - p_A) = \xi_0$ and thus $\mu_0 = 0 > \mu_1$. The Helstrom operator is then given by $\frac{1-p_A}{g_0(\xi_0)}|\eta_0\rangle\langle\eta_0|$, leading to the robustness condition

$$1 - \frac{1 - p_A}{g_0(\xi_0)} f_0(\xi_0) > \frac{1}{2}. \quad (\text{A136})$$

Together with $1 - p_A \leq g_0(\xi_0)$ this is equivalent to

$$|\gamma^2| > \begin{cases} \frac{4p_A(1-p_A)-p(2-p)}{(1-p)^2(4(1-p_A)-p(2-p))}, & \text{if } \frac{1+(1-p)^2}{2} < p_A \leq \frac{4-6p+3p^2}{4-4p+2p^2} \\ \frac{(4-3p-2p_A(2-p))(2-p(3-2p_A))}{8(1-p)^2(1-p_A)}, & \text{if } \frac{4-6p+3p^2}{4-4p+2p^2} < p_A \leq \frac{4-3p}{4-2p}, \\ 0, & \text{if } p_A > \frac{4-3p}{4-2p}. \end{cases} \quad (\text{A137})$$

Finally, combining together conditions (A135) and (A137) leads to

$$|\gamma^2| > \begin{cases} \frac{1}{2} \left(1 + \sqrt{\frac{4p_A(1-p_A)-p(2-p)}{(1-p)^2}} \right), & \text{if } \frac{1}{2} < p_A \leq \frac{4-6p+3p^2}{4-4p+2p^2} \\ \frac{(4-3p-2p_A(2-p))(2-p(3-2p_A))}{8(1-p)^2(1-p_A)}, & \text{if } \frac{4-6p+3p^2}{4-4p+2p^2} < p_A \leq \frac{4-3p}{4-2p}, \\ 0, & \text{if } p_A > \frac{4-3p}{4-2p}. \end{cases} \quad (\text{A138})$$

Since by assumption ρ and σ are pure states the proof is completed by noting that we have

$$T(\rho, \sigma) = \sqrt{1 - F(\rho, \sigma)} \quad (\text{A139})$$

by the Fuchs-van de Graaf inequality. \square