

A Software-Defined Networking Solution for Transparent Session and Service Continuity in Dynamic Multi-Access Edge Computing

Pablo Fondo-Ferreiro, Felipe Gil-Castiñeira, Francisco J. González-Castaño, David Candal-Ventureira
atlanTTic Research Center, University of Vigo
E.E. Telecomunicación, Rúa Maxwell s/n, Campus, 36310 Vigo, Spain.
Tel.:+34 986 818684; email: {pfondo,xil,javier,dcandal}@gti.uvigo.es

Abstract

Multi-Access Edge Computing (MEC) is one of the prominent 5G concepts that will allow service requirements that were not feasible so far due to the high communications latency and rigidity of cellular networks. The ETSI and the 3GPP are working towards the standardization of MEC applications integration in 5G networks, and how to route user traffic to a Local Area Data Network where local applications are deployed. Nevertheless, there are no practical implementations that facilitate the dynamic relocation of applications from the core to a MEC host, or from a MEC host to another without interruption and transparently to User Equipment (UE). Furthermore, the MEC concept can also be included in a 4G network to provide new advanced services with existing infrastructures. In this paper we propose to use Software-Defined Networking (SDN) to create a new instance of the IP anchor point to dynamically redirect the UE traffic to a new physical location (e.g. an edge infrastructure) while maintaining session and service continuity. We also present a novel, completely distributed approach based on SDN to maintain the previous context of the connection in the new instance of the IP anchor point, and we analyze the performance of this mechanism in comparison to other possible alternatives to keep the session state. This approach can be used to implement edge services in a 4G or 5G network.

Index terms— 5G, Edge, MEC, SDN

1 Introduction

5G networks include technology improvements that provide low latency and improve flexibility, agility, and network and context awareness to increase the Quality of Experience (QoE) of end users [1]. Virtualization and cloud computing have proved to be essential tools to build flexible and

efficient architectures but the traditional centralized mode has limitations in terms of availability, performance, scalability, latency, etc. Hence the efforts to take cloud capabilities to the network edge in different approaches such as Fog Computing, cloudlets, and the MEC paradigm.

MEC is specially relevant in 5G scenarios, as it was specifically designed by ETSI for mobile communications environments. In 2014 the ETSI launched the Mobile Edge Computing Industry Specification Group (MEC ISG) to standardize the integration of third party applications in multi-vendor platforms at the edge of mobile networks [2]. This group defined a framework and reference architecture and a set of APIs. It considered that MEC components and Mobile Edge (ME) applications would be implemented on top of the Network Functions Virtualization (NFV) architecture to share the same infrastructure and management functions. This would allow operators to maximize the return of the investments in virtualization [3], and at the same time provide new services that were not feasible before, such as high-quality augmented reality image generation at the edge (with graphic engines that cannot be embedded in smartphones nowadays) and low-latency remote gaming.

In [4] the ETSI studied how a MEC system can be deployed into 4G architectures, and described one of the main challenges that should be addressed: how to route IP packets to MEC applications in a distributed architecture. This traffic steering is closely related to the location of the MEC infrastructure, and the document describes five different alternatives:

- “Bump in the wire”: The MEC platform is installed between the base station and the core network. The MEC platform can be part of the eNB. In that case the system can decide if packets have to be routed to the local MEC application or if they have to be encapsulated using the GTP (GPRS Tunneling Protocol) protocol and sent to the Serving Gateway (S-GW). Alternatively, the MEC platform can be located somewhere on the S1 interface. If so, it is necessary to handle user traffic encapsulated in GTP-U packets.
- Distributed EPC: The MEC includes all or part of the 3GPP Evolved Packet Core (EPC) components. This way, the MEC controls the PDN Gateway (P-GW), which is the point of entry/exit of traffic for the UE, and can handle the DNS to provide the local IP of the MEC application.
- Distributed S/P-GW: Instead of deploying the complete EPC, only the S-GW and the P-GW are deployed at the edge site. The selection of the S/P-GW is performed by the central MME based on the location of the UE.
- Distributed S-GW with Local Breakout (SGW-LBO): In this case it is possible to select if the user traffic should reach MEC applications or core applications in a selective manner.
- Control/User Plane Separation (CUPS): 3GPP Release 14 standardized the CUPS paradigm, separating the control and user planes. This new architecture can be used to distribute the EPC gateways at the edge.

These alternatives must address several challenges. For example, the different components have to be *MEC aware* in order to manage the session and perform the right traffic routing for each UE, and the MEC needs to be aware of the mobility of the UE to maintain service continuity, even performing MEC handovers (which may result in a service interruption). ETSI also points out that the system should be able to relocate a mobile edge application between a cloud environment and

a MEC host, but they note that this is still an open issue [5]. In this paper we propose a solution for this problem.

MEC can be integrated in a 4G network by following one of the previous alternatives, but in 5G it has been identified as one of the key technologies for supporting low latency since the beginning. Therefore, the 5G system specification defines the enablers for edge computing, and its Service Based Architecture (SBA) facilitates the deployment and integration of MEC. Other recent ETSI white paper [6] departs from this architecture to analyze the challenges MEC will face in 5G networks, such as traffic steering and UE and application mobility. That is, when a MEC application is instantiated, the traffic from a particular UE has to be directed to that application to take advantage from its location. Also, when the user moves to a new location, the application and its traffic should also move to the closer MEC infrastructure.

Summing up, current proposals to integrate MEC in 4G networks require a complex setup where the different components, such as the gateways, must be aware of their location. Furthermore, 4G and 5G networks have also to be designed to steer the traffic to the most appropriate application, located in the core or in any of the different MEC infrastructures, in order to achieve the required latency or any other feature that benefits from the proximity between the UE and the application.

In this paper we take advantage of virtualization and SDN to propose an architecture that can be used to steer UE traffic to the core of the network or to one of the MEC infrastructures. The destination of the traffic may change dynamically, in case the UE moves, the state of the network changes, the application is relocated, or the requirements of the UE are different. To achieve this objective, we create new instances of the P-GW (the termination point of UE traffic) in the desired location (core or MEC infrastructure). Nevertheless, since the P-GW has a state, the user context must also be transferred. Therefore we also have designed and evaluated a new mechanism to transfer and synchronize P-GW contexts between the original instance and the new one using SDN. This mechanism is completely transparent for the UE and the P-GW, not requiring any kind of modification or adaptation. In addition, as shown in our Proof of Concept (PoC) implementation, this proposal can be used to easily integrate MEC infrastructures in 4G networks.

2 Related Work

MEC technology is considered a key 5G enabler. The idea behind is to provide IT service environments and cloud-computing capabilities at the edge of the mobile network in close proximity to mobile subscribers. One of its main goals is latency reduction, which has been identified as one the key requirements of 5G networks [7].

MEC implementations involve several functions described in the 3GPP specification of the 5G system architecture [8]. For example, the architecture allows concurrent access to different data networks (e.g., a central and a local –or edge– data network), and it is possible to define rules to send the traffic to the IP anchor points (or User Plane Function –UPF– in 5G terminology) connected to the different Data Networks (DNs). The 5G Core Network may select a UPF and execute the traffic steering to a DN based on UE’s subscription data, location, or following a request from the Application Function (AF). The AF can influence traffic routing via a request to the Session Management Function (SMF), including requesting traffic steering for single UEs or groups of them in particular areas or locations. The “UL CL” (Uplink classifier) or the IPv6 multi-homing functionalities can be used to divert traffic according some traffic matching traffic filters, but the mechanisms that enable traffic steering in the local access to the DN are not defined

in the standard. Applications can also indicate that they can be relocated, or that they should be notified about certain traffic events or the traffic of UEs in a particular location. Finally, the session and service continuity features can be used to enable UE and application mobility.

Thus, the 3GPP specification of 5G system architecture provides a detailed description of the required functions to implement MEC in 5G and how they operate, but many mechanisms are still not defined in detail. Also, although the standard allows UEs to select a session and service continuity mode to ensure an uninterrupted service, this may require the active collaboration from the UE to maintain the connectivity when the IP address changes or a new application server is selected. Therefore, dynamic relocation of applications would not be possible without the collaboration of the UE. Our proposal, which includes a practical implementation of a MEC architecture with SDN, allows applications to be relocated dynamically, as it makes possible to deploy new UPFs in different locations keeping the IP address and the connection transparently to the UE.

As introduced in Section 1, integrating the MEC architecture in 4G networks may also be of value, and the ETSI and other researchers are studying this topic. For example, in [9], the authors emphasize its interest for creating a common layer of integration for the Internet of Things (IoT). At a rather conceptual level, including a discussion of possible use cases, they mention server/proxy Domain Name Server (DNS) configuration as a way to redirect traffic to edge applications. Therefore, they do not consider the possible role of SDN technology as an enabler. They also mention that MEC standardization is still at a very early stage and that it should be coordinated with ETSI NFV standardization (the ETSI, indeed, is driving MEC standardization and implementation with different white papers, proofs of concept to demonstrate the MEC concept, Group Reports (GR) and Group Specifications (GS)¹).

Other researchers, instead of following the standardization, have studied how SDN, NFV and cloud technologies could be used for mobile edge applications and innovative services. For example, the mobile networks branch of Central Office Re-architected as Datacenter (CORD) [10], M-CORD [11], built a SDN scalable connectionless core with these technologies. This way, they sought to reduce the excessive signaling overhead in Long Term Evolution (LTE) networks. However, the connectionless approach they proposed required modifying the EPC entities.

Telecommunication operators have also shown interest in leveraging NFV and SDN technologies to improve the capacity of EPCs in a cost-effective way. The PoC in [12], whose results have been published in the wiki of the ETSI ISG for NFV [13], demonstrated an EPC SGW and a PGW based on SDN and NFV technologies that splitted the control and user planes, in which the control plane resided in the SDN controller and the user plane in an SDN fabric. This preserved GTP-Control Plane (GTP-C) and GTP-User Plane (GTP-U) protocols from the points of view of the eNB and the Mobility Management Entity (MME). The PoC illustrated how operator network rules can be managed with SDN. Our approach also relies on SDN to handle user traffic.

Regarding SDN control of packet cores, in [14], the authors, who participate in the Wireless & Mobile Working Group of the Open Networking Foundation (ONF), pointed out the flexibility and elasticity shortcomings of current architectures. They defined Openflow extensions to handle Packet Data Network (PDN) connections while keeping Quality of Service (QoS) support, accounting and online charging. More specifically, they identified the need of two extensions of the OpenFlow protocol to manage GTP-U packets, matchings and actions. We have not followed this approach because at the time this paper was written, such extensions of the OpenFlow protocol were not implemented. Moreover, we do not consider the possibility of modifying the OpenFlow protocol,

¹<https://portal.etsi.org/tb.aspx?tbid=826&SubTB=826>

since it is not guaranteed that such approach would be included in the OpenFlow standard, nor in SDN controller updates of existing devices.

There exist different proposals for diverting traffic in 5G networks. In [15], the authors introduced a virtualized Evolved Packet Core (EPC) gateway that dynamically switched the data plane for each user to a fast-path dedicated element near the evolved node B (eNB), using an OpenFlow gateway with General Packet Radio System Tunneling Protocol (GTP) extensions that kept active sessions. Since GTP is not supported in the OpenFlow protocol natively, the authors needed a workaround to analyze the content of the packets inside GTP-U tunnels. As described in [16], this is still under discussion and has not been standardized yet. In [17], the authors also identified the need of analyzing traffic inside GTP-U tunnels. They applied a patch to Open VSwitch (OVS) devices that is not fully compatible with OpenFlow [18], so they programmed the flows by setting Secure Shell (SSH) connections with the devices. They concluded that further work is necessary to integrate SDN in 5G networks with the desired flexibility.

Therefore, previous approaches leveraged SDN flexibility for diverting the traffic of specific users to the network edge. Some of these approaches have identified the need to analyze the content inside GTP-U tunnels in the Radio Access Network (RAN), which is not directly available to SDN devices. To overcome this limitation, it has been proposed to apply patches to OVS that allow encapsulating and decapsulating the GTP-U protocol. We have selected this same feasible approach for its satisfactory performance.

Edge intelligence has been highlighted as a key aspect to achieve low-latency 5G communications for applications such as self-driving vehicles, industrial automation, tele-medicine, Virtual Reality (VR) and Augmented Reality (AR) [19]. Unlike the previous approaches that have simply considered traffic redirection to specific applications running on edge servers, we propose to deploy the S/P-GW at the network edge and reconfigure the network dynamically to *move* some users or flows to the new S/P-GW instance, thus reducing latency and congestion in the core network. To achieve that goal, the state of the original S/P-GW must be replicated in the new S/P-GW transparently to 3GPP protocols, which, as stated in [16], have not been designed with such flexibility in mind. State replication of mobile network functions (mainly control plane entities, such as the MME) has already been explored in the literature, using the classical three-layered architecture with a load balancer front-end; a layer of stateless workers and a database layer with session context information [20,21]. In [22] this database layer was removed by embedding the state in the workers. Obviously, this two-layer approach required proactive state synchronization among the workers, which was solved with a custom protocol over TCP, and it still introduces delay to retrieve the state, compromising ultra low latency requirements.

Generic state replication for mobile edge clouds has already been addressed. In [23], the authors presented a layered framework for migrating active applications of virtual machines or containers. It involved dumping the entire RAM memory of the source entity, transferring it to the target and restoring it at destination. The MEC proposal in [24] described EPC-as-a-service stateful components, as well as a method to keep states among different EPC instances that replicated the whole EPC, that is the MME, the S/P-GW and the Home Subscriber Server (HSS).

Summing up, previous state replication schemes imposed high latencies and overheads.

In this work, therefore, we propose a low-latency MEC computing solution that migrates S/P-GW modules to the edge without interrupting user sessions. It keeps the state of S/P-GW modules by simply replicating 3GPP messages. Unlike previous approaches, it is generic, efficient and compatible with all communication and network management standards involved. State replication is

lightweight and fully distributed.

We close this section with a note on Low Latency Multi-Access Edge Computing (LL-MEC) [25], an open source control plane platform for MEC applications part of the Mosaic5G project [26] in which SDN switches carry out the user plane. Even though it has similarities with our proposal, it is obviously not intended for interoperability with existing core network entities, since these are completely replaced by new ones.

3 Problem Statement

5G networks will support a rich variety of services, many of them with stringent latency requirements (e.g. high quality augmented reality renderings, real time teleoperation, etc.). At some point a connection through the core network will be unable to satisfy one of such demands, so it will be necessary to make use of the MEC system and deploy the service at the edge, at a location that will be closer to the user. That may even be a dynamic scenario, in which a service that was initially instantiated in the core of the network should be relocated at the edge.

Our main goal is to provide a seamless solution for this scenario. If the latency of some particular flow is too high, it will be necessary to take the IP connection termination to a location with a lower transmission delay, yet we wish to attain so without any session interruption. Besides, we assume that custom network functions that are aware of the location of the applications are not desirable. To achieve our goal we dynamically deploy a new virtualized S/P-GW module at the network edge (i.e. close to the users), and reprogram the network automatically in a fully distributed way by relying on the SDN paradigm, to divert the flows dynamically to the replicated S/P-GW.

We remark that we seek to leverage current network entities without any modification, and to respect 3GPP and control management protocols as they are. This way, our proposal could be quickly deployed in a real network.

We have identified two key challenges that must be addressed:

- S/P-GW replication
- Diverting traffic at individual user level

Since we want to keep existing connections undisturbed, the existing S/P-GW should continue operating all of them except those we *move* to the edge. Then we need to replicate the S/P-GW, so that multiple S/P-GWs will be available in the network. A first barrier is that, at the moment of writing this paper, Evolved Packet Core implementations such as that by the OpenAirInterface Software Alliance² did not allow the same MME to manage multiple S/P-GWs nor multiple S/P-GWs to be connected to the same eNodeB. Even though the LTE standard considers this last possibility, it is only considered a static setting in which each UE is assigned an S/P-GW at connection establishment. Besides, the original S/P-GW has a context for each user, which identifies how the user traffic should be exchanged with the eNodeB through the S1-U interface. This traffic is encapsulated using the GTP-U protocol. The MME manages the endpoints of this tunnel using the GTP-C protocol, which communicates with the S/P-GW through the S11 interface.

Thus, somehow, the newly deployed S/P-GW must have access to that context information to be able to handle the packets of the users. That is to say, the context of the original S/P-GW must be replicated into the new one for the latter to establish the tunnels and become fully operational.

²<http://www.openairinterface.org/>

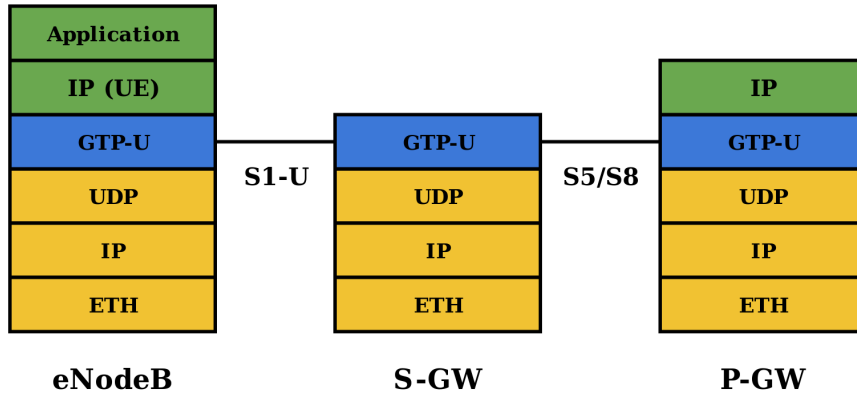

Figure 1: GTP-U protocol stack in EPC interfaces.

On the other hand, we want to divert the traffic of specific users to the edge of the network, i.e. as soon as possible once the eNodeB transmits the packets. At this point, they are encapsulated with GTP headers where the outer IP headers of the packet correspond to the endpoints of the GTP-U tunnel: the eNodeB and the S/P-GW. Therefore, the UEs cannot be identified by only analyzing the outer IP or UDP headers, as they will be identical for all users connected to the same eNodeB. To divert the traffic of specific UEs, inner IP packets inside the GTP tunnels (i.e., the packets sent by the UE) must be analyzed. Figure 1 shows the GTP-U protocol stack, as used in the S1-U and S5/S8 interfaces of the EPC, to help the reader visualize this problem.

4 Proposed Solution

We propose an SDN based architecture that is able to dynamically change the endpoint of a IP connection for a particular UE. It makes it possible to deploy applications at the edge, and even to relocate applications that were previously running in other locations.

First, we include an SDN device in the architecture to handle the communications between the RAN and the EPC (HSS, MME and S/P-GW) as shown in Fig. 2. Initially, an SDN controller manages the forwarding decisions of the device with a simple reactive learning application.

Then, we implement a framework for edge-assisted latency reduction with two modules: (i) an application that dynamically deploys a new S/P-GW entity and (ii) an SDN application that replicates the state of the S/P-GW and configures the SDN fabric to divert the traffic of specific UE flows.

The workflow of the solution is as follows:

1. The module in charge of deploying S/P-GWs dynamically launches a new S/P-GW Virtual Machine (VM) at the edge of the network. This is performed via REST API exposed by OpenStack using Heat Orchestration Templates (HOT).
2. Once the S/P-GW VM is up and running, the SDN application is called via REST API exposed through the SDN controller.

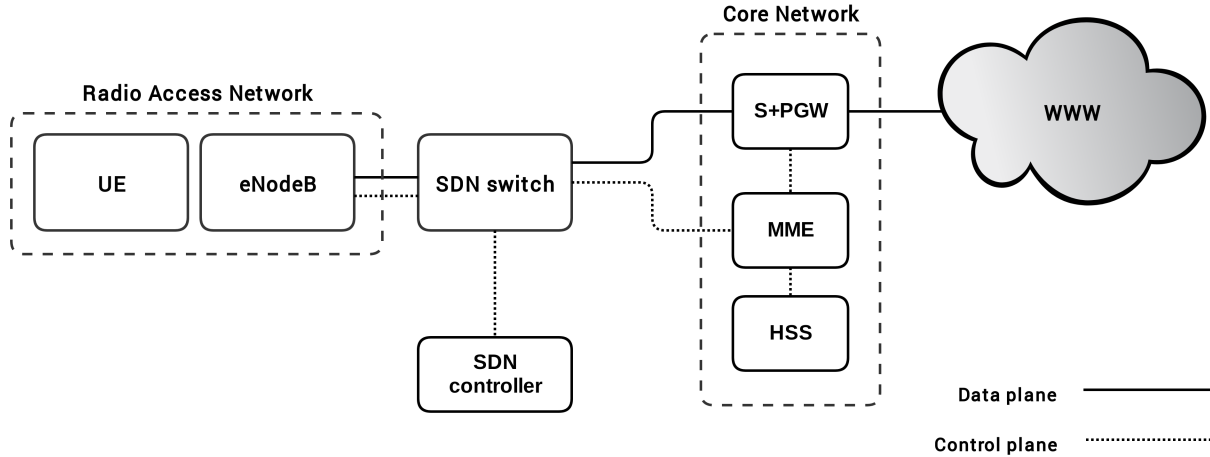

Figure 2: SDN switch connecting RAN and EPC.

3. The SDN application then replicates the state of the original S/P-GW into the newly created S/P-GW.
4. Once the state has been replicated, the SDN controller instructs the SDN device that communicates the eNodeB with the EPC to divert the traffic of the specific users that must be migrated to the new S/P-GW to meet their traffic requirements.

The following subsections describe in detail how we have addressed S/P-GW replication and diverting traffic at individual user level.

4.1 S/P-GW replication

Our solution launches an S/P-GW VM in a server located in a datacenter that is physically close to the eNodeB to which the UE is connected. The first challenging step is making this replicated S/P-GW fully operational. As we have previously mentioned, the replicated S/P-GW must have access to the state of the original S/P-GW. As discussed in Section 2, the proposals in the literature either employ fully stateless modules whose state information is centralized in an external database or keep the state inside the modules but must synchronize their states (and thus need custom modules with an ad-hoc signaling protocol). Our goal is to address this step without any centralized ad-hoc element and transparently to EPC network entities.

Note that the S/P-GW is a reactive entity. In particular, after analyzing it as well as the protocols involved in the EPC network, we found out that its internal state is completely determined by the messages it receives from the MME. The latter is in charge of instructing the S/P-GW to establish data path GTP-U tunnels (S1-U interface) with the eNodeBs. Therefore, we propose to replicate the state of the original S/P-GW by sending to the newly deployed one the same GTP-C messages that the MME sent to the original S/P-GW.

To accomplish this, the SDN controller stores the GTP-C messages that the MME sent to the original S/P-GWs. When the SDN controller is instructed to replicate into a newly deployed S/P-

GW the state of the original S/P-GW, the SDN controller sends to the new S/P-GW all those messages. From this moment on, any GTP-C message that the MME sends to the original S/P-GW (which is also received at the SDN controller), is sent to the new S/P-GWs as well.

This process requires the GTP-C messages sent by the MME to be forwarded through the SDN controller. We have addressed this by creating a lightweight OVS switch in the MME virtual machine, with just one port besides the LOCAL one. This OVS will treat all non-GTP-C packets in a completely transparent way, by sending those received at the LOCAL port to the other port and vice versa. A high-priority flow rule is installed in this switch, so that the GTP-C packets sent by the MME are forwarded through the SDN controller. In addition, another high-priority flow rule is also installed when the traffic diversion is enabled, so that the GTP-C packets generated by replicated S/P-GWs that are addressed to the MME will be discarded. This way, replicated S/P-GWs will be completely transparent to the original mobile network entities.

4.2 Diverting traffic at individual user level

The packets at the network edge are encapsulated inside GTP-U tunnels. Redirecting the traffic of all the users to the replicated S/P-GW would be fairly simple: we could simply set a flow rule in the switch that is closer to the eNodeB to match all GTP-U traffic (i.e. UDP traffic for port 2152 [27]) that is addressed to the original S/P-GW and replace the destination IP and MAC addresses by those of the replicated S/P-GW.

However, we are interested in only diverting the traffic of specific users, applications or even the traffic between specific users. Since the packets are GTP-U-encapsulated, user-specific information is contained inside the GTP-U header. To differentiate users it is necessary to match the IP addresses of the inner IP header. At the time this paper was written, the OpenFlow protocol [28] could not match fields in layers above the transport protocol (UDP in this case). Our solution consists in encapsulating and decapsulating GTP-U packets in the switch to access the inner UE IP packets. After analyzing several options to implement this we chose Open vSwitch (OVS) [29], the most extended OF-enabled switch. OVS defines special tunnel ports that allow encapsulating and decapsulating packets. Its current version supports tunnels such as VXLAN, GRE and LISP, but not GTP. However, the open source patch at [30,31] (also used in the LL-MEC platform [25]) extends OVS to support GTP tunnel ports in the same way as natively supported tunnels, leveraging the GTP linux kernel module.

The patch allows us creating an OVS switch that is directly connected to the eNodeB through a virtual GTP port that decapsulates inbound GTP packets and encapsulates outbound ones. When a packet is encapsulated, the destination endpoint of the GTP tunnel can be set in a flow by using OVS extensions that are fully supported by OpenFlow and most SDN controllers, such as ONOS. Our proposed solution uses three flow tables in the OVS switch that are managed by the SDN controller.

- Flow table 0: a classification table.
- Flow table 1: a GTP encapsulation table.
- Flow table 2: a forwarding table.

The SDN controller executes a *forwarding application* to manage normal packet forwarding, and a *diverting application* to manage diverted traffic to a replicated S/P-GW.

The forwarding application applies the following flow rules: the low-priority flow rule in table 0 matches any packet and its action is sending the packet to table 2. Table 2 is a regular forwarding table with a low-priority flow rule that sends any packet to the controller. Besides, other medium-priority flow rules in table 2 match source and destination MAC addresses with an action to forward packets to the proper port. The SDN controller installs these medium-priority flow rules in the switches as classical reactive learning switch applications: whenever the controller receives a packet, the source MAC address is learned and associated to the corresponding switch input port. Then, if the port associated to the destination MAC address is known, a medium-priority flow rule is installed in table 2 of the switch, so that the switch directly forwards the remaining packets of the flow at line rate. Otherwise, the packet is flooded and no flow rule is installed in the switch yet.

On the other hand, when traffic is diverted, for example for moving UE1, which is connected to eNodeB ENB, from the original S/P-GW S/P-GW1 to the replicated one S/P-GW2, the diverting application installs the following flow rules in the GTP-enabled OVS switch that is closer to the eNodeB:

1. a medium-priority flow rule in table 0 that will identify the GTP-U packets originated at the OVS switch (that is, encapsulated by this OVS switch). It will then change the source IP address to that of the ENB and send the packet to table 2, to be forwarded as a normal packet.
2. a high-priority flow rule in table 0 that will identify the packets decapsulated by the OVS switch (i.e. those received at the GTP virtual port of the switch) and send them to table 1, so that these packets will be adequately re-encapsulated to their destination S/P-GW.
3. a low-priority flow rule in table 1 that will match any packet and send it to the input port it has been received at, that is, to the GTP virtual port, for that packet to be encapsulated. This flow rule sets the tunnel destination IP to the S/P-GW1 address. This way, the packets that do not have to be diverted are encapsulated with a GTP-U leading to the original S/P-GW, with the same GTP Tunnel Endpoint Identifier (TEID) as the original packet.
4. a high-priority flow rule in table 1 that will match the packets sent by UE1 and send them to the input port they have been received at, that is, to the GTP virtual port, for them to be encapsulated. This flow rule sets the tunnel destination IP to the S/P-GW2 address. This way, the packets of UE1 are encapsulated with a GTP-U header leading to the replicated S/P-GW, with the same GTP TEID as the original packet.
5. Finally, a medium-priority flow rule in table 0 that will identify the GTP-U packets originated at ENB for S/P-GW1. It will then change the destination IP and MAC addresses to those of the OVS switch, and send the packets to their LOCAL port, for them to be decapsulated. The network stack of the OVS switch will then receive the GTP-U packets and its GTP kernel module will decapsulate them. The GTP virtual port of the OVS switch will then receive the decapsulated packets. We modify the MAC and IP addresses of the GTP packets because decapsulation can only take place if the OVS switch is their final destination.

Tables 1 and 2 summarize the flow rules installed in flow tables 0 and 1 of the OVS switch, respectively, after diverting the traffic of UE UE1. Note that table 2 is a forwarding table that is completely managed by the forwarding application, which is not affected by the diverting application.

Table 1: Flow rules installed in table 0.

Priority	Match	Action
HIGH	IN_PORT=GTP	GOTO_TABLE(1)
MEDIUM	IPv4, NW_SRC=ENB_IP, SET_IP_DST=OVS_IP, NW_DST=S/P-GW1_IP, SET_ETH_DST=OVS_ETH, UDP, TP_DST=2152	OUTPUT=LOCAL
MEDIUM	IPv4, NW_SRC=OVS_IP, SET_IP_SRC=ENB_IP, UDP, TP_DST=2152	GOTO_TABLE(2)
LOW	ANY	GOTO_TABLE(2)

Table 2: Flow rules installed in table 1.

Priority	Match	Action
HIGH	IPv4, NW_SRC=UE1_IP, SET_TUN_DST=S/P-GW2_IP, IN_PORT	SET_TUN_DST=S/P-GW2_IP, IN_PORT
LOW	ANY	SET_TUN_DST=S/P-GW1_IP, IN_PORT

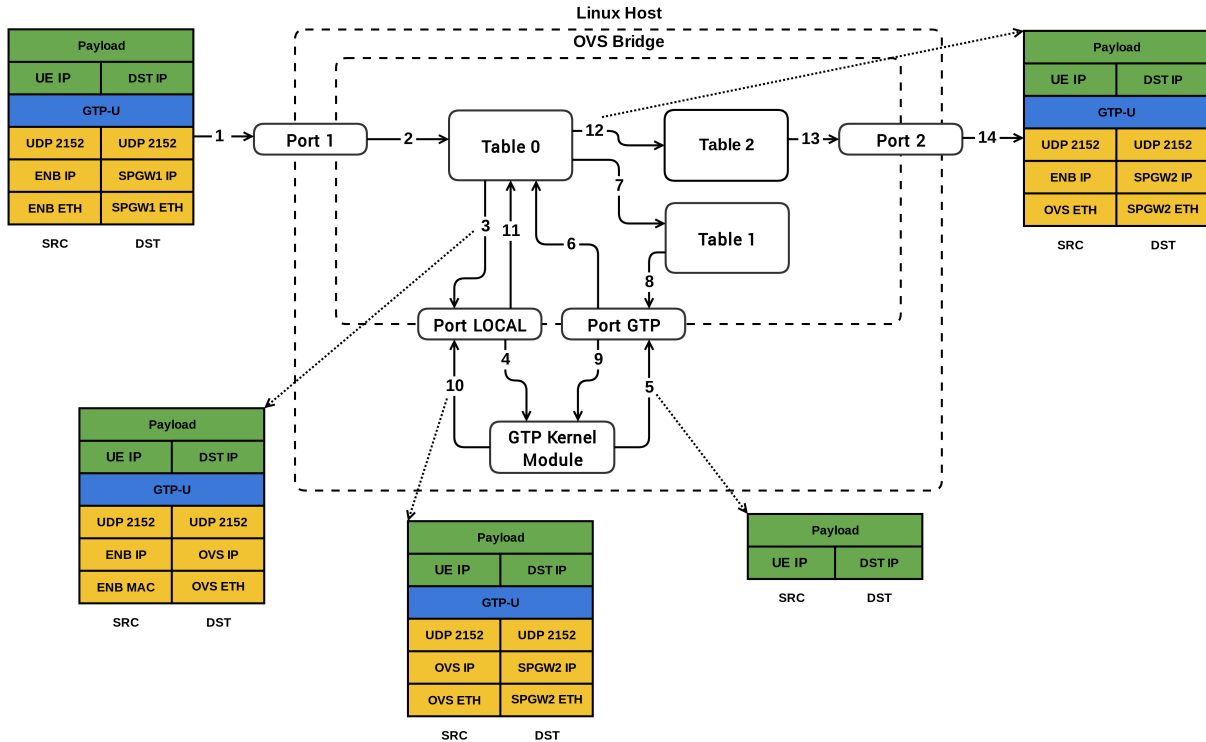

Figure 3: Packet processing inside the GTP-enabled OVS.

The block diagram in Figure 3 shows the processing of a user plane packet in a GTP-enabled OVS that is close to the eNodeB. The following steps are depicted in the diagram:

1. The GTP-U packet is received at the physical port of the device (Port 1 in the figure).
2. The device checks for matches with flows in table 0.
3. The packet matches a flow in table 0 that sets the destination IP and MAC addresses to those of the OVS and the output for the packet to the LOCAL port.
4. The packet is now in the networking stack of the host, which forwards the packet to the GTP kernel module.
5. The GTP kernel module decapsulates the packet, and then it forwards the inner packet to the bridge through the GTP port.
6. The packet checks for matches with the flows in table 0.
7. The packet matches a flow in table 0 that forwards the packet to table 1.
8. The packet matches a flow in table 1 that sets the tunnel destination IP to the desired S/P-GW and the output for the packet to the GTP port.
9. The packet is forwarded from the GTP port to the GTP kernel module.
10. The packet is now encapsulated with the desired S/P-GW as the destination GTP endpoint, with the same TEID as the original tunnel, and then inserted into the bridge through the LOCAL port.
11. The packet checks for matches with the flows in table 0.
12. The packet matches a flow in table 0 that sets the source IP and MAC addresses to those of the ENB and forwards the packet to table 2.
13. The packet matches a flow in table 2 that takes the packet to the proper physical port.
14. The GTP-U packet is forwarded through the physical port of the device (Port 2 in the figure).

4.3 Characteristics of the Solution

We have implemented a fully operative solution with the following characteristics:

- The location of the traffic exit and entry points for the UE can be modified dynamically, thanks to the dynamic replication of a fully operational stateful 3GPP-compliant S/P-GW by replicating the GTP-C messages that the MME sends to the original S/P-GW through the S11 interface.
- User plane traffic can be diverted with existing technology to another S/P-GW at the network edge. No OpenFlow GTP extensions are necessary. An existing Open vSwitch patch can be used to encapsulate and decapsulate GTP packets transparently to OpenFlow.

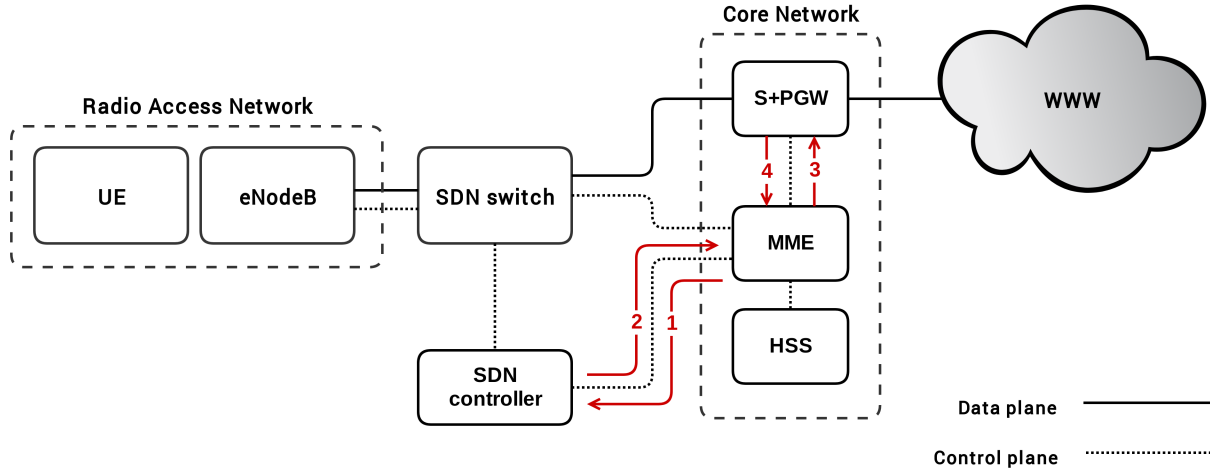

Figure 4: Path for GTP-C messages from MME to S/P-GW.

- The process of replicating a 3GPP-compliant S/P-GW and dynamically diverting per-user traffic to it is completely transparent to the network, without any modification of current entities, leveraging SDN flexibility. As a result, our solution can be quickly deployed on any existent 4G network and is completely interoperable with existing entities.

Therefore, our solution is fully 3GPP compliant and can be deployed on a real network without any changes in the OpenFlow protocol nor in the SDN controller. It only requires patching an OVS device to extend OVS tunnel virtual ports in order to support the GTP-U protocol.

5 Analysis of the Solution

As shown in the previous sections, our proposal can be easily integrated in existing 4G networks or included in new 5G deployments to provide a operative MEC architecture that can even handle application session continuity after handovers or MEC application relocations. In this section we analyze the performance of the solution to demonstrate that it does not affect the operation of the network. We analyze separately its control and data planes, since they are independent.

5.1 Initial Considerations

The control plane handles the replication of the default S/P-GW context into the new S/P-GWs. Our solution implies that the GTP-C packets sent by the MME are forwarded through the SDN controller and that the SDN controller must store these packets. Then the stored GTP-C packets are sent to the new S/P-GW. Fig. 4 depicts the path of the GTP-C packets from the MME to the S/P-GW through the SDN controller. In this section we study the impact of this approach in depth.

First, we must consider the impact of MME GTP-C packet forwarding through the SDN controller. This increases the amount of control traffic in the OpenFlow channel between the SDN controller and the MME OVS switch.

GTP-C packet forwarding clearly introduces some *control communications overhead between the MME and the S/P-GW*. Passing through the SDN controller may delay these packets. The total latency of a control GTP-C packet that the MME sends to the S/P-GW will increase with respect to a normal packet transmission. This extra latency will be given by the contributions of packet transmission delay from the OVS switch to the controller; the processing delay of the GTP-C packet at the controller; and the transmission delay from the controller to the OVS switch. The only processing at the controller is obtaining the destination IP address of the packet (i.e. the S/P-GW address), and storing the packet in the list of messages associated to that S/P-GW, whose elapsed time is negligible, in the order of microseconds. The time to send the packet to the controller is the transmission delay of an OpenFlow `PACKET_IN` message containing the GTP-C packet. Analogously, the time to transfer the packet from the controller to the OVS device is the transmission delay of an OpenFlow `PACKET_OUT` message containing the GTP-C packet. The total measured latency for the communication is in the order of 10 milliseconds, which is coherent with previous studies on the latency of the control plane of SDN-enabled switches [32].

Even though this may look acceptable, we studied how to reduce this delay: Instead of sending each GTP-C packet to the SDN controller, storing it and then sending the GTP-C packet back to the switch for normal forwarding to the S/P-GW, we also considered the possibility of sending the packet to the controller and forwarding it directly to the S/P-GW (e.g. using two output actions inside one flow rule, or an OpenFlow `ALL Group Action` that outputs to the proper port of the device and to the SDN controller). This way, we can totally avoid the SDN controller overhead in GTP-C communications and store packets in the SDN controller asynchronously.

The next relevant metric is the *amount of information that must be stored in the system*. In our message replication proposal, the SDN controller is the most affected entity by state replication, since it must store the GTP-C messages that the MMEs send to the S/P-GWs.

In principle we considered that the SDN controller stored all GTP-C packets from each MME up to that moment. This simplest approach is valid for a proof-of-concept, but it clearly does not scale well. From some moment on, some GTP-C packets stored at the SDN controller should be dropped or transferred to another storage system. However, dropping these packets would affect the context of future S/P-GWs deployments. For example, it would not be possible to completely establish the GTP-U tunnel of a user in a new S/P-GW, and therefore we would not be able to move that user to a newly deployed S/P-GW.

To avoid this drawback we propose the following modifications beyond the simplest version:

- Only storing messages associated to active MMEs. That is, when a MME gets disconnected, all received messages from that MME are removed.
- Only storing messages associated to active S/P-GWs. That is, when a S/P-GW gets disconnected, all received messages that are related to that S/P-GW are removed.

By doing so, our solution does not lose any context information and we reduce the amount of stored information in the SDN controller. We remark that GTP-C packet size is relatively small. For example, two basic GTP-C messages that must be stored for each UE are *Create Session Request* and *Modify Bearer Request*, which the MME sends when the users get connected to the network. Their sizes are less than 150 and 50 bytes, respectively.

Another metric that we consider for the control plane is the *time for state replication*. After launching the VM with the S/P-GW, the SDN controller will send all the stored GTP-C messages that are associated to the original S/P-GW. The time to send these packets is the time it takes

the SDN controller to send them using `PACKET_OUT` OpenFlow messages. After the first packet is transmitted, the rest are transmitted sequentially. The S/P-GW must have finished processing the previous message when it receives a new one. In the OpenAir-CN implementation, this processing takes less than 10 milliseconds for *Create Session Request* messages and about 1 millisecond for *Modify Bearer Request* messages.

We remark that moving a user flow does not affect the data plane traffic at all, since data plane traffic will be forwarded through the original S/P-GW while the replicated S/P-GW is not ready. Hence, the initial control plane delay that we have described should be understood as the elapsed time since traffic diversion is triggered until it is operational.

Finally, the *control information overhead in the network*, is the amount of control information that must be transmitted through the network during the state replication process. As we have previously described, our solution must send all the packets between the MME and the S/P-GW that were previously stored. This is less than 200 bytes per each user that is connected to the S/P-GW.

Despite the described improvements, the replication scheme in this section still requires storing the GTP-C messages that are received at the original S/P-GW in the SDN controller and transmitting them to the new S/P-GW. For this reason we refer to it as *naive message replication*. In the following section we present further improvement that increase the scalability of our solution.

5.2 Selective Message Replication

The first additional improvement we propose is to only store messages associated to active UEs. That is, when a UE gets disconnected, all messages received regarding that UE are removed. In other words, the amount of information that needs to be stored is proportional to the number of active UEs. However, the transmission delay of all stored GTP-C packets may still be unacceptable for an extremely dynamic scenario with many users connected to an S/P-GW. To mitigate this, we introduce another improvement: we only send the GTP-C packets that are associated to the UEs we want to move. If later on we need to move any other UEs, it would suffice to send the GTP-C packets of those new UEs. Therefore, both the information overhead of the migration process and the state replication delay are independent from the amount of stored GTP-C messages. Indeed, they are proportional to the number of users to be migrated.

We refer to the strategy that results from applying these two additional improvements to the naive message replication as *selective message replication*. This strategy scales much better. However, it requires some modifications in the implementation of our proposal:

1. For each UE, after sending the *Create Session Request*, the SDN controller must extract from the *Create Session Response* the S/P-GW GTP TEIDs corresponding to the S11 and S1U interfaces as well as the IP address assigned to the replicated UE. This information must also be stored in the SDN controller. Then, when the SDN controller replicates the state of the original S/P-GW for a user in a new S/P-GW instance, the SDN controller needs to modify the S11 GTP-C TEID used in the *Modify Bearer Request* message for the new S/P-GW in order for the latter to accept the message. The overhead due to this header modification is almost negligible.
2. Two additional modifications must be applied to the data plane traffic that is forwarded to the replicated S/P-GW, for the latter to be operational. First, the S1U GTP-U TEID in

the packets from the eNodeB to the S/P-GW (uplink direction) must be modified with the value stored in the SDN controller. Second, the original network address of the UE must be translated to the address that the replicated S/P-GW assigns to the UE in the uplink traffic and vice versa in the downlink.

The first modification can be easily implemented in the SDN controller. It just requires a simple header change in control plane traffic. We can extend our data plane solution in a similar way to support the other two modifications, which involve header changes in data plane traffic, at line rate. We can leverage the GTP-enabled OVS device, which we have already introduced, to decapsulate the packets, perform the network address translations and encapsulate them again by setting the proper TEID.

Note that these modifications need some information to be stored in the SDN controller. In addition to the GTP-C packets associated to each active UE, the SDN controller must store, for the UEs that migrate to the replicated S/P-GW, the S11 and S1U GTP TEIDs and the new IP address assigned by that S/P-GW. However, note that this information is proportional to the number of migrated UEs, which will obviously be less than the active UEs.

5.3 Comparison with Alternative Solutions

One of the main contributions of this paper, is a fully distributed technique based on SDN to seamlessly maintain the connections even when endpoint of the GTP tunnel (the S/P-GW) is a new instance. That is, we use SDN to replicate the state of an old instance of an S/P-GW into a new one. Therefore, it is specially relevant to analyze the performance of this technique, and to compare it with some alternative schemes found in the literature to replicate the state of an application or a network function.

In this comparison we consider the naive and selective message replication solutions versus stateless S/P-GWs [20, 21], RAM replication [23] and a custom protocol [22]:

- Naive message replication: Replication of all received GTP-C messages in the original S/P-GW into the new S/P-GW.
- Selective message replication: Replication of the GTP-C messages of the UEs to be moved into the new S/P-GW.
- RAM replication: RAM dump of the original S/P-GW into the new one.
- Stateless S/P-GWs with centralized state: Stateless S/P-GW entities whose states are centralized in a database.
- Custom protocol to replicate the state of the S/P-GW.

First, we compared the schemes qualitatively by checking if they:

- required to modify any of the EPC entities.
- allowed for selective replication.
- implied service downtime.

Table 3: Qualitative comparison of control plane replication approaches.

Approach	References	Modification of EPC entities?	Selective replication?	Downtime?	Overhead in control plane?
Naive message replication	Our proposal	No	No	No	No
Selective message replication	Our proposal	No	Yes	No	No
RAM replication	[23]	No	No	Yes	No
Stateless S/P-GWs	[20, 21]	Yes	Yes	No	Yes
Custom protocol	[22]	Yes	Yes	No	No

- introduced control plane overhead.

The approach combining stateless S/P-GW modules and a centralized state requires modifying the S/P-GW modules and storing their state in a centralized database. The latter introduces overhead in control plane communications. However, it allows for selective replication without service downtime. The RAM replication strategy does not require any modification of current EPC entities but, since it replicates the whole RAM of a VM, it does not allow for partial state replications. Also, as described in [23], this approach needs to stop the service before dumping the RAM, and thus it incurs in downtime. Finally, a custom protocol for state replication optimized for moving individual user flows to the edge would require modifying the S/P-GW to support the regeneration of specific GTP tunnels, to allow for selective replication without any downtime.

Our message replication proposals do not require any modification of S/P-GW entities and there is no downtime because the original S/P-GW entity does not participate in the replication (i.e. it continues operating uninterruptedly during the replication process). Besides, the overhead in control plane communications can be mitigated by sending the packets asynchronously to the SDN controller, as we have previously explained. The naive strategy involves complete state replication, but the selective version allows for a fine-grained replication.

Table 3 summarizes the qualitative comparison.

The solutions that need to modify EPC entities are not interoperable with existing deployments. Since interoperability is a basic requirement for us, we only carried out a quantitative benchmarking of the three interoperable alternatives. In it we evaluated the main metrics involved in state replication: a) amount of information that must be stored in the system, b) time needed for state replication and c) network overhead. Moreover, we studied the scalability of these alternatives, by analyzing their performance as the number of registered and moved users grew.

The testbed for these experiments consisted of four VMs (1 vCPU, 2 GB RAM, 10 GB Disk) in an OpenStack cloud, interconnected through a 1 Gbit/s network. These VMs ran an ONOS SDN controller, one MME and two S/P-GWs from OpenAir-CN, respectively. The results average 10 independent executions.

Fig. 5 shows the amount of information that must be stored in the system as the number of UEs increases. The first we observe is that the RAM approach does not require storing any information in the system, since when the replication is triggered the current RAM of the default S/P-GW is dumped and transferred to the new one. On the other hand, the information stored in the message replication proposals grows linearly with the number of users. Particularly, the naive approach requires 189 bytes per each registered UE, whereas the selective approach requires 16 bytes per each moved user plus 189 bytes per registered user. The former correspond to the S11 & S1U GTP TEIDs and the IP address of the UE in the new S/P-GW, and the latter to two GTP-C messages.

Fig. 6 represents the network overhead (amount of control information transmitted) during a complete state replication. We can see that it is considerably larger for the RAM dump, ranging from 160 MB for a single user to 2 GB for 1,000 registered users. Moreover, with this strategy the

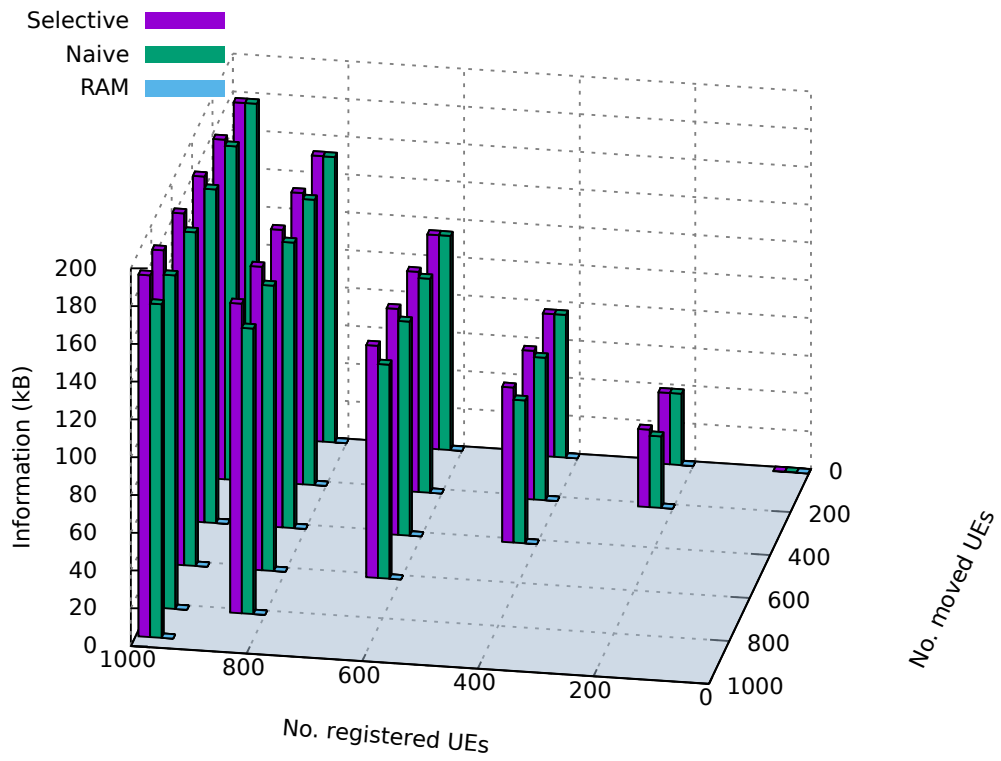

Figure 5: Amount of information stored in the system.

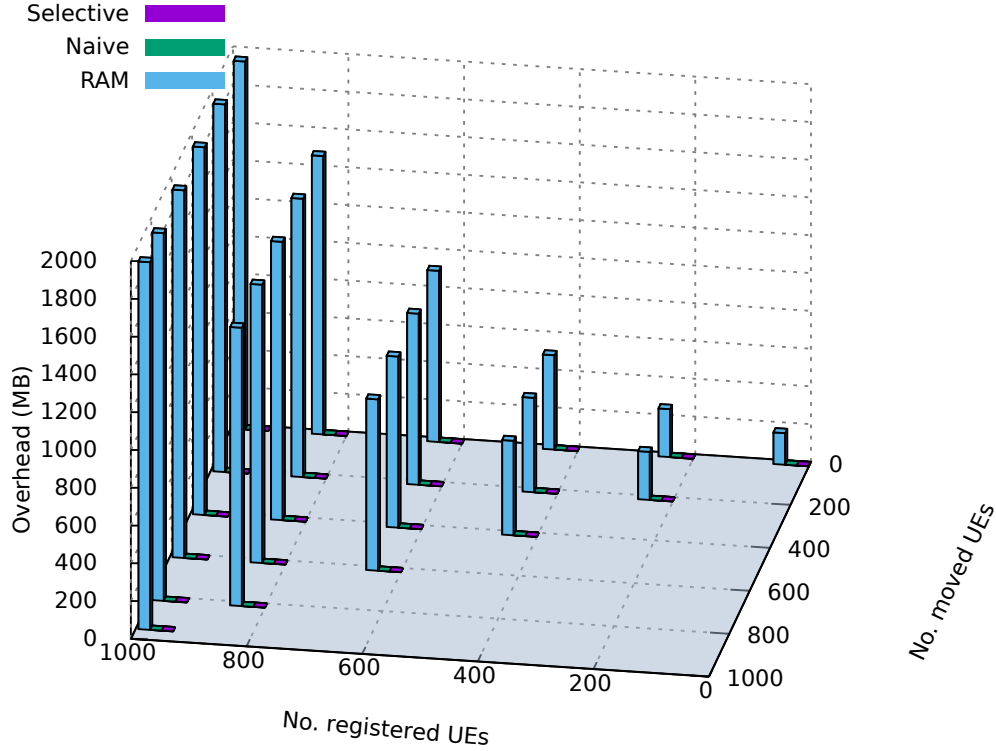

Figure 6: Overhead introduced in the network.

amount of information stored does not depend on the number of moved users but on the number of registered ones. Note that the overhead does not increase linearly with the number of registered users, but quadratically. Conversely, message replication approaches introduce a minimum overhead, introducing just 189 bytes per registered user in the naive version and 189 bytes per moved one in the selective version. For 1,000 registered and moved users, it is three orders of magnitude less than for the RAM replication. This highlights the potential of our message replication strategies, specially of the selective version, due to their minimum impact in the network.

Fig. 7 represents the elapsed time for a complete state replication. The time needed with the RAM replication strategy is much longer than with our proposals, for any number of registered or moved UEs. Again, RAM replication does not allow for a selective replication in case of moving less than all registered UEs. The difference is specially relevant when replicating the state for just a single registered user: it takes less than 50 milliseconds with message replication approaches and over 26 seconds with the RAM replication strategy. A breakdown of the times involved in the RAM replication approach yields the following results: about 16.5 seconds to dump the RAM to disk, about 1 second to transfer 160 MB of dumped RAM to the replicated S/P-GW and about 8.5 seconds to restore the RAM from disk. We have also observed that the processes of dumping and restoring the RAM do not depend on the amount of used RAM, but on the total RAM of the

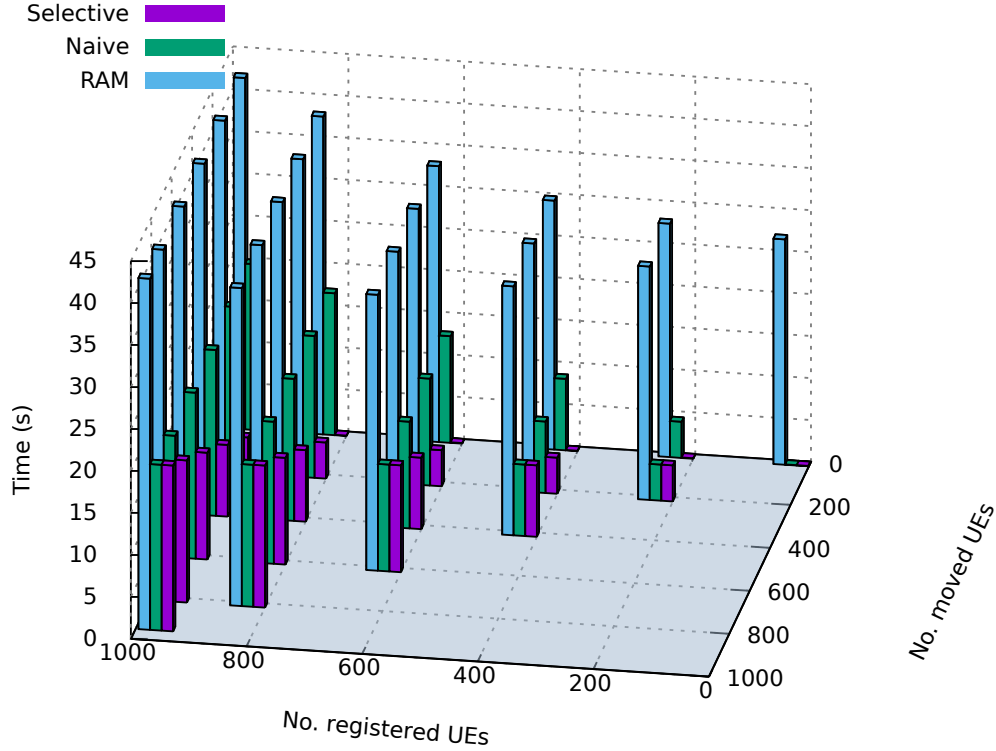

Figure 7: Elapsed time for state replication.

VM. The time needed for transferring the dumped RAM increases quadratically with the number of registered users, because it depends on the amount of transmitted information (as studied in Fig. 6). Conversely, the elapsed time of naive message replication grows linearly with the number of registered users whereas the selective version does so with just the number of moved users, allowing for a faster replication. A breakdown of the time of these approaches shows that the time needed to transmit a message is less than 1 millisecond and the S/P-GW takes between 1 and 10 milliseconds to process a received message and create the proper context.

5.4 Data Plane Analysis

Regarding the data plane, our solution requires an OVS switch patched with GTP-U capabilities, which should be close to an eNodeB. The main impact is the processing load in that switch to decapsulate a packet and re-encapsulate it again. Nevertheless, this is only performed in the uplink. Downlink packets are forwarded as normal traffic.

We analyzed experimentally the overhead in data plane performance. The metrics that we studied were TCP throughput and packet delay. We took as baseline the scenario *without GTP processing*, in which GTP-U traffic is forwarded normally (i.e. without applying our solution). This

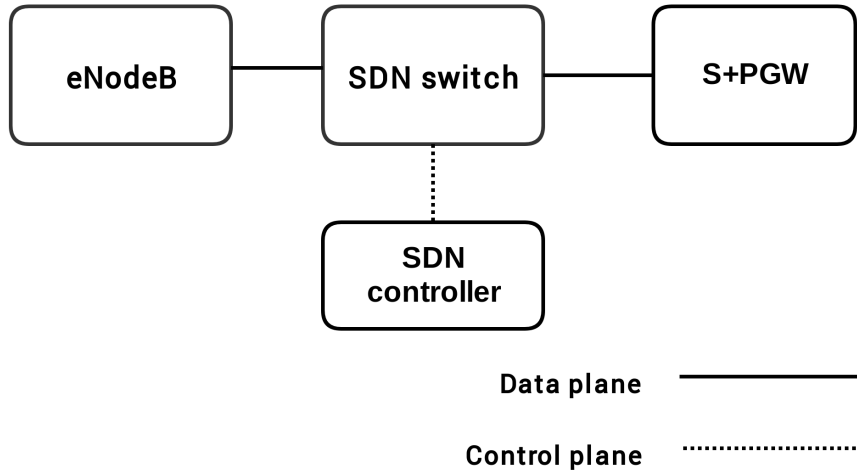

Figure 8: Testbed for analyzing the data plane overhead.

scenario determines the best possible performance. We compared it with an scenario *with GTP processing*, whose performance is necessarily lower.

The testbed in this experiment recreated a realistic setup with VirtualBox VMs (1 CPU and 2 GB RAM). Four VMs represented the eNodeB, the S/P-GW, the OVS switch and the ONOS SDN controller. The eNodeB, the S/P-GW and the SDN controller had network interfaces that were connected to the OVS switch VM through different internal networks. This way, the traffic between the eNodeB and the S/P-GW had to traverse the OVS switch. Fig. 8 depicts the architecture of the testbed. We created a GTP tunnel between the eNodeB and the S/P-GW for the traffic to be GTP-encapsulated when traversing the OVS switch. Since GTP is a raw IP encapsulation protocol we added static ARP entries in the eNodeB and the S/P-GW to enable connectivity between the GTP interfaces that were created at both endpoints.

The first experiment studied communication latency between the eNodeB and the S/P-GW. Fig. 9 shows boxplots of the round-trip time (RTT) of ICMP packets generated with the ping tool. The whiskers correspond to the 99th percentile and outliers have been omitted for clarity. Fig. 10 shows the histogram of the RTT of those packets. We can see that the distribution of the delay in both scenarios was similar and approximately normal. The only difference is that the median is about 1.6 ms without GTP processing and 1.7 ms with it. This indicates that the RTT overhead of our solution is about 0.1 ms. The first conclusion from this result is a lower bound on achievable latency with our solution of 0.1 ms.

The next experiment studied the maximum TCP throughput achieved with our data plane solution. We used the `iperf3` tool to generate an intended traffic rate between the eNodeB and the S/P-GW and measured how much of this rate was achievable. We also analyzed CPU usage of the OVS switch VM to study its relationship with the overhead of our solution. Fig. 11 shows TCP downlink throughput and CPU usage for intended throughputs between 0 and 1400 Mbit/s. As we can see, target throughputs up to 1000 Mbit/s were reached. From that point on, throughput got saturated at about 1050 Mbit/s for the scenario without GTP processing and at a slightly lower rate for the scenario with GTP processing. This slight difference in the downlink was also reflected

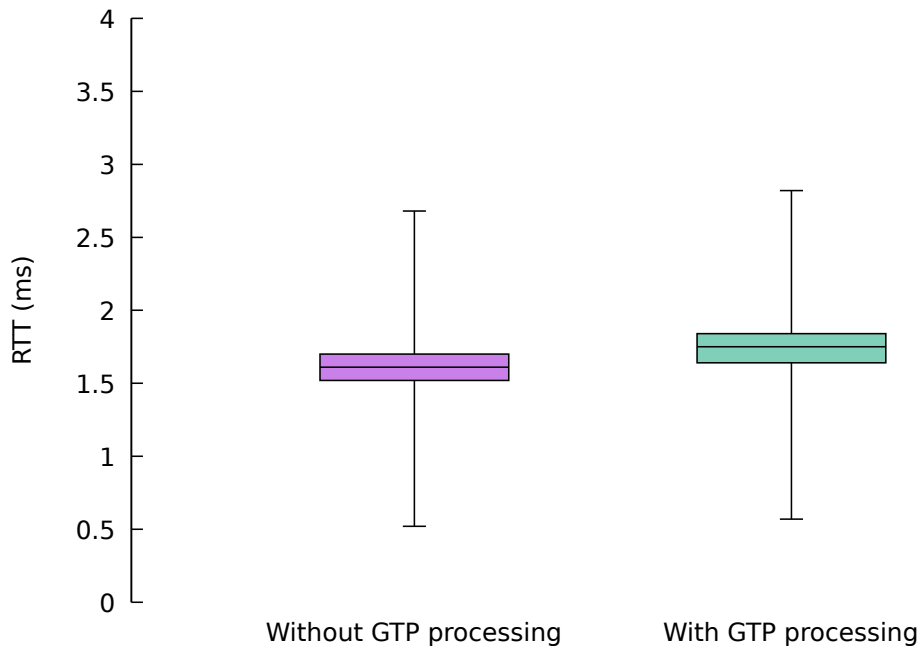

Figure 9: Boxplot of packet delay in the VirtualBox testbed.

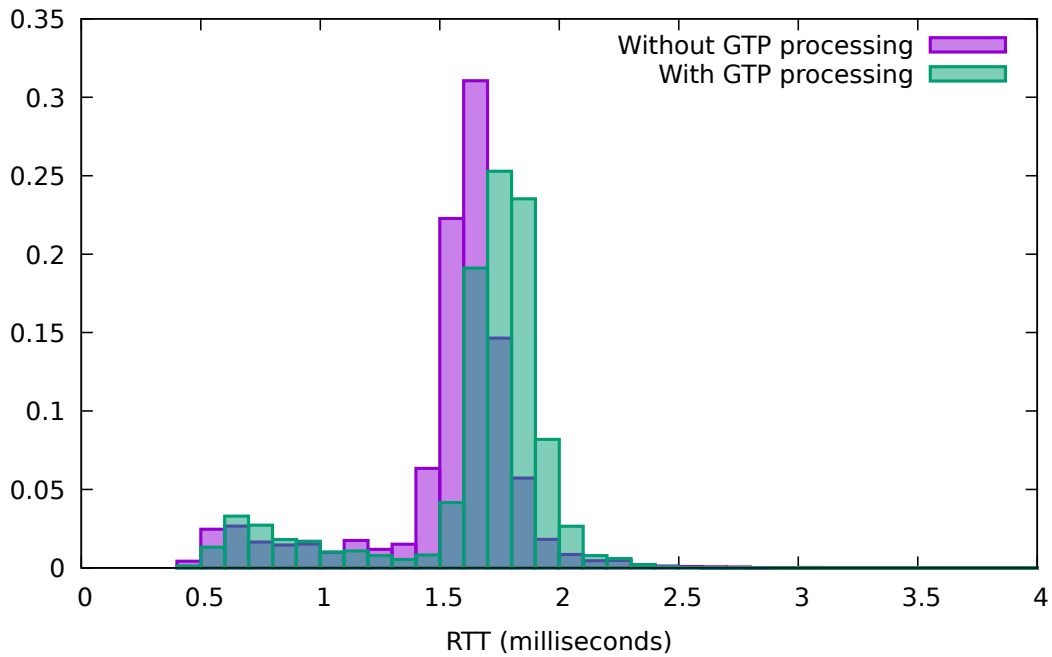

Figure 10: Histogram of packet delay in the VirtualBox testbed.

in CPU usage: for the same target throughput, the scenario with GTP processing took up to 10% more CPU.

Even though the impact of our solution in downlink throughput was relatively low, we could appreciate an increase of CPU consumption of the OVS switch. To further understand the relationship between consumed CPU and achieved throughput, we calculated a linear fit regression between both metrics for each execution. Fig. 12 depicts the results. The correlation between the parameters was about 0.98 in both scenarios, confirming a strong linear relationship between the metrics. The slope was practically the same, except for slight differences due to the TCP ACKs in the uplink, but the offset was noticeably higher in the scenario without GTP processing (about 37 Mbit/s). That is, for a given level of consumed CPU, the scenario without GTP processing achieved about 37 Mbit/s extra throughput. The offset corresponded to the processing mechanism and did not depend on traffic rate.

Fig. 13 shows achieved TCP uplink throughput and CPU usage for intended throughputs between 0 and 1400 Mbit/s. The intended throughput was achievable up to 1050 Mbit/s in the baseline scenario, whereas with GTP processing it got saturated at 700 Mbit/s. This different behavior was again also observed in CPU usage, which grew rapidly with GTP processing to 100% at about 700 Mbit/s. Unlike in the downlink, GTP processing had noticeable impact on maximum achievable throughput in the uplink. Nevertheless, we remark that this is only due to the CPU processing in the OVS switch, which in our experiments was implemented in a VirtualBox VM. Therefore, in a real deployment with a physical SDN switch or a specialized computer, the behavior would be similar at much higher rates.

We analyzed again the relationship between CPU usage and maximum achievable throughput by means of linear fit regressions between both metrics for each execution. Fig. 14 depicts the results. In this case there is also a strong linear relationship between both metrics, with correlations above 0.99 in both scenarios. The linear fit without GTP processing was similar to that of the downlink, as expected. Again, the fixed difference due the GTP processing mechanism was about 37 Mbit/s, but now the slopes were clearly different. A 1% increase in CPU yielded a 10.88 Mbit/s increase in achievable throughput in the baseline scenario, whereas there was only a 6.98 Mbit/s increase with GTP processing. We can interpret these results as that GTP processing in the OVS switch requires an increase in CPU usage that affects mainly the uplink. This CPU overhead has a linear relationship with traffic rate, so that just $\frac{6.98}{10.88} \times 100 = 64\%$ of the target throughput is achievable for a given CPU usage. We remark that this overhead is needed for flow-specific traffic diversion, which requires packet decapsulation and reencapsulation.

6 Conclusions

Edge computing is one of the key technologies for 5G, bringing applications closer to the user to ensure low-latency responses, avoid transmitting large data stream volumes through the network or eliminate potential bottlenecks in the core of the network. Although this concept was not considered during the design of 4G networks, it can be integrated into them to attain the same benefits.

In this paper we have presented a proposal that simplifies the integration of MEC applications. It allows deploying a new S/P-GW in the edge for particular users and diverting their traffic to that endpoint. This way, an orchestrator can launch a MEC application at the edge and redirect user traffic to that application using SDN. Furthermore, with our system the application could be already running in another location (e.g. the cloud, the core of the network, other edge location),

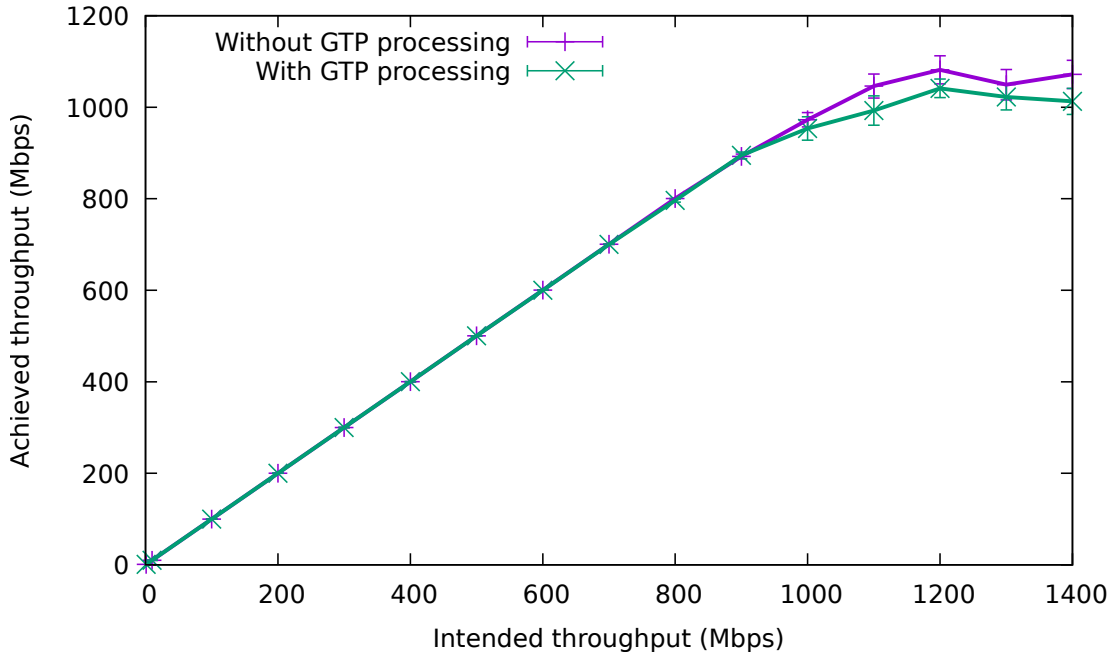

(a) Achieved throughput

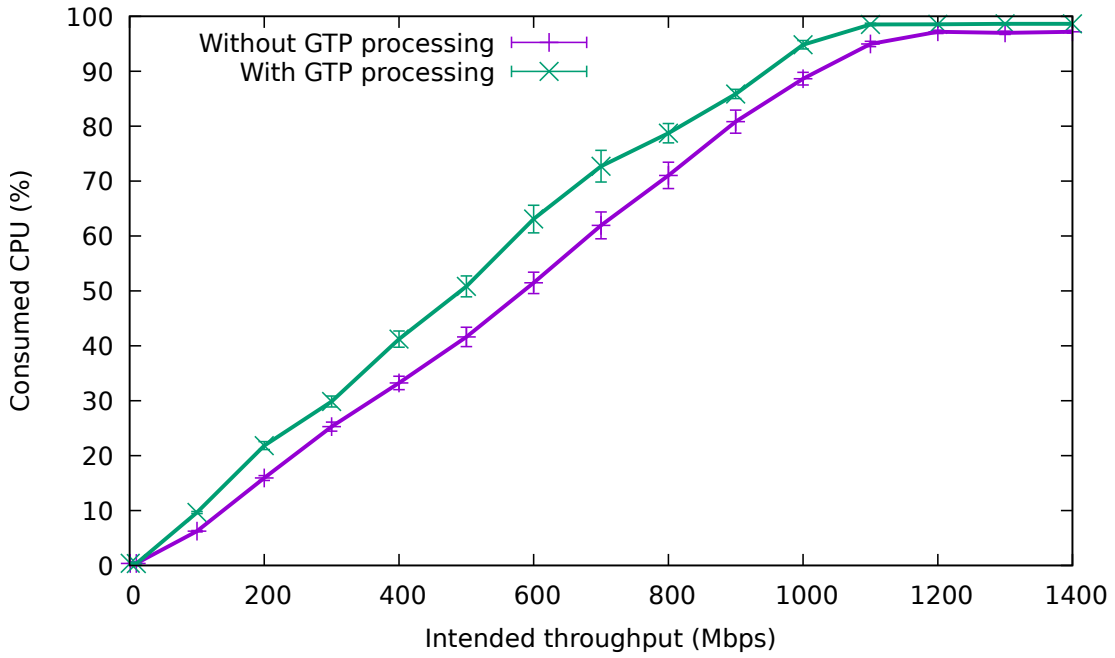

(b) CPU usage

Figure 11: TCP downlink throughput: Achieved throughput and CPU usage for different target throughputs.

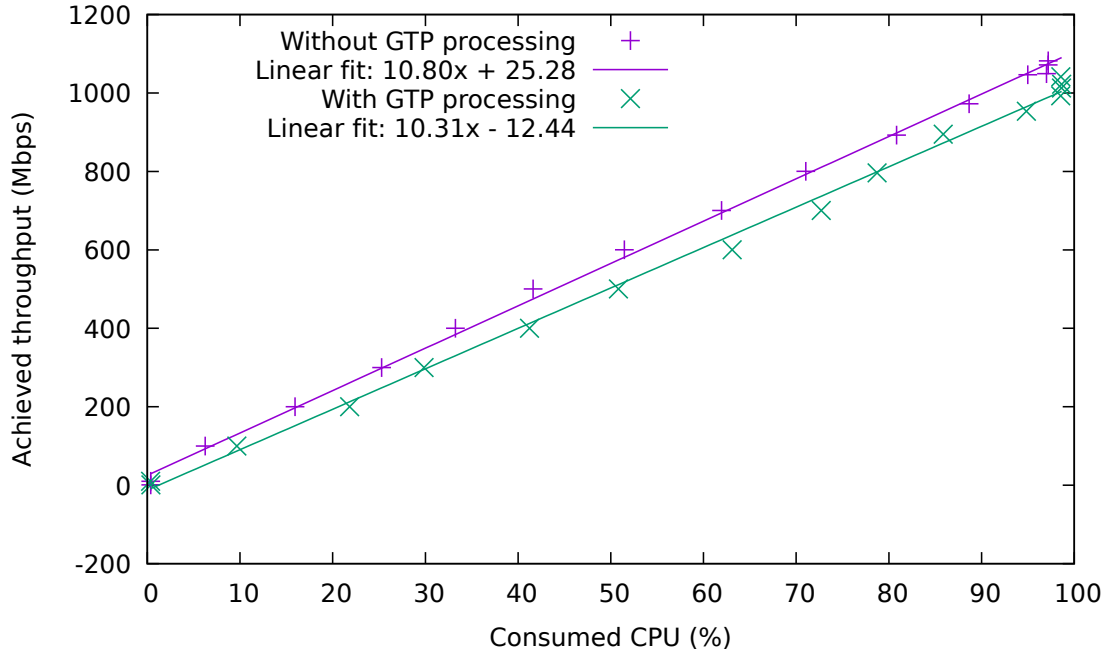

Figure 12: TCP downlink throughput: Relationship between achieved throughput and CPU usage.

and be relocated to the new MEC host.

In 4G networks our solution is directly applicable to S/P-GW replication. In 5G networks the UPF, which includes the S-GW and the P-GW, anchors the IP address for a UE the same way a P-GW does in 4G, and it can include the “UL CL” (Uplink classifier) functionality to divert some traffic by matching traffic filters. In that scenario there are multiple session anchors that can be used to direct the traffic from the UE to different locations (DN or Data Networks). Then, our solution can be also viewed as a practical implementation of the UL CL functionality that uses SDN to facilitate advanced features such as the dynamic deployment of new session anchors and the relocation of applications.

SDN is the key technology for our proposal. It is used to redirect the desired traffic from a UE to the new endpoint (probably located at the network edge in the cases when we want to reduce the latency). To avoid disrupting existing connections the new S/P-GW must maintain the context of the previous instance, so we have used SDN in a novel way to replicate its state. We capture the control messages that are sent to the S/P-GW and resend them when we want to replicate the context in the new instance. We have analyzed the performance of this fully distributed approach and compared it with other possible alternatives to replicate the state. Our solution is highly competitive both quantitatively and qualitatively.

Acknowledgements

This work has been supported by “la Caixa” Foundation (ID 100010434) fellowship LCF/BQ/ES18/11670020, MINECO grant TEC2016-76465-C2-2-R, and Xunta de Galicia grant GRC 2018/053, Spain.

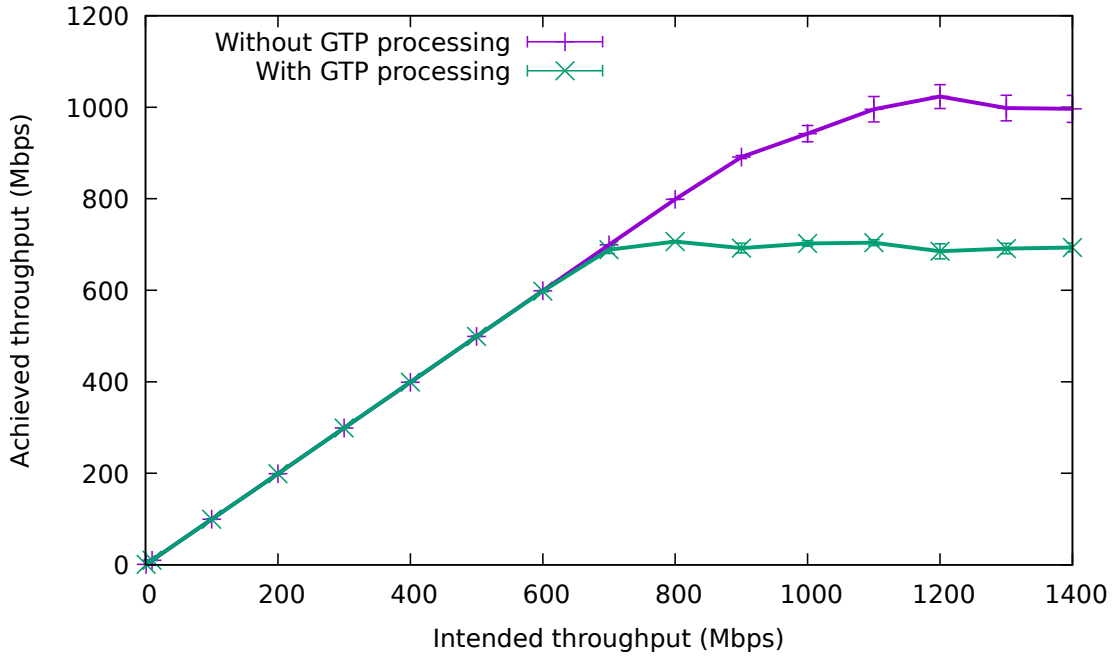

(a) Achieved throughput

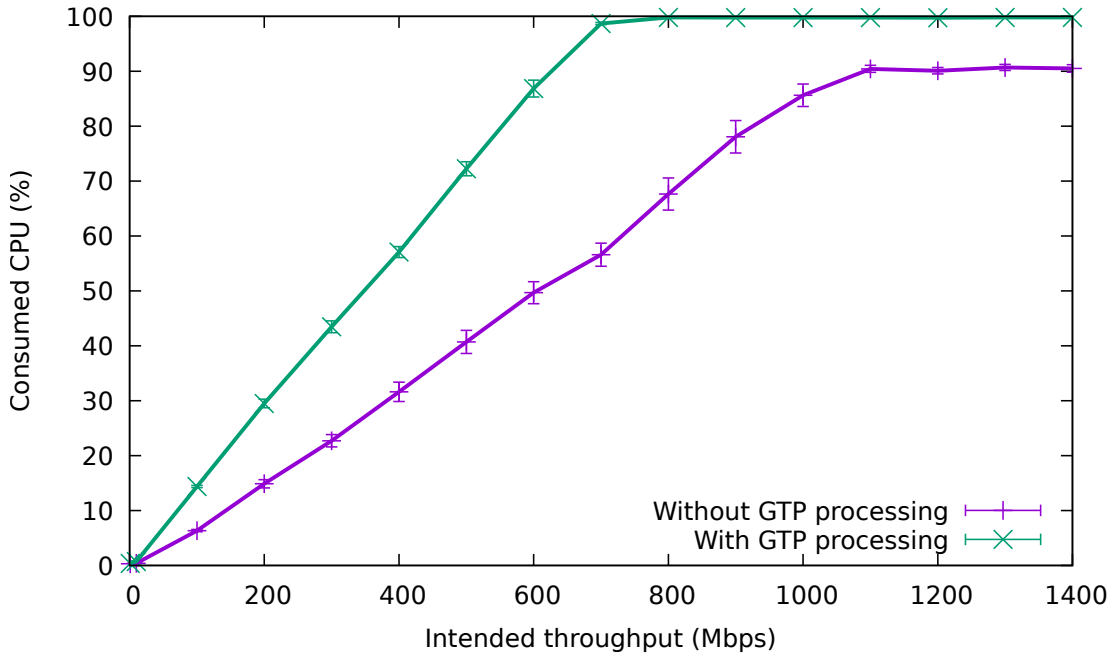

(b) CPU usage

Figure 13: TCP uplink throughput: Achieved throughput and CPU usage for varying target throughput.

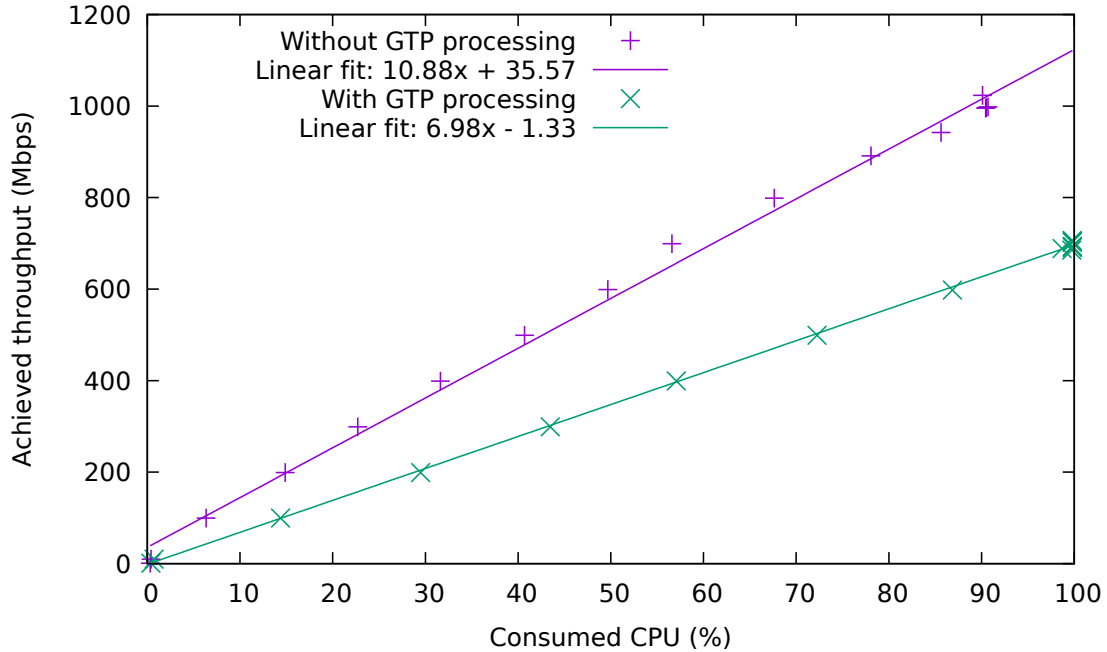

Figure 14: TCP uplink throughput: Relationship between achieved throughput and CPU usage.

References

- [1] Y. C. Hu, M. Patel, D. Sabella, N. Sprecher, and V. Young, “Mobile Edge Computing - A key technology towards 5G,” *ETSI white paper*, vol. 11, no. 11, pp. 1–16, 2015.
- [2] F. Giust, X. Costa-Perez, and A. Reznik, “Multi-Access Edge Computing: An overview of ETSI MEC ISG,” *IEEE 5G Tech Focus*, vol. 1, no. 4, 2017.
- [3] “ETSI GR MEC 017 v1.1.1. Mobile Edge Computing (MEC); Deployment of Mobile Edge Computing in an NFV environment,” February 2018.
- [4] F. Giust, G. Verin, K. Antevski, J. Chou, Y. Fang, W. Featherstone, F. Fontes, D. Frydman, A. Li, A. Manzalini *et al.*, “MEC deployments in 4G and evolution towards 5G,” *ETSI, White Paper No. 24*, February 2018.
- [5] “ETSI GS MEC 002 v2.1.1. Multi-access Edge Computing (MEC); Phase 2: Use Cases and Requirements,” October 2018.
- [6] S. Kekki, W. Featherstone, Y. Fang, P. Kuure, A. Li, A. Ranjan, D. Purkayastha, F. Jiangping, D. Frydman, G. Verin, K.-W. Wen, K. Kim, R. Arora, A. Odgers, L. M. Contreras, and S. Scarpina, “MEC in 5G networks,” *ETSI, White Paper No. 28*, June 2018.
- [7] A. Osseiran, F. Boccardi, V. Braun, K. Kusume, P. Marsch, M. Maternia, O. Queseth, M. Schellmann, H. Schotten, H. Taoka *et al.*, “Scenarios for 5G mobile and wireless com-

- munications: the vision of the METIS project,” *IEEE Communications Magazine*, vol. 52, no. 5, pp. 26–35, 2014.
- [8] 3GPP, “System Architecture for the 5G System; Stage 2 (Release 15),” 3rd Generation Partnership Project (3GPP), Technical Specification (TS) 23.501, 12 2018, version 15.4.0. [Online]. Available: <https://portal.3gpp.org/desktopmodules/Specifications/SpecificationDetails.aspx?specificationId=3144>
- [9] D. Sabella, A. Vaillant, P. Kuure, U. Rauschenbach, and F. Giust, “Mobile-Edge Computing architecture: The role of MEC in the Internet of Things,” *IEEE Consumer Electronics Magazine*, vol. 5, no. 4, pp. 84–91, 2016.
- [10] L. Peterson, A. Al-Shabibi, T. Anshutz, S. Baker, A. Bavier, S. Das, J. Hart, G. Palukar, and W. Snow, “Central office re-architected as a data center,” *IEEE Communications Magazine*, vol. 54, no. 10, pp. 96–101, 2016.
- [11] “M-CORD Open Source Reference Solution for 5G Mobile Wireless Networks.” [Online]. Available: <https://www.opennetworking.org/solutions/m-cord/>
- [12] “SDN enabled virtual EPC gateway (proposal).” [Online]. Available: https://nfvwiki.etsi.org/images/NFVTST%2815%29000006_NFV_ISG_PoC_Proposal_SDN_Enabled_EPC_Gwy_r2_was_PER114.pdf
- [13] “SDN enabled virtual EPC gateway (results).” [Online]. Available: https://nfvwiki.etsi.org/images/PoC_34_report_FINAL.PDF
- [14] M. R. Sama, L. M. Contreras, J. Kaippallimalil, I. Akiyoshi, H. Qian, and H. Ni, “Software-defined control of the virtualized mobile packet core,” *IEEE Communications Magazine*, vol. 53, no. 2, pp. 107–115, 2015.
- [15] J. Heinonen, T. Partti, M. Kallio, K. Lappalainen, H. Flinck, and J. Hillo, “Dynamic tunnel switching for SDN-based cellular core networks,” in *Proceedings of the 4th workshop on All things cellular: operations, applications, & challenges*. ACM, 2014, pp. 27–32.
- [16] V.-G. Nguyen, A. Brunstrom, K.-J. Grinnemo, and J. Taheri, “SDN/NFV-based mobile packet core network architectures: a survey,” *IEEE Communications Surveys & Tutorials*, vol. 19, no. 3, pp. 1567–1602, 2017.
- [17] A. Zabala, E. Rojas, J. M. Roldan, and L. Pulido, “Towards per-user flexible management in 5G,” *arXiv preprint arXiv:1801.08191*, 2018.
- [18] “GTP-U tunnel support: OvS kernel module extension.” [Online]. Available: https://github.com/pa5h1nh0/GTP-U_OvS-kernel-extension
- [19] M. Simsek, A. Aijaz, M. Dohler, J. Sachs, and G. Fettweis, “The 5G-enabled tactile internet: Applications, requirements, and architecture,” in *Wireless Communications and Networking Conference (WCNC), 2016 IEEE*. IEEE, 2016, pp. 1–6.
- [20] J. Prados-Garzon, J. J. Ramos-Munoz, P. Ameigeiras, P. Andres-Maldonado, and J. M. Lopez-Soler, “Latency evaluation of a virtualized MME,” in *Wireless Days (WD), 2016*. IEEE, 2016, pp. 1–3.

- [21] G. Premsankar, K. Ahokas, and S. Luukkainen, “Design and implementation of a distributed mobility management entity on OpenStack,” in *Cloud Computing Technology and Science (CloudCom), 2015 IEEE 7th International Conference on*. IEEE, 2015, pp. 487–490.
- [22] A. Banerjee, R. Mahindra, K. Sundaresan, S. Kasera, K. Van der Merwe, and S. Rangarajan, “Scaling the LTE control-plane for future mobile access,” in *Proceedings of the 11th ACM Conference on Emerging Networking Experiments and Technologies*. ACM, 2015, p. 19.
- [23] A. Machen, S. Wang, K. K. Leung, B. J. Ko, and T. Salonidis, “Live service migration in Mobile Edge Clouds,” *IEEE Wireless Communications*, vol. 25, no. 1, pp. 140–147, 2018.
- [24] E. Cau, M. Corici, P. Bellavista, L. Foschini, G. Carella, A. Edmonds, and T. M. Bohnert, “Efficient exploitation of Mobile Edge Computing for virtualized 5G in EPC architectures,” in *Mobile Cloud Computing, Services, and Engineering (MobileCloud), 2016 4th IEEE International Conference on*. IEEE, 2016, pp. 100–109.
- [25] N. Nikaein, X. Vasilakos, and A. Huang, “LL-MEC: Enabling low latency edge applications,” in *CLOUDNET 2018, IEEE International Conference on Cloud Networking, 22-24 October 2018, Tokyo, Japan, Tokyo, JAPAN, 10 2018*. [Online]. Available: <http://www.eurecom.fr/publication/5656>
- [26] “A low latency Multi-access Edge Computing platform for Software-Defined Mobile Network.” [Online]. Available: <http://mosaic-5g.io/ll-mec/>
- [27] “ETSI TS 129 281 V14.1.0 (2017-07).” [Online]. Available: http://www.etsi.org/deliver/etsi_ts/129200_129299/129281/14.01.00_60/ts_129281v140100p.pdf
- [28] ONF, “OpenFlow switch specification, version 1.5.1.” [Online]. Available: <https://www.opennetworking.org/wp-content/uploads/2014/10/openflow-switch-v1.5.1.pdf>
- [29] “Open vSwitch.” [Online]. Available: <https://www.openvswitch.org/>
- [30] “datapath: add vport-gtp for GPRS Tunneling Protocol.” [Online]. Available: <https://patchwork.ozlabs.org/patch/787468/>
- [31] “userspace: Add L3 tunnel type GTP.” [Online]. Available: <https://patchwork.ozlabs.org/patch/787467/>
- [32] K. He, J. Khalid, A. Gember-Jacobson, S. Das, C. Prakash, A. Akella, L. E. Li, and M. Thottan, “Measuring control plane latency in SDN-enabled switches,” in *Proceedings of the 1st ACM SIGCOMM Symposium on Software Defined Networking Research*. ACM, 2015, p. 25.