

A Survey on Split Manufacturing: Attacks, Defenses, and Challenges

TIAGO D. PEREZ, SAMUEL PAGLIARINI

Tallinn University of Technology (TalTech)
Department of Computer Systems
Centre for Hardware Security
Tallinn, Estonia
(e-mails: {tiago.perez,samuel.pagliarini}@taltech.ee)

Corresponding author: T. D. Perez (e-mail: tiago.perez@taltech.ee).

This work was supported by the European Union through the European Social Fund in the context of the project "ÅIICT programme".

arXiv:2006.04627v1 [cs.CR] 8 Jun 2020

ABSTRACT

In today's integrated circuit (IC) ecosystem, owning a trusted foundry is not economically viable and therefore most IC design houses are now working under a fabless business model. In order to overcome the security concerns associated with fabrication outsourcing, the Split Manufacturing technique was proposed. In Split Manufacturing, the Front End of Line (FEOL) layers (transistors and lower metal layers) are fabricated at an untrusted high-end foundry, while the Back End of Line (BEOL) layers (higher metal layers) are manufactured at a trusted low-end foundry. This approach hides the BEOL connections from the untrusted foundry, thus preventing overproduction and piracy threats. However, many works demonstrate that BEOL connections can be derived by exploiting layout characteristics that are introduced by heuristics employed in typical floorplanning, placement, and routing algorithms. Since straightforward Split Manufacturing may not afford a desirable security level, many authors propose defense techniques to be used along with Split Manufacturing. In this work, we present a detailed overview of the technique, the many types of attacks towards Split Manufacturing, as well as possible defense techniques described in the literature. For the attacks, we present a concise discussion on the different threat models and assumptions, while for the defenses we classify the studies into three categories: proximity perturbation, wire lifting, and layout obfuscation. The main outcome of our survey is to highlight the discrepancy between many studies – some claim netlists can be reconstructed with near perfect precision, while others claim marginal success in retrieving BEOL connections. Finally, we also discuss future trends and challenges inherent to Split Manufacturing, including the fundamental difficulty of evaluating the efficiency of the technique.

INDEX TERMS Hardware Security, Hardware Trojans, Integrated Circuits, IP Theft, Reverse Engineering, Split Manufacturing

I. INTRODUCTION

Counterfeiting and intellectual property (IP) infringement is a growing problem in several industrial sectors, including the electronics sector. In Europe, for instance, seizures of counterfeit electronics products increased by almost 30% when comparing the 2014-2016 and 2011-2013 periods [1]. Legitimate electronics companies reported about \$100 billion in sales loss every year because of counterfeiting [2].

As electronic systems are being increasingly deployed in critical infrastructure, counterfeited and maliciously modified integrated circuits (ICs) have become a concern. The globalized nature of the IC supply chain contributes to the problem as we lack the means to assess the trustworthiness

of the design and fabrication of ICs. It is foreseeable that a fault in a low-quality counterfeit or a malicious modified IC will disrupt critical infrastructure – with grave consequences. Therefore, hardware security has gained more attention in the past decades, emerging as an important research topic.

As the IC supply chain has become more globalized, ensuring the integrity and trustworthiness of ICs becomes more challenging [3]. When a modern IC is conceived, the probability that all involved parties are trusted is close to zero. The process of conceiving an IC can be broken down in three major steps: design, manufacturing, and validation. Designing an IC involves arranging blocks and their interconnections. Some blocks are in-house developed, while

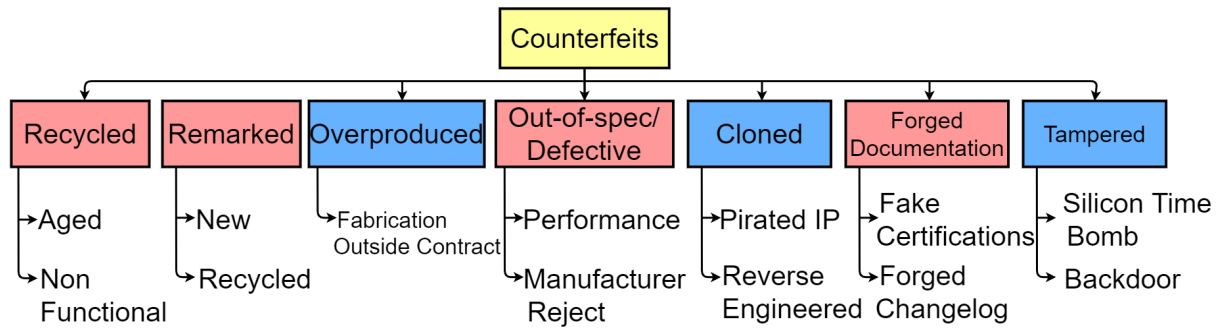

FIGURE 1: Counterfeit Electronics Taxiderm (Adapted from [3]).

some are third-party IPs. Finally, a layout is generated by instantiating libraries that might also be in-house developed or provided by third parties. The resulting layout is then sent to a foundry for manufacturing. The process of validation requires test for physical defects as well as verification of packaged parts for correct functionality. Both test and packaging facilities may be untrusted, as these efforts are often offshored. Thus, in order to produce an IC, sensitive information almost inevitably is exposed to untrusted parties. Today's reality is that ICs are vulnerable to many hardware-based threats, including insertion of hardware trojans, IP piracy, IC overbuilding, reverse engineering, side-channel attacks and counterfeiting.

Hardware trojans are malicious modifications to an IC, where attackers insert circuitry (or modify the existing logic) for its own malicious purposes. This type of attack is mounted during manufacturing, as the foundry holds the entire layout and can easily identify key-locations for modifications. Third-party IPs can also contain trojans/backdoors that may contain hidden functionalities, and which can be used to access restricted parts of the design and/or expose data that would otherwise be unknown to the adversary.

IP piracy and IC overbuilding are, essentially, illegal ownership claims of different degrees. As said before, during designing an IC, third-party and in-house developed IPs are utilized. The untrusted foundry (or a rogue employee of it) can copy an IP without the owner's authorization. Similarly, malicious foundries can manufacture a surplus of ICs (overbuilding) without the owner's knowledge, and sell these parts in the grey market.

Reversing engineering an IC has been extensively demonstrated [4]. An attacker can identify the technology node and underlying components (memory, analog, and standard cells), from which a gate-level netlist is extracted and even a high-level abstraction can be inferred [5]. Reverse engineering can be effortlessly executed during manufacturing, as the foundry holds the entire layout and most likely holds the IP as well. After fabrication, when ICs are already packaged and in the field, reverse engineering is more laborious but can be executed by a knowledgeable adversary.

According to [3], counterfeited components are classified into seven distinct categories, as illustrated in Fig. 1. Recy-

cloned, remarked, out-of-spec/defective and forged documentation are intrinsic after-market problems, where products are offered by parties other than the original component manufacturer or its authorized vendors. On the other hand, overproducing, cloning, and tampering are problems faced during the designing and/or fabrication. For this reason, in this paper, we will focus on these threats. It is important to realise that these threats could be avoided if a trusted fabrication scheme was in place. However, the escalating cost and complexity of semiconductor manufacturing on advanced technologies made owning a trusted advanced foundry unfeasible. Design companies now have the tendency to adopt the fabless business model [6]. Consequentially, outsourcing of the manufacturing exposes their entire layout to untrusted foundries, leaving their designs vulnerable to malicious attacks.

While many *ad hoc* techniques have been proposed to individually combat these threats, very few solutions directly address the lack of trust in the fabrication process. Split Manufacturing stands out from other techniques as it promotes a hybrid solution between trusted and untrusted fabrication. The technique was first pitched to DARPA circa 2006 in a white paper authored by Carnegie Mellon and Stanford universities. Later, it was picked by IARPA which launched the Trusted IC program [7] that stewarded much of the research in the area and led to this survey.

In Split Manufacturing, the key concept is to split the circuit in two distinct parts before manufacturing, one containing the transistors and some routing wires, and the other containing only the remaining routing wires. These parts are then fabricated in different foundries. The anatomy of an IC is illustrated in Fig. 2 (adapted from [8]), containing two sets of layers, the bottom layer where the transistors are built, called Front end of the Line (FEOL), and the top layer where the metal layers are built for routing purposes, called Back end of Line (BEOL). In Split Manufacturing, the FEOL is first manufactured in a high-end foundry, and later the BEOL is stacked on top of it by a second (and possibly low-end) foundry. This process requires electrical, mechanical, and/or optical alignment techniques to ensure the connections between them. Additionally, FEOL and BEOL technologies have to be compliant with each other [9], regarding the

metal dimension rules where the split is done, which can be done after metal layer M1. If the technologies are vastly different from one another, Split Manufacturing may incur heavy overheads.

In this work, Split Manufacturing technique is the focus. As described above, Split Manufacturing can tackle threats that occur during the fabrication. It avoids overproduction, reverse engineering (to some extent) and unwanted modifications, limiting the capability of attackers. In Section II, we provide a background and more in-depth explanation of the technique. We address security threats in Section II, demonstrating the potential vulnerabilities found in split circuits and describing the state-of-the-art attacks proposed until the present day. In Section IV, split circuits security is discussed, showing how it can be improved using security enhancements techniques. Future trends and lessons learnt are discussed in Section V. Finally, our conclusions are presented in Section VI.

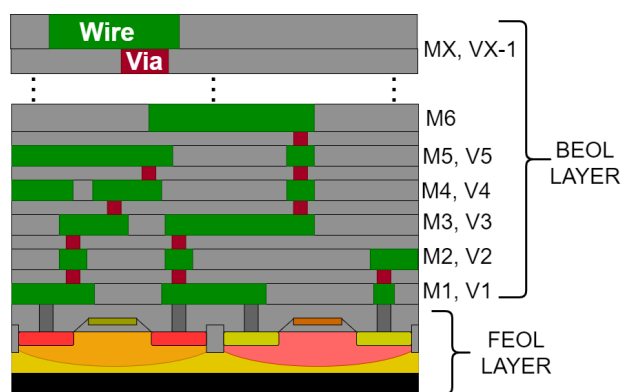

FIGURE 2: Anatomy of an integrated circuit (Adapted from [8])

II. SPLIT MANUFACTURING: BACKGROUND

As mentioned before, in order to have access to advanced technologies, many design companies have to outsource their IC manufacturing to untrusted high-end foundries. Protecting their designs against threats that may occur during manufacturing is a concern. Designs can be protected by applying the Split Manufacturing technique, thus combating all threats highlighted in Fig. 2 to enhance the IC security during manufacturing.

Split Manufacturing protects a design by hiding sensitive data from the untrusted foundry. This is achieved by splitting the IC into two parts before manufacturing, a horizontal cut that breaks the circuit into one part containing the transistors and some (local) routing wires, and another containing only routing wires. These parts are termed FEOL and BEOL.

As the FEOL and the BEOL of an IC are built sequentially, first FEOL and then BEOL, this characteristic enables the Split Manufacturing technique. Since the FEOL contains the transistors and possibly a few of the lowest ultra-thin metal layers – the most complex parts of an CMOS process [10] –,

it is logical to seek to use a high-end foundry for its manufacturing, even if said foundry is not trusted. Completing the IC can then be done in a trusted low-end foundry, where the BEOL is stacked on top of the FEOL. Split Manufacturing was successfully demonstrated [9], [11], [12], where designs were manufactured with ~0% of faults, and are reported to present a performance overhead of about 5%. Therefore, design companies can make use of advanced foundries without fully exposing their layouts for manufacturing.

However, there are many caveats to Split Manufacturing. The technique can be successfully applied only if the technologies used to build the FEOL and BEOL are “compatible”. In theory, a layout can be split at any metal layer if the chosen layer presents a good interface between FEOL and BEOL. Since advanced technologies utilize the dual-damascene fabrication process, the layout can only be split on metal layers [13], thus, the FEOL cannot terminate in a via. The dual-damascene process is characterized by patterning the vias and trenches in such a way that the metal deposition fills both at the same time, i.e., via-metal pairs (e.g., VIA1 and M2) must mandatory be built by the same foundry.

Two technologies are said to be compatible with each other if there is a way for a BEOL via to land on the FEOL uppermost layer while respecting all design rule checks (DRCs) of both technologies. DRCs are used to guarantee the manufacturability and functionality of an IC, and are defined with respect to the characteristics of the materials utilized and to tolerance ranges of the manufacturing processes (e.g., polishing, patterning and deposition). These rules encompass minimum enclosure, width, spacing, and density checks.

Modern technologies have several options for via shapes. As long as one via shape is valid, the technologies are compatible for Split Manufacturing purposes. However, in practice, to keep the overhead of the technique under control, an array of via shapes must be feasible, thus providing the physical synthesis with a rich selection. According to [9], compatibility between two technologies can be generalized by enclosure rules as in Eq. 1, where $MW.U.x$ is the minimum width of Mx on untrusted foundry, $VW.T.x$ is the minimum width of Vx on trusted foundry and $EN.T.x$ is the minimum enclosure on trusted foundry. As illustrated in Figure 3, the minimum enclosure width, $Mx.EX.Vx$, must be compatible between the two foundries. In modern technologies, Eq. 1 is no longer sufficient as it does not capture the intricate rules for vias and line endings (enclosure from 1 side, 2 sides, 3 sides, T-shaped/hammerheads, etc.).

$$MW.U.x \geq VW.T.x + (2EN.T.x) \quad (1)$$

Split Manufacturing also presents challenges on the design flow front, which is illustrated in Fig. 4. An in-house team designs the circuit, from RTL to layout. Most likely, the layout contains IPs obtained from third parties. Depending on the metal layer where the layout is to be split, it may affect existing IP. Logic and memory IP may use higher metal layers – memories typically require 4 to 5 metal layers, while

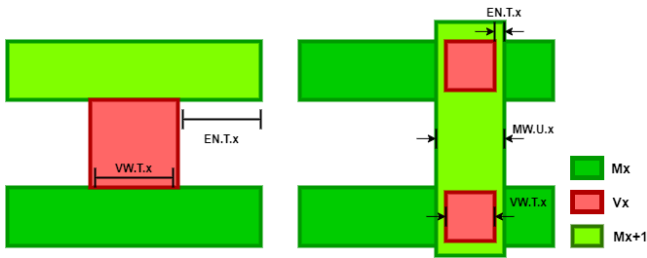

FIGURE 3: Compatibility Metal Dimensions Between FEOL and BEOL.

standard cells typically require 2 metal layers –, limiting where the split can be done. Standard cells and memories have to be re-designed if they use metal layers that will be split, a grave challenge that may render Split Manufacturing no longer feasible.

Still referring to Fig. 3, the FEOL and BEOL are generated using a hybrid process design kit (PDK), and then later split to be manufactured. After splitting the layout correctly, the FEOL is first manufactured in a high-end foundry, and later the BEOL is stacked on top of it by a second (and possibly low-end) foundry.

Even by splitting the layout, it is often argued that the FEOL exposes enough information to be exploited. Attacks towards the FEOL can effectively retrieve the BEOL connections by making educated guesses. The efficiency of the guessing process is inherently linked to the threat level assumed, which determines the information the attacker possesses to begin with. The literature describes two distinct threat models:

- **Threat model I:** an attacker located at the untrusted foundry holds the FEOL layout and wants to retrieve the BEOL connections.
- **Threat model II:** an attacker located at the untrusted foundry holds the entire gate-level netlist that is assumed to be provided by a malicious observer. The attacker here still holds the FEOL layout and wants to retrieve the BEOL connections. [14].

It is important to emphasize that the second threat model completely nullifies the security introduced by Split Manufacturing. Possessing the gate-level netlist makes reverse engineering the layout trivial, as if the attacker held the entire layout, not only the FEOL. Assuming the attacker has knowledge about the netlist challenges the design company integrity. It could be argued that this vulnerability is so severe that Split Manufacturing virtually stops making sense. For this reason, threat model I is the focus in this work. However, as our goal is to present a comprehensive survey, related works that used threat model II will be covered as well.

Assuming the threat model I, an attacker already knowing all the layers that make up the FEOL, has the interested in retrieving the BEOL connections to recreate the full design (or as close as possible). The commonly used assumption is that attackers are powerful and work within the untrusted

foundry in some capacity. Thus, the attackers have deep understanding about the technology. Extracting the (still incomplete) gate-level netlist from a layout is, therefore, a trivial task.

Many approaches to retrieve the BEOL connectivity have been proposed, several of which are term *proximity attacks* [8], [15], [16]. Since EDA tools focus on optimizing power, performance, and area (PPA), the solution found by a placement algorithm (that uses heuristics internally) tends to place connected cells close to one another as this would in turn reduce area, wirelength, and delay. Therefore, finding the correct missing connections between FEOL and BEOL can be done by assessing input and output pins that are in proximity (thus, the name proximity attack). The more input and output pins to connect, the higher is the probability to make a wrong connectivity guess. Thus, higher level of security is achieved by splitting the circuit at the lowest metal layer possible.

As a promising technique to enhance the security of ICs in this era of fabless chip design, Split Manufacturing still faces some enormous challenges:

Logistical challenge: Split Manufacturing is not presently incorporated into the IC supply chain. Finding foundries with compliant technologies that are willing to work with each other is not trivial.

Technological challenge: even within compliant technologies, non-negligible overheads can be introduced if they are vastly different¹. In the worst case scenario, it can make routing impossible. Thus, this fact narrows down the technology choices available.

Security challenge: the attained security of straightforward Split Manufacturing is still under debate. Attacks towards the FEOL can be effective, where the hidden connections can be retrieved.

For the purpose of this survey, we categorize related works in the literature as attacks and defense. In *attacks*, authors propose new attack models or modifications of existing attacks in order to improve their effectiveness. In *defenses*, authors propose new techniques to use together with Split Manufacturing in order to improve its security level.

III. ATTACKS ON SPLIT MANUFACTURING

The Split Manufacturing technique was developed to protect ICs against threats related to manufacturing in potentially untrusted foundries. In practical terms, to split the layout means to hide some connections from the untrusted foundry. The security provided by Split Manufacturing is based on the fact that the attacker in the FEOL foundry cannot infer the missing BEOL connections. This assumption, however, was challenged by several works where authors proposed attack approaches that can potentially retrieve the missing connections with varying degrees of success. In the text that follows, we present works that proposed Split Manufacturing attacks. These attacks are discussed in chronological order,

¹For a thorough discussion and silicon results on BEOL-related overheads, please refer to [17].

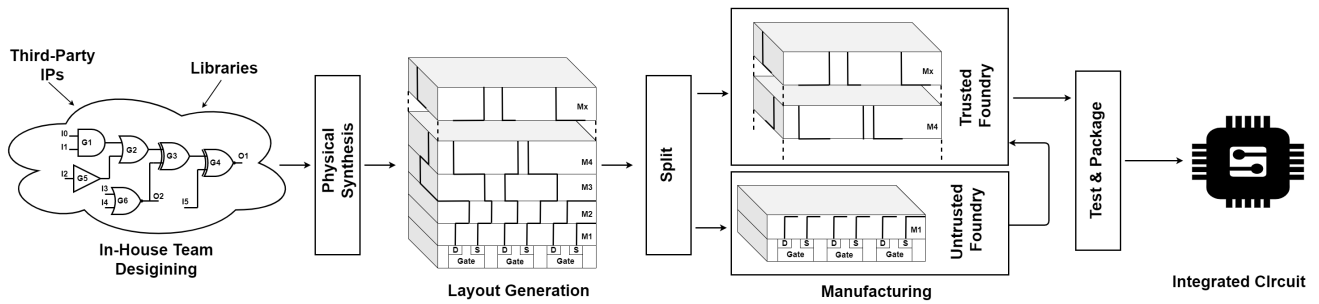

FIGURE 4: Split Manufacturing Design Flow.

compiled in Tab. 1. These works are divided by threat model, attack type, novelty and benchmark circuits used for their experiments.

The first reported attack is by Jeyavijayan *et al.* and is described in [8]. In this work, the authors assume that naive Split Manufacturing (i.e., splitting a layout without care for the connections) is inherently insecure. They introduced the concept of proximity attacks that exploits “vulnerabilities” introduced by EDA design tools. Since EDA tools focus on optimizing power, performance, and area (PPA), the solution found by a placement algorithm (that uses heuristics internally) tends to place logically connected cells close to one another so they become physically connected during routing. This heuristic, in turn, reduces area, wirelength, and delay. Therefore, the distance between output-input pairs can be used as a metric to recover the missing BEOL connections.

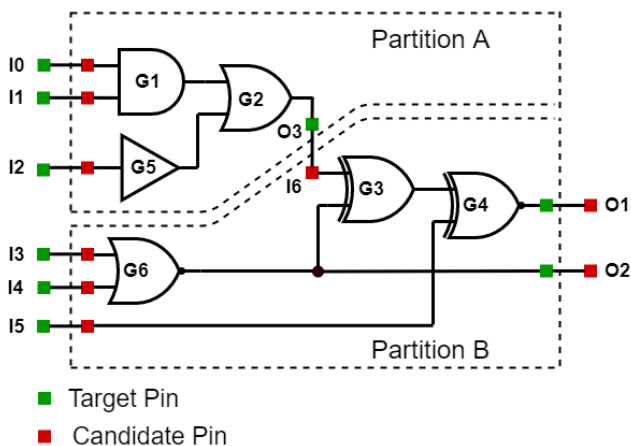

FIGURE 5: Circuit Partitioned Example.

Designs are commonly partitioned for its physical implementation, i. e., separated into small logical blocks with few connections between them. That way, the designer have total control of the floorplaning regarding the blocks placement. And also, they can be separately implemented and later integrated, creating a sense of parallelism in the design flow, which can reduce the overall physical implementation time. Consider as example the circuit illustrated in Fig. 5, partitioned into partition A and B. The input pins. Consider

a target output pin $P_{x,A,out}$ and its corresponding candidate input pin $P_{x,B,in}$. During placement, the EDA tool will attempt to place the pin $P_{x,A,out}$ as close as possible to $P_{x,B,in}$ than any other pin in partition B. Using this information, an attacker may recover the connections missing in the FEOL layout, performing then a proximity attack. The authors argue that their proposed attack flow is successful due to being able to leverage the following “hints” provided by the EDA tools:

Hint 1 - Input-Output Relationship: input partitions pins are connected either to another partition output pin or to an input port of the IC (i.e., input to input connections are excluded from the search space).

Hint 2 - Unique Inputs per Partition: input-output pins between partitions are connected by only one net. If a single partition output pin feeds more than one input pin, the fan-in and fan-out nodes are usually placed within the partitions (i.e., one-to-many connections are ruled out from the search space).

Hint 3 - Combinational Loops: in general, only very specific structures are allowed to utilize combinational loops (e.g., ring oscillators). These structures are very easy to identify. In most cases, random logic does not contain combinational loops (i.e., connections that would lead to combinational loops can be excluded from the search space).

An attacker can correctly connect a target pin to a candidate pin by identifying the closest pin from a list of possible candidates. The list of possible candidates is created by observing the three hints mentioned above. A possible candidate pin is an unassigned output pin of another partition and an unassigned input port of the design. Then, a minimum distance metric is used to connect the pins, based on the previously discussed heuristics of EDA tools.

In Algorithm 1, we describe the proximity attack detailed in [8]. The input to the algorithm is the FEOL layout, from which the information about unassigned input-output ports can be derived. The algorithm does not describe the specifics of how to derive a netlist from a layout. However, the complexity of this task is rather straightforward. It is assumed that the attacker possess information about both the PDK and the standard cell library. In many cases, the untrusted foundry is

the actual provider of both². From there, a layout in GDSII or OASIS format can be easily reverted to a netlist by any custom design EDA tool.

Algorithm 1: Proximity attack

Input: FEOL layers
Output: Netlist with BEOL connections

- 1 Reverse engineer FEOL layers and obtain partitions;
- 2 **while** *Unassigned partition pins or ports exist* **do**
- 3 Select arbitrary unassigned pin/port as a *targetPin*;
- 4 *ListOfCandPins* = *BuildCandPinsList(targetPin)*;
- 5 Select *candPin* from *ListOfCandPins* that is closest to *targetPin*;
- 6 Connect *targetPin* and *candPin*;
- 7 Update netlist;
- 8 **Return:** netlist
- 9 **BuildCandPinsList(targetPin)**
- Input:** *targetPin* $P_{X,i,in}$
- Output:** *CandPins* for *targetPin*
- 10 *CandPins* = Unassigned output pins of other partitions + unassigned input ports of the design;
- 11 **for each** $P_{in,j} \in \text{CandPins}$ **do**
- 12 **if** *CombinationalLoop(targetPin, Pin_j)* **then**
- 13 *CandPins* -= $P_{in,j}$;
- 14 **Return:** *CandPins*

From the gate-level netlist, the algorithm chooses an arbitrary *TargetPin* from the unassigned partition input pins and output ports, creates a list of possible *CandidatePins*, and connects the *TargetPin* to the closest pin in this list. After each connection, the netlist is updated. This procedure is repeated until all unassigned ports are connected. When the procedure is over, the attacker obtains the possible missing BEOL connections. If all guesses were correct, the original design has been reverse engineered and Split Manufacturing has been defeated.

Algorithm 1 was originally applied to the ISCAS'85 [23] suite of benchmark circuits. These circuits were selected and published to help in comparing automatic test generation (ATPG) tools. Due to the small size of these circuits, they may not be the best option to assess the effectiveness of Split Manufacturing. The authors reported an effectiveness of 96% of Correct Connection Rate (CCR) for the c17 circuit (largest circuit in ISCAS'85 suite), demonstrating that the algorithm is capable of retrieving the missing BEOL connections. In Tab. 2, we highlight the best and worst results in terms of CCR.

Jeyavijayan *et al.* [8] were the first to question the security of straightforward Split Manufacturing, showing promising results from their proximity attack, even if the considered

²For the PDK, it is very natural that it is created by the untrusted foundry itself. For standard cell libraries, the cells might be designed by the foundry or by a third-party licensed by the foundry. In either case, the effort to revert a layout to a netlist remains trivial.

benchmark circuits are rather small in size. This was the starting point for other studies proposing different attacks to Split Manufacturing in an attempt to retrieve the missing BEOL connections. Improvements over the original proximity attack, as well as other attacks, are compiled in Tab. 1.

The effectiveness of the proximity attack utilizing distance of unassigned pins alone as metric to find missing BEOL connections was questioned by Magaña *et al.* [18]. The authors propose to utilize both placement and routing information in proximity attacks. For their results, large-sized circuits from the ISPD-2011 routability-driven placement contest [24] were used. These benchmarks are better representatives of modern circuits as they contain 9 metal layers and up to two million nets in a design. Thus, in an attempt to increase the success rate of the attack for large-sized circuits, they proposed routing-based proximity in conjunction with placement-centric proximity attacks.

A key difference present in [18] is that it utilizes a different threat model (model II), claiming that the untrusted foundry possesses information about the the entire place & routed netlist, as well as the FEOL layout. This assumption is hard to reason if the attacker's intent was to overproduce the IC or pirate the IP. For these goals, clearly, this assumption is unnecessary. The attacker himself can, if he indeed possesses the netlist, perform his own physical synthesis and generate his own layout. The interest in reverse engineering the BEOL connections of the original design diminishes. Nevertheless, we report on the strategies employed by the authors of [18] since they build on the approach proposed by [8].

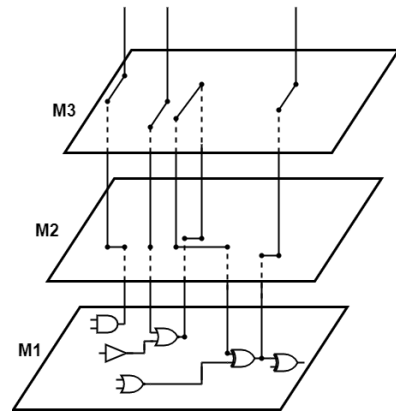

FIGURE 6: Layout Circuit Abstraction For the First 3 Metal Layers

Regarding the attacks, the authors of [18] proposed four different techniques to identify a small search neighborhood for each pin. The goal is to create a neighborhood that is small enough to make further pruning feasible, and therefore increase the likelihood of including the matching pins. The techniques are called *placement proximity*, *routing proximity*, *crouting proximity* and *overlap of placement and routing proximity*, and are described in the text that follows. The circuit illustrated in Fig. 6 is the example (before the split) that will guide the discussion on these four techniques.

TABLE 1: Threat Models, Attacks and Metrics.

Work	Year	Threat Model	Attack type	Novelty	Benchmark suite(s)	Largest circuit size (gates)	Size Average
[8]	2013	I	Proximity	Attack Based on Proximity	ISCAS'85	3.51K	1288
[18]	2016	II	Proximity	Placement and routing proximity used in conjunction	ISPD'11	1.29M	951k
[19]	2018	I	Proximity	Network-Flow-Based with Design Based Hints	ISCAS'85 & ITC'99	190.21K	9856
[20]	2018	I	Proximity	Proximity Attack Based on Machine Learning	ISPD'11	1.29M	951k
[21]	2019	I	SAT	SAT Attack without Proximity Information	ISCAS'85 & ITC'99	190.21K	9856
[22]	2019	I	SAT	SAT attack dynamically adjusted based on proximity information	ISCAS'85 & ITC'99	190.21K	9856

TABLE 2: Benchmarks Size and Attacks Results Comparison.

Work	Benchmark	Attack	Split Layer	Size (In Gate Count)	Metric	Result
[8]	c17	Proximity	Not Defined	6	CCR(%)	100
[8]	c7552	Proximity	Not Defined	3513	CCR(%)	94
[18]	Superblue 1	Placement Proximity	M2	847k	% Match in List	12.84
[18]	Superblue 1	Placement Proximity	M2	847k	CCR(%)	5.479
[18]	Superblue 1	Routing Proximity	M2	847k	% Match in List	71.08
[18]	Superblue 1	Routing Proximity	M2	847k	CCR(%)	0.651
[18]	Superblue 1	Overlap (P&R) Proximity	M2	847k	% Match in List	13.05
[18]	Superblue 1	Overlap (P&R) Proximity	M2	847k	CCR(%)	3.977
[18]	Superblue 1	Crouting Proximity	M2	847k	% Match in List	82.08
[18]	Superblue 1	Crouting Proximity	M2	847k	CCR(%)	0.651
[19]	c7552	Network-flow Based Proximity	Not Defined	3513	CCR(%)	93
[19]	c7552	Proximity	Not Defined	3513	CCR(%)	42
[19]	B18	Network-flow Based Proximity	Not Defined	94249	CCR(%)	17
[19]	B18	Proximity	Not Defined	94249	CCR(%)	< 1
[20]	Superblue 1	Proximity	M6	847k	% Match in list	33.40
[20]	Superblue 1	Proximity	M6	847k	CCR(%)	0.76
[20]	Superblue 1	ML	M6	847k	% Match in list	83.12
[20]	Superblue 1	ML	M6	847k	CCR(%)	1.91
[20]	Superblue 1	ML-imp	M6	847k	% Match in list	74.65
[20]	Superblue 1	ML-imp	M6	847k	CCR(%)	2.11
[20]	Superblue 1	ML-imp	M4	847k	% Match in list	75.45
[20]	Superblue 1	ML-imp	M4	847k	CCR(%)	2.58
[21]	c7552	SAT Attack	Not Defined	3513	Logical Equivalence(%)	100
[21]	B18	SAT Attack	Not Defined	94249	Logical Equivalence(%)	100
[22]	c7552	Improved SAT Attack	Not Defined	3513	Logical Equivalence(%)	100
[22]	B18	Improved SAT Attack	Not Defined	94249	Logical Equivalence(%)	100

Placement proximity exploits the placement information of cells. Each split wire is taken from the pin location of the corresponding standard cell that is connected to it. A search neighborhood is defined as a square centered around the corresponding pin with an area equal to the average areas of the bounding boxes (BB) in a typical design. The authors argue that it can also be measured based on BBs of the non-split wires in the design under attack, under the assumption that the number of wires that remain in the FEOL is also very large in practice. Considering the circuit illustrated in Figure 6 before the split as example. If the split is done at M2, the search area defined using the placement proximity would be as illustrated in Fig. 7 (a). Note that the layer at which the layout is split does not affect the search area defined by the placement proximity.

Routing proximity exploits the routing information. First, for each split wire, pins are identified as the point where the wire is actually cut at the split layer, i.e., the via location.

Next, a square area centered around those pins is defined. The size of the square area is defined based on the average BBs of the pins on that layer in the design. This procedure for identifying results in different search neighborhood sizes according to the split layer location, i.e., the search radius adapts to the routing resources of each layer. A search area defined using routing proximity is illustrated in Fig. 7 (b).

Crouting proximity takes into account routing congestion by exploiting the union of placement and routing proximity. The search area for each pin is define in such way that the ratio of number of pins to the search area is equal across all the pins in the split layer. Thus, if a pin is located at a high routing congestion area, the search area will be expanded until the pin density in the new search area reaches a target value or the search area grows to four times its starting value. The starting value is set according to the split layer, set as the average of numbers of pins which fall within a BB. A search area defined using crouting proximity is illustrated in Fig. 7

(c).

The last strategy proposed by [18] also combines placement and routing information. It is referred to as *Overlap of placement and routing proximities*. The concept here is to include a subset of pins identified by the placement proximity list which have their corresponding pins included in the routing proximity list. According to the author, intuitively, the overlap then identifies a subset of pins which may be more likely to point towards the direction of the matching pin. A search area defined using the overlap of placement and routing proximities is illustrated in Fig. 7 (d).

Magaña et al. [18] assessed each strategy using the benchmark circuit *superblue1*. Different split layers were also considered. In Tab. 2, we compiled the results for split layer M2. By comparing the results, it becomes clear that no strategy was able to recover 100% of the missing BEOL connections. The best result was only 5.479% of CCR. This is in heavy contrast with the findings of [8]. However, the circuit sizes differ by orders of magnitude.

According to the authors of [18], proximity alone is no way sufficient to reverse engineer the FEOL. However, proximity attacks have merit as they can be used to narrow down the list of candidates to a significantly smaller size. Using routing proximity, in 82.08% of the cases, the search area defined contained the matched pin in the list of candidates. The authors also present results for split layer M8. We opt not to show these results in Tab. 2. Using the circuit *superblue1* as example, the number of unassigned pins when the circuit is split at M8 is only 1.2% of the pins when split at M2. Therefore, the small number of unassigned pins to be connected overshadows the large circuit used for their experiments. It must also be emphasized that splitting a circuit in such higher layers is rather impractical since M8 tends to be a very thick metal reserved for power distribution in typical 10-metal stacks. There is very little value in hiding a power distribution network from an adversary that wants to pirate an IP. Once again, we opt not to show this result in our comparisons.

A network-flow based attack model toward flattened designs was proposed by Wang et. al [19]. The authors argue that the proximity attack originally proposed by [8] utilizes hints that can be used only by hierarchical designs, and that lots of designs are flattened designs³. Based on the original proximity attack, they propose an proximity attack utilizing five hints: physical proximity, acyclic combinational logic circuit, load capacitance constraint, directionality of dangling wires, and timing constraint. Note that the first two hints are already described by [8] and [18]. The three novel hints are described below:

Load Capacitance Constraint: gates can drive a limited load to honor slew constraints. Typically, maximum load capacitance is constrained and has a maximum

³We highlight that best practices in circuit design have changed over the years. Hierarchical design was heavily utilized for many years, but it lost favor due to the difficulty in performing reasonable timing budgeting between the many blocks of a system. Thus, flattened designs are often used to facilitate timing closure.

value defined by the PDK and the standard cell characterization boundaries. Hence, an attacker will consider only connections that will not violate the load capacitance constraints.

Directionality of Dangling Wires: EDA tools route wires from a source to a sink node along the direction of the sink node. Therefore, the directionality of remaining dangling wires at lower metal layers may indicate the direction of their destination cell with a high degree of certainty⁴. An attacker can disregard connections in the other directions.

Timing Constraint: connections that create timing paths that violate timing constraints can be excluded. An attacker, through an educated guess of the clock period, can determine a conservative timing constraint and exclude any connections that would lead to slower paths.

The network-flow based attacked framework proposed by Yang et. al, considers two hints proposed by [8] plus the aforementioned hints to create a directed graph $G = (V, E)$, where V is a set of vertices and E is a set of edges. The set (V) is composed by the set of vertices corresponding to the output pins V_o , and a set corresponding to the input pins (V_i) , the source vertex (S) and the target vertex (T) . The set E consists of E_{So} , edges from S to every output pin vertex, E_{oi} , edges from output pin vertices to input pin vertices, and E_{iT} , which includes edges from every input vertex to the target vertex. An example of this kind of representation is shown in Fig. 8, where (a) is the circuit with missing connections, and (b) is the network-flow representation. The detailed problem formulation is omitted from this work. To find the connections, its used min-cost network-flow problem, where the decision variables are the flow $x_{i,j}$ going through each edge $(i, j) \in E$. The authors utilize the Edmonds-karp algorithm [25] to solve this problem. Complexity of the algorithm alone is given by $O(VE^2)$, however, its needed to run the algorithm V in the worst case, thus, the run-time of the complete network attack is given by $O(V^2E^2)$, assuming the worst case.

The network-flow approach was applied to ISCAS-85 and ITC-99 benchmark circuits. For comparison, they applied both the original proximity attack and the network-flow attack to flattened designs. As shown in Tab. 2, their network-flow proximity attack outperformed the original in terms of CCR. However, despite the evident improvement, the attack could only retrieve 17% of the missing BEOL connections for a medium sized circuit (b18 from the ITC-99 suite).

A Machine Learning (ML) framework was used by Zhang et al. [20] in an attempt to improve the attack proposed in [18]. They used the same setup as previously discussed. However, they incorporated more layout features as placement, routing, cell sizes, and cell pin types in their ML formulation.

⁴Metals usually have preferred directions that alternate along the stack (i.e., if M1 is vertical, then M2 is horizontal). Therefore, this hint becomes more effective if the attacker can observe more than one routing layer of the FEOL

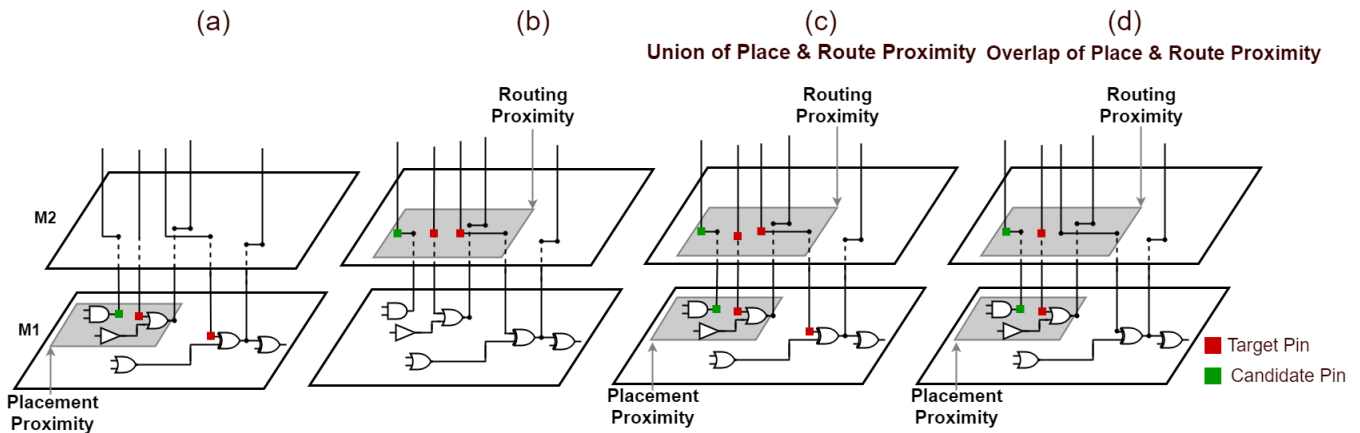

FIGURE 7: Multiple strategies for pin/connectivity search areas according to [18]

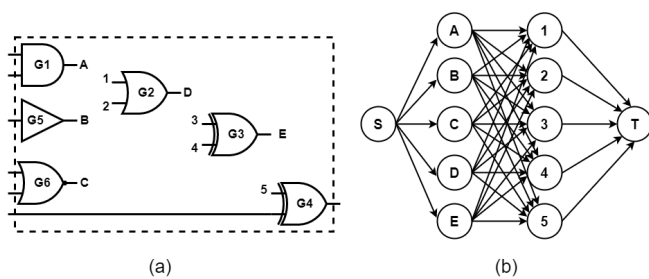

FIGURE 8: (a) Circuit with missing connections. (b) Network-flow model for inferring the missing connections. (Adapted from [19])

A high-level overview of their modeling framework is shown in Fig. 9 (a). First, they create a challenge instance from the entire layout and only FEOL view. Next, for each virtual pin (point where a net is broken on the split layer) they collect layout information, including placement, routing, cell areas, and cell pin as illustrated in Fig. 9 (b). Using this information, samples are generated which are fed into the ML training process. Each sample carries information for a pair of virtual pins which may or may not be matched. Classifiers then are build by the ML using training samples. After training and building the regression model, cross validation is used for evaluation which ensures validation of the model is done on the rest of the data which was not used for training. Their framework faces scaling issues when applied to lower split metal layers. An improved ML framework is then proposed as well, denoted by ML-imp, to solve the scaling issues.

For their experiments, Zhang *et al.* [20] utilizes the ISPD 2011 benchmark suite. They compare results from their last work [18], ML framework and ML-imp framework. However, they do not show results for lower split metal layers (e.g., M2). Instead, results are provider for M8, M6, and M4 splits. As pointed out before, utilizing higher layers for the split effectively shrinks the otherwise large circuits used in their experiments. A drastic reduction of unassigned pins is

expected for such higher layers, as higher metal layers are used often for power routing, not for signal routing. Results for the *superblue1* circuit are shown in Tab. 2. Regarding recovering missing BEOL connections, ML and ML-imp could only retrieve around 2%, therefore not showing a huge improvement when compared to their previous work. However, search list area accuracy showed significantly better results compared to their prior work. Besides obtained results, their machine learn framework needs the entire layout during its modeling. This characteristic may, in a best case scenario, nullify the applicability for an attacker that only holds the FEOL layout.

Attacks using proximity information as metric are not the only solution to recover missing BEOL connections. An effective methodology to apply a Boolean satisfiability based strategy is proposed by Chen *et al.* [21]. The authors claim that their attack methodology does not need or depend on any proximity information, or even any other insights into the nature of EDA tools during the design process. The key insight in their work is to model the interconnect network as key-controlled multiplexers (MUX). Initially, all combinations of signal connections between the FEOL partitions are allowed, as illustrated in Fig. 10. First, a MUX network is created in order to connect all missing paths in the circuit. This MUX network leads to potential cyclic paths, thus, there is a possibility to generate many combinational cycles during the attack process corresponding to incorrect key guesses. Therefore, constraints on the key values are generated in order to avoid activating the cyclic paths. The attack can be summarized in 4 steps: *identification of all cyclic paths, generation of cycle constraints, cycle constraints optimizations, and finally, SAT attack*. Chen *et al.* utilizes the SAT solver based attack method based on CycSat proposed by [26]. The SAT attack algorithm has as input the FEOL circuit with MUX network and the packaged IC that serves as an oracle, and as output MUX keys to yield correct BEOL nets.

In reality, [21] presents a different interpretation of threat model I since the attacker is assumed to possess a functional IC. This IC would then have to be available in the open mar-

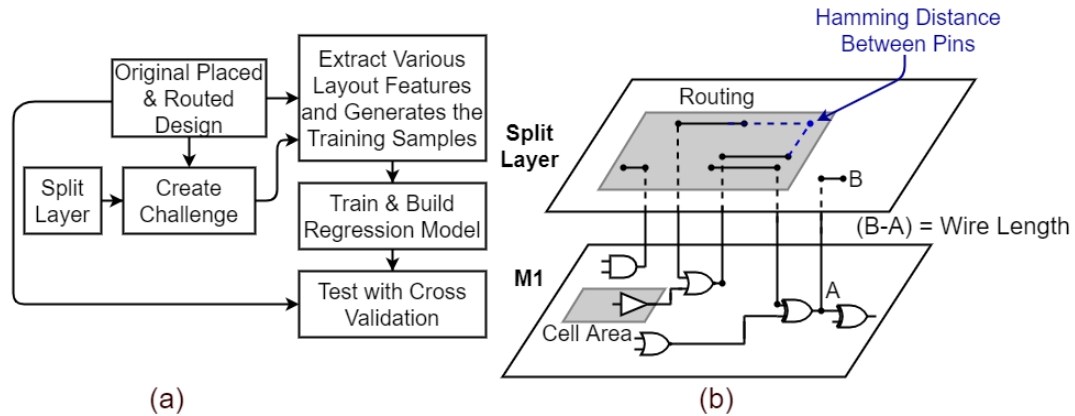

FIGURE 9: (a) Machine Learn Modeling by Zhang et al. [20]. (b) Few Layout Features Examples.

ket for being purchased by the attacker. This characteristic severely narrows down the applicability of this SAT attack. For instance, ICs designed for space or military use will not be freely available, thus an oracle is not known to the attacker.

Experimental results presented by [21] utilize ISCAS-85 and ITC-99 benchmark circuits. It has been shown that their attack could recover the correct logic circuit for all the circuits. However, there is a small caveat. In Tab. 2, two of those results are shown. For seven of the studied benchmarks (c1908, c2670, c5315, c7552, b14, b15, b17), the connections recovered are identical to the BEOL connections. For the remaining benchmarks, the recovered connections are not identical but logically equivalent to the original circuit. In practice, the logically equivalent circuit may present performance deviations from the original design. Matching the performance of the original design can be done by executing place and route using the logically equivalent gate-level netlist. Depending on the attack goal, it is possible that the attacker had already planned to execute the physical synthesis flow again (say, to resell the IP in a different form or shape). An attack that guarantees 100% of logic equivalence recovery is powerful enough, allowing attackers to copy and modify split layouts.

In order to increase the efficiency and capacity of SAT attack proposed in [21], the authors propose two improvements in [22]. First, the size of the key-controlled interconnect network that models the possible BEOL connections should be reduced. Second, after the MUX network is inserted into the FEOL circuit, the number of combinational cycles it induces in the design for incorrect key guesses should also be reduced. Proximity information is then exploited to achieve the proposed improvements. The improved SAT attack method which exploits proximity information showed significant reduction in the attack time and increase in the capacity. Same as in [21], the circuits tested were 100% recovered, as shown in Tab. 2.

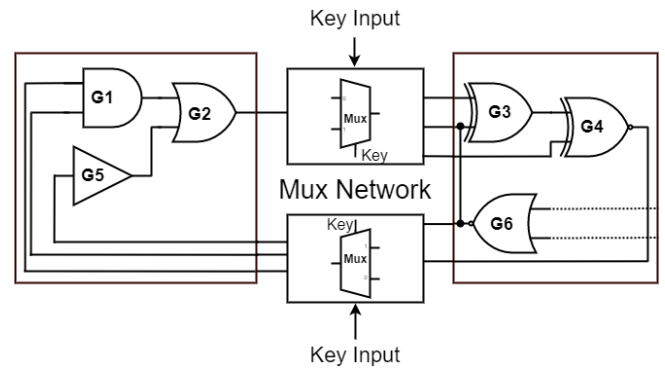

FIGURE 10: MUX Network for a Bipartitioned FEOL Circuit. (Adapted from [21])

IV. SPLIT MANUFACTURING DEFENSES

Attacks toward Split Manufacturing showed promising results, as described in the previous section. A malicious attacker has the real potential to recover the missing BEOL connections. If the missing connections are successfully recovered, the security introduced by applying the technique is nullified. Therefore, straightforward Split Manufacturing is questioned by several works. Several authors propose defense techniques that augment the technique, i.e., techniques that when used together with Split Manufacturing do increase the achieved security level against attacks. In Tab. 3, we compile a comprehensive list of defense techniques found in the literature. Each defense technique utilizes a different metric and threat model, depending upon the type of attack they are trying to overcome. Since many of the studied defense techniques often introduce heavy PPA overheads, Tab. 4 also shows if the studied work assessed overheads and which ones were addressed.

In the text that follows, the many defense techniques are divided into categories, namely Proximity Perturbation (i.e., change location of cells or pins), Wire Lifting (i.e., change routing to upper layers), and Layout Obfuscation (i.e., hide the circuit structure). We present the categories in this exact order. For some techniques, it is worth mentioning that

TABLE 3: Split Manufacturing Defenses

Work	Year	Threat Model	Category	Defense	Metrics	Defense Overheads Presented
[8]	2013	I	Proximity Perturbation	Pin Swapping	Hamming Distance	-*
[14]	2013	II	Wire Lifting	Wire Lifting	k-Distance	Power, Area, Delay and Wire-Length
[11]	2014	I	Layout Obfuscation	Layout Obfuscation for SRAMs and Analog IPs	-	Performance, Power and Area
[27]	2014	I	Layout Obfuscation	Obfuscation Techniques	Neighbor Connectedness and Entropy	Performance and Area
[28]	2015	I	Layout Obfuscation	Automatic Obfuscation Cell Layout	Neighbor Connectedness and Entropy	Performance, Power and Area
[29]	2015	I	Layout Obfuscation	Obfuscated Built-in Self-Authentication	Obfuscation Connection	Number of Nets
[18]	2016	I	Wire Lifting	Artificial Blockage Insertion	Number of Pins	-*
[30]	2016	I	Wire Lifting	Net Partition, Cell Hidden and Pin Shaken	-	-*
[15]	2017	I	Proximity Perturbation	Routing Perturbation	Hamming Distance	Performance and Wire-Length
[31]	2017	I	Wire Lifting	Secure Routing Perturbation for Manufacturability	Hamming Distance	Performance and Wire-Length
[32]	2017	I	Proximity Perturbation	placement-centric Techniques	CCR	Performance, Power and Area
[33]	2017	II	Proximity Perturbation	Gate Swapping and Wire Lifting	Effective Mapped Set Ratio and Average Mapped Set Pruning Ratio	Wire-Length
[34]	2018	I	Wire Lifting	Concerted Wire Lifting	Hamming Distance	Performance, Power and Area
[19]	2018	I	Proximity Perturbation	Secure Driven Placement Perturbation	Hamming Distance	Power and Wire-Length
[35]	2018	I	Proximity Perturbation	placement and routing perturbation	Hamming Distance	Performance, Power and Area
[36]	2019	I	Layout Obfuscation	Isomorphic replacement for Cell Obfuscation	Isomorphic Entropy	-*
[37]	2019	II	Layout Obfuscation	Dummy Cell and Wire Insertion	k-security	Area and Wire-Length

* Authors do not present any discussion regarding overhead.

overlaps do exist and that techniques could be categorized differently. Thus, this categorization is our interpretation of the state of the art and may not be definitive. Furthermore, the boundaries between categories are not strict. For example, a technique may perform a layout modification that promotes proximity perturbation and leads to (indirect) wire lifting.

A. PROXIMITY PERTURBATION

Attacks toward split circuits are generally based on leveraging proximity information. As previously mentioned, missing connections have a tendency to be close to one another. The first category of defenses, Proximity Perturbation, addresses this hint left by the EDA tools. The goal of the techniques within this category is to promote changes in the circuit such that the proximity information between the FEOL pins is less evident. Therefore, the success rate of the proximity attacks is decreased.

In [8], the authors propose pin swapping to overcome proximity attacks. Rearranging the partition pins can alter their distance in such way to deceive the attacker. As an example, if the pins $P_{G3,B,in}$ and $P_{G6,A,in}$ (Fig. 5) are swapped, the proximity attack will incorrectly guess the connection between $P_{G2,A,out}$ and $P_{G3,B,in}$. Thus, a sufficient number of pins have to be swapped in order to create a netlist that is significantly different from the original netlist (based on some sort of metric for similarity). In [8], Hamming distance is proposed as a way to quantify the difference between

the outputs of the original netlist and the modified netlist. The authors argue that the optimum netlist is created when the Hamming distance is 50%. Since the best rearrangement for N pins of partitions might take $N!$ computations (rather computationally expensive), pair-wise swapping of pins is considered in [8]. Pair-wise swapping of pins results in $O(N^2)$ computations.

The modified netlist is created based on a series of rules. Similarly to the proximity attack, a list of candidate pins to be swapped is created before the actual swap is applied. Since not every pin can be swapped, a candidate pin to be swapped should:

- be an output pin of the partition where the target pin resides
- not be connected to the partition where the candidate pin resides
- not form a combinational loop

Using the above constraints, a candidate pin is selected. The target pin also needs to be chosen carefully. In [8], IC testing principles [38] and hints from the original proximity attack are used to choose the target pin. The swapping procedure is described in Algorithm 2, where *TestingMetric* is a metric based on IC testing principles described in details in [8]. The proposed defense technique is validated using ISCAS'85 circuits and the original proximity attack. For the smallest circuit, c17, it took only one swap to achieve 50% of

Hamming Distance. For the largest studied circuit, c7552, it took 49 swaps. These results are summarized in Tab. 4.

As demonstrated in [8], rearranging the partition pins can thwart proximity attacks. However, according to Chen *et al.* [33], pin swapping at partition level has limited efficacy. They demonstrated that an attacker holding the FEOL layout as well as the nestlist can insert hardware trojans, even when the defense approach of [8] is applied. It must be highlighted that [33] assumes threat model II, which we have previously argued that has the potential to nullify the vast majority of defenses towards split circuits. Thus, they proposed a defense to counter the threat from hardware trojans attacks. Their defense incorporates the global wire-length information, with the goal to hide the gates from their candidate locations, and as result decreasing the effective mapped set ratio (EMSR). The EMSR metric is an attempt to quantify the ratio of real gates location of a given mapping during a simulated annealing-based attack. This defense consists of two steps, first a greedy gate swapping defense [19], and second, a measurement of the security elevation in terms of EMSR. The technique is evaluated using ISCAS'85 benchmarks circuits, and the EMSR metric to quantify the defense effectiveness. The results are shown in Tab. 4.

Following the same principle of increasing the Hamming Distance, Wang *et al.* [15] propose a routing perturbation based defense. The optimum Hamming distance is sought to be achieved by layer elevation, routing detour, and wire decoys, while testing principles are used to drive the perturbation choices. Layer elevation is essentially a wire lifting technique: without changing the choice of split metal layer, wires are forced to route using higher metal layers, thus being lifted from the FEOL to the BEOL. Intentional routing detour is a way to increase the distance between disconnect pins of the FEOL. If done properly, disconnected pins will not be the closest to each other, deceiving the proximity attack. In some cases, routing detour will increase the distance between disconnect pins, however, they still remain the closest to each other. In this scenario, wire decoys can be drawn near disconnected pins, in such a way that they are now the closest and will be picked as the ideal candidate pin.

The perturbations proposed in [15] can incur heavy overheads, and for this reason wires to be perturbed are chosen by utilizing IC testing principles. In [15], fault observability, as defined in SCOAP, is used as a surrogate metric for this task. The technique is evaluated using ISCAS'85 and ITC'99 benchmark circuits. For all studied circuits, the Hamming distance increased by an average of 27%, with only an average of 2.9% wire length overhead (WLO). The results for the largest and smallest studied circuit are shown in Tab. 4.

Sengupta *et al.* [32] take a different direction from other works. They utilize an information-theoretic metric to increase the resilience of the layout against proximity attacks. As demonstrated in [32], mutual information (MI) can be used to quantify the amount of information revealed by the connectivity distance between cells. Mutual information is calculated by taking into account the cells connectivity D , if

Algorithm 2: Fault Analysis-Based Swapping of Pins to Thwart Proximity Attack (Adapted from [8]).

Input: Partitions

Output: List of target and swapping pins

```

1 ListofTargetPins =  $\emptyset$ ;
2 ListofSwappingPins =  $\emptyset$ ;
3 ListofUntouchedPins = All partition pins and I/O
  ports;
4 while Untouched output partitions pins or input ports
  exist do
5   for UntouchedPin do
6     SwappingPins =
7     BuildSwappingPinsList(UntouchedPin); for
8     SwappingPin  $\in$  SwappingPins do
9       Compute
10      TestMetric(UntouchedPin, SwappingPin);
11 Find the TargetPin and SwappingPin with the
12 Highest TestMetric from its SwappingPins;
13 ListofTargetPins+ = TargetPins;
14 ListofSwappingPins+ = SwappingPins;
15 ListofUntouchedPins- = TargetPins;
16 ListofUntouchedPins- = SwappingPin;
17 Swap TargetPin and SwappingPin;
18 Update netlist;
19 Return: ListofTargetPins and ListofswappingPins;
20 BuildSwappingPinList(TargetPin);
21 Input: TargetPin $P_{x,i,out}$ 
22 Output: SwappingPins for TargetPin
23 for PinJ  $\in$  SwappingPins do
24   if CombinationalLoop(TargetPin, PinJ) then
25     SwappingPins- = PinJ;
26 Return: SwappingPins;
```

they are connected or not, and their Manhattan distance X , described by equation 2, where $H[\cdot]$ is the entropy. The distribution of the variables X for a given layout is determined pair-wise for all gates, allowing a straightforward computation of $I(X; D)$. Thus, layouts with the lowest mutual information, i.e., the correlation between cell connectivity and their distance is low, are more resilient against proximity attacks.

In order to minimize the information “leaked” from mutual information, [32] applies cell placement randomization and three other techniques: g-color, g-type1, and g-type2. Randomizing the cell placement can achieve the desired low mutual information, however, the PPA overhead incurred is excessive. Minimizing mutual information without excessive PPA overhead can be achieved by the other techniques. From a graph representation of the circuit, graph coloring can be used to hide connectivity information, where gates of the same color must not be connected. Thus, the resulting colored netlist is then partitioned by clustering all cells of same color

together. During cell placement, the cells with the same color will be confined within their respective clusters. According to [32], these constraints naturally mitigate the information leakage to a great extent. The technique g-color utilizes only the graph coloring as described above. The other two, g-type1 and g-type2, take into account the type of the gate to create the clusters. The g-type1 approach clusters gates only by their functionality, while g-type2 utilizes functionality and the number of inputs for clustering. The authors assessed their techniques utilizing ISCAS'85 and MNCN benchmark suites. Results for the smallest and largest circuits are shown in Tab. 4.

$$MI = I(X; D) = H[X] - H[X/D] \quad (2)$$

Similar to the pin swapping technique proposed by [8], Wang *et al.* [19] propose a placement-based defense with the same objective of deceiving a proximity attack by perturbing the proximity information. Differently from pin swapping, their placement-based defense considers the incurred wire-length overhead as a metric. This technique is based on changing gate locations such that the proximity hint is no longer effective. Their algorithm consists of two phases, one to select which gates to be perturbed and a second phase where the selected gates are (re)placed. Gate selection is done by extracting a set of trees using two techniques, BEOL-driven and logic-aware extraction. The first approach selects all gate trees that contain any metal wires in the BEOL, i.e., connections that are not hidden from the attacker. The second approach takes into account the wire-length impact and the gate tree impact on the overall security. After extracting the set of trees, the placement perturbation is done in one of two ways: physical-driven or logic-driven. For each extracted tree, the physical-driven perturbation changes the location of gates using a Pareto optimization approach. Also, each solution is evaluated by its wire-length overhead and a perturbation metric, that discerns the placement difference from the original layout considering the security introduced. According to [19], geometric-based difference alone may be insufficient to enhance the split circuit security. Thus, a logic-driven perturbation is performed with a weighted logical difference (WLD) metric, which encourages perturbation solutions with large logical difference from its neighbors. The authors assessed their techniques combining the gate selection and perturbation as BEOL+Physical, Logic+Physical and Logic+Logic, using ISCAS'85 and ITC'99 circuit benchmarks. Results for the smallest and largest circuits considered are shown in Tab. 4.

A considerably different approach is proposed by Patnaik *et al.* [35], whereas netlist modifications are promoted (instead of placement/routing modifications during physical synthesis). The goal is to modify the netlist of a design in order to insert (partial) randomization. According to [35], it helps to retain the misleading modifications throughout any regular design flow, thereby obtaining more resilient FEOL layouts where the netlist changes are later “corrected” in the

BEOL. This methodology is implemented as an extension to commercial EDA tools with custom in-house scripts. The process goes as follows: first, the netlist is randomized. Second, the modified netlist is placed and routed. Lastly, the true functionality is restored by re-routing the BEOL. For the netlist randomization, pairs of drivers and their sinks are randomly selected and swapped. This is done in such way to avoid combinational loops that may be introduced by swapping. The modified netlist is then placed and routed, utilizing a ‘do not touch’⁵ setting for the swapped drivers/sinks to avoid logic restructuring/removal of the related nets. Finally, the true connectivity is restored in the BEOL with the help of correction cells [35] that resemble switch boxes. The technique is evaluated using ISCAS'85 circuits, and the results for the largest and smallest circuit are shown in Tab. 4.

B. WIRE LIFTING

Hiding routing information from untrusted foundries is the main objective of the Split Manufacturing technique. Since attacks mainly rely on hints left by EDA tools to recover the missing BEOL connections, the amount of hidden information is related to the circuit performance – splitting the circuits at low metal layers increase the security level. Following the same idea, wire lifting proposes ‘lifting’ wires from FEOL layer to the BEOL layer. That is, changing the routing to split metal layers has the potential to increase the security level.

Wire lifting was first presented by Imerson *et al.* [14]. In this work, Split Manufacturing is considered as a 3D IC implementation [39]. For the sake of argument, we will continue to refer to this technique as Split Manufacturing, even if the notion of untrusted FEOL vs. trusted BEOL is shifted. This type of 3D implementation consists of two or more independently manufactured ICs, where each IC represents a tier that is vertically integrated on top of each other. Connections between the tiers are done using vertical metal pillars, referred to as through-silicon vias (TSV). In [14], a 3D implementation consisting of two tiers is used for their experiments. The bottom tier containing the transistors and some routing wires (akin to the FEOL in SM), and the top tier, containing only routing wires (akin to the BEOL layer in SM). Regarding the manufacturing of these 3D ICs, the bottom tier is built in a high-end untrusted foundry, and the top tier is built in an also untrusted foundry (not necessarily high-end, however).

In [14], threat model II is used, i.e., the adversary is assumed to possess the entire netlist. The problem is formulated as the attacker being the FEOL foundry, which in turn also possesses the so called ‘unlifted netlist’ extracted from the FEOL layout. By utilizing a graph to represent the circuits as described before, the attacker seeks a bijective mapping of gates in the unlifted netlist to gates in the complete netlist. According to [14], if the attacker can distinguish

⁵This terminology is used in IC design to mean that a specific cell or family of cells should not be optimized, i.e., not to be touched.

TABLE 4: Proximity Perturbation Defense Results

Work	Attack Type	Benchmark	Defense Technique	Defense Metric	Defense Overhead	Split Layer	Result without Defense	Result with Defense
[8]	Proximity	c17	-	Hamming Distance	1 Swap for 50% HD	-*	100% CCR	78% CCR
[8]	Proximity	c7552	-	Hamming Distance	49 Swaps for 50% HD	-*	94% CCR	91% CCR
[33]	Proximity	c432	Modified Greedy Gate Swapping	EMSR	75% of WLO	-*	90% EMSR	25% EMSR
[33]	Proximity	c432	Modified Greedy Gate Swapping	EMSR	300% of WLO	-*	78% EMSR	10% EMSR
[15]	Proximity	c432	-	Hamming Distance	3.1% WLO for 46.1% HD	-*	92.4% CCR	78.8% CCR
[15]	Proximity	c432	-	Hamming Distance	4.1% WLO for 31.7% HD	-*	62.8% CCR	37.9% CCR
[32]	Proximity	c432	Random	Mutual Information	< 10% PPA	M1	17% CCR	< 1% CCR
[32]	Proximity	c432	g-color	Mutual Information	< 10% PPA	M1	17% CCR	2% CCR
[32]	Proximity	c432	g-type1	Mutual Information	< 10% PPA	M1	17% CCR	6% CCR
[32]	Proximity	c432	g-type2	Mutual Information	< 10% PPA	M1	17% CCR	4.5% CCR
[32]	Proximity	c7552	Random	Mutual Information	< 10% PPA	M1	13% CCR	< 1% CCR
[32]	Proximity	c7552	g-color	Mutual Information	< 10% PPA	M1	13% CCR	2% CCR
[32]	Proximity	c7552	g-type1	Mutual Information	< 10% PPA	M1	13% CCR	4% CCR
[32]	Proximity	c7552	g-type2	Mutual Information	< 10% PPA	M1	13% CCR	3% CCR
[19]	SAT	c432	BEOL+Physical	Perturbation	4.5% WLO	-*	58% CCR	56% CCR
[19]	SAT	c432	Logic+Physical	Perturbation	5.57% WLO	-*	58% CCR	58% CCR
[19]	SAT	c432	Logic+Logic	WLD	1.68% WLO	-*	58% CCR	52% CCR
[19]	SAT	b18	BEOL+Physical	Perturbation	8.06% WLO	-*	15% CCR	14% CCR
[19]	SAT	b18	Logic+Physical	Perturbation	1.70% WLO	-*	15% CCR	17% CCR
[19]	SAT	b18	Logic+Logic	WLD	0.61% WLO	-*	15% CCR	16% CCR
[35]	Proximity	c432	Netlist Randomization	Hamming Distance	< 10% PPA overall	-*	92.4% CCR	94.3% CCR
[35]	Proximity	c7552	Netlist Randomization	Hamming Distance	< 10% PPA overall	-*	94.4% CCR	94.3% CCR

* Split layer not specified by the authors.

any gate between the two netlists, the split circuit does not provide any security. A security notion is discussed by the authors, based on existing multiples mapping between gates in the unlifted and the complete netlist. Called k -security, this metric qualifies that gates across the design are indistinguishable from at least $k - 1$ other gates in the circuits. Thus, a defender wants to lift wires in a way to guarantee the higher k - security possible. Two procedures are proposed to achieve this goal, one utilizing a greedy heuristic targeted at small circuits (due to scalability issues), and another procedure that utilizes partitioning to solve those issues. For their experimental study, they have utilized the ISCAS'85 benchmark suite and a DES crypto circuit with approximated 35000 gates. The results are shown in Tab. 5, where $k = 1$ is the original circuit and $k = 48$ is when all the wires are lifted. It is worth to mention that, besides the notion of the security metric, their defense technique was not validated using an actual proximity attack towards the modified netlist.

An artificial routing blockage⁶ insertion that promotes wire lifting is proposed by Magaña *et al.* [18]. The goal of this technique is to deceive proximity attacks by wire lifting. As discussed before, the objective of commercial EDA tools

⁶This terminology is used in IC design to mean that a specific area should be avoided by the EDA tool for a specific task. A blockage can be for placement and/or for routing.

is to guarantee the best PPA possible. During the routing stage, lower metals are preferred for signal routing, promoting better PPA. Thus, routing blockages can be inserted at the split layer (usually the lowest possible), forcing signals to be routed above the split layer. The result is an artificial wire lifting done during the routing stage.

Applying this type of procedure must be done considering the design routability and overhead introduced, as well as top level floorplan decisions for the power grid, clock distribution, and resources for busses. Larger designs are generally difficult to be routed – simply reducing the number of routing layers can make the design unroutable. In [18], a procedure is proposed to insert routing blockages ensuring the design routability is kept. After a first routing stage, the design is divided into small rectangular non-overlapping windows. The routing congestion then is analyzed in each window at the split layer for the blockage insertion. If the area has capacity for more routing, a routing blockage is inserted, otherwise the original routing is kept. Utilizing ISPD'11 circuits, the technique is evaluated using the proximity attack proposed by [18], and its effectiveness using two metrics, $E[LS]$ and FOM . The metric $E[LS]$ reports the candidate list size, being an average over different search areas. The metric FOM is a figure of merit of the ratio of candidates list size divided by the search area, when averaged over all the search areas at the split layer. According to [18], higher value of FOM means it is more challenging for the attacker

TABLE 5: Wire Lifting Defense Results

Work	Attack Type	Benchmark	Defense Technique	Defense Metric	Defense Overhead	Split Layer	Result without Defense	Result with Defense
[14]	SAT	c432	Wire Lifting	k -security	477% of WLO	-*	k=1	k=48
[18]	Proximity	Superblue 1	Routing Blockage Insertion	$E[LS]$	Not Presented	M4	1.51	1.77
[18]	Proximity	Superblue 1	Routing Blockage Insertion	FOM	Not Presented	M4	1222.8	1433
[34]	Proximity	c432	Concerted Lifting	Hamming Distance	7.7% of Area	Average**	23.4	45.9
[34]	Proximity	c432	Concerted Lifting	CCR	13.2% of Power	Average**	92.4	0
[34]	Proximity	c7552	Concerted Lifting	Hamming Distance	16.7% of Area	Average**	1.6	25.7
[34]	Proximity	c7552	Concerted Lifting	CCR	9.3% of Power	Average**	97.8	0
[31]	Proximity	c2670	CMP-Friendly	Hamming Distance	3.4% of WLO	-*	14.5%	20.4%
[31]	Proximity	c2670	CMP-Friendly	CCR(%)	3.4% of WLO	-*	48.1%	33.4%
[31]	Proximity	b18	CMP-Friendly	Hamming Distance	0.4% of WLO	-*	21.6%	27.6%
[31]	Proximity	b18	CMP-Friendly	CCR(%)	0.4% of WLO	-*	12.1%	10.7%
[31]	Proximity	c2670	SADP-Compliant	Hamming Distance	7.49% of WLO	-*	14.5%	24.4%
[31]	Proximity	c2670	SADP-Compliant	CCR(%)	7.49% of WLO	-*	48.1%	6.4%
[31]	Proximity	b18	SADP-Compliant	Hamming Distance	4.64% of WLO	-*	21.6%	29.6%
[31]	Proximity	b18	SADP-Compliant	CCR(%)	4.64% of WLO	-*	12.1%	2.7%
[30]	Proximity	s526	Net Partitioning	CCR(%)	Not Presented	-*	40%***	0%***
[30]	Proximity	s526	Net Partitioning & Cell Hiding	CCR(%)	Not Presented	-*	40%***	0%***
[30]	Proximity	s526	Net Partitioning & Cell Hiding & Pin Shaking	CCR(%)	Not Presented	-*	40%***	0%***
[30]	Proximity	s9234.1	Net Partitioning	CCR(%)	Not Presented	-*	30%***	4%***
[30]	Proximity	s9234.1	Net Partitioning & Cell Hiding	CCR(%)	Not Presented	-*	30%***	1.5%***
[30]	Proximity	s9234.1	Net Partitioning & Cell Hiding & Pin Shaking	CCR(%)	Not Presented	-*	30%***	1.5%***

* Split layer not specified by the authors.

** Results are given as an average between M3, M4 and M5.

*** These results cannot be compared with previous ones as the transistor technology is vastly different.

because of the density of candidates (over the same search area). The results for the *Superblue 1* circuit is shown in Tab. 5.

Design for Manufacturability (DFM) has become an extremely important aspect of IC design for many years now. Manufacturing an IC is a sensitive process that involves many critical steps. Hence, a layout is required to be compliant to several rules to ensure its manufacturability. A layout is said to be manufacturable if there are no DRC violations. However, for a design to also achieve high yield, the layout must also pass strict DFM checks. The most common checks are related to wire and via density over predetermined region sizes. Until now, defense techniques discussed were mainly concerned about security and PPA overheads. Feng *et al.* [31] argue that previous works have largely neglected manufacturability concerns. Therefore, they proposed two wire-lifting techniques that address two important DFM-related techniques: Chemical Mechanical Planarization (CMP) and Self-Aligned Double Patterning (SADP) [40]. The first technique, CMP-friendly routing defense is divided into layer elevation, wire selection, and re-routing. Layer elevation selects wires for lifting according to following principles [31]:

- The wire has a significant logic difference from its neighboring wires. As such, an incorrect connection in attacking this wire may lead to more signal differences.
- The wire has large observability such that an erroneous

guess by the adversary can easily affect the circuit primary output signals.

- The wire segment is originally at a wire-dense region. The wire density of this region would be reduced by the layer elevation and makes the corresponding FEOL layer have more uniform wire density.
- The BEOL region where the wire is elevated to has low wire density so that the density of the corresponding BEOL layer is more uniform.

Principles 1 and 2 have the intention to increase security in the same way as described in [15]. After the wire lifting step, a set of wires is selected for re-routing. The selection has two purposes, CMP-friendliness and security improvement. For CMP-friendliness, wires located in dense regions are selected to be re-routed in sparse areas. For the security improvement, decoys are inserted if the routing detour passes through a sparse area. An attacker would feel suspicious and may realize that the detour is a defense measure. After selecting the set of wires to be re-routed, wires are re-routed one at a time. According to [15], their routing approach considers wire density, while the routing perturbation proposed by [15] can be solely focused on security, and may not be CMP-friendly. Utilizing a graph representation, their re-routing method is based on the Dijkstra's shortest path algorithm [41] where the density of wires is used as a metric.

With a few exceptions, the SADP-compliant routing de-

fense follows the same approach as described above. During wire lifting, the density is not considered. Wire re-routing is actually wire extension of FEOL wires as in [42]. This wire extension of FEOL wires inevitably leads to re-routing of connected BEOL wires. According to [31], solving SADP violations by wire extension can also increase security, as it increases the distance between vias. The wire extension for simultaneous SADP-compliance and security is realized using Integer Linear Programming. In their experiments, ISCAS'85 and ISPD'11 are used to evaluate their techniques. Each technique, CMP-friendly and SADP-compliant, is evaluated separately. The results for the smallest and largest circuit are shown in Tab. 5.

Wire lifting approaches, in general, are not cost-free. As shown in the previous results, wire-lifting based defenses introduce a considerable PPA overhead. The cost-security trade-offs were first studied by Paitinak *et al.* [34], i.e., PPA margins for a given security budget. In [34], a concerted wire-lifting method is proposed. The authors claim to enable higher degrees of security while being cost-effective. For their method, custom elevating cells are used for executing the wire-lifting. Elevating cells connect gates or short wires directly to the first layer above the split layer. Their wire-lifting method utilizes three strategies: lifting high-fanout nets, controlling the distance for open pin pairs, and obfuscation of short nets. High-fanout nets are chosen to be lifted for two reasons: (a) a wrong connection made by the attacker propagates the error to multiple locations, and, (b) introduces multiple open pin pairs. As the attack to overcome is the proximity, controlling the open pin pairs distance is necessary. This distance is controlled at will simply by controlling the placement of the elevating cells. According to [34], short nets may be easy for an attacker to identify and localize (from assessing driving strengths). Short wires are obfuscated by inserting an elevating cell with two pins close to each other, one being the true connection and the other a dummy connection. Finally, wires are lifted according to those strategies until a given PPA budget is reached. For their experimental study, ISCAS'85 and ISPD'11 circuits are utilized. However, results for attacks are presented only for ISCAS'85 circuits. For ISPD'11, only the PPA impact result introduced by their technique is presented. Once again, we present the results for the smallest and largest of the studied circuits in Tab. 5.

While the majority of studies reported in our survey make use of conventional transistors (bulk CMOS technologies with either planar or FinFET transistors), Yang *et al.* [30] proposed a design methodology to secure Split Manufacturing for Vertical Slit Field Effect Transistor (VeSFET)-based integrated circuits. VeSFET is a twin-gate device with a horizontal channel and four metal pillars implementing vertical terminals [43]. While a detailed explanation on VeSFETs is beyond the scope of this work, we do highlight the differences between VeSFET and conventional transistors. In contrast with conventional transistors, VeSFET can be accessed by both top and bottom pillars, allowing two-side

routing and offering a friendly monolithic 3D integration [43]–[45]. While the MOSFET has two layers, FEOL and BEOL, VeSFET has tiers of the layer containing the transistors. Connections between tiers can be made directly, same as TSV by the pillars, or by a layer containing connections between tiers. A VeSFET 2D IC design contains only one tier and both top and bottom connections, whereas 3D IC design contains two or more tiers. In summary, the notion of tier is pushed down to the transistor level in this device topology, thus making it an interesting platform for Split Manufacturing.

The method proposed by [30] assumes that both foundries are untrusted and have the same capability (i.e., same technology). For 2D IC designs, the first foundry manufactures the tier with the top connections, comprising most of the connections. Then, the rest of the bottom connections, comprising of the critical minority connections, are completed by the second foundry. For 3D IC designs, they proposed a special type of standard cell referred as cell A and B. Cell A has two tiers that are visible and manufactured by the first foundry, with inter-tier connections. Cell B has only the top tier visible and manufactured by the first foundry, the low tier is completed by the second foundry, without inter-tier connections. Thus, transistors can be hidden from the first foundry as a security feature. Vulnerabilities claimed by [30] for both 2D and 3D methods are described in Tab. 6. Note, reverse engineering and IC overbuilding is claimed to be impossible because the first foundry controls the number of wafers available to the second foundry.

Increasing the security of both 2D and 3D VeSFET designs is achieved by net partitioning, and exclusively for 3D designs, by transistor hiding and pin shacking. Net partitioning is performed similarly to the wire lifting techniques described above, where nets are chosen to be routed in the bottom connection layer, thus, hiding those from the first foundry. Their selection method is done by selecting nets from sequential logic. First, all the high-fanout nets are selected to be partitioned. Next, the remaining nets are selected by a search area, where two approaches are used, distance-first search and high-fanout first search. In distance-first method, a pin in a predefined search window connecting to an un-partitioned net is selected when it has the minimum distance to the currently processed pin pair. The FO-first search method selects the pin connecting to a net having the highest FO in the searching window. Transistor hiding in 3D designs is done by utilizing cells similar to the cell B. Cells connected only by partitioned nets are candidates for hiding. After selecting the candidates, availability of unused transistors accessible for the second foundry in the lower tiers of the nearby cells is checked. If the available transistor count is sufficient, then the cell is hidden. The empty space created could provide clues for the first foundry about the security technique. Pin shacking is applied, obfuscating the empty space. Some nearby cells are moved to this area to obfuscate the layout for any distance-based proximity attackers. In [30], 10 MCNC LGSynth'91 benchmark circuits are used to

evaluate the effectiveness of their methodology. The best and worst results are shown in Tab. 5. It is worth to mention that, even though the VesFET implementation mimics the conventional Split Manufacturing implementation, the results cannot be compared side by side in a fair manner.

TABLE 6: Split Manufacturing VesFET Method Vulnerabilities Described by [30]

Threats	1st Foundry	2nd Foundry
Design Reconstruction	2D IC: Very Difficult 3D IC: Impossible	Impossible due to a very limited information
Trojan Insertion	Possible, but will be detected	No control of devices
Reverse Engineering	Meaningless	Impossible
IC Overbuilding	Meaningless	

C. LAYOUT OBFUSCATION

The main goal of Split Manufacturing – to hide sensitive information from untrusted foundries – is compromised once we start to consider more regular structures such as memory. Even without knowing where all the routing goes to, an attacker can easily identify regular structures just by looking at the FEOL layout, possibly leading to easier attacks. Mitigating attacks towards regular structures could be done by obfuscating those structures in such a way that they became indistinguishable. In this section, we discuss works that propose layout obfuscation techniques to be used in a Split Manufacturing context.

During the development of a modern IC, third-party IPs are sought to close a technological gap or to minimize time-to-market. IPs are typically categorized as soft and hard IPs: soft IPs typically come in code form, giving the customer flexibility to modify the IP such that it meets a given specification during synthesis. Therefore, soft IPs do not present a direct challenge for a Split Manufacturing design flow. Perhaps, and on a very specific scenario, a given IP can facilitate a proximity attack because it promotes certain library composition choices over others.

On the other hand, hard IPs are completely designed by the vendor and are technology dependent. In some instances, the vendor only provides an abstract of the IP; the customer then has to rely on the foundry to replace the abstract by the actual layout. Thus, splitting a hard IP is not trivial. Additional information is needed to be provided by the vendor, which is not guaranteed, making the IP completely incompatible with Split Manufacturing. Even when the customer holds the entirety of the IP layout, differences between the FEOL foundry and BEOL foundry make the IP no longer compliant with either technology and therefore virtually useless. Furthermore, defense techniques cannot be applied due to the lack of information or lack of feasibility. Hard IPs, such as embedded memories and specialized analog circuits, have been heavily optimized for maximum compactness, performance and yield. In today's IP market, there still is very little

concern with security in general, so it is not conceivable that the industry will start to provide split IP any time soon.

The security of hard IPs in a Split Manufacturing context was first analyzed by Vaidyanathan *et al.* [11]. A recognition attack flow is proposed for this purpose. An attacker holding the FEOL layer starts his attack by isolating a target embedded memory or analog hard IP. Since the targeted hard IP has a high probability to be constructed by compilation of leaf-cells, layout pattern recognition software [46] can be used for leaf-cell identification. After recognizing all the leaf-cells, the attacker attempts to infer the missing BEOL connections. Using proximity hints together with the knowledge about the regularized structure, the connections have a high likelihood to be guessed correctly. Demonstrated in [11], embedded memories, such as SRAM, are susceptible to the proposed recognition attack. Defending against recognition attacks can be achieved by means of obfuscation. According to [11], SRAM IPs can be obfuscated by the following methods:

- Randomization of periphery cells, thus avoiding predictable connections.
- Minimization of regularized topologies used for peripheral circuits such as pre-decoders, word line decoders, sense amplifiers, etc.
- Adding non-standard application-specific functions to improve obfuscation and performance.

A synthesis framework is proposed by [11] to obfuscate SRAM IPs. Referred as application-specific SRAM, it synthesizes SRAMs using augmented bitcell arrays and standard cell logic IP, instead of using leaf-cells. Such synthesis, when compared with conventional SRAM compilation, accomplishes all the three obfuscation goals described above while still providing similar performance.

Analog hard IPs are also vulnerable to recognition attacks. In contrast with embedded memories (that are often compiled), analog hard IPs are mostly hand designed to cater for a challenging specification or interface. Even when such customization degree is employed, the majority of the design is done utilizing leaf-cells (e.g., current mirrors, matched arrays, etc.). Thus, disclosing important information that could be used as leverage for recognition attacks. In [11], two methods are proposed to defend analog hard IPs against such attacks:

- Obfuscation of analog leaf-cells.
- Use of diverse topologies and architectures that enable obfuscation and efficiency.

Next, let us discuss the techniques utilized in order to achieve the goals listed above. First, adding camouflaging dummy transistors in empty spaces can turn leaf-cells indistinguishable. Second, regularizing transistor widths, which allows transistor with different channel lengths to abut each other, thereby obscuring boundaries across different sized transistors. Third, utilizing the same idea behind wire-lifting, routing blockages can be inserted between transistors below the split layer. Such routing scheme would make it difficult

to infer the missing BEOL connections, virtually in the same way as it does for a standard-cell based design.

To demonstrate the feasibility and efficacy of their proposed approaches, the authors of [11] designed and fabricated test chips in 130nm technology. For comparison, the same designs were Split Manufactured and conventionally manufactured. Split Manufacturing used Global Foundries Singapore as the trusted foundry and IBM Burlington as the trusted foundry. Conventional manufacturing was entirely done in Global Foundries Singapore. The first reported design is a smart SRAM that targets an imaging application. Two implementations of a parallel 2x2 access 1Kb SRAM were demonstrated. For conventional manufacturing, the SRAMs were traditionally implemented, and for Split Manufacturing, the SRAMs were implemented using their smart synthesis approach. For their measurements, 10 chips at 1.2V were used to demonstrate the feasibility regarding PPA. Area reported for the split manufactured samples was 75% of the conventional manufacture, and, the power consumption was 88%. Performance was equal between conventional and split manufactured, both could work with the same clock frequency.

The second demonstrated design is a DAC with statistical element selection. The test chip contains a high resolution 15-bit current steering DAC. Only a description of the results is presented, where the authors claim there are tiny measurements differences between the performance of the conventional and the split manufactured, emphasizing that the differences are within measurement noise.

An attacker trying to reverse engineering a split IC will try to recover the maximum number of connections as possible, while minimizing the Time To Evaluate (TTE), i.e., the amount of time needed to reverse engineering the IC. For Jagasivamani *et al.* [27], the goal of a designer seeking to secure its design is to create an IC with a high TTE while being cost-effective regarding design effort and PPA overheads. If TTE is high enough, an adversary would be discouraged from reverse engineering the IC. To achieve this goal, [27] proposes obfuscation methods that do not require any modifications to standard cells nor the implementation of any specialized cell.

Four techniques are proposed by [27] for layout obfuscation, (1) limited standard-cell library, (2) smart-dummy cell insertion, (3) isomorphic cell and (4) non-optimal cell placement. Along with the techniques, a set of metrics is presented to help assess the obfuscation level of a design. *Neighbor connectedness*, a measure of how interconnected cells are to their respective neighbors, i.e., how much proximity information is exposed to the attacker. For a specific cell, this metric is computed as how many connections that cell has for a given radius around it. *Standard-cell composition bias*, a metric that addresses the effort required for composition analysis of a design. The bias signature could leave information of the function of the cell. Thus, this metric measures how skewed a design is according to a specific bias cell. In [27], they utilized three types of bias cells for it, XOR-

type, flip-flop and adder type of cells. *Cell-level obfuscation*, a metric that measures the percentage of standard-cells that have been obfuscated. *Entropy*, which is similar to the concept of mutual information previously discussed.

Technique (1) aims to achieve obfuscation by reducing the usage of complex cell and instead favour only fine-grain logic to compose the design (i.e., to prefer single stage cells over complex multi-stage cells). Removing specialized complex cell could obfuscate functional signatures due to the larger granularity that is employed to construct the cell. However, since complex gates will need to be reconstructed through basic cells, a heavy PPA overhead is likely to occur when applying this technique. Technique (2) aims to obfuscate compositional analysis by adding dummy cells in such a way that a neutral bias composition is achieved. Dummy cells are inserted as spare cells⁷, focusing solely on obfuscating the composition analysis. Technique (3) obfuscates the layout by regularizing the shapes of the cells in a library. All layouts of logic standard cells are made FEOL-identical such that the overall circuit layout appears to be a sea of gates. The functionality of the cells is defined later by the BEOL connections. Thus, the true functionality of the cell is hidden at the BEOL, making cell-level identification harder. Technique (4) employs the same strategy from placement perturbation discussed before.

For their experimental study, the authors of [27] made use of a multiplier block with a high number of adder cells and a crypto-like circuit. Experiments were separated into limited library and smart dummy insertion. Results are shown as a percentage relative to the baseline circuit, i.e., without any protection approach applied. Neighbor connectedness (%) for radius $\leq 25nm$ decreased substantially for both test cases and circuits (for more information see [27]). Overheads results are shown in Tab. 7, where the results presented are normalized in relation with the baseline circuit.

TABLE 7: Performance Impacts from [27] Defenses Approaches.

Benchmark	Metric	Limited Library	Smart Dummy
mult24	Area	94.9%	72.6%
	Timing Slack	-64.8%	3.4%
a5/1	Area	69.8%	69.4%
	Timing Slack	-27.2%	-1.2%

Utilizing exactly the same concepts and metrics described in [27], Otero *et al.* [28] proposed a “trusted split-foundry toolflow” based on cellTK [47]. The concept of the cellTK-based flow is to have on-demand cell generation from a transistor-level netlist. This is heavily in contrast with a traditional ASIC flow that relies on a predefined (and thoroughly characterized) cell library. Leveraging cellTK, [28] proposed

⁷Spare cells are extra logic usually inserted during physical synthesis. These cells are used when an engineering change order (ECO) is required, such that small tweaks to the circuit logic can be performed with minimal changes to placement and routing.

an extension version referred as split-cellTK. This extension version can generate multiple physical layouts for each unique cell without modifying the circuit topology, which is then used to implement obfuscation strategies. Two strategies are proposed, referred as Uniform and Random. The Uniform strategy tries to standardize the size and spacing between cells by inserting dummy transistors to equalize the number of nMOS and pMOS devices and, after the cell placement, dummy cells are inserted in empty gaps. A Random strategy is also proposed to reduce the overhead introduced by the Uniform one. Instead of deliberately standardizing the size and spacing between cells, a specific number of empty spaces is chosen for these tasks. A more in-depth explanation about their strategies is beyond the scope of this work because they are closely related to cellTK itself. However, their goals and evaluations are the same as in [27]. For their experimental study, they utilized the island-style asynchronous FPGA developed in [48]. A test chip was Split Manufactured in 65nm and the design was synthesized with a baseline cellTK, i.e., without any defense strategy. Their defense strategies were evaluated only by simulations. The performance results for the baseline, Uniform and Random strategies when trying to obfuscate an adder are shown in Tab. 8. Trustworthiness results are given in terms of neighbor connectedness and, for all implementations discussed, neighbor connectedness results were significantly smaller than the results reported by [27].

TABLE 8: Performance Results of Obfuscating an Adder by [28].

Technique	Area (μm^2)	Power (mW)	Energy (pJ)	Perf. (MHz)
Baseline	462	0.146	0.257	568
Uniform	717	0.149	0.307	486
Random	760	0.164	0.303	542

In the context of obfuscation, but also generally for Split Manufacturing, a higher level of security is achieved when the split layer chosen is the lowest possible. Xiao *et al.* [29] point out that splitting at lower metal layer could increase the cost to manufacture the IC; it is argued that the FEOL-BEOL integration process must be more ‘precise’ for correct alignment. Thus, a closer technology match between the trusted and untrusted foundries is required. As we previously argued, if the goal is to make use of the best silicon available from an untrusted foundry, the implication is that the trusted foundry cannot be a legacy node, but perhaps can still be a mature node. In [29], a methodology for obfuscating the layout is proposed for split at M3 or higher, keeping the cost as low as possible and at the same time providing a high level of security. Their strategy is similar to the insertion of dummy cells; however, functional cells are inserted instead. Referred as obfuscated built-in self-authentication (OBISA), the inserted functional cells are connected together to form a circuit. As the circuit is connected to the original circuit it is trying to protect, they claim this fact makes it extremely

difficult for an attacker to separate the OBISA design from the original design. The idea behind OBISA is to obfuscate the layout by hindering neighbor connectedness analysis and standard-cell composition bias analysis while also perturbing the proximity between gates. As illustrated in Fig. 11, the additional functional cell could deceive proximity attacks, assuming that the EDA tool would place the gates between OBISA cells further than the original circuit.

The proposed OBISA circuitry has two operating modes: functional and authentication. During functional mode, OBISA stays idle and incoming signals and clock are gated/blocked. Thus, the original circuit is not affected by OBISA operating as it should. As the name suggests, when in authentication mode, OBISA is used to verify the trustworthiness of the manufactured IC (in the field). The specifics of the authentication are beyond the scope of this work and will not be discussed. The insertion of OBISA cells follows a similar strategy of dummy cell insertion as discussed in [27]. The connections of the inserted cells are done in certain way to promote the testability of the OBISA circuit and increase the obfuscation strength. Their approaches were evaluated using benchmark circuits from OpenCore. Results for the smallest and largest circuits are shown in Tab. 9.

TABLE 9: Implementation Results from [29]

Benchmark	Gate count	OBISA cell count	Total nets	Nets \geq M4
DES3	1559	158	1799	127
DES_perf	49517	2090	49951	1343

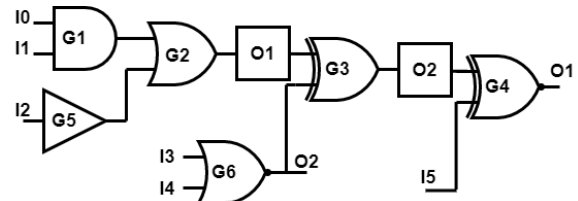

FIGURE 11: Circuit Representation with OBISA Cells (Square Cells) Inserted (adapted from [29]).

Another study using look-alike cells is reported by Masoud *et al.* [36] where the goal remains to make the attacker unable to distinguish cells and their inputs/outputs, thus mitigating attacks to some degree. In this study, two types of search algorithms are proposed to replace cells for isomorphic cells. In contrast with [27] where all cells are replaced, in [36] only cells with high impact on the security are replaced. Thus, the overhead introduced by cell replacement can be controlled without impacting the security level (i.e., a trade-off is established). The proposed algorithms are based on ‘gate normalization’, whereby truth tables of cells are analysed in order to balance the occurrence of 0s and 1s (e.g., XOR and XNOR gates are normalized by definition). An analysis is made by replacing existing gates by XORs and comparing the deviation from the the original circuit. If the

deviation is larger than a given deviation threshold, the gates are effectively replaced.

A novel layout obfuscation framework is proposed by Li et al. [49] which builds on the wire lifting concept of [14]. According to the authors, wire lifting alone is not enough to secure a design. If an attacker can tell the functionality of a specific gate that had its wires lifted, the security is already compromised. To address this problem, a framework that considers dummy cells and wire insertion simultaneously with wire lifting is proposed. As in [14], threat model II was used. The proposed framework makes use of mixed-integer linear programming (MILP) formulation for the FEOL layer generation and a Lagrangian relaxation (LR) algorithm to improve scalability. The generation of the new FEOL layout considers three operations: wire-lifting, dummy cell insertion and dummy wire insertion. Dummy wire insertion is done only on dummy cell, thus, the original functionality of the circuit is guaranteed and floating pins are avoided. Utilizing a graph representation, they re-formulate the metric security to accommodate the dummy cell and dummy wire insertion. Since the original graph isomorphic relationship is lost when new nodes are inserted, a new approach has to be used to formalize the relationship between the original and the new FEOL; this concept is denoted as k -isomorphism [50] and the associated security analysis is denoted as k -security. In their experimental study, TrustHub [51] trojan insertion methods are used to select the nodes for protection. They used ISCAS'85 benchmark circuits together with functional units (shifts, alu, and div) from the OpenSPARC T1 processor [52]. Comparison between MILP and LR algorithms are done for several k -security levels, and the results are given in terms of area overhead (AO) and wire-length overhead (WLO). The results for a few security levels are shown in Tab. 10.

TABLE 10: Comparison Between MILP and LR Algorithms for c4232 [49].

Security Level	Algorithm	AO(%)	WLO(%)
15	MILP	18	180
20	MILP	41	220
25	MILP	58	295
15	LR	18	200
20	LR	40	230
25	LR	60	305

V. FUTURE TRENDS AND CHALLENGES

Despite our effort to present the results of the many studied papers in the most fair way possible, it is clear that the hardware security community lacks a *unified benchmark suite* and/or a *common criteria* for assessing results. Often, researchers make use of benchmark suites that are popular in the test community but have no real applicability in security. For instance, the ISCAS'85 suite has no crypto cores in it, which are the bread and butter of the research in the area. Furthermore, we believe the community would largely benefit from using circuits that better represent IC design

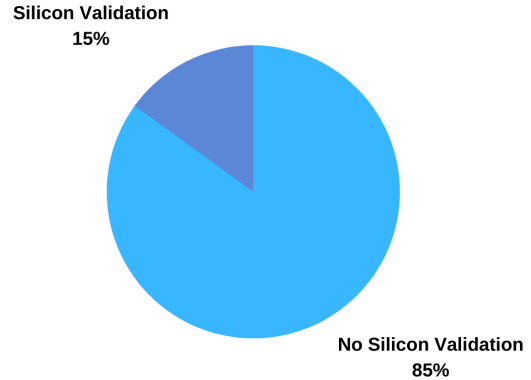

FIGURE 12: Techniques Validated in Silicon Among Presented Works.

practices of this decade where IPs often have millions of gates and ICs have billions of transistors.

While the lack of a common criteria is an issue for the academic community, the lack of an industry-supported path for Split Manufacturing is even more troubling. Today, more than ever, foundries compete for the title of ‘best silicon’ and rarely engage in cross-foundry cooperation. Efforts of the past, such as the now defunct Common Platform of IBM, Samsung and GF, could have been a catalyser for the adoption of Split Manufacturing. Without such collaboration, it is hard to foresee a future where the technique will gain traction again. Furthermore, the study of DFM-related implications of the technique is really cumbered by the fact that we cannot measure yield from massively produced Split Manufactured chips.

We have discussed in details how many attacks leverage heuristics and hints left behind by the EDA tools. Many of these heuristics are very logical and can be appreciated, even graphically, as we demonstrated in Fig. 7. It is entirely possible that machine learning approaches can detect subtle biases in the tools that are not easy to appreciate graphically. There is no consolidated knowledge of what these biases are and to which extent machine learning is effective in detecting them. This avenue of research is certainly interesting and we believe it will be the target of many papers in the near future.

Another topic that has led to no consensus is whether an attacker can make use of a partially recovered netlist. For instance, let us assume a design that instantiates the same module multiple times. If one of the modules is correctly recovered, perhaps a cursory inspection of the structure will allow the attacker to recover all other parts. The same line of thinking can be applied to datapaths and some cryptographic structures that are regular in nature. In a sense, an analysis of the functionality of the recovered netlist could be combined with existing attacks for further improvement of correctly guessed connections.

We note that many of the works studied in this survey have not actually demonstrated their approach in silicon. This fact is summarized in Fig. 12. Manufacturing a split design is ex-

tra challenge. As discussed here before, finding two foundries willing to work together could be next to impossible. This could be the main reason that such small percentage of works validated their techniques in silicon. As a community effort, we should strive to validate our approaches in silicon as often as possible.

VI. CONCLUSION

Our findings showed a big disparity on how the Split Manufacturing technique is approached among the surveyed studies. A variety of benchmark suites and metrics were used for evaluation, making direct comparisons between studies very difficult – and in some cases impossible. In spite of that, we were able to classify the studies, clearly demonstrating the many interpretations of the technique, its attacks, and defenses. Our belief is that this survey assesses the most significant studies about Split Manufacturing as we focused on papers that appear on highly-regarded venues. Results gathered from the surveyed studies were compiled such that main features, metrics, and performance results are available. Regarding the results themselves, these are presented in such manner to illustrate the present state of the technique. Therefore, this work can be very helpful for future Split Manufacturing researchers to contextualize their own techniques for augmenting Split Manufacturing.

Overall, the security of Split Manufacturing is still under debate. Some studies conclude that the technique is indeed secure, and others that it is not. However, these conclusions are reached for different scenarios, i.e., using different benchmark circuits and set of metrics. Creating a unified benchmark suite suitable for Split Manufacturing evaluation, along with a unified set of metrics to quantify/qualify its performance could facilitate the discussion about its security level. In addition, increasing the number of demonstrations in silicon could also help with evaluation and adoption issues related to Split Manufacturing.

REFERENCES

- [1] European Union Intellectual Property Office (EUIPO). 2019 Status Report On IPR Infringement.
- [2] M. Pecht and S. Tiku. Bogus: Electronic manufacturing and consumers confront a rising tide of counterfeit electronics. *IEEE Spectrum*, vol. 43, no. 5, pp. 37–46, 2006.
- [3] Ujjwal Guin, Ke Huang, Daniel Dimase, John M. Carulli, Mohammad Tehranipoor, and Yiorgos Makris. Counterfeit integrated circuits: A rising threat in the global semiconductor supply chain. *Proceedings of the IEEE*, 102(8):1207–1228, 2014.
- [4] Randy Torrance and Dick James. The state-of-the-art in semiconductor reverse engineering. *Proceedings - Design Automation Conference*, pages 333–338, 2011.
- [5] P. Subramanyan, N. Tsiskaridze, K. Pasricha, D. Reisman, A. Susnea, and S. Malik. Reverse engineering digital circuits using functional analysis. In 2013 Design, Automation Test in Europe Conference Exhibition (DATE), pages 1277–1280, March 2013.
- [6] AnySilicon. Fabless Company Sales By Region 2018. <https://any silicon.com/fabless-company-sales-by-region-2018>.
- [7] Intelligence Advanced Research Projects Activity (IARPA). Trusted Integrated Circuits Program. <https://www.iarpa.gov/index.php/research-programs/tic>.
- [8] Jeyavijayan Rajendran, Ozgur Sinanoglu, and Ramesh Karri. Is split manufacturing secure? *Design, Automation and Test in Europe (DATE)*, (Ic):1259–1264, 2013.
- [9] Kaushik Vaidyanathan, Bishnu P. Das, Ekin Sumbul, Renzhi Liu, and Larry Pileggi. Building trusted ICs using split fabrication. *IEEE International Symposium on Hardware-Oriented Security and Trust (HOST)*, pages 1–6, 2014.
- [10] T. Kikkawa and R. Joshi. Design technology co-optimization for 10 nm and beyond. In *Proceedings of the IEEE 2014 Custom Integrated Circuits Conference*, pages 1–1, Sep. 2014.
- [11] Kaushik Vaidyanathan, Renzhi Liu, Ekin Sumbul, Qiuling Zhu, Franz Franchetti, and Larry Pileggi. Efficient and secure intellectual property (IP) design with split fabrication. *IEEE International Symposium on Hardware-Oriented Security and Trust (HOST)*, pages 13–18, 2014.
- [12] B. Hill, R. Karmazin, C. T. O. Otero, J. Tse, and R. Manohar. A split-foundry asynchronous fpga. pages 1–4, Sep. 2013.
- [13] T. Usui, K. Tsumura, H. Nasu, Y. Hayashi, G. Minamihaba, H. Toyoda, H. Sawada, S. Ito, H. Miyajima, K. Watanabe, M. Shimada, A. Kojima, Y. Uozumi, and H. Shibata. High performance ultra low-k ($k=2.0/k_{eff}=2.4$)/cu dual-damascene interconnect technology with self-formed mnsixoy barrier layer for 32 nm-node. In *2006 International Interconnect Technology Conference*, pages 216–218, 2006.
- [14] Frank Imeson, Ariq Emtenan, Siddharth Garg, and Mahesh V Tripunitara. Securing Computer Hardware Using 3D Integrated Circuit (IC) Technology and Split Manufacturing for Obfuscation. *USENIX Security'13*, (Ic):495–510, 2013.
- [15] Yujie Wang, Pu Chen, Jiang Hu, and Jeyavijayan Rajendran. Routing perturbation for enhanced security in split manufacturing. *Asia and South Pacific Design Automation Conference (ASP-DAC)*, pages 605–610, 2017.
- [16] Kun Yang, Ulbert Botero, Haoting Shen, Domenic Forte, and Mark Tehranipoor. A split manufacturing approach for unclonable chipless RFIDs for pharmaceutical supply chain security. *Asian Hardware Oriented Security and Trust Symposium (AsianHOST)*, 2018-May:61–66, 2018.
- [17] S. N. Pagliarini, M. M. Isgenc, M. G. A. Martins, and L. Pileggi. Application and product-volume-specific customization of beol metal pitch. *IEEE Transactions on Very Large Scale Integration (VLSI) Systems*, 26(9):1627–1636, 2018.
- [18] Jonathon Magaña, Daohang Shi, and Azadeh Davoodi. Are proximity attacks a threat to the security of split manufacturing of integrated circuits? *IEEE/ACM International Conference on Computer-Aided Design (ICCAD)*, 07-10-Nov(c):1–7, 2016.
- [19] Yujie Wang, Pu Chen, Jiang Hu, Guofeng Li, and Jeyavijayan Rajendran. The Cat and Mouse in Split Manufacturing. *IEEE Transactions on Very Large Scale Integration (VLSI) Systems*, 26(5):805–817, 2018.
- [20] Boyu Zhang, Jonathon Crandall Magana, and Azadeh Davoodi. Analysis of Security of Split Manufacturing using Machine Learning. pages 1–6, 2018.
- [21] Suyuan Chen and Ranga Vemuri. On the Effectiveness of the Satisfiability Attack on Split Manufactured Circuits. *IEEE/IFIP International Conference on VLSI and System-on-Chip, VLSI-SoC*, 2018-Octob:83–88, 2019.
- [22] Suyuan Chen and Ranga Vemuri. Exploiting proximity information in a satisfiability based attack against split manufactured circuits. *IEEE International Symposium on Hardware Oriented Security and Trust (HOST)*, pages 171–180, 2019.
- [23] F. Brglez, D. Bryan, and K. Kozminski. Combinational profiles of sequential benchmark circuits. In *IEEE International Symposium on Circuits and Systems*, pages 1929–1934 vol.3, 1989.
- [24] Natarajan Viswanathan, C.J. Alpert, Cliff Sze, Zhuo Li, Gi-Joon Nam, and Jarrod Roy. The ispd-2011 routability-driven placement contest and benchmark suite. pages 141–146, 01 2011.
- [25] T. L. Magnanti R. K. Ahuja and J. B. Orlin. *Network Flows: Theory, Algorithms, and Applications*. Upper Saddle River, NJ, USA: Prentice-Hall, 1993.
- [26] H. Zhou, R. Jiang, and S. Kong. Cysat: Sat-based attack on cyclic logic encryptions. In 2017 IEEE/ACM International Conference on Computer-Aided Design (ICCAD), pages 49–56, 2017.
- [27] Meenatchi Jagasivamani, Peter Gadget, Michel Sika, Michael Bajura, and Michael Fritze. Split-fabrication obfuscation: Metrics and techniques. *IEEE International Symposium on Hardware-Oriented Security and Trust (HOST)*, pages 7–12, 2014.
- [28] Carlos Tadeo Ortega Otero, Jonathan Tse, Robert Karmazin, Benjamin Hill, and Rajit Manohar. Automatic obfuscated cell layout for trusted split-foundry design. *IEEE International Symposium on Hardware-Oriented Security and Trust (HOST)*, pages 56–61, 2015.
- [29] Kan Xiao, Domenic Forte, and Mark Mohammed Tehranipoor. Efficient and secure split manufacturing via obfuscated built-in self-authentication.

- Proceedings of the 2015 IEEE International Symposium on Hardware-Oriented Security and Trust, HOST 2015, pages 14–19, 2015.
- [30] Ping Lin Yang and Malgorzata Marek-Sadowska. Making split-fabrication more secure. IEEE/ACM International Conference on Computer-Aided Design, Digest of Technical Papers, ICCAD, 07-10-Nov:1–8, 2016.
- [31] Lang Feng, Yujie Wang, Jiang Hu, Wai Kei Mak, and Jeyavijayan Rajendran. Making split fabrication synergistically secure and manufacturable. IEEE/ACM International Conference on Computer-Aided Design (ICCAD), 2017-Novem:313–320, 2017.
- [32] Abhrajit Sengupta, Satwik Patnaik, Johann Knechtel, Mohammed Ashraf, Siddharth Garg, and Ozgur Sinanoglu. Rethinking split manufacturing: An information-theoretic approach with secure layout techniques. IEEE/ACM International Conference on Computer-Aided Design (ICCAD), 2017-Novem:329–336, 2017.
- [33] Zhang Chen, Pingqiang Zhou, Tsung Yi Ho, and Yier Jin. How secure is split manufacturing in preventing hardware trojan? IEEE Asian Hardware Oriented Security and Trust Symposium (AsianHOST), pages 1–6, 2017.
- [34] Satwik Patnaik, Johann Knechtel, Mohammed Ashraf, and Ozgur Sinanoglu. Concerted wire lifting: Enabling secure and cost-effective split manufacturing. Asia and South Pacific Design Automation Conference (ASP-DAC), 2018-Janua:251–258, 2018.
- [35] Satwik Patnaik, Mohammed Ashraf, Johann Knechtel, and Ozgur Sinanoglu. Raise Your Game for Split Manufacturing: Restoring the True Functionality Through BEOL. Design Automation Conference (DAC), pages 1–6, 2018.
- [36] Mohamad A. Masoud, Youssa Alkabani, and M. Watheq El-Kharashi. Obfuscation of Digital Systems using Isomorphic Cells and Split Fabrication. International Conference on Computer Engineering and Systems (ICCES), pages 488–493, 2019.
- [37] Meng Li, Bei Yu, Yibo Lin, Xiaoqing Xu, Wuxi Li, and David Z. Pan. A Practical Split Manufacturing Framework for Trojan Prevention via Simultaneous Wire Lifting and Cell Insertion. IEEE Transactions on Computer-Aided Design of Integrated Circuits and Systems, 38(9):1585–1598, sep 2019.
- [38] M. Bushnell and Vishwani Agrawal. Essentials of Electronic Testing for Digital, Memory and Mixed-Signal VLSI Circuits. Springer Publishing Company, Incorporated, 2013.
- [39] Tezzaron Semiconductors. 3D-ICs and Integrated Circuit Security. Tech. rep. 2008.
- [40] D. Z. Pan, B. Yu, and J. Gao. Design for manufacturing with emerging nanolithography. IEEE Transactions on Computer-Aided Design of Integrated Circuits and Systems, 32(10):1453–1472, 2013.
- [41] N. Jasika, N. Alispahic, A. Elma, K. Ilvana, L. Elma, and N. Nosovic. Dijkstra's shortest path algorithm serial and parallel execution performance analysis. In 2012 Proceedings of the 35th International Convention MIPRO, pages 1811–1815, 2012.
- [42] Y. Ding, C. Chu, and Wai-Kei Mak. Throughput optimization for sadp and e-beam based manufacturing of 1d layout. In 2014 51st ACM/EDAC/IEEE Design Automation Conference (DAC), pages 1–6, 2014.
- [43] W. Maly, N. Singh, Z. Chen, N. Shen, X. Li, A. Pfitzner, D. Kasprovicz, W. Kuzmicz, Y. Lin, and M. Marek-Sadowska. Twin gate, vertical slit fet (vesfet) for highly periodic layout and 3d integration. In Proceedings of the 18th International Conference Mixed Design of Integrated Circuits and Systems - MIXDES 2011, pages 145–150, 2011.
- [44] M. Weis, A. Pfitzner, D. Kasprovicz, R. Emling, T. Fischer, S. Henzler, W. Maly, and D. Schmitt-Landsiedel. Stacked 3-dimensional 6t sram cell with independent double gate transistors. In 2009 IEEE International Conference on IC Design and Technology, pages 169–172, 2009.
- [45] X. Qiu and M. Marek-Sadowska. Can pin access limit the footprint scaling? In DAC Design Automation Conference 2012, pages 1100–1106, 2012.
- [46] M. Schobert et al. Degate. <http://www.degate.org/documentation>.
- [47] R. Karmazin et al. celltk: Automated layout for asynchronous circuits with nonstandard cells. IEEE ASYNC, 2013.
- [48] B. Hill et al. A split-foundry asynchronous fpga. IEEE CICC, 2013.
- [49] Haocheng Li, Satwik Patnaik, Abhrajit Sengupta, Haoyu Yang, Johann Knechtel, Bei Yu, Evangeline F.Y. Young, and Ozgur Sinanoglu. Attacking split manufacturing from a deep learning perspective. Design Automation Conference, pages 1–6, 2019.
- [50] James Cheng, Ada Fu, and Jia Liu. K-isomorphism: Privacy preserving network publication against structural attacks. pages 459–470, 01 2010.
- [51] H. Salmani, M. Tehranipoor, and R. Karri. On design vulnerability analysis and trust benchmarks development. In 2013 IEEE 31st International Conference on Computer Design (ICCD), pages 471–474, 2013.
- [52] P. Nguyen, T. Tran, P. Diep, and D. Le. A low-power asic implementation of multi-core opensparc t1 processor on 90nm cmos process. In 2018 IEEE 12th International Symposium on Embedded Multicore/Many-core Systems-on-Chip (MCSoc), pages 95–100, 2018.



TIAGO D. PEREZ received the M.S. degree in electric engineering from the University of Campinas, São Paulo, Brazil, in 2019. He is currently pursuing a Ph.D. degree at Tallinn University of Technology (TalTech), Tallinn, Estonia.

From 2014 to 2019, he was a Digital Designer Engineer with Eldorado Research Institute, São Paulo, Brazil. His fields of work include digital signal processing, telecommunication systems and IC implementation. His current research interests

includes the study of hardware security from the point of view of digital circuit design and IC implementation.



SAMUEL PAGLIARINI (M'14) received the PhD degree from Telecom ParisTech, Paris, France, in 2013.

He has held research positions with the University of Bristol, Bristol, UK, and with Carnegie Mellon University, Pittsburgh, PA, USA. He is currently a Professor of Hardware Security with Tallinn University of Technology (TalTech) in Tallinn, Estonia where he leads the Centre for Hardware Security. His current research interests

include many facets of digital circuit design, with a focus on circuit reliability, dependability, and hardware trustworthiness.

...