

# Everlasting Secure Key Agreement with performance beyond QKD in a Quantum Computational Hybrid security model

Nilesh Vyas and Romain Alléaume  
Télécom Paris, LTCI, Institut Polytechnique de Paris,  
19 Place Marguerite Perey, 91120 Palaiseau, France

Extending the functionality and overcoming the performance limitation under which QKD can operate requires either quantum repeaters or new security models. Investigating the latter option, we introduce the *Quantum Computational Hybrid* (QCH) security model, where we assume that computationally secure encryption may only be broken after time much longer than the coherence time of available quantum memories. We propose an explicit  $d$ -dimensional key distribution protocol, that we call MUB-*Quantum Computational Timelock* (MUB-QCT) where one bit is encoded on a qudit state chosen among  $d + 1$  mutually unbiased bases (MUBs). Short-term-secure encryption is used to share the basis information with legitimate users while keeping it unknown from Eve until after her quantum memory decoheres. This allows reducing Eve’s optimal attack to an immediate measurement followed by post-measurement decoding.

We demonstrate that MUB-QCT enables everlasting secure key distribution with input states containing up to  $O(\sqrt{d})$  photons. This leads to a series of important improvements when compared to QKD: on the functional side, the ability to operate securely between one sender and many receivers, whose implementation can moreover be untrusted; significant performance increase, characterized by a  $O(\sqrt{d})$  multiplication of key rates and an extension by  $25km \times \log(d)$  of the attainable distance over fiber. Implementable with a large number of modes with current or near-term multimode photonics technologies, the MUB-QCT construction has the potential to provide a radical shift to the performance and practicality of quantum key distribution.

## I. INTRODUCTION

Quantum Key Distribution (QKD) enables secure key agreement with information-theoretic security. This is in contrast with classical key agreement protocols, where, security is based on computational hardness conjectures. QKD can offer *in principle* a distinctive security advantage over classical techniques, in particular in contexts where long-term security is sought.

Assessing the usefulness of QKD to serve real-world use cases *in practice* still remains a complex and disputed question. It has led to a debate that is all the more difficult to settle than different assessment perimeters that are often considered [1–4]. The difficulty of this comparison is also, to some extent, related to diverse goals that are being pursued by the researchers and engineers, who are developing QKD technology.

These goals are in particular structured around the duality between two main dimensions, namely, practicality (how to build efficient and cost-effective QKD systems) and security (how to guarantee an effective security gain with respect to existing classical techniques).

Important efforts, to make progress on both dimensions, have been invested [5]. On the practicality side, QKD systems have been developed that exhibits increased performances, and are being deployed over real-world optical networks [6–9]. On the security side, a strong and stable body of work has been evolved that establishes theoretical security for QKD [10–12]. Furthermore, the question of implementation security is being tackled with dedicated efforts [13, 14], paving a way for the certification of quantum cryptographic implementa-

tions in the near-term.

Despite this remarkable progress, further decisive advancements are however hindered. This due to the recurring issue that practicality and security aspects of QKD are, to a large extent, tackled disjointly and leads to a dilemma: on the one hand, guidelines based on cost-performance trad-off are expected to drive QKD system engineering, while on the other hand aspirations for ultimate security seem to forbid such an approach. This observation has already been voiced a decade ago, by Valerio Scarani and Christian Kurtsiefer in their “black paper on quantum cryptography” [15]. It however remains essentially unsettled today, which has a negative impact such as a slowing down QKD progress towards large-scale adoption and therefore industrialization.

We propose here an approach that aims at addressing this issue in an alternative way. It consists in leveraging on short-term computational security and noisy quantum storage to boost not only the performance and functionality but also the implementation security of quantum-based key establishment. Interestingly, while our proposed model is weaker than the unconditional security, as offered by QKD, it, however, allows us to offer *everlasting security* [16], i.e. security of key establishment against a computationally unbounded provided an initial ephemeral encrypted communication cannot be broken within a short time. As everlasting security is not achievable using computational constructions, our hybrid approach can claim a strict security gain with respect to classical techniques, in addition to extending the performance envelope.

## II. QUANTUM CRYPTOGRAPHY IN THE HYBRID SECURITY MODEL: OVERVIEW

### A. Rationale

Current QKD systems have now reached levels of performance essentially comparable to the fundamental limits on the secret capacity [17, 18]. This indicates the impressive technological maturity that quantum communications engineering has reached. Conversely, this also fundamentally limits our hope to experience large performance gains for QKD in the future.

Extending the functionality and overcoming the performance limitations of quantum-based secure communications hence requires to consider a broader picture. This can consist of pushing further the entanglement frontier, by developing our ability to send, store and process large entangled states. Such fundamental efforts will be crucial for developing large-scale quantum information processing, however, it requires some complex technological challenges to be overcome.

The approach we consider in this paper explores a complementary space: consider security models weaker than unconditional security and characterize the gain in practicality (i.e. performance and functionality, over cost). This approach requires a clear bench-marking of the security gain, with respect to classical cryptography, and the “security cost” related to the assumptions that have been introduced.

We propose in this work to explore the benefits that can be taken from assuming short-term computational security of one-way function (say AES for short.). This assumption positions our work in a space outside of unconditional security. However, we want to recall here that such an assumption is more conservative in assuming the *long-term security* of AES. This latter option is however implicitly made in the context of many QKD practical deployments [6–9], when QKD is used to renew AES encryption keys, leading to a secure communication construction that is only as secure as AES, and in which the added value of QKD is highly questionable. [1, 2, 19]

We want to claim that the direction we consider here might be a rational way out of the real-world quantum cryptography conundrum: namely to explore a space of assumptions where quantum cryptography can offer a clear security advantage over classical cryptography, namely a world in which one-way-functions would not be long-term-secure, but could still be used at short-term, to boost the performance of quantum cryptography beyond the fundamental performance bounds [17, 18], that might be too restrictive for real-world use [20].

### B. Main Results

We introduce a novel security model, **Quantum Computational Hybrid** (QCH) security model, which consists of two nested assumptions: first, it assumes that

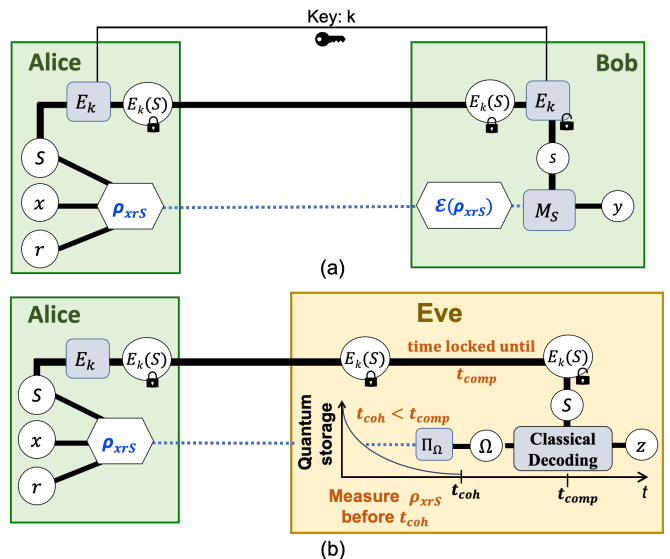

FIG. 1. A general overview of a QCT construction.

(a) Protocol between authorized Alice and Bob, defining a  $X \rightarrow Y$  binary channel.

(b) Protocol between authorized Alice and Eve, defining a  $X \rightarrow Z$  binary channel. Technologically limited Eve (due to QCH security model) cannot break time-locked encryption before  $t_{comp}$  and can only store quantum state in quantum memory during time  $t_{coh} < t_{comp}$ . As a consequence, Eve is forced to measure  $\rho_{xrs}$  before  $t_{coh}$ . At a later time, after  $t_{comp}$ , time-locked encryption elapses, and Eve learns  $S$  and performs classical decoding to obtain  $z$  as the estimate of  $x$ .

an adversary, running an efficient algorithm in polynomial time, can not break a computationally secure encryption scheme before a certain time  $t_{comp}$ , and, secondly, it assumes that any quantum memory is bound to decohere within a time  $t_{coh} < t_{comp}$ . This model could be seen as a combination of time-release encryption [21] with the noisy quantum memory model [22]. These assumptions, in particular, are well motivated by a technological assessment: as analyzed in Appendix A coherence time of the state of the art quantum memories able to store optically encoded quantum information are significantly below one second, while some generic computational one-way functions, such as AES256, are typically assumed to be secure during decades. Given the large spread, from  $\mathcal{O}(1)$  and  $\mathcal{O}(10^9)$  s, between the upper bound for  $t_{coh}$  and lower bound for  $t_{comp}$  the validity of the QCH security model can be assumed with a very high confidence today and leaves also a very large margin for its validity in the future. An important point being that we aim at everlasting secure key distribution, for which it is sufficient to guarantee the validity of the QCH model *at the time* of protocol execution.

**Quantum Computational Timelock:** Using the QCH security model we propose a generic quantum cryptographic construction, that we call, “*Quantum Computational Time-lock*” (QCT). A *time-lock* is a part of a

locking mechanism commonly found in bank vaults and other high-security containers, designed to prevent the opening of the safe or vault until it reaches the preset time. An authorized employee of the bank can open the vault, however, any unauthorized thief or attacker trying to break in the vault cannot open it before this preset time. Combined with an extra security mechanism, such as an alarm alerting the Sheriff, the time-lock forms a very effective security mechanism. Quantum Computational Time-lock construction will essentially follow the same principle, however, in that case, a computational one-way function will play the role of the time-lock mechanism, while the decoherence (of quantum storage), plays the role of the Sheriff.

In the QCT framework authorized parties, Alice and Bob want to exchange a bit  $x$  reliably while guaranteeing that Eve, who is assumed to have a full copy of the input of the quantum channel, can only learn a negligible amount of information about  $x$ . To reach this objective, Alice and Bob, that are assumed to share a short-term secure key  $k$ , are first going to *set a computational time-lock*: they use a computational encryption scheme  $E_k$  to share a short-term-secure (but potentially large) classical secret  $S$ . The second step consists of an *encrypted quantum communication* phase, where Alice encodes the random bit  $x$  as  $\rho_{xrS}$ , where  $S$  is the time-locked secret and  $r$  is some local random string. Upon reception measures  $\mathcal{E}(\rho_{xrS})$  using operator  $M_S$ , defined by the basis  $S$ , obtaining a classical outcome,  $y$ , schematically shown in Figure 1(a).

For an unauthorized adversary Eve, the classical secret  $S$  is time-locked until time  $t_{comp}$ . As a worst-case scenario, Eve can mount her attack using a copy of the input state  $\rho_{xrS}$ . However, she cannot store quantum information during time longer than  $t_{coh} < t_{comp}$  and hence must measure state without knowing  $S$  as depicted in Figure 1(b). Her measurement  $\Pi_\Omega$  on  $\rho_{xrS}$  gives classical outcome  $\Omega$ . Later at time  $t_{comp}$ , when the time-locked encryption elapses, the secret  $S$  is supposed to be revealed to Eve, which she uses, along with the measurement outcome  $\Omega$ , to perform post-measurement classical decoding leaking to make the guess,  $z$ , on the bit  $x$ . This strategy is known as state discrimination with post-measurement information as described in [23].

**Security in QCT framework:** The principle idea to prove security in the QCT framework is to bound Eve's accessible information on the key bit  $x$ . Accessible information is a suitable post-measurement security parameter to prove security against an eavesdropper with time-limited storage [24]. This security criterion can indeed be related to the variation distance between the probability distribution of an ideal key (see section III C). It hence differs QKD, where Eve has access to a perfect quantum memory and security definition uses trace distance.

**MUB-Quantum Computational Timelock (MUB-QCT):** we also propose an explicit  $d$ -dimensional (power of 2) key agreement protocol, that we call

MUB-QCT, where one bit  $x$  is encoded on the qudit state  $|\Psi_{xr\theta}\rangle$  (of index  $x \times (d/2) + r$ , for  $r \in_R [0, d/2 - 1]$ ), in the MUB basis,  $\theta$ , chosen among the  $d + 1$  mutually unbiased bases (MUBs) in dimension  $d$ .

To prove the security of the MUB-QCT protocol, we first show that the eavesdropping reduces to performing an immediate measurement followed by post-measurement decoding. For this optimal attack strategy, the upper bound on Eve's accessible information is determined by calculating the maximum success probability or the guessing probability for Eve to retrieve the key (See section III C).

We prove that when Alice sends  $m$  copies of the encrypted qudit state, i.e.  $|\Psi_{xr\theta}\rangle^m$ , we can bound Eve's accessible information, when performing collective and non-adaptive attacks, is upper bounded by:

$$I_{acc}(X; E) \leq \mathcal{O}\left(\frac{m}{\sqrt{d}}\right) \quad (1)$$

This implies that MUB-QCT enables secure key distribution with the input state containing up to  $\mathcal{O}(\sqrt{d})$  photons when implemented in dimension  $d$ , as opposed to QKD protocols, that are limited  $\mathcal{O}(1)$  photon per channel use. This very significant improvement has important consequences on performance and functionality:

- It offers *high tolerance channel loss and to detector noise*, resulting in an important and significant performance boost w.r.t. QKD, characterized by  $\mathcal{O}(\sqrt{d})$  multiplication of key rates and an extension by  $25km \times \log(d)$  of the attainable distance over fiber.
- *MDI type security guarantee:* In MUB-QCT protocol, Eve's information is upper-bounded only by considering the state that Alice inputs. As a consequence, the implementation of Bob's measurement device is not required to be trusted, to guarantee security, i.e. we QCT enjoys some MDI-type security feature. This characteristic can be very important in the perspective of practical implementation security and enables to relax significant engineering constraints.
- It allows us to realize *multiparty key distribution* between one sender and up to  $\mathcal{O}(\sqrt{d})$  receivers, which is impossible in QKD, and could enable the development of additional network security primitives, on top of QCT.

These results illustrate the benefits of hybrid approaches to quantum cryptography, making it a promising route to extend the performance and functionality, to meet the requirements for future large-scale quantum infrastructure deployments.

TABLE I. Overview of different quantum-based key distribution protocols in high dimension. In the table,  $d$  is the dimension of the system,  $T$  is the transmittance of the channel, and  $m$  is the number of photons that are sent per channel use.

Protocol	Security Model	Secure Key Rate per channel use	Performance
QKD: $d$ dimension	Information Theoretic Sec.	$\sim T \log_2(d)$	- Less than one photon per channel use ( $m < 1$ ). - For fixed detection technology ( $p_d$ ) and $T = 10^{-L/50}$ , $L_{max} < 25 \log(1/p_d)$ .
Flood Light QKD [28, 29]	Information Theoretic Sec.	$\sim mT[1 - h_2(\frac{e^{-mT}}{2}) - \frac{Tm^2}{d} \log_2 \frac{m+d}{m}]$	- $\mathcal{O}(m)$ -fold secret key rate increase w.r.t. QKD. - no distance increase w.r.t. QKD. - Security proven for restricted attacks [28, 30].
Quantum Data Locking Discrete Variable [26]	Time-limited Q memory	$\sim T \log_2(d)$	- Security is independent of channel monitoring. - $m = 1$ (encoding on single photons).
Quantum Data Locking Continuous Variable [27]	Time-limited Q memory	Direct Reconciliation $DR = 1 + \log(T/(1-T))$ , Reverse Reconciliation $RR = 1 + \log(1/(1-T))$	- Security is independent of channel monitoring. - Constructions based on random codes.
Q. Comp. Timelock MUB-QCT [our work]	Time-limited Q memory Short-term sec. encryption	$\sim mT \log_2(\sqrt{d}/m)$	- $\mathcal{O}(\sqrt{m})$ -fold secret key rate increase w.r.t. QKD. - Security is independent of channel monitoring. - Security for collective, non-adaptive attacks

### C. Related work

Our work is in particular related to the recently proposed idea of *Quantum Enigma Machine* [25] and *Quantum data locking* [26, 27] where the security is proved by upper bound Eve's accessible information in discrete as well as continuous variable settings [24]. However, existing work on Quantum data locking systematically uses random coding arguments to build and prove the security of protocols, making the implementation so far not possible in practice.

Although further analysis is required on that matter, we conjecture that a fundamental difference between Quantum data locking (QDL) and our Quantum Computational Timelock (QCT) stems from the fact that Discrete Variable QDL constructions need to operate with a key much smaller than the channel capacity and thus much smaller than  $\log(d)$  bits. This requirement stems from the constraint of obtaining a positive data locking rate [25]. QCT, on the other hand, leverages on an additional short-term-secure encryption assumption. This enables Alice and Bob to share a secret  $S$  that is comparable to, or even possibly much larger than,  $\log(d)$  bits. This gives rise to the possibility to use strong locking schemes, such as one based on a full family of MUBs, that are moreover easy to implement with multimode coherent states, containing  $m$  photons on average. This is

precisely what we propose in this article with the MUB-QCT construction.

On the other hand Quantum Data Locking, operating in a regime where the key is much smaller than  $\log(d)$  bits requires to consider locking constructions over quantum codewords that are entangled with respect to mode partitions. This leads to constructions for which the measurement that Bob must perform, are in general entangled measurements between modes, and therefore difficult to implement in practice.

*Flood-light QKD* (FL-QKD) [28, 29]. is another recently proposed protocol. It aims at providing performance level beyond what QKD is achievable with QKD, in particular in terms of rate. FL-QKD consists in sending coherent light over a very large number of modes, while keeping mean photon number per mode below one to guarantee no-cloning. It is based on a two-way procedure, and the optical storage of a random coherent wavefront, used to perform a multimode homodyne measurement. FL-QKD could potentially allow Gbit/s secret-key rates over metropolitan-area distances. However, its current security analysis only guarantees protection against frequency-domain collective attacks and is still vulnerable to block-wise coherent attacks [30]. Moreover, while it can have a decisive impact on rate (which we also expect for QCT), FL-QKD cannot be used to extend the distance, as compared to standard QKD.

## D. Organization

We begin, in Section III, by introducing some notations and the tools required to discuss the security of the key establishment schemes we aim at constructing, namely accessible information security and post-measurement quantum state discrimination. In Section IV we provide a detailed description about the formalization of the QCH security model assumptions and argues about the validity of this model. In Section V we describe our main key establishment protocol MUB-QCT, based on the Quantum Computational Timelock framework, and where the secret  $S$  encodes for the choice of one basis out of a maximal set of  $d+1$  MUBs in dimension  $d$ . In Section VI, we analyze the performance of the functional and implementation security gain that might be obtained with MUB-QCT, when implemented over high-dimensional coherent state encodings. We also discuss experimental routes towards this objective. Finally we conclude in Section VII.

## III. PRELIMINARIES

We briefly introduce all necessary notation as well as several important concepts we will need throughout the paper.

### A. Notations

For an integer  $d$ , we use the notation  $[d] = \{0, \dots, d-1\}$ . We denote any random variable by a capital letter, for example  $X$ , distributed according to the distribution  $P_X$  over a set  $\mathcal{X}$ . The realization of a random variables  $X$  is denoted by the lower-case letters  $x$ , for  $x \in \mathcal{X}$ . For an integer  $n$ , we define any  $n$ -tuple as  $x^n := \{x_1, \dots, x_n\} \in \mathcal{X}^n$ .

We denote a Hilbert space as  $\mathcal{H}$ . A quantum state is a Hermitian operator  $\rho \in \mathcal{H}$ , satisfying  $\text{Tr}(\rho) = 1$  and  $\rho \geq 0$ . Distance between the two states is determined by the trace norm  $\|A\|_1 := \text{Tr}\sqrt{A^\dagger A}$ , for any operator  $A \in \mathcal{H}$ . We say two states  $\rho, \sigma$  are  $\epsilon$ -close if  $\frac{1}{2}\|\rho - \sigma\|_1 \leq \epsilon$ .

### B. Mutually Unbiased Bases (MUB)

**Definition 1** Let  $\mathcal{B}^{\theta_1} = \{|e_0^{\theta_1}\rangle, \dots, |e_{d-1}^{\theta_1}\rangle\}$  and  $\mathcal{B}^{\theta_2} = \{|e_0^{\theta_2}\rangle, \dots, |e_{d-1}^{\theta_2}\rangle\}$  be two orthonormal bases in a  $d$ -dimensional Hilbert space. Then,  $\theta_1$  and  $\theta_2$  are mutually unbiased if and only if

$$\forall (i, j) \in [d], \quad \left| \left\langle e_i^{\theta_1} \middle| e_j^{\theta_2} \right\rangle \right| = \frac{1}{\sqrt{d}} \quad (2)$$

In a  $d$  dimension Hilbert space, there exist at most  $(d+1)$  number of mutually unbiased bases [31]. Explicit construction of a full set of MUBs is known for prime power dimension [32] and square dimensions [33].

Throughout this article, we will assume that we can construct the full set of MUBs, denoted by  $\mathcal{B} = [d+1]$ .

### C. QCT security criterion based on accessible information

In a general QCT setting, we have two authorized parties, Alice and Bob who share an ephemeral secure key,  $k$ , such that any encryption  $E_k$  generated using this secure key  $k$  is secure or time-locked for  $t_{comp}$ . Alice and Bob are connected by a noiseless and authentic classical channel, and a quantum channel. An unauthorized Eve has full access to the input of these channel, every classical (quantum) message communicated between Alice and Bob, over the classical (quantum) channel, can be wiretapped by Eve and stored in classical (quantum) memory. However, the quantum storage is bound to decohere within time  $t_{coh} < t_{comp}$ .

Now, Alice and Bob share a classical secret  $S$  between them, using the encryption  $E_k(S)$  and the decryption  $D_k(S)$ , as shown in Figure 1(a). Following this, Alice encodes a bit  $x \in \{0, 1\}$ , using the classical secret  $S$ , on a quantum state  $\rho_{xs}$  and sends it to Bob, over the quantum channel. Bob measures the the state using a POVM  $M_Y^S$ , described by the secret  $S$ , to obtain an outcome  $y \in \{0, 1\}$ .

An adversary Eve can wiretap both  $E_k(S)$  and  $\rho_{xs}$ , and store them in classical and quantum memory, respectively. However, for Eve  $E_k(S)$  is time-locked for  $t_{comp}$ , while,  $\rho_{xs}$  fully decoheres within  $t_{coh} < t_{comp}$ . As a consequence, she is forced to measure her state before  $t_{coh}$ , using a POVM  $\hat{\Pi} := \{\hat{\Pi}_\Omega\}$ . An operator  $\hat{\Pi}_\Omega$  gives her an outcome  $\Omega$ . Finally, at time  $t_{comp}$  when time-locked encryption  $E_k(S)$  elapses, she obtains the classical secret  $S$ , which she use along with  $\Omega$  to perform post-measurement decoding to obtain a guess  $z \in \{0, 1\}$ .

Under such scenario, a security criterion requires that the joint probability distribution,  $P_{XZ}^\Pi(x, z) = P_X(x)P_{Z|X}^\Pi(z)$ , should be close to the product of its marginals  $P_X(x)P_Z^\Pi(z)$ . Where,  $P_{Z|x}^\Pi(z)$  is Eve's conditional probability to obtain  $z = x$ ,

$$P_{Z|x}^\Pi(z) = \sum_{\Omega} P_{\Omega|x}^\Pi(\Omega) \times P_{Z|\Omega S}(z) \quad (3)$$

which is the product of two events, first, the probability to obtain the measurement outcome  $\Omega$  i.e.,  $P_{\Omega|x}(\Omega) = \text{Tr}(\hat{\Pi}_\Omega \rho_{xs})$ , and second, probability to output the guess  $z$  from  $\Omega$  given  $S$ , i.e.,  $P_{Z|\Omega S}(z) = P_{Z|\Omega S}(\Omega = z = x) = \delta_{x\Omega}$ , sum over all the possible value of  $\Omega$ . Implying,

$$P_{Z|x}^\Pi(z) = \sum_{\Omega} \text{Tr}(\hat{\Pi}_\Omega \rho_{xs}) \delta_{x\Omega} \quad (4)$$

and  $P_Z^\Pi(z) = \sum_x P_X(x)P_{Z|x}^\Pi(z)$ .

This security criterion is captured by a statistical distance, i.e., the *total variation distance*, defined as

$$\Delta := \max_{\hat{\Pi}} \frac{1}{2} \sum_{x,z} |P_{XZ}^{\hat{\Pi}i} - P_X \times P_Z^{\hat{\Pi}}|. \quad (5)$$

Thus to establish the security, it is required that the variation distance  $\Delta$  should be very small.

The amount of classical information that Eve can extract from the quantum system  $\rho_{x\theta}$ , by a POVM measurement  $\hat{\Pi}$  and using post-measurement information, can be quantified by *accessible information*, defined as

$$\begin{aligned} I_{acc}(X; E) &= \max_{\hat{\Pi}} [I(X; Z)] \\ &= \max_{\hat{\Pi}} [H(X) - H(X|Z)] \\ &= H(X) - \min_{\hat{\Pi}} [H(X|Z)] \\ &\leq H(X) - H_{min}(X|Z) \end{aligned} \quad (6)$$

where, we have used the fact that  $H(\cdot) \geq H_{min}(\cdot)$  and  $H_{min}(\cdot) := -\log_2(P_{guess}(\cdot))$  is the min entropy.

The accessible information  $I_{acc}(X; E)$  is related to the total variation distance  $\Delta$  by the Alicki-Fannes' inequality [34]

$$I_{acc}(X; E) \leq 2\Delta \log |X| + \eta(2\Delta_{acc}) \quad (7)$$

where,  $\eta = -(\cdot) \log(\cdot)$ , and the Pinsker's inequality [35]

$$\Delta \leq \sqrt{\frac{1}{2} I_{acc}(X; E)} \quad (8)$$

These two inequalities imply the effectiveness of accessible information,  $I_{acc}(X; E)$ , as a valid security quantifiers. Therefore, to establish security in this setting, it is required that the accessible information  $I_{acc}(X; E)$  of Eve on random variable  $X$  should be very small. Which, in result, requires to estimate the upper bound on the maximum success probability for Eve to guess the bit correctly, as represented in Equation (6).

#### D. State discrimination with post measurement information

To calculate the maximum success probability for Eve, we will show in Section V B 1, that the above setting in QCT framework, corresponds to the problem of state discrimination with post-measurement information, as defined in [23]. According to which, the maximum success probability for Eve can be calculated for the most general strategy corresponding to the measurement using a POVM  $\hat{\Pi}$  with  $|X|^{|S|}$  outcomes, each labeled by the strings  $\Omega = (\omega_0, \dots, \omega_{|S|-1})$  i.e.,  $\{\hat{\Pi}_{\omega_0, \dots, \omega_{|S|-1}}\}$ . Where, each outcome  $\Omega$  is a string of length  $|S|$ , which equip Eve with possible outputs  $\omega_i \in \{0, 1\}$  for each  $i \in \{0, \dots, |S|-1\}$ . Later when Alice reveals the random

variable  $S$ , Eve applies following map  $f_S$  on the string  $\Omega$ , which corresponds to an output  $z = f_S(\Omega) = (\omega_s | i = s)$  i.e., the assignment is done by selecting the value  $\omega_i$  corresponding to  $i = s$ . Finally, Eve guesses the value of  $x$  from the output  $z = \omega_s$ .

The average success probability  $P_{avg}$ , with which Eve succeeds at guessing  $x$  correctly is

$$\begin{aligned} P_{avg} &= \sum_{xs} \sum_{\Omega} P_{XS}(x, s) P_{Z|X}^{\hat{\Pi}}(z) \\ &= \frac{1}{|X|} \frac{1}{|S|} \sum_{xs} \sum_{\Omega} \text{Tr}(\hat{\Pi}_{\Omega} \rho_{xs}) \delta_{x\omega_s} \\ &= \frac{1}{|X|} \frac{1}{|S|} \sum_s \sum_{\Omega} \text{Tr}(\hat{\Pi}_{\Omega} \rho_{\omega_s s}) \end{aligned} \quad (9)$$

where, the relations follows from Equation (3) and (4).

Finally the maximum success probability to guess  $x$  is then obtained by maximizing  $P_{avg}$  over POVM,

$$\begin{aligned} P_{guess} &= \max_{\hat{\Pi}} P_{avg} \\ &= \max_{\hat{\Pi}} \frac{1}{|X|} \frac{1}{|S|} \sum_s \sum_{\Omega} \text{Tr}(\hat{\Pi}_{\Omega} \rho_{\omega_s s}) \\ &= \max_{\hat{\Pi}} \frac{1}{|X|} \frac{1}{|S|} \sum_{\Omega} \text{Tr}(\hat{\Pi}_{\Omega} \sum_s \rho_{\omega_s s}) \end{aligned} \quad (10)$$

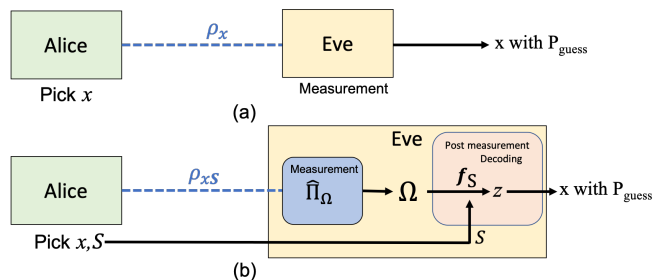

FIG. 2. (a) Standard state discrimination problem (b) Problem of state discrimination with post-measurement information as depicted in [23]

#### E. Secure key rate from classical information

As a result of the QCT framework, in the end, we are in a scenario where, Alice and Bob have access to a realization of classical random variables  $X$  and  $Y$ , respectively, whereas an adversary Eve obtains a random variable  $Z$ . Moreover, Eve has no information about  $X$  and  $Y$  other than through her knowledge of  $Z$ . This scenario is similar to a key agreement setting by a public discussion on a broadcasting channel as described in [36], where two parties Alice and Bob, are willing to share a pair of secret keys about which an adversary Eve has no information. Here, Alice and Bob are connected by

a noiseless and authentic but otherwise completely insecure public broadcasting channel. Alice and Bob share a short key ( $k$ ) required for guaranteeing authenticity and integrity of messages sent over the public channel. Every message communicated between Alice and Bob can be wiretapped by Eve, but it is assumed that Eve cannot insert fraudulent messages nor modify messages on the channel without being detected.

Under such scenario, the secret-key rate is defined as the maximal rate at which Alice and Bob can generate a secret key, such that the secret key generated is the same for Alice and Bob with very high probability and Eve has only a negligible amount of (Shannon) information about it. The lower bound on the key rate in the asymptotic limit ( $n \rightarrow \infty$ ) has been defined by Csiszár and Körner [37] as

$$\begin{aligned} K &\geq I(X;Y) - I(X;Z) = H(X|Z) - H(X|Y) \\ &\geq H_{\min}(X|Z) - H(X|Y) \end{aligned} \quad (11)$$

where,  $I(X;Y) := H(X) - H(X|Y)$  and  $I(X;Z) := H(X) - H(X|Z)$ , are the mutual information between Alice and Bob, and between Alice and Eve, respectively. General scenario and the secret key rate and other bounds on the secret key rate have been discussed in, [36], [38], and [39]. The connection of the min-entropy to the secure key rates has also been studied in [40].

#### IV. QUANTUM COMPUTATIONAL HYBRID (QCH) SECURITY MODEL

We consider a hybrid security model by combining a computational assumption, that there exist a short-term-secure computational encryption, and conversely assuming that any optical quantum memory is technologically bound to decohere within a timescale shorter than the time for which the computational encryption is secure. This new, *Quantum Computational Hybrid* (QCH) security model, is formally defined as:

1. **Short term secure encryption:** It assumes that there exist an encryption scheme  $E_k$ , such that for all message,  $m_1, m_2 \in \mathcal{M}$  ( where  $\mathcal{M}$  is the message space), and for a time,  $t$ , less than some computational time,  $t_{comp}$ , i.e.,  $t < t_{comp}$ , the following holds for an adversary running an efficient algorithm  $\mathcal{A}$ ,

$$Pr[\mathcal{A}(E_k(m_1)) = m_1] - Pr[\mathcal{A}(E_k(m_2)) = m_1] < \epsilon \quad (12)$$

Where,  $Pr[h]$  is the probability of the event  $h$ ,  $\epsilon$  is the negligible function of  $k$ . An efficient algorithm  $\mathcal{A}$  refers to any algorithm which can run in polynomial time.

2. **Time-limited quantum storage:** which assumes that a quantum memory decoheres within time  $t_{coh}$ , i.e., for input state  $\rho$ , the decoherence is defined by a complete positive trace-preserving map

(CPTP) map  $\mathcal{N}_t : \rho \rightarrow \mathcal{N}_t(\rho)$ , such that for any  $\delta \ll 1$ ,

$$\frac{1}{2} \|\mathcal{N}_{t_{coh}}(\rho) - \mathbb{I}\|_1 \leq \delta \quad (13)$$

where,  $t_{coh}$  is the coherence time of the quantum memory such that  $t_{coh} \ll t_{comp}$ , and  $\mathbb{I}$  is the identity matrix.

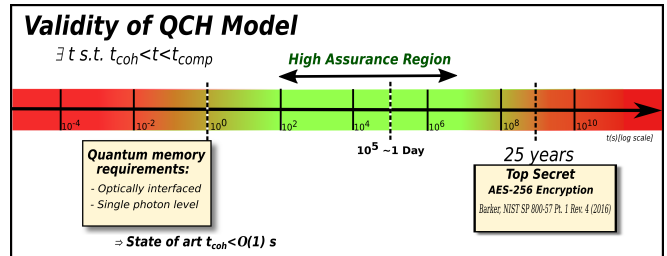

FIG. 3. Validity of QCH security model with respect to existing computational hardness assumption for AES and demonstrated quantum storage coherence time at single photon level. For example, assuming  $t_{comp} \geq 10^5$  sec, seems safe.

These assumptions of QCH model are realistic and practically motivated, yet, have never been jointly formulated and studied. Firstly, it is reasonable to make the first assumption as it only requires computational encryption to be secure for a short time, unlike classical cryptographic protocols, which assume that encryptions are difficult to break even after a very long time. For instance, *Top Secret* (AES-256 Encryption) is assumed to be secured for time of the order of  $10^9$  sec i.e.,  $\approx 30$  years [41]. Secondly, the practical implementation of an attack by an adversary on the second assumption will require efficient optical quantum storage with coherence time greater than the computational time ( $t_{coh} > t_{comp}$ ). However, among the recent experimental demonstrations of quantum memories, the coherence time is limited to a few seconds. A comparison of efficiency and coherence time of different optical quantum memory systems is shown in Table [II] (Appendix A). Thus, assuming, for example,  $t_{comp} = 10^5 s \sim 1$  day, leaves a reasonable security margin with respect to the state of art in quantum storage capabilities, as shown in Figure 3.

#### V. MUB-QCT KEY DISTRIBUTION PROTOCOL

In this section, we describe the key distribution protocol in the QCH security model, using the QCT framework. We call it the *MUB-Quantum Computational Timelock* (MUB-QCT) key distribution protocol, where the key bits are encoded onto a  $d$ -dimensional quantum state (where  $d$  is the power of 2) using full set of mutually unbiased bases (MUBs, Definition 1) as encoding bases, schematically shown in Figure 4.



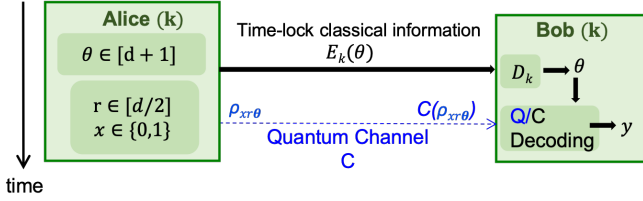

FIG. 4. Key distribution protocol between authorized party Alice and Bob. Alice time lock the classical information  $\theta$  using encryption function  $E_k$  and sends it to Bob, who decrypts it immediately to obtain  $\theta$ . Alice then encode the key  $x$  on the quantum state  $\rho_{xr\theta}$  and sends it to Bob over a quantum channel. Bob measures this state using  $(\theta)$  and obtain the measurement outcome  $y$ .

Following QCT framework, authorized parties, Alice and Bob, share some initial password or secret bits  $k$ , such that any encryption  $E_k$  generated using this password is assumed to be secure for short time  $t_{comp}$ , according to QCH security model.

In order to construct the cryptographic primitive, Alice choose the encoding basis as one of the mutually unbiased basis  $\mathcal{B}^\theta$  for  $\theta \in [d+1]$ , represented by a set of  $d$  orthogonal vectors  $\mathcal{B}^\theta = \{|e_0^\theta\rangle, \dots, |e_i^\theta\rangle, \dots, |e_{d-1}^\theta\rangle\}$ . Following which, the information  $\theta$  is time-locked as  $E_k(\theta)$  and is sent over a classical channel by Alice to Bob. On receiving, Bob decrypts it immediately using the decryption function  $D_k$  to obtain the time-locked information  $\theta$ . Finally, the bit  $x \in \{0,1\}$  is encoded on the  $i_{th}$  vector of the basis  $\mathcal{B}^\theta$  as

$$|\Psi_{xr\theta}\rangle = |e_{i_{xr}}^\theta\rangle, \text{ where, } i_{xr} = \frac{d}{2}x + r, r \in \left[\frac{d}{2}\right]. \quad (14)$$

Alice sends  $m$  copies of the qudit state,  $|\Psi_{xr\theta}\rangle^{\otimes m}$ , to Bob over a quantum channel. On receiving the qudit state Bob decodes the message by performing a measurement  $M_y^\theta$ , described by the basis  $\theta$ , and obtain an outcome  $y$ . For a given  $\theta$ , Bob's measurement operators are defined by the POVM,

$$M_0^\theta = \sum_{j \leq d/2} |e_j^\theta\rangle\langle e_j^\theta|, \text{ and, } M_1^\theta = \sum_{d/2 < j \leq d} |e_j^\theta\rangle\langle e_j^\theta|. \quad (15)$$

Bob's measurement apparatus comprises two detectors corresponding to the bit value 0 or 1. After  $n$  channel uses, the raw keys are exchanged, following which, Alice and Bob perform classical post-processing on their exchanged raw keys to transform them into a pair of secret keys.

The security of the protocol is proved by first demonstrating that under the QCH security model, the optimal attack strategy for a non-authorized party Eve consists of an immediate measurement followed by classical post-processing on measurement data using the post-measurement information. Then, for this optimal attack strategy, we prove the security by bounding Eve's accessible information, following the discussion from Section

III C. Eve's accessible information is upper bounded by estimating the upper bound on the probability to successfully guess the key bit, as shown in Equation (10).

## A. Description of Protocol

---

### MUB-QCT Protocol

---

*Parameters:*

- $n$ : channel use.
- $d$ : dimension of quantum channel between Alice and Bob. We consider a pure loss channel.
- $k$ : short key shared between Alice and Bob, to be used for computational encryption  $E_k$  which is secure for some computational time  $t_{comp}$ .
- $m$ : number of copies of quantum state per channel use.

*The protocol:*

#### 1. Local generation of $x$ and $\theta$ and $r$

- Alice chooses a  $x^n$ ,  $x_i \in \{0,1\}$ , MUBs  $\theta^n$ ,  $\theta_i \in [d+1]$  and local randomness  $r^n$ ,  $r_i \in [d/2]$  uniformly at random.
- She encrypts the bases string and the pair of subspace string as  $E_k(\theta^n)$  and sends it to Bob, who decrypts it immediately to obtain  $\theta^n$ .

#### 2. Quantum communication:

- For ( $i = 1; i \leq n; i++$ )
  - *State preparation:* Alice prepare a qudit state  $|\Psi_{x_i r_i \theta_i}\rangle$ .
  - *Distribution:* Alice sends  $m$  copies of the qudit system  $|\Psi_{x_i r_i \theta_i}\rangle^{\otimes m}$  to Bob.
  - *Measurement:* Bob measures each quantum state using a POVM,  $M_y^\theta$ , as defined in (15), with two outcomes, corresponding to the bit value, and outputs the result  $y_i$ .
- After  $n$  iterations Alice and Bob outputs: ( $A : x^n; B : y^n$ )

#### 3. Classical post-processing:

- Alice and Bob perform error correction followed by a privacy amplification, using a suitable universal<sub>2</sub> hash function [42, 43], to distill a secret key.
-



## B. Security analysis

### 1. Reduction of Eve's attack strategy in the QCT security model

If an adversary Eve tries to intercept the communication between Alice and Bob, then, to retrieve the key back she can implement two possible strategies corresponding to the problem of state discrimination with post-measurement information [23]. These strategies are

1. **Strategy S1:** *Immediate measurement on all incoming qubits followed by post-measurement decoding.*

For Eve, this strategy corresponds to perform an immediate generalized measurement,  $\hat{\Pi}_\Omega$  (see Section V B 2), on all of the incoming qubits. Stores the outcome of the measurement  $\Omega$  in a classical register. She then waits for time-lock encryption to elapse and later perform post-measurement decoding using the measurement outcome  $\Omega$  and the post-measurement information  $\theta$  to output  $z$ .

1. **Strategy S2:** *Immediate measurement on some of the incoming qubits and storing the rest in quantum memory.*

This is a strategy where Eve measures  $l$  qubits immediately upon receiving them according to strategy S1 and stores the rest of  $(n - l)$  incoming qubits in her quantum memory. Then she waits for time  $t_{comp}$  until the time-lock encryption is elapsed to obtain  $\theta$  and later performs post-measurement decoding on the immediately measured qubits and performs a projective measurement in basis  $\theta$  on the qubits stored in the memory.

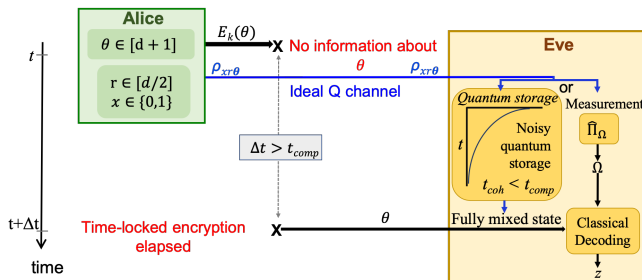

FIG. 5. An unauthorized party Eve can not break the time-lock encryption  $E_k(\theta)$ , to obtain  $\theta$ , until time  $t_{comp}$ . So when Alice sends the quantum state, Eve can either store the state in her quantum memory, with coherence time  $t_{coh}$ , or perform an immediate measurement on it. Since  $t_{coh} < t_{comp}$ , the best strategy for Eve is to perform an immediate measurement  $\hat{\Pi}_\Omega$ , obtain the measurement outcome  $\Omega$ , and later at time  $t_{comp}$ , when the time-locked encryption is elapsed, perform a post-measurement classical decoding to obtain a guess  $z$ .

**Proposition 1** *Under the assumptions of QCH security model, following holds*

$$P_{guess}(S1) > P_{guess}(S2). \quad (16)$$

where,  $P_{guess}$  is the guessing probability or the maximum success probability to retrieve the original message back. This implies that the optimal attack strategy of an adversary Eve is the strategy S1, to perform immediate measurement on all incoming qubit states and perform a post-measurement decoding at time  $t_{comp}$ .

### 2. Upper bound on Eve's accessible information

Following Section III C, to prove the security of MUB-QCT, it is required to bound Eve's accessible information. Which, consequently, require to calculate an upper bound on Eve's guessing probability to guess the key bit correctly. To calculate the guessing probability, we analyze two cases where Alice sends a single copy and multiple copies of a quantum state per channel use respectively and calculate the upper bound on the guessing probability of Eve.

- *Sending one copy of quantum state per channel use*

As shown in Section V B 1, the best strategy for an adversary is to measure all incoming qubits immediately upon receiving followed by post-measurement decoding, i.e., perform state discrimination using post-measurement information. For this strategy the best immediate measurement corresponds to a POVM ( $\hat{\Pi}_\Omega$ ), with  $2^{|\theta|}$  outcomes, as discussed in Section III C, each labeled by the  $|\theta|$  long binary strings  $\Omega = \omega_0, \dots, \omega_{|\theta|}$ , for  $\omega_\theta \in \mathcal{X} = \{0,1\}$ . Such that, when the time-locked encryption elapses and the information about the pair  $\theta$  is revealed, Eve applies the following map  $f_\theta$  on the string  $\Omega$ , which corresponds to an output  $z = f_\theta(\Omega)$ . Finally, Eve guesses the value of  $x$  from the output  $z$ . The guessing probability  $P_{guess}$ , with which Eve succeeds at guessing  $x$  correctly is calculated from Equation (10) as,

$$\begin{aligned} P_{guess} &= \max_{\hat{\Pi}_\Omega} \frac{1}{|x||\theta|} \sum_{\Omega} \text{Tr} \left( \hat{\Pi}_\Omega \sum_{\theta_r} \frac{1}{|r|} \rho_{\omega_\theta r \theta} \right) \\ &= \max_{\hat{\Pi}_\Omega} \frac{1}{|x||\theta|} \sum_{\Omega} \text{Tr} \left( \hat{\Pi}_\Omega \mathcal{F}(\Omega) \right) \\ &\leq \max_{\hat{\Pi}_\Omega} \frac{1}{|x||\theta|} \sum_{\Omega} \lambda_\Omega \text{Tr} \left( \hat{\Pi}_\Omega \right) \\ &\leq \frac{\lambda}{2(d+1)} \max_{\hat{\Pi}_\Omega} \sum_{\Omega} \text{Tr} \left( \hat{\Pi}_\Omega \right) = \frac{d\lambda}{2(d+1)} \sim \frac{\lambda}{2} \end{aligned} \quad (17)$$

Where,  $\rho_{\omega_\theta r \theta} = |e_{i_{\omega_\theta r}}^\theta\rangle \langle e_{i_{\omega_\theta r}}^\theta|$ ,  $\mathcal{F}(\Omega) = \sum_{\theta_r} \frac{1}{|r|} \rho_{\omega_\theta r \theta}$ , and  $\sum_{\Omega} \text{Tr} \left( \hat{\Pi}_\Omega \right) = \text{Tr} \sum_{\Omega} \hat{\Pi}_\Omega = \text{Tr}(\mathbb{I}_d) = d$ .  $\lambda_\Omega$  is the maximum eigenvalue of  $\mathcal{F}(\Omega)$  and  $\lambda$  is the maximum of all  $\{\lambda_\Omega\}$  for an ensemble of  $\{\mathcal{F}(\Omega)\}$ . Now the calculation for guessing probability is translated to the problem of finding the maximum eigenvalue  $\lambda$ .

To calculate  $\lambda$ , we use the the fact that for any operator  $A$ , if  $v$  is some unit eigenvector corresponding to

eigenvalue  $\gamma$ , then  $\|Av\| = |\gamma|$ , which implies  $|\gamma| \leq \|A\|$ , i.e., the maximum eigenvalue  $\lambda$  for the operator  $A$  corresponds to its norm. Similarly, for the operator  $\mathcal{F}(\Omega)$  the maximum eigenvalue corresponds to its norm. Now we have  $\mathcal{F}(\Omega)$  as the sum of  $(d+1)d/2$  rank-1 projectors  $\rho_{\omega_{\theta r \theta}}$  (the sum over  $r \in [d/2]$  and  $\theta \in [d+1]$ ). Therefore, it is now required to bound the norm of sum of  $(d+1)d/2$  rank-1 projectors. For this we use the following theorem ( which has been used and developed in [44] [45] [46])

**Theorem 1** *Following inequality holds for the sum of  $l$  rank-1 projectors acting on an arbitrary finite dimensional Hilbert space  $\mathbb{C}^d$*

$$\begin{aligned} \|O_1 + \dots + O_l\| &\leq 1 + (l-1) \cos \phi \\ \cos \phi &= \max_{i,j>1} \|O_i O_j\| \end{aligned} \quad (18)$$

Proof of Theorem 1 (Appendix D).

In our case we have  $l = (d+1)d/2$  and  $\cos \phi = \frac{1}{|r|^2 \sqrt{d}}$ , as  $|\langle e_i^{\theta_1} | e_j^{\theta_2} \rangle| = 1/\sqrt{d}$ . Following which we have

$$\begin{aligned} \lambda &\leq \|F(\Omega)\| = \left\| \sum_{\theta r} \frac{1}{|r|} \rho_{\omega_{\theta r \theta}} \right\| \\ &\leq 1 + \frac{\frac{d}{2}(d+1) - 1}{|r|^2 \sqrt{d}} \\ \lambda &\leq 1 + \frac{d(d+1) - 2}{2d^2 \sqrt{d}} \end{aligned} \quad (19)$$

Finally the guessing probability is then,

$$P_{guess} \leq \frac{\lambda}{2} \leq \frac{1}{2} + \frac{1}{\sqrt{d}} - \frac{2}{d(d+1)\sqrt{d}} \quad (20)$$

implying,

$$\left| P_{guess} - \frac{1}{2} \right| < \frac{1}{\sqrt{d}} \quad (21)$$

Thus,  $P_{guess}$  for large value of  $d$  converges to  $\frac{1}{2}$ , which is equal to classical guessing the random bit. Following which, the upper bound on Eve's accessible information from Equation (6) is

$$\begin{aligned} I_{acc}(X; E) &\leq 1 + \log_2 \left( \frac{1}{2} + \frac{1}{\sqrt{d}} \right) \\ &\leq \log_2 \left( 1 + \frac{2}{\sqrt{d}} \right) \\ &\leq \frac{1}{\ln 2} \mathcal{O} \left( \frac{2}{\sqrt{d}} \right) \end{aligned} \quad (22)$$

where, we have used the identity that  $\ln(1+x) \leq x$ . As a result,  $I_{acc}(X; E)$  for large value of  $d$  converges to 0. So, hiding information in high dimension results better security against eavesdropping.

- *Sending multiple copies of quantum state per channel use*

We now turn our focus on calculating the guessing probability for adversary when Alice send  $m$  copies of the quantum state per channel use. We consider an attack strategy for Eve, where she can store the  $m$ -copies in her quantum memory, perform any compatible measurement on all  $m$ -copies before her quantum memory decoheres i.e., within time  $t_{coh}$ , and finally when she obtain post measurement information, at time  $t_{comp}$ , perform classical post-measurement decoding. She can either measure all  $m$ -copies together, corresponding to a clooective and non-adaptive measurement or perform an adaptive measurement [47, 48], corresponding to step by step optimized measurement. For instance, in the simplest scenario she can performs an optimal measurement on the first copy use the outcome of the measurement to define the measurement on the next copy and finally the last measurement outcome decides the guess. For the security analysis with multiple copies we consider only the non adaptive attacks, corresponding to collectively measuring all  $m$ -copies immediately upon receiving.

This non-adaptive strategy is again equivalent to the problem of state discrimination using post measurement information, following which the best measurement for an adversary is to measure all the copies collectively by a POVM  $\Pi_{\Omega}$ , with  $2^{|\theta|}$  outcomes labeled by the string  $\Omega = \omega_0, \dots, \omega_{|\theta|}$ , for  $\omega_{\theta} \in \{0, 1\}$ . The guessing probability is then

$$\begin{aligned} P_{guess}(m) &= \max_{\hat{\Pi}_{\Omega}} \frac{1}{|x||\theta|^m} \sum_{\Omega} \text{Tr} \left( \hat{\Pi}_{\Omega} \sum_{\theta r} \frac{1}{|r|^m} \rho_{\omega_{\theta r \theta}}^{\otimes m} \right) \\ &= \frac{1}{|x||\theta|^m} \max_{\hat{\Pi}_{\Omega}} \sum_{\Omega} \text{Tr} \left( \hat{\Pi}_{\Omega} \mathcal{F}_m(\Omega) \right) \\ &\leq \frac{\lambda_m}{2(d+1)^m} \max_{\hat{\Pi}_{\Omega}} \sum_{\Omega} \text{Tr} \left( \hat{\Pi}_{\Omega} \right) \\ P_{guess}(m) &\leq \frac{d^m \lambda_m}{2(d+1)^m} \sim \frac{\lambda_m}{2} \end{aligned} \quad (23)$$

where,  $\mathcal{F}_m(\Omega) = \frac{1}{|r|^m} \sum_{\theta r} \rho_{\omega_{\theta r \theta}}^{\otimes m}$ , and  $\sum_{\Omega} \text{Tr} \left( \hat{\Pi}_{\Omega} \right) = d^m$ .  $\lambda_m$  is the maximum eigenvalue of all ensemble of  $\{\mathcal{F}_m(\Omega)\}$ . Now we have

$$\begin{aligned} \lambda_m &\leq \|\mathcal{F}_m(\Omega)\| = \left\| \sum_{\theta r} \frac{1}{|r|^m} \rho_{\omega_{\theta r \theta}}^{\otimes m} \right\| \\ &\leq \sum_{\theta r} \left\| \frac{1}{|r|^m} \rho_{\omega_{\theta r \theta}}^{\otimes m} \right\| \leq \sum_{\theta r} \left\| \frac{1}{|r|} \rho_{\omega_{\theta r \theta}} \right\|^m \\ &\leq \left( \left\| \sum_{\theta r} \frac{1}{|r|} \rho_{\omega_{\theta r \theta}} \right\| \right)^m \leq \lambda^m. \end{aligned} \quad (24)$$

Where, the second and the third relation follows from the Triangle inequality and Cauchy-Schwarz inequality respectively. As a result we obtain guessing probability

$$\begin{aligned} P_{guess}(m) &\leq \frac{\lambda^m}{2} \leq \frac{1}{2} \left( 1 + \frac{\frac{d}{2}(d+1) - 1}{|r|^2 \sqrt{d}} \right)^m \\ &\leq \frac{1}{2} \left( 1 + \frac{2}{\sqrt{d}} - \frac{4}{d^2 \sqrt{d}} \right)^m \end{aligned} \quad (25)$$

For large value of  $d$

$$\left| P_{guess}(m) - \frac{1}{2} \right| < \frac{m}{\sqrt{d}} + o\left(\frac{1}{\sqrt{d}}\right) \quad (26)$$

Following which, the upper bound on Eve's accessible information is

$$I_{acc}(X; E)_m \leq \log_2 \left( 1 + \frac{2m}{\sqrt{d}} \right) \quad (27)$$

$$\leq \frac{1}{\ln 2} \mathcal{O}\left(\frac{2m}{\sqrt{d}}\right). \quad (28)$$

This implies that  $m < \mathcal{O}(\sqrt{d})$  copies can be sent, while the accessible information is still negligible. For example, if  $d = 10^6$  then  $m < 10^3$  can be sent while still guaranteeing the security of the key.

**Comparison with Helstrom bound:** Interestingly, the guessing probability for state discrimination without post measurement information, corresponding to the Helstrom bound, when sending single copy of the quantum state is

$$P_{Helstrom} = \frac{1}{2} \left( 1 + \frac{\|\rho_0 - \rho_1\|_1}{2} \right) \quad (29)$$

where  $\rho_x = \frac{1}{|r||\theta|} \sum_{r\theta} \rho_{xr\theta}$ . Following which, a simple calculation gives  $\|\rho_0 - \rho_1\|_1 = 2/\sqrt{|\theta|}$ , as a result of which for full set of MUBs,

$$P_{Helstrom} = \frac{1}{2} + \frac{1}{2\sqrt{d+1}} \quad (30)$$

Implying,

$$\left| P_{Helstrom} - \frac{1}{2} \right| \leq \frac{1}{2\sqrt{d+1}} < \frac{1}{\sqrt{d}} \quad (31)$$

Similarly when sending  $m$ -copies of the quantum state  $\rho_x^{\otimes m}$ , the guessing probability corresponding to the Helstrom bound is

$$\begin{aligned} P_{Helstrom}(m) &= \frac{1}{2} \left( 1 + \frac{\|\rho_0^{\otimes m} - \rho_1^{\otimes m}\|_1}{2} \right) \\ &\leq \frac{1}{2} \left( 1 + \frac{m\|\rho_0 - \rho_1\|_1}{2} \right) \\ &\leq \frac{1}{2} + \frac{m}{2\sqrt{d+1}} \end{aligned} \quad (32)$$

Implying,

$$\left| P_{Helstrom}(m) - \frac{1}{2} \right| \leq \frac{m}{2\sqrt{d+1}} \quad (33)$$

Consequently, the expressions of guessing probability, Equation (30) and (32), for state discrimination without post measurement information are equivalent to the expression in Equation (20) and (25), for state discrimination with post-measurement information. This implies that an adversary does not gain any significant advantage by waiting for post measurement information at time  $t_{comp}$ , and is thus restricted to classical eavesdropping.

### 3. Reduction to key agreement from classical information

As a result of the strategy S1, at the end of the protocol, Eve learns a classical string  $z$ . She has no knowledge on the secret key  $s$ , other than her knowledge of  $z$ . This setting is similar to the setting for classical secret key agreement by a public discussion on a broadcasting channel as described in Section III E. Following this, the lower bound on the key rate in the asymptotic limit ( $n \rightarrow \infty$ ) is defined by Csiszár and Körner [37] as

$$K \geq I(X; Y) - I_{acc}(X; E) \quad (34)$$

Which, from Equation (6) and the relation  $I(X; Y) = H(X) - H(X|Y)$  is,

$$K \geq H_{min}(X|Z) - H(X|Y) \quad (35)$$

To decode the key bit, Bob measures in the basis  $\theta$  described by a POVM  $M_y^\theta$ , Equation (15). His measurement apparatus consists of two detectors, such that a click in each corresponds to one of the bit value i.e., 0 or 1. Now, let,  $p_c$  be the probability that there is a correct detection given that there is a click in the detector, and let,  $p_e$  be the probability that there is a wrong detection given that there is a click in the detector. Thus, we have

$$H(X|Y) = -p_c \log p_c - p_e \log p_e. \quad (36)$$

For Bob's optimal measurement, Alice and Bob will asymptotically achieve about  $H(X|Y)$  bits of common randomness, per channel use. This is the maximum amount to error-correcting information that Alice needs to transmit to Bob for each channel use.

For a lossy channel, the secret key rate per channel use is calculated as

$$\begin{aligned} K &\geq (1 - (1 - T)^m) H_{min}(X|Z) - H(X|Y) \\ &\geq (1 - (1 - T)^m) (-\log(P_{guess}(X|Z))) \\ &\quad + p_c \log p_c + p_e \log p_e. \end{aligned} \quad (37)$$

In practice, the term of the right side hand,  $H(X|Y)$  can be directly observed in a given implementation of the protocol (see Appendix (C)) and  $P_{guess}(X|Z)$  is calculated in Equation (25). Following this, the secret key rate per channel use as a function of distance is plotted in Figure (6).

## VI. ANALYSIS OF MUB-QCT PERFORMANCE ENVELOPPE

### A. Improved rate and reachable distance

We proved that when performing MUB-QCT using a  $d$ -dimensional quantum system,  $m < \sqrt{d}$  copies of a quantum state can be sent per channel use. This ability to send multiple copies has a striking consequence as it can

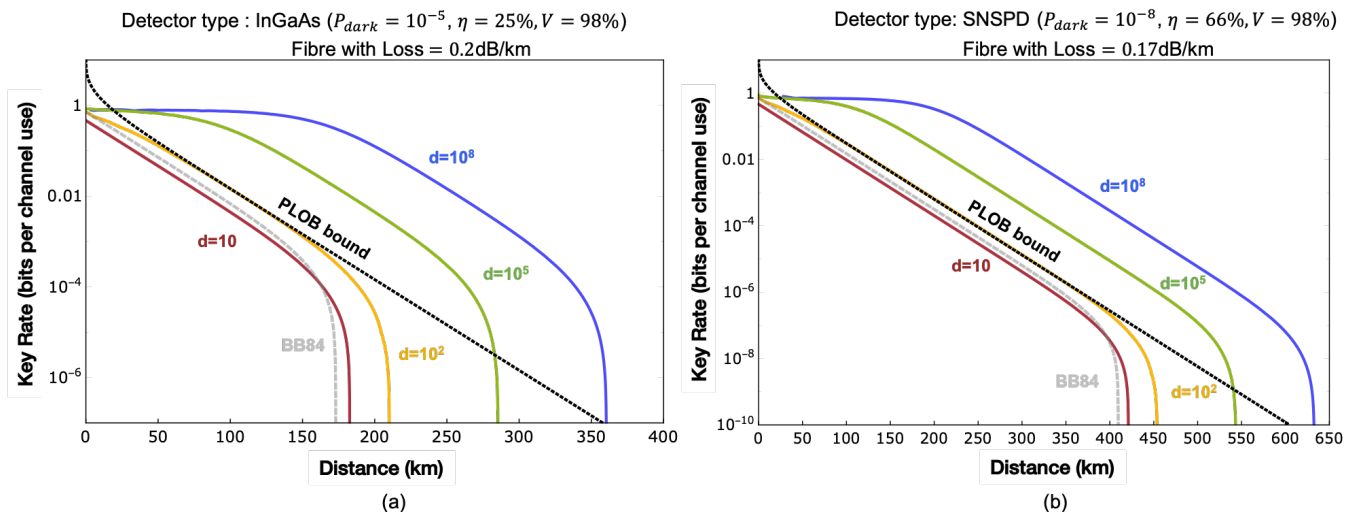

FIG. 6. Plot of key rate per channel use as a function of distance for, (a) Typical QKD Field Deployment (standard fiber, InGaAs single-photon detectors) [51] (b) Experiment in the Lab [50] (low-loss fiber, SNSPDs). The plots are given for different values of  $d$  (number of modes) and are obtained by maximizing the key rate against the mean photon number  $m$ .

offer high tolerance to the error in detection due to channel loss, resulting in an important and significant performance boost, characterized by a  $O(\sqrt{d})$  multiplication of key rates and an extension by  $25km \times \log(d)$  of the attainable distance over fiber. This is evident from the Figure (6), where the key rate (Equation (37)) is plotted for different values of  $d$  and is optimized by maximizing the key rate for different value of  $m$ . Analyzing the plots, we found that as we go to high dimensions the key rate per channel use increases. For  $d \sim 10$  the performance of the MUB-QCT is comparable to that of BB84 protocol. The performance is comparable to the single-mode PLOB bound for  $d \sim 10^2$  and for  $d > 10^2$ , there is a significant improvement in the performance.

### B. Coherent state encoding

A coherent state have photons distributed in the Poisson distribution, i.e., the probability of detecting  $n$ -photons in a coherent state is

$$P_\mu(n) = \frac{\mu^n e^{-\mu}}{n!} \quad (38)$$

Where,  $\mu = |\alpha|^2$  is the average number of photons. In the limit, where the mean photon number sent by Alice is very large, the Poisson distribution can be approximated to a Gaussian distribution with the mean of the distribution  $\mu$  and the standard deviation  $\sqrt{\mu}$ . The average number of photons that can hit the detector is then equal to the mean photon number of the coherent state. We showed that the upper bound on the number of copies of the quantum state that Alice can send, such that Eve's accessible information on the secret key is less than the mutual information between Alice and Bob is  $m < \sqrt{d}$ .

This implies that, if a coherent state with the number of photons  $\mu$ , for  $\mu + 4\sqrt{\mu} < \sqrt{d}$ , is prepared by Alice, then with very high probability (corresponding to the 4  $\sigma$  confidence, i.e., 99.994%), Eve's accessible information on the secret key can be bounded to be less than the mutual information between Alice and Bob. As a result, MUB-QCT is well suited to be implemented with continuous variables, which make use of only standard telecom components that are manageable, cheaper, much more mature from a technological point of view, and most suitable candidates for long-range quantum communication.

### C. Implementation with realistic hardware

One challenge of the MUB-QCT implementation will consist in operating the protocol with high-dimensional encodings. However, existing time or spectral encoding techniques indicate the possibility to operate with  $d$  as large of  $10^3$  and possibly  $10^5 - 10^8$  [29, 49] with existing or near-term technologies.

Possibility of achieving such a large number of modes experimentally, allows us to realize much better performance as compare to QKD, with economical and handy detectors. It makes the requirement for a very good single-photon detector optional. For example, superconducting nanowire single-photon detectors (SNSPDs), used in [50] to perform secure quantum key distribution over 421 km, which have very low dark count rates of  $10^{-8}$  and efficiency of 66%, however, are very expensive. Figure(6) illustrate that MUB-QCT would allow to obtain a very significant boost in key rates and distance, notably when operated with economical and handy detectors InGaAs [51], where reachable distance could be brought from 150 km to possibly 300 km, and possibly

rates brought to Gbit/s values over metropolitan distances.

Moreover, in MUB-QCT, the number of detectors remains constant irrespective of the dimension of the quantum system. As mentioned earlier, the measurement apparatus consists of two detectors, such that a click in each corresponds to one of the bit value i.e., 0 or 1. This is completely in contrast to the high-dimensional QKD, where, the detectors requirement scales linearly with  $d$ . The high-dimensional QKD is equivalent to performing QKD  $d$ -times in parallel for which the key rate boost is  $d$ -times that of single QKD, but comes at the cost of  $d$  expensive detectors. Furthermore, performing QKD  $d$ -times in parallel does not provide any gain in the communication distance, as the reachable distance is the same as that of a single QKD system. Thus, these notable advantage makes the implementation of MUB-QCT far more efficient and cost-effective, making it a good candidate for future quantum networks.

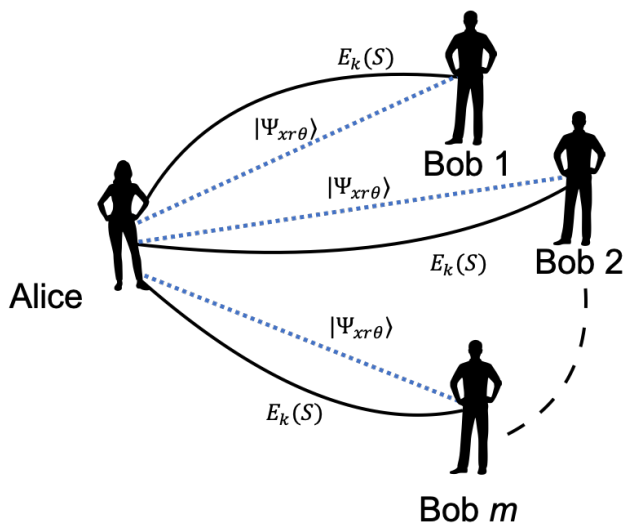

FIG. 7. Multiparty MUB-QCT:  $m$  copies of the state  $|\Psi_{xr\theta}\rangle$  generated can be sent to  $m$  authorized parties (Bob) simultaneously, allowing them to distill same key together.

#### D. Multiparty key distribution

The possibility of sending multiple copies of the quantum state per channel use can be exploited to realize multiparty key distribution in the QCH security model. In principle,  $m$  multiple copies prepared by Alice can be transmitted to at most  $m$  authorized Bobs, allowing them to distill the same key, as depicted in Figure (7). A general description of a  $m$ -party MUB-QCT distribution would consist of,

- Alice and  $m$  authorized parties exchange the classical secret (encoding bases) using a short term secure encryption.

- Alice prepares  $m$ -identical copies of a qudit state using the classical secret and send one copy to each of the  $m$ -parties.
- Each party then measures the individual state as directed by the classical secret.
- After multiple channel use, they perform information reconciliation on their strings to distill a secret key.

Its clear that in a  $d$ -dimension there can be at most  $m < \sqrt{d}$  parties. However, to enhance the performance per party the number of parties can be reduced to  $m' < m$  allowing to send on average  $m/m'$  copies of the same state per channel per party.

#### E. MDI-type security

Figure (8), presents the trust assumptions required on hardware to prove security in (a) prepare and measure QKD, (b) MDI QKD, and (c) MUB-QCT. In general, hardware in Alice and Bob's labs comprise classical storage, a classical processing device and a device to perform quantum operations. This hardware may require some trust factor depending on their utility in the protocol. For instance, in preparation and measure type QKD protocols it is assumed that these devices work exactly according to their specifications, and are shielded, i.e., they do not leak any information from leaking out of the lab. As a result of this, it is required for Alice to know the specifications of devices in Bob's lab, in another way, the security of the protocol inherently depends on the security of these devices. However, such a condition is difficult to ensure when implementing the protocol, as many attacks have been demonstrated to be directed towards quantum devices [52–54].

In Measurement Device Independent (MDI) QKD [55, 56], any detector vulnerability is removed by making no trust assumption on the measurement devices, which is the most crucial part of the implementation and quantum transmitter and only classical processing devices are assumed to work according to their specifications. Consequently, the measurement device is located outside Alice and Bob's lab, as shown in the Figure (8). As a result, the security of the protocol does not depend on the security of measurement devices, offering an important implementation security advantage.

Device independent (DI) QKD [57, 58] is another security framework providing unparalleled security, which holds irrespective of the quality and internal working of quantum devices (transmitter and receiver). DI-QKD protocols derive their security from an important ingredient which allows a “test for quantumness” based on the violation of a Bell-inequality [59–62]. Such test for quantumness can only guarantee the security of the cryptographic protocol if it allows the violation of Bell inequality in a loophole-free way (in particular, this means that

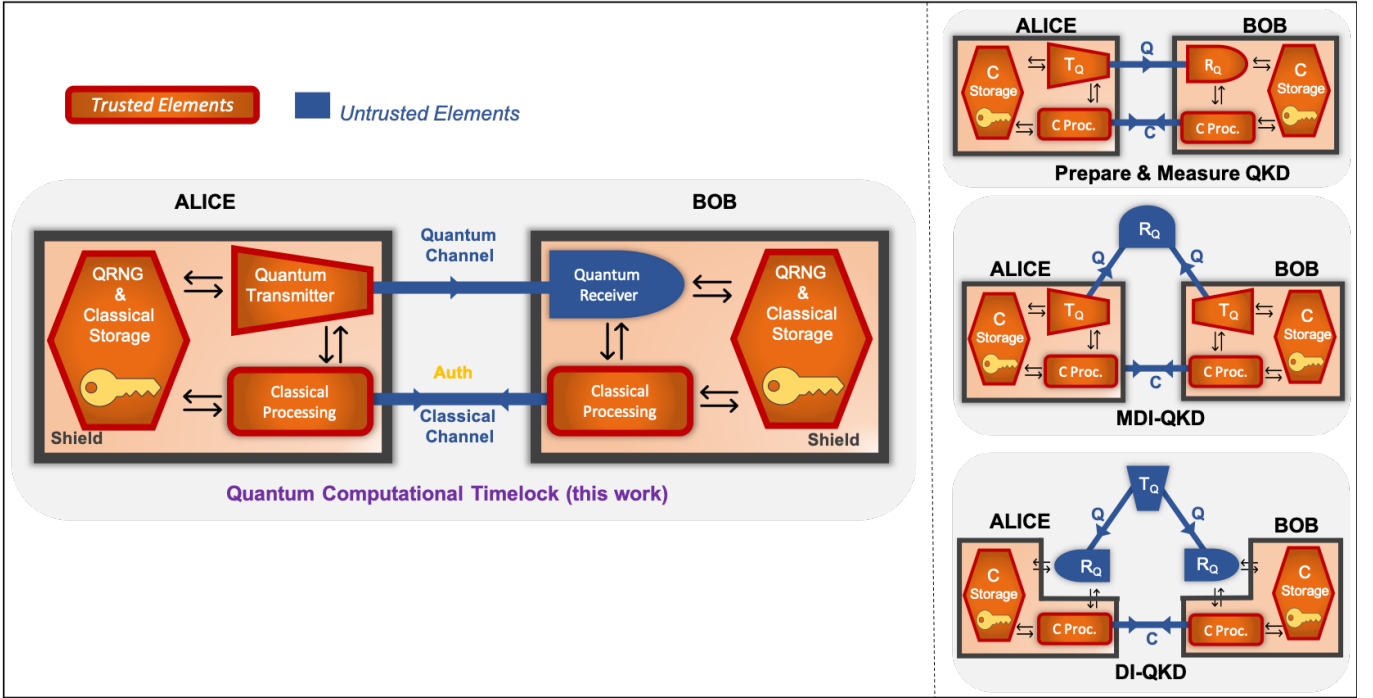

FIG. 8. Trust assumptions on the hardware, required to prove security in different key distribution protocols. Elements that are trusted to work according to their specifications are represented in orange color, while, for elements in blue color, no assumptions are made on the internal working and specifications, removing an important constraint on the security of the protocol. The black color boundary represents the shield, which ensures that these devices do not leak any information out of the lab. In the figure shorthand notations are defined as,  $T_Q$ : quantum transmitter,  $R_Q$ : quantum receiver,  $C$ : classical, and,  $Q$  quantum. The yellow color key is a short key required to generate short-term-secure encryption in QCT and also serve as an initial password to authenticate the classical channel.

the experiments should be executed without making any assumptions that could otherwise be exploited by Eve to compromise the security of a cryptographic protocol). However, DI-QKD makes some important assumptions like, there is no information leakage from trusted parties' locations and Alice and Bob have access to trusted randomness. These two assumptions are the cryptographic analogous of the locality (no-signaling) and free-will loophole respectively. If these, two assumptions can not be met (loopholes can not be closed), a secure key distribution (proper Bell violation) can not be guaranteed. This high level of security can only be established under conditions which are very difficult to achieve experimentally, as among the recent experimental demonstration [63–65], claiming loophole-free Bell inequality violation, have however only closed the door on local and non-contextual theories with fake determinism and are not completely loophole-free [66]. Moreover, it has already been shown that quantum theory, with all its seemingly nonlocal predictions, can be given a fully local-realistic interpretation [67–69]. As a result, DI-QKD although, guarantee unprecedented security, yet, it is not the panacea for secure key distribution as it is difficult to implement and still requires important trust assumptions, that may not be much easier to comply with, than the one for prepare and measure QKD.

In Quantum Computational Timelock, MUB-QCT protocol, Alice and Bob are not required to estimate the errors by monitoring their channel, to bound Eve's information on the secret key. To bound Eve's information, Alice and Bob are required to calculate only the accessible information of the Eve, which depends on the input state prepared by Alice's quantum source and does not depend on Bob's measurement device. As a result, Alice is not required to know the specifications of measurement devices on Bob's side. Thus, the security is independent of any trust assumption on the measurement device. However, this kind of security is guaranteed only if the assumptions of the QCH security model holds. We call this, MDI-type security, as the security is similar to the MDI QKD protocol provided some additional restrictions.

## VII. CONCLUSION

In this paper, we proposed a new QCH security model, using which we constructed a MUB-QCT key distribution protocol, where we encode a bit on a qudit system using a basis among the full set of MUBs. We prove the security of the protocol by estimating the upper bound on the accessible information for an adversary, which is done by



calculating the maximum success probability to guess the key bit. The main ingredient to calculate the guessing probability was to show that the best strategy for an adversary corresponds to state discrimination with post-measurement information on all incoming qubits.

We proved our main result that when Alice sends  $m$  copies of the quantum state, then for a collective and non-adaptive attack strategy, Eve's accessible information on the key bit is  $I_{acc}(X; E)_m \leq \frac{1}{\ln 2} \mathcal{O}\left(\frac{2m}{\sqrt{d}}\right)$ . Implying that  $m < \sqrt{d}$  of copies can be sent by Alice to Bob, while still bounding Eve's accessible information less than Alice Bob correlation. As a result of which, we observe a significant improvement in the key rate when we opt for high dimensional encoding as evident from Figure 6.

We also showed that the security of QCT can be guaranteed without monitoring the error rate and thus there is no need to trust the implementation of Bob's measurement apparatus. This "MDI-type" security relaxes some important engineering constraints concerning QKD. The fact that the error rate does not need to be evaluated with high precision indeed represents a significant prac-

tical advantage over QKD protocols such as decoy-state QKD, where finite-size effects can strongly affect the secure key rates attainable in practice.

Hence, our results illustrated that hybrid approaches to quantum cryptography may constitute a practical and therefore very promising route to extend the performance and functionality of quantum cryptography, and to meet the requirements associated with the deployment of large-scale quantum communication infrastructures.

## VIII. ACKNOWLEDGMENT

The authors gratefully acknowledge support by European Innovative Training Network QCALL (project 675662) funded by the Marie Skłodowska Curie Call H2020-MSCA-ITN-2015 and from the Quantum Technology Flagship project CiViQ, funded by the European Union's Horizon 2020 research and innovation programme under grant agreement No 820466.

- 
- [1] K. Paterson, F. Piper, and R. Schack, *Quantum cryptography: a practical information security perspective*, arXiv:quant-ph/0406147.
- [2] R. Alléaume, C. Branciard, J. Bouda, et al., *Using quantum key distribution for cryptographic purposes: a survey*. Theoretical Computer Science, 2014, vol. 560, p. 62-81.
- [3] D. MCGrew, *Living with postquantum cryptography*, NIST Workshop on Cybersecurity in a Post-Quantum World 2015. <http://csrc.nist.gov/groups/ST/post-quantum-2015/presentations/session4-mcgrew-david.pdf>
- [4] NCSC Whitepaper on quantum security technologies, <https://www.ncsc.gov.uk/whitepaper/quantum-security-technologies> (2020).
- [5] S. Pirandola et al., *Advances in quantum cryptography*, arXiv:1906.01645 (2019).
- [6] M. Peev et al., *The SECOQC quantum key distribution network in Vienna*, New Journal of Physics 11 (2009) 075001.
- [7] M. Sasaki, *Field test of quantum key distribution in the Tokyo QKD Network* Optics express 19.11, 10387-10409. (2011).
- [8] E. Diamanti, H. K. Lo, B. Qi and Z. Yuan, *Practical challenges in quantum key distribution*, npj Quantum Information, 2(1), 1-12, (2016).
- [9] Q. Zhang, F. Xu, Y. A. Chen, C. Z. Peng and J. W. Pan, *Large scale quantum key distribution: challenges and solutions*, Optics express, 26(18), 24260-24273. (2018).
- [10] R. Renner, *Security of Quantum Key Distribution*, PhD thesis, ETH Zurich, 2005.
- [11] V. Scarani et al., *The security of practical quantum key distribution*, Reviews of modern physics 81.3 (2009): 1301.
- [12] M. Tomamichel and A. Leverrier, *A largely self-contained and complete security proof for quantum key distribution.*, Quantum 1 (2017): 14.
- [13] M. Lucamarini et. al., *Implementation Security of Quantum Cryptography*, ETS White Paper, ISBN No. 979-10-92620-21-4, (2018).
- [14] F. Xu, X. Ma, Q. Zhang, H. K. Lo and J. W. Pan, *Secure quantum key distribution with realistic devices*, arXiv preprint arXiv:1903.09051, (2019).
- [15] V. Scarani and C. Kurtsiefer, *The black paper of quantum cryptography: real implementation*, Theoretical Computer Science 560 (2014): 27-32.
- [16] D. Unruh, *Everlasting Quantum Security*, IACR Cryptology ePrint Archive, 2012, 177. (2012).
- [17] M. Takeoka, S. Guha, and M. M. Wilde, *Fundamental rate-loss tradeoff for optical quantum key distribution*, Nat Commun 5, 5235 (2014).
- [18] S. Pirandola, R. Laurenza, C. Ottaviani, and L. Banchi. *Fundamental limits of repeaterless quantum communications*, Nat Commun 8, 15043 (2017).
- [19] D. Bernstein, *Cost-benefit analysis of quantum cryptography*, Dagstuhl Seminar 09311, 2009. <http://cr.yyp.to/talks/2009.07.28/slides.pdf>.
- [20] M. Sasaki, *Quantum networks: where should we be heading?*, Quantum Science and Technology 2.2 (2017): 020501.
- [21] D. Unruh, *Revocable quantum timed-release encryption*, (pp. 129-146), Eurocrypt 2014. Springer.
- [22] S. Wehner, C. Schaffner, and B. M. Terhal, *Cryptography from noisy storage*. Phys. Rev. Lett., 100(22), 220502.
- [23] D. Gopal, and S. Wehner, *Using postmeasurement information in state discrimination*, Phys. Rev. A 82, 022326 (2010).
- [24] Cosmo Lupo, *Quantum Data Locking for Secure Communication against an Eavesdropper with Time-Limited Storage*, Entropy, 17(5), 3194-3204 (2015).

- [25] S Guha et al., *Quantum enigma machines and the locking capacity of a  $q$  channel*, Phys. Rev. X 4 011016, (2014).
- [26] C. Lupo and S. Lloyd, *Quantum-Locked Key Distribution at Nearly the Classical Capacity Rate*, Phys. Rev. Lett. 113, 160502 (2014).
- [27] C. Lupo and S. Lloyd, *Continuous-variable quantum enigma machines for long-distance key distribution*, Phys. Rev. A 92, 062312 (2015).
- [28] Q. Zhuang, Z. Zhang, J. Dove, F. N. C. Wong, and J. H. Shapiro, *Floodlight quantum key distribution: A practical route to gigabit-per-second secret-key rates*, Phys. Rev. A 94, 012322 (2016).
- [29] Z. Zhang, Q. Zhuang, F. N. C. Wong, and J. H. Shapiro, *Floodlight quantum key distribution: Demonstrating a framework for high-rate secure communication*, Phys. Rev. A 95, 012332 (2017).
- [30] Q. Zhuang, Z. Zhang, N. Lütkenhaus, and J. H. Shapiro, *Security-proof framework for two-way Gaussian quantum-key-distribution protocols*, Phys. Rev. A 98, 032332 (2018).
- [31] S. Bandyopadhyay, P. O. Boykin, V. P. Roychowdhury, and F. Vatan. *A new proof for the existence of mutually unbiased bases*. Algorithmica, 34(4):512–528, 2002.
- [32] T. Durt, B.-G. Englert, I. Bengtsson, K. Życzkowski. *On mutually unbiased bases*, Int. J. Quantum Inf. 2010, 8, 535-640.
- [33] P. Wocjan and T. Beth. *New Construction of Mutually Unbiased Bases in Square Dimensions*, QIC, 5(2):129-158,2005.
- [34] R. Alicki and M. Fannes, *Continuity of Quantum Conditional Information*, J. Phys. A 2004, 98, L55.
- [35] A. A. Fedotov and F. Topsoe, *Refinements of Pinsker’s inequality*, IEEE Trans. Inf. Theory 2003, 49, 1491-1498.
- [36] U. Maurer, *Secret key agreement by public discussion from common information*. IEEE Transactions on Information Theory, Vol. 39, No. 3, pp. 733–742, 1993.
- [37] I. Csiszár, J. Körner, *Broadcast channels with confidential messages*. IEEE Trans. Inf. Theory 24 (1978) 339–348.
- [38] U. Maurer and S. Wolf, *Information-theoretic key agreement: from weak to strong secrecy for free*. Proceedings of EUROCRYPT 2000, Lecture Notes in Computer Science, Vol. 1807, pp. 352–368, Springer-Verlag, 2000.
- [39] U. Maurer and S. Wolf, *Unconditionally secure key agreement and the intrinsic conditional information*, IEEE Transactions on Information Theory, Vol. 45, No. 2, pp. 499–514, 1999.
- [40] R. König, R. Renner and C. Schaffner, “*The Operational Meaning of Min- and Max- Entropy*,” in IEEE Transactions on Information Theory, vol. 55, no. 9, pp. 4337-4347, Sept. 2009.
- [41] E. Barker, *Recommendation for Key Management*, Part 1: General, NIST Special Publication 800-57 Part 1, Revision 4, *NIST.SP.800 – 57pt1r4.pdf*.
- [42] J. L. Carter and M. N. Wegman, *Universal classes of hash functions*, Journal of Computer and System Sciences, Vol. 18, pp. 143–154, 1979.
- [43] C. H. Bennett, G. Brassard, C. Crépeau, and U. M. Maurer, *Generalized privacy amplification*. IEEE Transactions on Information Theory, Vol. 41, No. 6, pp. 1915–1923, 1995.
- [44] P. Skrzypczyk and D. Cavalcanti, *Loss-tolerant EPR steering for arbitrary dimensional states: joint measurability and unbounded violations under losses*, Phys. Rev. A 92, 022354 (2015).
- [45] C. Schaffner, *Cryptography in the Bounded Quantum Storage Model*, arXiv:0709.0289.
- [46] M. Tomamichel, S. Fehr, J. Kaniewski and S. Wehner, *A Monogamy of Entanglement Game With Applications to Device Independent Quantum Cryptography*, New J. Phys. 15, 103002 (2013)
- [47] V. Scarani, H. B.-Pasquinucci, N. J. Cerf, M. Dusek, N. Lutkenhaus and M. Peev, *The security of practical quantum key distribution*. Rev. Mod. Phys. 81, 1301 (2009)
- [48] A. Acin, E. Bagan, M. Baig, Ll. Masanes and R. Muñoz-Tapi, *Multiple copy 2-state discrimination with individual measurements*. Phys. Rev. A 71 032338 (2005).
- [49] J.-I. Yoshikawa, et al., Invited article: *Generation of one-million-mode continuous-variable cluster state by unlimited time-domain multiplexing*, APL Photonics 1.6 (2016): 060801.
- [50] A. Boaron, G. Boso, D. Rusca, C. Vulliez, C. Autebert, M. Caloz, M. Perrenoud, G. Gras, F. Bussières, M.-J. Li, D. Nolan, A. Martin and H. Zbinden, *Secure Quantum Key Distribution over 421 km of Optical Fiber*, Phys. Rev. Lett. 121, 190502 (2018).
- [51] L. C. Comandar et al., *Room temperature single photon detectors for high bit rate quantum key distribution*. Appl. Phys. Lett. 104, 021101 (2014).
- [52] B. Qi, C.-H. Fred Fung, H.-K. Lo, X. Ma. *Time-shift attack in practical quantum cryptosystems*, Quant. Inf. Comp. 7, pp. 73-82 (2007).
- [53] Y. Zhao, C.-H. Fred Fung, B. Qi, C. Chen, and H.-K. Lo, *Quantum hacking: Experimental demonstration of time-shift attack against practical quantum-key-distribution systems*, Phys. Rev. A 78, 042333 (2008).
- [54] Lydersen, L., Wiechers, C., Wittmann, C. et al., *Hacking commercial quantum cryptography systems by tailored bright illumination*, Nature Photon 4, 686–689 (2010).
- [55] H. K. Lo, M. Curty, and B. Qi, *Measurement Device Independent Quantum Key Distribution*, Phys. Rev. Lett. 108, 130503 (2012).
- [56] S. L. Braunstein and S. Pirandola, *Side Channel Free Quantum Key Distribution*, Phys. Rev. Lett. 108, 130502 (2012).
- [57] A. K. Ekert and R. Renner, *The ultimate physical limits of privacy*, Nature 507, 443–447 (2014).
- [58] Antonio Acín, Nicolas Brunner, Nicolas Gisin, Serge Massar, Stefano Pironio, and Valerio Scarani, *Device-Independent Security of Quantum Cryptography against Collective Attacks*, Phys. Rev. Lett. 98, 230501 (2007).
- [59] A. K. Ekert, *Quantum cryptography based on Bell’s theorem*, Phys. Rev. Lett. 67, 661 (1991).
- [60] D. Mayers and A. Yao, *Quantum cryptography with imperfect apparatus*, In Proc. 39th Annual Symposium on Foundations of Computer Science, 1998, 503–509 (IEEE, 1998).
- [61] J. Barrett, L. Hardy, and A. Kent, *No signaling and quantum key distribution*, Phys. Rev. Lett. 95, 010503 (2005).
- [62] A. Acin and L. Masanes, *Certified randomness in quantum physics*, Nature 540, 213–219 (2016).
- [63] Hensen, B. et al., *Loophole-free Bell inequality violation using electron spins separated by 1.3 kilometres*, Nature 526, 682–686 (2015).
- [64] L. K. Shalm, et al., *Strong loophole-free test of local realism*, Phys. Rev. Lett. 115, 250402 (2015).

- [65] M. Giustina et al. *Significant - loophole - free test of bell - Bell's theorem with entangled photons*, Phys. Rev. Lett. 115, 250401 (2015).
- [66] G. Brassard and P. R. Robichaud, *The equivalence of local - realistic and no-signalling theories*, arXiv:1710.01380 [quant-ph].
- [67] G. Brassard and P. R. Robichaud, *Can free will emerge from determinism in quantum theory?”, in Is Science Compatible with Free Will? Exploring Free Will and Consciousness in the Light of Quantum Physics and Neuroscience*, Springer, pp. 41–61, 2013.
- [68] G. Brassard and P. R. Robichaud, *Parallel lives: A local-realistic interpretation of 'nonlocal' boxes*, arXiv:1709.10016, 2017.
- [69] D. Deutsch and P. Hayden, *Information flow in entangled quantum systems*, Proceedings of the Royal Society of London A456(1999):1759–1774, 2000
- [70] Y. Wang, M. Um, J. Zhang, S. An, M. Lyu, J.-N. Zhang, L.-M. Duan, D. Yum and K. Kim, *Single-qubit quantum memory exceeding ten-minute coherence time*, Nature Photonics 11, 646–650 (2017).
- [71] M. Lettner, et al. *Remote Entanglement between a Single Atom and a Bose-Einstein Condensate*. Phys. Rev. Lett. 106, 210503 (2011).
- [72] B. Pingault, D. Jarasch, C. Hepp, et.al., *Coherent control of the silicon-vacancy spin in diamond*, Nat Commun 8, 15579 (2017).
- [73] E. Poem, C. Weinzetl, J. Klatzow, K. T. Kaczmarek, J. H. D. Munns, T. F. M. Champion, D. J. Saunders, J. Nunn, and I. A. Walmsley, *Broadband noise-free optical quantum memory with neutral nitrogen-vacancy centers in diamond*, Phys. Rev. B 91, 205108
- [74] D. D. Awschalom, R. Hanson, J. Wrachtrup and B. B. Zhou, *Quantum technologies with optically interfaced solid-state spins*, Nature Photon 12, 516-527 (2018).
- [75] M. H. Devoret and R. J. Schoelkopf, *Superconducting Circuits for Quantum Information: An Outlook*, Science 339, 1169 (2013).
- [76] N. Kalb, A. Reiserer, S. Ritter and G. Rempe, *Heralded Storage of a Photonic Quantum Bit in a Single Atom*, Phys. Rev. Lett. 114, 220501 (2015).
- [77] K. F. Reim, J. Nunn, V. O. Lorenz, B. J. Sussman, K. C. Lee, N. K. Langford, D. Jaksch, and I. A. Walmsley, *Towards high-speed optical quantum memories*, Nat. Photonics 4, 218–221 (2010).
- [78] K. F. Reim, P. Michelberger, K. C. Lee, J. Nunn, N. K. Langford, and I. A. Walmsley, *Single-photon-level quantum memory at room temperature*, Phys. Rev. Lett. 107, 053603 (2011).
- [79] Pierre Vernaz-Gris, Aaron D. Tranter, Jesse L. Everett, Anthony C. Leung, Karun V. Paul, Geoff T. Campbell, Ping Koy Lam, and Ben C. Buchler, *High-performance Raman memory with spatio-temporal reversal*, Optics Express Vol. 26, Issue 10, pp. 12424-12431 (2018).
- [80] P. Jobez, C. Laplane, N. Timoney, N. Gisin, A. Ferrier, P. Goldner, and M. Afzelius, *Coherent spin control at the quantum level in an ensemble-based optical memory*, Phys. Rev. Lett. 114, 230502 (2015).
- [81] A. Ortu, A. Tiranov, S. Welinski, F. Froewis, N. Gisin, A. Ferrier, P. Goldner and M. Afzelius, *Simultaneous coherence enhancement of optical and microwave transitions in solid-state electronic spins*, Nature Materials 17, 671-675 (2018).
- [82] A. Holzäpfel, J. Etesse, Krzysztof T. Kaczmarek, A. Tiranov, N. Gisin and M. Afzelius, *Optical storage on the timescale of a second in a solid-state atomic frequency comb memory using dynamical decoupling*, arXiv:1910.08009 [quant-ph]
- [83] J. L. Everett, P. Vernaz-Gris, G. T. Campbell, A. D. Tranter, K. V. Paul, A. C. Leung, P. K. Lam, and B. C. Buchler, *Time-reversed and coherently enhanced memory: A single-mode quantum atom-optic memory without a cavity*, Phys. Rev. A 98, 063846 (2018)
- [84] Y.-H. Chen, M.-J. Lee, I.-C. Wang, S. Du, Y.-F. Chen, Y.-C. Chen, and I. A. Yu, *Coherent Optical Memory with High Storage Efficiency and Large Fractional Delay*, Phys. Rev. Lett. 110, 083601 (2013).
- [85] Y.-C. Wei, Y.-F. Hsiao, and Y.-C. Chen, *Demonstration of high performance on broadband storage with Electromagnetically induced transparency based cold atom memory*, arXiv:2003.00945 [physics.atom-ph].
- [86] Y.-W. Cho, G. T. Campbell, J. L. Everett, J. Bernu, D. B. Higginbottom, M. T. Cao, J. Geng, N. P. Robins, P. K. Lam, and B. C. Buchler, *Highly efficient optical quantum memory with long coherence time in cold atoms*, Optica Vol. 3, Issue 1, pp. 100-107 (2016).
- [87] E. Bimbard, R. Boddada, N. Vitrant, A. Grankin, V. Parigi, J. Stanojevic, A. Ourjoumtsev, and P. Grangier, *Homodyne tomography of a single photon retrieved on demand from a cavity-enhanced cold atom memory*, Phys. Rev. Lett. 112, 033601 (2014).
- [88] M. A. Nielsen and I. Chuang. *Quantum Computation and Quantum Information*. Cambridge University Press, 2000.

#### Appendix A: Validity of time-limited quantum storage assumption

The practical implementation of an attack by an adversary on the time-limited quantum storage assumption will require efficient quantum storage with coherence time greater than the computational time ( $t_{coh} > t_{comp}$ ), i.e., an adversary needs to be able to store quantum information for a time greater than the time for which encryption is assumed to be secure, and retrieve it on-demand later. A natural question to be asked is how plausible it is to achieve this requirement? To provide the answer we discuss today's quantum storage capabilities, by analyzing different experimental demonstrations of state of the art quantum memories. For the comparison, we only consider those experimentally demonstrated quantum memories,

- Which have shown storage of optically interfaced quantum light
- Storing light at a single photon level (quantum regime).

Based on the approach to light-matter coupling, we categorize quantum memories into two categories. The first is a single atom-based quantum memory, where a single atom is placed in a highly reflective optical cavity. Light

Type of Quantum Memory	Approaches	Platform	Storage & retrieval Efficiency	Coherence Time
Single atom based quantum memories	Trapped ions [71]	Cold atoms	16%	139 $\mu$ s
	Nuclear spin	SiV centre [73]	NA	115ns
	Nuclear spin	NV centre ( <i>proposed</i> ) [72]	25%	40ns
	Cavity QED [76]	Cold atoms	39%	3 $\mu$ s
Ensemble based quantum memories	AFC [82]	Solid state	0.5%	0.53s
	EIT [84]	Cold gas	56%	54 $\mu$ s
	Raman scheme [79]	Cold atoms	65%	60 $\mu$ s
	Cavity [83]	Cavity	72%	110 $\mu$ s
	DLCZ [87]	Cold gas	82%	0.9 $\mu$ s
	GEM [86]	Cold gas	87%	1ms

TABLE II. Quantum storage time of different state of the art quantum memory systems. For the comparison, we considered experimentally demonstrated quantum memories which have shown storage of optically encoded quantum light, and are at single-photon level.

shining into the cavity repeatedly reflects from its mirrors which can dramatically increase the absorption of an incoming photon. Another approach is ensemble-based quantum memories or collective coupling. An ensemble of atoms is prepared in the ground state which is in a large superposition. The incoming photon is absorbed by the ensemble such that the state of the photon is delocalized over all the atoms in the ensemble. The collective state is then efficiently converted back into a single photon with a well-defined direction. We also report the storage and retrieval efficiency of these memories.

### 1. Single atom-based quantum memories:

Memories such as *trapped ions*: have been shown to exhibit long coherence times on the order of 10 min [70] though, not optically interfaced. Nevertheless, these memories can be optically interfaced by tuning the optical resonator's frequency near an atomic transition to create a dipole coupling between the atoms and the cavity field. For storage of photonic qubit in a single atom, the overall storage and retrieval efficiency of 16% for coherence time of 139 $\mu$ s was recorded [71].

Quantum memory based on solid-state nuclear spin systems, such as *Silicon-vacancy centres* (SiVC) in diamonds have shown a coherence time of 115ns [72]. For

*Nitrogen-vacancy centers* (NVC) in diamonds an experiment was proposed [73], which offers to achieve a coherence time of 40ns with an overall efficiency of 25%. A detailed review of optically interfaced solid-state quantum memories can be found here, [74].

*Superconducting circuit QED* are hybrid systems that have shown to exhibit a coherence time up to 100s [75]. However, since microwave photons are not well suited for long-distance communication, an optical-to-microwave interface is needed which introduces noise due to optical interactions. Heralded transfer of a polarization qubit from a photon onto a single atom with 39% efficiency and storage time of 3 $\mu$ s was realized [76].

### 2. Ensemble-based quantum memories:

These memories have preferential importance due to their strong light-matter coupling and high bandwidths. The collective state in an ensemble of atoms is more robust to environmental dephasing. A large ensemble facilitates storing multiple photons in a single memory. A list of techniques has been deployed to develop such quantum memories.

Warm vapor *Raman memory schemes* have been used to efficiently store GHz-bandwidth photons for up to nanoseconds with an efficiency of 30% [77, 78] and with

cold atoms, the efficiency is of 65% with coherence time  $60 \mu\text{s}$  [79]. Electromagnetically Induced Transparency (EIT) is an optical phenomenon in atoms that uses quantum interference to induce transparency into an otherwise resonant and opaque medium. For quantum memory application using EIT, the coherence time was recorded up to  $54 \mu\text{s}$  with an efficiency of 56% [84]. Both EIT and Raman memory schemes are optically controlled quantum memories, where a strong optical pulse is used to induce the absorption of photons into the storage medium. The main challenge of optically controlled quantum memories is the noise, in particular, as the single-photon level signal is emitted with a strong control beam, due to which the residual control beam becomes a serious source of noise in the single-photon signal band.

Another important scheme of quantum memory is called engineered absorption, which is based on the photon echo effect. There are two important approaches in this scheme: Controlled Reversible Inhomogeneous Broadening (CRIB) (*Gradient Echo Memories* GEM) and *Atomic Frequency Combs* (AFC). Memories designed using the GEM method have shown very high efficiency up to 90% with coherence time-limited to  $100 \mu\text{s}$ . Laser-cold atoms used for GEM have produced an efficiency of 87% with a coherence time of  $0.6 \text{ ms}$  [86]. Solid-state AFC has shown lifetime storage up to few hundreds of ms, however, the efficiency is very low [80–82].

An *optical cavity* is an effective method to enhance atom-light coupling strength. The cavity retains the photon and releases it when needed. The main advantages of a cavity-based quantum memory are its simple and inexpensive configuration and the very broad working wavelength range. However, due to the loss of the cavity, it cannot provide a long storage time. It has shown the efficiency of 72% with the coherence time of  $110 \mu\text{s}$  [83].

**Analysis:** Our review indicates that among the recent experimental demonstrations of quantum memories the coherence time is limited to the few seconds. A comparison of efficiency and coherence time of different quantum memory systems is shown in Table [II]. Figure (3) illustrates the analysis of the validity QCH security model. On the timeframe, the red shaded area on the left represents the state of art quantum memories which can attack the QCH security model and have coherence time of order as a second i.e.,  $\mathcal{O}(1)\text{s}$ . The red shaded area on the right represents the time-limit for which AES-256 encryption is assumed to be secure i.e.,  $10^9\text{s}$  [41]. The green shaded region in the center represents the high assurance region for the validity of the QCH security model. Thus, assuming for example  $t_{comp} = 10^5 \text{ s} \sim 1 \text{ day}$  leaves a reasonable security margin, with respect to the state of art in quantum storage capabilities.

### Appendix B: Proof of Proposition 1

We consider the case where the noise is Markovian in nature, that is, the family  $\{\mathcal{N}_t\}_{t>0}$  is a continuous one-

parameter semi-group

$$\mathcal{N}_0 = \mathbb{I} \quad \text{and} \quad \mathcal{N}_{t_1+t_2} = \mathcal{N}_{t_1} \circ \mathcal{N}_{t_2}. \quad (\text{B1})$$

Thus for Markovian evolution of state i.e.,  $\rho \rightarrow \mathcal{N}_{t_1}(\rho) \rightarrow \mathcal{N}_{t_1+t_2}(\rho)$  we have following data processing inequality [88],

$$H(X|\rho) \leq H(X|\mathcal{N}_{t_1}(\rho)) \leq H(X|\mathcal{N}_{t_1+t_2}(\rho)) \quad (\text{B2})$$

The entropy associated with the strategy S1 and strategy S2 are

$$H_{S1} = H(X|\rho_{x^n\theta^n}) \quad (\text{B3})$$

$$H_{S2} = H(X|\mathcal{N}_{t_{comp}}(\rho_{x^{n-l}\theta^{n-l}})) + H(X|\rho_{x^l\theta^l}) \quad (\text{B4})$$

Now since  $t_{coh} < t_{comp}$  then following the data processing inequalities from Equation (B2), we have

$$H(X|\mathcal{N}_{t_{coh}}(\rho_{x^{n-l}\theta^{n-l}})) \leq H(X|\mathcal{N}_{t_{comp}}(\rho_{x^{n-l}\theta^{n-l}})) \quad (\text{B5})$$

Which implies

$$H_{S2} \geq H(X|\mathcal{N}_{t_{coh}}(\rho_{x^{n-l}\theta^{n-l}})) + H(X|\rho_{x^l\theta^l}) \quad (\text{B6})$$

Given the fact that the quantum state at the end of  $t_{coh}$  is  $\epsilon$  close to the identity  $\mathbb{I}$ , we have

$$H(X|\mathcal{N}_{t_{coh}}(\rho_{x^{n-l}\theta^{n-l}})) \geq H(X|\rho_{x^{n-l}\theta^{n-l}}) \quad (\text{B7})$$

Which implies,

$$\begin{aligned} H_{S2} &\geq H(X|\rho_{x^{n-l}\theta^{n-l}}) + H(X|\rho_{x^l\theta^l}) \\ H_{S2} &\geq H(X|\rho_{x^n\theta^n}) \\ H_{S2} &\geq H_{S1} \end{aligned} \quad (\text{B8})$$

Finally, this proves

$$P_{guess}(S1) > P_{guess}(S2). \quad (\text{B9})$$

### Appendix C: Calculation for secret key rate

Consider a lossy channel, with  $T$  the transmittance of the channel, defined as  $T = 10^{-\alpha L/10}$ ,  $\alpha = 0.2 \text{ dB/km}$ . Let there be  $n$  detectors, with  $\eta$  be the detector efficiency,  $V$  be the visibility of the detection and  $p_{dark}$  the dark-count probability per detector then,

1. When sending  $m$ -copies, the probability that at least one copy reaches one of the detector is  $(1 - (1-T)^m)$  and the probability that no signal reaches the detector is  $(1-T)^m$ .
2. The probability that there is click due to signal in a detector is

$$\begin{aligned} P1 &= P[\text{click due to signal}] \\ &= \left( \sum_{i=1}^m C_i^m (T\eta)^i (1-T\eta)^{m-i} \right). \end{aligned} \quad (\text{C1})$$

The probability that the signal is detected correctly in a good detector is

$$P2 = P[\text{click due to signal in a good detector}] \\ = \left( \sum_{i=1}^m C_i^m (T\eta)^i (1 - T\eta)^{m-i} \cdot V^i \right). \quad (\text{C2})$$

Similarly, the probability that the signal is detected correctly in the bad detectors

$$P3 = P[\text{click due to signal in bad detectors}] \\ = \left( \sum_{i=1}^m C_i^m (T\eta)^i (1 - T\eta)^{m-i} \cdot (1 - V)^i \right) \quad (\text{C3})$$

3. If there are  $n$  detectors the probability of click in  $k \leq n$  detectors due to dark counts is

$$P4 = P[\text{click in } k \text{ detectors due to dark count}] \\ = C_k^n (p_{dark})^k (1 - p_{dark})^{n-k} \quad (\text{C4})$$

Which for  $k = 1$  is  $np_{dark}(1 - p_{dark})^{n-1} \approx np_{dark}$  for  $p_{dark} \ll 1$ , and the probability that there is no click due to dark count is,  $(1 - p_{dark})^n$ . Thus, the probability that there is click in a good detector

due to dark counts is

$$P5 = P[\text{click in good detector due to dark count}] \\ = np_{dark} \frac{1}{n} = p_{dark}. \quad (\text{C5})$$

Similarly, the probability that there is click in the bad detectors due to dark counts is

$$P6 = P[\text{click in bad detector due to dark count}] \\ = np_{dark} \frac{n-1}{n} = (n-1)p_{dark}. \quad (\text{C6})$$

4. Probability that there is a click in the detector is  $P[\text{click due to signal}] \times P[\text{click in a detector due to dark count}]$

$$P[\text{click}] = \left( \sum_{i=1}^m C_i^m (T\eta)^i (1 - T\eta)^{m-i} \right) \times np_{dark} \quad (\text{C7})$$

Let  $P_{right}$  is the probability that there is a click in a detector and is correctly detected, while,  $P_{wrong}$  the probability that there is a click in a detector and an error in detection. Then, the probability  $P_{right}$  is then the sum of three different events

$$P_{right} = P[\text{click due to signal in good detector and no click due to dark counts}] \\ + P[\text{no click due to signal and there is click due to dark count in a good detector}] \\ + P[\text{click due to signal in good detector and click due to dark count in a good detector}] \\ = \left( \sum_{i=1}^m C_i^m (T\eta)^i (1 - T\eta)^{m-i} \cdot V^i \right) (1 - p_{dark})^n + (1 - T\eta)^m p_{dark} \\ + \left( \sum_{i=1}^m C_i^m (T\eta)^i (1 - T\eta)^{m-i} \cdot V^i \right) p_{dark} \quad (\text{C8})$$

Similarly, the probability  $p_{wrong}$  is the sum of three different events

$$P_{wrong} = P[\text{click due to signal in bad detector and no click due to dark counts}] \\ + P[\text{no click due to signal and there is click due to dark count in bad detectors}] \\ + P[\text{click due to signal in bad detector and click due to dark count in bad detectors}] \\ = \left( \sum_{i=1}^m C_i^m (T\eta)^i (1 - T\eta)^{m-i} \cdot (1 - V)^i \right) (1 - p_{dark})^n + (1 - T\eta)^m (n-1) p_{dark} \\ + \left( \sum_{i=1}^m C_i^m (T\eta)^i (1 - T\eta)^{m-i} \cdot (1 - V)^i \right) (n-1) p_{dark} \quad (\text{C9})$$

Let,  $p_c$  be the probability that there is a correct detection given that there is a click in detector, and let,  $p_e$  be the probability that there is a wrong detection given that

there is a click in detector, then

$$p_c = \frac{P_{right}}{P[\text{click}]} \quad (\text{C10})$$

$$p_e = \frac{P_{wrong}}{P[\text{click}]} \quad (\text{C11})$$



Assuming that the error in detection is uniformly distributed over  $n - 1$  detectors then,

$$H(X|Y) = -p_c \log p_c - p_e \log \frac{p_e}{n-1}. \quad (\text{C12})$$

Hence, for a lossy channel, the key rate is then

$$\begin{aligned} K &\geq (1 - (1 - T)^m) H_{\min}(X|Z) - H(X|Y) \\ &\geq (1 - (1 - T)^m) (-\log(P_{\text{guess}}(m))) \\ &\quad + p_c \log p_c + p_e \log \frac{p_e}{n-1} \end{aligned} \quad (\text{C13})$$

#### Appendix D: Bounding the norm of sum of $l$ rank-1 projector

Following inequality holds for the sum of  $l$  rank-1 projectors acting on an arbitrary finite dimensional Hilbert space  $\mathbb{C}^d$

$$\begin{aligned} \|O_1 + \dots + O_l\| &\leq 1 + (l - 1) \cos \phi \\ \cos \phi &= \max_{i,j>1} \|O_i O_j\| \end{aligned} \quad (\text{D1})$$

**Proof:** Let us introduce an auxiliary Hilbert space  $\mathbb{C}^l$ , and define a standard basis  $|i\rangle, i = 1, \dots, l$ , for this space. Consider then an operator  $Q$  acting on  $\mathbb{C}^l \otimes \mathbb{C}^d$

$$Q = \sum_i |1\rangle\langle i| \otimes O_i \quad (\text{D2})$$

which is a block matrix with the first blockrow containing the projectors  $O_i$ . Using the fact that  $\|Q^\dagger Q\| = \|QQ^\dagger\|$ , we have

$$\begin{aligned} QQ^\dagger &= |1\rangle\langle 1| \otimes \sum_i O_i, \\ Q^\dagger Q &= \sum_{ij} |i\rangle\langle j| \otimes O_i O_j \end{aligned} \quad (\text{D3})$$

Clearly  $\|QQ^\dagger\| = \|O_1 + \dots + O_l\|$ , therefore, it is now the task to bound  $\|Q^\dagger Q\|$ . We can write

$$Q^\dagger Q = \sum_i |i\rangle\langle i| \otimes O_i + \sum_{j=1}^{l-1} \sum_i |i\rangle\langle i \oplus j| \otimes O_i O_{i \oplus j} \quad (\text{D4})$$

where  $\oplus$  denotes addition modulo  $l$ . This decomposition amounts to writing  $Q^\dagger Q$  as a block diagonal matrix plus a sum of  $l - 1$  matrices, each with a block structure and containing only displaced diagonals (i.e. have the structure of a block permutation matrix).

The first term of the right hand side of the above equation has operator norm

$$\left\| \sum_i |i\rangle\langle i| \otimes O_i \right\| = \max_i \|O_i\| = 1 \quad (\text{D5})$$

since the operator norm of a block diagonal operator is the maximal operator norm of any block, which in our

case is unity. For each of the remaining terms we can use the fact that the operator norm, being equal to the largest singular value, is invariant under the transformation  $Q \rightarrow UQV$  where  $U$  and  $V$  are unitary operators. Choosing  $U = \mathbb{1} \otimes \mathbb{1}$  and  $V_j = \sum_i |i \oplus j\rangle \otimes \mathbb{1}$ , we see that

$$U \sum_i |i \oplus j\rangle \otimes O_i O_{i \oplus j} V_j = \sum_i |i\rangle\langle i| \otimes O_i O_{i \oplus j} \quad (\text{D6})$$

and thus

$$\left\| \sum_i |i\rangle\langle i \oplus j| \otimes O_i O_{i \oplus j} \right\| = \max_i \|O_i O_{i \oplus j}\| \quad (\text{D7})$$

again due to the block structure of the transformed matrix. Since  $\max_i \|O_i O_{i \oplus j}\| \leq \max_{i,j>1} \|O_i O_{i \oplus j}\| = \cos \phi$ , we can place the same bound  $\cos \phi$  on each of the  $l - 1$  terms. Finally by using repeatedly the triangle inequality we obtain

$$\|O_1 + \dots + O_l\| \leq 1 + (l - 1) \cos \phi, \quad (\text{D8})$$