Residual Shuffle-Exchange Networks for Fast Processing of Long Sequences

Andis Draguns¹ Emīls Ozoliņš¹ Agris Šostaks¹ Matīss Apinis¹ Kārlis Freivalds¹

Abstract

Attention is a commonly used mechanism in sequence processing, but it is of $O(n^2)$ complexity which prevents its application to long sequences. The recently introduced neural Shuffle-Exchange network offers a computation-efficient alternative, enabling the modelling of long-range dependencies in $O(n \log n)$ time. The model, however, is quite complex, involving a sophisticated gating mechanism derived from the Gated Recurrent Unit. In this paper, we present a simple and lightweight variant of the Shuffle-Exchange network, which is based on a residual network employing GELU and Layer Normalization. The proposed architecture not only scales to longer sequences but also converges faster and provides better accuracy. It surpasses Shuffle-Exchange network on the LAMBADA language modelling task and achieves state-of-the-art performance on the MusicNet dataset for music transcription while using significantly fewer parameters. We show how to combine Shuffle-Exchange network with convolutional layers establishing it as a useful building block in long sequence processing applications.

1. Introduction

More and more applications of sequence processing performed by neural networks require dealing with long inputs. A key requirement is to allow modelling of dependencies between distant parts of the sequences. Such long-range dependencies occur in natural language when the meaning of some word depends on other words in the same or previous sentence. There are important cases, e.g., to resolve coreferences, when such distant information may not be disregarded.

¹Institute of Mathematics and Computer Science University of Latvia. Correspondence to: Kārlis Freivalds <Karlis.Freivalds@lumii.lv>.

In music, dependencies occur on several scales. At the finest scale samples of the waveform correlate to form note pitches, at medium scale neighbouring notes relate to each other by forming melodies and chord progressions, at coarse scale common melodies reappear throughout the entire piece creating a coherent musical form (Thickstun et al., 2016; Huang et al., 2019). Dealing with such dependencies require processing very long sequences (several pages of text or the entire musical composition) in a manner that aggregates information from their distant parts. Especially challenging are approaches that work directly on the raw waveform.

The ability to combine distant information is even more important for algorithmic tasks where each output symbol typically depends on every input symbol. The goal of algorithm synthesis is to derive an algorithm from input-output examples which are often given as sequences. Algorithmic tasks are especially challenging due to the need for processing sequences of unlimited length. Also, generalization plays an important role since training is often performed on short sequences but testing on long ones.

The commonly used (for example in Transformers) attention mechanism is of quadratic complexity depending on the sequence length, therefore, is not an attractive choice for long sequences. Recently (Freivalds et al., 2019) introduced neural Shuffle-Exchange networks that allow modelling of long-range dependencies in sequences in $O(n \log n)$ time. The idea is very promising and offers a computation-efficient alternative to the attention mechanism.

In this paper, we present a much simpler, faster and lightweight version of the Shuffle-Exchange network which is based on the residual network idea employing Gaussian Error Linear Units (Hendrycks and Gimpel, 2016) and Layer Normalization (Ba et al., 2016) instead of gates.

We empirically validate our improved model on algorithmic tasks, LAMBADA question answering and multi-instrument musical note recognition (MusicNet dataset). It surpasses the original Shuffle-Exchange network by 2.1% on the LAMBADA language modelling task and achieves state-of-the-art 78.02 % average precision score on MusicNet, which is by 3.8% better than the previous best result.

We introduce a modification where we prepend the Resid-

ual Shuffle-Exchange network with strided convolutions to increases the speed and applicability to long sequences even more. This enables processing a sequence of length 2M symbols in only 3.97 seconds.

2. Related Work

Recurrent networks, in particular, LSTM (Hochreiter and Schmidhuber, 1997) and GRU (Cho et al., 2014) are important tools for sequence processing. They can efficiently process sequences of any length and have the ability to remember arbitrary long dependencies. Although successful at natural language processing, they process symbols one by one and have limited state memory, hence can remember only a limited number of such dependencies.

Another option is using convolutional architectures (Gehring et al., 2017). But convolutions are inherently local – the value of a particular neuron depends on a small neighbourhood of the previous layer. To bring in more distant relationships, it is common to augment the network with the attention mechanism. The attention mechanism has become a standard choice in numerous neural models, including Transformer (Vaswani et al., 2017) and BERT (Devlin et al., 2018) which achieve state-of-the-art accuracy in NLP and related tasks. But the complexity of the attention mechanism is quadratic depending on the input length and does not scale to long sequences.

An obvious way to overcome the complexity of attention is cutting the sequence into short segments and using attention only within the segment boundaries (Al-Rfou et al., 2018). To, at least partially, recover the lost information, recurrent connections can be added between the segments (Dai et al., 2019). Sparse transformers (Child et al., 2019) reduce the complexity of attention to $O(n\sqrt{n})$ by attending only to a small predetermined subset of locations. Star-Transformer (Guo et al., 2019) sparsifies attention even more by pushing all the long-range dependency information through one central node and reaches linear time performance. (Clark and Gardner, 2017) enable document level question answering by preselecting the paragraph most likely to contain the answer. Reformer (Kitaev et al., 2020) uses locality-sensitive hashing to approximate attention in time $O(n \log n)$.

A different way to capture long-range structure is to increase the receptive field of convolution by using dilated (atrous) convolution, where the convolution mask is spread out at regular spatial intervals. Dilated architectures have achieved great success in image segmentation (Yu and Koltun, 2015) and audio generation (van den Oord et al., 2016).

An important use of sequence processing models is in learning algorithmic tasks (see (Kant, 2018) for a good overview) where the way how to access memory is crucial. Attention mechanism to access memory is used in Pointer Networks

(Vinyals et al., 2015). Specialized memory modules, which are controlled by a mechanism similar to attention, are used by Neural Turing Machine (Graves et al., 2014) and Differentiable Neural Computer (Graves et al., 2016). Neural GPU (Kaiser and Sutskever, 2015) utilizes active memory (Kaiser and Bengio, 2016) where computation is coupled with memory access. This architecture can learn fairly complicated algorithms such as long number addition and multiplication. But the computation and memory coupling introduce a limitation: for the information to travel from one end of the sequence to the other, $o(n)$ layers are required which result in $\Omega(n^2)$ total complexity. The flow of information is facilitated by introducing diagonal gates in (Freivalds and Liepins, 2018) that improves training and generalization, but does not address the performance problem caused by many layers.

For music transcription tasks convolutional architectures are common, see (Benetos et al., 2019) for a good overview. In the article introducing the MusicNet dataset (Thickstun et al., 2016) convolutional network performed the best. A notable performance on MusicNet is achieved by a convolutional network based on complex numbers (Trabelsi et al., 2018). Recently, a state-of-the-art performance was achieved by the Transformer network employing the Fourier transform of the waveform in the complex domain (Yang et al., 2019).

3. Neural Shuffle-Exchange Networks

Neural Shuffle-Exchange networks (Freivalds et al., 2019) has been recently proposed as an efficient alternative to the attention mechanism that allows modelling of long-range dependencies in sequences in $O(n \log n)$ time. Neural Shuffle-Exchange network is the neural adaption of the Shuffle-Exchange and Beneš networks which are well-known from packet routing tasks in computer networks. The Shuffle-Exchange network has a regular layered structure and consists of repeated applications of two stages – shuffle and exchange. Fig. 1 shows a Shuffle-Exchange network for

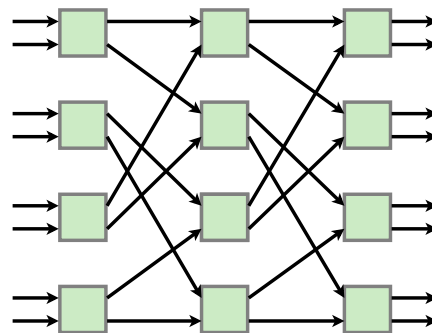

Figure 1. Shuffle-Exchange network.

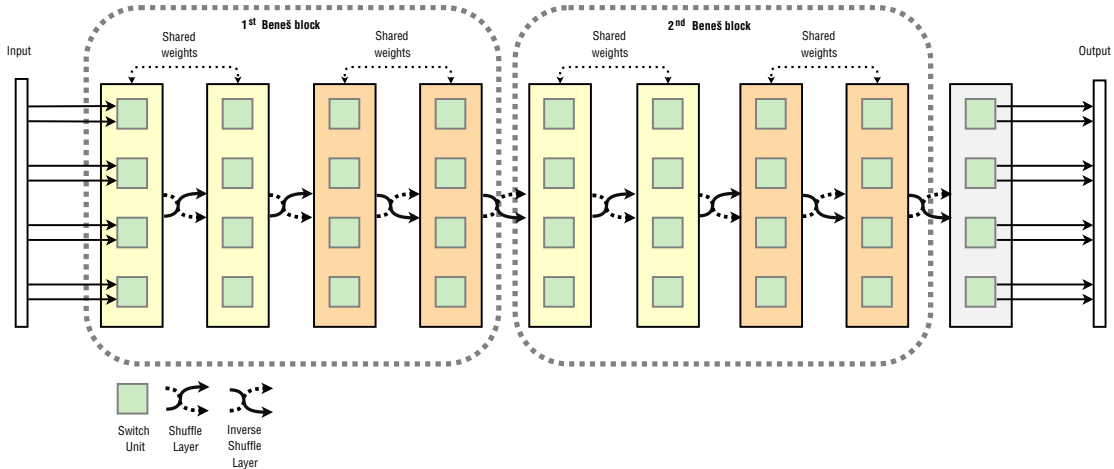

Figure 2. Residual Shuffle-Exchange network with 2 Beneš blocks and 8 inputs.

routing 8 messages from the left side to the right. First comes the exchange stage where elements are divided into adjacent pairs, and each pair is passed through a switch. The switch contains logic to select which input is routed to which output. The shuffle stage follows (depicted as arrows in the figures), where messages are permuted according to the perfect-shuffle permutation. The perfect-shuffle is a method to shuffle a deck of cards by splitting the deck into two halves and then interleaving the halves. In this permutation, the destination address is a cyclic bit shift (left or right) of the source address. The network for routing 2^k messages contains k exchange stages and $k - 1$ shuffle stages. It is proven that switches can always be programmed in a way to connect any source to any destination through the network) (Dally and Towles, 2004). But the throughput of the Shuffle-Exchange network is limited – it may not be possible to route several messages simultaneously. A better design for multiple message routing is the Beneš network.

The Beneš network is formed by connecting a Shuffle-Exchange network with its mirror copy. The mirror copy is obtained by reversing the direction of bit shift in the destination address calculation. Such a network is able to route 2^k messages to any input-to-output permutation. To do that $2k - 1$ exchange stages and $2k - 2$ shuffle stages are needed (Dally and Towles, 2004).

The neural Shuffle-Exchange network adapts the structure of Beneš network and places a learnable 2-to-2 function in each switch. The original Switch Unit of (Freivalds et al., 2019) is based on the GRU, but in this work, we give a better implementation based on a residual network.

4. The Model

We propose the Residual Shuffle-Exchange network – a simpler and faster replacement for the neural Shuffle-Exchange network. Residual Shuffle-Exchange network consists of alternating Switch Layers and Shuffle Layers and uses the same architecture and weight sharing as the neural Shuffle-Exchange network¹, for an example see Fig. 2 depicting a Residual Shuffle-Exchange network with 2 Beneš blocks for input sequence of length 8.

We replace the Switch Unit with Residual Switch Unit (RSU) employing GELU and Layer Normalization. Our network has an input of 2^k cells where each cell is a vector of size m .

In the Switch Layer, we apply RSU to adjacent non-overlapping pairs of input cells. RSU has two inputs $[i_1, i_2]$ and two $[o_1, o_2]$ outputs.

Creating the pairs technically is implemented as reshaping the sequence i into a twice shorter sequence where each new cell concatenates two adjacent cells $[i_1, i_2]$ along the feature dimension. RSU consists of two linear transformations on the feature dimension. The first linear transformation is followed by Layer Normalization (LayerNorm) without output bias and gain (Xu et al., 2019) and then by Gaussian Error Linear Unit (GELU) (Hendrycks and Gimpel, 2016). By default, we use 2x larger middle layer size than the input of the first layer, this is a good compromise of speed and accuracy (see Section 5.4). A second linear transformation is applied after GELU. The RSU is defined as follows:

¹We do not use skip connections between Beneš blocks as in the original model as they do not help our improved model.

$$\begin{aligned}
i &= [i_1, i_2] \\
g &= \text{GELU}(\text{LayerNorm}(Zi)) \\
c &= Wg + B \\
[o_1, o_2] &= \sigma(S) \odot i + h \odot c
\end{aligned}$$

In the above equations, Z , W are weight matrices of size $2m \times 4m$ and $4m \times 2m$, respectively, S is vector of size $2m$ and B is a bias vector – all of those are learnable parameters; h is scalar value, \odot denotes element-wise vector multiplication and σ is the sigmoid function.

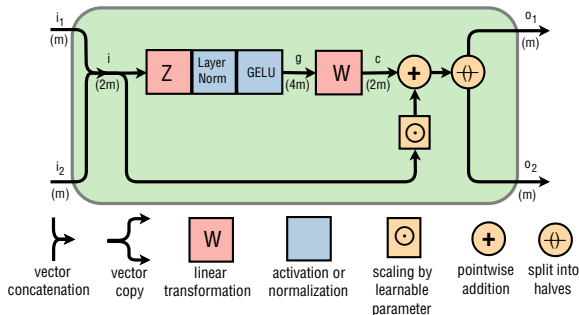

Figure 3. Residual Switch Unit. It has two inputs and two outputs. The number of feature maps is given in parenthesis.

The output of RSU is connected with its input through a residual connection. This connection is scaled by a learnable parameter S , which is restricted to the range $[0,1]$ by the sigmoid function. Additionally, we scale the new value c coming out of the last linear transformation by a constant h . We initialize S and h such that the signal travelling through the network keeps its expected amplitude at 0.25 under the assumption of the normal distribution (which is observed in practice). To have that, we initialize S as $\sigma^{-1}(r)$ and h as $\sqrt{1 - r^2} * 0.25$ where r is an experimentally chosen constant close to 1. We use $r = 0.9$, which works well. The signal amplitude after LayerNorm is 1, the weight matrix W is initialized to keep this amplitude. If the amplitude of the input is 0.25, then the expected amplitude at the output is also 0.25, which is a good range for the softmax loss. During training, the network is free to adjust these amplitudes, but this initialization provides stable convergence even for deep networks.

4.1. Prepending convolutions

There are tasks, e.g. the MusicNet task, where there is a large mismatch of information content between input and Residual Shuffle-Exchange network – each input unit contains one sample, but Residual Shuffle-Exchange network requires a large number of feature maps to work well. Encoding just one number into many feature maps is wasteful. For such tasks, we prepend the Residual Shuffle-Exchange

network with several strided convolutions to increase the number of feature maps and reduce the sequence length. We use convolutions with stride 2 and apply LayerNorm and GELU after each convolution like in the RSU. Before the result is passed to the Residual Shuffle-Exchange network, a linear transformation is applied. The structure of the network with two prepended convolutional layers for processing inputs of length 4096 is depicted in Fig. 4.

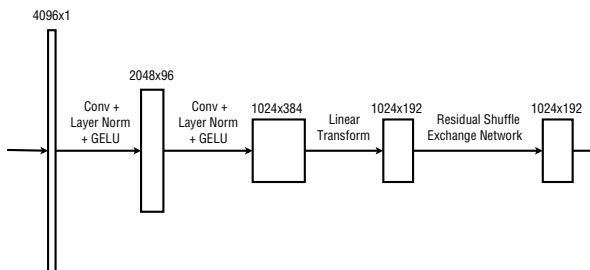

Figure 4. The architecture with two prepended convolutions employed for the MusicNet task.

Prepending convolutions shortens the input to the RSE network and speeds up processing. The obtained accuracy for the MusicNet is roughly the same, see analysis below. Note that this approach leads to a shorter output than the input. It may be necessary to append transposed convolution layers at the end of the network to upsample the signal back to its original length. For the MusicNet task, upsampling is not necessary since we utilize only a few elements of the output sequence.

5. Evaluation

We have implemented the proposed architecture in TensorFlow. The code is available at <https://github.com/LUMI-I-Syslab/RSE>. All models are trained on a single Nvidia RTX 2080 Ti (11GB) GPU with RAdam optimizer (Liu et al., 2019)

5.1. Algorithmic tasks

Let us evaluate how well the Residual Shuffle-Exchange (RSE) network performs on algorithmic tasks in comparison with the neural Shuffle-Exchange (SE) (Freivalds et al., 2019). The goal is to infer $O(n \log n)$ time algorithms purely from input-output examples. Algorithmic tasks are good benchmarks to evaluate the model’s ability to develop a rich set of long-term dependencies.

We consider long binary addition, long binary multiplication and sorting, which are common benchmark tasks in several papers including (Freivalds et al., 2019; Kalchbrenner et al., 2015; Zaremba and Sutskever, 2015; Zaremba et al., 2016;

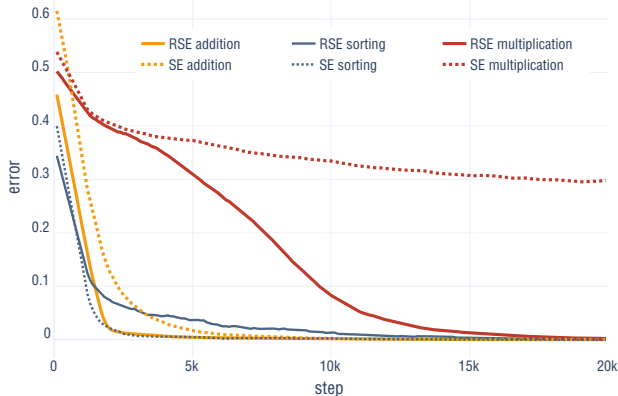

Figure 5. Comparison of Residual Shuffle-Exchange (RSE) and Shuffle-Exchange (SE) networks on algorithmic tasks length 64.

Joulin and Mikolov, 2015; Grefenstette et al., 2015; Kaiser and Sutskever, 2015; Freivalds and Liepins, 2018; Dehghani et al., 2018).

The model for evaluation consists of an embedding layer where each symbol of the input is mapped to a vector of length m , one or two Beneš blocks and the output layer which performs a linear transformation to the required number of classes with a softmax cross-entropy loss for each symbol independently. We use an RSE model having one Beneš block for addition and sorting tasks, two blocks for the multiplication task and $m = 192$ feature maps.

We use dataset generators and curriculum learning from (Freivalds et al., 2019). For training, we instantiate several models for sequence lengths (powers of 2) from 8 to 64 sharing the same weights and train each example on the smallest instance it fits. We pad the sequence up to the required length with zeroes. Figure 5 shows the testing accuracy on sequences of length 64 vs training step. We can see that on multiplication task the proposed model trains much faster than SE, reaching near-zero error in about 20K steps vs 200K steps for the SE. For addition and sorting tasks, both models perform similarly.

Next, let us compare the generalization performance of both models, see Fig. 6. We train both models on length up to 64 and evaluate on length up to 4K. On addition and sorting tasks, the proposed RSE model generalizes very well to length 256 but loses slightly to SE on longer sequences. For the multiplication task RSE model generalizes reasonably well to twice as long sequences but not more, where the old model does not generalize even this much.

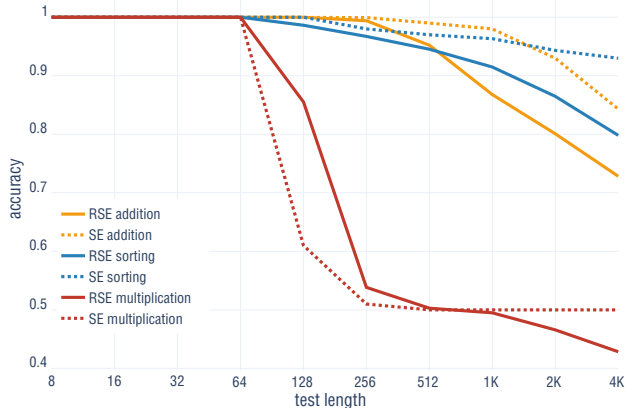

Figure 6. Comparison of Residual Shuffle-Exchange (RSE) and Shuffle-Exchange (SE) generalization to longer sequences.

5.2. LAMBADA question answering

The goal of the LAMBADA task is to predict a given target word from its broad context (on average, 4.6 sentences collected from novels). The sentences in the LAMBADA dataset (Paperno et al., 2016) are specially selected such that giving the right answer requires examining the whole passage. In 81% cases of the test set the target word can be found in the text, and we follow a common strategy (Chu et al., 2017; Dehghani et al., 2018) to choose the target word as one from the text. The answer will be wrong in the remaining cases, so the achieved accuracy will not exceed 81%.

We instantiate the model for input length 256 (all test and train examples fit in this length) and pad the input sequence to that length by placing the sequence at a random position and adding zeros on both ends. Randomized padding improves test accuracy. We use a pretrained fastText 1M English word embedding (Mikolov et al., 2018) for the input words. The embedding layer is followed by 2 Beneš blocks with 384 feature maps. To perform the answer selection as a word from the text, each symbol of the output is linearly mapped to a single scalar and we use softmax loss over the obtained sequence to select the position of the answer word.

In Table 1, we give our results in the context of previous works. The Residual Shuffle-Exchange network scores better than the Shuffle-Exchange network by 2.1% while using 3x less learnable parameters. Current state-of-the-art model GPT-2 (Radford et al., 2019) surpass our model by 8.9% while using 140 times more learnable parameters and pre-training on a huge dataset.

In Fig 7, we compare the training and evaluation time of Residual Shuffle-Exchange (RSE), Shuffle-Exchange (SE) and Universal Transformer (UT) networks using configurations that reach their best test accuracy. We use the

Table 1. Accuracy on LAMBADA word prediction task

Model	Learnable parameters (M)	Test accuracy (%)
Random word from passage (Paperno et al., 2016)	-	1.6
Gated-Attention Reader (Chu et al., 2017)	unknown	49.0
Neural Shuffle-Exchange network (Freivalds et al., 2019)	33	52.28
Residual Shuffle-Exchange network (this work)	11	54.34
Universal Transformer (Dehghani et al., 2018)	152	56.0
GPT-2 (Radford et al., 2019)	1542	63.24
Human performance (Chu et al., 2017)	-	86.0

official Universal Transformer and Shuffle-Exchange implementations and measure the time for one training and evaluation step on a single sequence. For the Universal Transformer, we use its base configuration with 152M learnable parameters. Shuffle-Exchange and Residual Shuffle-Exchange networks have 384 feature maps and 2 Beneš blocks, with total parameter count 33M and 11M, respectively. We evaluate sequence lengths that fit in the 11GB of GPU memory. Residual Shuffle-Exchange network works faster and can be evaluated on 4x longer sequences than Shuffle-Exchange network and 128x longer sequences than the Universal Transformer.

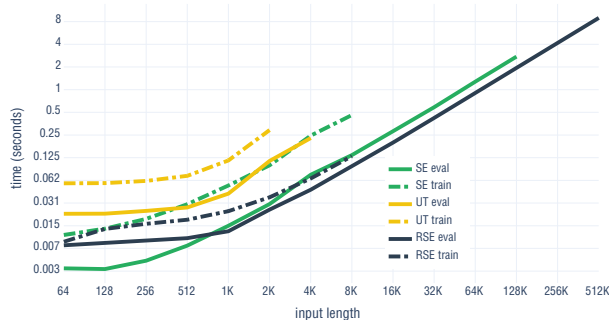

Figure 7. Evaluation and training time on different input lengths (log-scale).

5.3. MusicNet

The music transcription dataset MusicNet (Thickstun et al., 2016) consists of 330 classical music recordings paired with the midi transcriptions of their notes. The total length of the recordings is 34 hours, and it features 11 different instruments. The task is to classify what notes are being played at each time step given the waveform. As multiple notes can be played at the same time, this is a multi-label classification task.

The dataset does not provide a separate validation set, so we split off 6 recordings from the training set as in (Trabelsi et al., 2018) and use them for validation. Like in (Yang et al.,

2019), the waveform is downsampled from 44.1 kHz to 11 kHz. To perform classification, regularly spaced windows of a given length are extracted from the waveform, and we predict all the notes that are being played at the midpoint of the window.

We use an RSE model with two Beneš blocks with 192 feature maps. We experimentally found this to be the best configuration. To increase the training speed, we prepend two strided convolutions in front of that, see analysis of other options below. To obtain the note predictions, we use the element in the middle of the sequence output by the RSE model, linearly transform it to the 128 values, one for each note pitch, and apply the sigmoid-cross-entropy loss function to perform multi-label classification.

We add an additional term to the loss function which predicts the notes played at regularly spaced intervals with stride 128 in the input sequence. This term is used only during training. The term is added because using only the middle element in the loss function seems to lead to lower accuracy in predicting the beginning and the end of the notes. The loss for these additional predictions is calculated in the same way as for the middle element. We find that adding this term to the loss function improves the training speed and the final accuracy of the model. For example, without adding this loss term we achieve 76.84%, which is by 1.18% lower than with the added term.

We train the model for 800k iterations which corresponds to approximately 8 epochs. We found this value by examining the training dynamics on the validation set.

For evaluating the model, we use the average precision score (APS) which is the area under the precision-recall curve. This metric is well suited to prediction tasks with imbalanced classes and is suggested for the MusicNet dataset in the original paper (Thickstun et al., 2016).

We train the model on different window sizes ranging from 128 to 8192, see Fig. 8. We find that larger windows invariably lead to better accuracy. The best APS score of 78.02% is obtained on length 8192 that is by 3.8% better than the previous state of the art achieved by Complex Transformer

Residual Shuffle-Exchange Networks

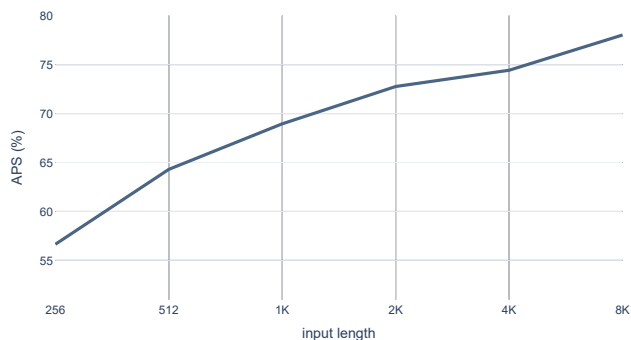

Figure 8. MusicNet accuracy depending on the window size.

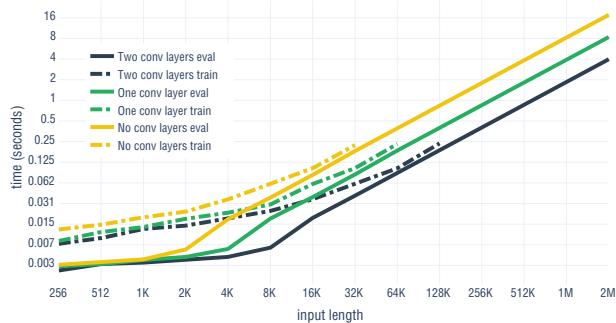

Figure 9. Training and evaluation speed (log-scale) depending on the prepended convolution count on the MusicNet task.

Table 2. Performance on the MusicNet music transcription dataset

Model	Learnable parameters (M)	APS (%)
cgRNN (Wolter and Yao, 2018)	2.36	53.00
Deep Real Network (Trabelsi et al., 2018)	10.00	69.80
Deep Complex Network (Trabelsi et al., 2018)	17.14	72.90
Complex Transformer (Yang et al., 2019)	11.61	74.22
Residual Shuffle-Exchange network (this work)	3.06	78.02

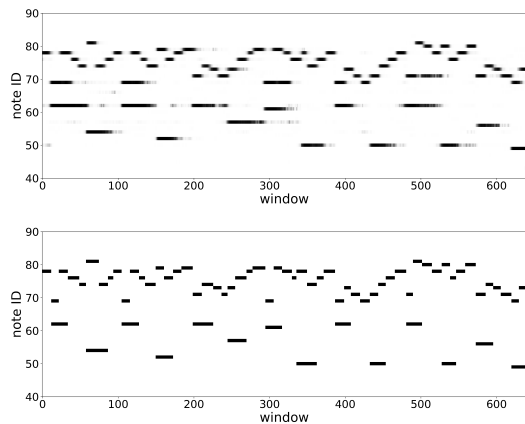

Figure 10. Top picture shows the predictions of our model on the test set. Bottom picture shows the corresponding labels.

(Yang et al., 2019), see Table 2 for the comparison with other works. For a visualisation of the notes predicted with window size 8192 and the correct labels, see Fig. 10. The notes are generally well predicted but their start and end time are smoothed out, especially for the lower pitches. The predicted note shading represents the classification confidence. In real applications an appropriate threshold should be applied to get note duration.

We have tested how prepending convolutions impact the speed and accuracy of the model. Table 3 shows the obtained

Table 3. Accuracy (APS) depending on the number of convolutional layers on length 1024

Convolutional layer count	APS (%)
0	69.29
1	69.57
2	68.95
3	67.39

accuracy on window size 1024 for a different number of convolutions. We find that one convolution gives the best results, although the differences are small. We chose to use two convolutions for a good balance between speed and accuracy.

Fig. 9 shows the training and evaluation speed of the model depending on the number of convolutions. We use the batch size of one example in this test to see the sequence length limit our model can be trained and tested on a single GPU. The training lines stop at the length at which the model does not fit in the GPU memory anymore. Testing lines reach a 2M technical limitation of our implementation. Increasing the number of convolution layers improves training and testing speed, and the version with two convolutions can be trained on sequences up to length 128K.

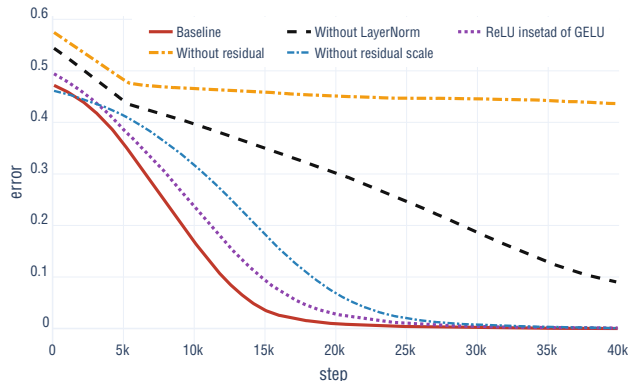

Figure 11. Ablation experiments. The plot shows test error on the multiplication task length 128 vs training step.

5.4. Ablation study

We have chosen the multiplication task as a showcase for the ablation study. It is a hard task which challenges every aspect of the model and performance differences are clearly observable. We use a model with 2 Beneš blocks, 192 feature maps and train it on length 128. We consider the following simplifications of the proposed architecture:

- removing LayerNorm (without LayerNorm)
- using ReLU instead of GELU
- removing the residual connection; the last equation of RSU becomes $[o_1, o_2] = c$ (without residual)
- setting the residual weight parameter $\sigma(S)$ to a constant 1 instead of a learnable parameter; the equation becomes $[o_1, o_2] = i + h \odot c$ (without residual scale)

We can see in Fig. 11 that the proposed baseline performs the best. Versions without residual connection or without normalization do not work well. Residual weight parameter and GELU non-linearity give a smaller contribution to the model’s performance.

In Fig. 12, we investigate the effect of the RSU middle layer size on the performance. Parameter count and speed of the model is directly proportional to the middle layer size; therefore, we want to select the smallest size, which gives a good performance. By default, we use $2m$ feature maps where m is the number of feature maps of the model. Versions with half as many or twice as many middle maps are explored. We see that a larger middle map count gives a better performance. We consider the choice of $2m$ inner maps a good compromise between performance and parameter count.

We have performed ablation experiments also for LAM-BADA and MusicNet tasks with similar conclusions, but the differences are much less pronounced.

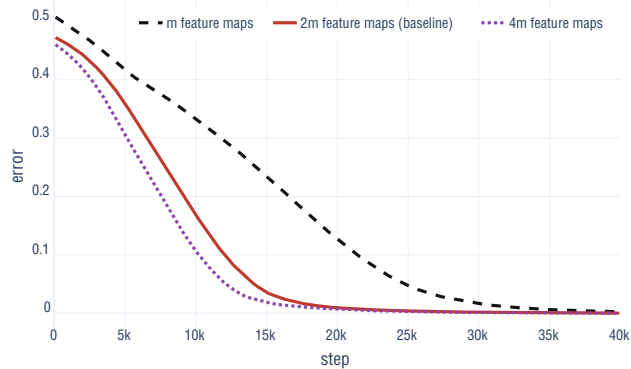

Figure 12. Test error depending on the middle layer size (m is the number of feature maps of the model).

6. Conclusions

We have introduced a new Residual Shuffle-Exchange neural network model that outperforms the previous one in terms of accuracy, speed and simplicity. It has $O(n \log n)$ complexity and enables processing of sequences up to length 2 million where standard methods, like attention, fail. We have shown how to combine the model with strided convolutions that increases its speed and sequence length that can be processed.

The proposed model achieves state-of-the-art accuracy to recognize musical notes directly from the waveform – a task where the ability to process long sequences is crucial. Notably, our architecture uses significantly fewer parameters than the previously best models for this task.

By providing an alternative version of the Switch Unit, we have established that the interconnection structure of the Shuffle-Exchange network is the key to the power of the network, not a particular implementation of the switching mechanism. Our experiments confirm the Residual Shuffle-Exchange network as a useful building block for long sequence processing applications.

Acknowledgements

We would like to thank the IMCS UL Scientific Cloud for the computing power and Leo Trukšāns for the technical support. This research is funded by the Latvian Council of Science, project No. lzp-2018/1-0327.

References

- Al-Rfou, R., D. Choe, N. Constant, M. Guo, and L. Jones 2018. Character-level language modeling with deeper self-attention. *arXiv preprint arXiv:1808.04444*.
- Ba, J. L., J. R. Kiros, and G. E. Hinton

2016. Layer normalization. *arXiv preprint arXiv:1607.06450*.
- Benetos, E., S. Dixon, Z. Duan, and S. Ewert
2019. Automatic music transcription: An overview. *IEEE Signal Processing Magazine*, 36:20–30.
- Child, R., S. Gray, A. Radford, and I. Sutskever
2019. Generating long sequences with sparse transformers. *arXiv preprint arXiv:1904.10509*.
- Cho, K., B. Van Merriënboer, C. Gulcehre, D. Bahdanau, F. Bougares, H. Schwenk, and Y. Bengio
2014. Learning phrase representations using RNN encoder-decoder for statistical machine translation. *arXiv preprint arXiv:1406.1078*.
- Chu, Z., H. Wang, K. Gimpel, and D. McAllester
2017. Broad context language modeling as reading comprehension. In *Proceedings of the 15th Conference of the European Chapter of the Association for Computational Linguistics: Volume 2, Short Papers*, Pp. 52–57. ACL (Association for Computational Linguistics).
- Clark, C. and M. Gardner
2017. Simple and effective multi-paragraph reading comprehension. *arXiv preprint arXiv:1710.10723*.
- Dai, Z., Z. Yang, Y. Yang, W. W. Cohen, J. Carbonell, Q. V. Le, and R. Salakhutdinov
2019. Transformer-xl: Attentive language models beyond a fixed-length context. *arXiv preprint arXiv:1901.02860*.
- Dally, W. J. and B. P. Towles
2004. *Principles and practices of interconnection networks*. Elsevier.
- Dehghani, M., S. Gouws, O. Vinyals, J. Uszkoreit, and Ł. Kaiser
2018. Universal transformers. *arXiv preprint arXiv:1807.03819*.
- Devlin, J., M.-W. Chang, K. Lee, and K. Toutanova
2018. Bert: Pre-training of deep bidirectional transformers for language understanding. *arXiv preprint arXiv:1810.04805*.
- Freivalds, K. and R. Liepins
2018. Improving the neural GPU architecture for algorithm learning. *The ICML workshop Neural Abstract Machines & Program Induction v2 (NAMPI 2018)*.
- Freivalds, K., E. Ozoliņš, and A. Šostaks
2019. Neural shuffle-exchange networks – sequence processing in $O(n \log n)$ time. In *Advances in Neural Information Processing Systems 32*, Pp. 6626–6637. Curran Associates, Inc.
- Gehring, J., M. Auli, D. Grangier, D. Yarats, and Y. N. Dauphin
2017. Convolutional sequence to sequence learning. In *Proceedings of the 34th International Conference on Machine Learning*, D. Precup and Y. W. Teh, eds., volume 70 of *Proceedings of Machine Learning Research*, Pp. 1243–1252. PMLR.
- Graves, A., G. Wayne, and I. Danihelka
2014. Neural Turing machines. *arXiv preprint arXiv:1410.5401*.
- Graves, A., G. Wayne, M. Reynolds, T. Harley, I. Danihelka, A. Grabska-Barwińska, S. G. Colmenarejo, E. Grefenstette, T. Ramalho, J. Agapiou, et al.
2016. Hybrid computing using a neural network with dynamic external memory. *Nature*, 538(7626):471.
- Grefenstette, E., K. M. Hermann, M. Suleyman, and P. Blunsom
2015. Learning to transduce with unbounded memory. In *Advances in Neural Information Processing Systems 28*, C. Cortes and Lee D.D. et al., eds., Pp. 1828–1836. Curran Associates, Inc.
- Guo, Q., X. Qiu, P. Liu, Y. Shao, X. Xue, and Z. Zhang
2019. Star-transformer. *arXiv preprint arXiv:1902.09113*.
- Hendrycks, D. and K. Gimpel
2016. Gaussian error linear units (gelus). *arXiv preprint arXiv:1606.08415*.
- Hochreiter, S. and J. Schmidhuber
1997. Long short-term memory. *Neural computation*, 9(8):1735–1780.
- Huang, C.-Z. A., A. Vaswani, J. Uszkoreit, I. Simon, C. Hawthorne, N. Shazeer, A. M. Dai, M. D. Hoffman, M. Dinculescu, and D. Eck
2019. Music transformer. In *International Conference on Learning Representations*.
- Joulin, A. and T. Mikolov
2015. Inferring algorithmic patterns with stack-augmented recurrent nets. In *Advances in Neural Information Processing Systems 28*, C. Cortes and Lee D.D. et al., eds., Pp. 190–198. Curran Associates, Inc.
- Kaiser, Ł. and S. Bengio
2016. Can active memory replace attention? In *Advances in Neural Information Processing Systems 29*, D. Lee and Luxburg U.V. et al., eds., Pp. 3781–3789. Curran Associates, Inc.
- Kaiser, Ł. and I. Sutskever
2015. Neural GPUs learn algorithms. *arXiv preprint arXiv:1511.08228*.

- Kalchbrenner, N., I. Danihelka, and A. Graves
2015. Grid long short-term memory. *arXiv preprint arXiv:1507.01526*.
- Kant, N.
2018. Recent advances in neural program synthesis. *arXiv preprint arXiv:1802.02353*.
- Kitaev, N., Ł. Kaiser, and A. Levskaya
2020. Reformer: The efficient transformer. *arXiv preprint arXiv:2001.04451*.
- Liu, L., H. Jiang, P. He, W. Chen, X. Liu, J. Gao, and J. Han
2019. On the variance of the adaptive learning rate and beyond. *arXiv preprint arXiv:1908.03265*.
- Mikolov, T., E. Grave, P. Bojanowski, C. Puhrsch, and A. Joulin
2018. Advances in pre-training distributed word representations. In *Proceedings of the Eleventh International Conference on Language Resources and Evaluation (LREC 2018)*, N. Calzolari and Choukri, Khalid et al., eds. European Language Resources Association (ELRA).
- Paperno, D., G. Kruszewski, A. Lazaridou, Q. N. Pham, R. Bernardi, S. Pezzelle, M. Baroni, G. Boleda, and R. Fernández
2016. The lambada dataset: word prediction requiring a broad discourse context. In *Proceedings of the 54th Annual Meeting of the Association for Computational Linguistics (Volume 1: Long Papers)*, Pp. 1525–1534. ACL (Association for Computational Linguistics).
- Radford, A., J. Wu, R. Child, D. Luan, D. Amodei, and I. Sutskever
2019. Language models are unsupervised multitask learners.
- Thickstun, J., Z. Harchaoui, and S. Kakade
2016. Learning features of music from scratch. *arXiv preprint arXiv:1611.09827*.
- Trabelsi, C., O. Bilaniuk, Y. Zhang, D. Serdyuk, S. Subramanian, J. F. Santos, S. Mehri, N. Rostamzadeh, Y. Bengio, and C. Pal
2018. Deep complex networks. [arxiv:1705.09792](https://arxiv.org/abs/1705.09792).
- van den Oord, A., S. Dieleman, H. Zen, K. Simonyan, O. Vinyals, A. Graves, N. Kalchbrenner, A. W. Senior, and K. Kavukcuoglu
2016. Wavenet: A generative model for raw audio. In *SSW - the 9th ISCA Speech Synthesis Workshop, Sunnyvale, CA, USA, 2016*, P. 125.
- Vaswani, A., N. Shazeer, N. Parmar, J. Uszkoreit, L. Jones, A. N. Gomez, Ł. Kaiser, and I. Polosukhin
2017. Attention is all you need. In *Advances in Neural Information Processing Systems 30*, I. Guyon and Luxburg U.V. et al., eds., Pp. 5998–6008. Curran Associates, Inc.
- Vinyals, O., M. Fortunato, and N. Jaitly
2015. Pointer networks. In *Advances in Neural Information Processing Systems 28*, C. Cortes and Lee D.D. et al., eds., Pp. 2692–2700. Curran Associates, Inc.
- Wolter, M. and A. Yao
2018. Complex gated recurrent neural networks. In *Advances in Neural Information Processing Systems*, Pp. 10536–10546.
- Xu, J., X. Sun, Z. Zhang, G. Zhao, and J. Lin
2019. Understanding and improving layer normalization. In *Advances in Neural Information Processing Systems*, Pp. 4383–4393.
- Yang, M., M. Q. Ma, D. Li, Y.-H. H. Tsai, and R. Salakhutdinov
2019. Complex transformer: A framework for modeling complex-valued sequence. *arXiv preprint arXiv:1910.10202*.
- Yu, F. and V. Koltun
2015. Multi-scale context aggregation by dilated convolutions. *arXiv preprint arXiv:1511.07122*.
- Zaremba, W., T. Mikolov, A. Joulin, and R. Fergus
2016. Learning simple algorithms from examples. In *International Conference on Machine Learning*, Pp. 421–429.
- Zaremba, W. and I. Sutskever
2015. Reinforcement learning neural Turing machines-revised. *arXiv preprint arXiv:1505.00521*.