

# Inter-Slice Mobility Management in 5G: Motivations, Standard Principles, Challenges and Research Directions

Muhammad Mohtasim Sajjad, *Member, IEEE*, Carlos J. Bernardos, Dhammika Jayalath, *Senior Member, IEEE*, and Yu-Chu Tian, *Senior Member, IEEE*

**Abstract**—As a prime feature of 5G networks, Network Slicing has opened up several new avenues of research. Mobility management in a network-sliced environment, in particular, introduces new and complex research challenges. In a network-sliced environment, user mobility has to be managed not only among different base stations or access technologies, but also among different slices. This motivates the need for new mobility management solutions, which, by convention, are required to be standards-compliant. This article investigates the problem of inter-slice mobility from the perspective of 3GPP standards for 5G. The existing 3GPP standard procedures only enable users to change (or switch) slices. They lack formal mechanisms for session continuation among slices, and thus need to be enhanced to achieve seamless inter-slice mobility or handovers. In this direction, we identify some open challenges as well as some potential research directions towards developing efficient, comprehensive and 3GPP compliant inter-slice mobility management solutions.

**Index Terms**—5G, Inter-Slice Mobility Management, Network Slicing, Service-based Architecture, Machine Learning.

## I. INTRODUCTION

The ability to support slicing i.e., the support for various virtual networks over the same physical network infrastructure is among the fundamental requirements of the 5G networks. Network Slicing enables simultaneous provisioning of diverse service types such as Ultra-Reliable Low Latency Communications (URLLC), Vehicle-to-Everything (V2X), Massive Internet-of-Things (MIoT), as well as the conventional enhanced Mobile Broadband (eMBB) over the same network. The state-of-the-art virtualization technologies such as Software-Defined Networking (SDN) and Network Functions Virtualization (NFV) are identified as key enablers for network slicing. These technologies facilitate convenient and dynamic deployment of network slices.

A network slice, in general, is expected to deliver the user/service requirements consistently all the time (especially for URLLC and V2X use cases). However, the users with active sessions may wish to change their slices as their preferences or requirements change over time. The slice-owners may also wish to move users out of a slice, thus causing these users to look for alternate slices to connect to. Hence, in a network-sliced environment, handovers among different slices (i.e., inter-slice handovers) are also expected, in addition to the traditional horizontal and vertical handovers. An example network-sliced environment depicting these different forms of handovers is shown in Figure 1.

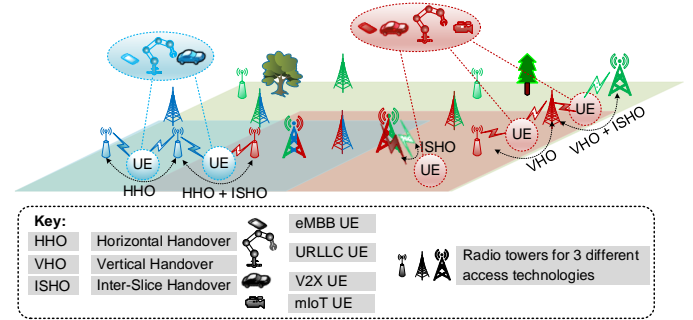

Fig. 1: An example Network-sliced mobility environment showing different handover types of UEs. The shown slices (and the UEs) belong to one of the four service types i.e., URLLC, V2X, eMBB, and MIoT.

Inter-slice handover is a new form of handover. As shown in Figure 1, unlike the horizontal handovers, the inter-slice handover may not always be event-triggered. Also, it may not always involve the physical mobility of the User Equipment (UE), as is the case with vertical handovers. Hence, the users/UEs belonging to any service type may require to undergo inter-slice handovers for a number of reasons. Some of these are listed and described in Table 1, which include varying slice characteristics both at Core Network and Radio Access Network (RAN), service/application requirements, user/slice owner preferences etc. As indicated in the table, these causes may either force the network to trigger the inter-slice handover (i.e., Network triggered inter-slice handover) or the user/UE itself (i.e., UE-Initiated inter-slice handover). As a general principle, a user/UE will undergo inter-slice handover only to a slice belonging to the same service type. This may occur as a standalone event or as a result of a horizontal or a vertical handover as shown in Figure 1.

The dynamics of inter-slice handovers among slices of a specific service type may be significantly divergent from others. While there will be similarities, different slices will have their own service type-specific inter-slice handover dynamics as well. For example, most of the MIoT UEs will be stationary or will have very low mobility [9], so the inter-slice handovers due to horizontal handovers are less likely. Such scenarios, however, are expected to occur routinely for UEs belonging to, for instance, eMBB or V2X use cases. Likewise, the

Main Causes	Potential Inter-Slice Handover Triggers	Description	Typical Inter-Slice Handover Initiation point
Slice-specific Conditions	Access network conditions	The Received Signal Strength (RSS), Bit Error Rate (BER), Signal-to-Interference and Noise Ratio (SINR), link capacity at access network may deteriorate over time forcing a user to switch to an alternate slice.	UE-Initiated
	Slice delay	Slices employing different user-plane topologies with large number of user-plane nodes may cause high queueing and link delays causing higher end-to-end slice delays.	UE-Initiated
	Slice bandwidth	The bandwidth availability of a slice may change over time (e.g., due to high bandwidth utilization by users).	Network triggered
	Reliability	The error rate from a slice might increase (e.g., due to congestion or some node failures) which would reduce the reliability of the connection, causing the user to switch slices.	UE-Initiated
	Slice Stability	Due to potential hardware or software faults or some security attacks, a slice might not be able to provide consistent communication services, and exhibit an unstable performance.	UE-Initiated/ Network triggered
Service/Appl. Requirements	QoS requirements	A slice may not be able to meet the desired QoS of an ongoing application/service, in terms of Bandwidth, Delay, Jitter, Error Rate, Throughput, Data rates.	UE-Initiated
Slice owners Preferences	Slice stress/load	A popular slice might attract a large number of users which results in high utilization of available slice resources, causing high stress/load on slice. The slice can thus enforce inter-slice mobility for some users, e.g., for better power/energy or other resources management, or to serve their premium user base better.	Network triggered
	Subscription policies	A network slice may provide services to a user under specific subscription policies. Once a user consumes its allowed services, it may be forced out from the slice.	Network triggered
	Pricing/Billing	A network slice may discontinue its services to a user, if a user runs out of its available credit.	Network triggered
Intra-/Inter-Technology Handovers	Horizontal Handover	A mobile user moving into a new subnet might move out of the coverage of its current slice as well, which would require it to undergo an inter-slice handover.	UE-Initiated
	Vertical handover	The user's choice to switch to another access technology might also require it to undergo inter-slice handover if its desired access technology is not supported by the current slice.	UE-Initiated
User Preferences	Monetary Costs	Different slices might offer same services at different costs.	UE-Initiated
	Slice Isolation Level	Some users might prefer slices with higher degree of isolation which is characterized by the level of resource/infrastructure sharing with other slices.	UE-Initiated
	Slice Security	Slices with strong security mechanisms might be preferred by some users.	UE-Initiated
	Slice Policies	Slice owners would employ their own specific policies. Users would prefer slices which offer flexible policies rather than strict rules. Some slice owners might offer only limited services for users, based on their policies. This might also encourage users to look for alternate slices to connect to.	UE-Initiated

TABLE I: Example Inter-Slice Handover Causes

core URLLC and V2X slices are expected to be deployed closer to users/UEs through edge technologies to achieve lower network delays. This may not always be the case for eMBB or MIIoT UEs. Without specifically addressing inter-slice mobility dynamics of specific service types, our work in this article focuses on the fundamentals of inter-slice handovers.

It has been recognized that mobility management in a sliced network requires new protocols [9], [10]. However, in the contemporary research, only limited efforts have been made on the problem of inter-slice mobility management [1], [2]. These solutions, however, only give basic guidelines, and do not provide any specific framework or a protocol for inter-slice mobility management.

In general, for the inter-slice mobility management solutions to be of practical significance, they ought to comply standard practices. In this regard, these solutions are expected to comply with the standard principles of the network slicing framework specified by the 3rd Generation Partnership Project (3GPP). The 3GPP network slicing framework is based on a novel Service-based Architecture (SBA), which is seen as a first practical step towards realization of network slicing. This framework, however, does not provide any specific support for inter-slice handovers (i.e., the session continuation support among slices is not available). As a result, when a user/UE wishes to change its slice, its ongoing session at its current slice is released before it can be re-established over an alternate slice. Hence, in order to realize the seamless

inter-slice handover support, the existing framework requires enhancements.

In this direction, this article aims to identify technical gaps and requirements, as well as corresponding research directions to achieve efficient inter-slice handover support in 3GPP SBA. Hereinafter, we use the term inter-slice switching to refer to the process of user/UE switching (or changing) slices without session transfer among slices. The terms inter-slice handover and inter-slice mobility management are used interchangeably to refer to the process when a user/UE moves among slices with seamless continuation of its ongoing session.

In the following, we first discuss the standard principles and relevant mechanisms which constitute inter-slice switching in SBA. Several possible forms of inter-slice switching are discussed, along with an overview of one example case which provides a detailed explanation of these standard principles. Finally, we discuss some challenges, and the corresponding research directions which can be pursued for developing comprehensive and efficient inter-slice handover solutions within the standard framework of the 3GPP SBA.

## II. INTER-SLICE SWITCHING IN 3GPP SBA - STANDARD PRINCIPLES

A network slice, according to 3GPP, is a logical network which has specific network characteristics and capabilities. It is essentially a set of virtual/logical network functions (NFs) which run on top of network resources such as compute,

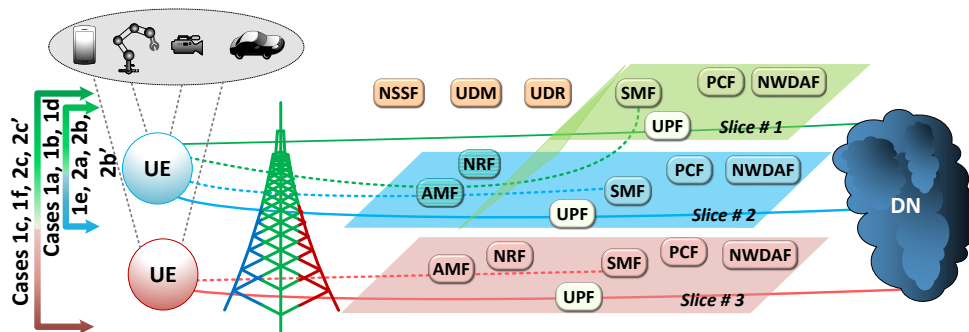

Fig. 2: A Representation of Network-Sliced 3GPP SBA (based on [5]). Possible forms (or cases) of Inter-Slice Switching are also shown, which are discussed in Section III.

storage and networking. These NFs may be slice-specific, or shared among slices. The AMF (Access and Mobility Management Function) is a prominent such example, among other NFs, as shown in Figure 2.

In order to communicate over a slice, a UE first requires to register itself with the slice. For this purpose, the UE carries out a “Registration” process with the AMF. The AMF, in addition to Registration Management, is also responsible for access control and mobility management for UE. After successfully registering with the slice, the UE can establish a session with an external Data Network (DN) through this slice. The traffic exchanges between the UE and DN is in the form of PDUs (Protocol Data Units) and the communication session among them is termed as a PDU session. The UE can request Session Management Function (SMF) for the PDU session establishment (as well as PDU session release when required). Apart from UE’s session management, SMF also configures and controls the User Plane Functions (UPFs), which are the data plane entities at the core network where the actual traffic routing and forwarding takes place. Some other prominent NFs are given in Table II.

#### Principles for Inter-Slice Switching

A network slice in SBA is commonly identified through an identifier namely S-NSSAI (Single Network Slice Selection Assistance Information). The 3GPP standard procedures for the management of network slices usually deal with a set of S-NSSAIs, which form an *NSSAI*. Every PLMN (Public Land Mobile Network) domain supports a specific set of S-NSSAIs for users which is termed as *Configured NSSAI*. A user can have subscriptions to multiple S-NSSAIs in a network. An S-NSSAI with which a user has an active subscription with, is

termed as a *Subscribed S-NSSAI*. A user, however, can only avail services of a slice (e.g., establishing a PDU session to a DN over it), if the network allows connectivity over the slice. A set of slices to which the user is allowed to connect to at any given time is termed as *Allowed NSSAI*. A user can access a maximum of eight slices at most, simultaneously.

In principle, a UE can only switch to a slice if it is present in its *Allowed NSSAI*. If a user wishes to access a slice to which it is subscribed to, but is currently not present in the *Allowed NSSAI*, it can request the network to include the slice in the *Allowed NSSAI* by sending a *Requested NSSAI* through a “Registration” process (discussed later). A *Requested NSSAI* refers to the set of slices (S-NSSAIs) requested by the UE to be included in the *Allowed NSSAI*. If a user/UE does not specifically request the network for a particular slice (S-NSSAI), the network serves the UE via at least one *default S-NSSAI* (slice), which is chosen from the *Subscribed S-NSSAIs* of the user/UE.

The inter-slice switching may or may not require a modification in the current *Allowed NSSAI*. The modification of *Allowed NSSAI* can be done either by UE or the network slice itself, by carrying out certain procedures. The modification of *Allowed NSSAI* is followed by the PDU Session Management process, which includes the release of PDU session from the current slice and its (re-)establishment with the desired target slice. Specifically, the procedures for modification of *Allowed NSSAI* involve mechanisms such as the UE Configuration Update and Registration, while session management involves PDU Session Release and PDU Session (Re-)Establishment procedures.

**UE Configuration Update:** This procedure is normally used by the network to update certain configurations at UE,

Symbol	Notation	Function
NSSF	Network Slice Selection Function	Supports appropriate network slice selection, as well as the AMF Selection for UE.
PCF	Policy Control Function	Provides policy information which govern the functionality of both AMF and SMF.
UDM	Unified Data Management	Stores and provides subscription data (e.g., access and mobility subscription data, and the session management subscription data)
UDR	Unified Data Repository	Provides Storage and retrieval of structured data for UDM, PCF etc.
NWDAF	Network Data Analytics Function	Provides network data analytics information of a slice to another network function (e.g., PCF, NSSF).

TABLE II: Functional Description of NFs in SBA.

for instance, Access and Mobility Management related parameters. It can also be used to modify the *Allowed NSSAI* of the UE. In the context of inter-slice switching, the network/AMF can force the removal of a slice from *Allowed NSSAI* with which the user/UE has an active session with. This will force the user/UE to connect to an alternate slice.

**Registration (with or without AMF relocation):** Registration is normally required when a user/UE wishes to access network services or moves out of a registration area. It can also be used by a user/UE to request modification of the *Allowed NSSAI*. In the context of inter-slice switching, the UE can carry out Registration in order to acquire the desired slice(s) (S-NSSAI(s)) in the *Allowed NSSAI*. It is worth mentioning that during a Registration process, the AMF re-location may also take place (i.e., a new AMF may be chosen) if the current AMF is unable to serve all slices in the new *Allowed NSSAI*.

**UE-/Network-Initiated PDU Session Release:** Through this procedure, the network or the UE can initiate the release of an ongoing PDU session. In the context of inter-slice switching, the network may initiate the PDU Session Release to indicate the unavailability of a slice. This procedure at the network slice can be initiated by the AMF, SMF or PCF. With the PDU Session Release procedure, all configurations (e.g., QoS configurations) as well as resources associated with the PDU Session are released. Such resources include, the allocated IP address, any UPF resources, and RAN resources.

**PDU Session Establishment:** In the context of inter-slice switching, the user/UE carries out PDU Session Establishment to (re-)establish its ongoing session over an alternate slice. The user/UE can decide to initiate this procedure itself if it wishes to switch to another slice. The user/UE may also carry out this procedure if it is forced by the network to switch slices

(i.e., through the aforementioned UE Configuration Update or the PDU Session Release procedures).

### III. FORMS OF INTER-SLICE SWITCHING IN 3GPP SBA

Depending on the availability of the candidate S-NSSAI and the PDU Session status, both the UE-initiated inter-slice switching and the Network-triggered inter-slice switching can occur in several forms. These forms accordingly define the order of sequence of their respective protocol operations. We refer to these forms as different *cases* of inter-slice switching. The sequence of the involved procedures in each case is shown in Figure 3, and are briefly described below.

#### Network-Triggered Inter-Slice Switching

Cases 1a to 1f represent the network-triggered inter-slice switching. Cases 1a, 1b and 1c are triggered through UE Configuration Update, while Cases 1d, 1e and 1f are triggered by enforcing the PDU Session Release. An AMF-initiated PDU Session Release procedure is also carried out in Cases 1a, 1b and 1c, as a result of UE Configuration Update (Figure 3). This is because the AMF determines that a slice with an active PDU session with UE is now unavailable in its *Allowed NSSAI*.

In Cases 1a and 1d, the UE is able to choose a suitable alternate slice from the already available *Allowed NSSAI*. The UE can then (re-)establish its session over this slice. In other cases, however, the UE does not have a suitable alternate slice in the *Allowed NSSAI* to connect to. Therefore, it chooses the alternate slice (S-NSSAI) from the *Configured NSSAI/Subscribed S-NSSAI(s)* and performs Registration to obtain its desired slice (S-NSSAI) in *Allowed NSSAI*. The

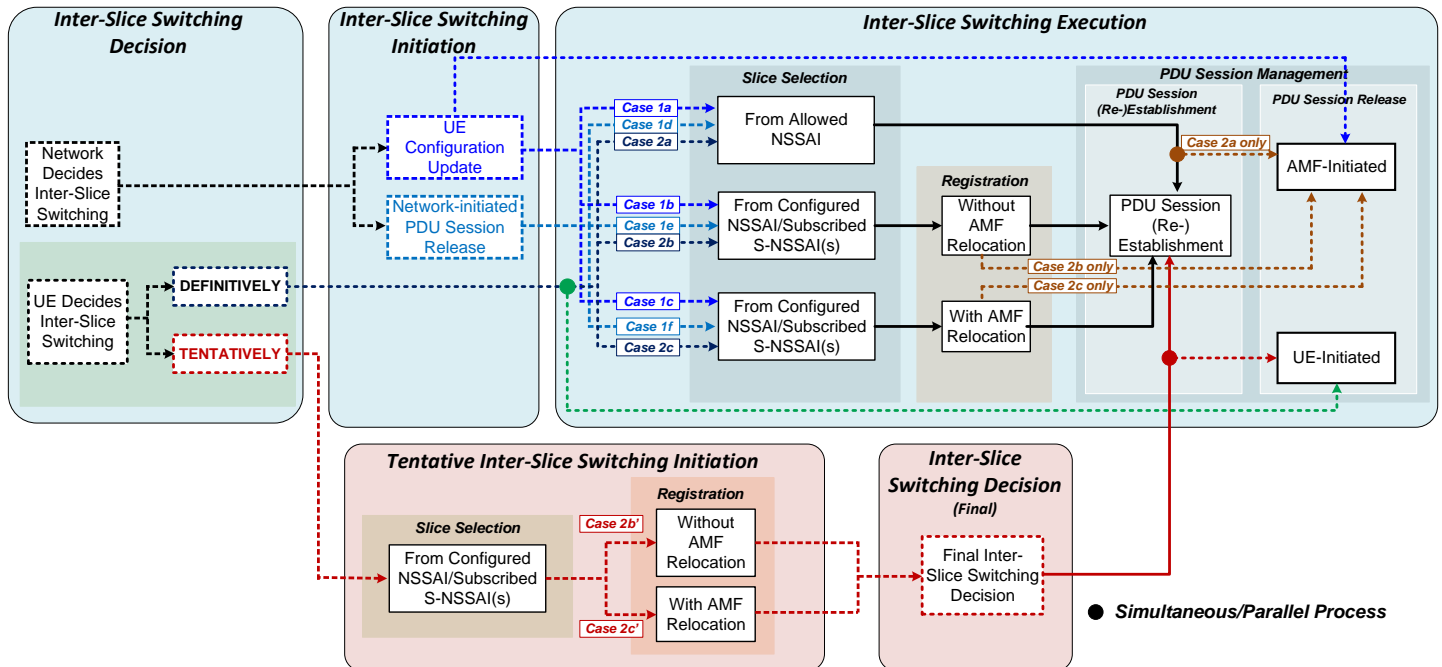

Fig. 3: Inter-Slice Switching cases

Registration process in Cases 1b and 1e does not require the AMF relocation/(re-)selection. However, for Cases 1c and 1f, Registration process involves the AMF Relocation as well.

#### *UE-Initiated Inter-Slice Switching*

In contrast to the network-triggered inter-slice switching, the UE can possibly choose to initiate the inter-slice switching *tentatively* or *definitively*. Cases 2a to 2c shown in Figure 3 are *definitive* cases, while the Cases 2b' and 2c' are *tentative* cases. In *definitive* cases, the user/UE decides to definitely switch slices (i.e., it decides to leave the current slice definitely regardless of whether a suitable alternate slice is available in *Allowed NSSAI*, e.g., due to very high costs or zero throughput etc.). In *tentative* cases, the user does not experience any unacceptable issues with the current slice. It simply attempts to obtain a possible alternate slice (S-NSSAI) in *Allowed NSSAI* through Registration (e.g., for same service guarantees at lower costs). It makes the final decision to switch slices only after the successful completion of the Registration process.

It is worth mentioning that in the *tentative* cases, the modification to *Allowed NSSAI* during Registration does not remove the currently active slice (S-NSSAI) from the *Allowed NSSAI*. So, whether the Registration process completes successfully or not, the PDU session of UE over the current slice will remain active, until the user/UE makes the final decision to switch slices.

In the *definitive* Case 2a, the user/UE decides to switch to an alternate slice that is already present in *Allowed NSSAI*. In Cases 2b and 2c, the UE first performs Registration to obtain its target slice (S-NSSAI) in *Allowed NSSAI*. For Case 2b, the Registration does not require the AMF Relocation. For Case 2c, the Registration does require AMF Relocation. During Registration, as soon as the AMF learns that the modification to *Allowed NSSAI* has led to the unavailability of a currently active slice, it initiates the PDU Session Release procedure over this slice as well. Notably, such an initiation of PDU Session Release during Registration does not occur in case of Network-triggered cases. This is because in each of those cases the PDU Session Release is already executed before Registration either explicitly (i.e. for Cases 1d, 1e & 1f) or on successful completion of the UE Configuration Update procedure.

The *tentative* cases 2b' and 2c' also follow the same sequence of procedures as 2b and 2c, however, unlike in Cases 2b and 2c, the Registration in Cases 2b' and 2c' does not remove the currently active slice (S-NSSAI) from the *Allowed NSSAI*. This allows the user/UE to make the final decision to switch slices after the Registration process completes successfully.

#### *An Example Inter-Slice Switching Case:*

In order to develop a deeper understanding of the underlying standard principles of the aforementioned cases, we now summarize the operation of an example inter-slice switching case. Case 1b is chosen for this purpose as its operation encompasses most major procedures common in some other

cases as well. The signalling sequence of Case 1b is shown in Figure 4.

In Case 1b, the AMF triggers inter-slice switching by removing the currently active slice (S-NSSAI) of UE from its *Allowed NSSAI*. The UE's session is released and it stops receiving traffic from the current slice. The AMF communicates the modified *Allowed NSSAI* to the UE via UE Configuration Update Command message. The UE however chooses its alternate slice from *Configured NSSAI/Subscribed S-NSSAI(s)*. The UE then sends Registration Request containing its *Requested NSSAI* to AMF. The AMF verifies the *Requested NSSAI* through UE's subscription information, which it retrieves from UDM. The NSSF can also assist the AMF for *Requested NSSAI* verification, and provisioning of new *Allowed NSSAI*. After verification, the AMF sends the new *Allowed NSSAI* with UE's desired slices (S-NSSAI(s)) in Registration Accept message.

The UE is now ready to start the PDU Session (Re-)Establishment with its desired slice (S-NSSAI). It sends the PDU Session Establishment Request to SMF via AMF. The AMF may first select a suitable SMF, especially if the operator deploys multiple SMFs (e.g., for load balancing). The SMF in order to process the UE's request, first retrieves the Session Management (SM) subscription data from UDM. After verifying the UE's SM subscription, the SMF performs a number of functions before accepting the UE's request. These include, (a). Initiation of UE authentication/authorization with external DN. (b). PCF selection and retrieval of the policy information (e.g., charging and QoS information) from PCF. This information is enforced by SMF during the PDU Session Management. (c). UPF(s) selection, which handle UE's traffic at data plane. N4 sessions establishment with UPF(s) also takes place which allow SMF-UPF interaction. During the N4 sessions establishment, the SMF provides UPF(s) with packet detection, enforcement, and reporting rules for handling the UE's traffic at the data plane. (d) IP address allocation, which (assuming IPv6 addressing) is advertised to UE later on when the PDU Session Establishment completes successfully. (e). Communicating the SM parameters to UE and RAN.

The successful configuration of the SM parameters at UE and RAN also marks completion of the PDU session establishment process. The SMF eventually provides the IPv6 Address Configuration information (i.e., an IPv6 Prefix) and sends it to the UE via the UPF(s). The uplink/downlink packet delivery from/to the UE subsequently starts over the new slice.

#### IV. TOWARDS SEAMLESS INTER-SLICE MOBILITY – KEY CHALLENGES AND RESEARCH DIRECTIONS:

Seamless inter-slice mobility management is an essential capability in a sliced mobile network. It allows users/UEs a choice to continue their session over an alternate slice if the conditions of current slice are not satisfactory or desirable any more. To achieve seamless inter-slice handovers, it is imperative that the existing inter-slice switching mechanisms are enhanced with seamless inter-slice handover support mechanisms. In this vein, we discuss some requirements and challenges, as well as some research directions as follows.

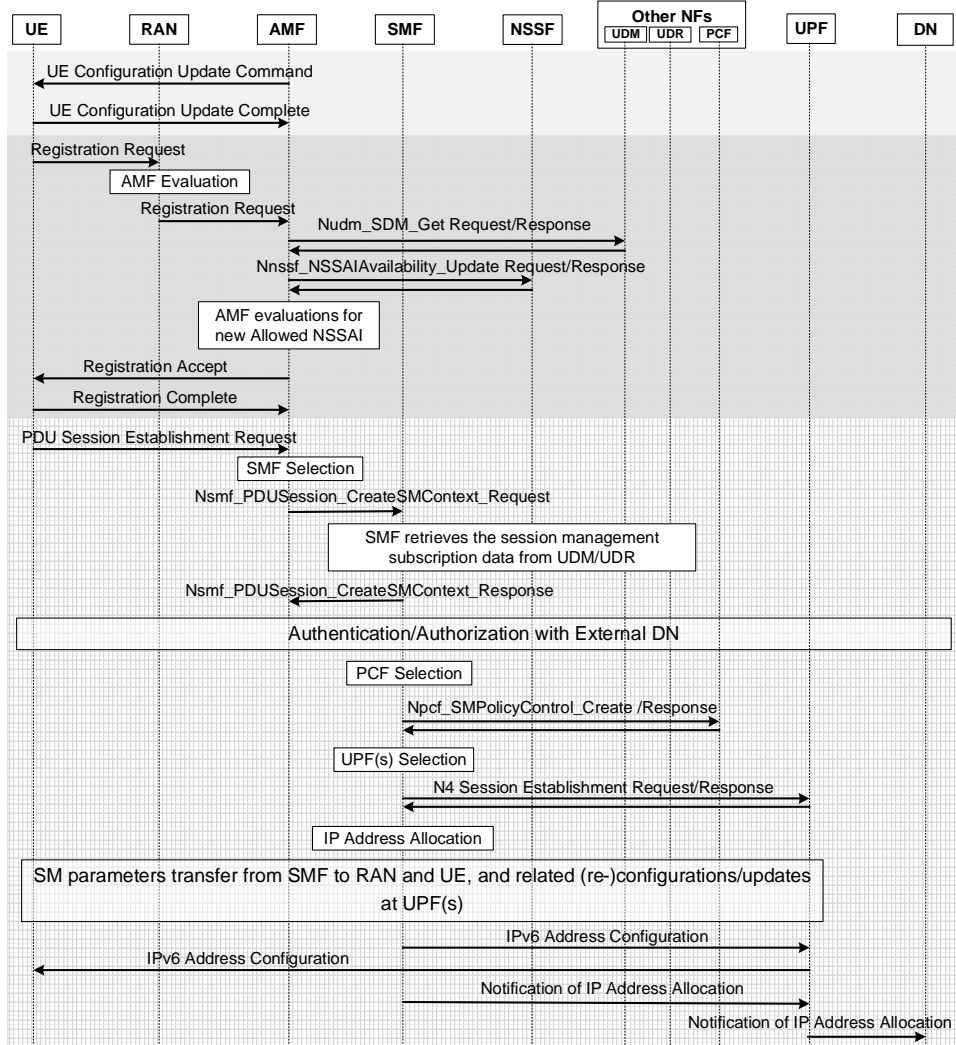

Fig. 4: Signalling Sequence for Inter-Slice Switching operation (Case 1b)

**Session Continuity:** “Session Continuation” or “Session Transfer” among slices is a fundamental requirement to achieve inter-slice handovers. The existing 3GPP specifications support PDU Session Transfers between 3GPP and non-3GPP systems, as well as the Evolved Packet System (EPS) and 5G system [4]. Similar approaches can be adopted and extended/enhanced towards supporting session transfer among slices as well. Another potential approach could be to adopt the concept of gateway Apps [2] or gateways nodes at the data plane of each slice. However, it is worth noting that the session continuation mechanisms are also required to take into account the necessary establishment of resources and configurations at new slice (both at Core and RAN). The corresponding release of these resources and configurations in the previous slice is also required. In the present specifications, the establishment of resources and configurations occurs during the PDU Session Establishment and their release, through the PDU Session Release procedures respectively.

**Timely Slice Selection and Inter-Slice Handover Triggering:** For an efficient inter-slice handover operation, it is critical

that a suitable target slice is decided in a timely manner, and handover is triggered to the target slice at a precise instance (i.e. neither too early, nor too late). Both these are complex challenges considering the dynamics of a network-sliced environment. This becomes evident especially if the target slices are orchestrated based on dynamically shared resources. A powerful approach to address these challenges is to use Data Analytics, which paves a way to apply Machine Learning techniques. To this end, the network data analytics information from the standard NWDAF function may be utilized. To ensure the selection of a suitable target slice, key parameters, characteristics, prevailing conditions of the candidate slices, and the preferences of users and operators may be taken under consideration. In this direction, certain machine learning algorithms from supervised learning, and reinforcement learning may be used, which are now being increasingly employed to address such problems [6], [7], [11].

**Inter-Slice Handover Information Gathering and Exchange:** An efficient slice selection and inter-slice handover decision-making requires timely and up-to-date information



on the prevailing conditions of the target/candidate slices. The NWDAF function can receive various events information from other core NFs such as AMF, SMF, and PCF. Information/Data retrieval from other NFs such as UDM/UDR, NSSF, NEF (Network Exposure Function), NRF (Network Repository Function) [3], is also possible. The standard NWDAF operation, however, is confined only to core NFs of the slice. For efficient inter-slice handover decision mechanisms, RAN information from target slices as well as from UE are also necessary. For this purpose, enhancement to the existing network data analytics framework may be required. In fact, some recent works (e.g., [8]) have already proposed some solutions in this direction which focus on extending the existing network data analytics framework beyond the core NFs to encompass the RAN as well.

**Inter-Slice Handover Preparation:** The inter-slice handover process can be optimized through handover preparation mechanisms. For example, prediction mechanisms could be put in place to predict the imminent deterioration of slice conditions. This can support the proactive initiation of inter-slice handovers as opposed to the reactive triggering of handover as the conditions have deteriorated already. In this direction again, Machine Learning techniques can be applied [6], [7].

**Inter-Slice Handover Scheduling:** The inter-slice handover process may not be a desirable operation for users/UEs belonging to URLLC and V2X service types. In this regard, the user/UEs or slice owners may *schedule* the inter-slice handover process at specific intervals only. For instance, when a vehicle (a V2X UE) is stationary or moving in a non-congested area, or when a robotic device at a remote factory (a URLLC UE) is performing a non-critical task. Again, the NWDAF can provide necessary intelligence to determine the suitable interval for scheduling the inter-slice handover.

**Managing Inter-Slice Handovers with Horizontal and Vertical Handovers:** A critical mobility management scenario in a network-sliced environment occurs when an inter-slice handover is triggered as a result of a horizontal or a vertical handover (as depicted in Figure 1). Both these scenarios are prone to high latencies as they require simultaneous management of a user/UE's mobility to a new subnet or access technology and to a new slice. Hence, in addition to the standalone inter-slice handover solutions, integrated solutions would be needed which can collectively handle horizontal/vertical handovers alongside inter-slice handovers within a unified mobility management framework.

## V. CONCLUSIONS

Representing a paradigm shift in network engineering, Network Slicing requires new protocols for network management. In particular, mobility management in a network-sliced environment requires new and efficient solutions. This article has investigated the problem of inter-slice mobility from the 3GPP standards perspective. It has provided a thorough overview of the 3GPP standard principles which constitute a user/UEs inter-slice switching. Although specific support for session continuation among slices is not given in current specifications, the existing inter-slice switching mechanisms do

provide a baseline for developing efficient and comprehensive inter-slice mobility management solutions within the 3GPP standards framework. In this regard, we have highlighted some prospective research directions, and in particular, the potential of “data analytics” and “machine learning” techniques towards achieving seamless inter-slice mobility in 5G networks.

## REFERENCES

- [1] H. Zhang, N. Liu, X. Chu, K. Long, A. Aghvami and V. C. M. Leung, “Network Slicing Based 5G and Future Mobile Networks: Mobility, Resource Management, and Challenges,” in *IEEE Communications Magazine*, vol. 55, no. 8, pp. 138-145, Aug. 2017.
- [2] F. Z. Yousaf et al., “Network slicing with flexible mobility and QoS/QoE support for 5G Networks,” 2017 IEEE International Conference on Communications Workshops (ICC Workshops), Paris, 2017, pp. 1195-1201.
- [3] System Architecture for the 5G System; Stage 2 Release 15, 3GPP Std. TS 23.501, Rev. V15.4.0, Dec. 2018.
- [4] Procedures for the 5G System; Stage 2 Release 15, 3GPP Std. TS 23.502, Rev. V15.4.1, Jan. 2019.
- [5] F. Mademann, “System architecture milestone of 5G Phase 1 is achieved,” 3GPP.org. [https://www.3gpp.org/news-events/3gpp-news/1930-sys\\_architecture](https://www.3gpp.org/news-events/3gpp-news/1930-sys_architecture) (accessed Dec. 1, 2019)
- [6] J. Xie et al., “A Survey of Machine Learning Techniques Applied to Software Defined Networking (SDN): Research Issues and Challenges,” in *IEEE Communications Surveys & Tutorials*, vol. 21, no. 1, pp. 393-430, First quarter 2019.
- [7] F. Musumeci et al., “An Overview on Application of Machine Learning Techniques in Optical Networks,” in *IEEE Communications Surveys & Tutorials*, vol. 21, no. 2, pp. 1383-1408, Second quarter 2019.
- [8] E. Pateromichelakis et al., “End-to-End Data Analytics Framework for 5G Architecture,” in *IEEE Access*, vol. 7, pp. 40295-40312, 2019.
- [9] X. Foukas, G. Patounas, A. Elmokashfi and M. K. Marina, “Network Slicing in 5G: Survey and Challenges,” in *IEEE Communications Magazine*, vol. 55, no. 5, pp. 94-100, May 2017.
- [10] X. Li et al., “Network Slicing for 5G: Challenges and Opportunities,” in *IEEE Internet Computing*, vol. 21, no. 5, pp. 20-27, 2017.
- [11] V. P. Kafle, P. Martinez-Julia and T. Miyazawa, “Automation of 5G Network Slice Control Functions with Machine Learning,” in *IEEE Communications Standards Magazine*, vol. 3, no. 3, pp. 54-62, September 2019