

Keyless Covert Communication via Channel State Information

Hassan ZivariFard, Matthieu R. Bloch, *Senior Member, IEEE*, and Aria Nosratinia, *Fellow, IEEE*

Abstract

We consider the problem of covert communication over a state-dependent channel when the channel state is available either non-causally, causally, or strictly causally, either at the transmitter alone, or at both transmitter and receiver. Covert communication with respect to an adversary, called “warden,” is one in which, despite communication over the channel, the warden’s observation remains indistinguishable from an output induced by innocent channel-input symbols. Covert communication involves fooling an adversary in part by a proliferation of codebooks; for reliable decoding at the legitimate receiver the codebook uncertainty is typically removed via a shared secret key that is unavailable to the warden. In contrast to previous work, we do not assume the availability of a shared key at the transmitter and legitimate receiver. Instead, shared randomness is extracted from the channel state in a manner that keeps it secret from the warden, despite the influence of the channel state on the warden’s output. When channel state is available at the transmitter and receiver, we derive the covert capacity region. When channel state is only available at the transmitter, we derive inner and outer bounds on the covert capacity. We provide examples for which the covert capacity is positive with knowledge of channel state information but is zero without it.

I. INTRODUCTION

Covert communication refers to scenarios in which reliable communication over a channel must occur while simultaneously ensuring that a separate channel output at a node called the warden has a distribution identical to that induced by an innocent channel symbol [1]–[5]. It is known that in a point-to-point Discrete Memoryless Channel (DMC) without state, the number of bits that can be reliably and covertly communicated over n channel transmissions scales at most as $O(\sqrt{n})$.¹ This result has motivated the study of other models in which positive rates are achievable, e.g., when the transmitter and the receiver share on the order of $\sqrt{n} \log(n)$ key bits [1]. Of particular relevance to the present work, Lee *et al.* [6] considered the problem of covert communication over a state-dependent channel in which the channel state is known either causally or non-causally to the transmitter but unknown to the receiver and the warden. The authors derived the covert capacity when the transmitter and the receiver share a sufficiently long secret key, as well as a lower bound on the minimum secret key length needed to achieve the covert capacity. In [7], the present authors derive an achievable rate region for the case that non-causal Channel

H. ZivariFard and A. Nosratinia are with Department of Electrical Engineering, The University of Texas at Dallas, Richardson, TX, USA. M. R. Bloch is with School of Electrical and Computer Engineering, Georgia Institute of Technology, Atlanta, GA, USA. E-mail: hassan@utdallas.edu, matthieu.bloch@ece.gatech.edu, aria@utdallas.edu.

The material in this paper was presented in part at IEEE Information Theory Workshop 2019, Visby, Gotland, Sweden.

The work of H. ZivariFard and A. Nosratinia is supported by National Science Foundation (NSF) grant number 1514050. The work of M. R. Bloch is supported by National Science Foundation (NSF) grant number 1527387.

¹Except for the special case when the output distribution (at the warden) induced by the innocent symbol is a convex combination of the output distributions generated by the other input symbols.

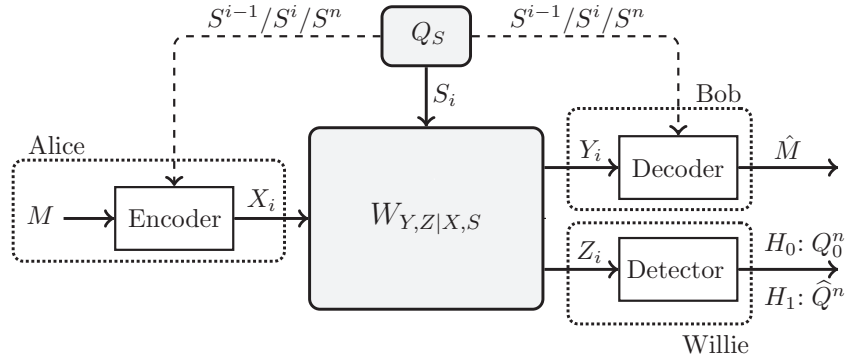

Fig. 1. Model of covert communication over state-dependent DMC when channel state is available at both the transmitter and the receiver. State Information (CSI) is available at both the transmitter and the receiver while there is no shared key between the legitimate terminals and they extract the secret key from the channel state information. Covert communication over a compound channel in which the object to be masked is the state of the compound channel was also studied by Salehkalaibar *et al.* [8]. Given the presence of a channel state, one may wonder if covert communication with positive rate is possible *without* requiring an external secret key. In particular, several works demonstrated the benefits of exploiting common randomness and channel states to generate secret keys. For instance, the problem of stealth secret key generation from correlated sources was studied by Lin *et al.* [9], [10] and covert secret key generation was studied by Tahmasbi and Bloch [11], [12].

The usefulness of exploiting states for secrecy has been extensively investigated in the context of state-dependent wiretap channels. A discrete memoryless wiretap channel with random states known non-causally at the transmitter was first studied by Chen and Han Vinck [13], who established a lower bound on the secrecy capacity based on a combination of wiretap coding with Gel'fand-Pinsker coding. Generally speaking, coding schemes with CSI outperform those without CSI because perfect knowledge of the CSI not only enables the transmitter to beamform its signal toward the legitimate receiver but also provides a source of common randomness from which to generate a common secret key and enhance secrecy rates. Khisti *et al.* [14] studied the problem of secret key generation from non-causal channel state available at the transmitter and established inner and outer bounds on the secret key capacity. Chia and El Gamal [15] studied a wiretap channel in which the state information is available causally at both transmitter and receiver, proposing a scheme in which the transmitter and the receiver extract a weakly secret key from the state and protect the confidential message via a one-time-pad driven with the extracted key (see also [16] and [17]). Han and Sasaki [18] subsequently extended this result to achieve strong secrecy. Goldfeld *et al.* [19] proposed a superposition coding scheme for the problem of transmitting a semantically secure message over a state-dependent channel while the channel state is available non-causally at the transmitter.

This paper studies covert communication over a state-dependent discrete memoryless channel with channel state available either non-causally, causally, or strictly causally, either at both the transmitter and the receiver or at the transmitter alone (see Fig. 1). One of the main contributions of this work is to show that the channel state can be used to simultaneously and efficiently accomplish two necessary tasks: using the channel state for a Shannon strategy or Gel'fand-Pinsker coding, while also extracting a shared secret key at the two legitimate terminals to resolve the multiple codebooks that are necessary for covert communication. Secret key extraction from channel states replaces the external secret key in other models, thus generalizing and expanding the applicability of covert communication.

We characterize the exact covert capacity when CSI is available at both the transmitter and the receiver, and derive inner and outer bounds on the covert capacity when channel state information is only available at the transmitter. For some channel models for which the covert capacity is zero without channel state information, we show that the covert capacity is positive with channel state information. The code constructions behind our proofs combine different coding mechanisms, including channel resolvability for covertness, channel randomness extraction for key generation, and Gel'fand-Pinsker coding for state-dependent channels. The key technical challenge consists in properly combining these mechanisms to ensure the overall covertness of the transmission through block-Markov chaining schemes.

II. PRELIMINARIES

Throughout this paper, random variables are denoted by capital letters and their realizations by lower case letters. The set of ϵ -strongly jointly typical sequences of length n , according to $P_{X,Y}$, is denoted by $\mathcal{T}_\epsilon^{(n)}(P_{X,Y})$. For convenience, typicality will reference the random variables rather than the distribution, e.g., we write $\mathcal{T}_\epsilon^{(n)}(X, Y)$ or $\mathcal{T}_\epsilon^{(n)}(X|Y)$. Superscripts denote the dimension of a vector, e.g., X^n . The integer set $\{1, \dots, M\}$ is denoted by $\llbracket 1, M \rrbracket$, $X_{[i:j]}$ indicates the set $\{X_i, X_{i+1}, \dots, X_j\}$, and $X_{\sim i}^n$ denotes the vector X^n except X_i . The cardinality of a set is denoted by $|\cdot|$. The total variation between probability mass functions (pmfs) is defined as $\|P - Q\|_1 = \sum_x |P(x) - Q(x)|$ and the Kullback-Leibler (KL) divergence between pmfs is defined as $\mathbb{D}(P||Q) = \sum_x p(x) \log \frac{P(x)}{Q(x)}$. The support of a probability distribution P is denoted by $\text{supp}(P)$. The n -fold product distribution constructed from the same distribution P is denoted $P^{\otimes n}$.

Consider a discrete memoryless state-dependent channel as shown in Fig. 1. \mathcal{X} is the channel input, \mathcal{Y} and \mathcal{Z} are the channel outputs at the legitimate receiver and the warden, respectively. Let $x_0 \in \mathcal{X}$ be an innocent symbol corresponding to the absence of communication with the receiver. We assume that the channel state is independent and identically distributed (i.i.d.) and drawn according to P_S . Define

$$Q_0(\cdot) = \sum_{s \in \mathcal{S}} Q_S(s) W_{Z|X,S}(\cdot|x_0, s), \quad (1)$$

$$Q_Z(\cdot) = \sum_{s \in \mathcal{S}} \sum_{x \in \mathcal{X}} Q_S(s) P_{X|S}(x|s) W_{Z|X,S}(\cdot|x, s) \quad (2)$$

and let $Q_0^{\otimes n} = \prod_{i=1}^n Q_0$ and also let $Q_Z^{\otimes n} = \prod_{i=1}^n Q_Z$. We define a non-negative cost $g(x)$ for every channel input $x \in \mathcal{X}$. The average cost of an input sequence $x^n \in \mathcal{X}^n$ is $g(x^n) = \frac{1}{n} \sum_{i=1}^n g(x_i)$. The channel state can be available non-causally, causally, or strictly causally at both the transmitter and the receiver, but not to the warden. An $(|\mathcal{M}|, n)$ code consists of an encoder that maps (M, S^n) to $X^n \in \mathcal{X}^n$ and a decoder at the receiver that maps Y^n to $\widehat{M} \in \mathcal{M}$. The code is assumed known to all parties and the objective is to design a code that is both reliable and covert. The code is defined to be reliable if the probability of error $P_e^{(n)} = \mathbb{P}(\widehat{M} \neq M)$ goes to zero when $n \rightarrow \infty$. The code is covert if the warden cannot determine whether communication is happening (hypothesis H_1) or not (hypothesis H_0). The probabilities of false alarm (warden deciding H_1 when H_0 is true) and missed detection (warden deciding H_0 when H_1 is true), are denoted by α_n and β_n , respectively. An uninformed, random decision by the warden satisfies $\alpha_n + \beta_n = 1$, which is the benchmark for covertness. When the channel carries communication, the warden's channel output distribution is denoted P_{Z^n} , and the optimal hypothesis test by the warden satisfies $\alpha_n + \beta_n \geq 1 - \sqrt{\mathbb{D}(P_{Z^n} || Q_0^{\otimes n})}$ [20]. Therefore, to show that the communication is covert, it

suffices to show that $\mathbb{D}(P_{Z^n}||Q_0^{\otimes n}) \rightarrow 0$. Note that $\text{supp}(Q_0) = \mathcal{Z}$ otherwise $\mathbb{D}(P_{Z^n}||Q_0^{\otimes n}) \rightarrow \infty$. Consequently, our goal is to design a sequence of $(2^{nR}, n)$ codes such that

$$\lim_{n \rightarrow \infty} P_e^{(n)} \rightarrow 0, \quad (3)$$

$$\lim_{n \rightarrow \infty} \mathbb{D}(P_{Z^n}||Q_0^{\otimes n}) \rightarrow 0, \quad (4)$$

$$\lim_{n \rightarrow \infty} g(X^n) \leq G. \quad (5)$$

where G is a constraint on cost per codeword. We define the covert capacity as the supremum of all achievable covert rates and denote it by $C_{\text{NC-TR}}$ for non-causal CSI available at both the transmitter and the receiver, $C_{\text{NC-T}}$ for non-causal CSI only available at the transmitter, $C_{\text{C-TR}}$ for causal CSI available at both the transmitter and the receiver, $C_{\text{C-T}}$ for causal CSI available just at the transmitter, $C_{\text{SC-TR}}$ and $C_{\text{SC-T}}$ for strictly causal CSI available at both the transmitter and the receiver and strictly causal CSI only available at the transmitter, respectively.

III. CHANNEL STATE INFORMATION AVAILABLE AT TRANSMITTER AND RECEIVER

A. Causal or Non-causal Channel State Information

Theorem 1. *The covert capacity of the DMC $W_{Y,Z|S,X}$ with causal or non-causal CSI available at the transmitter and the receiver is*

$$C_{\text{NC-TR}} = C_{\text{C-TR}} = \max \mathbb{I}(X; Y|S), \quad (6)$$

where the maximum is over distributions $Q_S P_{X|S} W_{Y,Z|X,S}$ such that $\mathbb{E}[g(X)] \leq G$, $Q_Z = Q_0$, which are the marginal distributions defined in (1) and (2), and

$$\mathbb{H}(S|Z) \geq \mathbb{I}(X; Z|S) - \mathbb{I}(X; Y|S). \quad (7)$$

The achievability is proved by block Markov encoding, rate splitting, and treating CSI as a time-sharing sequence. We design a block Markov coding scheme in which the transmitter not only generates a key from S^n but also selects its codeword according to S^n . The proof is available in Appendix A.

Remark 1. *Theorem 1 captures the idea that the key rate extracted from the channel state ($\mathbb{H}(S|Z)$) should be at least as large as the Right Hand Side (RHS) of (7). When the warden's channel is a degraded version of the main channel, the transmitter and the receiver do not need a shared key because (7) is automatically satisfied.*

B. Strictly Causal Channel State Information

We now consider the case in which strictly causal channel state information is available at both the transmitter and the receiver. Even though *strictly* causal channel state information is more restricted, it is still useful because the shared randomness can still be used to mislead the warden.

Theorem 2. *The covert capacity of the DMC $W_{Y,Z|S,X}$ with strictly causal CSI available at the transmitter and the receiver is*

$$C_{\text{SC-TR}} = \max \mathbb{I}(X; Y|S), \quad (8)$$

Table 1
JOINT PROBABILITY DISTRIBUTION OF X, S

| | | |
|------------------|-----------------------------|---------|
| $X \backslash S$ | 0 | 1 |
| 0 | α | β |
| 1 | $1 - \alpha - \beta - \eta$ | η |

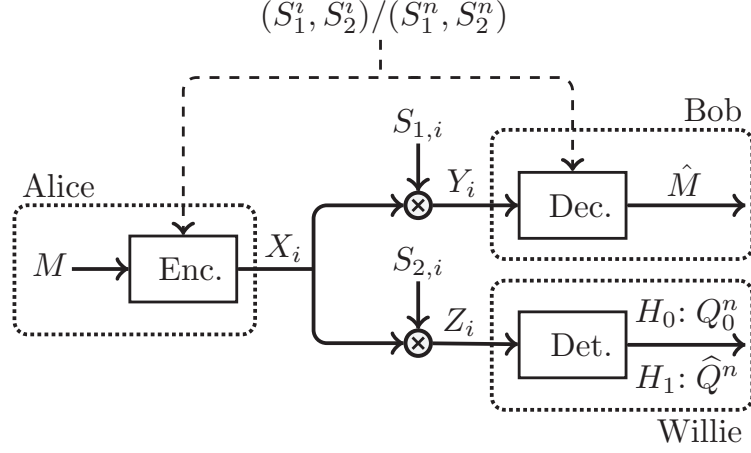

Fig. 3. Binary symmetric channel with multiplicative CSI at the transmitter and the receiver

$$Q_Z(z = 0) = P_{X,S}(x = 0, s = 0) + P_{X,S}(x = 1, s = 1) = \alpha + \eta, \quad (13)$$

$$Q_S(s = 0) = P_{X,S}(x = 0, s = 0) + P_{X,S}(x = 1, s = 0) = \alpha + \beta. \quad (14)$$

Therefore $Q_Z = Q_S$ implies that

$$Q_Z(z = 0) = Q_S(s = 0) \Rightarrow \alpha + \eta = \alpha + \beta \Rightarrow \eta = \beta. \quad (15)$$

Therefore,

$$\begin{aligned} \max_{Q_S P_{X|S}} \mathbb{H}(X|S) &= \max_{\substack{(\alpha, \beta) \\ \zeta = \alpha + \beta}} \left[-\alpha \log \frac{\alpha}{\alpha + \beta} - (1 - \alpha - 2\beta) \log \frac{1 - \alpha - 2\beta}{1 - \alpha - \beta} \right. \\ &\quad \left. - \beta \log \frac{\beta}{\alpha + \beta} - \beta \log \frac{\beta}{1 - \alpha - \beta} \right]. \end{aligned} \quad (16)$$

Considering $P_S(s = 0) = \zeta = \alpha + \beta$ and substituting $\beta = \alpha - \zeta$ in (16) results in

$$\begin{aligned} \max_{Q_S P_{X|S}} \mathbb{H}(X|S) &= \max_{\alpha} \left[-\alpha \log \frac{\alpha}{\zeta} - (1 + \alpha - 2\zeta) \log \frac{1 + \alpha - 2\zeta}{1 - \zeta} \right. \\ &\quad \left. - (\zeta - \alpha) \log \frac{\zeta - \alpha}{\zeta} - (\zeta - \alpha) \log \frac{\zeta - \alpha}{1 - \zeta} \right]. \end{aligned} \quad (17)$$

Since entropy is a continuous concave function, the maximizer of $\mathbb{H}(X|S)$ is found at the root of the first derivative of (17). This root is $\alpha = \zeta^2$, resulting in $\max \mathbb{H}(X|S) = \mathbb{H}(S)$. \square

B. Binary Multiplicative State

Consider a channel in which X, Y, Z, S_1 , and S_2 are all binary and S_1 and S_2 have a joint distribution with parameters $P(S_1 = i, S_2 = j) = p_{i,j}$, for $i, j \in \{0, 1\}$ and the innocent symbol is $x_0 = 0$ (See Fig. 3). The law of the channel is

$$Y = X \otimes S_1, \quad Z = X \otimes S_2. \quad (18)$$

Proposition 2. *The covert capacity of the DMC depicted in Fig. 3 with causal or non-causal CSI available at the transmitter and the receiver is*

$$C_{\text{NC-TR}} = C_{\text{C-TR}} = p_{1,0}. \quad (19)$$

The condition in $\mathbb{H}(S|Z) \geq \mathbb{I}(X; Z|S) - \mathbb{I}(X; Y|S)$ is satisfied and therefore no key is needed to achieve the covert capacity.

Proof. In Theorem 1, by substituting $S = (S_1, S_2)$,

$$\begin{aligned} C_{\text{NC-TR}} = C_{\text{C-TR}} &= \max_{\substack{P_{X|S_1, S_2}, \\ Q_Z = Q_0}} [\mathbb{I}(X; Y|S_1, S_2)] \\ &= \max_{\substack{P_{X|S_1, S_2}, \\ Q_Z = Q_0}} \left[\sum_{i=0}^1 \sum_{j=0}^1 p_{i,j} \mathbb{I}(X; Y|S_1 = i, S_2 = j) \right] \\ &\stackrel{(a)}{=} \max_{P_{X|S_1, S_2}} \left[\mathbb{I}(X; Y|s_1 = 1, s_2 = 0) \right] \\ &= \max_{P_{X|S_1, S_2}} \left[p_{1,0} \mathbb{H}(X|s_1 = 1, s_2 = 0) \right] \\ &= p_{1,0}. \end{aligned} \quad (20)$$

(a) holds because when $S_1 = 0$, communication is prohibited because Y is annihilated, and when $S_2 = 1$, we have $Z = X$ therefore $P_X = Q_Z = Q_0$, and once again there can be no communication.

Also, Z always equal to zero implies that $\mathbb{I}(X; Z|S) \leq \mathbb{H}(Z) = 0$ and therefore the condition $\mathbb{H}(S|Z) \geq \mathbb{I}(X; Z|S) - \mathbb{I}(X; Y|S)$ is satisfied, so no key is needed to achieve the covert capacity region. \square

V. CHANNEL STATE INFORMATION AT THE TRANSMITTER

Fig. 4 depicts covert communication with channel state available at the transmitter (but not the receiver). Whenever transmitted symbols must be generated one-by-one at transmission time, controlling the cost of a codeword is much more difficult. Therefore, we revert to an average cost constraint of the form:

$$\lim_{n \rightarrow \infty} \mathbb{E}_{\mathcal{C}, M, S^n} [g(X^n)] \leq G. \quad (21)$$

This is of course not an issue when the state is demonstrably unhelpful and therefore is not used, e.g., the strictly causal channel state. In such cases, the codeword cost constraint can once again be applied.

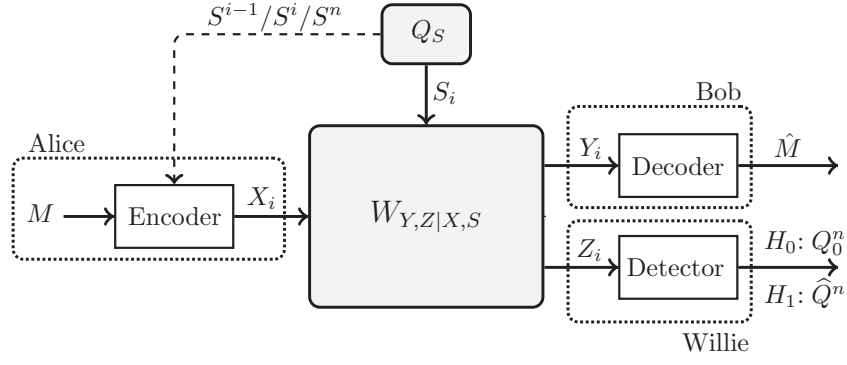

Fig. 4. Model of covert communication over state-dependent DMC when CSI is only available at the transmitter

A. Non-Causal CSI

Theorem 3. *The covert capacity of the DMC $W_{Y,Z|S,X}$ with non-causal CSI only available at the transmitter is lower-bounded*

$$C_{\text{NC}} \geq \max [\mathbb{I}(U; Y) + \mathbb{I}(V; U, Y) - \max\{\mathbb{I}(U; S) + \mathbb{I}(V; S), \mathbb{I}(U, V; S)\}], \quad (22)$$

where the maximum is over distributions of the form $Q_S P_{U|S} P_{V|S} P_{X|U,S} W_{Y,Z|X,S}$, such that $\mathbb{E}[g(X)] \leq G$, $Q_Z = Q_0$, and

$$\mathbb{I}(U; Y) + \mathbb{I}(V; U, Y) \geq \max\{\mathbb{I}(U, S; Z) - \mathbb{H}(S|U, V), \mathbb{I}(U; Z), \mathbb{I}(U; Z) + \mathbb{I}(S; Z) - \mathbb{H}(S|V)\}. \quad (23)$$

The proof is by block Markov encoding, Gel'fand-Pinsker coding for sending the message according to CSI, and Wyner-Ziv coding for secret key generation. We design a block Markov coding scheme in which the transmitter not only generates a key from S^n but also selects its codeword according to S^n by using a likelihood encoder [21]. Proof details are available in Appendix C.

Theorem 4. *The covert capacity of the DMC $W_{Y,Z|S,X}$ with non-causal CSI only available at the transmitter is lower-bounded*

$$C_{\text{NC}} \geq \max [\mathbb{I}(U; Y) - \mathbb{I}(U; S) - \mathbb{H}(S|U, Y)], \quad (24)$$

where the maximum is over distributions of the form $Q_S P_{U|S} P_{X|U,S} W_{Y,Z|X,S}$, such that $\mathbb{E}[g(X)] \leq G$, $Q_Z = Q_0$, which are the marginal distributions defined in (1) and (2), and

$$\mathbb{I}(U; Y) - \mathbb{H}(S|U, Y) \geq \mathbb{I}(U, S; Z) - \mathbb{H}(S|U). \quad (25)$$

The proof is available in Appendix E and is similar to the proof of Theorem 3 in the usage of block Markov and Gel'fand-Pinsker coding. The differences are outlined below.

Remark 2. *Theorems 3 and 4 introduce two achievable schemes for the same problem (non-causal CSI at transmitter). Theorem 3 generates a key whose rate is smaller but can be controlled due to the introduction of an extra auxiliary random variable. The generated secret key rate for Theorem 4 is larger but cannot be varied, therefore the communication overhead, required for reconciliation, can sometimes make this method inferior to Theorem 3, even though it is more efficient in key extraction.*

Theorem 5. *The covert capacity of the DMC $W_{Y,Z|S,X}$ with non-causal CSI at the transmitter is upper-bounded*

$$C_{\text{NC-T}} \leq \max [\mathbb{I}(U; Y) - \mathbb{I}(U; S)], \quad (26)$$

where the maximum is over distributions of the form $Q_S P_{U|S} P_{X|U,S} W_{Y,Z|X,S}$, such that $\mathbb{E}[g(X)] \leq G$, $Q_Z = Q_0$, which are the marginal distributions defined in (1) and (2), and

$$\mathbb{H}(S|Z) \geq \mathbb{I}(U; S, Z) - \mathbb{I}(U; Y). \quad (27)$$

Proof. The proof for (26) is similar to that of [6, Theorem 3]. To prove (27) we have

$$\begin{aligned} nR &\stackrel{(a)}{\geq} n\mathbb{I}(\tilde{X}, \tilde{S}; \tilde{Z}) - n\mathbb{H}(\tilde{S}) \\ &\stackrel{(b)}{\geq} n\mathbb{I}(\tilde{U}, \tilde{S}; \tilde{Z}) - n\mathbb{H}(\tilde{S}) \end{aligned} \quad (28)$$

where (a) follows by the steps in (90) and (b) follows from the Markov chain $U - (X, S) - Z$. Substituting (91) into (28) leads to the condition in (27). \square

Corollary 1. *The covert capacity of the less noisy channel (i.e. $\mathbb{I}(U; Y) \geq \mathbb{I}(U; Z)$) with CSI is available non-causally at the transmitter is*

$$C_{\text{DC-T}} = \max[\mathbb{I}(U; Y) - \mathbb{I}(U; S)], \quad (29)$$

where the maximum is over distributions $Q_S P_{U|S} P_{X|U,S} W_{Y|S,X} W_{Z|Y}$, such that $\mathbb{E}[g(X)] \leq G$, $Q_Z = Q_0$.

Proof. Using Theorem 3 while choosing V independent of S (i.e. $P_{V|S} = P_V$) results in (29). Independence of V and S implies $\mathbb{I}(V; S) = 0$ and $\mathbb{I}(V; U, Y) = 0$ which, together with the less noisy condition, leads to (23) being satisfied. The converse utilizes Theorem 5 and the less noisy property of the channel. \square

B. Causal CSI

Theorem 6. *The covert capacity of the DMC $W_{Y,Z|S,X}$ with causal CSI at the transmitter is lower-bounded as*

$$C_{\text{C-T}} \geq \max[\mathbb{I}(U; Y) - \mathbb{I}(V; S) + \mathbb{I}(V; Y|U)], \quad (30)$$

where the maximum is over distributions $P_{S,U,X,Y,Z}(s, u, x, y, z) = Q_S(s)P_{V|S}(v|s)P_U(u)\mathbb{1}_{\{x(u,s)=x\}}W_{Y,Z|X,S}$, such that $\mathbb{E}[g(X)] \leq G$, $Q_Z = Q_0$, which are the marginal distributions defined in (1) and (2), and

$$\mathbb{I}(U; Y) + \mathbb{I}(V; Y|U) \geq \max\{\mathbb{I}(U; S; Z) - \mathbb{H}(S|V), \mathbb{I}(U; Z), \mathbb{I}(U; Z) + \mathbb{I}(S; Z) - \mathbb{H}(S|V)\}. \quad (31)$$

Theorem 6 is proved by a block Markov encoding, Shannon strategy for sending the message according to CSI, and Wyner-Ziv coding for secret key generation. We design a block Markov coding scheme in which the transmitter not only generates a key from S^n but also selects its codeword according to S^n . The details of the proof are available in Appendix F.

Theorem 7. *The covert capacity of the DMC $W_{Y,Z|S,X}$ with causal CSI at the transmitter is lower-bounded as*

$$C_{\text{C-T}} \geq \max[\mathbb{I}(U; Y) - \mathbb{H}(S|U, Y)], \quad (32)$$

where the maximum is over distributions $P_{S,U,X,Y,Z}(s, u, x, y, z) = Q_S(s)P_U(u)\mathbb{1}_{\{x(u,s)=x\}}W_{Y,Z|X,S}$, such that $\mathbb{E}[g(X)] \leq G$, $Q_Z = Q_0$, which are the marginal distributions defined in (1) and (2), and

$$\mathbb{I}(U; Y) - \mathbb{H}(S|U, Y) \geq \mathbb{I}(U; S; Z) - \mathbb{H}(S|U). \quad (33)$$

The proof is available in Appendix G.

Remark 3. Theorems 7 and 6 are two lower bounds for the same problem, whose relation is similar to corresponding results in the non-causal case. Please see Remark 2.

Theorem 8. The covert capacity of the DMC $W_{Y,Z|S,X}$ with causal CSI at the transmitter is upper-bounded as

$$C_{C-T} \leq \max \mathbb{I}(U; Y), \quad (34)$$

where the maximum is over distributions $Q_S P_U P_{X|U,S} W_{Y,Z|X,S}$, such that $\mathbb{E}[g(X)] \leq G$, $Q_Z = Q_0$, which are the marginal distributions defined in (1) and (2), and

$$\mathbb{H}(S|Z) \geq \mathbb{I}(U; S, Z) - \mathbb{I}(U; Y). \quad (35)$$

Proof. The proof for (34) is similar to that of [6, Theorem 1]. To prove (35) we have

$$\begin{aligned} nR &\stackrel{(a)}{\geq} n\mathbb{I}(\tilde{X}, \tilde{S}; \tilde{Z}) - n\mathbb{H}(\tilde{S}) \\ &\stackrel{(b)}{\geq} n\mathbb{I}(\tilde{U}, \tilde{S}; \tilde{Z}) - n\mathbb{H}(\tilde{S}) \end{aligned} \quad (36)$$

where (a) follows by the steps in (90) and (b) follows from the Markov chain $U - (X, S) - Z$. Substituting (91) into (36) leads to the condition in (35). \square

Corollary 2. The covert capacity for the less noisy channel (i.e. $\mathbb{I}(U; Y) \geq \mathbb{I}(U; Z)$) under causal CSI at the transmitter is

$$C_{DC-T} = \max \mathbb{I}(U; Y), \quad (37)$$

where the maximum is over distributions $Q_S P_U P_{X|U,S} W_{Y|S,X} W_{Z|Y}$, such that $\mathbb{E}[g(X)] \leq G$, $Q_Z = Q_0$.

Proof. Proof is similar to Corollary 1 and is omitted for brevity. \square

C. Strictly Causal CSI

The availability of strictly causal channel state information at the transmitter is useful because it provides a source of common randomness between the legitimate users, which can be used to generate a shared secret key between them to mislead the warden. Here, we only use the channel state information for key generation and not for data transmission.

Theorem 9. The covert capacity of the DMC $W_{Y,Z|S,X}$ with strictly causal CSI at the transmitter is lower-bounded

$$C_{SC} \geq \max[\mathbb{I}(X; Y) - \mathbb{I}(V; S) + \mathbb{I}(V; Y|X)], \quad (38)$$

where the maximum is over distributions $P_{S,V,X,Y,Z} = P_S P_{V|S} P_X W_{Y,Z|X,S}$ such that $\mathbb{E}[g(X)] \leq G$, $Q_Z = Q_0$, which are the marginal distributions defined in (1) and (2), and

$$\mathbb{I}(X; Y) + \mathbb{I}(V; Y|X) \geq \max\{\mathbb{I}(X, S; Z) - \mathbb{H}(S|V), \mathbb{I}(X; Z), \mathbb{I}(S; Z) + \mathbb{I}(X; Z) - \mathbb{H}(S|V)\}. \quad (39)$$

Theorem 9 is proved using a block Markov encoding and Wyner-Ziv coding to generate a secret key from channel state information. The proof is available in Appendix H.

Theorem 10. *The covert capacity of DMC $W_{Y,Z|S,X}$ with strictly causal CSI at the transmitter is lower-bounded as*

$$C_{\text{SC}} \geq \max[\mathbb{I}(X; Y) - \mathbb{H}(S|X, Y)], \quad (40)$$

$$(41)$$

where the maximum is over distributions of the form $P_{S,X,Y,Z} = P_S P_X W_{Y,Z|X,S}$ such that $\mathbb{E}[g(X)] \leq G$, $Q_Z = Q_0$, and

$$\mathbb{I}(X; Y) - \mathbb{H}(S|X, Y) \geq \mathbb{I}(X; Z|S) - \mathbb{H}(S|Z). \quad (42)$$

The proof is available in Appendix I and is similar to the proof of Theorem 9.

Remark 4. *Theorems 9 and 10 are two lower bounds for the same problem, whose relation is similar to corresponding results in the non-causal and causal cases. Please see Remark 2 for further details.*

Theorem 11. *The covert capacity of the DMC $W_{Y,Z|S,X}$ with strictly causal CSI at the transmitter is upper-bounded as*

$$C_{\text{SC-T}} \leq \max \mathbb{I}(X; Y), \quad (43)$$

where the maximum is over distributions $Q_S P_X W_{Y,Z|X,S}$, such that $\mathbb{E}[g(X)] \leq G$, $Q_Z = Q_0$, which are the marginal distributions defined in (1) and (2), and

$$\mathbb{H}(S|Z) \geq \mathbb{I}(X; S, Z) - \mathbb{I}(X; Y). \quad (44)$$

Proof. By using standard techniques,

$$\begin{aligned} nR &= \mathbb{H}(M) \\ &= \mathbb{I}(M; Y^n) + \mathbb{H}(M|Y^n) \\ &\leq \mathbb{I}(M; Y^n) + n\epsilon \\ &= \sum_{i=1}^n \mathbb{I}(M; Y_i | Y^{i-1}) + n\epsilon \\ &\leq \sum_{i=1}^n \mathbb{I}(M, Y^{i-1}; Y_i) + n\epsilon \\ &\stackrel{(a)}{\leq} \sum_{i=1}^n \mathbb{I}(M, S^{i-1}; Y_i) + n\epsilon \\ &\stackrel{(b)}{\leq} \sum_{i=1}^n \mathbb{I}(X_i; Y_i) + n\epsilon \end{aligned} \quad (45)$$

$$\stackrel{(c)}{\leq} n\mathbb{I}(\tilde{X}; \tilde{Y}) + n\epsilon \quad (46)$$

where (a) follows from the Markov chain $(M, Y^{i-1}) - (M, S^{i-1}) - Y_i$ and (b) follows since S_i is independent of $(M, S^{i-1}, X_i(M, S^{i-1}))$ and therefore

$$\mathbb{I}(M, S^{i-1}; Y_i | X_i) \leq \mathbb{I}(M, S^{i-1}; Y_i | X_i, S_i) = 0, \quad (47)$$

that is $(M, S^{i-1}) - X_i - Y_i$ forms a Markov chain. Also, (c) follows from the distribution of \tilde{X} and \tilde{Y} as follows:

$$P_{\tilde{X}}(x) \triangleq \frac{1}{n} \sum_{i=1}^n P_{X_i}(x) \quad (48)$$

$$P_{\tilde{X}, \tilde{Y}}(x, y) \triangleq P_{\tilde{X}}(x) \sum_s P_S(s) W_{Y|X, S}(y|x, s). \quad (49)$$

together with the concavity of mutual information with respect to input distribution.

From (45) and Lemma 1

$$nR \leq \sum_{i=1}^n \mathbb{I}(X_i; Y_i) + n\epsilon \quad (50)$$

$$\leq \sum_{i=1}^n C_{\text{SC-T}} \left(\frac{1}{n} \sum_{i=1}^n \mathbb{D}(P_{Z_i} \| Q_0), \frac{1}{n} \sum_{i=1}^n \mathbb{E}[g(X_i)] \right) + n\epsilon \quad (51)$$

$$\stackrel{(a)}{\leq} C_{\text{SC-T}}(\mathbb{D}(P_{Z^n} \| Q_0^{\otimes n}), \mathbb{E}[g(X_i)]) + n\epsilon \quad (52)$$

where (a) follows from the concavity of $C_{\text{SC}}(A, B)$. From Lemma 1, $C_{\text{SC}}(A, B)$ is non-decreasing in A and B and from the input cost constraint, there exists $\frac{1}{n} \sum_{i=1}^n \mathbb{E}[g(X_i)] \leq G + \delta_n$ such that $\delta_n \rightarrow 0$. From the covertness constraint there exists a $\delta'_n \rightarrow 0$ such that $\mathbb{D}(P_{Z^n} \| Q_0^{\otimes n}) \leq \delta'_n$. Following the reasoning in [22] and [3] one can show that

$$\mathbb{D}(P_{Z^n} \| Q_0^{\otimes n}) \geq \sum_{i=1}^n \mathbb{D}(P_{Z_i} \| Q_0). \quad (53)$$

Therefore from (52)

$$R \leq C_{\text{SC-T}}\left(\frac{\delta'_n}{n}, G + \delta_n\right) + \epsilon_n. \quad (54)$$

Note that when n grows, the right hand side of (54) converges to $C_{\text{SC-T}}(0, G)$ because of the continuity of $C_{\text{SC}}(A, B)$, from which the condition $P_Z = Q_0$ follows. To prove (44) note that

$$nR \stackrel{(a)}{\geq} n\mathbb{I}(\tilde{X}, \tilde{S}; \tilde{Z}) - n\mathbb{H}(\tilde{S}) \quad (55)$$

where (a) follows by the steps in (114). Substituting (91) into (55) leads to the condition in (44). \square

Remark 5. *The segment of the proof culminating in (45) implies that strictly causal CSI does not increase the capacity of a point-to-point DMC. This result is known (e.g., see [23, Page 13]) but to the best of our knowledge no formal proof for it exists in the literature.*

Corollary 3. *The covert capacity when the channel is degraded (i.e. $W_{Y,Z|S,X} = W_{Y|S,X}W_{Z|Y}$) and CSI is available strictly causally at the transmitter is*

$$C_{\text{DC-T}} = \max \mathbb{I}(X; Y), \quad (56)$$

where the maximum is over distributions of the form $Q_S P_X W_{Y|S,X} W_{Z|Y}$, such that $\mathbb{E}[g(X)] \leq G$, $Q_Z = Q_0$, which are the marginal distributions defined in (1) and (2).

Proof. The achievability proof follows from Theorem 9 by choosing V independent of S (i.e. $P_{V|S} = P_V$). In this case, we also have $\mathbb{I}(V; S) = 0$ and $\mathbb{I}(V; S|X, Y) = 0$. After some algebraic manipulation and using the degradedness of the channel one can show that the condition in (39) is automatically satisfied. To prove the converse we use Theorem 11 and the degradedness of the channel to show that, after some algebraic manipulation the condition in (44) is automatically satisfied. \square

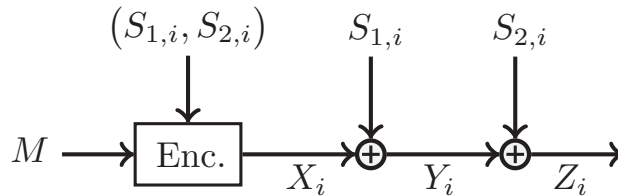

Fig. 5. Noiseless channel with additive CSI at the transmitter

VI. EXAMPLE

We provide an example in which the covert capacity is positive. Consider a channel in which X, Y, Z and $S = (S_1, S_2)$ are all binary, and let S_1, S_2 , and U be independent Bernoulli random variables with parameters $\alpha \in \llbracket 1, 0.5 \rrbracket$, $\beta \in \llbracket 1, 0.5 \rrbracket$, and $\lambda \in \llbracket 1, 0.5 \rrbracket$, respectively, and let $x_0 = 0$ (See Fig. 5). The channel state information is available causally at the Encoder and the law of the channel is as follows

$$Y = X \oplus S_1, \quad (57)$$

$$Z = Y \oplus S_2. \quad (58)$$

Theorem 12. *The covert capacity of the DMC channel depicted in Fig. 5 with causal CSI at the transmitter is*

$$C_{C-T} \stackrel{(a)}{=} \max_{\substack{P_U, \\ Q_Z=Q_0}} \mathbb{H}(U) \stackrel{(b)}{=} \mathbb{H}_b(\alpha) \quad (59)$$

where $\mathbb{H}_b(\cdot)$ is binary entropy.

Proof. The achievability proof for (a) follows from the achievability part of Corollary 2 and setting $X = U + S_1$. The converse part of (a) follows from the converse part of Corollary 2 and the fact that $\mathbb{I}(U; Y) \leq \mathbb{H}(U)$. To prove (b) in Theorem 12, we have

$$\begin{aligned} Q_0(z=0) &= P(s_1 + s_2 = 0) \\ &= P(s_1 = 0, s_2 = 0) + P(s_1 = 1, s_2 = 1) \\ &= (1 - \alpha)(1 - \beta) + \alpha\beta. \end{aligned} \quad (60)$$

The distribution induced at the output of the warden when transmitting a codeword is

$$\begin{aligned} Q_Z(z=0) &= P(U + S_2 = 0) \\ &= P(U = 0, s_2 = 0) + P(U = 1, s_2 = 1) \\ &= (1 - \lambda)(1 - \beta) + \lambda\beta. \end{aligned} \quad (61)$$

Therefore, the covertness constraint $Q_Z = Q_0$ requires

$$\lambda = \alpha. \quad (62)$$

□

VII. CONCLUSION

This paper studies keyless covert communication over state dependant channels, when the channel state information is available either at the transmitter alone, or at both the transmitter and receiver, but not to the adversary (warden). Our results show the feasibility of covertly communicating with a positive rate without an externally shared key between the transmitter and the receiver. This is in stark contrast with the known results showing that in the absence of channel state information, covert communication without a shared key is impossible at positive rates.

APPENDIX A

PROOF OF THEOREM 1

We use block-Markov coding in which $B - 1$ independent messages are transmitted over B channel blocks, each of length r , therefore the overall codeword length is $n = rB$ symbols. The warden's observation Z^n can be described in terms of observations in individual block-Markov blocks $Z^n = (Z_1^r, \dots, Z_B^r)$. The distribution of the warden's observation, induced by the block-Markov coding, is $P_{Z^n} \triangleq P_{Z_1^r, \dots, Z_B^r}$ and the target output distribution is $Q_Z^{\otimes n} = \prod_{j=1}^B Q_Z^{\otimes r}$.

$$\begin{aligned}
 \mathbb{D}(P_{Z^n} || Q_Z^{\otimes n}) &= \mathbb{D}(P_{Z_1^r \dots Z_B^r} || Q_Z^{\otimes rB}) \\
 &= \sum_{j=1}^B \mathbb{D}(P_{Z_j^r | Z_{j+1}^{B,r}} || Q_Z^{\otimes r} | P_{Z_{j+1}^{B,r}}) \\
 &= \sum_{j=1}^B [\mathbb{D}(P_{Z_j^r} || Q_Z^{\otimes r}) + \mathbb{D}(P_{Z_j^r | Z_{j+1}^{B,r}} || P_{Z_j^r} | P_{Z_{j+1}^{B,r}})] \\
 &= \sum_{j=1}^B [\mathbb{D}(P_{Z_j^r} || Q_Z^{\otimes r}) + \mathbb{I}(Z_j^r; Z_{j+1}^{B,r})], \tag{63}
 \end{aligned}$$

where $Z_{j+1}^{B,r} = \{Z_{j+1}^r, \dots, Z_B^r\}$. Hence, $\mathbb{D}(P_{Z^n} || Q_Z^{\otimes n}) \xrightarrow{n \rightarrow \infty} 0$, is equivalent to;

$$\mathbb{D}(P_{Z_j^r} || Q_Z^{\otimes r}) \xrightarrow{r \rightarrow \infty} 0, \quad \mathbb{I}(Z_j^r; Z_{j+1}^{B,r}) \xrightarrow{r \rightarrow \infty} 0, \quad \forall j \in \llbracket 1, B \rrbracket. \tag{64}$$

This requires constructing a code that approximates $Q_Z^{\otimes r}$ in each block, while eliminating the dependencies across blocks created by block-Markov coding. The random code generation is as follows:

Fix $P_{X|S}(x|s)$ and $\epsilon_1 > \epsilon_2 > 0$ such that, $Q_Z = Q_0$ and $g(X) \leq \frac{G}{1+\epsilon_2}$.

Codebook Generation for Keys: For each block $j \in \llbracket 1, B \rrbracket$, create a function $\Phi : S_j^r \rightarrow \llbracket 1, 2^{rR_k} \rrbracket$ through random binning by choosing the value of $\Phi(S_j^r)$ independently and uniformly at random for every $S_j^r \in S^r$. The key $k_j = \Phi(s_j^r)$ obtained in block $j \in \llbracket 1, B \rrbracket$ from the state sequence s_j^r is used to assist the encoder in the next block.

Rate Splitting: For each block $j \in \llbracket 1, B \rrbracket$, divide the message $M_j \in \llbracket 1, 2^{rR} \rrbracket$ and the key $K_{j-1} \in \llbracket 1, 2^{rR_k} \rrbracket$ into independent messages $M_{j,s} \in \llbracket 1, 2^{rR_s} \rrbracket$ and keys $K_{j-1,s} \in \llbracket 1, 2^{rR_{k,s}} \rrbracket$, respectively. Therefore, $R = \sum_s R_s$ and $R_k = \sum_s R_{k,s}$.

Codebook Generation for Messages: Let $P(a)$ be a probability assignment on the channel input letters which satisfy

$$\sum_a P(a)g(a) \leq G. \tag{65}$$

For each block $j \in \llbracket 1, B \rrbracket$ and for each $s \in \mathcal{S}$, randomly and independently generate $2^{r(R_s + R_{k,s})}$ codewords $x^{r_s}(k_{j-1,s}, m_{j,s}, s)$, $k_{j-1,s} \in \llbracket 1, 2^{rR_{k,s}} \rrbracket$, $m_{j,s} \in \llbracket 1, 2^{rR_s} \rrbracket$ according to

$$\tilde{P}(x^r | s) \triangleq \frac{1}{\mu} \mathbb{1}_{\{\sum_{i=1}^r g(x_i) \leq rG - \delta\}} \times \prod_{i=1}^r P(x_i | s), \quad (66)$$

where

$$\mu = \sum_{x^r} \mathbb{1}_{\{\sum_{i=1}^r g(x_i) \leq rG - \delta\}} \times \prod_{i=1}^r P(x_i | s), \quad (67)$$

and δ is an arbitrary positive number. Note that, $\tilde{P}(x^r | s)$ is not an i.i.d. distribution but we can bound it as

$$\tilde{P}(x^r | s) \leq \frac{1}{\mu} \times \prod_{i=1}^r P(x_i | s), \quad (68)$$

because $\mathbb{1}_{\{\sum_{i=1}^r g(x_i) \leq rG - \delta\}} \leq 1$. Assuming that S^r is a typical sequence according to Q_S (i.e. $s^r \in \mathcal{T}_\epsilon^{(r)}(Q_S)$) we have $r_s \geq r(1 - \epsilon)Q_S(s)$ where $r = \sum_s r_s$. The indices $(k_{j-1,s}, m_{j,s})$ can be viewed as a one-layer binning.

Encoding: For the first block, the transmitter generates a key from CSI and the encoder chooses (k_0, m_1) uniformly at random and finds codeword $x^r(k_0, m_1, s)$ according to these indices and the CSI.

For block $j \in \llbracket 2, B \rrbracket$, to send message $m_j = (m_{j,s} : s \in \mathcal{S})$ according to the generated key $k_{j-1} = (k_{j-1,s} : s \in \mathcal{S})$ from the previous block, the encoder forms the codeword tuple $(x^{r_s}(k_{j-1,s}, m_{j,s}, s) : s \in \mathcal{S})$. The encoder stores each of these codewords in a first-in first-out (FIFO) buffer of length r . At time $i \in \llbracket 1, r \rrbracket$, the encoder transmits the first untransmitted symbol from the FIFO buffer corresponding to the channel state s_i .

Define

$$\begin{aligned} \Upsilon_{K_{j-1}, M_j, X^r, S_j^r, Z_j^r, K_j}^{(C_n)}(k_{j-1}, m_j, \tilde{x}^r, s_j^r, z_j^r, k_j) &\triangleq Q_S^{\otimes r}(s_j^r) \times 2^{-r(R_k + R)} \times \mathbb{1}_{\{x^r(k_{j-1}, m_j, s_j^r) = \tilde{x}^r\}} \\ &\times W_{Z|X, S}^{\otimes r}(z_j^r | \tilde{x}^r, s_j^r) \times \mathbb{1}_{\{\Phi(s_j^r) = k_j\}}, \end{aligned} \quad (69)$$

where $x^r(k_{j-1}, m_j, s_j^r) = (x^{r_s}(k_{j-1,s}, m_{j,s}, s) : s \in \mathcal{S})$. For a fixed codebook \mathcal{C}_n , the induced joint distribution over the codebook (i.e. $P^{(C_n)}$) satisfies

$$\|P_{K_{j-1}, M_j, X^r, S_j^r, Z_j^r, K_j}^{(C_n)} - \Upsilon_{K_{j-1}, M_j, X^r, S_j^r, Z_j^r, K_j}^{(C_n)}\|_1 \leq \epsilon. \quad (70)$$

This intermediate distribution $\Upsilon^{(C_n)}$ approximates the true distribution $P^{(C_n)}$ and will be used in the sequel for bounding purposes. Expression (70) holds because the main difference in $\Upsilon^{(C_n)}$ is assuming the key K_{j-1} is uniformly distributed, which is made (arbitrarily) nearly uniform in $P^{(C_n)}$ with appropriate control of rate.

Decoding and Error Probability Analysis: At the end of block $j \in \llbracket 1, B \rrbracket$, using its knowledge of the channel state s_j^r of the current block and the key k_{j-1} generated from the previous block, the receiver demultiplexes the received sequence to $(y_j^{r_s}, s \in \mathcal{S})$. Then, for each s , it finds a unique \hat{m}_s such that $(x_j^{r_s}(k_{j-1,s}, \hat{m}_{j,s}, s), y_j^{r_s}) \in \mathcal{T}_\epsilon^{(r_s)}$. According to the law of large numbers and the packing lemma, the probability of error goes to zero as $r \rightarrow \infty$ if [24],

$$R_s \leq (1 - \epsilon)Q_S(s)\mathbb{I}(X; Y | S = s), \quad \forall s. \quad (71)$$

Therefore, the total probability of error goes to zero when r grows if

$$R < \mathbb{I}(X; Y | S). \quad (72)$$

Input Cost Analysis: If \mathcal{E} is the event that (5) is not satisfied, one can show that the probability of \mathcal{E} tends to zero as r tends to infinity.

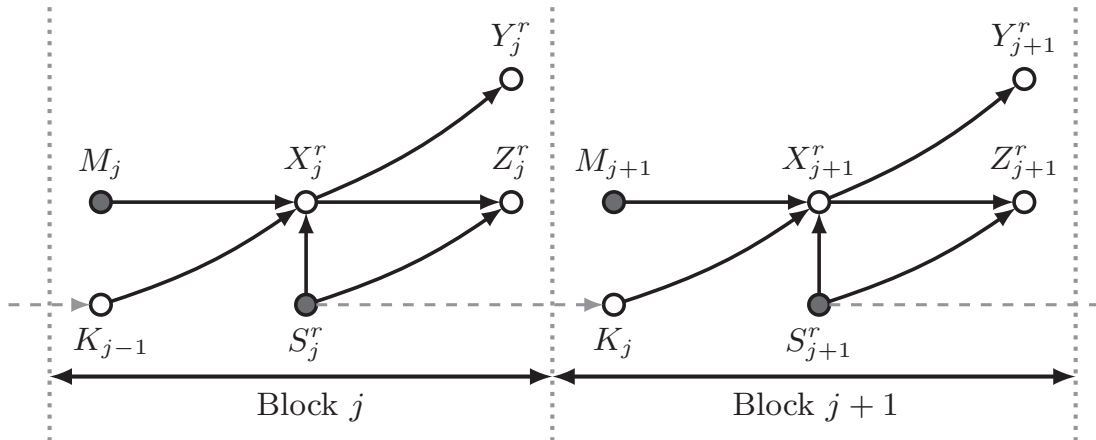

Fig. 6. Functional dependence graph for the block-Markov encoding scheme

Covert Analysis: We now show $\mathbb{E}_{\mathcal{C}_n}[\mathbb{D}(P_{Z^n}^{(\mathcal{C}_n)} \| Q_Z^{\otimes n})] \xrightarrow{n \rightarrow \infty} 0$. From the expansion in (63), for every $j \in \llbracket 2, B \rrbracket$,

$$\begin{aligned} \mathbb{I}(Z_j^r; Z_{j+1}^{B,r}) &\leq \mathbb{I}(Z_j^r; K_j, Z_{j+1}^{B,r}) \\ &\stackrel{(a)}{=} \mathbb{I}(Z_j^r; K_j), \end{aligned} \quad (73)$$

where (a) holds because $Z_j^r - K_j - Z_{j+1}^{B,r}$ forms a Markov chain, as seen in the functional dependence graph depicted in Fig. 6.

$$\begin{aligned} \mathbb{I}(Z_j^r; K_j) &= \mathbb{D}(P_{Z_j^r, K_j}^{(\mathcal{C}_n)} \| P_{Z_j^r}^{(\mathcal{C}_n)} P_{K_j}^{(\mathcal{C}_n)}) \\ &\stackrel{(b)}{\leq} \mathbb{D}(P_{Z_j^r, K_j}^{(\mathcal{C}_n)} \| Q_Z^{\otimes r} Q_{K_j}), \end{aligned} \quad (74)$$

where Q_{K_j} is the uniform distribution on $\llbracket 1, 2^{rR\kappa} \rrbracket$ and (b) follows from the positivity of relative entropy, and from

$$\mathbb{D}(P_{Z_j^r, K_j} \| P_{Z_j^r} P_{K_j}) = \mathbb{D}(P_{Z_j^r, K_j} \| Q_Z^{\otimes r} Q_{K_j}) - \mathbb{D}(P_{K_j} \| Q_{K_j}) - \mathbb{D}(P_{Z_j^r} \| Q_Z^{\otimes r}). \quad (75)$$

Therefore by combining (63), (74), and (75)

$$\mathbb{D}(P_{Z^n}^{(\mathcal{C}_n)} \| Q_Z^{\otimes n}) \leq 2 \sum_{j=1}^B \mathbb{D}(P_{Z_j^r, K_j}^{(\mathcal{C}_n)} \| Q_Z^{\otimes r} Q_{K_j}). \quad (76)$$

We now proceed to bound the right hand side of (76). First, consider the marginal

$$\Upsilon_{Z_j^r, K_j}^{(\mathcal{C}_n)}(z_j^r, k_j) = \sum_{s_j^r} \sum_{k_{j-1}} \sum_{m_j} \frac{1}{2^{r(R_k+R)}} Q_S^{\otimes r}(s_j^r) \times W_{Z|X,S}^{\otimes r}(z_j^r | x^r(k_{j-1}, m_j, s_j^r), s_j^r) \times \mathbb{1}_{\{\Phi(s_j^r)=k_j\}}. \quad (77)$$

Since an ℓ_1 bound on a distribution implies a bound on marginals, from (70)

$$\|\Upsilon_{Z_j^r, K_j}^{(\mathcal{C}_n)} - P_{Z_j^r, K_j}^{\mathcal{C}_n}\|_1 \leq \epsilon. \quad (78)$$

To bound the RHS of (76) by using triangle inequality we have

$$\|P_{Z_j^r, K_j}^{\mathcal{C}_n} - Q_Z^{\otimes r} Q_{K_j}\|_1 \leq \|P_{Z_j^r, K_j}^{\mathcal{C}_n} - \Upsilon_{Z_j^r, K_j}^{(\mathcal{C}_n)}\|_1 + \|\Upsilon_{Z_j^r, K_j}^{(\mathcal{C}_n)} - Q_Z^{\otimes r} Q_{K_j}\|_1. \quad (79)$$

The first term on the RHS of (79) vanishes as n grows; the second term is bounded as follows:

$$\begin{aligned}
& \mathbb{E}_{\mathcal{C}_n} [\mathbb{D}(\Upsilon_{Z_j^r, K_j}^{(C_n)} || Q_Z^{\otimes r} Q_{K_j})] = \mathbb{E}_{\mathcal{C}_n} \left[\sum_{z_j^r, k_j} \Upsilon^{(C_n)}(z_j^r, k_j) \log \left(\frac{\Upsilon^{(C_n)}(z_j^r, k_j)}{Q_Z^{\otimes r}(z_j^r) Q_{K_j}(k_j)} \right) \right] \\
& = \mathbb{E}_{\mathcal{C}_n} \left[\sum_{z_j^r, k_j} \sum_{k_{j-1}} \sum_{m_j} \frac{1}{2^{r(R_k+R)}} \sum_{s_j^r} Q_S^{\otimes r}(s_j^r) \times W_{Z|X,S}^{\otimes r}(z_j^r | X^r(k_{j-1}, m_j, s_j^r), s_j^r) \times \mathbb{1}_{\{\Phi(s_j^r)=k_j\}} \right. \\
& \quad \left. \times \log \left(\frac{\sum_{\tilde{s}_j^r} \sum_{\tilde{k}_{j-1}} \sum_{\tilde{m}_j} Q_S^{\otimes r}(\tilde{s}_j^r) \times W_{Z|X,S}^{\otimes r}(z_j^r | X^r(\tilde{k}_{j-1}, \tilde{m}_j, \tilde{s}_j^r), \tilde{s}_j^r) \times \mathbb{1}_{\{\Phi(\tilde{s}_j^r)=k_j\}}}{2^{r(R_k+R-R_K)} Q_Z^{\otimes r}(z_j^r)} \right) \right] \\
& \stackrel{(a)}{\leq} \sum_{k_j, z_j^r} \sum_{k_{j-1}} \sum_{m_j} \frac{1}{2^{r(R_k+R)}} \sum_{s_j^r} \sum_{x^r(k_{j-1}, m_j, s_j^r)} \Upsilon_{S^r, Z^r, X^r}^{(C_n)}(s_j^r, z_j^r, x^r(k_{j-1}, m_j, s_j^r)) \times \mathbb{E}_{\Phi(s_j^r)} [\mathbb{1}_{\{\Phi(s_j^r)=k_j\}}] \\
& \quad \times \log \mathbb{E}_{\setminus((k_{j-1}, m_j), \Phi(s_j^r))} \left[\frac{\sum_{\tilde{s}_j^r} \sum_{\tilde{k}_{j-1}} \sum_{\tilde{m}_j} Q_S^{\otimes r}(\tilde{s}_j^r) \times W_{Z|X,S}^{\otimes r}(z_j^r | X^r(\tilde{k}_{j-1}, \tilde{m}_j, \tilde{s}_j^r), \tilde{s}_j^r) \times \mathbb{1}_{\{\Phi(\tilde{s}_j^r)=k_j\}}}{2^{r(R_k+R-R_K)} Q_Z^{\otimes r}(z_j^r)} \right] \\
& \stackrel{(b)}{\leq} \sum_{k_j, z_j^r} \sum_{k_{j-1}} \sum_{m_j} \frac{1}{2^{r(R_k+R)}} \sum_{s_j^r} \sum_{x^r(k_{j-1}, m_j, s_j^r)} \Upsilon_{S^r, Z^r, X^r}^{(C_n)}(s_j^r, z_j^r, x^r(k_{j-1}, m_j, s_j^r)) \times \frac{1}{2^{rR_K}} \\
& \quad \times \log \left(\frac{Q_S^{\otimes r}(s_j^r) \times W_{Z|X,S}^{\otimes r}(z_j^r | x^r(k_{j-1}, m_j, s_j^r), s_j^r)}{2^{r(R_k+R-R_K)} Q_Z^{\otimes r}(z_j^r)} \right. \\
& \quad \left. + \mathbb{E}_{\setminus(k_{j-1}, m_j)} \left[\frac{\sum_{(\tilde{k}_{j-1}, \tilde{m}_j) \neq (k_{j-1}, m_j)} Q_S^{\otimes r}(s_j^r) \times W_{Z|X,S}^{\otimes r}(z_j^r | X^r(\tilde{k}_{j-1}, \tilde{m}_j, s_j^r), s_j^r) \times \mathbb{1}_{\{\Phi(s_j^r)=k_j\}}}{2^{r(R_k+R-R_K)} Q_Z^{\otimes r}(z_j^r)} \right] \right. \\
& \quad \left. + \mathbb{E}_{\setminus((k_{j-1}, m_j), \Phi(s_j^r))} \left[\frac{\sum_{\tilde{s}_j^r} \sum_{(\tilde{k}_{j-1}, \tilde{m}_j) \neq (k_{j-1}, m_j)} Q_S^{\otimes r}(\tilde{s}_j^r) \times W_{Z|X,S}^{\otimes r}(z_j^r | X^r(\tilde{k}_{j-1}, \tilde{m}_j, \tilde{s}_j^r), \tilde{s}_j^r) \times \mathbb{1}_{\{\Phi(\tilde{s}_j^r)=k_j\}}}{2^{r(R_k+R-R_K)} Q_Z^{\otimes r}(z_j^r)} \right] \right) \\
& \stackrel{(c)}{\leq} \sum_{k_j, z_j^r} \sum_{k_{j-1}} \sum_{m_j} \frac{1}{2^{r(R_k+R)}} \sum_{s_j^r} \sum_{x^r(k_{j-1}, m_j, s_j^r)} \Upsilon_{S^r, Z^r, X^r}^{(C_n)}(s_j^r, z_j^r, x^r(k_{j-1}, m_j, s_j^r)) \times \frac{1}{2^{rR_K}} \\
& \quad \times \log \left(\frac{Q_S^{\otimes r}(s_j^r) \times W_{Z|X,S}^{\otimes r}(z_j^r | x^r(k_{j-1}, m_j, s_j^r), s_j^r)}{2^{r(R_k+R-R_K)} Q_Z^{\otimes r}(z_j^r)} + \sum_{(k_{j-1}, m_j') \neq (k_{j-1}, m_j)} \frac{Q_{S,Z}^{\otimes r}(s_j^r, z_j^r)}{2^{r(R_k+R-R_K)} Q_Z^{\otimes r}(z_j^r)} + 1 \right) \\
& \triangleq \Psi_1 + \Psi_2, \tag{80}
\end{aligned}$$

where (a) follows from Jensen's inequality, (b) holds because $\mathbb{1}_{\{\Phi(s_j^r)=k_j\}} \leq 1$, (c) holds because $\mathbb{1}_{\{\Phi(s_j^r)=k_j\}} \leq 1$ and the last term in the RHS of (b) is smaller than 1. We defined Ψ_1 and Ψ_2 as

$$\begin{aligned}
\Psi_1 & = \sum_{k_j} \sum_{k_{j-1}} \sum_{m_j} \frac{1}{2^{r(R_k+R+R_K)}} \sum_{(s_j^r, z_j^r, x^r(k_{j-1}, m_j, s_j^r)) \in \mathcal{T}_e^{(n)}} \Upsilon_{S^r, Z^r, X^r}^{(C_n)}(s_j^r, z_j^r, x^r(k_{j-1}, m_j, s_j^r)) \\
& \quad \times \log \left(\frac{Q_S^{\otimes r}(s_j^r) \times W_{Z|X,S}^{\otimes r}(z_j^r | x^r(k_{j-1}, m_j, s_j^r), s_j^r)}{2^{r(R_k+R-R_K)} Q_Z^{\otimes r}(z_j^r)} + \frac{2^{rR_K} \times Q_{S,Z}^{\otimes r}(s_j^r, z_j^r)}{Q_Z^{\otimes r}(z_j^r)} + 1 \right) \\
& \leq \log \left(\frac{2^{rR_K} 2^{-r(1-\epsilon)(\mathbb{H}(S)+\mathbb{H}(Z|X,S))}}{2^{r(R_k+R)} 2^{-r(1+\epsilon)\mathbb{H}(Z)}} + \frac{2^{rR_K} 2^{-r(1-\epsilon)\mathbb{H}(S,Z)}}{2^{-r(1+\epsilon)\mathbb{H}(Z)}} + 1 \right) \\
\Psi_2 & = \sum_{k_j} \sum_{k_{j-1}} \sum_{m_j} \frac{1}{2^{r(R_k+R+R_K)}} \sum_{(s_j^r, z_j^r, x^r(k_{j-1}, m_j, s_j^r)) \notin \mathcal{T}_e^{(n)}} \Upsilon_{S^r, Z^r, X^r}^{(C_n)}(s_j^r, z_j^r, x^r(k_{j-1}, m_j, s_j^r))
\end{aligned} \tag{81}$$

$$\begin{aligned}
& \times \log \left(\frac{Q_S^{\otimes r}(s_j^r) \times W_{Z|X,S}^{\otimes r}(z_j^r | x^r(k_{j-1}, m_j, s_j^r), s_j^r)}{2^{r(R_k+R-R_K)} Q_Z^{\otimes r}(z_j^r)} + \frac{2^{rR_K} \times Q_{S,Z}^{\otimes r}(s_j^r, z_j^r)}{Q_Z^{\otimes r}(z_j^r)} + 1 \right) \\
& \leq 2|S||Z||X| e^{-r\epsilon\mu_{S,Z,X}} r \log\left(\frac{3}{\mu_Z} + 1\right), \tag{82}
\end{aligned}$$

Ψ_2 goes to zero when $r \rightarrow \infty$. By choosing $R_K = \mathbb{H}(S|Z) - \epsilon$, Ψ_1 goes to zero if,

$$R + R_k > \mathbb{I}(X; Z|S). \tag{83}$$

The region in Theorem 1 is obtained by remarking that the scheme requires

$$R_k \leq R_K = \mathbb{H}(S|Z) - \epsilon, \tag{84}$$

and applying Fourier-Motzkin to (72), (83), and (84).

We now develop an upper bound for the non-causal and causal side information. Assume a sequence of random codes satisfying $\mathbb{D}(P_{Z^n} || Q_Z^{\otimes n}) \leq \epsilon$ and the error probability is ϵ_n which tends to zero as n grows. For convenience, we reintroduce a lemma from [6, Lemma 5], which will be used for the proofs of the upper bounds:

Lemma 1. ([6, Lemma 5]) Consider the following functions on non-negative A and B :

$$\begin{aligned}
C_{\text{SC}}(A, B) &= \max_{\substack{P_X: \\ \mathbb{E}[g(X)] \leq B, \mathbb{D}(P_Z || Q_0) \leq A}} \mathbb{I}(X; Y, S), \\
C_C(A, B) &= \max_{\substack{P_{X|S}: \\ \mathbb{E}[g(X)] \leq B, \mathbb{D}(P_Z || Q_0) \leq A}} \mathbb{I}(X; Y, S) - \mathbb{I}(X; S),
\end{aligned}$$

the functions $C_{\text{SC}}(A, B)$ and $C_C(A, B)$, are non-decreasing in both A and B . They are also concave and continuous in (A, B) .

Using standard techniques we have

$$\begin{aligned}
nR &= \mathbb{H}(M) \\
&\stackrel{(a)}{\leq} \mathbb{H}(M|S^n) - \mathbb{H}(M|Y^n, S^n) + n\epsilon \\
&= \mathbb{I}(M; Y^n | S^n) + n\epsilon \\
&= \sum_{i=1}^n \mathbb{I}(M; Y_i | Y^{i-1}, S^n) + n\epsilon \\
&= \sum_{i=1}^n [\mathbb{H}(Y_i | Y^{i-1}, S^n) - \mathbb{H}(Y_i | M, Y^{i-1}, S^n)] + n\epsilon \\
&\stackrel{(b)}{\leq} \sum_{i=1}^n [\mathbb{H}(Y_i | S_i) - \mathbb{H}(Y_i | M, Y^{i-1}, S^n, X^n)] + n\epsilon \\
&\stackrel{(c)}{=} \sum_{i=1}^n [\mathbb{H}(Y_i | S_i) - \mathbb{H}(Y_i | X_i, S_i)] + n\epsilon \\
&= \sum_{i=1}^n \mathbb{I}(X_i; Y_i | S_i) + n\epsilon \tag{85}
\end{aligned}$$

$$\stackrel{(d)}{\leq} n\mathbb{I}(\tilde{X}; \tilde{Y} | \tilde{S}) + n\epsilon \tag{86}$$

where (a) follows from Fano's inequality and independence of M from S^n , (b) holds because conditioning does not increase entropy and X^n is a function of (M, S^n) , (c) holds because $(M, Y^{i-1}, S_i, X_i) - (X_i, S_i) - Y_i$ forms

a Markov chain, and the single-letterization in (d) is due to the concavity of mutual information, with the resulting random variables \tilde{X} , \tilde{S} , and \tilde{Y} having the following distributions

$$\begin{aligned}\tilde{P}_{X,S,Y}(x,s,y) &\triangleq \frac{1}{n} \sum_{i=1}^n P_{X_i,S_i,Y_i}(x,s,y), \\ \tilde{P}_{X,S,Y}(x,s,y) &= \tilde{P}_{X,S}(x,s)W_{Y|X,S}(y|x,s).\end{aligned}$$

Also, from (85) and Lemma 1 we have

$$\begin{aligned}nR &\leq \sum_{i=1}^n \mathbb{I}(X_i; Y_i | S_i) + n\epsilon \\ &\leq \sum_{i=1}^n C_C(\mathbb{D}(P_{Z_i} || Q_0), \mathbb{E}[g(X_i)]) + n\epsilon_n \\ &\leq C_C\left(\frac{1}{n} \sum_{i=1}^n \mathbb{D}(P_{Z_i} || Q_0), \frac{1}{n} \sum_{i=1}^n \mathbb{E}[g(X_i)]\right) + n\epsilon_n,\end{aligned}\tag{87}$$

where the last inequality follows from concavity of $C_C(A, B)$. From Lemma 1, we know that $C_C(\cdot, \cdot)$ is non-decreasing in its arguments, and from the input cost constraint, there exists $\frac{1}{n} \sum_{i=1}^n \mathbb{E}[g(X_i)] \leq G + \delta_n$ such that $\delta_n \rightarrow 0$. Also, from the covertness constraint, there exists $\delta'_n \rightarrow 0$ such that $\mathbb{D}(P_{Z^n} || Q_0^{\otimes n}) \leq \delta'_n$. Following the reasoning in [22] and [3]

$$\mathbb{D}(P_{Z^n} || Q_0^{\otimes n}) \geq \sum_{i=1}^n \mathbb{D}(P_{Z_i} || Q_0).\tag{88}$$

Therefore from (87)

$$R \leq C_C\left(\frac{\delta'_n}{n}, G + \delta_n\right) + \epsilon_n.\tag{89}$$

When n grows, the right hand side of (89) converges to $C_C(0, G)$ because of the continuity of $C_C(\cdot, \cdot)$, from which the condition $P_Z = Q_0$ follows.

We also have,

$$\begin{aligned}nR &= \mathbb{H}(M) \\ &= \mathbb{H}(M | S^n) \\ &\geq \mathbb{I}(M; Z^n | S^n) \\ &\stackrel{(a)}{=} \mathbb{I}(M, X^n; Z^n | S^n) \\ &\geq \mathbb{I}(X^n; Z^n | S^n) \\ &= \mathbb{I}(X^n, S^n; Z^n) - \mathbb{I}(S^n; Z^n) \\ &= \sum_{x^n} \sum_{s^n} \sum_{z^n} P(x^n, s^n, z^n) \log \frac{W_{Z|X,S}^{\otimes n}(z^n | x^n, s^n)}{P(z^n)} - \mathbb{H}(S^n) + \mathbb{H}(S^n | Z^n) \\ &\geq \sum_{x^n} \sum_{s^n} \sum_{z^n} P(x^n, s^n, z^n) \log \frac{W_{Z|X,S}^{\otimes n}(z^n | x^n, s^n)}{P(z^n)} + \mathbb{D}(P_{Z^n} || Q_Z^{\otimes n}) - \mathbb{H}(S^n) - \epsilon \\ &\geq \sum_{i=1}^n \sum_{x_i} \sum_{s_i} \sum_{z_i} P(x_i, s_i, z_i) \log \frac{W_{Z|X,S}^{\otimes n}(z_i | x_i, s_i)}{Q_Z(z_i)} - \sum_{i=1}^n \mathbb{H}(S_i) - \epsilon\end{aligned}$$

$$\begin{aligned}
&= \sum_{i=1}^n \mathbb{D}(P_{X_i, S_i, Z_i} \| P_{X_i, S_i} Q_Z) - \sum_{i=1}^n \mathbb{H}(S_i) - \epsilon \\
&\stackrel{(b)}{\geq} n\mathbb{D}(\tilde{P}_{X, S, Z} \| \tilde{P}_{X, S} Q_Z) - n\mathbb{H}(\tilde{S}) - \epsilon \\
&= n\mathbb{D}(\tilde{P}_{X, S, Z} \| \tilde{P}_{X, S} \tilde{P}_Z) + \mathbb{D}(\tilde{P}_Z \| Q_Z) - n\mathbb{H}(\tilde{S}) - \epsilon \\
&\geq n\mathbb{I}(\tilde{X}; \tilde{S}; \tilde{Z}) - n\mathbb{H}(\tilde{S})
\end{aligned} \tag{90}$$

where (a) holds because X^n is a function of (M, S^n) and (b) follows from Jensen's inequality, the convexity of $\mathbb{D}(\cdot \| \cdot)$, concavity of $\mathbb{H}(\cdot)$, and defining

$$\begin{aligned}
\tilde{P}_{X, S, Z}(x, s, z) &\triangleq \frac{1}{n} \sum_{i=1}^n P_{X_i, S_i, Z_i}(x, s, z), \\
\tilde{P}_{X, S}(x, s, z) &= \tilde{P}_{X, S}(x, s) W_{Y|X, S}(y|x, s).
\end{aligned}$$

Basic information identities yield:

$$\mathbb{I}(X, S; Z) = \mathbb{I}(X; S, Z) + \mathbb{I}(S; Z) - \mathbb{I}(X; S). \tag{91}$$

Substituting (91) into (90) leads to

$$nR \geq \mathbb{I}(\tilde{X}; \tilde{Z} | \tilde{S}) - \mathbb{H}(\tilde{S} | \tilde{Z}). \tag{92}$$

Combining (86) and (92) proves the converse in Theorem 1.

APPENDIX B PROOF OF THEOREM 2

We adopt a block-Markov encoding scheme in which $B-1$ independent messages are transmitted over B channel blocks each of length r , such that $n = rB$. The warden's observation is $Z^n = (Z_1^r, \dots, Z_B^r)$, the target output distribution is $Q_Z^{\otimes n}$, and Equation (63), describing the distance between the two distributions, continues to hold. The random code generation is as follows:

Fix $P(x)$ and $\epsilon_1 > \epsilon_2 > 0$ such that, $Q_Z = Q_0$ and $\mathbb{E}[g(X)] \leq \frac{G}{1+\epsilon_2}$.

Codebook Generation for Keys: For each block $j \in \llbracket 1, B \rrbracket$, create a function $\Phi : S_j^r \rightarrow \llbracket 1, 2^{rR_k} \rrbracket$ through random binning by choosing the value of $\Phi(S_j^r)$ independently and uniformly at random for every $S_j^r \in S^r$. The key $k_j = \Phi(s_j^r)$ obtained in block $j \in \llbracket 1, B \rrbracket$ from the state sequence s_j^r is used to assist the encoder in the next block.

Codebook Generation for Messages: For each block $j \in \llbracket 1, B \rrbracket$ and for each $k_{j-1} \in \llbracket 1, 2^{rR_k} \rrbracket$ and $m_j \in \llbracket 1, 2^{rR} \rrbracket$ randomly and independently generate codewords $x^r(k_{j-1}, m_j)$ according to

$$\tilde{P}(x^r) \triangleq \frac{1}{\mu} \mathbb{1}_{\{\sum_{i=1}^r g(x_i) \leq rG - \delta\}} \times \prod_{i=1}^r P(x_i), \tag{93}$$

where

$$\mu = \sum_{x^r} \mathbb{1}_{\{\sum_{i=1}^r g(x_i) \leq rG - \delta\}} \times \prod_{i=1}^r P(x_i), \tag{94}$$

and δ is an arbitrary positive number. Note that, $\tilde{P}(x^r)$ is not an i.i.d. distribution but we can bound it as

$$\tilde{P}(x^r) \leq \frac{1}{\mu} \times \prod_{i=1}^r P(x_i), \tag{95}$$

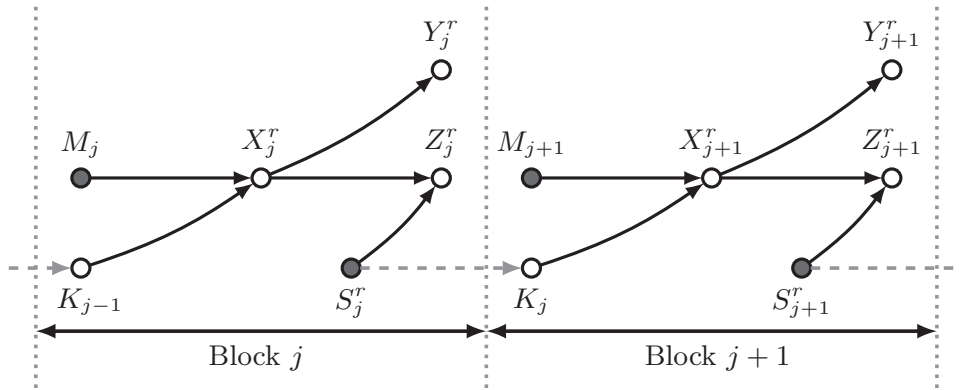

Fig. 7. Functional dependence graph for the block-Markov encoding scheme

because $\mathbb{1}_{\{\sum_{i=1}^r g(x_i) \leq rG - \delta\}} \leq 1$. These constitute the codebook \mathcal{C}_n .

Encoding: In the first block, the encoder chooses a codeword randomly and transmits it over the channel. At the end of the first block, the encoder knows the channel state information S_1^r of the first block and uses it to generate a key k_1 for the next block. In block $j \in \llbracket 2, B \rrbracket$, the codeword X^r is chosen based on a new message and the previously generated key k_{j-1} ; the encoder generates a key k_j from the CSI s_j^r at the end of the block.

Define

$$\begin{aligned} \Upsilon_{K_{j-1}, M_j, X^r, S_j^r, Z_j^r, K_j}^{(\mathcal{C}_n)}(k_{j-1}, m_j, \tilde{x}^r, s_j^r, z_j^r, k_j) &\triangleq Q_S^{\otimes r}(s_j^r) \times 2^{-r(R_k+R)} \times \mathbb{1}_{\{x^r(k_{j-1}, m_j) = \tilde{x}^r\}} \\ &\times W_{Z|X, S}^{\otimes r}(z_j^r | \tilde{x}^r, s_j^r) \times \mathbb{1}_{\{\Phi(s_j^r) = k_j\}}. \end{aligned} \quad (96)$$

For a fixed codebook \mathcal{C}_n , the induced joint distribution over the codebook (i.e. $P^{(\mathcal{C}_n)}$) satisfies

$$\|P_{K_{j-1}, M_j, X^r, S_j^r, Z_j^r, K_j}^{(\mathcal{C}_n)} - \Upsilon_{K_{j-1}, M_j, X^r, S_j^r, Z_j^r, K_j}^{(\mathcal{C}_n)}\|_1 \leq \epsilon. \quad (97)$$

This intermediate distribution $\Upsilon^{(\mathcal{C}_n)}$ approximates the true distribution $P^{(\mathcal{C}_n)}$ and will be used in the sequel for bounding purposes. Expression (97) holds because the main difference in $\Upsilon^{(\mathcal{C}_n)}$ is assuming the key K_{j-1} is uniformly distributed, which is made (arbitrarily) nearly uniform in $P^{(\mathcal{C}_n)}$ with appropriate control of rate.

Covert Analysis: We now show that this coding scheme guarantees that $\mathbb{E}_{\mathcal{C}_n}[\mathbb{D}(P_{Z^n}^{(\mathcal{C}_n)} || Q_Z^{\otimes n})] \xrightarrow{n \rightarrow \infty} 0$.

Similar to (76), by using the functional dependence graph depicted in Fig. 7,

$$\mathbb{D}(P_{Z^n}^{(\mathcal{C}_n)} || Q_Z^{\otimes n}) \leq 2 \sum_{j=1}^B \mathbb{D}(P_{Z_j^r, K_j}^{(\mathcal{C}_n)} || Q_Z^{\otimes r} Q_{K_j}). \quad (98)$$

We now proceed to bound the right hand side of (98). First, consider the marginal

$$\Upsilon_{Z_j^r, K_j}^{(\mathcal{C}_n)}(z_j^r, k_j) = \sum_{s_j^r} \sum_{k_{j-1}} \sum_{m_j} \frac{1}{2^{r(R_k+R)}} Q_S^{\otimes r}(s_j^r) \times W_{Z|X, S}^{\otimes r}(z_j^r | x^r(k_{j-1}, m_j), s_j^r) \times \mathbb{1}_{\{\Phi(s_j^r) = k_j\}}. \quad (99)$$

Therefore, from (97)

$$\|\Upsilon_{Z_j^r, K_j}^{(\mathcal{C}_n)} - P_{Z_j^r, K_j}^{\mathcal{C}_n}\|_1 \leq \epsilon. \quad (100)$$

To bound the RHS of (98) by using triangle inequality

$$\|P_{Z_j^r, K_j}^{\mathcal{C}_n} - Q_Z^{\otimes r} Q_{K_j}\|_1 \leq \|P_{Z_j^r, K_j}^{\mathcal{C}_n} - \Upsilon_{Z_j^r, K_j}^{(\mathcal{C}_n)}\|_1 + \|\Upsilon_{Z_j^r, K_j}^{(\mathcal{C}_n)} - Q_Z^{\otimes r} Q_{K_j}\|_1. \quad (101)$$

The first term on the RHS of (101) goes to zero as n grows, we now analyze the second term on RHS of (101)

$$\begin{aligned}
\mathbb{E}_{\mathcal{C}_n}[\mathbb{D}(\Upsilon_{Z_j^r, K_j}^{(\mathcal{C}_n)} || Q_Z^{\otimes r} Q_{K_j})] &= \mathbb{E}_{\mathcal{C}_n} \left[\sum_{z_j^r, k_j} \Upsilon^{(\mathcal{C}_n)}(z_j^r, k_j) \log \left(\frac{\Upsilon^{(\mathcal{C}_n)}(z_j^r, k_j)}{Q_Z^{\otimes r}(z_j^r) Q_{K_j}(k_j)} \right) \right] \\
&= \mathbb{E}_{\mathcal{C}_n} \left[\sum_{k_j, z_j^r} \sum_{k_{j-1}} \sum_{m_j} \frac{1}{2^{r(R_k+R)}} \sum_{s_j^r} Q_S^{\otimes r}(s_j^r) \times W_{Z|X,S}^{\otimes r}(z_j^r | X^r(k_{j-1}, m_j), s_j^r) \times \mathbb{1}_{\{\Phi(s_j^r)=k_j\}} \right. \\
&\quad \left. \times \log \left(\frac{\sum_{\tilde{s}_j^r} \sum_{\tilde{k}_{j-1}} \sum_{\tilde{m}_j} Q_S^{\otimes r}(\tilde{s}_j^r) \times W_{Z|X,S}^{\otimes r}(z_j^r | X^r(\tilde{k}_{j-1}, \tilde{m}_j), \tilde{s}_j^r) \times \mathbb{1}_{\{\Phi(\tilde{s}_j^r)=k_j\}}}{2^{r(R_k+R-R_K)} Q_Z^{\otimes r}(z_j^r)} \right) \right] \\
&\stackrel{(a)}{\leq} \sum_{k_j, z_j^r} \sum_{k_{j-1}} \sum_{m_j} \frac{1}{2^{r(R_k+R)}} \sum_{s_j^r} \sum_{x^r(k_{j-1}, m_j)} \Upsilon_{S^r, Z^r, X^r}^{(\mathcal{C}_n)}(s_j^r, z_j^r, x^r(k_{j-1}, m_j)) \times \mathbb{E}_{\Phi(s_j^r)} [\mathbb{1}_{\{\Phi(s_j^r)=k_j\}}] \\
&\quad \times \log \mathbb{E}_{\lambda((k_{j-1}, m_j), \Phi(s_j^r))} \left[\frac{\sum_{\tilde{s}_j^r} \sum_{\tilde{k}_{j-1}} \sum_{\tilde{m}_j} Q_S^{\otimes r}(\tilde{s}_j^r) \times W_{Z|X,S}^{\otimes r}(z_j^r | X^r(\tilde{k}_{j-1}, \tilde{m}_j), \tilde{s}_j^r) \times \mathbb{1}_{\{\Phi(\tilde{s}_j^r)=k_j\}}}{2^{r(R_k+R-R_K)} Q_Z^{\otimes r}(z_j^r)} \right] \\
&\stackrel{(b)}{\leq} \sum_{k_j, z_j^r} \sum_{k_{j-1}} \sum_{m_j} \frac{1}{2^{r(R_k+R)}} \sum_{s_j^r} \sum_{x^r(k_{j-1}, m_j)} \Upsilon_{S^r, Z^r, X^r}^{(\mathcal{C}_n)}(s_j^r, z_j^r, x^r(k_{j-1}, m_j)) \times \frac{1}{2^{rR_K}} \\
&\quad \times \log \left(\frac{Q_S^{\otimes r}(s_j^r) \times W_{Z|X,S}^{\otimes r}(z_j^r | x^r(k_{j-1}, m_j), s_j^r)}{2^{r(R_k+R-R_K)} Q_Z^{\otimes r}(z_j^r)} \right) \\
&\quad + \mathbb{E}_{\lambda(k_{j-1}, m_j)} \left[\frac{\sum_{(\tilde{k}_{j-1}, \tilde{m}_j) \neq (k_{j-1}, m_j)} Q_S^{\otimes r}(s_j^r) \times W_{Z|X,S}^{\otimes r}(z_j^r | X^r(\tilde{k}_{j-1}, \tilde{m}_j), s_j^r) \times \mathbb{1}_{\{\Phi(s_j^r)=k_j\}}}{2^{r(R_k+R-R_K)} Q_Z^{\otimes r}(z_j^r)} \right] \\
&\quad + \mathbb{E}_{\lambda(\Phi(s_j^r))} \left[\frac{\sum_{\tilde{s}_j^r \neq s_j^r} Q_S^{\otimes r}(\tilde{s}_j^r) \times W_{Z|X,S}^{\otimes r}(z_j^r | x^r(k_{j-1}, m_j), \tilde{s}_j^r) \times \mathbb{1}_{\{\Phi(\tilde{s}_j^r)=k_j\}}}{2^{r(R_k+R-R_K)} Q_Z^{\otimes r}(z_j^r)} \right] \\
&\quad + \mathbb{E}_{\lambda((k_{j-1}, m_j), \Phi(s_j^r))} \left[\frac{\sum_{\tilde{s}_j^r \neq s_j^r} \sum_{(\tilde{k}_{j-1}, \tilde{m}_j) \neq (k_{j-1}, m_j)} Q_S^{\otimes r}(\tilde{s}_j^r) \times W_{Z|X,S}^{\otimes r}(z_j^r | X^r(\tilde{k}_{j-1}, \tilde{m}_j), \tilde{s}_j^r) \times \mathbb{1}_{\{\Phi(\tilde{s}_j^r)=k_j\}}}{2^{r(R_k+R-R_K)} Q_Z^{\otimes r}(z_j^r)} \right] \\
&\stackrel{(c)}{\leq} \sum_{k_j, z_j^r} \sum_{k_{j-1}} \sum_{m_j} \frac{1}{2^{r(R_k+R)}} \sum_{s_j^r} \sum_{x^r(k_{j-1}, m_j)} \Upsilon_{S^r, Z^r, X^r}^{(\mathcal{C}_n)}(s_j^r, z_j^r, x^r(k_{j-1}, m_j)) \times \frac{1}{2^{rR_K}} \\
&\quad \times \log \left(\frac{Q_S^{\otimes r}(s_j^r) \times W_{Z|X,S}^{\otimes r}(z_j^r | x^r(k_{j-1}, m_j), s_j^r)}{2^{r(R_k+R-R_K)} Q_Z^{\otimes r}(z_j^r)} + \sum_{(\tilde{k}_{j-1}, \tilde{m}_j) \neq (k_{j-1}, m_j)} \frac{Q_{S,Z}^{\otimes r}(s_j^r, z_j^r)}{2^{r(R_k+R-R_K)} Q_Z^{\otimes r}(z_j^r)} \right) \\
&\quad + \sum_{\tilde{s}_j^r \neq s_j^r} \frac{Q_S^{\otimes r}(\tilde{s}_j^r) \times W_{Z|X,S}^{\otimes r}(z_j^r | x^r(k_{j-1}, m_j), \tilde{s}_j^r)}{2^{r(R_k+R)} Q_Z^{\otimes r}(z_j^r)} + 1 \Big) \\
&\triangleq \Psi_1 + \Psi_2, \tag{102}
\end{aligned}$$

where (a) follows from Jensen's inequality, (b) and (c) are because $\mathbb{1}_{\{\Phi(s_j^r)=k_j\}} \leq 1$, and the last term in the RHS of (b) is smaller than 1. We defined Ψ_1 and Ψ_2 as

$$\Psi_1 = \sum_{k_j} \sum_{k_{j-1}} \sum_{m_j} \frac{1}{2^{r(R_k+R+R_K)}} \sum_{(s_j^r, z_j^r, x^r(k_{j-1}, m_j)) \in \mathcal{T}_\epsilon^{(n)}} \Upsilon_{S^r, Z^r, X^r}^{(\mathcal{C}_n)}(s_j^r, z_j^r, x^r(k_{j-1}, m_j))$$

$$\begin{aligned}
& \times \log \left(\frac{Q_S^{\otimes r}(s_j^r) \times W_{Z|X,S}^{\otimes r}(z_j^r|x^r(k_{j-1}, m_j), s_j^r)}{2^{r(R_k+R-R_K)} Q_Z^{\otimes r}(z_j^r)} + \frac{2^{rR_K} \times Q_{S,Z}^{\otimes r}(s_j^r, z_j^r)}{Q_Z^{\otimes r}(z_j^r)} \right. \\
& \left. + \frac{Q_{Z|X}^{\otimes r}(z_j^r|x^r(k_{j-1}, m_j))}{2^{r(R_k+R)} Q_Z^{\otimes r}(z_j^r)} + 1 \right) \\
& \leq \log \left(\frac{2^{rR_K} 2^{-r(1-\epsilon)(\mathbb{H}(S)+\mathbb{H}(Z|X,S))}}{2^{r(R_k+R)} 2^{-r(1+\epsilon)\mathbb{H}(Z)}} + \frac{2^{rR_K} 2^{-r(1-\epsilon)\mathbb{H}(S,Z)}}{2^{-r(1+\epsilon)\mathbb{H}(Z)}} + \frac{2^{-r(1-\epsilon)\mathbb{H}(Z|X)}}{2^{r(R_k+R)} 2^{-r(1+\epsilon)\mathbb{H}(Z)}} + 1 \right) \quad (103)
\end{aligned}$$

$$\begin{aligned}
\Psi_2 &= \sum_{k_j} \sum_{k_{j-1}} \sum_{m_j} \frac{1}{2^{r(R_k+R+R_K)}} \sum_{(s_j^r, z_j^r, x^r(k_{j-1}, m_j)) \notin \mathcal{T}_\epsilon^{(n)}} \Upsilon_{S^r, Z^r, X^r}^{(C_n)}(s_j^r, z_j^r, x^r(k_{j-1}, m_j)) \\
& \times \log \left(\frac{Q_S^{\otimes r}(s_j^r) \times W_{Z|X,S}^{\otimes r}(z_j^r|x^r(k_{j-1}, m_j), s_j^r)}{2^{r(R_k+R-R_K)} Q_Z^{\otimes r}(z_j^r)} + \frac{2^{rR_K} \times Q_{S,Z}^{\otimes r}(s_j^r, z_j^r)}{Q_Z^{\otimes r}(z_j^r)} \right. \\
& \left. + \frac{Q_{Z|X}^{\otimes r}(z_j^r|x^r(k_{j-1}, m_j))}{2^{r(R_k+R)} Q_Z^{\otimes r}(z_j^r)} + 1 \right) \\
& \leq 2|S||Z||X| e^{-r\epsilon\mu_{S,Z,X}} r \log\left(\frac{3}{\mu_Z} + 1\right), \quad (104)
\end{aligned}$$

Ψ_2 goes to zero when $r \rightarrow \infty$. By choosing $R_K = \mathbb{H}(S|Z) - \epsilon$, Ψ_1 goes to zero if,

$$R + R_k > \mathbb{I}(X; Z|S), \quad (105)$$

$$R + R_k > \mathbb{I}(X; Z). \quad (106)$$

Here (106) is redundant because of (105) and the fact that X and S are independent.

Decoding and Error Probability Analysis: At the end of block $j \in \llbracket 1, B \rrbracket$, using the channel state s_j^r of the current block and the key k_{j-1} generated from the previous block, the receiver declares that $\hat{m}_j = m_j$ if there exists a unique index \hat{m}_j such that $(x^r(k_{j-1}, \hat{m}_j), y_j^r, s_j^r) \in \mathcal{T}_\epsilon^{(n)}(X, Y, S)$. The probability of error goes to zero as $r \rightarrow \infty$ if [24],

$$R \leq \mathbb{I}(X; S, Y). \quad (107)$$

Input Cost Analysis: If \mathcal{E} is the event that (5) is not satisfied one can show that the probability of \mathcal{E} tends to zero as r tends to infinity.

The region in Theorem 2 is derived by remarking that the scheme requires

$$R_k \leq R_K = \mathbb{H}(S|Z) - \epsilon, \quad (108)$$

and applying Fourier-Motzkin to (105), (107), and (108).

To establish the upper bound, consider any sequence of length- n codes for a state-dependent channel with channel state available strictly causally at both the transmitter and the receiver such that $P_e^{(n)} \leq \epsilon_n$, $\mathbb{D}(P_{Z^n} || Q_0^{\otimes n}) \leq \delta_n$, and $\lim_{n \rightarrow \infty} g(X^n) \leq G$, and $\lim_{n \rightarrow \infty} \epsilon_n = \lim_{n \rightarrow \infty} \delta_n = 0$. We upper bound nR using standard techniques.

$$\begin{aligned}
nR &= \mathbb{H}(M) \\
&= \mathbb{H}(M|S^n) - \mathbb{H}(M|Y^n, S^n) + n\epsilon_n \\
&\leq \mathbb{I}(M; Y^n|S^n) + n\epsilon_n \\
&= \sum_{i=1}^n \mathbb{I}(M; Y_i|Y^{i-1}, S^n) + n\epsilon_n
\end{aligned}$$

$$\begin{aligned}
&\leq \sum_{i=1}^n \mathbb{I}(M, Y^{i-1}, X_i; Y_i | S^n) + n\epsilon_n \\
&= \sum_{i=1}^n [\mathbb{H}(Y_i | S^n) - \mathbb{H}(Y_i | S^n, Y^{i-1}, X_i, M)] + n\epsilon_n \\
&\stackrel{(a)}{\leq} \sum_{i=1}^n \mathbb{I}(X_i; Y_i | S_i) + n\epsilon_n \tag{109}
\end{aligned}$$

$$\stackrel{(b)}{\leq} n\mathbb{I}(\tilde{X}; \tilde{Y} | \tilde{S}) + n\epsilon_n, \tag{110}$$

where (a) holds because conditioning does not increase entropy and $(M, Y^{i-1}, S_{\sim i}^n, X_{\sim i}^n) - (X_i, S_i) - Y_i$ forms a Markov chain, (b) follows from concavity of mutual information, with respect to the input distribution, with the random variables \tilde{X} , \tilde{S} , and \tilde{Y} having the following distributions

$$\begin{aligned}
\tilde{P}_{X,S,Y}(x, s, y) &\triangleq \frac{1}{n} \sum_{i=1}^n P_{X_i, S_i, Y_i}(x, s, y), \\
\tilde{P}_{X,S,Y}(x, s, y) &= \tilde{P}_X(x) \tilde{P}_S(s) W_{Y|X,S}(y|x, s).
\end{aligned}$$

Now, from the definition and property of $C_{\text{SC}}(A, B)$ and (109)

$$\begin{aligned}
nR &\leq \sum_{i=1}^n \mathbb{I}(X_i; Y_i | S_i) + n\epsilon_n \\
&= \sum_{i=1}^n \mathbb{I}(X_i; Y_i, S_i) + n\epsilon_n \\
&\leq \sum_{i=1}^n C_{\text{SC-TR}}(\mathbb{D}(P_{Z_i} || Q_0), \mathbb{E}[g(X_i)]) + n\epsilon_n \\
&\leq nC_{\text{SC-TR}}\left(\frac{1}{n} \sum_{i=1}^n \mathbb{D}(P_{Z_i} || Q_0), \frac{1}{n} \sum_{i=1}^n \mathbb{E}[g(X_i)]\right) + n\epsilon_n \tag{111}
\end{aligned}$$

where the last inequality follows from concavity of $C_{\text{SC}}(A, B)$. From Lemma 1 we know that $C_{\text{SC}}(\cdot, \cdot)$ is non-decreasing in its arguments, and from the input cost constraint, there exists $\frac{1}{n} \sum_{i=1}^n \mathbb{E}[g(X_i)] \leq G + \delta_n$ such that $\delta_n \rightarrow 0$. Also, from the covertness constraint, there exists a $\delta'_n \rightarrow 0$ such that $\mathbb{D}(P_{Z^n} || Q_0^{\otimes n}) \leq \delta'_n$. Following the reasoning in [22] and [3]

$$\mathbb{D}(P_{Z^n} || Q_0^{\otimes n}) \geq \sum_{i=1}^n \mathbb{D}(P_{Z_i} || Q_0). \tag{112}$$

Therefore from (111)

$$R \leq C_{\text{SC-TR}}\left(\frac{\delta'_n}{n}, G + \delta_n\right) + \epsilon_n. \tag{113}$$

Note that when n grows the right hand side of (113) goes to $C_{\text{SC-TR}}(0, G)$ because of the continuity of $C_{\text{SC}}(\cdot, \cdot)$, from which the condition $P_Z = Q_0$ follows.

We also have,

$$\begin{aligned}
nR &= \mathbb{H}(M) \\
&= \mathbb{H}(M | S^n) \\
&\geq \mathbb{I}(M; Z^n | S^n)
\end{aligned}$$

$$\begin{aligned}
&\stackrel{(a)}{=} \mathbb{I}(M, X^n; Z^n | S^n) \\
&\geq \mathbb{I}(X^n; Z^n | S^n) \\
&= \mathbb{I}(X^n, S^n; Z^n) - \mathbb{I}(S^n; Z^n) \\
&= \sum_{x^n} \sum_{s^n} \sum_{z^n} P(x^n, s^n, z^n) \log \frac{P(x^n, s^n, z^n)}{P(x^n, s^n)P(z^n)} - \mathbb{H}(S^n) + \mathbb{H}(S^n | Z^n) \\
&= \sum_{x^n} \sum_{s^n} \sum_{z^n} P(x^n, s^n, z^n) \log \frac{W_{Z|X,S}^{\otimes n}(z^n | x^n, s^n)}{P(z^n)} - \mathbb{H}(S^n) + \mathbb{H}(S^n | Z^n) \\
&= \sum_{x^n} \sum_{s^n} \sum_{z^n} P(x^n, s^n, z^n) \log \frac{W_{Z|X,S}^{\otimes n}(z^n | x^n, s^n)}{P(z^n)} + \mathbb{D}(P_{Z^n} \| Q_Z^{\otimes n}) - \mathbb{H}(S^n) - \epsilon \\
&\geq \sum_{i=1}^n \sum_{x_i} \sum_{s_i} \sum_{z_i} P(x_i, s_i, z_i) \log \frac{W_{Z|X,S}^{\otimes n}(z_i | x_i, s_i)}{Q_Z(z_i)} - \sum_{i=1}^n \mathbb{H}(S_i) - \epsilon \\
&= \sum_{i=1}^n \mathbb{D}(P_{X_i, S_i, Z_i} \| P_{X_i, S_i} Q_{Z_i}) - \sum_{i=1}^n \mathbb{H}(S_i) - \epsilon \\
&\stackrel{(b)}{\geq} n\mathbb{D}(\tilde{P}_{X,S,Z} \| \tilde{P}_{X,S} Q_Z) - n\mathbb{H}(\tilde{S}) - \epsilon \\
&= n\mathbb{D}(\tilde{P}_{X,S,Z} \| \tilde{P}_{X,S} \tilde{P}_Z) + \mathbb{D}(\tilde{P}_Z \| Q_Z) - n\mathbb{H}(\tilde{S}) - \epsilon \\
&\geq n\mathbb{I}(\tilde{X}, \tilde{S}; \tilde{Z}) - n\mathbb{H}(\tilde{S})
\end{aligned} \tag{114}$$

where (a) follows because X^n is a function of M and (b) follows from Jensen's inequality, the convexity of $\mathbb{D}(\cdot \| \cdot)$, concavity of $\mathbb{H}(\cdot)$, and defining

$$\begin{aligned}
\tilde{P}_{X,S,Z}(x, s, z) &\triangleq \frac{1}{n} \sum_{i=1}^n P_{X_i, S_i, Z_i}(x, s, z), \\
\tilde{P}_{X,S,Z}(x, s, z) &= \tilde{P}_S(s) \tilde{P}_X(x) W_{Y|X,S}(y | x, s).
\end{aligned}$$

Substituting (91) into (114) leads to

$$R \geq \mathbb{I}(\tilde{X}; \tilde{Z} | \tilde{S}) - \mathbb{H}(\tilde{S} | \tilde{Z}). \tag{115}$$

Combining (110) and (115) proves the converse part of Theorem 2.

APPENDIX C

PROOF OF THEOREM 3

We adopt a block-Markov encoding scheme in which $B-1$ independent messages are transmitted over B channel blocks each of length r , such that $n = rB$. The warden's observation is $Z^n = (Z_1^r, \dots, Z_B^r)$, the target output distribution is $Q_Z^{\otimes n}$, and Equation (63), describing the distance between the two distributions, continues to hold. The random code generation is as follows:

Fix $P_{V|S}(v|s)$, $P_{U|S}(u|s)$, $x(u, s)$, $P_{S,U,V,X,Y,Z}(s, u, x, y, z) = Q_S(s)P_{U|S}(u|s)P_{V|S}(v|s)\mathbb{1}_{\{x(u,s)=x\}}W_{Y,Z|X,S}$, and $\epsilon_1 > \epsilon_2 > 0$ such that, $Q_Z = Q_0$ and $\mathbb{E}[g(X)] \leq \frac{G}{1+\epsilon_2}$.

Codebook Generation for Keys: Let $P_V(v) = \sum_s Q_S(s)P_{V|S}(v|s)$. For each block $j \in [1, B]$, randomly and independently generate $2^{r\tilde{R}}$ sequences $v^r(a_j)$, $a_j \in [1, 2^{r\tilde{R}}]$, each according to $\prod_{i=1}^r P_V(v_i)$. Partition the set of

indices $a_j \in \llbracket 1, 2^{r\tilde{R}} \rrbracket$ into bins $\mathcal{B}(t)$, $t \in \llbracket 1, 2^{rR_t} \rrbracket$ by using function $\varphi : V^r(a_j) \rightarrow \llbracket 1, 2^{rR_t} \rrbracket$ through random binning by choosing the value of $\varphi(V^r(a_j))$ independently and uniformly at random for every $V^r(a_j) \in \mathcal{V}^r$. For each block $j \in \llbracket 1, B \rrbracket$, create a function $\Phi : V^r(a_j) \rightarrow \llbracket 1, 2^{rR_k} \rrbracket$ through random binning by choosing the value of $\Phi(V^r(a_j))$ independently and uniformly at random for every $V^r(a_j) \in \mathcal{V}^r$. The key $k_j = \Phi(V^r(a_j))$ obtained in block $j \in \llbracket 1, B \rrbracket$ from the description of the channel state sequence $V^r(a_j)$ is used to assist the encoder in block $j + 2$.

Codebook Generation for Messages: For each block $j \in \llbracket 1, B \rrbracket$ and for each $m_j \in \llbracket 1, 2^{rR} \rrbracket$, $t_{j-1} \in \llbracket 1, 2^{rR_t} \rrbracket$, $k_{j-2} \in \llbracket 1, 2^{rR_k} \rrbracket$, randomly and independently generate $2^{rR'}$ codewords $u^r(m_j, t_{j-1}, k_{j-2}, \ell_j)$, $\ell_j \in \llbracket 1, 2^{rR'} \rrbracket$, according to $\prod_{i=1}^r p(u_i)$. These constitute the codebook \mathcal{C}_n . The indices $(m_j, t_{j-1}, k_{j-2}, \ell_j)$ can be viewed as a three layer binning. We define an ideal Probability Mass Function (PMF) for codebook \mathcal{C}_n , as an approximate distribution to facilitate the analysis

$$\begin{aligned} \Upsilon_{M_j, T_{j-1}, K_{j-2}, L_j, A_j, U^r, V_j^r, S_j^r, Z_j^r, K_{j-1}, T_j, K_j}^{(\mathcal{C}_n)}(m_j, t_{j-1}, k_{j-2}, \ell_j, a_j, \tilde{u}^r, \tilde{v}^r, s_j^r, z_j^r, k_{j-1}, t_j, k_j) \\ = 2^{-r(R+R_t+R_k+R'+\tilde{R})} \times \mathbb{1}_{\{u^r(m_j, t_{j-1}, k_{j-2}, \ell_j) = \tilde{u}^r\}} \times \mathbb{1}_{\{v^r(a_j) = \tilde{v}^r\}} \times P_{S|U, V}^{\otimes r}(s_j^r | \tilde{u}^r, \tilde{v}^r) \\ \times W_{Z|U, S}^{\otimes r}(z_j^r | \tilde{u}^r, s_j^r) \times 2^{-rR_k} \times \mathbb{1}_{\{\sigma(\tilde{v}^r) = t_j\}} \times \mathbb{1}_{\{\Phi(\tilde{v}^r) = k_j\}}, \end{aligned} \quad (116)$$

where $W_{Z|U, S}$ is the marginal distribution of $W_{Y, Z|U, S}$ defined in Theorem 3.

Encoding: In the first block, the encoder chooses the indices (m_1, t_0, k_{-1}) uniformly at random and then chooses the indices ℓ_1 and a_1 according to distribution with $j = 1$,

$$f(\ell_j, a_j | s_j^r, m_j, t_{j-1}, k_{j-2}) = \frac{P_{S|U, V}^{\otimes r}(s_j^r | u^r(m_j, t_{j-1}, k_{j-2}, \ell_j), v^r(a_j))}{\sum_{\ell_j' \in \llbracket 1, 2^{rR'} \rrbracket} \sum_{a_j' \in \llbracket 1, 2^{r\tilde{R}} \rrbracket} P_{S|U, V}^{\otimes r}(s_j^r | u^r(m_j, t_{j-1}, k_{j-2}, \ell_j'), v^r(a_j'))}, \quad (117)$$

where $P_{S|U, V}^{\otimes r}$ is defined from the ideal PMF in (116). Based on these indices, the encoder computes $u^r(m_1, t_0, k_{-1}, \ell_1)$ and $v^r(a_1)$ and transmits codeword x^r , where $x_i = x(u_i(m_1, t_0, k_{-1}, \ell_1), s_i)$. Simultaneously, it uses the description of its CSI $v^r(a_1)$ to generate a reconciliation index t_1 and a key k_1 to be used in the second and the third blocks, respectively.

In the second block, the encoder chooses the indices (m_2, k_0) uniformly at random and, using t_1 from the previous block, chooses the indices ℓ_2 and a_2 according to the likelihood encoder described in (117) with $j = 2$. Based on these indices the encoder computes $u^r(m_2, t_1, k_0, \ell_2)$ and $v^r(a_2)$ and transmits codeword x^r , where $x_i = x(u_i(m_2, t_1, k_0, \ell_2), s_i)$. Simultaneously, it uses the description of its CSI $v^r(a_2)$ to generate a reconciliation index t_2 and a key k_2 to be used in the third and the fourth block, respectively.

In block $j \in \llbracket 3, B \rrbracket$, to send the message m_j and reconciliation index t_{j-1} , generated in the previous block, according to the generated key k_{j-2} from the the block $j - 2$ and the CSI of the current block, the encoder selects indices ℓ_j and a_j from bin (m_j, t_{j-1}, k_{j-2}) according to the likelihood encoder described in (117). The encoder then transmits codeword x^r , where each coordinate of the transmitted signal is a function of the state, as well as the corresponding sample of the transmitter's codeword u_i , i.e., $x_i = x(u_i(m_j, t_{j-1}, k_{j-2}, \ell_j), s_i)$. Simultaneously, the encoder uses the description of its CSI $v^r(a_j)$ to generate a reconciliation index t_j and a key k_j to be used in the block $j + 1$ and the block $j + 2$, respectively.

Define

$$\Upsilon_{M_j, T_{j-1}, K_{j-2}, S_j^r, L_j, A_j, U^r, V_j^r, Z_j^r, K_{j-1}, T_j, K_j}^{(\mathcal{C}_n)}(m_j, t_{j-1}, k_{j-2}, s_j^r, \ell_j, a_j, \tilde{u}^r, \tilde{v}^r, z_j^r, k_{j-1}, t_j, k_j)$$

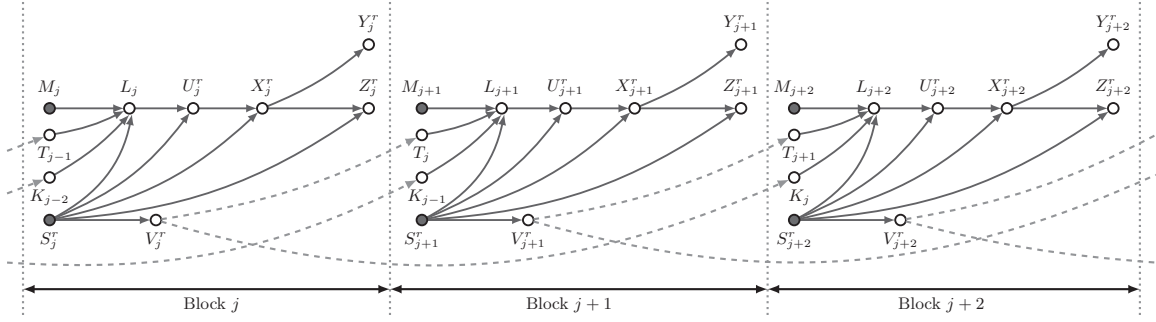

Fig. 8. Functional dependence graph for the block-Markov encoding scheme

$$\begin{aligned} &\triangleq 2^{-r(R+R_t+R_k)} \times Q_S^{\otimes r}(s_j^r) \times f(\ell_j, a_j | s_j^r, m_j, t_{j-1}, k_{j-2}) \times \mathbb{1}_{\{u^r(m_j, t_{j-1}, k_{j-2}, \ell_j) = \tilde{u}^r\}} \times \mathbb{1}_{\{v^r(a_j) = \tilde{v}^r\}} \\ &\quad \times W_{Z|U,S}^{\otimes r}(z_j^r | \tilde{u}^r, s_j^r) \times 2^{-rR_k} \times \mathbb{1}_{\{\sigma(\tilde{v}^r) = t_j\}} \times \mathbb{1}_{\{\Phi(\tilde{v}^r) = k_j\}}. \end{aligned} \quad (118)$$

For a given codebook \mathcal{C}_n , the induced joint distribution over the codebook (i.e. $P^{(\mathcal{C}_n)}$) satisfies

$$\|P_{M_j, T_{j-1}, K_{j-2}, S_j^r, L_j, A_j, U^r, V_j^r, Z_j^r, K_{j-1}, T_j, K_j}^{(\mathcal{C}_n)} - \Upsilon_{M_j, T_{j-1}, K_{j-2}, S_j^r, L_j, A_j, U^r, V_j^r, Z_j^r, K_{j-1}, T_j, K_j}^{(\mathcal{C}_n)}\|_1 \leq \epsilon. \quad (119)$$

This intermediate distribution $\Upsilon^{(\mathcal{C}_n)}$ approximates the true distribution $P^{(\mathcal{C}_n)}$ and will be used in the sequel for bounding purposes. Expression (119) holds because the main difference in $\Upsilon^{(\mathcal{C}_n)}$ is assuming the keys K_{j-2} , K_{j-1} and the reconciliation index T_{j-1} are uniformly distributed, which is made (arbitrarily) nearly uniform in $P^{(\mathcal{C}_n)}$ with appropriate control of rate.

Covert Analysis: We now show $\mathbb{E}_{\mathcal{C}_n}[\mathbb{D}(P_{Z^n}^{(\mathcal{C}_n)} || Q_Z^{\otimes n})] \xrightarrow[n \rightarrow \infty]{} 0$. From the expansion in (63), for every $j \in \llbracket 2, B \rrbracket$,

$$\begin{aligned} \mathbb{I}(Z_j^r; Z_{j+1}^{B,r}) &\leq \mathbb{I}(Z_j^r; K_{j-1}, K_j, T_j, Z_{j+1}^{B,r}) \\ &\stackrel{(a)}{=} \mathbb{I}(Z_j^r; K_{j-1}, K_j, T_j), \end{aligned} \quad (120)$$

where (a) holds because $Z_j^r - (K_{j-1}, K_j, T_j) - Z_{j+1}^{B,r}$ forms a Markov chain, as seen in the functional dependence graph depicted in Fig. 8.

$$\begin{aligned} \mathbb{I}(Z_j^r; K_{j-1}, K_j, T_j) &= \mathbb{D}(P_{Z_j^r, K_{j-1}, K_j, T_j}^{(\mathcal{C}_n)} || P_{Z_j^r}^{(\mathcal{C}_n)} P_{K_{j-1}, K_j, T_j}^{(\mathcal{C}_n)}) \\ &\leq \mathbb{D}(P_{Z_j^r, K_{j-1}, K_j, T_j}^{(\mathcal{C}_n)} || Q_Z^{\otimes r} Q_{K_{j-1}} Q_{K_j} Q_{T_j}), \end{aligned} \quad (121)$$

where $Q_{K_{j-1}} Q_{K_j} Q_{T_j}$ is the uniform distribution on $\llbracket 1, 2^{rR_k} \rrbracket \times \llbracket 1, 2^{rR_k} \rrbracket \times \llbracket 1, 2^{rR_t} \rrbracket$ and (b) follows from

$$\begin{aligned} \mathbb{D}(P_{Z_j^r, K_{j-1}, K_j, T_j}^{(\mathcal{C}_n)} || P_{Z_j^r}^{(\mathcal{C}_n)} P_{K_{j-1}, K_j, T_j}^{(\mathcal{C}_n)}) &= \mathbb{D}(P_{Z_j^r, K_{j-1}, K_j, T_j}^{(\mathcal{C}_n)} || Q_Z^{\otimes r} Q_{K_{j-1}} Q_{K_j} Q_{T_j}) \\ &\quad - \mathbb{D}(P_{Z_j^r}^{(\mathcal{C}_n)} || Q_Z^{\otimes r}) - \mathbb{D}(P_{K_{j-1}, K_j, T_j}^{(\mathcal{C}_n)} || Q_{K_{j-1}} Q_{K_j} Q_{T_j}). \end{aligned} \quad (122)$$

Therefore, by combining (63), (121), and (122)

$$\mathbb{D}(P_{Z^n}^{(\mathcal{C}_n)} || Q_Z^{\otimes n}) \leq 2 \sum_{j=1}^B \mathbb{D}(P_{Z_j^r, K_{j-1}, K_j, T_j}^{(\mathcal{C}_n)} || Q_Z^{\otimes r} Q_{K_{j-1}} Q_{K_j} Q_{T_j}). \quad (123)$$

Using the triangle inequality

$$\begin{aligned} &\mathbb{E}_{\mathcal{C}_n} \|P_{Z_j^r, K_{j-1}, K_j, T_j}^{(\mathcal{C}_n)} - Q_Z^{\otimes r} Q_{K_{j-1}} Q_{K_j} Q_{T_j}\|_1 \leq \\ &\mathbb{E}_{\mathcal{C}_n} \|P_{Z_j^r, K_{j-1}, K_j, T_j}^{(\mathcal{C}_n)} - \Gamma_{Z_j^r, K_{j-1}, K_j, T_j}^{(\mathcal{C}_n)}\|_1 + \mathbb{E}_{\mathcal{C}_n} \|\Gamma_{Z_j^r, K_{j-1}, K_j, T_j}^{(\mathcal{C}_n)} - Q_Z^{\otimes r} Q_{K_{j-1}} Q_{K_j} Q_{T_j}\|_1 \\ &\leq \mathbb{E}_{\mathcal{C}_n} \|P_{Z_j^r, K_{j-1}, K_j, T_j}^{(\mathcal{C}_n)} - \Upsilon_{Z_j^r, K_{j-1}, K_j, T_j}^{(\mathcal{C}_n)}\|_1 + \mathbb{E}_{\mathcal{C}_n} \|\Upsilon_{Z_j^r, K_{j-1}, K_j, T_j}^{(\mathcal{C}_n)} - \Gamma_{Z_j^r, K_{j-1}, K_j, T_j}^{(\mathcal{C}_n)}\|_1 \end{aligned}$$

$$+ \mathbb{E}_{\mathcal{C}_n} \|\Gamma_{Z_j^r, K_{j-1}, K_j, T_j}^{(\mathcal{C}_n)} - Q_Z^{\otimes r} Q_{K_{j-1}} Q_{K_j} Q_{T_j}\|_1. \quad (124)$$

From (119) the first term on the RHS of (124) goes to zero when n grows. To bound the second term on the RHS of (124)

$$\Gamma_{M_j, T_{j-1}, K_{j-2}}^{(\mathcal{C}_n)} = 2^{-r(R+R_t+R_k)} = P_{M_j, T_{j-1}, K_{j-2}}^{(\mathcal{C}_n)}, \quad (125)$$

$$\Gamma_{L_j, A_j | M_j, T_{j-1}, K_{j-2}, S_j^r}^{(\mathcal{C}_n)} = f^{LE}(\ell_j, a_j | s_j^r, m_j, t_{j-1}, k_{j-2}) = \Upsilon_{L_j, A_j | M_j, T_{j-1}, K_{j-2}, S_j^r}^{(\mathcal{C}_n)}, \quad (126)$$

$$\Gamma_{U^r | M_j, T_{j-1}, K_{j-2}, S_j^r, L_j, A_j}^{(\mathcal{C}_n)} = \mathbb{1}_{\{u^r(m_j, t_{j-1}, k_{j-2}, \ell_j) = \tilde{u}^r\}} = \Upsilon_{U^r | M_j, T_{j-1}, K_{j-2}, S_j^r, L_j, A_j}^{(\mathcal{C}_n)}, \quad (127)$$

$$\Gamma_{V^r | M_j, T_{j-1}, K_{j-2}, S_j^r, L_j, A_j, U^r}^{(\mathcal{C}_n)} = \mathbb{1}_{\{v^r(a_j) = \tilde{v}^r\}} = \Upsilon_{V^r | M_j, T_{j-1}, K_{j-2}, S_j^r, L_j, A_j, U^r}^{(\mathcal{C}_n)}, \quad (128)$$

$$\Gamma_{Z_j^r | M_j, T_{j-1}, K_{j-2}, S_j^r, L_j, A_j, U^r, V_j^r}^{(\mathcal{C}_n)} = W_{Z|U, S}^{\otimes r} = \Upsilon_{Z_j^r | M_j, T_{j-1}, K_{j-2}, S_j^r, L_j, A_j, U^r, V_j^r}^{(\mathcal{C}_n)}, \quad (129)$$

$$\Gamma_{K_{j-1} | M_j, T_{j-1}, K_{j-2}, S_j^r, L_j, A_j, U^r, V_j^r, Z_j^r}^{(\mathcal{C}_n)} = 2^{-rR_k} = \Upsilon_{K_{j-1} | M_j, T_{j-1}, K_{j-2}, S_j^r, L_j, A_j, U^r, V_j^r, Z_j^r}^{(\mathcal{C}_n)}, \quad (130)$$

$$\Gamma_{T_j | M_j, T_{j-1}, K_{j-2}, S_j^r, L_j, A_j, U^r, V_j^r, Z_j^r, K_{j-1}}^{(\mathcal{C}_n)} = \mathbb{1}_{\{\sigma(v_j^r) = t_j\}} = \Upsilon_{T_j | M_j, T_{j-1}, K_{j-2}, S_j^r, L_j, A_j, U^r, V_j^r, Z_j^r, K_{j-1}}^{(\mathcal{C}_n)}, \quad (131)$$

$$\Gamma_{K_j | M_j, T_{j-1}, K_{j-2}, S_j^r, L_j, A_j, U^r, V_j^r, Z_j^r, K_{j-1}, T_j}^{(\mathcal{C}_n)} = \mathbb{1}_{\{\Phi(v_j^r) = k_j\}} = \Upsilon_{K_j | M_j, T_{j-1}, K_{j-2}, S_j^r, L_j, A_j, U^r, V_j^r, Z_j^r, K_{j-1}, T_j}^{(\mathcal{C}_n)}, \quad (132)$$

where (126) follows from (117). Hence,

$$\begin{aligned} & \mathbb{E}_{\mathcal{C}_n} \|\Gamma_{Z_j^r, K_{j-1}, K_j, T_j}^{(\mathcal{C}_n)} - P_{Z_j^r, K_{j-1}, K_j, T_j}^{(\mathcal{C}_n)}\|_1 \\ & \leq \mathbb{E}_{\mathcal{C}_n} \|\Gamma_{M_j, T_{j-1}, K_{j-2}, S_j^r, L_j, A_j, U^r, V^r, Z_j^r, K_{j-1}, T_j, K_j}^{(\mathcal{C}_n)} - \Gamma_{M_j, T_{j-1}, K_{j-2}, S_j^r, L_j, A_j, U^r, V^r, Z_j^r, K_{j-1}, T_j, K_j}^{(\mathcal{C}_n)}\|_1 \\ & \stackrel{(a)}{=} \mathbb{E}_{\mathcal{C}_n} \|\Gamma_{M_j, T_{j-1}, K_{j-2}, S_j^r}^{(\mathcal{C}_n)} - \Gamma_{M_j, T_{j-1}, K_{j-2}, S_j^r}^{(\mathcal{C}_n)}\|_1 \\ & \stackrel{(b)}{=} \mathbb{E}_{\mathcal{C}_n} \|\Gamma_{S_j^r | M_j=1, T_{j-1}=1, K_{j-2}=1}^{\otimes r} - \Gamma_{S_j^r | M_j=1, T_{j-1}=1, K_{j-2}=1}^{(\mathcal{C}_n)}\|_1, \end{aligned} \quad (133)$$

where (a) follows from (126)-(132) and (b) follows from the symmetry of the codebook construction with respect to M_j , T_{j-1} , and K_{j-2} and (125). Based on [25, Theorem 2] the RHS of (133) vanishes if

$$R' > \mathbb{I}(U; S), \quad (134)$$

$$\tilde{R} > \mathbb{I}(V; S), \quad (135)$$

$$R' + \tilde{R} > \mathbb{I}(U, V; S). \quad (136)$$

We now proceed to bound the third term on the RHS of (124). First, consider the marginal

$$\begin{aligned} \Gamma_{Z_j^r, K_{j-1}, K_j, T_j}^{(\mathcal{C}_n)}(z_j^r, k_{j-1}, k_j, t_j) &= \sum_{m_j} \sum_{t_{j-1}} \sum_{k_{j-2}} \sum_{\ell_j} \sum_{a_j} \sum_{s_j^r} \frac{1}{2^{r(R+R_t+2R_k+R'+\tilde{R})}} \\ & \times P_{S|U, V}^{\otimes r}(s_j^r | u^r(m_j, t_{j-1}, k_{j-2}, \ell_j), v^r(a_j)) \times W_{Z|U, S}^{\otimes r}(z_j^r | u^r(m_j, t_{j-1}, k_{j-2}, \ell_j), s_j^r) \\ & \times \mathbb{1}_{\{\sigma(v^r(a_j)) = t_j\}} \times \mathbb{1}_{\{\Phi(v^r(a_j)) = k_j\}}. \end{aligned} \quad (137)$$

Using Pinsker's inequality, it is sufficient to bound $\mathbb{E}_{\mathcal{C}_n} [\mathbb{D}(\Gamma_{Z_j^r, K_{j-1}, K_j, T_j}^{(\mathcal{C}_n)} \| Q_Z^{\otimes r} Q_{K_{j-1}} Q_{K_j} Q_{T_j})]$ as follows

$$\begin{aligned} & \mathbb{E}_{\mathcal{C}_n} [\mathbb{D}(\Gamma_{Z_j^r, K_{j-1}, K_j, T_j}^{(\mathcal{C}_n)} \| Q_Z^{\otimes r} Q_{K_{j-1}} Q_{K_j} Q_{T_j})] \\ &= \mathbb{E}_{\mathcal{C}_n} \left[\sum_{(z_j^r, k_{j-1}, k_j, t_j)} \Gamma^{(\mathcal{C}_n)}(z_j^r, k_{j-1}, k_j, t_j) \log \left(\frac{\Gamma^{(\mathcal{C}_n)}(z_j^r, k_{j-1}, k_j, t_j)}{Q_Z^{\otimes r}(z_j^r) Q_{K_{j-1}}(k_{j-1}) Q_{K_j}(k_j) Q_{T_j}(t_j)} \right) \right] \\ &= \mathbb{E}_{\mathcal{C}_n} \left[\sum_{(z_j^r, k_{j-1}, k_j, t_j)} \sum_{m_j} \sum_{t_{j-1}} \sum_{k_{j-2}} \sum_{\ell_j} \sum_{a_j} \sum_{s_j^r} \frac{1}{2^{r(R+R_t+2R_k+R'+\tilde{R})}} \times P_{S|U, V}^{\otimes r}(s_j^r | u^r(m_j, t_{j-1}, k_{j-2}, \ell_j), v_j^r(a_j)) \right] \end{aligned}$$

$$\begin{aligned}
& \times W_{Z|U,S}^{\otimes r}(z_j^r | u^r(m_j, t_{j-1}, k_{j-2}, \ell_j), s_j^r) \times \mathbf{1}_{\{\sigma(v^r(a_j))=t_j\}} \times \mathbf{1}_{\{\Phi(v^r(a_j))=k_j\}} \\
& \times \log \left(\frac{1}{2^{r(R+R_t+R_k+R'+\tilde{R}-R_T-R_K)} \times Q_Z^{\otimes r}(z_j^r)} \right. \\
& \times \sum_{\tilde{m}_j} \sum_{\tilde{t}_{j-1}} \sum_{\tilde{k}_{j-2}} \sum_{\tilde{\ell}_j} \sum_{\tilde{a}_j} \sum_{\tilde{s}_j^r} P_{S|U,V}^{\otimes r}(\tilde{s}_j^r | u^r(\tilde{m}_j, \tilde{t}_{j-1}, \tilde{k}_{j-2}, \tilde{\ell}_j), v_j^r(\tilde{a}_j)) \\
& \left. \times W_{Z|U,S}^{\otimes r}(z_j^r | u^r(\tilde{m}_j, \tilde{t}_{j-1}, \tilde{k}_{j-2}, \tilde{\ell}_j), \tilde{s}_j^r) \times \mathbf{1}_{\{\sigma(v^r(\tilde{a}_j))=t_j\}} \times \mathbf{1}_{\{\Phi(v^r(\tilde{a}_j))=k_j\}} \right) \\
& \stackrel{(a)}{\leq} \sum_{(z_j^r, k_{j-1}, k_j, t_j)} \sum_{m_j} \sum_{t_{j-1}} \sum_{k_{j-2}} \sum_{\ell_j} \sum_{a_j} \frac{1}{2^{r(R+R_t+2R_k+R'+\tilde{R})}} \sum_{s_j^r} \sum_{u^r, v_j^r} \Gamma_{U^r, V^r, S^r, Z^r}^{(C_n)}(u^r(m_j, t_{j-1}, k_{j-2}, \ell_j), v_j^r(a_j), s_j^r, z_j^r) \\
& \times \mathbb{E}_{\sigma(v_j^r(a_j))} [\mathbf{1}_{\{\sigma(v_j^r(a_j))=t_j\}}] \times \mathbb{E}_{\Phi(v_j^r(a_j))} [\mathbf{1}_{\{\Phi(v_j^r(a_j))=k_j\}}] \\
& \times \log \mathbb{E}_{\setminus(m_j, t_{j-1}, k_{j-2}, \ell_j, a_j), \setminus(\sigma(v_j^r(a_j)), \Phi(v_j^r(a_j)))} \left[\frac{1}{2^{r(R+R_t+R_k+R'+\tilde{R}-R_T-R_K)} \times Q_Z^{\otimes r}(z_j^r)} \right. \tag{138} \\
& \times \sum_{\tilde{m}_j} \sum_{\tilde{t}_{j-1}} \sum_{\tilde{k}_{j-2}} \sum_{\tilde{\ell}_j} \sum_{\tilde{a}_j} \sum_{\tilde{s}_j^r} P_{S|U,V}^{\otimes r}(\tilde{s}_j^r | u^r(\tilde{m}_j, \tilde{t}_{j-1}, \tilde{k}_{j-2}, \tilde{\ell}_j), v_j^r(\tilde{a}_j)) \times W_{Z|U,S}^{\otimes r}(z_j^r | u^r(\tilde{m}_j, \tilde{t}_{j-1}, \tilde{k}_{j-2}, \tilde{\ell}_j), \tilde{s}_j^r) \\
& \left. \times \mathbf{1}_{\{\sigma(v^r(\tilde{a}_j))=t_j\}} \times \mathbf{1}_{\{\Phi(v^r(\tilde{a}_j))=k_j\}} \right] \\
& \stackrel{(b)}{\leq} \sum_{(z_j^r, k_{j-1}, k_j, t_j)} \sum_{m_j} \sum_{t_{j-1}} \sum_{k_{j-2}} \sum_{\ell_j} \sum_{a_j} \frac{1}{2^{r(R+R_t+2R_k+R'+\tilde{R})}} \sum_{s_j^r} \sum_{u^r, v_j^r} \Gamma_{U^r, V^r, S^r, Z^r}^{(C_n)}(u^r(m_j, t_{j-1}, k_{j-2}, \ell_j), v_j^r(a_j), s_j^r, z_j^r) \\
& \times \frac{1}{2^{rR_T}} \times \frac{1}{2^{rR_K}} \times \log \left(\frac{P_{S|U,V}^{\otimes r}(s_j^r | u^r(m_j, t_{j-1}, k_{j-2}, \ell_j), v_j^r(a_j)) \times W_{Z|U,S}^{\otimes r}(z_j^r | u^r(m_j, t_{j-1}, k_{j-2}, \ell_j), s_j^r)}{2^{r(R+R_t+R_k+R'+\tilde{R}-R_T-R_K)} \times Q_Z^{\otimes r}(z_j^r)} \right) \\
& + \mathbb{E}_{\setminus(m_j, t_{j-1}, k_{j-2}, \ell_j)} \left[\frac{1}{2^{r(R+R_t+R_k+R'+\tilde{R}-R_T-R_K)} \times Q_Z^{\otimes r}(z_j^r)} \right. \\
& \times \sum_{(\tilde{m}_j, \tilde{t}_{j-1}, \tilde{k}_{j-2}, \tilde{\ell}_j) \neq (m_j, t_{j-1}, k_{j-2}, \ell_j)} P_{S|U,V}^{\otimes r}(s_j^r | u^r(\tilde{m}_j, \tilde{t}_{j-1}, \tilde{k}_{j-2}, \tilde{\ell}_j), v_j^r(a_j)) \times W_{Z|U,S}^{\otimes r}(z_j^r | u^r(\tilde{m}_j, \tilde{t}_{j-1}, \tilde{k}_{j-2}, \tilde{\ell}_j), s_j^r) \\
& \left. + \frac{\sum_{\tilde{s}_j^r \neq s_j^r} P_{S|U,V}^{\otimes r}(\tilde{s}_j^r | u^r(m_j, t_{j-1}, k_{j-2}, \ell_j), v_j^r(a_j)) \times W_{Z|U,S}^{\otimes r}(z_j^r | u^r(m_j, t_{j-1}, k_{j-2}, \ell_j), \tilde{s}_j^r)}{2^{r(R+R_t+R_k+R'+\tilde{R}-R_T-R_K)} \times Q_Z^{\otimes r}(z_j^r)} \right] \\
& + \mathbb{E}_{\setminus(a_j, \sigma(v_j^r(a_j)), \Phi(v_j^r(a_j)))} \left[\frac{1}{2^{r(R+R_t+R_k+R'+\tilde{R}-R_T-R_K)} \times Q_Z^{\otimes r}(z_j^r)} \right. \\
& \times \sum_{\tilde{a}_j \neq a_j} \sum_{\tilde{s}_j^r \neq s_j^r} P_{S|U,V}^{\otimes r}(\tilde{s}_j^r | u^r(m_j, t_{j-1}, k_{j-2}, \ell_j), v_j^r(\tilde{a}_j)) \times W_{Z|U,S}^{\otimes r}(z_j^r | u^r(m_j, t_{j-1}, k_{j-2}, \ell_j), \tilde{s}_j^r) \\
& \left. \times \mathbf{1}_{\{\sigma(v_j^r(\tilde{a}_j))=t_j\}} \times \mathbf{1}_{\{\Phi(v_j^r(\tilde{a}_j))=k_j\}} \right] \\
& + \mathbb{E}_{\setminus(a_j, \sigma(v_j^r(a_j)), \Phi(v_j^r(a_j)))} \left[\frac{1}{2^{r(R+R_t+R_k+R'+\tilde{R}-R_T-R_K)} \times Q_Z^{\otimes r}(z_j^r)} \right. \\
& \times \sum_{\tilde{a}_j \neq a_j} P_{S|U,V}^{\otimes r}(s_j^r | u^r(m_j, t_{j-1}, k_{j-2}, \ell_j), v_j^r(\tilde{a}_j)) \times W_{Z|U,S}^{\otimes r}(z_j^r | u^r(m_j, t_{j-1}, k_{j-2}, \ell_j), s_j^r) \\
& \left. \times \mathbf{1}_{\{\sigma(v_j^r(\tilde{a}_j))=t_j\}} \times \mathbf{1}_{\{\Phi(v_j^r(\tilde{a}_j))=k_j\}} \right]
\end{aligned}$$

$$\begin{aligned}
& \times \mathbb{1}_{\{\sigma(v_j^r(\tilde{a}_j))=t_j\}} \times \mathbb{1}_{\{\Phi(v_j^r(\tilde{a}_j))=k_j\}} \Big] \\
& + \mathbb{E}_{\setminus(m_j, t_{j-1}, k_{j-2}, \ell_j)} \left[\frac{1}{2^{r(R+R_t+R_k+R'+\tilde{R}-R_T-R_K)} \times Q_Z^{\otimes r}(z_j^r)} \right. \\
& \times \sum_{(\tilde{m}_j, \tilde{t}_{j-1}, \tilde{k}_{j-2}, \tilde{\ell}_j) \neq (m_j, t_{j-1}, k_{j-2}, \ell_j)} \sum_{\tilde{s}_j^r \neq s_j^r} P_{S|U,V}^{\otimes r}(\tilde{s}_j^r | u^r(\tilde{m}_j, \tilde{t}_{j-1}, \tilde{k}_{j-2}, \tilde{\ell}_j), v_j^r(a_j)) \\
& \times \left. W_{Z|U,S}^{\otimes r}(z_j^r | u^r(\tilde{m}_j, \tilde{t}_{j-1}, \tilde{k}_{j-2}, \tilde{\ell}_j), \tilde{s}_j^r) \right] \\
& + \mathbb{E}_{\setminus(m_j, t_{j-1}, k_{j-2}, \ell_j, a_j), \setminus(\sigma(v_j^r(a_j)), \Phi(v_j^r(a_j)))} \left[\frac{1}{2^{r(R+R_t+R_k+R'+\tilde{R}-R_T-R_K)} \times Q_Z^{\otimes r}(z_j^r)} \right. \\
& \times \sum_{(\tilde{m}_j, \tilde{t}_{j-1}, \tilde{k}_{j-2}, \tilde{\ell}_j) \neq (m_j, t_{j-1}, k_{j-2}, \ell_j)} \sum_{\tilde{a}_j \neq a_j} \sum_{\tilde{s}_j^r} P_{S|U,V}^{\otimes r}(\tilde{s}_j^r | u^r(\tilde{m}_j, \tilde{t}_{j-1}, \tilde{k}_{j-2}, \tilde{\ell}_j), v_j^r(\tilde{a}_j)) \times \\
& \left. W_{Z|U,S}^{\otimes r}(z_j^r | u^r(\tilde{m}_j, \tilde{t}_{j-1}, \tilde{k}_{j-2}, \tilde{\ell}_j), \tilde{s}_j^r) \times \mathbb{1}_{\{\sigma(v_j^r(\tilde{a}_j))=t_j\}} \times \mathbb{1}_{\{\Phi(v_j^r(\tilde{a}_j))=k_j\}} \right] \\
& \stackrel{(c)}{\leq} \sum_{(z_j^r, k_{j-1}, k_j, t_j)} \sum_{m_j} \sum_{t_{j-1}} \sum_{k_{j-2}} \sum_{\ell_j} \sum_{a_j} \frac{1}{2^{r(R+R_t+2R_k+R'+\tilde{R}+R_T+R_K)}} \\
& \times \sum_{s_j^r} \sum_{u^r, v_j^r} \Gamma_{U^r, V^r, S^r, Z^r}^{(C_n)}(u^r(m_j, t_{j-1}, k_{j-2}, \ell_j), v_j^r(a_j), s_j^r, z_j^r) \\
& \times \log \left(\frac{P_{S|U,V}^{\otimes r}(s_j^r | u^r(m_j, t_{j-1}, k_{j-2}, \ell_j), v_j^r(a_j)) \times W_{Z|U,S}^{\otimes r}(z_j^r | u^r(m_j, t_{j-1}, k_{j-2}, \ell_j), s_j^r)}{2^{r(R+R_t+R_k+R'+\tilde{R}-R_T-R_K)} \times Q_Z^{\otimes r}(z_j^r)} \right. \\
& + \sum_{(\tilde{m}_j, \tilde{t}_{j-1}, \tilde{k}_{j-2}, \tilde{\ell}_j) \neq (m_j, t_{j-1}, k_{j-2}, \ell_j)} \frac{P_{S|V}^{\otimes r}(s_j^r | v_j^r(a_j)) \times W_{Z|S}^{\otimes r}(z_j^r | s_j^r)}{2^{r(R+R_t+R_k+R'+\tilde{R}-R_T-R_K)} \times Q_Z^{\otimes r}(z_j^r)} \\
& + \sum_{\tilde{s}_j^r \neq s_j^r} \frac{P_{S|U,V}^{\otimes r}(\tilde{s}_j^r | u^r(m_j, t_{j-1}, k_{j-2}, \ell_j), v_j^r(a_j)) \times W_{Z|U,S}^{\otimes r}(z_j^r | u^r(m_j, t_{j-1}, k_{j-2}, \ell_j), \tilde{s}_j^r)}{2^{r(R+R_t+R_k+R'+\tilde{R}-R_T-R_K)} \times Q_Z^{\otimes r}(z_j^r)} \\
& + \sum_{\tilde{a}_j \neq a_j} \sum_{\tilde{s}_j^r \neq s_j^r} \frac{P_{S|U}^{\otimes r}(\tilde{s}_j^r | u^r(m_j, t_{j-1}, k_{j-2}, \ell_j)) \times W_{Z|U,S}^{\otimes r}(z_j^r | u^r(m_j, t_{j-1}, k_{j-2}, \ell_j), \tilde{s}_j^r)}{2^{r(R+R_t+R_k+R'+\tilde{R})} \times Q_Z^{\otimes r}(z_j^r)} \\
& + \sum_{\tilde{a}_j \neq a_j} \frac{P_{S|U}^{\otimes r}(s_j^r | u^r(m_j, t_{j-1}, k_{j-2}, \ell_j)) \times W_{Z|U,S}^{\otimes r}(z_j^r | u^r(m_j, t_{j-1}, k_{j-2}, \ell_j), s_j^r)}{2^{r(R+R_t+R_k+R'+\tilde{R})} \times Q_Z^{\otimes r}(z_j^r)} \\
& + \left. \sum_{(\tilde{m}_j, \tilde{t}_{j-1}, \tilde{k}_{j-2}, \tilde{\ell}_j) \neq (m_j, t_{j-1}, k_{j-2}, \ell_j)} \sum_{\tilde{s}_j^r \neq s_j^r} \frac{P_{S|V}^{\otimes r}(\tilde{s}_j^r | v_j^r(a_j)) \times W_{Z|S}^{\otimes r}(z_j^r | \tilde{s}_j^r)}{2^{r(R+R_t+R_k+R'+\tilde{R}-R_T-R_K)} \times Q_Z^{\otimes r}(z_j^r)} + 1 \right) \\
& \triangleq \Psi_1 + \Psi_2, \tag{139}
\end{aligned}$$

where (a) follows from Jensen's inequality, (b) and (c) hold because $\mathbb{1}_{\{\Phi(v_j^r)=k_j\}} \leq 1$. We defined Ψ_1 and Ψ_2 as

$$\begin{aligned}
\Psi_1 &= \sum_{(k_{j-1}, k_j, t_j)} \sum_{m_j} \sum_{t_{j-1}} \sum_{k_{j-2}} \sum_{\ell_j} \sum_{a_j} \frac{1}{2^{r(R+R_t+2R_k+R'+\tilde{R}+R_T+R_K)}} \\
& \times \sum_{(u^r(m_j, t_{j-1}, k_{j-2}, \ell_j), v_j^r(a_j), s_j^r, z_j^r) \in T_{\varepsilon}^{(n)}} \Gamma_{U^r, V^r, S^r, Z^r}^{(C_n)}(u^r(m_j, t_{j-1}, k_{j-2}, \ell_j), v_j^r(a_j), s_j^r, z_j^r)
\end{aligned}$$

$$\begin{aligned}
& \times \log \left(\frac{P_{S|U,V}^{\otimes r}(s_j^r | u^r(m_j, t_{j-1}, k_{j-2}, \ell_j), v_j^r(a_j)) \times W_{Z|U,S}^{\otimes r}(z_j^r | u^r(m_j, t_{j-1}, k_{j-2}, \ell_j), s_j^r)}{2^{r(R+R_t+R_k+R'+\tilde{R}-R_T-R_K)} \times Q_Z^{\otimes r}(z_j^r)} \right. \\
& + \sum_{(\tilde{m}_j, \tilde{t}_{j-1}, \tilde{k}_{j-2}, \tilde{\ell}_j) \neq (m_j, t_{j-1}, k_{j-2}, \ell_j)} \frac{P_{S|V}^{\otimes r}(s_j^r | v_j^r(a_j)) \times W_{Z|S}^{\otimes r}(z_j^r | s_j^r)}{2^{r(R+R_t+R_k+R'+\tilde{R}-R_T-R_K)} \times Q_Z^{\otimes r}(z_j^r)} \\
& + \sum_{\tilde{s}_j^r \neq s_j^r} \frac{P_{S|U,V}^{\otimes r}(\tilde{s}_j^r | u^r(m_j, t_{j-1}, k_{j-2}, \ell_j), v_j^r(a_j)) \times W_{Z|U,S}^{\otimes r}(z_j^r | u^r(m_j, t_{j-1}, k_{j-2}, \ell_j), \tilde{s}_j^r)}{2^{r(R+R_t+R_k+R'+\tilde{R}-R_T-R_K)} \times Q_Z^{\otimes r}(z_j^r)} \\
& + \sum_{\tilde{a}_j \neq a_j} \sum_{\tilde{s}_j^r \neq s_j^r} \frac{P_{S|U}^{\otimes r}(\tilde{s}_j^r | u^r(m_j, t_{j-1}, k_{j-2}, \ell_j)) \times W_{Z|U,S}^{\otimes r}(z_j^r | u^r(m_j, t_{j-1}, k_{j-2}, \ell_j), \tilde{s}_j^r)}{2^{r(R+R_t+R_k+R'+\tilde{R})} \times Q_Z^{\otimes r}(z_j^r)} \\
& + \sum_{\tilde{a}_j \neq a_j} \frac{P_{S|U}^{\otimes r}(s_j^r | u^r(m_j, t_{j-1}, k_{j-2}, \ell_j)) \times W_{Z|U,S}^{\otimes r}(z_j^r | u^r(m_j, t_{j-1}, k_{j-2}, \ell_j), s_j^r)}{2^{r(R+R_t+R_k+R'+\tilde{R})} \times Q_Z^{\otimes r}(z_j^r)} \\
& + \sum_{(\tilde{m}_j, \tilde{t}_{j-1}, \tilde{k}_{j-2}, \tilde{\ell}_j) \neq (m_j, t_{j-1}, k_{j-2}, \ell_j)} \sum_{\tilde{s}_j^r \neq s_j^r} \frac{P_{S|V}^{\otimes r}(\tilde{s}_j^r | v_j^r(a_j)) \times W_{Z|S}^{\otimes r}(z_j^r | \tilde{s}_j^r)}{2^{r(R+R_t+R_k+R'+\tilde{R}-R_T-R_K)} \times Q_Z^{\otimes r}(z_j^r)} + 1 \Big) \\
& \leq \sum_{(k_{j-1}, k_j, t_j)} \sum_{m_j} \sum_{t_{j-1}} \sum_{k_{j-2}} \sum_{\ell_j} \sum_{a_j} \frac{1}{2^{r(R+R_t+2R_k+R'+\tilde{R}+R_T+R_K)}} \\
& \times \sum_{(u^r(m_j, t_{j-1}, k_{j-2}, \ell_j), v_j^r(a_j), s_j^r, z_j^r) \in T_\epsilon^{(n)}} \Gamma_{U^r, V^r, S^r, Z^r}^{(C_n)}(u^r(m_j, t_{j-1}, k_{j-2}, \ell_j), v_j^r(a_j), s_j^r, z_j^r) \\
& \times \log \left(\frac{P_{S|U,V}^{\otimes r}(s_j^r | u^r(m_j, t_{j-1}, k_{j-2}, \ell_j), v_j^r(a_j)) \times W_{Z|U,S}^{\otimes r}(z_j^r | u^r(m_j, t_{j-1}, k_{j-2}, \ell_j), s_j^r)}{2^{r(R+R_t+R_k+R'+\tilde{R}-R_T-R_K)} \times Q_Z^{\otimes r}(z_j^r)} \right. \\
& + \frac{P_{S|V}^{\otimes r}(s_j^r | v_j^r(a_j)) \times W_{Z|S}^{\otimes r}(z_j^r | s_j^r)}{2^{r(\tilde{R}-R_T-R_K)} \times Q_Z^{\otimes r}(z_j^r)} + \frac{W_{Z|U}^{\otimes r}(z_j^r | u^r(m_j, t_{j-1}, k_{j-2}, \ell_j))}{2^{r(R+R_t+R_k+R'+\tilde{R}-R_T-R_K)} \times Q_Z^{\otimes r}(z_j^r)} + \frac{W_{Z|U}^{\otimes r}(z_j^r | u^r(m_j, t_{j-1}, k_{j-2}, \ell_j))}{2^{r(R+R_t+R_k+R')} \times Q_Z^{\otimes r}(z_j^r)} \\
& + \frac{P_{S|U}^{\otimes r}(s_j^r | u^r(m_j, t_{j-1}, k_{j-2}, \ell_j)) \times W_{Z|U,S}^{\otimes r}(z_j^r | u^r(m_j, t_{j-1}, k_{j-2}, \ell_j), s_j^r)}{2^{r(R+R_t+R_k+R')} \times Q_Z^{\otimes r}(z_j^r)} + \frac{Q_Z^{\otimes r}(z_j^r)}{2^{r(\tilde{R}-R_T-R_K)} \times Q_Z^{\otimes r}(z_j^r)} + 1 \Big) \\
& \leq \log \left(\frac{2^{r(R_T+R_K)} \times 2^{-r(1-\epsilon)\mathbb{H}(S|U,V)} \times 2^{-r(1-\epsilon)\mathbb{H}(Z|U,S)}}{2^{r(R+R_t+R_k+R'+\tilde{R})} \times 2^{-r(1+\epsilon)\mathbb{H}(Z)}} + \frac{2^{r(R_T+R_K)} \times 2^{-r(1-\epsilon)\mathbb{H}(S|V)} \times 2^{-r(1-\epsilon)\mathbb{H}(Z|S)}}{2^r \tilde{R} \times 2^{-r(1+\epsilon)\mathbb{H}(Z)}} \right. \\
& + \frac{2^{r(R_T+R_K)} \times 2^{-r(1-\epsilon)\mathbb{H}(Z|U)}}{2^{r(R+R_t+R_k+R'+\tilde{R})} \times 2^{-r(1+\epsilon)\mathbb{H}(Z)}} + \frac{2^{-r(1-\epsilon)\mathbb{H}(Z|U)}}{2^{r(R+R_t+R_k+R')} \times 2^{-r(1+\epsilon)\mathbb{H}(Z)}} \\
& + \left. \frac{2^{-r(1-\epsilon)\mathbb{H}(S|U)} \times 2^{-r(1-\epsilon)\mathbb{H}(Z|U,S)}}{2^{r(R+R_t+R_k+R')} \times 2^{-r(1+\epsilon)\mathbb{H}(Z)}} + \frac{2^{r(R_T+R_K)} \times 2^{-r(1-\epsilon)\mathbb{H}(Z)}}{2^r \tilde{R} \times 2^{-r(1+\epsilon)\mathbb{H}(Z)}} + 1 \right) \tag{140} \\
\Psi_2 & = \sum_{(k_{j-1}, k_j, t_j)} \sum_{m_j} \sum_{t_{j-1}} \sum_{k_{j-2}} \sum_{\ell_j} \sum_{a_j} \frac{1}{2^{r(R+R_t+2R_k+R'+\tilde{R}+R_T+R_K)}} \\
& \times \sum_{(u^r(m_j, t_{j-1}, k_{j-2}, \ell_j), v_j^r(a_j), s_j^r, z_j^r) \notin T_\epsilon^{(n)}} \Gamma_{U^r, V^r, S^r, Z^r}^{(C_n)}(u^r(m_j, t_{j-1}, k_{j-2}, \ell_j), v_j^r(a_j), s_j^r, z_j^r) \\
& \times \log \left(\frac{P_{S|U,V}^{\otimes r}(s_j^r | u^r(m_j, t_{j-1}, k_{j-2}, \ell_j), v_j^r(a_j)) \times W_{Z|U,S}^{\otimes r}(z_j^r | u^r(m_j, t_{j-1}, k_{j-2}, \ell_j), s_j^r)}{2^{r(R+R_t+R_k+R'+\tilde{R}-R_T-R_K)} \times Q_Z^{\otimes r}(z_j^r)} \right. \\
& + \sum_{(\tilde{m}_j, \tilde{t}_{j-1}, \tilde{k}_{j-2}, \tilde{\ell}_j) \neq (m_j, t_{j-1}, k_{j-2}, \ell_j)} \frac{P_{S|V}^{\otimes r}(s_j^r | v_j^r(a_j)) \times W_{Z|S}^{\otimes r}(z_j^r | s_j^r)}{2^{r(R+R_t+R_k+R'+\tilde{R}-R_T-R_K)} \times Q_Z^{\otimes r}(z_j^r)}
\end{aligned}$$

$$\begin{aligned}
& + \sum_{\tilde{s}_j^r \neq s_j^r} \frac{P_{S|U,V}^{\otimes r}(\tilde{s}_j^r | u^r(m_j, t_{j-1}, k_{j-2}, \ell_j), v_j^r(a_j)) \times W_{Z|U,S}^{\otimes r}(z_j^r | u^r(m_j, t_{j-1}, k_{j-2}, \ell_j), \tilde{s}_j^r)}{2^{r(R+R_t+R_k+R'+\tilde{R}-R_T-R_K)} \times Q_Z^{\otimes r}(z_j^r)} \\
& + \sum_{\tilde{a}_j \neq a_j} \sum_{\tilde{s}_j^r \neq s_j^r} \frac{P_{S|U}^{\otimes r}(\tilde{s}_j^r | u^r(m_j, t_{j-1}, k_{j-2}, \ell_j)) \times W_{Z|U,S}^{\otimes r}(z_j^r | u^r(m_j, t_{j-1}, k_{j-2}, \ell_j), \tilde{s}_j^r)}{2^{r(R+R_t+R_k+R'+\tilde{R})} \times Q_Z^{\otimes r}(z_j^r)} \\
& + \sum_{\tilde{a}_j \neq a_j} \frac{P_{S|U}^{\otimes r}(s_j^r | u^r(m_j, t_{j-1}, k_{j-2}, \ell_j)) \times W_{Z|U,S}^{\otimes r}(z_j^r | u^r(m_j, t_{j-1}, k_{j-2}, \ell_j), s_j^r)}{2^{r(R+R_t+R_k+R'+\tilde{R})} \times Q_Z^{\otimes r}(z_j^r)} \\
& + \left(\sum_{(\tilde{m}_j, \tilde{t}_{j-1}, \tilde{k}_{j-2}, \tilde{\ell}_j) \neq (m_j, t_{j-1}, k_{j-2}, \ell_j)} \sum_{\tilde{s}_j^r \neq s_j^r} \frac{P_{S|V}^{\otimes r}(\tilde{s}_j^r | v_j^r(a_j)) \times W_{Z|S}^{\otimes r}(z_j^r | \tilde{s}_j^r)}{2^{r(R+R_t+R_k+R'+\tilde{R}-R_T-R_K)} \times Q_Z^{\otimes r}(z_j^r)} + 1 \right) \\
& \leq \sum_{(k_{j-1}, k_j, t_j)} \sum_{m_j} \sum_{t_{j-1}} \sum_{k_{j-2}} \sum_{\ell_j} \sum_{a_j} \frac{1}{2^{r(R+R_t+2R_k+R'+\tilde{R}+R_T+R_K)}} \\
& \times \sum_{(u^r(m_j, t_{j-1}, k_{j-2}, \ell_j), v_j^r(a_j), s_j^r, z_j^r) \notin T_\epsilon^{(n)}} \Gamma_{U^r, V^r, S^r, Z^r}^{(C_n)}(u^r(m_j, t_{j-1}, k_{j-2}, \ell_j), v_j^r(a_j), s_j^r, z_j^r) \\
& \times \log \left(\frac{P_{S|U,V}^{\otimes r}(s_j^r | u^r(m_j, t_{j-1}, k_{j-2}, \ell_j), v_j^r(a_j)) \times W_{Z|U,S}^{\otimes r}(z_j^r | u^r(m_j, t_{j-1}, k_{j-2}, \ell_j), s_j^r)}{2^{r(R+R_t+R_k+R'+\tilde{R}-R_T-R_K)} \times Q_Z^{\otimes r}(z_j^r)} \right. \\
& + \frac{P_{S|V}^{\otimes r}(s_j^r | v_j^r(a_j)) \times W_{Z|S}^{\otimes r}(z_j^r | s_j^r)}{2^{r(\tilde{R}-R_T-R_K)} \times Q_Z^{\otimes r}(z_j^r)} + \frac{W_{Z|U}^{\otimes r}(z_j^r | u^r(m_j, t_{j-1}, k_{j-2}, \ell_j))}{2^{r(R+R_t+R_k+R'+\tilde{R}-R_T-R_K)} \times Q_Z^{\otimes r}(z_j^r)} + \frac{W_{Z|U}^{\otimes r}(z_j^r | u^r(m_j, t_{j-1}, k_{j-2}, \ell_j))}{2^{r(R+R_t+R_k+R')} \times Q_Z^{\otimes r}(z_j^r)} \\
& \left. + \frac{P_{S|U}^{\otimes r}(s_j^r | u^r(m_j, t_{j-1}, k_{j-2}, \ell_j)) \times W_{Z|U,S}^{\otimes r}(z_j^r | u^r(m_j, t_{j-1}, k_{j-2}, \ell_j), s_j^r)}{2^{r(R+R_t+R_k+R')} \times Q_Z^{\otimes r}(z_j^r)} + \frac{Q_Z^{\otimes r}(z_j^r)}{2^{r(\tilde{R}-R_T-R_K)} \times Q_Z^{\otimes r}(z_j^r)} + 1 \right) \\
& \leq \log \left(\frac{2^{r(R_T+R_K)} \times 2^{-r(1-\epsilon)\mathbb{H}(S|U,V)} \times 2^{-r(1-\epsilon)\mathbb{H}(Z|U,S)}}{2^{r(R+R_t+R_k+R'+\tilde{R})} \times 2^{-r(1+\epsilon)\mathbb{H}(Z)}} + \frac{2^{r(R_T+R_K)} \times 2^{-r(1-\epsilon)\mathbb{H}(S|V)} \times 2^{-r(1-\epsilon)\mathbb{H}(Z|S)}}{2^{r\tilde{R}} \times 2^{-r(1+\epsilon)\mathbb{H}(Z)}} \right. \\
& + \frac{2^{r(R_T+R_K)} \times 2^{-r(1-\epsilon)\mathbb{H}(Z|U)}}{2^{r(R+R_t+R_k+R'+\tilde{R})} \times 2^{-r(1+\epsilon)\mathbb{H}(Z)}} + \frac{2^{-r(1-\epsilon)\mathbb{H}(Z|U)}}{2^{r(R+R_t+R_k+R')} \times 2^{-r(1+\epsilon)\mathbb{H}(Z)}} \\
& \left. + \frac{2^{-r(1-\epsilon)\mathbb{H}(S|U)} \times 2^{-r(1-\epsilon)\mathbb{H}(Z|U,S)}}{2^{r(R+R_t+R_k+R')} \times 2^{-r(1+\epsilon)\mathbb{H}(Z)}} + \frac{2^{r(R_T+R_K)} \times 2^{-r(1-\epsilon)\mathbb{H}(Z)}}{2^{r\tilde{R}} \times 2^{-r(1+\epsilon)\mathbb{H}(Z)}} + 1 \right) \\
& \leq 2|S||V||U||Z|e^{-r\epsilon\mu_{S,V,U,Z}} r \log\left(\frac{4}{\mu_Z} + 1\right). \tag{141}
\end{aligned}$$

In (141) $\mu_{S,V,Z,U} = \min_{(s,v,z,u) \in (S,V,Z,U)} P_{U,S,Z}(u, s, z)$ and $\mu_Z = \min_{z \in Z} P_Z(z)$. When $r \rightarrow \infty$ then $\Psi_2 \rightarrow 0$ and Ψ_1 goes to zero when r grows if

$$R + R_t + R_k + R' + \tilde{R} - R_T - R_K > \mathbb{I}(U, S; Z) - \mathbb{H}(S|U, V), \tag{142}$$

$$\tilde{R} - R_T - R_K > \mathbb{I}(S; Z) - \mathbb{H}(S|V) \tag{143}$$

$$R + R_t + R_k + R' + \tilde{R} - R_T - R_K > \mathbb{I}(U; Z), \tag{144}$$

$$R + R_t + R_k + R' > \mathbb{I}(U; Z), \tag{145}$$

$$R + R_t + R_k + R' > \mathbb{I}(U, S; Z) - \mathbb{H}(S|U), \tag{146}$$

$$\tilde{R} - R_T - R_K > 0 \tag{147}$$

where (144) is redundant because of (145) and (147) and (146) is redundant because of (145).

Decoding and Error Probability Analysis: By following the same steps as in [6], the probability of error for decoding the message vanishes when n grows if

$$R + R_t + R' < \mathbb{I}(U; Y). \quad (148)$$

To bound the probability of error at the encoder and the decoder for key generation we need the following lemma,

Lemma 2 (Typical With High Probability). *If $(R', \tilde{R}) \in \mathbb{R}_+^2$ satisfies (134) to (136), then for any $(m_j, t_{j-1}, k_{j-2}) \in (\mathcal{M}_j, \mathcal{T}_{j-1}, \mathcal{K}_{j-2})$ and $\epsilon > 0$, we have*

$$\mathbb{E}_{\mathcal{C}_n} \mathbb{P}_P \left((U^r(m_j, t_{j-1}, k_{j-2}, L_j), V^r(A_j), S_j^r) \notin \mathcal{T}_\epsilon^{(n)} | \mathcal{C}_n \right) \xrightarrow{r \rightarrow \infty} 0, \quad (149)$$

where P is the induced distribution over the codebook defined in (119).

The proof of Lemma (2) is given in Appendix D.

We now analyze the probability of error at the encoder and the decoder for key generation. Let (A_{j-1}, T_{j-1}) denote the chosen indices at the encoder and \hat{A}_{j-1} be the estimate of the index A_{j-1} at the decoder. At the end of block j , by decoding U_j^r , the receiver has access to T_{j-1} . To find A_{j-1} we define the error event

$$\mathcal{E} = \{(V_{j-1}^r(\hat{A}_{j-1}), S_{j-1}^r, U_{j-1}^r, Y_{j-1}^r) \notin \mathcal{T}_\epsilon^{(n)}\}, \quad (150)$$

and consider the events

$$\mathcal{E}_1 = \{(V_{j-1}^r(a_{j-1}), S_{j-1}^r) \notin \mathcal{T}_\epsilon^{(n)} \text{ for all } a_{j-1} \in \llbracket 1, 2^{r\tilde{R}} \rrbracket\}, \quad (151)$$

$$\mathcal{E}_2 = \{(V_{j-1}^r(A_{j-1}), S_{j-1}^r, U_{j-1}^r, Y_{j-1}^r) \notin \mathcal{T}_\epsilon^{(n)}\}, \quad (152)$$

$$\mathcal{E}_3 = \{(V_{j-1}^r(\tilde{a}_{j-1}), U_{j-1}^r, Y_{j-1}^r) \in \mathcal{T}_\epsilon^{(n)} \text{ for some } a_{j-1} \in \mathcal{B}(T_{j-1}), \tilde{a}_{j-1} \neq A_{j-1}\}. \quad (153)$$

By the union bound we have

$$P(\mathcal{E}) \leq P(\mathcal{E}_1) + P(\mathcal{E}_1^c \cap \mathcal{E}_2) + P(\mathcal{E}_3). \quad (154)$$

According to Lemma 2 the first term on the RHS of (154) vanishes when r grows if we have (134) to (136). Following the steps in [24, Sec. 11.3.1], the last two terms on the right hand side of (154) go to zero when r grows if

$$\tilde{R} > \mathbb{I}(S; V), \quad (155)$$

$$\tilde{R} - R_t > \mathbb{I}(V; U, Y). \quad (156)$$

Input Cost Analysis: The proof follows along lines similar to [6, Sec V].

The region in Theorem 3 is derived by remarking that the scheme requires $R_K + R_T \geq R_k + R_t$ and applying Fourier-Motzkin to (134) to (134) and (142), (143), (145), (147), (148), and (156).

APPENDIX D

PROOF OF LEMMA 2

For a fix $\epsilon > 0$ consider the PMF Γ defined in (116). With respect to the random experiment described by Γ we have

$$\mathbb{E}_{\mathcal{C}_n} \mathbb{P}_\Gamma \left((U^r(m_j, t_{j-1}, k_{j-2}, L_j), V^r(A_j), S_j^r) \notin \mathcal{T}_\epsilon^{(n)} | \mathcal{C}_n \right) \xrightarrow{r \rightarrow \infty} 0, \quad (157)$$

since $U^r(m_j, t_{j-1}, k_{j-2}, L_j) \sim P_U^r$ and $V^r(A_j) \sim P_V^r$ for every $(m_j, t_{j-1}, k_{j-2}) \in (\mathcal{M}_j, \mathcal{T}_{j-1}, \mathcal{K}_{j-2})$ and S_j^r is derived by passing $(U^r(m_j, t_{j-1}, k_{j-2}, L_j), V^r(A_j))$ through the DMC $P_{S|U,V}^{\otimes r}$. Therefore (157) holds by weak law of large numbers. We also have

$$\begin{aligned} & \mathbb{E}_{\mathcal{C}_n} \|P_{U^r, V^r, S_j^r}^{(\mathcal{C}_n)} - \Gamma_{U^r, V^r, S_j^r}^{(\mathcal{C}_n)}\|_1 \\ & \leq \mathbb{E}_{\mathcal{C}_n} \|P_{M_j, T_{j-1}, K_{j-2}, S_j^r, L_j, A_j, U^r, V^r, Z_j^r, K_{j-1}, T_j, K_j}^{(\mathcal{C}_n)} - \Gamma_{M_j, T_{j-1}, K_{j-2}, S_j^r, L_j, A_j, U^r, V^r, Z_j^r, K_{j-1}, T_j, K_j}^{(\mathcal{C}_n)}\|_1 \xrightarrow{r \rightarrow \infty} 0, \end{aligned} \quad (158)$$

where the RHS of (158) vanishes when r grows because of (133).

We now define $g_n : \mathcal{U}^r \times \mathcal{V}^r \times \mathcal{S}_j^r \rightarrow \mathbb{R}$ as $g_n(u^r, v^r, s_j^r) \triangleq \mathbb{1}_{\{(u^r, v^r, s_j^r) \notin \mathcal{T}_\epsilon^{(n)}\}}$. We now have

$$\begin{aligned} & \mathbb{E}_{\mathcal{C}_n} \mathbb{P}_P \left((U^r(m_j, t_{j-1}, k_{j-2}, L_j), V^r(A_j), S_j^r) \notin \mathcal{T}_\epsilon^{(n)} | \mathcal{C}_n \right) \\ & = \mathbb{E}_{\mathcal{C}_n} \mathbb{E}_P \left[g_n(U^r(m_j, t_{j-1}, k_{j-2}, L_j), V^r(A_j), S_j^r) | \mathcal{C}_n \right] \\ & = \mathbb{E}_{\mathcal{C}_n} \mathbb{E}_\Gamma \left[g_n(U^r(m_j, t_{j-1}, k_{j-2}, L_j), V^r(A_j), S_j^r) | \mathcal{C}_n \right] \\ & + \mathbb{E}_{\mathcal{C}_n} \left| \mathbb{E}_P \left[g_n(U^r(m_j, t_{j-1}, k_{j-2}, L_j), V^r(A_j), S_j^r) | \mathcal{C}_n \right] - \mathbb{E}_\Gamma \left[g_n(U^r(m_j, t_{j-1}, k_{j-2}, L_j), V^r(A_j), S_j^r) | \mathcal{C}_n \right] \right| \\ & \stackrel{(a)}{\leq} \mathbb{E}_{\mathcal{C}_n} \mathbb{E}_\Gamma \left[g_n(U^r(m_j, t_{j-1}, k_{j-2}, L_j), V^r(A_j), S_j^r) | \mathcal{C}_n \right] + \mathbb{E}_{\mathcal{C}_n} \|P_{U^r, V^r, S_j^r}^{(\mathcal{C}_n)} - \Gamma_{U^r, V^r, S_j^r}^{(\mathcal{C}_n)}\|_1 \end{aligned} \quad (159)$$

where (a) follows from [26, Property 1] for g_n being bounded by 1. From (157) and (158) the RHS of (159) vanishes when r grows.

APPENDIX E

PROOF OF THEOREM 4

We adopt a block-Markov encoding scheme in which $B-1$ independent messages are transmitted over B channel blocks each of length r , such that $n = rB$. The warden's observation is $Z^n = (Z_1^r, \dots, Z_B^r)$, the target output distribution is $Q_Z^{\otimes n}$, and Equation (63), describing the distance between the two distributions, continues to hold. The random code generation is as follows:

Fix $P_U(u)$, $P_{U|S}(u|s)$, $x(u, s)$, $P_{S,U,X,Y,Z}(s, u, x, y, z) = Q_S(s)P_{U|S}(u|s)\mathbb{1}_{\{x(u,s)=x\}}W_{Y,Z|X,S}$, and $\epsilon_1 > \epsilon_2 > 0$ such that, $Q_Z = Q_0$ and $\mathbb{E}[g(X)] \leq \frac{\epsilon_2}{1+\epsilon_2}$.

Codebook Generation for Keys: For each block $j \in \llbracket 1, B \rrbracket$, to generate a key K_j of rate R_K by using the channel state S_j^r , we use the following lemma

Lemma 3. ([27]) *Let's assume $\epsilon > 0$ is an arbitrarily small number and let*

$$R_t > \mathbb{H}(S|U, Y), \quad (160)$$

then there exist deterministic functions $\sigma : \mathcal{S}^r \rightarrow \llbracket 1, 2^{rR_t} \rrbracket$, which assigns any sequence S^r uniformly at random to an index $T \in \llbracket 1, 2^{rR_t} \rrbracket$, and $\psi : \llbracket 1, 2^{rR_t} \rrbracket \times \mathcal{U}^r \times \mathcal{V}^r \rightarrow \mathcal{S}^r$ such that

$$P\{S_j^r \neq \hat{S}_j^r\} \leq \epsilon, \quad (161)$$

for sufficiently large r , where $\hat{S}_j^r = \psi(\sigma(S_j^r), U_j^r, Y_j^r)$.

Then, we create a function $\Phi : \mathcal{S}_j^r \rightarrow \llbracket 1, 2^{rR_K} \rrbracket$ through random binning by choosing the value of $\Phi(S_j^r)$ independently and uniformly at random for every $S_j^r \in \mathcal{S}^r$. The key $k_j = \Phi(s_j^r)$ obtained in block $j \in \llbracket 1, B \rrbracket$ from the state sequence s_j^r is used to assist the encoder in the block $j+2$.

Codebook Generation for Messages: For each block $j \in \llbracket 1, B \rrbracket$ and for each $m_j \in \llbracket 1, 2^{rR} \rrbracket$, $t_{j-1} \in \llbracket 1, 2^{rR_t} \rrbracket$, $k_{j-2} \in \llbracket 1, 2^{rR_k} \rrbracket$, randomly and independently generate 2^{rR} codewords $u^r(m_j, t_{j-1}, k_{j-2}, \ell_j)$, $\ell_j \in \llbracket 1, 2^{rR'} \rrbracket$, according to $\prod_{i=1}^r p(u_i)$. These constitute the codebook \mathcal{C}_n . The indices $(m_j, t_{j-1}, k_{j-2}, \ell_j)$ can be viewed as a three layer binning. We define an ideal PMF for codebook \mathcal{C}_n , as an approximate distribution to facilitate the analysis

$$\begin{aligned} \Gamma_{M_j, T_{j-1}, K_{j-2}, L_j, U^r, S_j^r, Z_j^r, K_{j-1}, T_j, K_j}^{(\mathcal{C}_n)}(m_j, t_{j-1}, k_{j-2}, \ell_j, \tilde{u}^r, s_j^r, z_j^r, k_{j-1}, t_j, k_j) \\ = 2^{-r(R+R_t+R_k+R')} \times \mathbb{1}_{\{u^r(m_j, t_{j-1}, k_{j-2}, \ell_j) = \tilde{u}^r\}} \times P_{S|U}^{\otimes r}(s_j^r | \tilde{u}^r) \\ \times W_{Z|U, S}^{\otimes r}(z_j^r | \tilde{u}^r, s_j^r) \times 2^{-rR_k} \times \mathbb{1}_{\{\sigma(s_j^r) = t_j\}} \times \mathbb{1}_{\{\Phi(s_j^r) = k_j\}}, \end{aligned} \quad (162)$$

where $W_{Z|U, S}$ is the marginal distribution of $W_{Y, Z|U, S}$ defined in Theorem 4.

Encoding: In the first block, the encoder chooses the indices (m_1, t_0, k_{-1}) uniformly at random and then chooses the index ℓ_1 according to distribution with $j = 1$,

$$f(\ell_j | s_j^r, m_j, t_{j-1}, k_{j-2}) = \frac{P_{S|U}^{\otimes r}(s_j^r | u^r(m_j, t_{j-1}, k_{j-2}, \ell_j))}{\sum_{\ell_j' \in \llbracket 1, 2^{rR'} \rrbracket} P_{S|U, V}^{\otimes r}(s_j^r | u^r(m_j, t_{j-1}, k_{j-2}, \ell_j'))}, \quad (163)$$

where $P_{S|U}^{\otimes r}$ is defined from the ideal PMF in (162). Based on these indices, the encoder computes $u^r(m_1, t_0, k_{-1}, \ell_1)$ and transmits codeword x^r , where $x_i = x(u_i(m_1, t_0, k_{-1}, \ell_1), s_i)$. Simultaneously, it uses its CSI to generate reconciliation index t_1 and key k_1 to be used in the second and the third block, respectively.

In the second block, the encoder chooses the indices (m_2, k_0) uniformly at random and, using t_1 from the previous block, chooses the indices ℓ_2 according to the likelihood encoder described in (163) with $j = 2$. Based on these indices the encoder computes $u^r(m_2, t_1, k_0, \ell_2)$, and transmits codeword x^r , where $x_i = x(u_i(m_2, t_1, k_0, \ell_2), s_i)$. Simultaneously, it uses its CSI to generate reconciliation index t_2 and key k_2 to be used in the third and the fourth block, respectively.

In block $j \in \llbracket 3, B \rrbracket$, to send the message m_j and reconciliation index t_{j-1} , generated in the previous block, according to the generated key k_{j-2} from the the block $j - 2$ and the CSI of the current block, the encoder selects index ℓ_j from bin (m_j, t_{j-1}, k_{j-2}) according to the likelihood encoder described in (163). The encoder then transmits codeword x^r , where each coordinate of the transmitted signal is a function of the state, as well as the corresponding sample of the transmitter's codeword u_i , i.e., $x_i = x(u_i(m_j, t_{j-1}, k_{j-2}, \ell_j), s_i)$. Simultaneously, the encoder uses its CSI s_j^r to generate a reconciliation index t_j and a key k_j to be used in the block $j + 1$ and the block $j + 2$, respectively.

Define

$$\begin{aligned} \Upsilon_{M_j, T_{j-1}, K_{j-2}, S_j^r, L_j, U^r, Z_j^r, K_{j-1}, T_j, K_j}^{(\mathcal{C}_n)}(m_j, t_{j-1}, k_{j-2}, s_j^r, \ell_j, \tilde{u}^r, z_j^r, k_{j-1}, t_j, k_j) \\ \triangleq 2^{-r(R+R_t+R_k)} \times Q_S^{\otimes r}(s_j^r) \times f(\ell_j | s_j^r, m_j, t_{j-1}, k_{j-2}) \times \mathbb{1}_{\{u^r(m_j, t_{j-1}, k_{j-2}, \ell_j) = \tilde{u}^r\}} \\ \times W_{Z|U, S}^{\otimes r}(z_j^r | \tilde{u}^r, s_j^r) \times 2^{-rR_k} \times \mathbb{1}_{\{\sigma(s_j^r) = t_j\}} \times \mathbb{1}_{\{\Phi(s_j^r) = k_j\}}. \end{aligned} \quad (164)$$

For a fixed codebook \mathcal{C}_n , the induced joint distribution over the codebook (i.e. $P^{(\mathcal{C}_n)}$) satisfies

$$\|P_{M_j, T_{j-1}, K_{j-2}, S_j^r, L_j, U^r, Z_j^r, K_{j-1}, T_j, K_j}^{(\mathcal{C}_n)} - \Upsilon_{M_j, T_{j-1}, K_{j-2}, S_j^r, L_j, U^r, Z_j^r, K_{j-1}, T_j, K_j}^{(\mathcal{C}_n)}\|_1 \leq \epsilon. \quad (165)$$

This intermediate distribution $\Upsilon^{(\mathcal{C}_n)}$ approximates the true distribution $P^{(\mathcal{C}_n)}$ and will be used in the sequel for bounding purposes. Expression (165) holds because the main difference in $\Upsilon^{(\mathcal{C}_n)}$ is assuming the keys K_{j-2}, K_{j-1}

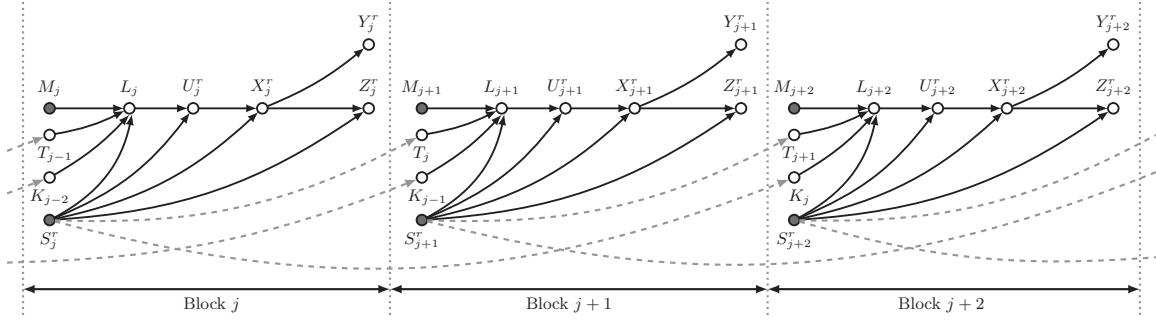

Fig. 9. Functional dependence graph for the block-Markov encoding scheme

and the reconciliation index T_{j-1} are uniformly distributed, which is made (arbitrarily) nearly uniform in $P^{(C_n)}$ with appropriate control of rate.

Covert Analysis: We now show that this coding scheme guarantees that $\mathbb{E}_{C_n}[\mathbb{D}(P_{Z^n}^{(C_n)} \| Q_Z^{\otimes n})] \xrightarrow{n \rightarrow \infty} 0$. Similar to (123) by using the functional dependence graph depicted in Fig. 9 it follows that

$$\mathbb{D}(P_{Z^n}^{(C_n)} \| Q_Z^{\otimes n}) \leq 2 \sum_{j=1}^B \mathbb{D}(P_{Z_j^r, K_{j-1}, K_j, T_j}^{(C_n)} \| Q_Z^{\otimes r} Q_{K_{j-1}} Q_{K_j} Q_{T_j}). \quad (166)$$

Using the triangle inequality

$$\begin{aligned} & \mathbb{E}_{C_n} \| P_{Z_j^r, K_{j-1}, K_j, T_j}^{(C_n)} - Q_Z^{\otimes r} Q_{K_{j-1}} Q_{K_j} Q_{T_j} \|_1 \leq \\ & \mathbb{E}_{C_n} \| P_{Z_j^r, K_{j-1}, K_j, T_j}^{(C_n)} - \Gamma_{Z_j^r, K_{j-1}, K_j, T_j}^{(C_n)} \|_1 + \mathbb{E}_{C_n} \| \Gamma_{Z_j^r, K_{j-1}, K_j, T_j}^{(C_n)} - Q_Z^{\otimes r} Q_{K_{j-1}} Q_{K_j} Q_{T_j} \|_1 \\ & \leq \mathbb{E}_{C_n} \| P_{Z_j^r, K_{j-1}, K_j, T_j}^{(C_n)} - \Upsilon_{Z_j^r, K_{j-1}, K_j, T_j}^{(C_n)} \|_1 + \mathbb{E}_{C_n} \| \Upsilon_{Z_j^r, K_{j-1}, K_j, T_j}^{(C_n)} - \Gamma_{Z_j^r, K_{j-1}, K_j, T_j}^{(C_n)} \|_1 \\ & \quad + \mathbb{E}_{C_n} \| \Gamma_{Z_j^r, K_{j-1}, K_j, T_j}^{(C_n)} - Q_Z^{\otimes r} Q_{K_{j-1}} Q_{K_j} Q_{T_j} \|_1. \end{aligned} \quad (167)$$

From (165) the first term on the RHS of (167) goes to zero when n grows. To bound the second term on the RHS of (167)

$$\Gamma_{M_j, T_{j-1}, K_{j-2}}^{(C_n)} = 2^{-r(R+R_t+R_k)} = \Upsilon_{M_j, T_{j-1}, K_{j-2}}^{(C_n)}, \quad (168)$$

$$\Gamma_{L_j | M_j, T_{j-1}, K_{j-2}, S_j^r}^{(C_n)} = f(\ell_j | s_j^r, m_j, t_{j-1}, k_{j-2}) = \Upsilon_{L_j | M_j, T_{j-1}, K_{j-2}, S_j^r}^{(C_n)}, \quad (169)$$

$$\Gamma_{U^r | M_j, T_{j-1}, K_{j-2}, S_j^r, L_j}^{(C_n)} = \mathbb{1}_{\{u^r(m_j, t_{j-1}, k_{j-2}, \ell_j) = \bar{u}^r\}} = \Upsilon_{U^r | M_j, T_{j-1}, K_{j-2}, S_j^r, L_j}^{(C_n)}, \quad (170)$$

$$\Gamma_{Z_j^r | M_j, T_{j-1}, K_{j-2}, S_j^r, L_j, U^r}^{(C_n)} = W_{Z|U, S}^{\otimes r} = \Upsilon_{Z_j^r | M_j, T_{j-1}, K_{j-2}, S_j^r, L_j, U^r}^{(C_n)}, \quad (171)$$

$$\Gamma_{K_{j-1} | M_j, T_{j-1}, K_{j-2}, S_j^r, L_j, U^r, Z_j^r}^{(C_n)} = 2^{-rR_k} = \Upsilon_{K_{j-1} | M_j, T_{j-1}, K_{j-2}, S_j^r, L_j, U^r, Z_j^r}^{(C_n)}, \quad (172)$$

$$\Gamma_{T_j | M_j, T_{j-1}, K_{j-2}, S_j^r, L_j, U^r, Z_j^r, K_{j-1}}^{(C_n)} = \mathbb{1}_{\{\sigma(s_j^r) = t_j\}} = \Upsilon_{T_j | M_j, T_{j-1}, K_{j-2}, S_j^r, L_j, U^r, Z_j^r, K_{j-1}}^{(C_n)}, \quad (173)$$

$$\Gamma_{K_j | M_j, T_{j-1}, K_{j-2}, S_j^r, L_j, U^r, Z_j^r, K_{j-1}, T_j}^{(C_n)} = \mathbb{1}_{\{\Phi(s_j^r) = k_j\}} = \Upsilon_{K_j | M_j, T_{j-1}, K_{j-2}, S_j^r, L_j, U^r, Z_j^r, K_{j-1}, T_j}^{(C_n)}, \quad (174)$$

where (169) follows from (163). Hence,

$$\begin{aligned} & \mathbb{E}_{C_n} \| \Upsilon_{Z_j^r, K_{j-1}, T_j, K_j}^{(C_n)} - \Gamma_{Z_j^r, K_{j-1}, T_j, K_j}^{(C_n)} \|_1 \\ & \leq \mathbb{E}_{C_n} \| \Upsilon_{M_j, T_{j-1}, K_{j-2}, S_j^r, L_j, U^r, Z_j^r, K_{j-1}, T_j, K_j}^{(C_n)} - \Gamma_{M_j, T_{j-1}, K_{j-2}, S_j^r, L_j, U^r, Z_j^r, K_{j-1}, T_j, K_j}^{(C_n)} \|_1 \\ & \stackrel{(a)}{=} \mathbb{E}_{C_n} \| \Upsilon_{M_j, T_{j-1}, K_{j-2}, S_j^r}^{(C_n)} - \Gamma_{M_j, T_{j-1}, K_{j-2}, S_j^r}^{(C_n)} \|_1 \\ & \stackrel{(b)}{=} \mathbb{E}_{C_n} \| Q_S^{\otimes r} - \Gamma_{S_j^r | M_j=1, T_{j-1}=1, K_{j-2}=1}^{(C_n)} \|_1, \end{aligned} \quad (175)$$

where (a) follows from (169)-(174) and (b) follows from the symmetry of the codebook construction with respect to M_j , T_{j-1} , and K_{j-2} and (168). Based on the soft covering lemma [28, Corollary VII.5] the RHS of (175) vanishes if

$$R' > \mathbb{I}(U; S). \quad (176)$$

We now proceed to bound the third term on the RHS of (167). First, consider the marginal

$$\begin{aligned} \Gamma_{Z_j^r, K_{j-1}, K_j, T_j}^{(C_n)}(z_j^r, k_{j-1}, k_j, t_j) &= \sum_{m_j} \sum_{t_{j-1}} \sum_{k_{j-2}} \sum_{\ell_j} \sum_{s_j^r} \frac{1}{2^{r(R+R_t+2R_k+R')}} \\ &\times P_{S|U}^{\otimes r}(s_j^r | u^r(m_j, t_{j-1}, k_{j-2}, \ell_j)) \times W_{Z|U,S}^{\otimes r}(z_j^r | u^r(m_j, t_{j-1}, k_{j-2}, \ell_j), s_j^r) \\ &\times \mathbb{1}_{\{\sigma(s_j^r)=t_j\}} \times \mathbb{1}_{\{\Phi(s_j^r)=k_j\}}. \end{aligned} \quad (177)$$

Using Pinsker's inequality, it is sufficient to bound $\mathbb{E}_{C_n} [\mathbb{D}(\Gamma_{Z_j^r, K_{j-1}, K_j, T_j}^{(C_n)} \| Q_Z^{\otimes r} Q_{K_{j-1}} Q_{K_j} Q_{T_j})]$ as follows

$$\begin{aligned} &\mathbb{E}_{C_n} [\mathbb{D}(\Gamma_{Z_j^r, K_{j-1}, K_j, T_j}^{(C_n)} \| Q_Z^{\otimes r} Q_{K_{j-1}} Q_{K_j} Q_{T_j})] \\ &= \mathbb{E}_{C_n} \left[\sum_{(z_j^r, k_{j-1}, k_j, t_j)} \Gamma^{(C_n)}(z_j^r, k_{j-1}, k_j, t_j) \log \left(\frac{\Gamma^{(C_n)}(z_j^r, k_{j-1}, k_j, t_j)}{Q_Z^{\otimes r}(z_j^r) Q_{K_{j-1}}(k_{j-1}) Q_{K_j}(k_j) Q_{T_j}(t_j)} \right) \right] \\ &= \mathbb{E}_{C_n} \left[\sum_{(z_j^r, k_{j-1}, k_j, t_j)} \sum_{m_j} \sum_{t_{j-1}} \sum_{k_{j-2}} \sum_{\ell_j} \sum_{s_j^r} \frac{1}{2^{r(R+R_t+2R_k+R')}} \right. \\ &\times P_{S|U}^{\otimes r}(s_j^r | u^r(m_j, t_{j-1}, k_{j-2}, \ell_j)) \times W_{Z|U,S}^{\otimes r}(z_j^r | u^r(m_j, t_{j-1}, k_{j-2}, \ell_j), s_j^r) \times \mathbb{1}_{\{\sigma(s_j^r)=t_j\}} \times \mathbb{1}_{\{\Phi(s_j^r)=k_j\}} \\ &\times \log \left(\frac{1}{2^{r(R+R_t+R_k+R'-R_T-R_K)} Q_Z^{\otimes r}(z_j^r)} \right) \\ &\times \sum_{\tilde{m}_j} \sum_{\tilde{t}_{j-1}} \sum_{\tilde{k}_{j-2}} \sum_{\tilde{\ell}_j} \sum_{\tilde{s}_j^r} P_{S|U}^{\otimes r}(\tilde{s}_j^r | u^r(\tilde{m}_j, \tilde{t}_{j-1}, \tilde{k}_{j-2}, \tilde{\ell}_j)) \times W_{Z|U,S}^{\otimes r}(z_j^r | u^r(\tilde{m}_j, \tilde{t}_{j-1}, \tilde{k}_{j-2}, \tilde{\ell}_j), \tilde{s}_j^r) \\ &\left. \times \mathbb{1}_{\{\sigma(\tilde{s}_j^r)=t_j\}} \times \mathbb{1}_{\{\Phi(\tilde{s}_j^r)=k_j\}} \right) \\ &\stackrel{(a)}{\leq} \sum_{(z_j^r, k_{j-1}, k_j, t_j)} \sum_{m_j} \sum_{t_{j-1}} \sum_{k_{j-2}} \sum_{\ell_j} \frac{1}{2^{r(R+R_t+2R_k+R')}} \sum_{s_j^r} \sum_{u^r} \Gamma_{U^r, S^r, Z^r}^{(C_n)}(u^r(m_j, t_{j-1}, k_{j-2}, \ell_j), s_j^r, z_j^r) \\ &\times \mathbb{E}_{\sigma(s_j^r)} [\mathbb{1}_{\{\sigma(s_j^r)=t_j\}}] \times \mathbb{E}_{\Phi(s_j^r)} [\mathbb{1}_{\{\Phi(s_j^r)=k_j\}}] \\ &\times \log \mathbb{E}_{\substack{(m_j, t_{j-1}, k_{j-2}, \ell_j), \\ (\sigma(s_j^r), \Phi(s_j^r))}} \left(\frac{1}{2^{r(R+R_t+R_k+R'-R_T-R_K)} Q_Z^{\otimes r}(z_j^r)} \right) \\ &\times \sum_{\tilde{m}_j} \sum_{\tilde{t}_{j-1}} \sum_{\tilde{k}_{j-2}} \sum_{\tilde{\ell}_j} \sum_{\tilde{s}_j^r} P_{S|U}^{\otimes r}(\tilde{s}_j^r | u^r(\tilde{m}_j, \tilde{t}_{j-1}, \tilde{k}_{j-2}, \tilde{\ell}_j)) \times W_{Z|U,S}^{\otimes r}(z_j^r | u^r(\tilde{m}_j, \tilde{t}_{j-1}, \tilde{k}_{j-2}, \tilde{\ell}_j), \tilde{s}_j^r) \\ &\times \mathbb{1}_{\{\sigma(\tilde{s}_j^r)=t_j\}} \times \mathbb{1}_{\{\Phi(\tilde{s}_j^r)=k_j\}} \Big) \\ &\stackrel{(b)}{\leq} \sum_{(z_j^r, k_{j-1}, k_j, t_j)} \sum_{m_j} \sum_{t_{j-1}} \sum_{k_{j-2}} \sum_{\ell_j} \frac{1}{2^{r(R+R_t+2R_k+R')}} \sum_{s_j^r} \sum_{u^r} \Gamma_{U^r, S^r, Z^r}^{(C_n)}(u^r(m_j, t_{j-1}, k_{j-2}, \ell_j), s_j^r, z_j^r) \\ &\times \frac{1}{2^{rR_T}} \times \frac{1}{2^{rR_K}} \times \log \left(\frac{P_{S|U}^{\otimes r}(s_j^r | u^r(m_j, t_{j-1}, k_{j-2}, \ell_j)) \times W_{Z|U,S}^{\otimes r}(z_j^r | u^r(m_j, t_{j-1}, k_{j-2}, \ell_j), s_j^r)}{2^{r(R+R_t+R_k+R'-R_T-R_K)} Q_Z^{\otimes r}(z_j^r)} \right) \end{aligned}$$

$$\begin{aligned}
& + \mathbb{E}_{\setminus(m_j, t_{j-1}, k_{j-2}, \ell_j)} \left[\frac{1}{2^{r(R+R_t+R_k+R'-R_T-R_K)} Q_Z^{\otimes r}(z_j^r)} \right. \\
& \times \sum_{(\tilde{m}_j, \tilde{t}_{j-1}, \tilde{k}_{j-2}, \tilde{\ell}_j) \neq (m_j, t_{j-1}, k_{j-2}, \ell_j)} P_{S|U}^{\otimes r}(s_j^r | u^r(\tilde{m}_j, \tilde{t}_{j-1}, \tilde{k}_{j-2}, \tilde{\ell}_j)) \times W_{Z|U,S}^{\otimes r}(z_j^r | u^r(\tilde{m}_j, \tilde{t}_{j-1}, \tilde{k}_{j-2}, \tilde{\ell}_j), s_j^r) \left. \right] \\
& + \mathbb{E}_{\setminus(\sigma(s_j^r), \Phi(s_j^r))} \left[\frac{1}{2^{r(R+R_t+R_k+R'-R_T-R_K)} Q_Z^{\otimes r}(z_j^r)} \right. \\
& \times \sum_{\tilde{s}_j^r \neq s_j^r} P_{S|U}^{\otimes r}(\tilde{s}_j^r | u^r(m_j, t_{j-1}, k_{j-2}, \ell_j)) \times W_{Z|U,S}^{\otimes r}(z_j^r | u^r(m_j, t_{j-1}, k_{j-2}, \ell_j), \tilde{s}_j^r) \times \mathbb{1}_{\{\sigma(\tilde{s}_j^r)=t_j\}} \times \mathbb{1}_{\{\Phi(\tilde{s}_j^r)=k_j\}} \left. + 1 \right) \\
& \stackrel{(c)}{\leq} \sum_{(z_j^r, k_{j-1}, k_j, t_j)} \sum_{m_j} \sum_{t_{j-1}} \sum_{k_{j-2}} \sum_{\ell_j} \frac{1}{2^{r(R+R_t+2R_k+R'+R_T+R_K)}} \sum_{s_j^r} \sum_{u^r} \Gamma_{U^r, S^r, Z^r}^{(C_n)}(u^r(m_j, t_{j-1}, k_{j-2}, \ell_j), s_j^r, z_j^r) \\
& \times \log \left(\frac{P_{S|U}^{\otimes r}(s_j^r | u^r(m_j, t_{j-1}, k_{j-2}, \ell_j)) \times W_{Z|U,S}^{\otimes r}(z_j^r | u^r(m_j, t_{j-1}, k_{j-2}, \ell_j), s_j^r)}{2^{r(R+R_t+R_k+R'-R_T-R_K)} Q_Z^{\otimes r}(z_j^r)} \right. \\
& + \sum_{(\tilde{m}_j, \tilde{t}_{j-1}, \tilde{k}_{j-2}, \tilde{\ell}_j) \neq (m_j, t_{j-1}, k_{j-2}, \ell_j)} \frac{Q_S^{\otimes r}(s_j^r) \times W_{Z|S}^{\otimes r}(z_j^r | s_j^r)}{2^{r(R+R_t+R_k+R'+R_T-R_K)} Q_Z^{\otimes r}(z_j^r)} \\
& \left. + \sum_{\tilde{s}_j^r \neq s_j^r} \frac{P_{S|U}^{\otimes r}(\tilde{s}_j^r | u^r(m_j, t_{j-1}, k_{j-2}, \ell_j)) \times W_{Z|U,S}^{\otimes r}(z_j^r | u^r(m_j, t_{j-1}, k_{j-2}, \ell_j), \tilde{s}_j^r)}{2^{r(R+R_t+R_k+R')} Q_Z^{\otimes r}(z_j^r)} + 1 \right) \\
& \triangleq \Psi_1 + \Psi_2, \tag{178}
\end{aligned}$$

where (a) follows from Jensen's inequality, (b) and (c) hold because $\mathbb{1}_{\{\Phi(v_j^r)=k_j\}} \leq 1$. We defined Ψ_1 and Ψ_2 as

$$\begin{aligned}
\Psi_1 & = \sum_{(k_{j-1}, k_j, t_j)} \sum_{m_j} \sum_{t_{j-1}} \sum_{k_{j-2}} \sum_{\ell_j} \frac{1}{2^{r(R+R_t+2R_k+R'+R_T+R_K)}} \\
& \quad \sum_{(z_j^r, s_j^r, u^r(m_j, t_{j-1}, k_{j-2}, \ell_j)) \in T_\epsilon^{(n)}} \Gamma_{Z^r, S^r, U^r}^{(C_n)}(z_j^r, s_j^r, u^r(m_j, t_{j-1}, k_{j-2}, \ell_j)) \\
& \quad \times \log \left(\frac{P_{S|U}^{\otimes r}(s_j^r | u^r(m_j, t_{j-1}, k_{j-2}, \ell_j)) \times W_{Z|U,S}^{\otimes r}(z_j^r | u^r(m_j, t_{j-1}, k_{j-2}, \ell_j), s_j^r)}{2^{r(R+R_t+R_k+R'-R_T-R_K)} Q_Z^{\otimes r}(z_j^r)} \right. \\
& \quad + \sum_{(\tilde{m}_j, \tilde{t}_{j-1}, \tilde{k}_{j-2}, \tilde{\ell}_j) \neq (m_j, t_{j-1}, k_{j-2}, \ell_j)} \frac{Q_S^{\otimes r}(s_j^r) \times W_{Z|S}^{\otimes r}(z_j^r | s_j^r)}{2^{r(R+R_t+R_k+R'+R_T-R_K)} Q_Z^{\otimes r}(z_j^r)} \\
& \quad \left. + \sum_{\tilde{s}_j^r \neq s_j^r} \frac{P_{S|U}^{\otimes r}(\tilde{s}_j^r | u^r(m_j, t_{j-1}, k_{j-2}, \ell_j)) \times W_{Z|U,S}^{\otimes r}(z_j^r | u^r(m_j, t_{j-1}, k_{j-2}, \ell_j), \tilde{s}_j^r)}{2^{r(R+R_t+R_k+R')} Q_Z^{\otimes r}(z_j^r)} + 1 \right) \\
& \leq \sum_{(k_{j-1}, k_j, t_j)} \sum_{m_j} \sum_{t_{j-1}} \sum_{k_{j-2}} \sum_{\ell_j} \frac{1}{2^{r(R+R_t+2R_k+R'+R_T+R_K)}} \\
& \quad \sum_{(z_j^r, s_j^r, u^r(m_j, t_{j-1}, k_{j-2}, \ell_j)) \in T_\epsilon^{(n)}} \Gamma_{Z^r, S^r, U^r}^{(C_n)}(z_j^r, s_j^r, u^r(m_j, t_{j-1}, k_{j-2}, \ell_j)) \\
& \quad \times \log \left(\frac{P_{S|U}^{\otimes r}(s_j^r | u^r(m_j, t_{j-1}, k_{j-2}, \ell_j)) \times W_{Z|U,S}^{\otimes r}(z_j^r | u^r(m_j, t_{j-1}, k_{j-2}, \ell_j), s_j^r)}{2^{r(R+R_t+R_k+R'-R_T-R_K)} Q_Z^{\otimes r}(z_j^r)} \right. \\
& \quad \left. + \frac{2^{r(R_T+R_K)} \times Q_S^{\otimes r}(s_j^r) \times W_{Z|S}^{\otimes r}(z_j^r | s_j^r)}{Q_Z^{\otimes r}(z_j^r)} + \frac{W_{Z|U}^{\otimes r}(z_j^r | u^r(m_j, t_{j-1}, k_{j-2}, \ell_j))}{2^{r(R+R_t+R_k+R')} Q_Z^{\otimes r}(z_j^r)} + 1 \right)
\end{aligned}$$

$$\begin{aligned}
&\leq \log \left(\frac{2^{r(R_T+R_K)} 2^{-r(1-\epsilon)\mathbb{H}(S|U)} 2^{-r(1-\epsilon)\mathbb{H}(Z|U,S)}}{2^{r(R+R_t+R_k+R')} 2^{-r(1+\epsilon)\mathbb{H}(Z)}} + \frac{2^{r(R_T+R_K)} 2^{-r(1-\epsilon)\mathbb{H}(S)} 2^{-r(1-\epsilon)\mathbb{H}(Z|S)}}{2^{-r(1+\epsilon)\mathbb{H}(Z)}} \right. \\
&\quad \left. + \frac{2^{-r(1-\epsilon)\mathbb{H}(Z|U)}}{2^{r(R+R_t+R_k+R')} 2^{-r(1+\epsilon)\mathbb{H}(Z)}} + 1 \right) \tag{179} \\
\Psi_2 &= \sum_{(k_{j-1}, k_j, t_j)} \sum_{m_j} \sum_{t_{j-1}} \sum_{k_{j-2}} \sum_{\ell_j} \frac{1}{2^{r(R+R_t+2R_k+R'+R_T+R_K)}} \\
&\quad \sum_{(z_j^r, s_j^r, u^r(m_j, t_{j-1}, k_{j-2}, \ell_j)) \notin T_\epsilon^{(n)}} \Gamma_{Z^r, S^r, U^r}^{(C_n)}(z_j^r, s_j^r, u^r(m_j, t_{j-1}, k_{j-2}, \ell_j)) \\
&\quad \times \log \left(\frac{P_{S|U}^{\otimes r}(s_j^r | u^r(m_j, t_{j-1}, k_{j-2}, \ell_j)) \times W_{Z|U,S}^{\otimes r}(z_j^r | u^r(m_j, t_{j-1}, k_{j-2}, \ell_j), s_j^r)}{2^{r(R+R_t+R_k+R'-R_T-R_K)} Q_Z^{\otimes r}(z_j^r)} \right. \\
&\quad + \sum_{(\tilde{m}_j, \tilde{t}_{j-1}, \tilde{k}_{j-2}, \tilde{\ell}_j) \neq (m_j, t_{j-1}, k_{j-2}, \ell_j)} \frac{Q_S^{\otimes r}(s_j^r) \times W_{Z|S}^{\otimes r}(z_j^r | s_j^r)}{2^{r(R+R_t+R_k+R'-R_T-R_K)} Q_Z^{\otimes r}(z_j^r)} \\
&\quad \left. + \sum_{\tilde{s}_j^r \neq s_j^r} \frac{P_{S|U}^{\otimes r}(\tilde{s}_j^r | u^r(m_j, t_{j-1}, k_{j-2}, \ell_j)) \times W_{Z|U,S}^{\otimes r}(z_j^r | u^r(m_j, t_{j-1}, k_{j-2}, \ell_j), \tilde{s}_j^r)}{2^{r(R+R_t+R_k+R')} Q_Z^{\otimes r}(z_j^r)} + 1 \right) \\
&\leq \sum_{(k_{j-1}, k_j, t_j)} \sum_{m_j} \sum_{t_{j-1}} \sum_{k_{j-2}} \sum_{\ell_j} \frac{1}{2^{r(R+R_t+2R_k+R'+R_T+R_K)}} \\
&\quad \sum_{(z_j^r, s_j^r, u^r(m_j, t_{j-1}, k_{j-2}, \ell_j)) \notin T_\epsilon^{(n)}} \Gamma_{Z^r, S^r, U^r}^{(C_n)}(z_j^r, s_j^r, u^r(m_j, t_{j-1}, k_{j-2}, \ell_j)) \\
&\quad \times \log \left(\frac{P_{S|U}^{\otimes r}(s_j^r | u^r(m_j, t_{j-1}, k_{j-2}, \ell_j)) \times W_{Z|U,S}^{\otimes r}(z_j^r | u^r(m_j, t_{j-1}, k_{j-2}, \ell_j), s_j^r)}{2^{r(R+R_t+R_k+R'-R_T-R_K)} Q_Z^{\otimes r}(z_j^r)} \right. \\
&\quad \left. + \frac{2^{r(R_T+R_K)} \times Q_S^{\otimes r}(s_j^r) \times W_{Z|S}^{\otimes r}(z_j^r | s_j^r)}{Q_Z^{\otimes r}(z_j^r)} + \frac{W_{Z|U}^{\otimes r}(z_j^r | u^r(m_j, t_{j-1}, k_{j-2}, \ell_j))}{2^{r(R+R_t+R_k+R')} Q_Z^{\otimes r}(z_j^r)} + 1 \right) \\
&\leq 2|S||Z||U|e^{-r\epsilon\mu_{S,Z,U}} r \log\left(\frac{4}{\mu_Z} + 1\right). \tag{180}
\end{aligned}$$

In (180) $\mu_{S,Z,U} = \min_{(s,z,u) \in (S,Z,U)} P_{U,S,Z}(u, s, z)$ and $\mu_Z = \min_{z \in Z} P_Z(z)$. When $r \rightarrow \infty$ then $\Psi_2 \rightarrow 0$ and if we choose $R_T + R_K = \mathbb{H}(S|Z) - \epsilon$, Ψ_1 goes to zero when r grows if

$$R + R_t + R_k + R' > \mathbb{I}(U; S, Z), \tag{181}$$

$$R + R_t + R_k + R' > \mathbb{I}(U; Z) \tag{182}$$

where (182) is redundant because of (181).

Decoding and Error Probability Analysis: By following the same steps as in [6], the probability of error vanishes when n grows if

$$R + R_t + R' < \mathbb{I}(U; Y). \tag{183}$$

Input Cost Analysis: The proof follows similar lines to [6, Sec V].

The region in Theorem 4 is derived by remarking that the scheme requires $R_t + R_k \leq R_T + R_K = \mathbb{H}(S|Z) - \epsilon$ and applying Fourier-Motzkin to (160), (176), (181), and (183).

APPENDIX F
PROOF OF THEOREM 6

We adopt a block-Markov encoding scheme in which $B - 1$ independent messages are transmitted over B channel blocks each of length r , such that $n = rB$. The warden's observation is $Z^n = (Z_1^r, \dots, Z_B^r)$, the target output distribution is $Q_Z^{\otimes n}$, and Equation (63), describing the distance between the two distributions, continues to hold. The random code generation is as follows:

Fix $P_{V|S}(v|s)$, $P_U(u)$, $x(u, s)$, $P_{S,V,U,X,Y,Z}(s, v, u, x, y, z) = Q_S(s)P_{V|S}(v|s)P_U(u)\mathbb{1}_{\{x(u,s)=x\}}W_{Y|Z|X,S}$, and $\epsilon_1 > \epsilon_2 > 0$ such that, $Q_Z = Q_0$ and $\mathbb{E}[g(X)] \leq \frac{\epsilon_2}{1+\epsilon_2}$.

Codebook Generation for Keys: Let $P_V(v) = \sum_s Q_S(s)P_{V|S}(v|s)$. For each block $j \in \llbracket 1, B \rrbracket$, randomly and independently generate $2^{r\tilde{R}}$ sequences $v^r(\ell_j), \ell_j \in \llbracket 1, 2^{r\tilde{R}} \rrbracket$, each according to $\prod_{i=1}^r P_V(v_i)$. Partition the set of indices $\ell_j \in \llbracket 1, 2^{r\tilde{R}} \rrbracket$ into bins $\mathcal{B}(t)$, $t \in \llbracket 1, 2^{rR_k} \rrbracket$ by using function $\varphi : V^r(\ell_j) \rightarrow \llbracket 1, 2^{rR_k} \rrbracket$ through random binning by choosing the value of $\varphi(V^r(\ell_j))$ independently and uniformly at random for every $V^r(\ell_j) \in \mathcal{V}^r$.

For each block $j \in \llbracket 1, B \rrbracket$, create a function $\Phi : V^r(\ell_j) \rightarrow \llbracket 1, 2^{rR_k} \rrbracket$ through random binning by choosing the value of $\Phi(V^r(\ell_j))$ independently and uniformly at random for every $V^r(\ell_j) \in \mathcal{V}^r$. The key $k_j = \Phi(V^r(\ell_j))$ obtained in block $j \in \llbracket 1, B \rrbracket$ from the description of the channel state sequence $V^r(\ell_j)$ is used to assist the encoder in block $j + 2$.

Codebook Generation for Messages: For each block $j \in \llbracket 1, B \rrbracket$ and for each $m_j \in \llbracket 1, 2^{rR} \rrbracket$, $t_{j-1} \in \llbracket 1, 2^{r\tilde{R}} \rrbracket$, and $k_{j-2} \in \llbracket 1, 2^{rR_k} \rrbracket$, randomly and independently generate a sequence $u^r(m_j, t_{j-1}, k_{j-2})$ according to $\prod_{i=1}^r p(u_i)$. These constitute the codebook \mathcal{C}_n . The indices (m_j, t_{j-1}, k_{j-2}) can be viewed as a two layer binning. We define an ideal PMF for codebook \mathcal{C}_n , as an approximate distribution to facilitate the analysis

$$\begin{aligned} \Gamma_{M_j, T_{j-1}, K_{j-2}, L_j, U^r, V_j^r, S_j^r, Z_j^r, K_{j-1}, K_j, T_j}(m_j, t_{j-1}, k_{j-2}, \ell_j, \tilde{u}^r, \tilde{v}^r, s_j^r, z_j^r, k_{j-1}, k_j, t_j) = \\ 2^{-r(R+R_t+R_k+\tilde{R})} \times \mathbb{1}_{\{u^r(m_j, t_{j-1}, k_{j-2}) = \tilde{u}^r\}} \times \mathbb{1}_{\{v^r(\ell_j) = \tilde{v}^r\}} \times P_{S|V}^{\otimes r}(s_j^r | \tilde{v}^r) \times W_{Z|U,S}^{\otimes r}(z_j^r | \tilde{u}^r, s_j^r) \\ \times 2^{-rR_k} \times \mathbb{1}_{\{\varphi(\tilde{v}^r) = t_j\}} \times \mathbb{1}_{\{\Phi(\tilde{v}^r) = k_j\}}, \end{aligned} \quad (184)$$

where $W_{Z|U,S}$ is the marginal distribution of $W_{Y,Z|U,S}$ defined in Theorem (3).

Encoding: In the first block, the Encoder chooses the indices (m_1, t_0, k_{-1}) uniformly at random and then, based on these indices computes $u^r(m_1, t_0, k_{-1})$ and transmits a codeword x^r , where $x_i = x(u_i(m_1, t_0, k_{-1}), s_{1,i})$.

In the second block, the encoder chooses the indices (m_2, k_0) uniformly at random and then to generate a secret key shared between the transmitter and the receiver, chooses the index ℓ_1 according to distribution with $j = 1$,

$$f(\ell_j | s_j^r) = \frac{P_{S|V}^{\otimes r}(s_j^r | v^r(\ell_j))}{\sum_{\ell' \in \llbracket 1, 2^{r\tilde{R}} \rrbracket} P_{S|V}^{\otimes r}(s_j^r | v^r(\ell'))}, \quad (185)$$

where $P_{S|V}^{\otimes r}$ is defined from the ideal PMF in (184). Then generates the reconciliation index $t_1 = \varphi(v^r)$; simultaneously the transmitter generates a key $k_1 = \Phi(v^r(\ell_1))$ from the description of its CSI of the first block v_1^r to be used in the next block. Base on these indices the encoder computes $u^r(m_2, t_1, k_0)$ and transmits a codeword x^r , where $x_i = x(u_i(m_2, t_1, k_0), s_{2,i})$.

In block $j \in \llbracket 3, B \rrbracket$, the encoder first selects the index ℓ_{j-1} based s_{j-1}^r by using the likelihood encoder described in (185) and then generates the reconciliation index $t_{j-1} = \varphi(v^r(\ell_{j-1}))$; simultaneously the transmitter generates a key $k_{j-1} = \Phi(v^r(\ell_{j-1}))$ from the description of its CSI of the block $j - 1$, $v^r(\ell_{j-1})$, to be used in the next block. Then to send message m_j and reconciliation index t_{j-1} according to the generated key k_{j-2} from the previous

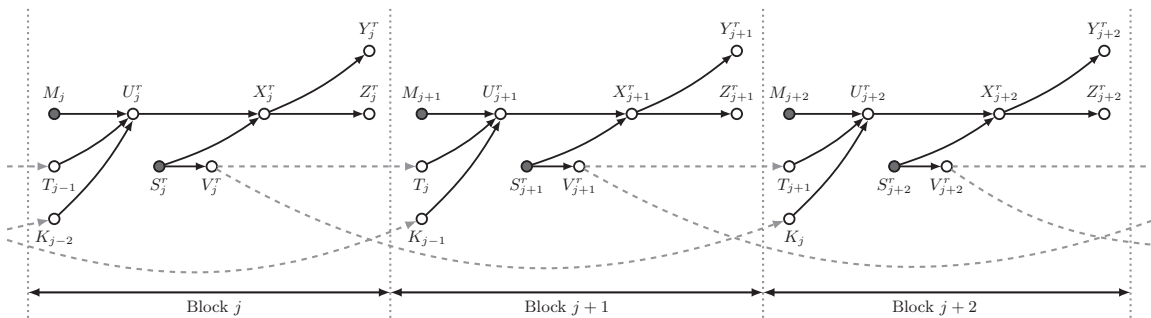

Fig. 10. Functional dependence graph for the block-Markov encoding scheme

block and the CSI of the current block s_j^r , the encoder computes $u^r(m_j, t_{j-1}, k_{j-2})$ and transmits a codeword x^r , where each coordinate of the transmitted signal is a function of the current state s_j^r as well as the corresponding sample of the transmitter's codeword u_i , i.e., $x_i = x(u_i(m_j, t_{j-1}, k_{j-2}), s_{j,i})$.

Define

$$\begin{aligned} \Upsilon_{M_j, T_{j-1}, K_{j-2}, U_j^r, S_j^r, L_j, V_j^r, Z_j^r, K_{j-1}, K_j, T_j}^{(C_n)}(m_j, t_{j-1}, k_{j-2}, \tilde{u}^r, s_j^r, \ell_j, \tilde{v}^r, z_j^r, k_{j-1}, k_j, t_j) \\ \triangleq 2^{-r(R+R_t+R_k)} \times \mathbb{1}_{\{u^r(m_j, t_{j-1}, k_{j-2}) = \tilde{u}^r\}} \times Q_S^{\otimes r}(s_j^r) \times f(\ell_j | s_j^r) \times \mathbb{1}_{\{v^r(\ell_j) = \tilde{v}^r\}} \\ \times W_{Z|U, S}^{\otimes r}(z_j^r | \tilde{u}^r, s_j^r) \times 2^{-rR_k} \times \mathbb{1}_{\{\varphi(\tilde{v}^r) = t_j\}} \times \mathbb{1}_{\{\Phi(\tilde{v}^r) = k_j\}}. \end{aligned} \quad (186)$$

For a fixed codebook C_n , the induced joint distribution over the codebook (i.e. $P^{(C_n)}$) satisfies

$$\|P_{M_j, T_{j-1}, K_{j-2}, U_j^r, S_j^r, L_j, V_j^r, Z_j^r, K_{j-1}, K_j, T_j}^{(C_n)} - \Upsilon_{M_j, T_{j-1}, K_{j-2}, U_j^r, S_j^r, L_j, V_j^r, Z_j^r, K_{j-1}, K_j, T_j}^{(C_n)}\|_1 \leq \epsilon. \quad (187)$$

This intermediate distribution $\Upsilon^{(C_n)}$ approximates the true distribution $P^{(C_n)}$ and will be used in the sequel for bounding purposes. Expression (187) holds because the main difference in $\Upsilon^{(C_n)}$ is assuming the keys K_{j-2} , K_{j-1} and the reconciliation index T_{j-1} are uniformly distributed, which is made (arbitrarily) nearly uniform in $P^{(C_n)}$ with appropriate control of rate.

Covert Analysis: We now show that this coding scheme guarantees that $\mathbb{E}_{C_n}[\mathbb{D}(P_{Z^n}^{(C_n)} || Q_Z^{\otimes n})] \xrightarrow{n \rightarrow \infty} 0$. Similar to (123) using the functional dependence graph depicted in Fig. 10 it follows that

$$\mathbb{D}(P_{Z^n}^{(C_n)} || Q_Z^{\otimes n}) \leq 2 \sum_{j=1}^B \mathbb{D}(P_{Z_j^r, K_{j-1}, K_j, T_j}^{(C_n)} || Q_Z^{\otimes r} Q_{K_{j-1}} Q_{K_j} Q_{T_j}). \quad (188)$$

Using the triangle inequality

$$\begin{aligned} \mathbb{E}_{C_n} \|P_{Z_j^r, K_{j-1}, K_j, T_j}^{(C_n)} - Q_Z^{\otimes r} Q_{K_{j-1}} Q_{K_j} Q_{T_j}\|_1 &\leq \\ \mathbb{E}_{C_n} \|P_{Z_j^r, K_{j-1}, K_j, T_j}^{(C_n)} - \Gamma_{Z_j^r, K_{j-1}, K_j, T_j}^{(C_n)}\|_1 &+ \mathbb{E}_{C_n} \|\Gamma_{Z_j^r, K_{j-1}, K_j, T_j}^{(C_n)} - Q_Z^{\otimes r} Q_{K_{j-1}} Q_{K_j} Q_{T_j}\|_1 \\ \leq \mathbb{E}_{C_n} \|P_{Z_j^r, K_{j-1}, K_j, T_j}^{(C_n)} - \Upsilon_{Z_j^r, K_{j-1}, K_j, T_j}^{(C_n)}\|_1 &+ \mathbb{E}_{C_n} \|\Upsilon_{Z_j^r, K_{j-1}, K_j, T_j}^{(C_n)} - \Gamma_{Z_j^r, K_{j-1}, K_j, T_j}^{(C_n)}\|_1 \\ + \mathbb{E}_{C_n} \|\Gamma_{Z_j^r, K_{j-1}, K_j, T_j}^{(C_n)} - Q_Z^{\otimes r} Q_{K_{j-1}} Q_{K_j} Q_{T_j}\|_1. & \end{aligned} \quad (189)$$

From (187) the first term on the RHS of (189) goes to zero when n grows. To bound the second term on the RHS of (189)

$$\Gamma_{M_j, T_{j-1}, K_{j-2}}^{(C_n)} = 2^{-r(R+R_t+R_k)} = P_{M_j, T_{j-1}, K_{j-2}}^{(C_n)}, \quad (190)$$

$$\Gamma_{U^r | M_j, T_{j-1}, K_{j-2}, S_j^r}^{(C_n)} = \mathbb{1}_{\{u^r(m_j, t_{j-1}, k_{j-2}) = \tilde{u}^r\}} = \Upsilon_{U^r | M_j, T_{j-1}, K_{j-2}, S_j^r}^{(C_n)}, \quad (191)$$

$$\Gamma_{L_j|M_j, T_{j-1}, K_{j-2}, S_j^r, U^r}^{(\mathcal{C}_n)} = f(\ell_j|s_j^r) = \Upsilon_{L_j|M_j, T_{j-1}, K_{j-2}, S_j^r, U^r}^{(\mathcal{C}_n)}, \quad (192)$$

$$\Gamma_{V^r|M_j, T_{j-1}, K_{j-2}, S_j^r, L_j, U^r}^{(\mathcal{C}_n)} = \mathbb{1}_{\{v^r(\ell_j)=\tilde{v}^r\}} = \Upsilon_{V^r|M_j, T_{j-1}, K_{j-2}, S_j^r, L_j, U^r}^{(\mathcal{C}_n)}, \quad (193)$$

$$\Gamma_{Z_j^r|M_j, T_{j-1}, K_{j-2}, S_j^r, L_j, U^r, V_j^r}^{(\mathcal{C}_n)} = W_{Z|U, S}^{\otimes r} = \Upsilon_{Z_j^r|M_j, T_{j-1}, K_{j-2}, S_j^r, L_j, U^r, V_j^r}^{(\mathcal{C}_n)}, \quad (194)$$

$$\Gamma_{K_{j-1}|M_j, T_{j-1}, K_{j-2}, S_j^r, L_j, U^r, V_j^r, Z_j^r}^{(\mathcal{C}_n)} = 2^{-rR_k} = \Upsilon_{K_{j-1}|M_j, T_{j-1}, K_{j-2}, S_j^r, L_j, U^r, V_j^r, Z_j^r}^{(\mathcal{C}_n)}, \quad (195)$$

$$\Gamma_{T_j|M_j, T_{j-1}, K_{j-2}, S_j^r, L_j, U^r, V_j^r, Z_j^r}^{(\mathcal{C}_n)} = \mathbb{1}_{\{\sigma(v_j^r)=t_j\}} = \Upsilon_{T_j|M_j, T_{j-1}, K_{j-2}, S_j^r, L_j, U^r, V_j^r, Z_j^r}^{(\mathcal{C}_n)}, \quad (196)$$

$$\Gamma_{K_j|M_j, T_{j-1}, K_{j-2}, S_j^r, L_j, U^r, V_j^r, Z_j^r, T_j}^{(\mathcal{C}_n)} = \mathbb{1}_{\{\Phi(v_j^r)=k_j\}} = \Upsilon_{K_j|M_j, T_{j-1}, K_{j-2}, S_j^r, L_j, U^r, V_j^r, Z_j^r, T_j}^{(\mathcal{C}_n)}, \quad (197)$$

where (192) follows from (185). Hence,

$$\begin{aligned} & \mathbb{E}_{\mathcal{C}_n} \|\Upsilon_{Z_j^r, K_{j-1}, K_j, T_j}^{(\mathcal{C}_n)} - \Gamma_{Z_j^r, K_{j-1}, K_j, T_j}^{(\mathcal{C}_n)}\|_1 \\ & \leq \mathbb{E}_{\mathcal{C}_n} \|\Upsilon_{M_j, T_{j-1}, K_{j-2}, S_j^r, L_j, U^r, V_j^r, Z_j^r, K_{j-1}, T_j, K_j}^{(\mathcal{C}_n)} - \Gamma_{M_j, T_{j-1}, K_{j-2}, S_j^r, L_j, U^r, V_j^r, Z_j^r, K_{j-1}, T_j, K_j}^{(\mathcal{C}_n)}\|_1 \\ & \stackrel{(a)}{=} \mathbb{E}_{\mathcal{C}_n} \|\Upsilon_{M_j, T_{j-1}, K_{j-2}, S_j^r}^{(\mathcal{C}_n)} - \Gamma_{M_j, T_{j-1}, K_{j-2}, S_j^r}^{(\mathcal{C}_n)}\|_1 \\ & \stackrel{(b)}{=} \mathbb{E}_{\mathcal{C}_n} \|Q_S^{\otimes r} - \Gamma_{S_j^r|M_j=1, T_{j-1}=1, K_{j-2}=1}^{(\mathcal{C}_n)}\|_1, \end{aligned} \quad (198)$$

where (a) follows from (191)-(197) and (b) follows from the symmetry of the codebook construction with respect to M_j , T_{j-1} , and K_{j-2} and (190). Based on the soft covering lemma [28, Corollary VII.5] the RHS of (198) vanishes if

$$\tilde{R} > \mathbb{I}(S; V). \quad (199)$$

We now proceed to bound the third term on the RHS of (189). First, consider the marginal

$$\begin{aligned} \Gamma_{Z_j^r, K_{j-1}, K_j, T_j}^{(\mathcal{C}_n)}(z_j^r, k_{j-1}, k_j, t_j) &= \sum_{m_j} \sum_{t_{j-1}} \sum_{k_{j-2}} \sum_{\ell_j} \sum_{s_j^r} \frac{1}{2^{r(R+R_t+2R_k+\tilde{R})}} \times P_{S|V}^{\otimes r}(s_j^r|v^r(\ell_j)) \\ & \times W_{Z|U, S}^{\otimes r}(z_j^r|u^r(m_j, t_{j-1}, k_{j-2}), s_j^r) \times \mathbb{1}_{\{\varphi(v_j^r(\ell_j))=t_j\}} \times \mathbb{1}_{\{\Phi(v_j^r(\ell_j))=k_j\}}. \end{aligned} \quad (200)$$

We now bound $\mathbb{E}_{\mathcal{C}_n} [\mathbb{D}(\Gamma_{Z_j^r, K_{j-1}, K_j, T_j}^{(\mathcal{C}_n)} \| Q_Z^{\otimes r} Q_{K_{j-1}} Q_{T_j} Q_{K_j})]$ as follows

$$\begin{aligned} & \mathbb{E}_{\mathcal{C}_n} [\mathbb{D}(\Gamma_{Z_j^r, K_{j-1}, K_j, T_j}^{(\mathcal{C}_n)} \| Q_Z^{\otimes r} Q_{K_{j-1}} Q_{T_j} Q_{K_j})] \\ &= \mathbb{E}_{\mathcal{C}_n} \left[\sum_{z_j^r, k_{j-1}, k_j, t_j} \Gamma^{(\mathcal{C}_n)}(z_j^r, k_{j-1}, k_j, t_j) \log \left(\frac{\Gamma^{(\mathcal{C}_n)}(z_j^r, k_{j-1}, k_j, t_j)}{Q_Z^{\otimes r}(z_j^r) \times Q_{K_{j-1}}(k_{j-1}) \times Q_{T_j}(t_j) \times Q_{K_j}(k_j)} \right) \right] \\ &= \mathbb{E}_{\mathcal{C}_n} \left[\sum_{z_j^r, k_{j-1}, k_j, t_j} \sum_{m_j} \sum_{t_{j-1}} \sum_{k_{j-2}} \sum_{\ell_j} \sum_{s_j^r} \frac{1}{2^{r(R+R_t+2R_k+\tilde{R})}} \times P_{S|V}^{\otimes r}(s_j^r|v_j^r(\ell_j)) \right. \\ & \times W_{Z|U, S}^{\otimes r}(z_j^r|u^r(m_j, t_{j-1}, k_{j-2}), s_j^r) \times \mathbb{1}_{\{\varphi(v_j^r(\ell_j))=t_j\}} \times \mathbb{1}_{\{\Phi(v_j^r(\ell_j))=k_j\}} \\ & \times \log \left(\frac{1}{2^{r(R+R_t+R_k+\tilde{R}-R_T-R_K)} \times Q_Z^{\otimes r}(z_j^r)} \right. \\ & \times \sum_{\tilde{m}_j} \sum_{\tilde{t}_{j-1}} \sum_{\tilde{k}_{j-2}} \sum_{\tilde{\ell}_j} \sum_{\tilde{s}_j^r} P_{S|V}^{\otimes r}(\tilde{s}_j^r|v_j^r(\tilde{\ell}_j)) \times W_{Z|U, S}^{\otimes r}(z_j^r|u^r(\tilde{m}_j, \tilde{t}_{j-1}, \tilde{k}_{j-2}), \tilde{s}_j^r) \\ & \left. \left. \times \mathbb{1}_{\{\varphi(v_j^r(\tilde{\ell}_j))=t_j\}} \times \mathbb{1}_{\{\Phi(v_j^r(\tilde{\ell}_j))=k_j\}} \right) \right] \end{aligned}$$

$$\begin{aligned}
&\stackrel{(a)}{\leq} \sum_{z_j^r, k_{j-1}, k_j, t_j} \sum_{m_j} \sum_{t_{j-1}} \sum_{k_{j-2}} \sum_{\ell_j} \frac{1}{2^{r(R+R_t+2R_k+\tilde{R})}} \sum_{u^r(m_j, t_{j-1}, k_{j-2}), s_j^r, v_j^r(\ell_j)} \Gamma_{U^r, S_j^r, V_j^r, Z_j^r}^{(C_n)}(u^r(m_j, t_{j-1}, k_{j-2}), s_j^r, v_j^r(\ell_j), z_j^r) \\
&\times \mathbb{E}_{\varphi(v_j^r(\ell_j))} \left[\mathbb{1}_{\{\varphi(v_j^r(\ell_j))=t_j\}} \right] \times \mathbb{E}_{\Phi(v_j^r(\ell_j))} \left[\mathbb{1}_{\{\Phi(v_j^r(\ell_j))=k_j\}} \right] \\
&\times \log \mathbb{E}_{\substack{\setminus(m_j, t_{j-1}, k_{j-2}, \ell_j), \\ \setminus(\varphi(v_j^r(\ell_j)), \Phi(v_j^r(\ell_j)))}} \left[\frac{1}{2^{r(R+R_t+R_k+\tilde{R}-R_T-R_K)} \times Q_Z^{\otimes r}(z_j^r)} \right. \\
&\times \left. \sum_{\tilde{m}_j} \sum_{\tilde{t}_{j-1}} \sum_{\tilde{k}_{j-2}} \sum_{\tilde{\ell}_j} \sum_{\tilde{s}_j^r} P_{S|V}^{\otimes r}(\tilde{s}_j^r | v_j^r(\tilde{\ell}_j)) \times W_{Z|U, S}^{\otimes r}(z_j^r | u^r(\tilde{m}_j, \tilde{t}_{j-1}, \tilde{k}_{j-2}), \tilde{s}_j^r) \times \mathbb{1}_{\{\varphi(v_j^r(\tilde{\ell}_j))=t_j\}} \times \mathbb{1}_{\{\Phi(v_j^r(\tilde{\ell}_j))=k_j\}} \right] \\
&\stackrel{(b)}{\leq} \sum_{z_j^r, k_{j-1}, k_j, t_j} \sum_{m_j} \sum_{t_{j-1}} \sum_{k_{j-2}} \sum_{\ell_j} \frac{1}{2^{r(R+R_t+2R_k+\tilde{R})}} \sum_{u^r(m_j, t_{j-1}, k_{j-2}), s_j^r, v_j^r(\ell_j)} \Gamma_{U^r, S_j^r, V_j^r, Z_j^r}^{(C_n)}(u^r(m_j, t_{j-1}, k_{j-2}), s_j^r, v_j^r(\ell_j), z_j^r) \\
&\times \frac{1}{2^{rR_T}} \times \frac{1}{2^{rR_K}} \times \log \left(\frac{P_{S|V}^{\otimes r}(s_j^r | v_j^r(\ell_j)) \times W_{Z|U, S}^{\otimes r}(z_j^r | u^r(m_j, t_{j-1}, k_{j-2}), s_j^r)}{2^{r(R+R_t+R_k+\tilde{R}-R_T-R_K)} \times Q_Z^{\otimes r}(z_j^r)} \right) \\
&+ \mathbb{E}_{\setminus(m_j, t_{j-1}, k_{j-2})} \left[\frac{\sum_{(\tilde{m}_j, \tilde{t}_{j-1}, \tilde{k}_{j-2}) \neq (m_j, t_{j-1}, k_{j-2})} P_{S|V}^{\otimes r}(s_j^r | v_j^r(\ell_j)) \times W_{Z|U, S}^{\otimes r}(z_j^r | u^r(\tilde{m}_j, \tilde{t}_{j-1}, \tilde{k}_{j-2}), s_j^r)}{2^{r(R+R_t+R_k+\tilde{R}-R_T-R_K)} \times Q_Z^{\otimes r}(z_j^r)} \right] \\
&+ \frac{\sum_{\tilde{s}_j^r \neq s_j^r} P_{S|V}^{\otimes r}(\tilde{s}_j^r | v_j^r(\ell_j)) \times W_{Z|U, S}^{\otimes r}(z_j^r | u^r(m_j, t_{j-1}, k_{j-2}), \tilde{s}_j^r)}{2^{r(R+R_t+R_k+\tilde{R}-R_T-R_K)} \times Q_Z^{\otimes r}(z_j^r)} \\
&+ \mathbb{E}_{\setminus(\varphi(v_j^r(\ell_j)), \Phi(v_j^r(\ell_j)))} \left[\frac{1}{2^{r(R+R_t+R_k+\tilde{R}-R_T-R_K)} \times Q_Z^{\otimes r}(z_j^r)} \right. \\
&\times \left. \sum_{\tilde{s}_j^r \neq s_j^r} \sum_{\tilde{\ell}_j \neq \ell_j} P_{S|V}^{\otimes r}(\tilde{s}_j^r | v_j^r(\tilde{\ell}_j)) \times W_{Z|U, S}^{\otimes r}(z_j^r | u^r(m_j, t_{j-1}, k_{j-2}), \tilde{s}_j^r) \times \mathbb{1}_{\{\varphi(v_j^r(\tilde{\ell}_j))=t_j\}} \times \mathbb{1}_{\{\Phi(v_j^r(\tilde{\ell}_j))=k_j\}} \right] \\
&+ \mathbb{E}_{\setminus(m_j, t_{j-1}, k_{j-2})} \left[\frac{\sum_{\tilde{s}_j^r \neq s_j^r} \sum_{(\tilde{m}_j, \tilde{t}_{j-1}, \tilde{k}_{j-2}) \neq (m_j, t_{j-1}, k_{j-2})} P_{S|V}^{\otimes r}(\tilde{s}_j^r | v_j^r(\ell_j)) \times W_{Z|U, S}^{\otimes r}(z_j^r | u^r(\tilde{m}_j, \tilde{t}_{j-1}, \tilde{k}_{j-2}), \tilde{s}_j^r)}{2^{r(R+R_t+R_k+\tilde{R}-R_T-R_K)} \times Q_Z^{\otimes r}(z_j^r)} \right] \\
&+ \mathbb{E}_{\setminus(\varphi(v_j^r(\ell_j)), \Phi(v_j^r(\ell_j)))} \left[\frac{1}{2^{r(R+R_t+R_k+\tilde{R}-R_T-R_K)} \times Q_Z^{\otimes r}(z_j^r)} \right. \\
&\times \left. \sum_{\tilde{\ell}_j \neq \ell_j} P_{S|V}^{\otimes r}(s_j^r | v_j^r(\tilde{\ell}_j)) \times W_{Z|U, S}^{\otimes r}(z_j^r | u^r(m_j, t_{j-1}, k_{j-2}), s_j^r) \times \mathbb{1}_{\{\varphi(v_j^r(\tilde{\ell}_j))=t_j\}} \times \mathbb{1}_{\{\Phi(v_j^r(\tilde{\ell}_j))=k_j\}} \right] \\
&+ \mathbb{E}_{\setminus(m_j, t_{j-1}, k_{j-2}, \ell_j), \setminus(\varphi(v_j^r(\ell_j)), \Phi(v_j^r(\ell_j)))} \left[\frac{1}{2^{r(R+R_t+R_k+\tilde{R}-R_T-R_K)} \times Q_Z^{\otimes r}(z_j^r)} \right. \\
&\times \left. \sum_{\tilde{s}_j^r} \sum_{\tilde{\ell}_j \neq \ell_j} \sum_{(\tilde{m}_j, \tilde{t}_{j-1}, \tilde{k}_{j-2}) \neq (m_j, t_{j-1}, k_{j-2})} P_{S|V}^{\otimes r}(\tilde{s}_j^r | v_j^r(\tilde{\ell}_j)) \times W_{Z|U, S}^{\otimes r}(z_j^r | u^r(\tilde{m}_j, \tilde{t}_{j-1}, \tilde{k}_{j-2}), \tilde{s}_j^r) \right. \\
&\times \left. \mathbb{1}_{\{\varphi(v_j^r(\tilde{\ell}_j))=t_j\}} \times \mathbb{1}_{\{\Phi(v_j^r(\tilde{\ell}_j))=k_j\}} \right] \\
&\stackrel{(c)}{\leq} \sum_{z_j^r, k_{j-1}, k_j, t_j} \sum_{m_j} \sum_{t_{j-1}} \sum_{k_{j-2}} \sum_{\ell_j} \frac{1}{2^{r(R+R_t+2R_k+\tilde{R})}} \sum_{u^r(m_j, t_{j-1}, k_{j-2}), s_j^r, v_j^r(\ell_j)} \Gamma_{U^r, S_j^r, V_j^r, Z_j^r}^{(C_n)}(u^r(m_j, t_{j-1}, k_{j-2}), s_j^r, v_j^r(\ell_j), z_j^r) \\
&\times \frac{1}{2^{rR_T}} \times \frac{1}{2^{rR_K}} \times \log \left(\frac{P_{S|V}^{\otimes r}(s_j^r | v_j^r(\ell_j)) \times W_{Z|U, S}^{\otimes r}(z_j^r | u^r(m_j, t_{j-1}, k_{j-2}), s_j^r)}{2^{r(R+R_t+R_k+\tilde{R}-R_T-R_K)} \times Q_Z^{\otimes r}(z_j^r)} \right)
\end{aligned}$$

$$\begin{aligned}
& + \frac{\sum_{(\tilde{m}_j, \tilde{t}_{j-1}, \tilde{k}_{j-2}) \neq (m_j, t_{j-1}, k_{j-2})} P_{S|V}^{\otimes r}(s_j^r | v_j^r(\ell_j)) \times W_{Z|S}^{\otimes r}(z_j^r | s_j^r)}{2^{r(R+R_t+R_k+\tilde{R}-R_T-R_K)} \times Q_Z^{\otimes r}(z_j^r)} \\
& + \frac{\sum_{\tilde{s}_j^r \neq s_j^r} P_{S|V}^{\otimes r}(\tilde{s}_j^r | v_j^r(\ell_j)) \times W_{Z|U,S}^{\otimes r}(z_j^r | u^r(m_j, t_{j-1}, k_{j-2}), \tilde{s}_j^r)}{2^{r(R+R_t+R_k+\tilde{R}-R_T-R_K)} \times Q_Z^{\otimes r}(z_j^r)} \\
& + \frac{\sum_{\tilde{s}_j^r \neq s_j^r} Q_S^{\otimes r}(\tilde{s}_j^r) \times W_{Z|U,S}^{\otimes r}(z_j^r | u^r(m_j, t_{j-1}, k_{j-2}), \tilde{s}_j^r)}{2^{r(R+R_t+R_k+\tilde{R})} \times Q_Z^{\otimes r}(z_j^r)} \\
& + \frac{\sum_{\tilde{s}_j^r \neq s_j^r} \sum_{(\tilde{m}_j, \tilde{t}_{j-1}, \tilde{k}_{j-2}) \neq (m_j, t_{j-1}, k_{j-2})} P_{S|V}^{\otimes r}(\tilde{s}_j^r | v_j^r(\ell_j)) \times W_{Z|S}^{\otimes r}(z_j^r | \tilde{s}_j^r)}{2^{r(R+R_t+R_k+\tilde{R}-R_T-R_K)} \times Q_Z^{\otimes r}(z_j^r)} \\
& + \frac{\sum_{\tilde{\ell}_j \neq \ell_j} Q_S^{\otimes r}(s_j^r) \times W_{Z|U,S}^{\otimes r}(z_j^r | u^r(m_j, t_{j-1}, k_{j-2}), s_j^r)}{2^{r(R+R_t+R_k+\tilde{R})} \times Q_Z^{\otimes r}(z_j^r)} + 1 \Big) \\
& \triangleq \Psi_1 + \Psi_2, \tag{201}
\end{aligned}$$

where (a) follows from Jensen's inequality, (b) and (c) hold because $\mathbb{1}_{\{\Phi(s_j^r)=k_j\}} \leq 1$. We defined Ψ_1 and Ψ_2 as

$$\begin{aligned}
\Psi_1 & = \sum_{k_{j-1}, k_j, t_j} \sum_{m_j} \sum_{t_{j-1}} \sum_{k_{j-2}} \sum_{\ell_j} \frac{1}{2^{r(R+R_t+2R_k+R_T+R_K)}} \\
& \quad \times \sum_{(s_j^r, v_j^r, u^r(m_j, t_{j-1}, k_{j-2}), z_j^r) \in T_e^{(n)}} \Gamma_{S^r, V^r, U^r, Z^r}^{(C_n)}(s_j^r, v_j^r, u^r(m_j, t_{j-1}, k_{j-2}), z_j^r) \\
& \quad \times \log \left(\frac{P_{S|V}^{\otimes r}(s_j^r | v_j^r(\ell_j)) \times W_{Z|U,S}^{\otimes r}(z_j^r | u^r(m_j, t_{j-1}, k_{j-2}), s_j^r)}{2^{r(R+R_t+R_k+\tilde{R}-R_T-R_K)} \times Q_Z^{\otimes r}(z_j^r)} \right. \\
& \quad + \frac{\sum_{(\tilde{m}_j, \tilde{t}_{j-1}, \tilde{k}_{j-2}) \neq (m_j, t_{j-1}, k_{j-2})} P_{S|V}^{\otimes r}(s_j^r | v_j^r(\ell_j)) \times W_{Z|S}^{\otimes r}(z_j^r | s_j^r)}{2^{r(R+R_t+R_k+\tilde{R}-R_T-R_K)} \times Q_Z^{\otimes r}(z_j^r)} \\
& \quad + \frac{\sum_{\tilde{s}_j^r \neq s_j^r} P_{S|V}^{\otimes r}(\tilde{s}_j^r | v_j^r(\ell_j)) \times W_{Z|U,S}^{\otimes r}(z_j^r | u^r(m_j, t_{j-1}, k_{j-2}), \tilde{s}_j^r)}{2^{r(R+R_t+R_k+\tilde{R}-R_T-R_K)} \times Q_Z^{\otimes r}(z_j^r)} \\
& \quad + \frac{\sum_{\tilde{s}_j^r \neq s_j^r} \sum_{\tilde{\ell}_j \neq \ell_j} Q_S^{\otimes r}(\tilde{s}_j^r) \times W_{Z|U,S}^{\otimes r}(z_j^r | u^r(m_j, t_{j-1}, k_{j-2}), \tilde{s}_j^r)}{2^{r(R+R_t+R_k+\tilde{R})} \times Q_Z^{\otimes r}(z_j^r)} \\
& \quad + \frac{\sum_{\tilde{s}_j^r \neq s_j^r} \sum_{(\tilde{m}_j, \tilde{t}_{j-1}, \tilde{k}_{j-2}) \neq (m_j, t_{j-1}, k_{j-2})} P_{S|V}^{\otimes r}(\tilde{s}_j^r | v_j^r(\ell_j)) \times W_{Z|S}^{\otimes r}(z_j^r | \tilde{s}_j^r)}{2^{r(R+R_t+R_k+\tilde{R}-R_T-R_K)} \times Q_Z^{\otimes r}(z_j^r)} \\
& \quad \left. + \frac{\sum_{\tilde{\ell}_j \neq \ell_j} Q_S^{\otimes r}(s_j^r) \times W_{Z|U,S}^{\otimes r}(z_j^r | u^r(m_j, t_{j-1}, k_{j-2}), s_j^r)}{2^{r(R+R_t+R_k+\tilde{R})} \times Q_Z^{\otimes r}(z_j^r)} + 1 \right) \\
& \leq \sum_{k_{j-1}, k_j, t_j} \sum_{m_j} \sum_{t_{j-1}} \sum_{k_{j-2}} \sum_{\ell_j} \frac{1}{2^{r(R+R_t+2R_k+R_T+R_K)}} \\
& \quad \times \sum_{(s_j^r, v_j^r, u^r(m_j, t_{j-1}, k_{j-2}), z_j^r) \in T_e^{(n)}} \Gamma_{S^r, V^r, U^r, Z^r}^{(C_n)}(s_j^r, v_j^r, u^r(m_j, t_{j-1}, k_{j-2}), z_j^r)
\end{aligned}$$

$$\begin{aligned}
& \times \log \left(\frac{P_{S|V}^{\otimes r}(s_j^r | v_j^r(\ell_j)) \times W_{Z|U,S}^{\otimes r}(z_j^r | u^r(m_j, t_{j-1}, k_{j-2}), s_j^r)}{2^{r(R+R_t+R_k+\tilde{R}-R_T-R_K)} \times Q_Z^{\otimes r}(z_j^r)} + \frac{P_{S|V}^{\otimes r}(s_j^r | v_j^r(\ell_j)) \times W_{Z|S}^{\otimes r}(z_j^r | s_j^r)}{2^{r(\tilde{R}-R_T-R_K)} \times Q_Z^{\otimes r}(z_j^r)} \right. \\
& + \frac{W_{Z|U}^{\otimes r}(z_j^r | u^r(k_{j-2}, t_{j-1}, m_j))}{2^{r(R+R_t+R_k+\tilde{R}-R_T-R_K)} \times Q_Z^{\otimes r}(z_j^r)} + \frac{W_{Z|U}^{\otimes r}(z_j^r | u^r(k_{j-2}, t_{j-1}, m_j))}{2^{r(R+R_t+R_k)} \times Q_Z^{\otimes r}(z_j^r)} \\
& \left. + \frac{Q_Z^{\otimes r}(z_j^r)}{2^{r(\tilde{R}-R_T-R_K)} \times Q_Z^{\otimes r}(z_j^r)} + \frac{Q_S^{\otimes r}(s_j^r) \times W_{Z|U,S}^{\otimes r}(z_j^r | u^r(k_{j-2}, t_{j-1}, m_j), s_j^r)}{2^{r(R+R_t+R_k)} \times Q_Z^{\otimes r}(z_j^r)} + 1 \right) \\
& \leq \log \left(\frac{2^{r(R_T+R_K)} \times 2^{-r(1-\epsilon)(\mathbb{H}(S|V)+\mathbb{H}(Z|U,S))}}{2^{r(R+R_t+R_k+\tilde{R})} \times 2^{-r(1+\epsilon)\mathbb{H}(Z)}} + \frac{2^{r(R_T+R_K)} \times 2^{-r(1-\epsilon)(\mathbb{H}(S|V)+\mathbb{H}(Z|S))}}{2^{r\tilde{R}} \times 2^{-r(1+\epsilon)\mathbb{H}(Z)}} \right. \\
& + \frac{2^{r(R_T+R_K)} \times 2^{-r(1-\epsilon)\mathbb{H}(Z|U)}}{2^{r(R+R_t+R_k+\tilde{R})} \times 2^{-r(1+\epsilon)\mathbb{H}(Z)}} + \frac{2^{-r(1-\epsilon)\mathbb{H}(Z|U)}}{2^{r(R+R_t+R_k)} \times 2^{-r(1+\epsilon)\mathbb{H}(Z)}} + \frac{2^{r(R_T+R_K)} \times 2^{-r(1-\epsilon)\mathbb{H}(Z)}}{2^{r\tilde{R}} \times 2^{-r(1+\epsilon)\mathbb{H}(Z)}} \\
& \left. + \frac{2^{-r(1-\epsilon)\mathbb{H}(S)} \times 2^{-r(1-\epsilon)\mathbb{H}(Z|U,S)}}{2^{r(R+R_t+R_k)} \times 2^{-r(1+\epsilon)\mathbb{H}(Z)}} + 1 \right) \tag{202}
\end{aligned}$$

$$\begin{aligned}
\Psi_2 &= \sum_{k_{j-1}, k_j, t_j} \sum_{m_j} \sum_{t_{j-1}} \sum_{k_{j-2}} \sum_{\ell_j} \frac{1}{2^{r(R+R_t+2R_k+R_T+R_K)}} \\
& \times \sum_{\substack{(s_j^r, v_j^r, u^r(m_j, t_{j-1}, k_{j-2}), z_j^r) \notin T_\epsilon^{(n)}}} \Gamma_{S^r, V^r, U^r, Z^r}^{(C_n)}(s_j^r, v_j^r, u^r(m_j, t_{j-1}, k_{j-2}), z_j^r) \\
& \times \log \left(\frac{P_{S|V}^{\otimes r}(s_j^r | v_j^r(\ell_j)) \times W_{Z|U,S}^{\otimes r}(z_j^r | u^r(m_j, t_{j-1}, k_{j-2}), s_j^r)}{2^{r(R+R_t+R_k+\tilde{R}-R_T-R_K)} \times Q_Z^{\otimes r}(z_j^r)} \right. \\
& + \frac{\sum_{(\tilde{m}_j, \tilde{t}_{j-1}, \tilde{k}_{j-2}) \neq (m_j, t_{j-1}, k_{j-2})} \frac{P_{S|V}^{\otimes r}(s_j^r | v_j^r(\ell_j)) \times W_{Z|S}^{\otimes r}(z_j^r | s_j^r)}{2^{r(R+R_t+R_k+\tilde{R}-R_T-R_K)} \times Q_Z^{\otimes r}(z_j^r)}}{2^{r(R+R_t+R_k+\tilde{R}-R_T-R_K)} \times Q_Z^{\otimes r}(z_j^r)} \\
& + \frac{\sum_{\tilde{s}_j^r \neq s_j^r} P_{S|V}^{\otimes r}(\tilde{s}_j^r | v_j^r(\ell_j)) \times W_{Z|U,S}^{\otimes r}(z_j^r | u^r(m_j, t_{j-1}, k_{j-2}), \tilde{s}_j^r)}{2^{r(R+R_t+R_k+\tilde{R}-R_T-R_K)} \times Q_Z^{\otimes r}(z_j^r)} \\
& + \frac{\sum_{\tilde{s}_j^r \neq s_j^r} \sum_{\tilde{\ell}_j \neq \ell_j} Q_S^{\otimes r}(\tilde{s}_j^r) \times W_{Z|U,S}^{\otimes r}(z_j^r | u^r(m_j, t_{j-1}, k_{j-2}), \tilde{s}_j^r)}{2^{r(R+R_t+R_k+\tilde{R})} \times Q_Z^{\otimes r}(z_j^r)} \\
& + \frac{\sum_{\tilde{s}_j^r \neq s_j^r} \sum_{(\tilde{m}_j, \tilde{t}_{j-1}, \tilde{k}_{j-2}) \neq (m_j, t_{j-1}, k_{j-2})} \frac{P_{S|V}^{\otimes r}(\tilde{s}_j^r | v_j^r(\ell_j)) \times W_{Z|S}^{\otimes r}(z_j^r | \tilde{s}_j^r)}{2^{r(R+R_t+R_k+\tilde{R}-R_T-R_K)} \times Q_Z^{\otimes r}(z_j^r)}}{2^{r(R+R_t+R_k+\tilde{R}-R_T-R_K)} \times Q_Z^{\otimes r}(z_j^r)} \\
& \left. + \frac{\sum_{\tilde{\ell}_j \neq \ell_j} Q_S^{\otimes r}(s_j^r) \times W_{Z|U,S}^{\otimes r}(z_j^r | u^r(m_j, t_{j-1}, k_{j-2}), s_j^r)}{2^{r(R+R_t+R_k+\tilde{R})} \times Q_Z^{\otimes r}(z_j^r)} + 1 \right) \\
& \leq \sum_{k_{j-1}, k_j, t_j} \sum_{m_j} \sum_{t_{j-1}} \sum_{k_{j-2}} \sum_{\ell_j} \frac{1}{2^{r(R+R_t+2R_k+R_T+R_K)}} \\
& \times \sum_{\substack{(s_j^r, v_j^r, u^r(m_j, t_{j-1}, k_{j-2}), z_j^r) \notin T_\epsilon^{(n)}}} \Gamma_{S^r, V^r, U^r, Z^r}^{(C_n)}(s_j^r, v_j^r, u^r(m_j, t_{j-1}, k_{j-2}), z_j^r) \\
& \times \log \left(\frac{P_{S|V}^{\otimes r}(s_j^r | v_j^r(\ell_j)) \times W_{Z|U,S}^{\otimes r}(z_j^r | u^r(m_j, t_{j-1}, k_{j-2}), s_j^r)}{2^{r(R+R_t+R_k+\tilde{R}-R_T-R_K)} \times Q_Z^{\otimes r}(z_j^r)} + \frac{P_{S|V}^{\otimes r}(s_j^r | v_j^r(\ell_j)) \times W_{Z|S}^{\otimes r}(z_j^r | s_j^r)}{2^{r(\tilde{R}-R_T-R_K)} \times Q_Z^{\otimes r}(z_j^r)} \right. \\
& + \frac{W_{Z|U}^{\otimes r}(z_j^r | u^r(k_{j-2}, t_{j-1}, m_j))}{2^{r(R+R_t+R_k+\tilde{R}-R_T-R_K)} \times Q_Z^{\otimes r}(z_j^r)} + \frac{W_{Z|U}^{\otimes r}(z_j^r | u^r(k_{j-2}, t_{j-1}, m_j))}{2^{r(R+R_t+R_k)} \times Q_Z^{\otimes r}(z_j^r)} \\
& \left. + \frac{Q_S^{\otimes r}(s_j^r) \times W_{Z|U,S}^{\otimes r}(z_j^r | u^r(m_j, t_{j-1}, k_{j-2}), s_j^r)}{2^{r(R+R_t+R_k+\tilde{R})} \times Q_Z^{\otimes r}(z_j^r)} + 1 \right)
\end{aligned}$$

$$\begin{aligned}
& + \frac{Q_Z^{\otimes r}(z_j^r)}{2^{r(\tilde{R}-R_T-R_K)} \times Q_Z^{\otimes r}(z_j^r)} + \frac{Q_S^{\otimes r}(s_j^r) \times W_{Z|U,S}^{\otimes r}(z_j^r|u^r(k_{j-2}, t_{j-1}, m_j), s_j^r)}{2^{r(R+R_t+R_k)} \times Q_Z^{\otimes r}(z_j^r)} + 1 \Big) \\
& \leq 2|S||V||U||Z|e^{-r\varepsilon\mu_{S,V,U,Z}} r \log\left(\frac{4}{\mu_Z} + 1\right). \tag{203}
\end{aligned}$$

In (203) $\mu_{S,V,U,Z} = \min_{(s,v,u,z) \in (\mathcal{S}, \mathcal{V}, \mathcal{U}, \mathcal{Z})} P_{S,V,U,Z}(s, v, u, z)$ and $\mu_Z = \min_{z \in \mathcal{Z}} P_Z(z)$. When $r \rightarrow \infty$ then $\Psi_2 \rightarrow 0$ and Ψ_1 goes to zero when r grows if

$$R + R_t + R_k + \tilde{R} - R_T - R_K > \mathbb{I}(U, S; Z) - \mathbb{H}(S|V) \tag{204}$$

$$\tilde{R} - R_T - R_K > \mathbb{I}(S; Z) - \mathbb{H}(S|V) \tag{205}$$

$$R + R_t + R_k + \tilde{R} - R_T - R_K > \mathbb{I}(U; Z) \tag{206}$$

$$R + R_t + R_k > \mathbb{I}(U; Z) \tag{207}$$

$$\tilde{R} - R_T - R_K > 0 \tag{208}$$

$$R + R_t + R_k > \mathbb{I}(U, S; Z) - \mathbb{H}(S) \tag{209}$$

where (206) is redundant because of (207) and (208), also (209) is redundant because of (207).

Decoding and Error Probability Analysis: By following the same steps as in [6], the probability of error for decoding u^r vanishes when r grows if

$$R + R_t < \mathbb{I}(U; Y). \tag{210}$$

We now analyze the probability of error at the encoder and the decoder for key generation. Let (L_{j-1}, T_{j-1}) denote the chosen indices at the encoder and \hat{L}_{j-1} be the estimate of the index L_{j-1} at the decoder. At the end of block j , by decoding U_j^r , the receiver has access to T_{j-1} and to find L_{j-1} we define the error event

$$\mathcal{E} = \{(V_{j-1}^r(\hat{L}_{j-1}), S_{j-1}^r, U_{j-1}^r, Y_{j-1}^r) \notin \mathcal{T}_e^{(n)}\}, \tag{211}$$

and consider the events

$$\mathcal{E}_1 = \{(V_{j-1}^r(\ell_{j-1}), S_{j-1}^r) \notin \mathcal{T}_e^{(n)} \text{ for all } \ell_{j-1} \in \llbracket 1, 2^{r\tilde{R}} \rrbracket\}, \tag{212}$$

$$\mathcal{E}_2 = \{(V_{j-1}^r(L_{j-1}), S_{j-1}^r, U_{j-1}^r, Y_{j-1}^r) \notin \mathcal{T}_e^{(n)}\}, \tag{213}$$

$$\mathcal{E}_3 = \{(V_{j-1}^r(\tilde{\ell}_{j-1}), U_{j-1}^r, Y_{j-1}^r) \in \mathcal{T}_e^{(n)} \text{ for some } \ell_{j-1} \in \mathcal{B}(T_{j-1}), \tilde{\ell}_{j-1} \neq \ell_{j-1}\}. \tag{214}$$

By the union bound we have

$$P(\mathcal{E}) \leq P(\mathcal{E}_1) + P(\mathcal{E}_1^c \cap \mathcal{E}_2) + P(\mathcal{E}_3). \tag{215}$$

According to [29, Lemma 2] the first term on the RHS of (215) vanishes when r grows if we have (199). Following the steps in [24, Sec. 11.3.1], the last two terms on the right hand side of (215) go to zero when r grows if we have (199) and

$$\tilde{R} - R_t < \mathbb{I}(V; U, Y). \tag{216}$$

Input Cost Analysis: The proof follows similar lines to [6, Sec. V].

By applying Fourier-Motzkin to (199), (204), (205), (207), (208), (210), and (216) and remarking that the scheme requires $R_t + R_k \leq R_T + R_K$ the following region will be derived

$$R \leq \mathbb{I}(U; Y) - \mathbb{I}(V; S) + \mathbb{I}(V; U, Y), \tag{217}$$

$$\mathbb{I}(U; Y) + \mathbb{I}(V; U, Y) \geq \mathbb{I}(U; Z) + \mathbb{I}(S; Z) - \mathbb{H}(S|V), \quad (218)$$

$$\mathbb{I}(U; Y) + \mathbb{I}(V; U, Y) \geq \mathbb{I}(U; Z) \quad (219)$$

$$\mathbb{I}(U; Y) + \mathbb{I}(V; U, Y) \geq \mathbb{I}(U, S; Z) - \mathbb{H}(S|V). \quad (220)$$

where (218) is redundant because of (220).

APPENDIX G

PROOF OF THEOREM 7

We adopt a block-Markov encoding scheme in which $B - 1$ independent messages are transmitted over B channel blocks each of length r , such that $n = rB$. The warden's observation is $Z^n = (Z_1^r, \dots, Z_B^r)$, the target output distribution is $Q_Z^{\otimes n}$, and Equation (63), describing the distance between the two distributions, continues to hold. The random code generation is as follows:

Fix $P_U(u)$, $x(u, s)$, $P_{S,U,X,Y,Z}(s, u, x, y, z) = Q_S(s)P_U(u)\mathbb{1}\{x(u, s) = x\}W_{YZ|X,S}$, and $\epsilon_1 > \epsilon_2 > 0$ such that, $Q_Z = Q_0$ and $\mathbb{E}[g(X)] \leq \frac{\epsilon_2}{1 + \epsilon_2}$.

Codebook Generation for Keys: For each block $j \in \llbracket 1, B \rrbracket$, to generate a key K_j of rate R_K by using the channel state S_j^r , we use Lemma 3 and then, create function $\Phi : S_j^r \rightarrow \llbracket 1, 2^{rR_K} \rrbracket$ through random binning by choosing the value of $\Phi(S_j^r)$ independently and uniformly at random for every $S_j^r \in S^r$. The key $k_j = \Phi(s_j^r)$ obtained in block $j \in \llbracket 1, B \rrbracket$ from the state sequence s_j^r is used to assist the encoder in the block $j + 2$.

Codebook Generation for Messages: For each block $j \in \llbracket 1, B \rrbracket$ and for each $k_{j-2} \in \llbracket 1, 2^{rR_K} \rrbracket$, $t_{j-1} \in \llbracket 1, 2^{r\tilde{R}} \rrbracket$, and $m_j \in \llbracket 1, 2^{rR} \rrbracket$, randomly and independently generate a sequence $u^r(k_{j-2}, t_{j-1}, m_j)$ according to $\prod_{i=1}^r p(u_i)$. These constitute the codebook \mathcal{C}_n . The indices (k_{j-2}, t_{j-1}, m_j) can be viewed as a two layer binning.

Encoding: In the first block, the encoder chooses the indices (k_{-1}, t_0, m_1) uniformly at random. Based on these indices, computes $u^r(k_{-1}, t_0, m_1)$ and transmits codeword x^r , where $x_i = x(u_i(k_0, m_1, t_1), s_i)$.

In the second block, the encoder chooses the indices (k_0, m_2) uniformly at random and to generate a secret key shared between the transmitter and the receiver, it selects the reconciliation index $t_1 = \sigma(s_1^r)$; simultaneously the transmitter generates key $k_1 = \Phi(s_1^r)$ from its CSI of the first block s_1^r to be used in the next block. Base on these indices the encoder computes $u^r(k_0, t_1, m_2)$ and transmits codeword x^r , where $x_i = x(u_i(k_0, t_1, m_2), s_i)$.

In the block $j \in \llbracket 3, B \rrbracket$, to send message m_j and reconciliation index t_{j-1} according to the generated key k_{j-2} from the previous block and the CSI of the current block s_j^r , the encoder computes $u^r(k_{j-2}, t_{j-1}, m_j)$ and transmits codeword x^r , where each coordinate of the transmitted signal is a function of the current state, as well as the corresponding sample of the transmitter's codeword u_i , i.e., $x_i = x(u_i(k_{j-2}, t_{j-1}, m_j), s_i)$. Simultaneously the transmitter generates key $k_{j-1} = \Phi(s_{j-1}^r)$ from its CSI of the previous block s_{j-1}^r to be used in the next block.

Define

$$\begin{aligned} \Upsilon_{K_{j-2}, T_{j-1}, M_j, U^r, S_j^r, Z_j^r, T_j, K_j}^{(\mathcal{C}_n)}(k_{j-2}, t_{j-1}, m_j, \tilde{u}^r, s_j^r, z_j^r, k_{j-1}, t_j, k_j) &\triangleq Q_S^{\otimes r}(s_j^r) \times 2^{-r(R_k + R_t + R)} \\ &\times \mathbb{1}\{u^r(k_{j-2}, t_{j-1}, m_j) = \tilde{u}^r\} \times W_{Z|U,S}^{\otimes r}(z_j^r | \tilde{u}^r, s_j^r) \times \mathbb{1}\{\sigma(s_j^r) = t_j\} \times \mathbb{1}\{\Phi(s_j^r) = k_j\}. \end{aligned} \quad (221)$$

For a fixed codebook \mathcal{C}_n , the induced joint distribution over the codebook (i.e. $P^{(\mathcal{C}_n)}$) satisfies

$$\|P_{K_{j-2}, T_{j-1}, M_j, U^r, S_j^r, Z_j^r, T_j, K_j}^{(\mathcal{C}_n)} - \Upsilon_{K_{j-2}, T_{j-1}, M_j, U^r, S_j^r, Z_j^r, T_j, K_j}^{(\mathcal{C}_n)}\|_1 \leq \epsilon. \quad (222)$$

This intermediate distribution $\Upsilon^{(\mathcal{C}_n)}$ approximates the true distribution $P^{(\mathcal{C}_n)}$ and will be used in the sequel for bounding purposes. Expression (222) holds because the main difference in $\Upsilon^{(\mathcal{C}_n)}$ is assuming the keys K_{j-2} , K_{j-1}

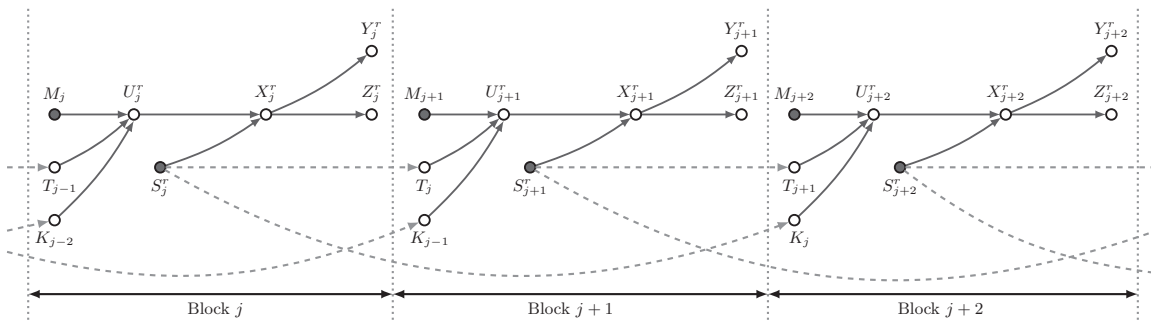

Fig. 11. Functional dependence graph for the block-Markov encoding scheme

and the reconciliation index T_{j-1} are uniformly distributed, which is made (arbitrarily) nearly uniform in $P^{(C_n)}$ with appropriate control of rate.

Covert Analysis: We now show that this coding scheme guarantees that $\mathbb{E}_{C_n} [\mathbb{D}(P_{Z^n}^{(C_n)} || Q_Z^{\otimes n})] \xrightarrow{n \rightarrow \infty} 0$. From the expansion in (63), for every $j \in \llbracket 2, B \rrbracket$,

$$\begin{aligned} \mathbb{I}(Z_j^r; Z_{j+1}^{B,r}) &\leq \mathbb{I}(Z_j^r; T_j, K_j, Z_{j+1}^{B,r}) \\ &\stackrel{(a)}{=} \mathbb{I}(Z_j^r; T_j, K_j), \end{aligned} \quad (223)$$

where (a) holds because $Z_j^r - (T_j, K_j) - Z_{j+1}^{B,r}$ forms a Markov chain, as seen in the functional dependence graph depicted in Fig. 11. Next,

$$\begin{aligned} \mathbb{I}(Z_j^r; T_j, K_j) &= \mathbb{D}(P_{Z_j^r, T_j, K_j}^{(C_n)} || P_{Z_j^r}^{(C_n)} P_{T_j, K_j}^{(C_n)}) \\ &\stackrel{(b)}{\leq} \mathbb{D}(P_{Z_j^r, T_j, K_j}^{(C_n)} || Q_Z^{\otimes r} Q_{T_j} Q_{K_j}), \end{aligned} \quad (224)$$

where $Q_{T_j} Q_{K_j}$ is the uniform distribution on $\llbracket 1, 2^{r\tilde{R}} \rrbracket \times \llbracket 1, 2^{rR\kappa} \rrbracket$ and (b) follows from

$$\mathbb{D}(P_{Z_j^r, T_j, K_j}^{(C_n)} || P_{Z_j^r}^{(C_n)} P_{T_j, K_j}^{(C_n)}) = \mathbb{D}(P_{Z_j^r, T_j, K_j}^{(C_n)} || Q_Z^{\otimes r} Q_{T_j} Q_{K_j}) - \mathbb{D}(P_{Z_j^r}^{(C_n)} || Q_Z^{\otimes r}) - \mathbb{D}(P_{T_j, K_j}^{(C_n)} || Q_{T_j} Q_{K_j}). \quad (225)$$

Therefore by combining (63), (224), and (225)

$$\mathbb{D}(P_{Z^n}^{(C_n)} || Q_Z^{\otimes n}) \leq 2 \sum_{j=1}^B \mathbb{D}(P_{Z_j^r, T_j, K_j}^{(C_n)} || Q_Z^{\otimes r} Q_{T_j} Q_{K_j}). \quad (226)$$

We now proceed to bound the RHS of (226). First, consider the marginal

$$\begin{aligned} \Upsilon_{Z_j^r, T_j, K_j}^{(C_n)}(z_j^r, t_j, k_j) &= \sum_{k_{j-2}} \sum_{t_{j-1}} \sum_{m_j} \sum_{s_j^r} \frac{1}{2^{r(R_k + R_t + R)}} \times Q_S^{\otimes r}(s_j^r) \times W_{Z|U,S}^{\otimes r}(z_j^r | u^r(k_{j-2}, t_{j-1}, m_j), s_j^r) \\ &\times \mathbb{1}_{\{\sigma(s_j^r) = t_j\}} \times \mathbb{1}_{\{\Phi(s_j^r) = k_j\}}. \end{aligned} \quad (227)$$

Therefore, from (222)

$$\|\Upsilon_{Z_j^r, T_j, K_j}^{(C_n)} - P_{Z_j^r, T_j, K_j}^{(C_n)}\|_1 \leq \epsilon. \quad (228)$$

To bound the RHS of (226) by using triangle inequality

$$\|P_{Z_j^r, T_j, K_j}^{(C_n)} - Q_Z^{\otimes r} Q_{T_j} Q_{K_j}\|_1 \leq \|P_{Z_j^r, T_j, K_j}^{(C_n)} - \Upsilon_{Z_j^r, T_j, K_j}^{(C_n)}\|_1 + \|\Upsilon_{Z_j^r, T_j, K_j}^{(C_n)} - Q_Z^{\otimes r} Q_{T_j} Q_{K_j}\|_1. \quad (229)$$

The first term on the RHS of (229) goes to zero as n grows, we now analyze the second term on RHS of (229) as follows

$$\begin{aligned}
& \mathbb{E}_{\mathcal{C}_n} [\mathbb{D}(\Upsilon_{Z_j^r, T_j, K_j}^{(C_n)} || Q_Z^{\otimes r} Q_{T_j} Q_{K_j})] = \mathbb{E}_{\mathcal{C}_n} \left[\sum_{z_j^r, t_j, k_j} \Upsilon^{(C_n)}(z_j^r, t_j, k_j) \log \left(\frac{\Upsilon^{(C_n)}(z_j^r, t_j, k_j)}{Q_Z^{\otimes r}(z_j^r) \times Q_{T_j}(t_j) \times Q_{K_j}(k_j)} \right) \right] \\
& = \mathbb{E}_{\mathcal{C}_n} \left[\sum_{z_j^r, t_j, k_j} \sum_{k_{j-2}} \sum_{t_{j-1}} \sum_{m_j} \sum_{s_j^r} \frac{1}{2^{r(R_k+R_t+R)}} \times Q_S^{\otimes r}(s_j^r) \right. \\
& \times W_{Z|U,S}^{\otimes r}(z_j^r | u^r(k_{j-2}, t_{j-1}, m_j), s_j^r) \times \mathbb{1}_{\{\sigma(s_j^r)=t_j\}} \times \mathbb{1}_{\{\Phi(s_j^r)=k_j\}} \\
& \times \log \left(\frac{\sum_{\tilde{k}_{j-2}} \sum_{\tilde{t}_{j-1}} \sum_{\tilde{m}_j} \sum_{\tilde{s}_j^r} Q_S^{\otimes r}(\tilde{s}_j^r) \times W_{Z|U,S}^{\otimes r}(z_j^r | u^r(\tilde{k}_{j-2}, \tilde{t}_{j-1}, \tilde{m}_j), \tilde{s}_j^r) \times \mathbb{1}_{\{\sigma(\tilde{s}_j^r)=\tilde{t}_j\}} \times \mathbb{1}_{\{\Phi(\tilde{s}_j^r)=k_j\}}}{2^{r(R_k+R_t+R-R_T-R_K)} \times Q_Z^{\otimes r}(z_j^r)} \right) \left. \right] \\
& \stackrel{(a)}{\leq} \sum_{z_j^r, t_j, k_j} \sum_{k_{j-2}} \sum_{t_{j-1}} \sum_{m_j} \frac{1}{2^{r(R_k+R_t+R)}} \sum_{s_j^r} \sum_{u^r(k_{j-2}, t_{j-1}, m_j)} \Upsilon_{S_j^r, Z_j^r, U^r}^{(C_n)}(s_j^r, z_j^r, u^r(k_{j-2}, t_{j-1}, m_j)) \\
& \times \mathbb{E}_{\sigma(s_j^r)} [\mathbb{1}_{\{\sigma(s_j^r)=t_j\}}] \times \mathbb{E}_{\Phi(s_j^r)} [\mathbb{1}_{\{\Phi(s_j^r)=k_j\}}] \\
& \times \log \mathbb{E}_{\setminus((k_{j-2}, t_{j-1}, m_j), \sigma(s_j^r), \Phi(s_j^r))} \left[\frac{1}{2^{r(R_k+R_t+R-R_T-R_K)} \times Q_Z^{\otimes r}(z_j^r)} \right. \\
& \times \left. \sum_{\tilde{k}_{j-2}} \sum_{\tilde{t}_{j-1}} \sum_{\tilde{m}_j} \sum_{\tilde{s}_j^r} Q_S^{\otimes r}(\tilde{s}_j^r) \times W_{Z|U,S}^{\otimes r}(z_j^r | u^r(\tilde{k}_{j-2}, \tilde{t}_{j-1}, \tilde{m}_j), \tilde{s}_j^r) \times \mathbb{1}_{\{\sigma(\tilde{s}_j^r)=\tilde{t}_j\}} \times \mathbb{1}_{\{\Phi(\tilde{s}_j^r)=k_j\}} \right] \\
& \stackrel{(b)}{\leq} \sum_{z_j^r, t_j, k_j} \sum_{k_{j-2}} \sum_{t_{j-1}} \sum_{m_j} \frac{1}{2^{r(R_k+R_t+R)}} \sum_{s_j^r} \sum_{u^r(k_{j-2}, t_{j-1}, m_j)} \Upsilon_{S_j^r, Z_j^r, U^r}^{(C_n)}(s_j^r, z_j^r, u^r(k_{j-2}, t_{j-1}, m_j)) \times \frac{1}{2^{rR_T}} \times \frac{1}{2^{rR_K}} \\
& \times \log \left(\frac{Q_S^{\otimes r}(s_j^r) \times W_{Z|U,S}^{\otimes r}(z_j^r | u^r(k_{j-2}, t_{j-1}, m_j), s_j^r)}{2^{r(R_k+R_t+R-R_T-R_K)} \times Q_Z^{\otimes r}(z_j^r)} \right) \\
& + \mathbb{E}_{\setminus(k_{j-2}, t_{j-1}, m_j)} \left[\frac{1}{2^{r(R_k+R_t+R-R_T-R_K)} \times Q_Z^{\otimes r}(z_j^r)} \right. \\
& \times \left. \sum_{(\tilde{k}_{j-2}, \tilde{t}_{j-1}, \tilde{m}_j) \neq (k_{j-2}, t_{j-1}, m_j)} Q_S^{\otimes r}(s_j^r) \times W_{Z|U,S}^{\otimes r}(z_j^r | u^r(\tilde{k}_{j-2}, \tilde{t}_{j-1}, \tilde{m}_j), s_j^r) \times \mathbb{1}_{\{\sigma(s_j^r)=\tilde{t}_j\}} \times \mathbb{1}_{\{\Phi(s_j^r)=\tilde{k}_j\}} \right] \\
& + \mathbb{E}_{\setminus(\Phi(s_j^r), \sigma(s_j^r))} \left[\frac{\sum_{\tilde{s}_j^r \neq s_j^r} Q_S^{\otimes r}(\tilde{s}_j^r) \times W_{Z|U,S}^{\otimes r}(z_j^r | u^r(k_{j-2}, t_{j-1}, m_j), \tilde{s}_j^r) \times \mathbb{1}_{\{\sigma(\tilde{s}_j^r)=t_j\}} \times \mathbb{1}_{\{\Phi(\tilde{s}_j^r)=k_j\}}}{2^{r(R_k+R_t+R-R_T-R_K)} \times Q_Z^{\otimes r}(z_j^r)} \right] + 1 \Big) \\
& \stackrel{(c)}{\leq} \sum_{z_j^r, t_j, k_j} \sum_{k_{j-2}} \sum_{t_{j-1}} \sum_{m_j} \frac{1}{2^{r(R_k+R_t+R)}} \sum_{s_j^r} \sum_{u^r(k_{j-2}, t_{j-1}, m_j)} \Upsilon_{S_j^r, Z_j^r, U^r}^{(C_n)}(s_j^r, z_j^r, u^r(k_{j-2}, t_{j-1}, m_j)) \times \frac{1}{2^{rR_T}} \times \frac{1}{2^{rR_K}} \\
& \times \log \left(\frac{Q_S^{\otimes r}(s_j^r) \times W_{Z|U,S}^{\otimes r}(z_j^r | u^r(k_{j-2}, t_{j-1}, m_j), s_j^r)}{2^{r(R_k+R_t+R-R_T-R_K)} \times Q_Z^{\otimes r}(z_j^r)} \right) \\
& + \sum_{(\tilde{k}_{j-2}, \tilde{t}_{j-1}, \tilde{m}_j) \neq (k_{j-2}, t_{j-1}, m_j)} \frac{Q_{S,Z}^{\otimes r}(s_j^r, z_j^r)}{2^{r(R_k+R_t+R-R_T-R_K)} \times Q_Z^{\otimes r}(z_j^r)} \\
& + \sum_{\tilde{s}_j^r \neq s_j^r} \left(\frac{Q_S^{\otimes r}(\tilde{s}_j^r) \times W_{Z|U,S}^{\otimes r}(z_j^r | u^r(k_{j-2}, t_{j-1}, m_j), \tilde{s}_j^r)}{2^{r(R_k+R_t+R)} \times Q_Z^{\otimes r}(z_j^r)} + 1 \right) \\
& \triangleq \Psi_1 + \Psi_2, \tag{230}
\end{aligned}$$

where (a) follows from Jensen's inequality, (b) and (c) hold because $\mathbb{1}_{\{\Phi(s_j^r)=k_j\}} \leq 1$. We defined Ψ_1 and Ψ_2 as

$$\begin{aligned}
\Psi_1 &= \sum_{t_j, k_j} \sum_{k_{j-2}} \sum_{t_{j-1}} \sum_{m_j} \frac{1}{2^{r(R_k+R_t+R+R_T+R_K)}} \sum_{(s_j^r, z_j^r, u^r(k_{j-2}, t_{j-1}, m_j)) \in T_\epsilon^{(n)}} \Upsilon_{S^r, Z^r, U^r}^{(C_n)}(s_j^r, z_j^r, u^r(k_{j-2}, t_{j-1}, m_j)) \\
&\quad \times \log \left(\frac{Q_S^{\otimes r}(s_j^r) \times W_{Z|U, S}^{\otimes r}(z_j^r | u^r(k_{j-2}, t_{j-1}, m_j), s_j^r)}{2^{r(R_k+R_t+R-R_T-R_K)} \times Q_Z^{\otimes r}(z_j^r)} \right. \\
&\quad + \sum_{(\tilde{k}_{j-2}, \tilde{t}_{j-1}, \tilde{m}_j) \neq (k_{j-2}, t_{j-1}, m_j)} \frac{Q_{S, Z}^{\otimes r}(s_j^r, z_j^r)}{2^{r(R_k+R_t+R-R_T-R_K)} \times Q_Z^{\otimes r}(z_j^r)} \\
&\quad \left. + \sum_{\tilde{s}_j^r \neq s_j^r} \frac{Q_S^{\otimes r}(\tilde{s}_j^r) \times W_{Z|U, S}^{\otimes r}(z_j^r | u^r(k_{j-2}, t_{j-1}, m_j), \tilde{s}_j^r)}{2^{r(R_k+R_t+R)} \times Q_Z^{\otimes r}(z_j^r)} + 1 \right) \\
&\leq \sum_{t_j, k_j} \sum_{k_{j-2}} \sum_{t_{j-1}} \sum_{m_j} \frac{1}{2^{r(R_k+R_t+R+R_T+R_K)}} \sum_{(s_j^r, z_j^r, u^r(k_{j-2}, t_{j-1}, m_j)) \in T_\epsilon^{(n)}} \Upsilon_{S^r, Z^r, U^r}^{(C_n)}(s_j^r, z_j^r, u^r(k_{j-2}, t_{j-1}, m_j)) \\
&\quad \times \log \left(\frac{Q_S^{\otimes r}(s_j^r) \times W_{Z|U, S}^{\otimes r}(z_j^r | u^r(k_{j-2}, t_{j-1}, m_j), s_j^r)}{2^{r(R_k+R_t+R-R_T-R_K)} \times Q_Z^{\otimes r}(z_j^r)} + \frac{2^{r(R_T+R_K)} \times Q_{S, Z}^{\otimes r}(s_j^r, z_j^r)}{Q_Z^{\otimes r}(z_j^r)} \right. \\
&\quad \left. + \frac{W_{Z|U}^{\otimes r}(z_j^r | u^r(k_{j-2}, t_{j-1}, m_j))}{2^{r(R_k+R_t+R)} \times Q_Z^{\otimes r}(z_j^r)} + 1 \right) \\
&\leq \log \left(\frac{2^{r(R_T+R_K)} 2^{-r(1-\epsilon)\mathbb{H}(S, Z|U)}}{2^{r(R_k+R_t+R)} 2^{-r(1+\epsilon)\mathbb{H}(Z)}} + \frac{2^{r(R_T+R_K)} 2^{-r(1-\epsilon)\mathbb{H}(S, Z)}}{2^{-r(1+\epsilon)\mathbb{H}(Z)}} + \frac{2^{-r(1-\epsilon)\mathbb{H}(Z|U)}}{2^{r(R_k+R_t+R)} 2^{-r(1+\epsilon)\mathbb{H}(Z)}} + 1 \right) \quad (231)
\end{aligned}$$

$$\begin{aligned}
\Psi_2 &= \sum_{t_j, k_j} \sum_{k_{j-2}} \sum_{t_{j-1}} \sum_{m_j} \frac{1}{2^{r(R_k+R_t+R+R_T+R_K)}} \sum_{(s_j^r, z_j^r, u^r(k_{j-2}, t_{j-1}, m_j)) \notin T_\epsilon^{(n)}} \Upsilon_{S^r, Z^r, U^r}^{(C_n)}(s_j^r, z_j^r, u^r(k_{j-2}, t_{j-1}, m_j)) \\
&\quad \times \log \left(\frac{Q_S^{\otimes r}(s_j^r) \times W_{Z|U, S}^{\otimes r}(z_j^r | u^r(k_{j-2}, t_{j-1}, m_j), s_j^r)}{2^{r(R_k+R_t+R-R_T-R_K)} \times Q_Z^{\otimes r}(z_j^r)} \right. \\
&\quad + \sum_{(\tilde{k}_{j-2}, \tilde{t}_{j-1}, \tilde{m}_j) \neq (k_{j-2}, t_{j-1}, m_j)} \frac{Q_{S, Z}^{\otimes r}(s_j^r, z_j^r)}{2^{r(R_k+R_t+R-R_T-R_K)} \times Q_Z^{\otimes r}(z_j^r)} \\
&\quad \left. + \sum_{\tilde{s}_j^r \neq s_j^r} \frac{Q_S^{\otimes r}(\tilde{s}_j^r) \times W_{Z|U, S}^{\otimes r}(z_j^r | u^r(k_{j-2}, t_{j-1}, m_j), \tilde{s}_j^r)}{2^{r(R_k+R_t+R)} \times Q_Z^{\otimes r}(z_j^r)} + 1 \right) \\
&\leq \sum_{t_j, k_j} \sum_{k_{j-2}} \sum_{t_{j-1}} \sum_{m_j} \frac{1}{2^{r(R_k+R_t+R+R_T+R_K)}} \sum_{(s_j^r, z_j^r, u^r(k_{j-2}, t_{j-1}, m_j)) \notin T_\epsilon^{(n)}} \Upsilon_{S^r, Z^r, U^r}^{(C_n)}(s_j^r, z_j^r, u^r(k_{j-2}, t_{j-1}, m_j)) \\
&\quad \times \log \left(\frac{Q_S^{\otimes r}(s_j^r) \times W_{Z|U, S}^{\otimes r}(z_j^r | u^r(k_{j-2}, t_{j-1}, m_j), s_j^r)}{2^{r(R_k+R_t+R-R_T-R_K)} \times Q_Z^{\otimes r}(z_j^r)} + \frac{2^{r(R_T+R_K)} \times Q_{S, Z}^{\otimes r}(s_j^r, z_j^r)}{Q_Z^{\otimes r}(z_j^r)} \right. \\
&\quad \left. + \frac{W_{Z|U}^{\otimes r}(z_j^r | u^r(k_{j-2}, t_{j-1}, m_j))}{2^{r(R_k+R_t+R)} \times Q_Z^{\otimes r}(z_j^r)} + 1 \right) \\
&\leq 2|S||Z||U|e^{-r\epsilon\mu_{S, Z, U}} \log \left(\frac{3}{\mu_Z} + 1 \right). \quad (232)
\end{aligned}$$

In (232) $\mu_{U, S, Z} = \min_{(u, s, z) \in (U, S, Z)} \Upsilon_{U, S, Z}(u, s, z)$ and $\mu_Z = \min_{z \in Z} \Upsilon_Z(z)$. When $r \rightarrow \infty$ then $\Psi_2 \rightarrow 0$ and if we choose $R_T + R_K = \mathbb{H}(S|Z) - \epsilon$, Ψ_1 goes to zero when r grows if

$$R_k + R_t + R > \mathbb{I}(U; S, Z), \quad (233)$$

$$R_k + R_t + R > \mathbb{I}(U; Z) \quad (234)$$

where (234) is redundant because of (233).

Decoding and Error Probability Analysis: By following the same steps as in [6], the probability of error vanishes when n grows if

$$R_t + R < \mathbb{I}(U; Y). \quad (235)$$

Input Cost Analysis: The proof follows similar lines to [6, Sec V].

By applying Fourier-Motzkin to (160), (233), and (235) and remarking that the scheme requires $R_t + R_k \leq R_T + R_K$ the following region will be derived

$$R \leq \mathbb{I}(U; Y) - \mathbb{H}(S|U, Y), \quad (236)$$

$$R \geq \mathbb{I}(U; S, Z) - \mathbb{H}(S|Z). \quad (237)$$

One can easily check that if (236) and (237) hold the region in Theorem 7 is also hold. The region in Theorem 7 also results to (236) and (237) because if (32) holds we can find a rate R which satisfies both (236) and (237).

APPENDIX H

PROOF OF THEOREM 9

We adopt a block-Markov encoding scheme in which $B-1$ independent messages are transmitted over B channel blocks each of length r , such that $n = rB$. The warden's observation is $Z^n = (Z_1^r, \dots, Z_B^r)$, the target output distribution is $Q_Z^{\otimes n}$, and Equation (63), describing the distance between the two distributions, continues to hold. The random code generation is as follows:

Fix $P_X(x)$, $P_{S,X,Y,Z}(s, x, y, z) = Q_S(s)P_{V|S}(v|s)P_X(x)W_{Y,Z|X,S}(y, z|x, s)$, and $\epsilon_1 > \epsilon_2 > 0$ such that, $Q_Z = Q_0$ and $\mathbb{E}[g(X)] \leq \frac{G}{1+\epsilon_2}$.

Codebook Generation for Keys: Let $P_V(v) = \sum_s Q_S(s)P_{V|S}(v|s)$. For each block $j \in \llbracket 1, B \rrbracket$, randomly and independently generate $2^{r\tilde{R}}$ sequences $v^r(\ell_j), \ell_j \in \llbracket 1, 2^{r\tilde{R}} \rrbracket$, each according to $\prod_{i=1}^r P_V(v_i)$. Partition the set of indices $\ell_j \in \llbracket 1, 2^{r\tilde{R}} \rrbracket$ into bins $\mathcal{B}(t)$, $t \in \llbracket 1, 2^{rR_T} \rrbracket$ by using function $\varphi : V^r(\ell_j) \rightarrow \llbracket 1, 2^{rR_T} \rrbracket$ through random binning by choosing the value of $\varphi(V^r(\ell_j))$ independently and uniformly at random for every $V^r(\ell_j) \in \mathcal{V}^r$.

For each block $j \in \llbracket 1, B \rrbracket$, create a function $\Phi : V^r(\ell_j) \rightarrow \llbracket 1, 2^{rR_K} \rrbracket$ through random binning by choosing the value of $\Phi(V^r(\ell_j))$ independently and uniformly at random for every $V^r(\ell_j) \in \mathcal{V}^r$. The key $k_j = \Phi(V^r(\ell_j))$ obtained in block $j \in \llbracket 1, B \rrbracket$ from the description of the channel state sequence $V^r(\ell_j)$ is used to assist the encoder in block $j+2$.

Codebook Generation for Messages: For each block $j \in \llbracket 1, B \rrbracket$ and for each $m_j \in \llbracket 1, 2^{rR} \rrbracket$, $t_{j-1} \in \llbracket 1, 2^{r\tilde{R}} \rrbracket$, and $k_{j-2} \in \llbracket 1, 2^{rR_k} \rrbracket$, randomly and independently generate a sequence $x^r(m_j, t_{j-1}, k_{j-2})$ according to $\prod_{i=1}^r p(x_i)$. These constitute the codebook \mathcal{C}_n . The indices (m_j, t_{j-1}, k_{j-2}) can be viewed as a two layer binning. We define an ideal PMF for codebook \mathcal{C}_n , as an approximate distribution to facilitate the analysis

$$\begin{aligned} \Gamma_{M_j, T_{j-1}, K_{j-2}, L_j, X^r, V_j^r, S_j^r, Z_j^r, K_{j-1}, K_j, T_j}^{(\mathcal{C}_n)}(m_j, t_{j-1}, k_{j-2}, \ell_j, \tilde{x}^r, \tilde{v}^r, s_j^r, z_j^r, k_{j-1}, k_j, t_j) = \\ 2^{-r(R+R_t+R_k+\tilde{R})} \times \mathbb{1}_{\{x^r(m_j, t_{j-1}, k_{j-2}) = \tilde{x}^r\}} \times \mathbb{1}_{\{v^r(\ell_j) = \tilde{v}^r\}} \times P_{S|V}^{\otimes r}(s_j^r | \tilde{v}^r) \times W_{Z|X,S}^{\otimes r}(z_j^r | \tilde{x}^r, s_j^r) \\ \times 2^{-rR_k} \times \mathbb{1}_{\{\varphi(\tilde{v}^r) = t_j\}} \times \mathbb{1}_{\{\Phi(\tilde{v}^r) = k_j\}}, \end{aligned} \quad (238)$$

where $W_{Z|X,S}$ is the marginal distribution of $W_{Y,Z|X,S}$ defined in Theorem (9).

Encoding: In the first block, the Encoder chooses the indices (m_1, t_0, k_{-1}) uniformly at random and then, based on these indices transmits codeword $x^r(m_1, t_0, k_{-1})$.

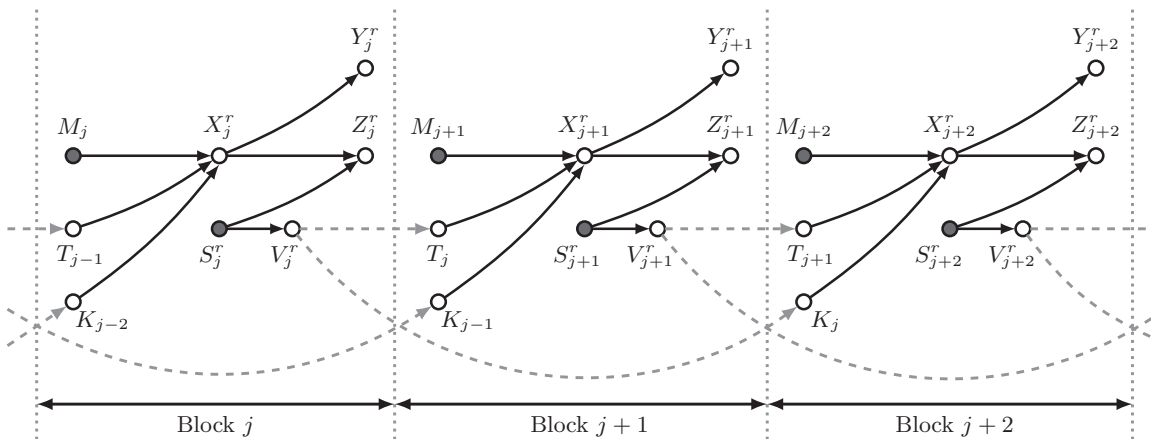

Fig. 12. Functional dependence graph for the block-Markov encoding scheme

In the second block, the encoder chooses the indices (m_2, k_0) uniformly at random. At the beginning of this block the transmitter knows the CSI of the first block therefore to generate a secret key shared between the transmitter and the receiver, chooses the index ℓ_1 according to distribution with $j = 1$,

$$f(\ell_j | s_j^r) = \frac{P_{S|V}^{\otimes r}(s_j^r | v^r(\ell_j))}{\sum_{\ell' \in [1, 2^{r\bar{R}}]} P_{S|V}^{\otimes r}(s_j^r | v^r(\ell'))}, \quad (239)$$

where $P_{S|V}^{\otimes r}$ is defined from the ideal PMF in (238). Then generates the reconciliation index $t_1 = \varphi(v^n(\ell_1))$; simultaneously the transmitter generates a key $k_1 = \Phi(v^n(\ell_1))$ from the description of its CSI of the first block $v^r(\ell_1)$ to be used in the next block. Base on these indices the encoder transmits codeword $x^r(m_2, t_1, k_0)$.

In block $j \in [3, B]$, the encoder first selects the index ℓ_{j-1} based s_{j-1}^r by using the likelihood encoder described in (239) and then generates the reconciliation index $t_{j-1} = \varphi(v^n(\ell_{j-1}))$; simultaneously the transmitter generates a key $k_{j-1} = \Phi(v^n(\ell_{j-1}))$ from the description of its CSI of the block $j-1$, $v^r(\ell_{j-1})$, to be used in the next block. Then to send message m_j and reconciliation index t_{j-1} according to the generated key k_{j-2} from the previous block, the encoder transmits codeword $x^r(m_j, t_{j-1}, k_{j-2})$.

Define

$$\begin{aligned} & \Upsilon_{M_j, T_{j-1}, K_{j-2}, X^r, S_j^r, L_j, V_j^r, Z_j^r, K_{j-1}, K_j, T_j}^{(C_n)}(m_j, t_{j-1}, k_{j-2}, \tilde{x}^r, s_j^r, \ell_j, v_j^r, z_j^r, k_{j-1}, k_j, t_j) \triangleq 2^{-r(R+R_t+R_k)} \\ & \times \mathbb{1}_{\{x^r(m_j, t_{j-1}, k_{j-2}) = \tilde{x}^r\}} \times Q_{S^r}^{\otimes r}(s_j^r) \times f(\ell_j | s_j^r) \times \mathbb{1}_{\{v^r(\ell_j) = \tilde{v}^r\}} \\ & \times W_{Z|X, S}^{\otimes r}(z_j^r | \tilde{x}^r, s_j^r) \times 2^{-rR_k} \times \mathbb{1}_{\{\sigma(v_j^r) = t_j\}} \times \mathbb{1}_{\{\Phi(v_j^r) = k_j\}}. \end{aligned} \quad (240)$$

For a fixed codebook \mathcal{C}_n , the induced joint distribution over the codebook (i.e. $P^{(C_n)}$) satisfies

$$\|P_{M_j, T_{j-1}, K_{j-2}, X^r, S_j^r, L_j, V_j^r, Z_j^r, K_{j-1}, K_j, T_j}^{(C_n)} - \Upsilon_{M_j, T_{j-1}, K_{j-2}, X^r, S_j^r, L_j, V_j^r, Z_j^r, K_{j-1}, K_j, T_j}^{(C_n)}\|_1 \leq \epsilon. \quad (241)$$

This intermediate distribution $\Upsilon^{(C_n)}$ approximates the true distribution $P^{(C_n)}$ and will be used in the sequel for bounding purposes. Expression (241) holds because the main difference in $\Upsilon^{(C_n)}$ is assuming the keys K_{j-2} , K_{j-1} and the reconciliation index T_{j-1} are uniformly distributed, which is made (arbitrarily) nearly uniform in $P^{(C_n)}$ with appropriate control of rate.

Covert Analysis: We now show that this coding scheme guarantees that $\mathbb{E}_{\mathcal{C}_n}[\mathbb{D}(P_{Z^n}^{(\mathcal{C}_n)}||Q_Z^{\otimes n})] \xrightarrow{n \rightarrow \infty} 0$. Similar to (123) by using functional dependence graph depicted in Fig. 12 it can be shown that

$$\mathbb{D}(P_{Z^n}^{(\mathcal{C}_n)}||Q_Z^{\otimes n}) \leq 2 \sum_{j=1}^B \mathbb{D}(P_{Z_j^r, K_{j-1}, K_j, T_j}^{(\mathcal{C}_n)}||Q_Z^{\otimes r} Q_{K_{j-1}} Q_{K_j} Q_{T_j}). \quad (242)$$

By using the triangle inequality

$$\begin{aligned} & \mathbb{E}_{\mathcal{C}_n} \|P_{Z_j^r, K_{j-1}, K_j, T_j}^{(\mathcal{C}_n)} - Q_Z^{\otimes r} Q_{K_{j-1}} Q_{K_j} Q_{T_j}\|_1 \leq \\ & \mathbb{E}_{\mathcal{C}_n} \|P_{Z_j^r, K_{j-1}, K_j, T_j}^{(\mathcal{C}_n)} - \Gamma_{Z_j^r, K_{j-1}, K_j, T_j}^{(\mathcal{C}_n)}\|_1 + \mathbb{E}_{\mathcal{C}_n} \|\Gamma_{Z_j^r, K_{j-1}, K_j, T_j}^{(\mathcal{C}_n)} - Q_Z^{\otimes r} Q_{K_{j-1}} Q_{K_j} Q_{T_j}\|_1 \\ & \leq \mathbb{E}_{\mathcal{C}_n} \|P_{Z_j^r, K_{j-1}, K_j, T_j}^{(\mathcal{C}_n)} - \Upsilon_{Z_j^r, K_{j-1}, K_j, T_j}^{(\mathcal{C}_n)}\|_1 + \mathbb{E}_{\mathcal{C}_n} \|\Upsilon_{Z_j^r, K_{j-1}, K_j, T_j}^{(\mathcal{C}_n)} - \Gamma_{Z_j^r, K_{j-1}, K_j, T_j}^{(\mathcal{C}_n)}\|_1 \\ & \quad + \mathbb{E}_{\mathcal{C}_n} \|\Gamma_{Z_j^r, K_{j-1}, K_j, T_j}^{(\mathcal{C}_n)} - Q_Z^{\otimes r} Q_{K_{j-1}} Q_{K_j} Q_{T_j}\|_1. \end{aligned} \quad (243)$$

From (241) the first term on the RHS of (243) goes to zero when n grows. To bound the second term on the RHS of (243)

$$\Gamma_{M_j, T_{j-1}, K_{j-2}}^{(\mathcal{C}_n)} = 2^{-r(R+R_t+R_k)} = P_{M_j, T_{j-1}, K_{j-2}}^{(\mathcal{C}_n)}, \quad (244)$$

$$\Gamma_{X^r|M_j, T_{j-1}, K_{j-2}, S_j^r}^{(\mathcal{C}_n)} = \mathbf{1}_{\{x^r(m_j, t_{j-1}, k_{j-2}) = \tilde{x}^r\}} = \Upsilon_{X^r|M_j, T_{j-1}, K_{j-2}, S_j^r}^{(\mathcal{C}_n)}, \quad (245)$$

$$\Gamma_{L_j|M_j, T_{j-1}, K_{j-2}, S_j^r, X^r}^{(\mathcal{C}_n)} = f(\ell_j|s_j^r) = \Upsilon_{L_j|M_j, T_{j-1}, K_{j-2}, S_j^r, X^r}^{(\mathcal{C}_n)}, \quad (246)$$

$$\Gamma_{V^r|M_j, T_{j-1}, K_{j-2}, S_j^r, L_j, X^r}^{(\mathcal{C}_n)} = \mathbf{1}_{\{v^r(\ell_j) = \tilde{v}^r\}} = \Upsilon_{V^r|M_j, T_{j-1}, K_{j-2}, S_j^r, L_j, X^r}^{(\mathcal{C}_n)}, \quad (247)$$

$$\Gamma_{Z_j^r|M_j, T_{j-1}, K_{j-2}, S_j^r, L_j, X^r, V_j^r}^{(\mathcal{C}_n)} = W_{Z|X, S}^{\otimes r} = \Upsilon_{Z_j^r|M_j, T_{j-1}, K_{j-2}, S_j^r, L_j, X^r, V_j^r}^{(\mathcal{C}_n)}, \quad (248)$$

$$\Gamma_{K_{j-1}|M_j, T_{j-1}, K_{j-2}, S_j^r, L_j, X^r, V_j^r, Z_j^r}^{(\mathcal{C}_n)} = 2^{-rR_k} = \Upsilon_{K_{j-1}|M_j, T_{j-1}, K_{j-2}, S_j^r, L_j, X^r, V_j^r, Z_j^r}^{(\mathcal{C}_n)}, \quad (249)$$

$$\Gamma_{T_j|M_j, T_{j-1}, K_{j-2}, S_j^r, L_j, X^r, V_j^r, Z_j^r}^{(\mathcal{C}_n)} = \mathbf{1}_{\{\sigma(v_j^r) = t_j\}} = \Upsilon_{T_j|M_j, T_{j-1}, K_{j-2}, S_j^r, L_j, X^r, V_j^r, Z_j^r}^{(\mathcal{C}_n)}, \quad (250)$$

$$\Gamma_{K_j|M_j, T_{j-1}, K_{j-2}, S_j^r, L_j, X^r, V_j^r, Z_j^r, T_j}^{(\mathcal{C}_n)} = \mathbf{1}_{\{\Phi(v_j^r) = k_j\}} = \Upsilon_{K_j|M_j, T_{j-1}, K_{j-2}, S_j^r, L_j, X^r, V_j^r, Z_j^r, T_j}^{(\mathcal{C}_n)}, \quad (251)$$

where (246) follows from (239). Hence,

$$\begin{aligned} & \mathbb{E}_{\mathcal{C}_n} \|\Upsilon_{Z_j^r, K_{j-1}, K_j, T_j}^{(\mathcal{C}_n)} - \Gamma_{Z_j^r, K_{j-1}, K_j, T_j}^{(\mathcal{C}_n)}\|_1 \\ & \leq \mathbb{E}_{\mathcal{C}_n} \|\Upsilon_{M_j, T_{j-1}, K_{j-2}, S_j^r, L_j, X^r, V_j^r, Z_j^r, K_{j-1}, T_j, K_j}^{(\mathcal{C}_n)} - \Gamma_{M_j, T_{j-1}, K_{j-2}, S_j^r, L_j, X^r, V_j^r, Z_j^r, K_{j-1}, T_j, K_j}^{(\mathcal{C}_n)}\|_1 \\ & \stackrel{(a)}{=} \mathbb{E}_{\mathcal{C}_n} \|\Upsilon_{M_j, T_{j-1}, K_{j-2}, S_j^r}^{(\mathcal{C}_n)} - \Gamma_{M_j, T_{j-1}, K_{j-2}, S_j^r}^{(\mathcal{C}_n)}\|_1 \\ & \stackrel{(b)}{=} \mathbb{E}_{\mathcal{C}_n} \|Q_S^{\otimes r} - \Gamma_{S_j^r|M_j=1, T_{j-1}=1, K_{j-2}=1}^{(\mathcal{C}_n)}\|_1, \end{aligned} \quad (252)$$

where (a) follows from (245)-(251) and (b) follows from the symmetry of the codebook construction with respect to M_j , T_{j-1} , and K_{j-2} and (244). Based on the soft covering lemma [28, Corollary VII.5] the RHS of (252) vanishes if

$$\tilde{R} > \mathbb{I}(S; V). \quad (253)$$

We now proceed to bound the third term on the RHS of (243). First, consider the marginal

$$\begin{aligned} & \Gamma_{Z_j^r, K_{j-1}, K_j, T_j}^{(\mathcal{C}_n)}(z_j^r, k_{j-1}, k_j, t_j) = \sum_{m_j} \sum_{t_{j-1}} \sum_{k_{j-2}} \sum_{\ell_j} \sum_{s_j^r} \frac{1}{2^{r(R+R_t+R_k+\tilde{R})}} \times P_{S|V}^{\otimes r}(s_j^r|v_j^r(\ell_j)) \\ & \quad \times W_{Z|X, S}^{\otimes r}(z_j^r|x^r(m_j, t_{j-1}, k_{j-2}), s_j^r) \times 2^{-rR_k} \times \mathbf{1}_{\{\Phi(v_j^r(\ell_j)) = k_j\}} \times \mathbf{1}_{\{\sigma(v_j^r(\ell_j)) = t_j\}}. \end{aligned} \quad (254)$$

We now have

$$\begin{aligned}
& \mathbb{E}_{\mathcal{C}_n} [\mathbb{D}(\Gamma_{Z_j^r, K_{j-1}, K_j, T_j}^{(C_n)} \| Q_Z^{\otimes r} Q_{K_{j-1}} Q_{T_j} Q_{K_j})] \\
&= \mathbb{E}_{\mathcal{C}_n} \left[\sum_{z_j^r, k_{j-1}, k_j, t_j} \Gamma^{(C_n)}(z_j^r, k_{j-1}, k_j, t_j) \log \left(\frac{\Gamma^{(C_n)}(z_j^r, k_{j-1}, k_j, t_j)}{Q_Z^{\otimes r}(z_j^r) \times Q_{K_{j-1}}(k_{j-1}) \times Q_{T_j}(t_j) \times Q_{K_j}(k_j)} \right) \right] \\
&= \mathbb{E}_{\mathcal{C}_n} \left[\sum_{z_j^r, k_{j-1}, k_j, t_j} \sum_{m_j} \sum_{t_{j-1}} \sum_{k_{j-2}} \sum_{\ell_j} \sum_{s_j^r} \frac{1}{2^{r(R+R_t+2R_k+\tilde{R})}} \times P_{S|V}^{\otimes r}(s_j^r | v_j^r(\ell_j)) \right. \\
&\times W_{Z|X,S}^{\otimes r}(z_j^r | x^r(m_j, t_{j-1}, k_{j-2}), s_j^r) \times \mathbb{1}_{\{\varphi(v_j^r(\ell_j))=t_j\}} \times \mathbb{1}_{\{\Phi(v_j^r(\ell_j))=k_j\}} \\
&\times \log \left(\frac{1}{2^{r(R+R_t+R_k+\tilde{R}-R_T-R_K)} \times Q_Z^{\otimes r}(z_j^r)} \right) \\
&\times \sum_{\tilde{m}_j} \sum_{\tilde{t}_{j-1}} \sum_{\tilde{k}_{j-2}} \sum_{\tilde{\ell}_j} \sum_{\tilde{s}_j^r} P_{S|V}^{\otimes r}(\tilde{s}_j^r | v_j^r(\tilde{\ell}_j)) \times W_{Z|X,S}^{\otimes r}(z_j^r | x^r(\tilde{m}_j, \tilde{t}_{j-1}, \tilde{k}_{j-2}), \tilde{s}_j^r) \\
&\times \mathbb{1}_{\{\varphi(v_j^r(\tilde{\ell}_j))=t_j\}} \times \mathbb{1}_{\{\Phi(v_j^r(\tilde{\ell}_j))=k_j\}} \left. \right] \\
&\stackrel{(a)}{\leq} \sum_{z_j^r, k_{j-1}, k_j, t_j} \sum_{m_j} \sum_{t_{j-1}} \sum_{k_{j-2}} \sum_{\ell_j} \frac{1}{2^{r(R+R_t+2R_k+\tilde{R})}} \sum_{x^r(m_j, t_{j-1}, k_{j-2}), s_j^r, v_j^r(\ell_j)} \Gamma_{X^r, S_j^r, V_j^r, Z_j^r}^{(C_n)}(x^r(m_j, t_{j-1}, k_{j-2}), s_j^r, v_j^r(\ell_j), z_j^r) \\
&\times \mathbb{E}_{\varphi(v_j^r(\ell_j))} [\mathbb{1}_{\{\varphi(v_j^r(\ell_j))=t_j\}}] \times \mathbb{E}_{\Phi(v_j^r(\ell_j))} [\mathbb{1}_{\{\Phi(v_j^r(\ell_j))=k_j\}}] \\
&\times \log \mathbb{E}_{\substack{\setminus(m_j, t_{j-1}, k_{j-2}, \ell_j), \\ \setminus(\varphi(v_j^r(\ell_j)), \Phi(v_j^r(\ell_j)))}} \left[\frac{1}{2^{r(R+R_t+R_k+\tilde{R}-R_T-R_K)} \times Q_Z^{\otimes r}(z_j^r)} \right. \\
&\times \sum_{\tilde{m}_j} \sum_{\tilde{t}_{j-1}} \sum_{\tilde{k}_{j-2}} \sum_{\tilde{\ell}_j} \sum_{\tilde{s}_j^r} P_{S|V}^{\otimes r}(\tilde{s}_j^r | v_j^r(\tilde{\ell}_j)) \times W_{Z|X,S}^{\otimes r}(z_j^r | x^r(\tilde{m}_j, \tilde{t}_{j-1}, \tilde{k}_{j-2}), \tilde{s}_j^r) \times \mathbb{1}_{\{\varphi(v_j^r(\tilde{\ell}_j))=t_j\}} \times \mathbb{1}_{\{\Phi(v_j^r(\tilde{\ell}_j))=k_j\}} \left. \right] \\
&\stackrel{(b)}{\leq} \sum_{z_j^r, k_{j-1}, k_j, t_j} \sum_{m_j} \sum_{t_{j-1}} \sum_{k_{j-2}} \sum_{\ell_j} \frac{1}{2^{r(R+R_t+2R_k+\tilde{R})}} \sum_{x^r(m_j, t_{j-1}, k_{j-2}), s_j^r, v_j^r(\ell_j)} \Gamma_{X^r, S_j^r, V_j^r, Z_j^r}^{(C_n)}(x^r(m_j, t_{j-1}, k_{j-2}), s_j^r, v_j^r(\ell_j), z_j^r) \\
&\times \frac{1}{2^{rR_T}} \times \frac{1}{2^{rR_K}} \times \log \left(\frac{P_{S|V}^{\otimes r}(s_j^r | v_j^r(\ell_j)) \times W_{Z|X,S}^{\otimes r}(z_j^r | x^r(m_j, t_{j-1}, k_{j-2}), s_j^r)}{2^{r(R+R_t+R_k+\tilde{R}-R_T-R_K)} \times Q_Z^{\otimes r}(z_j^r)} \right) \\
&+ \mathbb{E}_{\setminus(m_j, t_{j-1}, k_{j-2})} \left[\frac{\sum_{(\tilde{m}_j, \tilde{t}_{j-1}, \tilde{k}_{j-2}) \neq (m_j, t_{j-1}, k_{j-2})} P_{S|V}^{\otimes r}(s_j^r | v_j^r(\ell_j)) \times W_{Z|X,S}^{\otimes r}(z_j^r | x^r(\tilde{m}_j, \tilde{t}_{j-1}, \tilde{k}_{j-2}), s_j^r)}{2^{r(R+R_t+R_k+\tilde{R}-R_T-R_K)} \times Q_Z^{\otimes r}(z_j^r)} \right] \\
&+ \frac{\sum_{\tilde{s}_j^r \neq s_j^r} P_{S|V}^{\otimes r}(\tilde{s}_j^r | v_j^r(\ell_j)) \times W_{Z|X,S}^{\otimes r}(z_j^r | x^r(m_j, t_{j-1}, k_{j-2}), \tilde{s}_j^r)}{2^{r(R+R_t+R_k+\tilde{R}-R_T-R_K)} \times Q_Z^{\otimes r}(z_j^r)} \\
&+ \mathbb{E}_{\setminus \ell_j, \setminus(\varphi(v_j^r(\ell_j)), \Phi(v_j^r(\ell_j)))} \left[\frac{1}{2^{r(R+R_t+R_k+\tilde{R}-R_T-R_K)} \times Q_Z^{\otimes r}(z_j^r)} \right. \\
&\times \sum_{\tilde{s}_j^r \neq s_j^r} \sum_{\tilde{\ell}_j \neq \ell_j} P_{S|V}^{\otimes r}(\tilde{s}_j^r | v_j^r(\tilde{\ell}_j)) \times W_{Z|X,S}^{\otimes r}(z_j^r | x^r(m_j, t_{j-1}, k_{j-2}), \tilde{s}_j^r) \times \mathbb{1}_{\{\varphi(v_j^r(\tilde{\ell}_j))=t_j\}} \times \mathbb{1}_{\{\Phi(v_j^r(\tilde{\ell}_j))=k_j\}} \left. \right] \\
&+ \mathbb{E}_{\setminus(m_j, t_{j-1}, k_{j-2})} \left[\frac{\sum_{\tilde{s}_j^r \neq s_j^r} \sum_{(\tilde{m}_j, \tilde{t}_{j-1}, \tilde{k}_{j-2}) \neq (m_j, t_{j-1}, k_{j-2})} P_{S|V}^{\otimes r}(\tilde{s}_j^r | v_j^r(\ell_j)) \times W_{Z|X,S}^{\otimes r}(z_j^r | x^r(\tilde{m}_j, \tilde{t}_{j-1}, \tilde{k}_{j-2}), \tilde{s}_j^r)}{2^{r(R+R_t+R_k+\tilde{R}-R_T-R_K)} \times Q_Z^{\otimes r}(z_j^r)} \right]
\end{aligned}$$

$$\begin{aligned}
& + \mathbb{E}_{\substack{\setminus \ell_j, \\ \setminus (\varphi(v_j^r(\ell_j)), \Phi(v_j^r(\ell_j)))}} \left[\frac{1}{2^{r(R+R_t+R_k+\tilde{R}-R_T-R_K)} \times Q_Z^{\otimes r}(z_j^r)} \right. \\
& \times \sum_{\tilde{\ell}_j \neq \ell_j} P_{S|V}^{\otimes r}(s_j^r | v_j^r(\tilde{\ell}_j)) \times W_{Z|X,S}^{\otimes r}(z_j^r | x^r(m_j, t_{j-1}, k_{j-2}), s_j^r) \times \mathbb{1}_{\{\varphi(v_j^r(\tilde{\ell}_j))=t_j\}} \times \mathbb{1}_{\{\Phi(v_j^r(\tilde{\ell}_j))=k_j\}} \left. \right] \\
& + \mathbb{E}_{\substack{\setminus (m_j, t_{j-1}, k_{j-2}, \ell_j), \\ \setminus (\varphi(v_j^r(\ell_j)), \Phi(v_j^r(\ell_j)))}} \left[\frac{1}{2^{r(R+R_t+R_k+\tilde{R}-R_T-R_K)} \times Q_Z^{\otimes r}(z_j^r)} \right. \\
& \times \sum_{\tilde{s}_j^r} \sum_{\tilde{\ell}_j \neq \ell_j} \sum_{(\tilde{m}_j, \tilde{t}_{j-1}, \tilde{k}_{j-2}) \neq (m_j, t_{j-1}, k_{j-2})} P_{S|V}^{\otimes r}(\tilde{s}_j^r | v_j^r(\tilde{\ell}_j)) \times W_{Z|X,S}^{\otimes r}(z_j^r | x^r(\tilde{m}_j, \tilde{t}_{j-1}, \tilde{k}_{j-2}), \tilde{s}_j^r) \\
& \times \mathbb{1}_{\{\varphi(v_j^r(\tilde{\ell}_j))=t_j\}} \times \mathbb{1}_{\{\Phi(v_j^r(\tilde{\ell}_j))=k_j\}} \left. \right] \\
& \stackrel{(c)}{\leq} \sum_{z_j^r, k_{j-1}, k_j, t_j} \sum_{m_j} \sum_{t_{j-1}} \sum_{k_{j-2}} \sum_{\ell_j} \frac{1}{2^{r(R+R_t+2R_k+\tilde{R})}} \sum_{x^r(m_j, t_{j-1}, k_{j-2}), s_j^r, v_j^r(\ell_j)} \Gamma_{X^r, S_j^r, V_j^r, Z_j^r}^{(C_n)}(x^r(m_j, t_{j-1}, k_{j-2}), s_j^r, v_j^r(\ell_j), z_j^r) \\
& \times \frac{1}{2^{rR_T}} \times \frac{1}{2^{rR_K}} \times \log \left(\frac{P_{S|V}^{\otimes r}(s_j^r | v_j^r(\ell_j)) \times W_{Z|X,S}^{\otimes r}(z_j^r | x^r(m_j, t_{j-1}, k_{j-2}), s_j^r)}{2^{r(R+R_t+R_k+\tilde{R}-R_T-R_K)} \times Q_Z^{\otimes r}(z_j^r)} \right) \\
& + \frac{\sum_{(\tilde{m}_j, \tilde{t}_{j-1}, \tilde{k}_{j-2}) \neq (m_j, t_{j-1}, k_{j-2})} P_{S|V}^{\otimes r}(s_j^r | v_j^r(\ell_j)) \times W_{Z|S}^{\otimes r}(z_j^r | s_j^r)}{2^{r(R+R_t+R_k+\tilde{R}-R_T-R_K)} \times Q_Z^{\otimes r}(z_j^r)} \\
& + \frac{\sum_{\tilde{s}_j^r \neq s_j^r} P_{S|V}^{\otimes r}(\tilde{s}_j^r | v_j^r(\ell_j)) \times W_{Z|X,S}^{\otimes r}(z_j^r | x^r(m_j, t_{j-1}, k_{j-2}), \tilde{s}_j^r)}{2^{r(R+R_t+R_k+\tilde{R}-R_T-R_K)} \times Q_Z^{\otimes r}(z_j^r)} \\
& + \frac{\sum_{\tilde{s}_j^r \neq s_j^r} \sum_{\tilde{\ell}_j \neq \ell_j} Q_S^{\otimes r}(s_j^r) \times W_{Z|X,S}^{\otimes r}(z_j^r | x^r(m_j, t_{j-1}, k_{j-2}), \tilde{s}_j^r)}{2^{r(R+R_t+R_k+\tilde{R})} \times Q_Z^{\otimes r}(z_j^r)} \\
& + \frac{\sum_{\tilde{s}_j^r \neq s_j^r} \sum_{(\tilde{m}_j, \tilde{t}_{j-1}, \tilde{k}_{j-2}) \neq (m_j, t_{j-1}, k_{j-2})} P_{S|V}^{\otimes r}(\tilde{s}_j^r | v_j^r(\ell_j)) \times W_{Z|S}^{\otimes r}(z_j^r | \tilde{s}_j^r)}{2^{r(R+R_t+R_k+\tilde{R}-R_T-R_K)} \times Q_Z^{\otimes r}(z_j^r)} \\
& + \frac{\sum_{\tilde{\ell}_j \neq \ell_j} Q_S^{\otimes r}(s_j^r) \times W_{Z|X,S}^{\otimes r}(z_j^r | x^r(m_j, t_{j-1}, k_{j-2}), s_j^r)}{2^{r(R+R_t+R_k+\tilde{R})} \times Q_Z^{\otimes r}(z_j^r)} + 1 \Big) \\
& \triangleq \Psi_1 + \Psi_2, \tag{255}
\end{aligned}$$

where (a) follows from Jensen's inequality, (b) and (c) hold because $\mathbb{1}_{\{\Phi(s_j^r)=k_j\}} \leq 1$. We defined Ψ_1 and Ψ_2 as

$$\begin{aligned}
\Psi_1 &= \sum_{k_{j-1}, k_j, t_j} \sum_{m_j} \sum_{t_{j-1}} \sum_{k_{j-2}} \sum_{\ell_j} \frac{1}{2^{r(R+R_t+2R_k+R_T+R_K)}} \\
& \times \sum_{\substack{(s_j^r, v_j^r, x^r(m_j, t_{j-1}, k_{j-2}), z_j^r) \in T_\epsilon^{(n)}}} \Gamma_{S^r, V^r, X^r, Z^r}^{(C_n)}(s_j^r, v_j^r, x^r(m_j, t_{j-1}, k_{j-2}), z_j^r) \\
& \times \log \left(\frac{P_{S|V}^{\otimes r}(s_j^r | v_j^r(\ell_j)) \times W_{Z|X,S}^{\otimes r}(z_j^r | x^r(m_j, t_{j-1}, k_{j-2}), s_j^r)}{2^{r(R+R_t+R_k+\tilde{R}-R_T-R_K)} \times Q_Z^{\otimes r}(z_j^r)} \right) \\
& + \sum_{(\tilde{m}_j, \tilde{t}_{j-1}, \tilde{k}_{j-2}) \neq (m_j, t_{j-1}, k_{j-2})} \frac{P_{S|V}^{\otimes r}(s_j^r | v_j^r(\ell_j)) \times W_{Z|S}^{\otimes r}(z_j^r | s_j^r)}{2^{r(R+R_t+R_k+\tilde{R}-R_T-R_K)} \times Q_Z^{\otimes r}(z_j^r)}
\end{aligned}$$

$$\begin{aligned}
& + \frac{\sum_{\tilde{s}_j^r \neq s_j^r} P_{S|V}^{\otimes r}(\tilde{s}_j^r | v_j^r(\ell_j)) \times W_{Z|X,S}^{\otimes r}(z_j^r | x^r(m_j, t_{j-1}, k_{j-2}), \tilde{s}_j^r)}{2^{r(R+R_t+R_k+\tilde{R}-R_T-R_K)} \times Q_Z^{\otimes r}(z_j^r)} \\
& + \frac{\sum_{\tilde{s}_j^r \neq s_j^r} \sum_{\tilde{\ell}_j \neq \ell_j} Q_S^{\otimes r}(\tilde{s}_j^r) \times W_{Z|X,S}^{\otimes r}(z_j^r | x^r(m_j, t_{j-1}, k_{j-2}), \tilde{s}_j^r)}{2^{r(R+R_t+R_k+\tilde{R})} \times Q_Z^{\otimes r}(z_j^r)} \\
& + \frac{\sum_{\tilde{s}_j^r \neq s_j^r} \sum_{(\tilde{m}_j, \tilde{t}_{j-1}, \tilde{k}_{j-2}) \neq (m_j, t_{j-1}, k_{j-2})} P_{S|V}^{\otimes r}(\tilde{s}_j^r | v_j^r(\ell_j)) \times W_{Z|S}^{\otimes r}(z_j^r | \tilde{s}_j^r)}{2^{r(R+R_t+R_k+\tilde{R}-R_T-R_K)} \times Q_Z^{\otimes r}(z_j^r)} \\
& + \frac{\sum_{\tilde{\ell}_j \neq \ell_j} Q_S^{\otimes r}(s_j^r) \times W_{Z|X,S}^{\otimes r}(z_j^r | x^r(m_j, t_{j-1}, k_{j-2}), s_j^r)}{2^{r(R+R_t+R_k+\tilde{R})} \times Q_Z^{\otimes r}(z_j^r)} + 1 \Big) \\
\leq & \sum_{k_{j-1}, k_j, t_j} \sum_{m_j} \sum_{t_{j-1}} \sum_{k_{j-2}} \sum_{\ell_j} \frac{1}{2^{r(R+R_t+2R_k+R_T+R_K)}} \\
& \times \sum_{(s_j^r, v_j^r, x^r(m_j, t_{j-1}, k_{j-2}), z_j^r) \in T_\epsilon^{(n)}} \Gamma_{S^r, V^r, X^r, Z^r}^{(\mathcal{C}_n)}(s_j^r, v_j^r, x^r(m_j, t_{j-1}, k_{j-2}), z_j^r) \\
& \times \log \left(\frac{P_{S|V}^{\otimes r}(s_j^r | v_j^r(\ell_j)) \times W_{Z|X,S}^{\otimes r}(z_j^r | x^r(m_j, t_{j-1}, k_{j-2}), s_j^r)}{2^{r(R+R_t+R_k+\tilde{R}-R_T-R_K)} \times Q_Z^{\otimes r}(z_j^r)} + \frac{P_{S|V}^{\otimes r}(s_j^r | v_j^r(\ell_j)) \times W_{Z|S}^{\otimes r}(z_j^r | s_j^r)}{2^{r(\tilde{R}-R_T-R_K)} \times Q_Z^{\otimes r}(z_j^r)} \right. \\
& + \frac{W_{Z|X}^{\otimes r}(z_j^r | x^r(k_{j-2}, t_{j-1}, m_j))}{2^{r(R+R_t+R_k+\tilde{R}-R_T-R_K)} \times Q_Z^{\otimes r}(z_j^r)} + \frac{W_{Z|X}^{\otimes r}(z_j^r | x^r(k_{j-2}, t_{j-1}, m_j))}{2^{r(R+R_t+R_k)} \times Q_Z^{\otimes r}(z_j^r)} \\
& \left. + \frac{Q_Z^{\otimes r}(z_j^r)}{2^{r(\tilde{R}-R_T-R_K)} \times Q_Z^{\otimes r}(z_j^r)} + \frac{Q_S^{\otimes r}(s_j^r) \times W_{Z|X,S}^{\otimes r}(z_j^r | x^r(k_{j-2}, t_{j-1}, m_j), s_j^r)}{2^{r(R+R_t+R_k)} \times Q_Z^{\otimes r}(z_j^r)} + 1 \right) \\
\leq & \log \left(\frac{2^{r(R_T+R_K)} \times 2^{-r(1-\epsilon)(\mathbb{H}(S|V)+\mathbb{H}(Z|X,S))}}{2^{r(R+R_t+R_k+\tilde{R})} \times 2^{-r(1+\epsilon)\mathbb{H}(Z)}} + \frac{2^{r(R_T+R_K)} \times 2^{-r(1-\epsilon)(\mathbb{H}(S|V)+\mathbb{H}(Z|S))}}{2^{r\tilde{R}} \times 2^{-r(1+\epsilon)\mathbb{H}(Z)}} \right. \\
& + \frac{2^{r(R_T+R_K)} \times 2^{-r(1-\epsilon)\mathbb{H}(Z|X)}}{2^{r(R+R_t+R_k+\tilde{R})} \times 2^{-r(1+\epsilon)\mathbb{H}(Z)}} + \frac{2^{-r(1-\epsilon)\mathbb{H}(Z|X)}}{2^{r(R+R_t+R_k)} \times 2^{-r(1+\epsilon)\mathbb{H}(Z)}} + \frac{2^{r(R_T+R_K)} \times 2^{-r(1-\epsilon)\mathbb{H}(Z)}}{2^{r\tilde{R}} \times 2^{-r(1+\epsilon)\mathbb{H}(Z)}} \\
& \left. + \frac{2^{-r(1-\epsilon)\mathbb{H}(S)} \times 2^{-r(1-\epsilon)\mathbb{H}(Z|X,S)}}{2^{r(R+R_t+R_k)} \times 2^{-r(1+\epsilon)\mathbb{H}(Z)}} + 1 \right) \tag{256} \\
\Psi_2 = & \sum_{k_{j-1}, k_j, t_j} \sum_{m_j} \sum_{t_{j-1}} \sum_{k_{j-2}} \sum_{\ell_j} \frac{1}{2^{r(R+R_t+2R_k+R_T+R_K)}} \\
& \times \sum_{(s_j^r, v_j^r, x^r(m_j, t_{j-1}, k_{j-2}), z_j^r) \notin T_\epsilon^{(n)}} \Gamma_{S^r, V^r, X^r, Z^r}^{(\mathcal{C}_n)}(s_j^r, v_j^r, x^r(m_j, t_{j-1}, k_{j-2}), z_j^r) \\
& \times \log \left(\frac{P_{S|V}^{\otimes r}(s_j^r | v_j^r(\ell_j)) \times W_{Z|X,S}^{\otimes r}(z_j^r | x^r(m_j, t_{j-1}, k_{j-2}), s_j^r)}{2^{r(R+R_t+R_k+\tilde{R}-R_T-R_K)} \times Q_Z^{\otimes r}(z_j^r)} \right. \\
& + \frac{P_{S|V}^{\otimes r}(s_j^r | v_j^r(\ell_j)) \times W_{Z|S}^{\otimes r}(z_j^r | s_j^r)}{2^{r(R+R_t+R_k+\tilde{R}-R_T-R_K)} \times Q_Z^{\otimes r}(z_j^r)} \\
& \left. + \frac{\sum_{(\tilde{m}_j, \tilde{t}_{j-1}, \tilde{k}_{j-2}) \neq (m_j, t_{j-1}, k_{j-2})} P_{S|V}^{\otimes r}(\tilde{s}_j^r | v_j^r(\ell_j)) \times W_{Z|X,S}^{\otimes r}(z_j^r | x^r(m_j, t_{j-1}, k_{j-2}), \tilde{s}_j^r)}{2^{r(R+R_t+R_k+\tilde{R}-R_T-R_K)} \times Q_Z^{\otimes r}(z_j^r)} \right)
\end{aligned}$$

$$\begin{aligned}
& + \frac{\sum_{\tilde{s}_j^r \neq s_j^r} \sum_{\tilde{\ell}_j \neq \ell_j} Q_S^{\otimes r}(\tilde{s}_j^r) \times W_{Z|X,S}^{\otimes r}(z_j^r | x^r(m_j, t_{j-1}, k_{j-2}), \tilde{s}_j^r)}{2^{r(R+R_t+R_k+\tilde{R})} \times Q_Z^{\otimes r}(z_j^r)} \\
& + \frac{\sum_{\tilde{s}_j^r \neq s_j^r} \sum_{(\tilde{m}_j, \tilde{t}_{j-1}, \tilde{k}_{j-2}) \neq (m_j, t_{j-1}, k_{j-2})} P_{S|V}^{\otimes r}(\tilde{s}_j^r | v_j^r(\ell_j)) \times W_{Z|S}^{\otimes r}(z_j^r | \tilde{s}_j^r)}{2^{r(R+R_t+R_k+\tilde{R}-R_T-R_K)} \times Q_Z^{\otimes r}(z_j^r)} \\
& + \left. \frac{\sum_{\tilde{\ell}_j \neq \ell_j} Q_S^{\otimes r}(s_j^r) \times W_{Z|X,S}^{\otimes r}(z_j^r | x^r(m_j, t_{j-1}, k_{j-2}), s_j^r)}{2^{r(R+R_t+R_k+\tilde{R})} \times Q_Z^{\otimes r}(z_j^r)} + 1 \right) \\
\leq & \sum_{k_{j-1}, k_j, t_j} \sum_{m_j} \sum_{t_{j-1}} \sum_{k_{j-2}} \sum_{\ell_j} \frac{1}{2^{r(R+R_t+2R_k+R_T+R_K)}} \\
& \times \sum_{(s_j^r, v_j^r, x^r(m_j, t_{j-1}, k_{j-2}), z_j^r) \notin \mathcal{T}_\epsilon^{(n)}} \Gamma_{S^r, V^r, X^r, Z^r}^{(C_n)}(s_j^r, v_j^r, x^r(m_j, t_{j-1}, k_{j-2}), z_j^r) \\
& \times \log \left(\frac{P_{S|V}^{\otimes r}(s_j^r | v_j^r(\ell_j)) \times W_{Z|X,S}^{\otimes r}(z_j^r | x^r(m_j, t_{j-1}, k_{j-2}), s_j^r)}{2^{r(R+R_t+R_k+\tilde{R}-R_T-R_K)} \times Q_Z^{\otimes r}(z_j^r)} + \frac{P_{S|V}^{\otimes r}(s_j^r | v_j^r(\ell_j)) \times W_{Z|S}^{\otimes r}(z_j^r | s_j^r)}{2^{r(\tilde{R}-R_T-R_K)} \times Q_Z^{\otimes r}(z_j^r)} \right) \\
& + \frac{W_{Z|X}^{\otimes r}(z_j^r | x^r(k_{j-2}, t_{j-1}, m_j))}{2^{r(R+R_t+R_k+\tilde{R}-R_T-R_K)} \times Q_Z^{\otimes r}(z_j^r)} + \frac{W_{Z|X}^{\otimes r}(z_j^r | x^r(k_{j-2}, t_{j-1}, m_j))}{2^{r(R+R_t+R_k)} \times Q_Z^{\otimes r}(z_j^r)} \\
& + \left. \frac{Q_Z^{\otimes r}(z_j^r)}{2^{r(\tilde{R}-R_T-R_K)} \times Q_Z^{\otimes r}(z_j^r)} + \frac{Q_S^{\otimes r}(s_j^r) \times W_{Z|X,S}^{\otimes r}(z_j^r | x^r(k_{j-2}, t_{j-1}, m_j), s_j^r)}{2^{r(R+R_t+R_k)} \times Q_Z^{\otimes r}(z_j^r)} + 1 \right) \\
\leq & 2|S||V||X||Z|e^{-r\epsilon\mu_{S,V,X,Z}} r \log\left(\frac{4}{\mu_Z} + 1\right). \tag{257}
\end{aligned}$$

In (257) $\mu_{X,V,S,Z} = \min_{(x,v,s,z) \in (\mathcal{X}, \mathcal{S}, \mathcal{V}, \mathcal{Z})} P_{X,S,V,Z}(x, s, v, z)$ and $\mu_Z = \min_{z \in \mathcal{Z}} P_Z(z)$. When $r \rightarrow \infty$ then $\Psi_2 \rightarrow 0$ and Ψ_1 goes to zero when r grows if

$$R + R_t + R_k + \tilde{R} - R_T - R_K > \mathbb{I}(X; S; Z) - \mathbb{H}(S|V) \tag{258}$$

$$\tilde{R} - R_T - R_K > \mathbb{I}(S; Z) - \mathbb{H}(S|V) \tag{259}$$

$$R + R_t + R_k + \tilde{R} - R_T - R_K > \mathbb{I}(X; Z) \tag{260}$$

$$R + R_t + R_k > \mathbb{I}(X; Z) \tag{261}$$

$$\tilde{R} - R_T - R_K > 0 \tag{262}$$

$$R + R_t + R_k > \mathbb{I}(X, S; Z) - \mathbb{H}(S) \tag{263}$$

where (260) is redundant because of (261) and (262), also (263) is redundant because of (261).

Decoding and Error Probability Analysis: By following the same steps as in [6], the probability of error vanishes when n grows if

$$R + R_t < \mathbb{I}(X; Y). \tag{264}$$

We now analyze the probability of error at the encoder and the decoder for key generation. Let (L_{j-1}, T_{j-1}) denote the chosen indices at the encoder and \hat{L}_{j-1} be the estimate of the index L_{j-1} at the decoder. At the end of block j , by decoding X_j^r , the receiver has access to T_{j-1} . To find L_{j-1} we define the error event

$$\mathcal{E} = \{(V_{j-1}^r(\hat{L}_{j-1}), S_{j-1}^r, X_{j-1}^r, Y_{j-1}^r) \notin \mathcal{T}_\epsilon^{(n)}\}, \tag{265}$$

and consider the events

$$\mathcal{E}_1 = \{(V_{j-1}^r(\ell_{j-1}), S_{j-1}^r) \notin \mathcal{T}_\epsilon^{(n)} \text{ for all } \ell_{j-1} \in \llbracket 1, 2^{r\tilde{R}} \rrbracket\}, \quad (266)$$

$$\mathcal{E}_2 = \{(V_{j-1}^r(L_{j-1}), S_{j-1}^r, X_{j-1}^r, Y_{j-1}^r) \notin \mathcal{T}_\epsilon^{(n)}\}, \quad (267)$$

$$\mathcal{E}_3 = \{(V_{j-1}^r(\tilde{\ell}_{j-1}), X_{j-1}^r, Y_{j-1}^r) \in \mathcal{T}_\epsilon^{(n)} \text{ for some } \ell_{j-1} \in \mathcal{B}(T_{j-1}), \tilde{\ell}_{j-1} \neq \ell_{j-1}\}. \quad (268)$$

By the union bound we have

$$P(\mathcal{E}) \leq P(\mathcal{E}_1) + P(\mathcal{E}_1^c \cap \mathcal{E}_2) + P(\mathcal{E}_3). \quad (269)$$

According to [29, Lemma 2] the first term on the RHS of (269) vanishes when r grows if we have (253). Following the steps in [24, Sec. 11.3.1], the last two terms on the right hand side of (269) go to zero when r grows if we have (253) and

$$\tilde{R} - R_t < \mathbb{I}(V; X, Y). \quad (270)$$

Input Cost Analysis: The proof follows similar lines to [6, Sec V].

By applying Fourier-Motzkin to (253), (258), (259), (261), (262), (264), and (270) and remarking that the scheme requires $R_t + R_k \leq R_T + R_K$ the region in theorem 9 will be derived.

APPENDIX I PROOF OF THEOREM 10

We adopt a block-Markov encoding scheme in which $B - 1$ independent messages are transmitted over B channel blocks each of length r , such that $n = rB$. The warden's observation is $Z^n = (Z_1^r, \dots, Z_B^r)$, the target output distribution is $Q_Z^{\otimes n}$, and Equation (63), describing the distance between the two distributions, continues to hold. The random code generation is as follows:

Fix $P_X(x)$, $P_{S,X,Y,Z}(s, x, y, z) = Q_S(s)P_X(x)W_{YZ|X,S}$, and $\epsilon_1 > \epsilon_2 > 0$ such that, $Q_Z = Q_0$ and $\mathbb{E}[g(X)] \leq \frac{G}{1+\epsilon_2}$.

Codebook Generation for Keys: For each block $j \in \llbracket 1, B \rrbracket$, to generate a key K_j of rate R_K by using the channel state S_j^r , we use Lemma 3 and then, create function $\Phi : S_j^r \rightarrow \llbracket 1, 2^{rR_K} \rrbracket$ through random binning by choosing the value of $\Phi(S_j^r)$ independently and uniformly at random for every $S_j^r \in \mathcal{S}^r$. The key $k_j = \Phi(s_j^r)$ obtained in block $j \in \llbracket 1, B \rrbracket$ from the state sequence s_j^r is used to assist the encoder in the block $j + 2$.

Codebook Generation for Messages: For each block $j \in \llbracket 1, B \rrbracket$, and for each $k_{j-2} \in \llbracket 1, 2^{rR_k} \rrbracket$, $t_{j-1} \in \llbracket 1, 2^{r\tilde{R}} \rrbracket$, and $m_j \in \llbracket 1, 2^{rR} \rrbracket$, randomly and independently generate sequence $x^r(k_{j-2}, t_{j-1}, m_j)$ according to $\prod_{i=1}^r p(x_i)$. These constitute the codebook \mathcal{C}_n . The indices (k_{j-2}, t_{j-1}, m_j) can be seen as a two layer binning.

Encoding: In the first block, the transmitter chooses the indices (k_{-1}, t_0, m_1) uniformly at random; and then based on these indices computes codeword $x^r(k_{-1}, t_0, m_1)$.

In the second block, the transmitter chooses the indices (k_0, m_2) uniformly at random and to generate a secret key shared between the transmitter and the receiver, it selects the reconciliation index $t_1 = \sigma(s_1^n)$; simultaneously the transmitter generates key $k_1 = \Phi(s_1^n)$ from its CSI of the first block. According to the Lemma 3, by decoding the reconciliation index t_1 the receiver is able to reconstruct the channel state of the previous available at the transmitter s_1^r and therefore it can find the index k_1 which will be used as key in the next block.

In block $j \in \llbracket 3, B \rrbracket$, to send message m_j and reconciliation index t_{j-1} according to the generated key k_{j-2} from

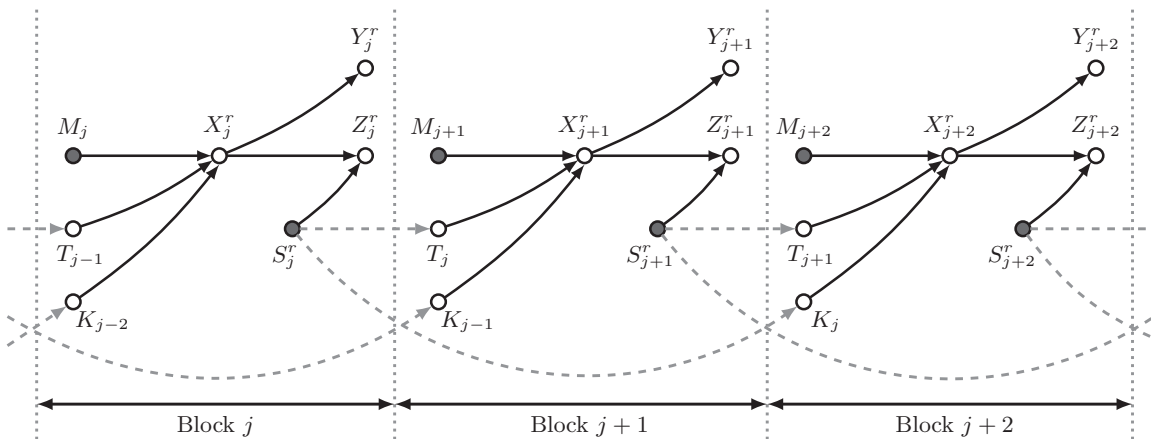

Fig. 13. Functional dependence graph for the block-Markov encoding scheme

the previous block, the encoder computes codeword $x^r(k_{j-2}, t_{j-1}, m_j)$. Simultaneously the transmitter generates key $k_{j-1} = \Phi(s_{j-1}^r)$ from its CSI of the previous block. According to the Lemma 3, by decoding the reconciliation index t_{j-1} the receiver is able to reconstruct the channel state of the previous available at the transmitter s_{j-1}^r and therefore it can find the index k_{j-1} which will be used as key in the next block.

Define

$$\begin{aligned} \Upsilon_{K_{j-2}, T_{j-1}, M_j, X_j^r, S_j^r, Z_j^r, T_j, K_j}^{(\mathcal{C}_n)}(k_{j-2}, t_{j-1}, m_j, \tilde{x}^r, s_{j-1}^r, s_j^r, z_j^r, k_{j-1}, t_j, k_j) &\triangleq Q_S^r(s_j^r) \times 2^{-r(R_k + R_t + R)} \\ &\times \mathbb{1}_{\{x^r(k_{j-2}, t_{j-1}, m_j) = \tilde{x}^r\}} \times W_{Z|X, S}^r(z_j^r | \tilde{x}^r, s_j^r) \times \mathbb{1}_{\{\sigma(s_j^r) = t_j\}} \times \mathbb{1}_{\{\Phi(s_j^r) = k_j\}}. \end{aligned} \quad (271)$$

For a fixed codebook \mathcal{C}_n , the induced joint distribution over the codebook (i.e. $P^{(\mathcal{C}_n)}$) satisfies

$$\|P_{K_{j-2}, T_{j-1}, M_j, S_j^r, L_j, U^r, Z_j^r, K_{j-1}, T_j, K_j}^{(\mathcal{C}_n)} - \Upsilon_{K_{j-2}, T_{j-1}, M_j, S_j^r, L_j, U^r, Z_j^r, K_{j-1}, T_j, K_j}^{(\mathcal{C}_n)}\|_1 \leq \epsilon. \quad (272)$$

This intermediate distribution $\Upsilon^{(\mathcal{C}_n)}$ approximates the true distribution $P^{(\mathcal{C}_n)}$ and will be used in the sequel for bounding purposes. Expression (272) holds because the main difference in $\Upsilon^{(\mathcal{C}_n)}$ is assuming the keys K_{j-2} , K_{j-1} and the reconciliation index T_{j-1} are uniformly distributed, which is made (arbitrarily) nearly uniform in $P^{(\mathcal{C}_n)}$ with appropriate control of rate.

Covert Analysis: We now show that this coding scheme guarantees that $\mathbb{E}_{\mathcal{C}_n}[\mathbb{D}(P_{Z^n}^{(\mathcal{C}_n)} || Q_Z^n)] \xrightarrow[n \rightarrow \infty]{} 0$. Similar to (123) by using functional dependence graph depicted in Fig. 13 it can be shown that

$$\mathbb{D}(P_{Z^n}^{(\mathcal{C}_n)} || Q_Z^n) \leq 2 \sum_{j=1}^B \mathbb{D}(P_{Z_j^r, T_j, K_j}^{(\mathcal{C}_n)} || Q_{Z_j^r}^r Q_{T_j} Q_{K_j}). \quad (273)$$

We now proceed to bound the RHS of (273). First, consider the

$$\begin{aligned} \Upsilon_{Z_j^r, T_j, K_j}^{(\mathcal{C}_n)}(z_j^r, t_j, k_j) &= \sum_{k_{j-2}} \sum_{t_{j-1}} \sum_{m_j} \sum_{s_j^r} \frac{1}{2^{r(R_k + R_t + R)}} \times Q_S^r(s_j^r) \times W_{Z|X, S}^r(z_j^r | x^r(k_{j-2}, t_{j-1}, m_j), s_j^r) \\ &\times \mathbb{1}_{\{\sigma(s_j^r) = t_j\}} \times \mathbb{1}_{\{\Phi(s_j^r) = k_j\}}. \end{aligned} \quad (274)$$

Therefore, from (272)

$$\|\Upsilon_{Z_j^r, T_j, K_j}^{(\mathcal{C}_n)} - P_{Z_j^r, T_j, K_j}^{\mathcal{C}_n}\|_1 \leq \epsilon. \quad (275)$$

To bound the RHS of (273) by using triangle inequality

$$\|P_{Z_j^r, T_j, K_j}^{\mathcal{C}_n} - Q_{Z_j^r}^{\otimes r} Q_{T_j} Q_{K_j}\|_1 \leq \|P_{Z_j^r, T_j, K_j}^{\mathcal{C}_n} - \Upsilon_{Z_j^r, T_j, K_j}^{(\mathcal{C}_n)}\|_1 + \|\Upsilon_{Z_j^r, T_j, K_j}^{(\mathcal{C}_n)} - Q_{Z_j^r}^{\otimes r} Q_{T_j} Q_{K_j}\|_1. \quad (276)$$

The first term on the RHS of (276) goes to zero as n grows, we now analyze the second term on RHS of (276) as follows

$$\begin{aligned}
& \mathbb{E}_{\mathcal{C}_n} [\mathbb{D}(\Upsilon_{Z_j^r, T_j, K_j}^{(\mathcal{C}_n)} || Q_Z^r Q_{T_j} Q_{K_j})] = \mathbb{E}_{\mathcal{C}_n} \left[\sum_{z_j^r, t_j, k_j} \Upsilon^{(\mathcal{C}_n)}(z_j^r, t_j, k_j) \log \left(\frac{\Upsilon^{(\mathcal{C}_n)}(z_j^r, t_j, k_j)}{Q_Z^r(z_j^r) \times Q_{T_j}(t_j) \times Q_{K_j}(k_j)} \right) \right] \\
& = \mathbb{E}_{\mathcal{C}_n} \left[\sum_{z_j^r, t_j, k_j} \sum_{k_{j-2}} \sum_{t_{j-1}} \sum_{m_j} \sum_{s_j^r} \frac{1}{2^{r(R_k+R_t+R)}} \times Q_S^r(s_j^r) \right. \\
& \times W_{Z|X,S}^r(z_j^r | x^r(k_{j-2}, t_{j-1}, m_j), s_j^r) \times \mathbb{1}_{\{\sigma(s_j^r)=t_j\}} \times \mathbb{1}_{\{\Phi(s_j^r)=k_j\}} \\
& \times \log \left(\frac{\sum_{\tilde{k}_{j-2}} \sum_{\tilde{t}_{j-1}} \sum_{\tilde{m}_j} \sum_{\tilde{s}_j^r} Q_S^r(\tilde{s}_j^r) \times W_{Z|X,S}^r(z_j^r | x^r(\tilde{k}_{j-2}, \tilde{t}_{j-1}, \tilde{m}_j), \tilde{s}_j^r) \times \mathbb{1}_{\{\sigma(\tilde{s}_j^r)=\tilde{t}_j\}} \times \mathbb{1}_{\{\Phi(\tilde{s}_j^r)=\tilde{k}_j\}}}{2^{r(R_k+R_t+R-R_T-R_K)} \times Q_Z^r(z_j^r)} \right) \left. \right] \\
& \stackrel{(a)}{\leq} \sum_{z_j^r, t_j, k_j} \sum_{k_{j-2}} \sum_{t_{j-1}} \sum_{m_j} \frac{1}{2^{r(R_k+R_t+R)}} \sum_{s_j^r} \sum_{x^r(k_{j-2}, t_{j-1}, m_j)} \Upsilon_{S_j^r, Z_j^r, X^r}^{(\mathcal{C}_n)}(s_j^r, z_j^r, x^r(k_{j-2}, t_{j-1}, m_j)) \\
& \times \mathbb{E}_{\sigma(s_j^r)} [\mathbb{1}_{\{\sigma(s_j^r)=t_j\}}] \times \mathbb{E}_{\Phi(s_j^r)} [\mathbb{1}_{\{\Phi(s_j^r)=k_j\}}] \\
& \times \log \mathbb{E}_{\setminus((k_{j-2}, t_{j-1}, m_j), \sigma(s_j^r), \Phi(s_j^r))} \left[\frac{1}{2^{r(R_k+R_t+R-R_T-R_K)} \times Q_Z^r(z_j^r)} \right. \\
& \times \left. \sum_{\tilde{k}_{j-2}} \sum_{\tilde{t}_{j-1}} \sum_{\tilde{m}_j} \sum_{\tilde{s}_j^r} Q_S^r(\tilde{s}_j^r) \times W_{Z|X,S}^r(z_j^r | x^r(\tilde{k}_{j-2}, \tilde{t}_{j-1}, \tilde{m}_j), \tilde{s}_j^r) \times \mathbb{1}_{\{\sigma(\tilde{s}_j^r)=\tilde{t}_j\}} \times \mathbb{1}_{\{\Phi(\tilde{s}_j^r)=\tilde{k}_j\}} \right] \\
& \stackrel{(b)}{\leq} \sum_{z_j^r, t_j, k_j} \sum_{k_{j-2}} \sum_{t_{j-1}} \sum_{m_j} \frac{1}{2^{r(R_k+R_t+R)}} \sum_{s_j^r} \sum_{x^r(k_{j-2}, t_{j-1}, m_j)} \Upsilon_{S_j^r, Z_j^r, X^r}^{(\mathcal{C}_n)}(s_j^r, z_j^r, x^r(k_{j-2}, t_{j-1}, m_j)) \times \frac{1}{2^{rR_T}} \times \frac{1}{2^{rR_K}} \\
& \times \log \left(\frac{Q_S^r(s_j^r) \times W_{Z|X,S}^r(z_j^r | x^r(k_{j-2}, t_{j-1}, m_j), s_j^r)}{2^{r(R_k+R_t+R-R_T-R_K)} \times Q_Z^r(z_j^r)} \right. \\
& + \mathbb{E}_{\setminus(k_{j-2}, t_{j-1}, m_j)} \left[\frac{1}{2^{r(R_k+R_t+R-R_T-R_K)} \times Q_Z^r(z_j^r)} \right. \\
& \times \left. \sum_{(\tilde{k}_{j-2}, \tilde{t}_{j-1}, \tilde{m}_j) \neq (k_{j-2}, t_{j-1}, m_j)} Q_S^r(\tilde{s}_j^r) \times W_{Z|X,S}^r(z_j^r | x^r(\tilde{k}_{j-2}, \tilde{t}_{j-1}, \tilde{m}_j), \tilde{s}_j^r) \times \mathbb{1}_{\{\sigma(\tilde{s}_j^r)=\tilde{t}_j\}} \times \mathbb{1}_{\{\Phi(\tilde{s}_j^r)=\tilde{k}_j\}} \right] \\
& + \mathbb{E}_{\setminus(\Phi(s_j^r), \sigma(s_j^r))} \left[\frac{\sum_{\tilde{s}_j^r \neq s_j^r} Q_S^r(\tilde{s}_j^r) \times W_{Z|X,S}^r(z_j^r | x^r(k_{j-2}, t_{j-1}, m_j), \tilde{s}_j^r) \times \mathbb{1}_{\{\sigma(\tilde{s}_j^r)=t_j\}} \times \mathbb{1}_{\{\Phi(\tilde{s}_j^r)=k_j\}}}{2^{r(R_k+R_t+R-R_T-R_K)} \times Q_Z^r(z_j^r)} \right] + 1 \left. \right) \\
& \stackrel{(c)}{\leq} \sum_{z_j^r, t_j, k_j} \sum_{k_{j-2}} \sum_{k_{j-1}} \sum_{m_j} \frac{1}{2^{r(R_k+R_t+R)}} \sum_{s_j^r} \sum_{x^r(k_{j-2}, t_{j-1}, m_j)} \Upsilon_{S_j^r, Z_j^r, X^r}^{(\mathcal{C}_n)}(s_j^r, z_j^r, x^r(k_{j-2}, t_{j-1}, m_j)) \times \frac{1}{2^{rR_T}} \times \frac{1}{2^{rR_K}} \\
& \times \log \left(\frac{Q_S^r(s_j^r) \times W_{Z|X,S}^r(z_j^r | x^r(k_{j-2}, t_{j-1}, m_j), s_j^r)}{2^{r(R_k+R_t+R-R_T-R_K)} \times Q_Z^r(z_j^r)} \right. \\
& + \sum_{(\tilde{k}_{j-2}, \tilde{t}_{j-1}, \tilde{m}_j) \neq (k_{j-2}, t_{j-1}, m_j)} \frac{Q_{S_j^r, Z_j^r}^r(s_j^r, z_j^r)}{2^{r(R_k+R_t+R-R_T-R_K)} \times Q_Z^r(z_j^r)} \\
& + \left. \sum_{\tilde{s}_j^r \neq s_j^r} \frac{Q_S^r(\tilde{s}_j^r) \times W_{Z|X,S}^r(z_j^r | x^r(k_{j-2}, t_{j-1}, m_j), \tilde{s}_j^r)}{2^{r(R_k+R_t+R)} \times Q_Z^r(z_j^r)} + 1 \right) \\
& \triangleq \Psi_1 + \Psi_2, \tag{277}
\end{aligned}$$

where (a) is due to Jensen's inequality, (b) and (c) hold because $\mathbb{1}_{\{\Phi(s_j^r)=k_j\}} \leq 1$. We defined Ψ_1 and Ψ_2 as

$$\begin{aligned}
\Psi_1 &= \sum_{t_j, k_j} \sum_{k_{j-2}} \sum_{t_{j-1}} \sum_{m_j} \frac{1}{2^{r(R_k+R_t+R+R_T+R_K)}} \sum_{(s_j^r, z_j^r, x^r(k_{j-2}, t_{j-1}, m_j)) \in T_\epsilon^{(n)}} \Upsilon_{S^r, Z^r, X^r}^{(C_n)}(s_j^r, z_j^r, x^r(k_{j-2}, t_{j-1}, m_j)) \\
&\quad \times \log \left(\frac{Q_S^r(s_j^r) \times W_{Z|X, S}^r(z_j^r | x^r(k_{j-2}, t_{j-1}, m_j), s_j^r)}{2^{r(R_k+R_t+R-R_T-R_K)} \times Q_Z^r(z_j^r)} \right. \\
&\quad + \sum_{(\tilde{k}_{j-2}, \tilde{t}_{j-1}, \tilde{m}_j) \neq (k_{j-2}, t_{j-1}, m_j)} \frac{Q_{S, Z}^r(s_j^r, z_j^r)}{2^{r(R_k+R_t+R-R_T-R_K)} \times Q_Z^r(z_j^r)} \\
&\quad \left. + \sum_{\tilde{s}_j^r \neq s_j^r} \frac{Q_S^r(\tilde{s}_j^r) \times W_{Z|X, S}^r(z_j^r | x^r(k_{j-2}, t_{j-1}, m_j), \tilde{s}_j^r)}{2^{r(R_k+R_t+R)} \times Q_Z^r(z_j^r)} + 1 \right) \\
&\leq \sum_{t_j, k_j} \sum_{k_{j-2}} \sum_{t_{j-1}} \sum_{m_j} \frac{1}{2^{r(R_k+R_t+R+R_T+R_K)}} \sum_{(s_j^r, z_j^r, x^r(k_{j-2}, t_{j-1}, m_j)) \in T_\epsilon^{(n)}} \Upsilon_{S^r, Z^r, X^r}^{(C_n)}(s_j^r, z_j^r, x^r(k_{j-2}, t_{j-1}, m_j)) \\
&\quad \times \log \left(\frac{Q_S^r(s_j^r) \times W_{Z|X, S}^r(z_j^r | x^r(k_{j-2}, t_{j-1}, m_j), s_j^r)}{2^{r(R_k+R_t+R-R_T-R_K)} \times Q_Z^r(z_j^r)} + \frac{2^{r(R_T+R_K)} \times Q_{S, Z}^r(s_j^r, z_j^r)}{Q_Z^r(z_j^r)} \right. \\
&\quad \left. + \frac{W_{Z|X}^r(z_j^r | x^r(k_{j-2}, t_{j-1}, m_j))}{2^{r(R_k+R_t+R)} \times Q_Z^r(z_j^r)} + 1 \right) \\
&\leq \log \left(\frac{2^{r(R_T+R_K)} 2^{-r(1-\epsilon)\mathbb{H}(S, Z|X)}}{2^{r(R_k+R_t+R)} 2^{-r(1+\epsilon)\mathbb{H}(Z)}} + \frac{2^{r(R_T+R_K)} 2^{-r(1-\epsilon)\mathbb{H}(S, Z)}}{2^{-r(1+\epsilon)\mathbb{H}(Z)}} + \frac{2^{-r(1-\epsilon)\mathbb{H}(Z|X)}}{2^{r(R_k+R_t+R)} 2^{-r(1+\epsilon)\mathbb{H}(Z)}} + 1 \right) \quad (278) \\
\Psi_2 &= \sum_{t_j, k_j} \sum_{k_{j-2}} \sum_{t_{j-1}} \sum_{m_j} \frac{1}{2^{r(R_k+R_t+R+R_T+R_K)}} \sum_{(s_j^r, z_j^r, x^r(k_{j-2}, t_{j-1}, m_j)) \notin T_\epsilon^{(n)}} \Upsilon_{S^r, Z^r, X^r}^{(C_n)}(s_j^r, z_j^r, x^r(k_{j-2}, t_{j-1}, m_j)) \\
&\quad \times \log \left(\frac{Q_S^r(s_j^r) \times W_{Z|X, S}^r(z_j^r | x^r(k_{j-2}, t_{j-1}, m_j), s_j^r)}{2^{r(R_k+R_t+R-R_T-R_K)} \times Q_Z^r(z_j^r)} \right. \\
&\quad + \sum_{(\tilde{k}_{j-2}, \tilde{t}_{j-1}, \tilde{m}_j) \neq (k_{j-2}, t_{j-1}, m_j)} \frac{Q_{S, Z}^r(s_j^r, z_j^r)}{2^{r(R_k+R_t+R-R_T-R_K)} \times Q_Z^r(z_j^r)} \\
&\quad \left. + \sum_{\tilde{s}_j^r \neq s_j^r} \frac{Q_S^r(\tilde{s}_j^r) \times W_{Z|X, S}^r(z_j^r | x^r(k_{j-2}, t_{j-1}, m_j), \tilde{s}_j^r)}{2^{r(R_k+R_t+R)} \times Q_Z^r(z_j^r)} + 1 \right) \\
&\leq \sum_{t_j, k_j} \sum_{k_{j-2}} \sum_{t_{j-1}} \sum_{m_j} \frac{1}{2^{r(R_k+R_t+R+R_T+R_K)}} \sum_{(s_j^r, z_j^r, x^r(k_{j-2}, t_{j-1}, m_j)) \notin T_\epsilon^{(n)}} \Upsilon_{S^r, Z^r, X^r}^{(C_n)}(s_j^r, z_j^r, x^r(k_{j-2}, t_{j-1}, m_j)) \\
&\quad \times \log \left(\frac{Q_S^r(s_j^r) \times W_{Z|X, S}^r(z_j^r | x^r(k_{j-2}, t_{j-1}, m_j), s_j^r)}{2^{r(R_k+R_t+R-R_T-R_K)} \times Q_Z^r(z_j^r)} + \frac{2^{r(R_T+R_K)} \times Q_{S, Z}^r(s_j^r, z_j^r)}{Q_Z^r(z_j^r)} \right. \\
&\quad \left. + \frac{W_{Z|X}^r(z_j^r | x^r(k_{j-2}, t_{j-1}, m_j))}{2^{r(R_k+R_t+R)} \times Q_Z^r(z_j^r)} + 1 \right) \\
&\leq 2|S||Z||X| e^{-r\epsilon\mu_{S, Z, X}} \log \left(\frac{3}{\mu_Z} + 1 \right). \quad (279)
\end{aligned}$$

In (279) $\mu_{X, S, Z} = \min_{(u, s, z) \in (\mathcal{X}, \mathcal{S}, \mathcal{Z})} \Upsilon_{X, S, Z}(u, s, z)$ and $\mu_Z = \min_{z \in \mathcal{Z}} \Upsilon_Z(z)$. When $r \rightarrow \infty$ then $\Psi_2 \rightarrow 0$ and if we choose $R_T + R_K = \mathbb{H}(S|Z) - \epsilon$, Ψ_1 goes to zero when r grows if

$$R_k + R_t + R > \mathbb{I}(X; Z|S), \quad (280)$$

$$R_k + R_t + R > \mathbb{I}(X; Z) \quad (281)$$

where (281) is redundant because of (280).

Decoding and Error Probability Analysis: By following the same steps as in [6], the probability of error vanishes when n grows if

$$R_t + R \leq \mathbb{I}(X; Y). \quad (282)$$

Input Cost Analysis: The proof follows similar lines to [6, Sec V].

By applying Fourier-Motzkin to (160), (280), (282), and remarking that the scheme requires $R_t + R_k \leq R_T + R_K = \mathbb{H}(S|Z) - \epsilon$ the following region is derived,

$$R \leq \mathbb{I}(X; Y) - \mathbb{H}(S|X, Y), \quad (283)$$

$$R \geq \mathbb{I}(X; Z|S) - \mathbb{H}(S|Z). \quad (284)$$

One can easily check that if (283) and (284) hold the region in Theorem 10 is also hold. The region in Theorem 10 also results to (283) and (284) because if (39) holds we can find a rate R which satisfies both (283) and (284).

REFERENCES

- [1] A. B. Bash, D. Goeckel, and D. Towsley, "Limits of reliable communication with low probability of detection on AWGN channels," *IEEE J. Sel. Areas Commun.*, vol. 31, no. 9, pp. 1921–1930, Sep. 2013.
- [2] P. H. Che, M. Bakshi, and S. Jaggi, "Reliable deniable communication: Hiding messages in noise," in *Proc. IEEE Int. Symp. on Info. Theory (ISIT)*, Istanbul, Turkey, Jul. 2013, pp. 2945–2949.
- [3] L. Wang, G. W. Wornell, and L. Zheng, "Fundamental limits of communication with low probability of detection," *IEEE Trans. Inf. Theory*, vol. 62, no. 6, pp. 3493–3503, Jun. 2016.
- [4] M. R. Bloch, "Covert communication over noisy channels: A resolvability perspective," *IEEE Trans. Inf. Theory*, vol. 62, no. 5, pp. 2334–2354, May 2016.
- [5] M. Tahmasbi and M. R. Bloch, "First- and second-order asymptotics in covert communication," *IEEE Trans. Inf. Theory*, vol. 65, no. 4, pp. 2190–2212, Apr. 2019.
- [6] S.-H. Lee, L. Wang, A. Khisti, and G. W. Wornell, "Covert communication with channel-state information at the transmitter," *IEEE Trans. Inf. Forensics Security*, vol. 13, no. 9, pp. 2310–2319, Sep. 2018.
- [7] H. ZivariFard, M. R. Bloch, and A. Nosratinia, "Keyless covert communication in the presence of non-causal channel state information," in *Accepted in Information Theory Workshop (ITW)*, 2019.
- [8] S. Salehkalaibar, M. H. Yassaee, and V. Y. F. Tan, "Covert communication over a compound channel," *available at <https://arxiv.org/abs/1906.06675>*, Jun. 2019.
- [9] P.-H. Lin, C. R. Janda, and E. A. Jorswieck, "Stealthy secret key generation," in *Proc. IEEE Global Conf. on Signal and Info. Processing (GlobalSIP)*, Montreal, QC, Canada, Mar. 2017, pp. 492–496.
- [10] P.-H. Lin, C. R. Janda, E. A. Jorswieck, and R. F. Schaefer, "Stealthy keyless secret key generation from degraded sources," in *51st Asilomar Conference on Signals, Systems, and Computers*, Pacific Grove, CA, USA, Apr. 2018, pp. 14–18.
- [11] M. Tahmasbi and M. R. Bloch, "Covert secret key generation," in *Proc. IEEE Conf. on Commun. and Network Security (CNS)*, Las Vegas, NV, USA, Dec. 2017, pp. 540–544.
- [12] —, "Framework for covert and secret key expansion over classical-quantum channels," *Phys. Rev. A*, vol. 99, p. 052329, May 2019.
- [13] Y. Chen and A. J. Han Vinck, "Wiretap channel with side information," *IEEE Trans. Inf. Theory*, vol. 54, no. 1, pp. 395–402, Jan. 2008.
- [14] A. Khisti, S. N. Diggavi, and G. W. Wornell, "Secret key agreement using asymmetry in channel state knowledge," in *Proc. IEEE Int. Symp. on Info. Theory (ISIT)*, Seoul, South Korea, Jul. 2009, pp. 2286–2290.
- [15] Y.-K. Chia and A. El Gamal, "Wiretap channel with causal state information," *IEEE Trans. Inf. Theory*, vol. 58, no. 5, pp. 2838–2849, May 2012.
- [16] H. Fujita, "On the secrecy capacity of wiretap channels with side information at the transmitter," *IEEE Trans. Inf. Forensics Security*, vol. 11, no. 11, pp. 2441–2452, Nov. 2016.

- [17] A. Sonee and G. A. Hodtani, "Wiretap channel with strictly causal side information at encoder," in *Proc. Iran Workshop on commun. and Info. Theory (IWCIT)*, Tehran, Iran, May 2014, pp. 1–6.
- [18] T. S. Han and M. Sasaki, "Wiretap channels with causal state information: Strong secrecy," *IEEE Trans. Inf. Theory*, vol. 65, no. 10, pp. 6750–6765, Oct. 2019.
- [19] Z. Goldfeld, P. Cuff, and H. H. Permuter, "Wiretap channels with random states non-causally available at the encoder," available at <https://arxiv.org/abs/1608.00743>, Aug. 2016.
- [20] E. L. Lehmann and J. P. Romano, *Testing Statistical Hypotheses*. New York, NY, USA: Springer-Verlag, 2005.
- [21] C. S. Song, P. Cuff, and H. V. Poor, "The likelihood encoder for lossy compression," *IEEE Trans. Inf. Theory*, vol. 62, no. 4, pp. 1836–1849, Apr. 2016.
- [22] J. Hou, "Coding for relay networks and effective secrecy for wiretap channels," in *Ph.D. dissertation, Faculty Electrotech. Informationstech., Technische Univ. Mnchen*, Munich, Germany, 2014.
- [23] A. Lapidoth and Y. Steinberg, "The multiple access channel with causal and strictly causal side information at the encoders," in *Int. Zurich Semin. Commun.*, Zurich, Switzerland, Mar. 2010, pp. 13–16.
- [24] A. El Gamal and Y.-H. Kim, *Network Information Theory*, 1st ed. Cambridge, U.K: Cambridge University Press, 2012.
- [25] M. H. Yassaee and M. R. Aref, "Multiple access wiretap channels with strong secrecy," in *Proc. IEEE Info. Theory Workshop (ITW)*, Dublin, Ireland, Sep. 2010, pp. 1–5.
- [26] E. C. Song, P. Cuff, and H. V. Poor, "A rate-distortion based secrecy system with side information at the decoders," in *Proc. 52th Annual Allerton Conference on Communication, Control, and Computing*, Monticello, IL, Sep. 2014, pp. 755–762.
- [27] D. Slepian and J. K. Wolf, "A coding theorem for multiple access channels with correlated sources," *Bell System Technical Journal*, vol. 52, no. 7, pp. 1037–1076, Sep. 1973.
- [28] P. Cuff, "Distributed channel synthesis," *IEEE Trans. Inf. Theory*, vol. 59, no. 11, pp. 7071–7096, Nov. 2013.
- [29] Z. Goldfeld, G. Kramer, H. H. Permuter, and P. Cuff, "Strong secrecy for cooperative broadcast channels," *IEEE Trans. Inf. Theory*, vol. 63, no. 19, pp. 469–495, Jan. 2017.