

A Breezing Proof of the KMW Bound

CORINNA COUPETTE, MPI for Informatics and Saarbrücken Graduate School of Computer Science, Germany

CHRISTOPH LENZEN, MPI for Informatics, Germany

In their seminal paper from 2004, Kuhn, Moscibroda, and Wattenhofer (KMW) proved a hardness result for several fundamental graph problems in the LOCAL model: For any (randomized) algorithm, there are input graphs with n nodes and maximum degree Δ on which $\Omega(\min\{\sqrt{\log n/\log \log n}, \log \Delta/\log \log \Delta\})$ (expected) communication rounds are required to obtain polylogarithmic approximations to a minimum vertex cover, minimum dominating set, or maximum matching, respectively. Via reduction, this hardness extends to symmetry breaking tasks like finding maximal independent sets or maximal matchings. Today, more than 15 years later, there is still no proof of this result that is easy on the reader. Setting out to change this, in this work, we provide a fully self-contained and *simple* proof of the KMW lower bound. The key argument is algorithmic, and it relies on an invariant that can be readily verified from the generation rules of the lower bound graphs.

CCS Concepts: • **Theory of computation** → **Distributed algorithms**; • **Computing methodologies** → **Distributed algorithms**; • **Mathematics of computing** → *Graph theory*.

Additional Key Words and Phrases: LOCAL model, lower bounds, indistinguishability

1 INTRODUCTION AND RELATED WORK

A key property governing the complexity of distributed graph problems is their *locality*: the distance up to which the nodes running a distributed algorithm need to explore the graph to determine their local output. Under the standard assumption that nodes have unique identifiers, the locality of any task is at most D , the diameter of the graph. However, many problems of interest have locality $o(D)$, and understanding the locality of fundamental graph problems has been a main objective of the distributed computing community since the inception of the field.

A milestone in these efforts is the 2004 article by Kuhn, Moscibroda, and Wattenhofer, which proves a lower bound of $\Omega(\min\{\sqrt{\log n/\log \log n}, \log \Delta/\log \log \Delta\})$ on the locality of several basic graph problems [18], where n is the number of nodes and Δ is the maximum degree of the input graph. The bound holds under both randomization and approximation, and it was the first result of this generality beyond the classic $\Omega(\log^* n)$ bound on 3-coloring cycles [24].¹ Linial’s bound has received much attention over the years, with various extensions [9, 14, 15, 23, 25] and alternative proofs [22, 29]. A recent wave of major results [3, 7, 8], based on what has been termed *round elimination*, can be seen as generalizing Linial’s technique further.

Despite its significance, apart from an early extension to maximum matching by the same authors [19], the KMW lower bound has not inspired follow-up results. One reason might be that the result itself is not as well-understood. History itself appears to drive this point home: In a 2010 arXiv article [20], an improvement to $\Omega(\min\{\sqrt{\log n}, \log \Delta\})$ was claimed, which was refuted in 2016 by Bar-Yehuda et al. [6] but is still cited in more recent papers [15]. 2016 was also the year when finally a journal article covering the lower bound was published [21]—over a decade after the initial construction! In the journal article, the technical core of the proof spans six pages and involves fairly convoluted notation. While there is no objective measure of simplicity, we believe that a more digestible proof is highly desirable.

¹We disregard the bounds of $\Omega(n)$ on 2-coloring cycles and $\Omega(d)$ on $(\sqrt{\Delta} - 1)$ -coloring Δ -regular trees of depth d , also due to Linial. Essentially, they show that these tasks are *global*, i.e., have locality $\Theta(D)$. Many tasks were known to be global early on, which typically follows from trivial arguments.

Our Contribution

In this work, we present a novel proof of the KMW bound. Our main contribution is to replace the heart of the argument, showing that certain nodes have indistinguishable k -hop neighborhoods, with a proof based on an algorithmic invariant. Our algorithm constructs the graph isomorphism between the nodes' neighborhoods, where the key observation is that a simple invariant is sufficient to overcome the main obstacle, referred to by Kuhn et al. as the “critical path.” This results in a much shorter and more straightforward argument proving the intuition that the respective graph is crafted “just right” to ensure that the relevant nodes' views are indistinguishable up to distance k . Our second contribution is a fully self-contained and easily accessible presentation of the proof. Ideally, a single pass through the paper should suffice to understand the full reasoning, without reliance on statements shown elsewhere. We hope that this provides a solid foundation for future work that may extend the KMW result.

Further Related Work

The KMW bound applies to fundamental graph problems that are locally checkable in the sense of Naor and Stockmeyer [25]. Balliu et al. give an overview of the known time complexity classes for such problems [4], extending a number of prior works [11–13], and Suomela surveys the state of the art attainable via constant-time algorithms [28]. Bar-Yehuda et al. provide algorithms that compute $(2 + \epsilon)$ -approximations to minimum (weighted) vertex cover and maximum (weighted) matching in $O(\log \Delta / \epsilon \log \log \Delta)$ and $O(\log \Delta / \log \log \Delta)$ deterministic rounds, respectively [5, 6], demonstrating that the KMW bound is tight when parametrized by Δ even for constant approximation ratios. For symmetry breaking tasks, the classic algorithm by Panconesi and Rizzi [26] to compute maximal matchings and maximal independent sets in $O(\log^* n + \Delta)$ deterministic rounds has recently been shown to be optimal for a wide range of parameters [3].

Overview

After introducing basic graph theoretical concepts and notation in Section 2, we define the lower bound graphs in Section 3.1. We infer the order and the maximum degree of these graphs in Section 3.2, and prove the indistinguishability of certain nodes assuming high girth in Section 3.3. To ensure that lower bound graphs with high girth exist, we construct such graphs with low girth in Section 4.1 and lift them to high girth in Section 4.3 with the help of regular graphs introduced in Section 4.2. We derive the KMW bound for polylogarithmic approximations to a minimum vertex cover in Section 5. Extensions of the KMW bound to other graph problems can be found in the appendix.

2 PRELIMINARIES

The main implications of the KMW construction are lower bounds on the running time of algorithms in the LOCAL model of computation [27]. However, these bounds follow from purely graph theoretic properties of the structure. Hence, we confine our presentation to these properties and refer the reader to [27] for a discussion of the LOCAL model.

The basic notation used in this work is summarized in Table 1 (p. 3); unless otherwise specified, all our graphs are finite and simple. The key notion used to show that a graph problem is difficult to solve (exactly or approximately) for a k -round distributed algorithm is the k -hop *indistinguishability* of nodes' neighborhoods. Intuitively, this means that an algorithm examining the graph up to distance k from two nodes v and w will observe identical topologies around v and w , respectively. In the following, we formalize this concept.

Definition 2.1 (*k-hop neighborhood* $\Gamma_G^k(v)$). The *k*-hop neighborhood of a node v in G is the set of nodes at distance at most k from v (not including v itself), i.e., $\Gamma^k(v) := \{w \in V(G) \mid d(v, w) \leq k, v \neq w\}$.

Symbol	Definition	Meaning
$[k]$	$\{i \in \mathbb{N} \mid i \leq k\}$	Set of positive integers not larger than k
$[k]_0$	$\{i \in \mathbb{N}_0 \mid i \leq k\}$	Set of nonnegative integers not larger than k
G	$(V(G), E(G))$	Graph G with node set $V(G)$ and edge set $E(G)$
$G[S]$	$(S, E[S]), E[S] := \{\{v_i, v_j\} \in E \mid v_i, v_j \in S\}$	Subgraph of G induced by $S \subseteq V(G)$
n_G	$ V(G) $	Number of nodes in G (<i>order</i> of G)
m_G	$ E(G) $	Number of edges in G (<i>size</i> of G)
$\Gamma_G(v)$	$\{w \in V(G) \mid \{v, w\} \in E(G)\}$	Neighborhood of v in G (as a node set)
$\delta_G(v)$	$ \Gamma_G(v) $	Degree of v in G
Δ_G	$\max\{\delta(v) \mid v \in V(G)\}$	Largest degree of a node $v \in V(G)$
$p_G(u, w)$	$(\{v_0, v_1\}, \{v_1, v_2\}, \dots, \{v_{k-1}, v_k\}),$ $v_0 = u, v_k = w, \{v_i, v_j\} \in E \forall i, j \in [k]_0: j = i + 1, v_i \neq v_j$	Path from u to w in G
$d_G(u, w)$	$\min\{i \mid \exists p(u, w): p(u, w) = i\}$	Distance between node u and node w in G (∞ if there exists no path between u and w)
$d_G(u, e)$	$\min\{i \mid \exists w, p(u, w): p(u, w) = i \wedge e \in p(u, w)\}$	Distance between node u and edge e in G (∞ if there exists no path between u and e)
g_G	$\min\{i > 0 \mid \exists v, p(v, v): p(v, v) = i\}$	Girth of G (length of its shortest cycle)
$\Gamma_G^k(v)$	$\{w \in V(G) \mid d(v, w) \leq k, v \neq w\}$	<i>k</i> -hop neighborhood of a node v in G , not including v itself (\rightarrow Definition 2.1)
$G^k(v)$	$G[\Gamma^k(v) \cup \{v\}] \setminus \{e \in E(G) \mid d(v, e) > k\}$	<i>k</i> -hop subgraph of a node v in G , including v itself (\rightarrow Definition 2.2)
$G_1 \subseteq G_2$	$\Leftrightarrow V(G_1) \subseteq V(G_2) \wedge E(G_1) \subseteq E(G_2)$	Subgraph relationship between G_1 and G_2
$G_1 \cong G_2$	$\Leftrightarrow \exists \phi: V(G_1) \rightarrow V(G_2)$ bijective s.t. $\{v, w\} \in E(G_1) \Leftrightarrow \{\phi(v), \phi(w)\} \in E(G_2)$	Graph isomorphism between G_1 and G_2

Table 1. General notation used in this work (subscript or parenthesized G may be omitted when clear from context).

Assuming that nodes do not know their direct neighbors at the start, the topology discoverable by a *k*-round algorithm corresponds to the following definition:

Definition 2.2 (*k-hop subgraph* $G^k(v)$). The *k*-hop subgraph of a node v in G is the subgraph induced by v and its *k*-hop neighborhood, restricted to the edges at distance at most k from v , i.e.,

$$G^k(v) = G[\Gamma^k(v) \cup \{v\}] \setminus \{e \in E(G) \mid d(v, e) > k\}.$$

A *k*-round algorithm in the LOCAL model can be interpreted as a function from *k*-hop subgraphs to local outputs:

Definition 2.3 (*k-round distributed algorithm*). A *k*-round distributed algorithm \mathcal{A} is a function mapping *k*-hop subgraphs $G^k(v)$, labeled by unique node identifiers (and potentially some local input), to local outputs. For a randomized algorithm, nodes are also labeled by (sufficiently long) strings of independent, unbiased random bits.

Intuitively, two nodes in a graph are indistinguishable to a *k*-round distributed algorithm if and only if these nodes see identical topologies within *k* hops (including identical inputs). This intuition is formalized by the following definition:

Definition 2.4 (*k-hop indistinguishability in G*). Two nodes v and w in G are indistinguishable to a *k*-round algorithm (*k*-hop indistinguishable) if and only if their *k*-hop subgraphs (labeled by inputs) are isomorphic, i.e., $G^k(v) \cong G^k(w)$.

Note that Definition 2.4 (p. 3) disregards the node identifiers, which can be chosen uniformly at random. Furthermore, no known application of the construction has inputs.

3 CLUSTER TREES

The Cluster Tree (CT) is the main gadget in the derivation of the KMW bound. For $k \in \mathbb{N}$, Kuhn et al. define a structure CT_k and graphs G_k conforming to this structure that are particularly hard to handle for (deterministic or randomized) distributed algorithms. We refer to the structure CT_k as the *Cluster Tree skeleton (CT skeleton)* and to the graphs G_k as the *Cluster Tree graphs (CT graphs)*; together, they constitute the CT as a *concept*.

CT graphs trade off between conflicting goals:

- (1) Only a small fraction of nodes should participate in optimal solutions for, e.g., a minimum vertex cover.
- (2) A large fraction of nodes should be k -hop indistinguishable from such “important” nodes.

To satisfy these requirements, the CT pursues a two-level strategy: In a first step, the macro-level structure of the CT graph family is defined. This is achieved by the CT skeleton, which already contains enough information for us to reason, *inter alia*, about node indistinguishability in CT graphs—provided we assume that these graphs are locally tree-like, i.e., have girth $g \geq 2k + 1$. In a second step, the micro-level structure of the CT graphs is designed within the constraints laid out by the CT skeleton. Here, special effort goes into crafting CT graphs that meet the girth constraint.

3.1 Definition

CT skeletons specify the macro-level structure with which the CT graphs must comply. For $k \in \mathbb{N}$, CT_k dictates the connectivity pattern of G_k . It does not, however, establish the precise adjacency relationships between nodes in G_k , nor does it fix their exact number.

CT_k is a tree whose vertices, termed *clusters*, represent independent sets of nodes in G_k . A pair of complementary directed labeled edges between clusters C_i and C_j , which we collectively refer to as an *arc* and denote as $\langle\langle C_i, x_i \rangle, \langle C_j, x_j \rangle\rangle$ for $x_i, x_j \in \mathbb{N}$ (where the order of the tuples in the angular brackets does not matter), indicates that the clusters are connected as a biregular bipartite graph. Here, the edge labels x_i and x_j show how many neighbors a node from cluster C_i has in cluster C_j , and vice versa.² We also say that C_i is connected to C_j via *outgoing label* x_i .

For a given k , CT_k has $k + 2$ levels, numbered from 0 to $k + 1$, where we refer to the level of a cluster C as $l(C)$, and 0 is the *lowest* level. For all k , CT_k has exactly one cluster on level 0, referred to as the *root cluster* C_0 . Clusters with more than one neighboring cluster are *internal* clusters (with cluster position *internal*); all other clusters are *leaf* clusters (with cluster position *leaf*). We call nodes in internal clusters *internal nodes* and nodes in leaf clusters *leaf nodes*.

Given a parameter $\beta \geq 2(k + 1)$,³ the structure of CT_k is defined inductively. The base case for the construction is CT_1 , which consists of four clusters and three arcs:

Definition 3.1 (The trunk CT_1). $CT_1 = (C_1, \mathcal{A}_1)$, where

$$C_1 := \{C_0, C_1, C_2, C_3\} \text{ and } \mathcal{A}_1 := \{\langle\langle C_0, \beta^0 \rangle, \langle C_1, \beta^1 \rangle\rangle, \langle\langle C_0, \beta^1 \rangle, \langle C_2, \beta^2 \rangle\rangle, \langle\langle C_1, \beta^0 \rangle, \langle C_3, \beta^1 \rangle\rangle\}.$$

CT_1 has two internal clusters: C_0 and C_1 . We refer to these clusters as *core clusters*, and to nodes in one of the core clusters as *core nodes*. Figure 1 (p. 5) shows CT_1 in its hierarchical and flat representations, where we write x for an arc label β^x (i.e., we represent arc labels by their logarithms) to reduce visual clutter. In the flat representation, arc

²Since we are dealing with biregular bipartite graphs, one edge label in an arc can be inferred from the other. We keep both labels because this simplifies later parts of our exposition (as does the representation of an arc as a pair of directed edges).

³In [18, 21], β is referred to as δ . We deliberately avoid δ because it is usually used to denote the degree of a node in a graph.

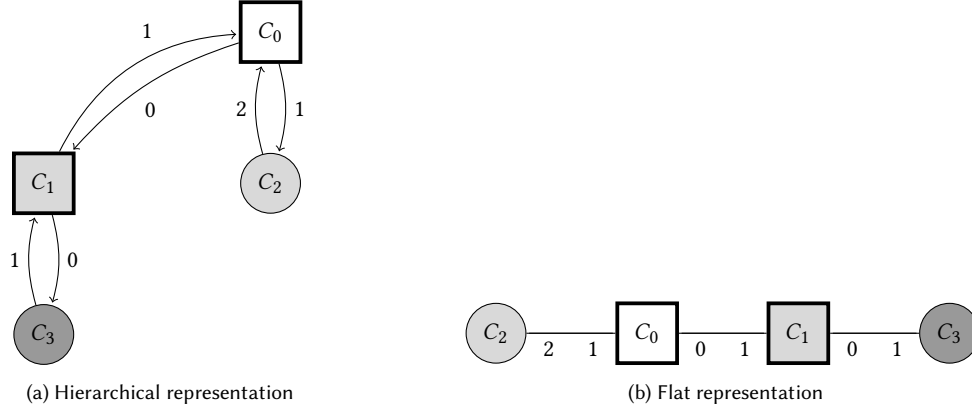

Fig. 1. Representations of CT_1 (shaded by cluster sizes; darker means smaller). Cluster shapes indicate cluster position (*internal or leaf*); core clusters are depicted with bold frame. Arc labels are to be read as exponents of the parameter β .

labels are presented like port numbers of a networking device on the undirected edges incident to the clusters that are connected by the arc.

Based on CT_{k-1} , for $k \geq 2$, CT_k is grown as follows.

Definition 3.2 (Growth rules for CT_k given CT_{k-1}).

- (1) To each internal cluster C_i in CT_{k-1} , attach a new neighboring cluster C'_i via an arc $\langle (C_i, \beta^k), (C'_i, \beta^{k+1}) \rangle$. We call such added leaf clusters *branch instantiation clusters*.
- (2) To each leaf cluster C_i in CT_{k-1} that has β^q neighbors in its parent cluster, add k neighboring clusters C'_i with arcs $\langle (C_i, \beta^p), (C'_i, \beta^{p+1}) \rangle$ for all $p \in [k]_0 \setminus \{q\}$. We call such added leaf clusters *branch consolidation clusters*.

To illustrate the growth process, the hierarchical and flat representations of CT_2 as well as a flat representation of CT_3 are given in Figure 2 (p. 6). For readability, the labels of the arcs connecting the newly added clusters in CT_3 to the rest of the CT skeleton are omitted in the drawing. By construction, they are such that every internal cluster has outgoing labels $\{\beta^i \mid i \in [3]_0\}$, and if a leaf cluster C is connected to an internal cluster C' with label β^i outgoing from C' , then C has outgoing label β^{i+1} .

The arc constraints enforce that the new leaf clusters lie on the level above their parent clusters (and hence, are drawn *below* their parent clusters in hierarchical representations), and that all leaf clusters of CT_{k-1} are internal clusters in CT_k . Furthermore, by construction, all nodes in internal clusters of CT_k have degree $\sum_{i=0}^k \beta^i$, and all nodes in branch instantiation clusters have degree β^{k+1} . The number of neighbors for nodes in a branch consolidation cluster, however, depends on the labels of the arc connecting that cluster to the rest of CT_k .

To express whether two nodes are in the same cluster in CT_k without having to specify unique identifiers for all clusters, and to facilitate the exposition, we equip each node in G_k with a *cluster identity*:

Definition 3.3 (Cluster identity $C(v)$). Given a node v in a CT graph G_k , we refer to its cluster in CT_k as its *cluster identity*, denoted as $C(v)$. For example, for $v_0 \in C_0$ and $v_1 \in C_1$, we have $C(v_0) = C_0$, $C(v_1) = C_1$, and $C(v_0) \neq C(v_1)$.

3.2 Order and Maximum Degree of Cluster Tree Graphs

First, we determine the number of clusters on each level of CT_k .

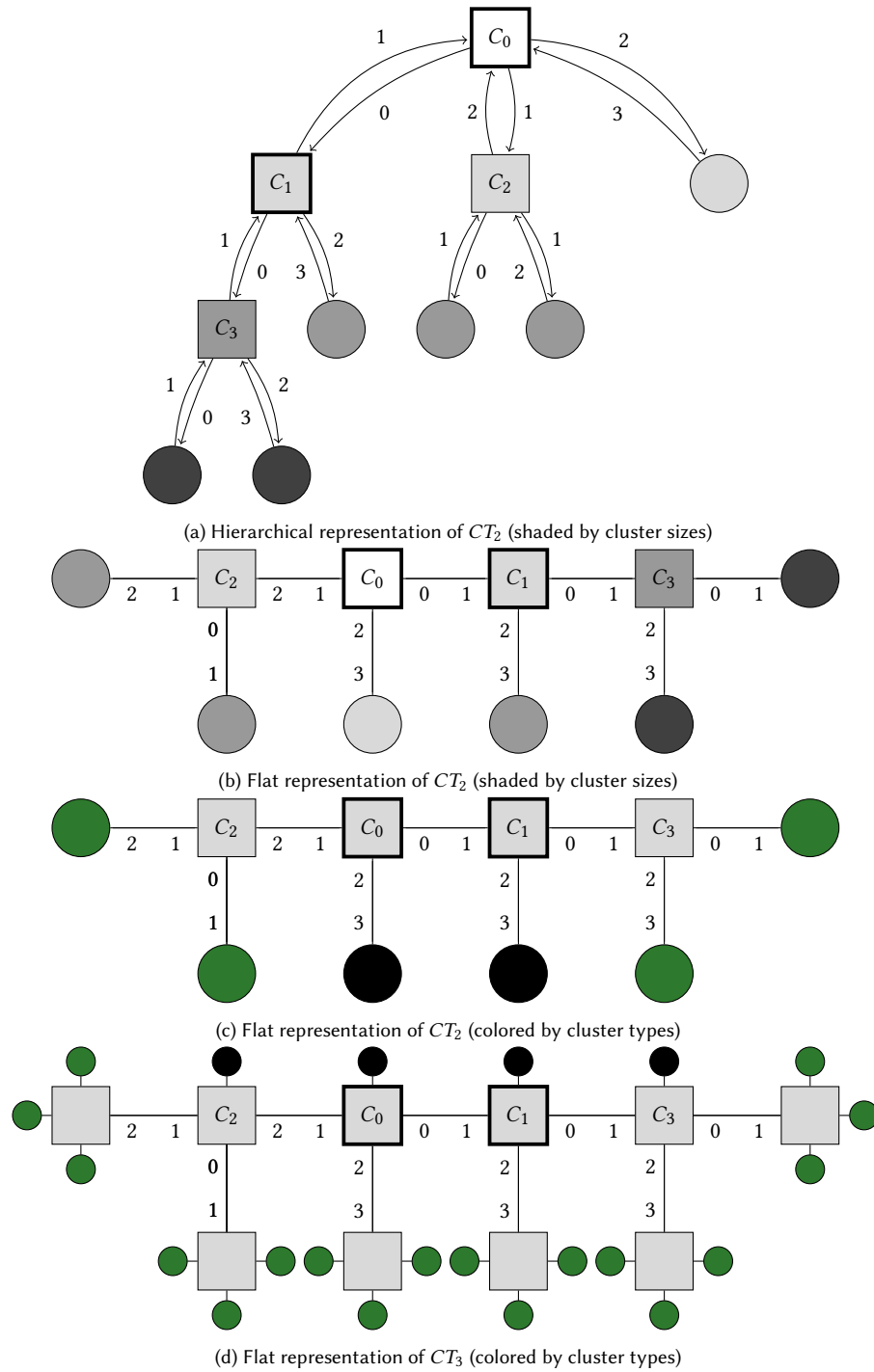

Fig. 2. Representations of CT_2 and CT_3 . Cluster shapes correspond to cluster position (*internal* or *leaf*); core clusters depicted with bold frame. Arc labels are to be read as exponents of the parameter β .

THEOREM 3.4 (ORDER OF CT SKELETONS BY LEVEL). For $k \in \mathbb{N}$, the number of clusters n_C on level $l \in \mathbb{N}_0$ in CT_k is⁴

$$n_C(k, l) = \begin{cases} 1 & l = 0 \\ \frac{k!}{(k-l+1)!} \cdot (k-l+2) & 1 \leq l \leq k+1 \\ 0 & l > k+1. \end{cases}$$

PROOF. Observe that for $l = 1$, $\frac{k!}{(k-l+1)!} \cdot (k-l+2) = k+1$. We now proceed by induction on k . For $k = 1$, we have one cluster on the zeroth level, two clusters on the first level, and one cluster on the second level, as illustrated in Figure 1 (p. 5). Since $n_C(1, 0) = 1$, $n_C(1, 1) = \frac{1!}{1!} \cdot 2 = 2$, $n_C(1, 2) = \frac{1!}{0!} \cdot 1 = 1$, and $n_C(1, l) = 0$ for all $l > 2$, the claim holds for the base case, i.e., for $k = 1$ and all l , the number of clusters on a level l in CT_k is given by the formula stated above.

Therefore, assume that the claim holds for some k , i.e., in CT_k , the number of clusters on level l is given by $n_C(k, l)$. Due to the arc constraints, which enforce that all new leaf clusters lie on the level above their parent clusters, the number of clusters on the zeroth level always remains one. Since the cluster on the zeroth level is an internal cluster already in CT_1 , it is an internal cluster also in CT_k , and by growth rule 1, exactly one cluster is added on the level above the zeroth level when transitioning to CT_{k+1} . Therefore, if CT_k has $k+1$ clusters on the first level, CT_{k+1} has $k+2$ clusters on the first level. Furthermore, new clusters are added only on levels at most one above already existing clusters, so if CT_k has no clusters on levels above $k+1$, CT_{k+1} has no clusters on levels above $k+2$. With these observations, for $l = 0$, $l = 1$, and $l > k+1$, the number of clusters on level l in CT_{k+1} is given by the formula stated in the theorem.

For the remaining levels, i.e., levels l with $1 < l \leq k+1$, observe that by the growth rules of CT_k , all clusters present on level l in CT_k are guaranteed to be internal clusters in CT_{k+1} , with $k+1$ children on level $l+1$, and these child clusters are the only clusters on level $l+1$. Thus, for $k, l \geq 1$, the number of clusters satisfies the recurrence relation

$$n_C(k+1, l+1) = (k+1) \cdot n_C(k, l).$$

By the inductive hypothesis, we have for l with $1 \leq l \leq k+1$ that $n_C(k, l) = \frac{k!}{(k-l+1)!} \cdot (k-l+2)$. Therefore,

$$n_C(k+1, l+1) = (k+1) \cdot n_C(k, l) = \frac{(k+1)!}{(k-l+1)!} \cdot (k-l+2) = \frac{(k+1)!}{((k+1)-(l+1)+1)!} \cdot ((k+1)-(l+1)+2),$$

as required. As this verifies the claimed expression for $n_C(k+1, l)$ for all $1 < l \leq k+2$, this completes the inductive step, concluding the proof. \square

From the connectivity structure prescribed by CT_k , we can derive constraints regarding the number of nodes in G_k :

- (1) For $k > 1$, the number of nodes in a cluster of CT_k on level $k+1$ must be at least β^k , since there is always at least one branch instantiation cluster C' on level $k+1$, and nodes in the parent cluster of C' have β^k neighbors in C' .
- (2) To ensure that the arc labels (β^i, β^{i+1}) define feasible biregular bipartite graphs for all $i \in [k]_0$, the number of nodes in a single cluster must fall by a factor of β per level.
- (3) Combining the above requirements, for $k > 1$, in the smallest graph G_k satisfying CT_k , clusters on level l have β^{2k-l+1} nodes, e.g., a cluster on level $k+1$ has β^k nodes, and C_0 has β^{2k+1} nodes.

More generally, we can express the order of G_k in terms of $n_0 := |V(C_0)|$, k , and β :

⁴Following widespread conventions, we set $0! := 1$, and $\prod_{i=j}^k x := 1$ if $j > k$.

LEMMA 3.5 (*n* IN TERMS OF n_0). In G_k , $n < n_0 \left(\frac{\beta}{\beta - (k+1)} \right)$ and $n - n_0 < n_0 \cdot \frac{2(k+1)}{\beta}$.

PROOF. By Theorem 3.4 (p. 7) and the discussion above, the number of nodes on level $l \in \mathbb{N}_0$ in G_k as a function of β , k , l , and n_0 is $n(\beta, k, l, n_0) = n_C(k, l) \cdot n_0 \cdot \beta^{-l}$. Because $n = \sum_{l=0}^{\infty} n(\beta, k, l, n_0) = \sum_{l=0}^{k+1} n(\beta, k, l, n_0)$, we get

$$\begin{aligned} n &= n_0 + n_0 \cdot \sum_{l=1}^{k+1} \frac{k!}{(k-l+1)!} \cdot (k-l+2) \cdot \beta^{-l} \leq n_0 + n_0 \cdot \sum_{l=1}^{k+1} \frac{k!(k+1)}{(k-l+1)!} \cdot \frac{1}{\beta^l} \\ &< n_0 + n_0 \cdot \sum_{l=1}^{k+1} \frac{(k+1)^l}{\beta^l} = n_0 \sum_{l=0}^{k+1} \left(\frac{k+1}{\beta} \right)^l < n_0 \sum_{l=0}^{\infty} \left(\frac{k+1}{\beta} \right)^l = n_0 \cdot \frac{\beta}{\beta - (k+1)}, \end{aligned}$$

where the last step uses that $\beta > k+1$. Leveraging our requirement that $\beta \geq 2(k+1)$, we obtain

$$n - n_0 < n_0 \cdot \left(\frac{\beta}{\beta - (k+1)} - 1 \right) = n_0 \cdot \frac{k+1}{\beta - (k+1)} \leq n_0 \cdot \frac{2(k+1)}{\beta}. \quad \square$$

The construction of CT_k further dictates the largest degree Δ of a node in G_k :

LEMMA 3.6 (LARGEST DEGREE Δ OF G_k). The largest degree of a node in G_k is $\Delta = \beta^{k+1}$.

PROOF. All internal nodes have degree $\sum_{i=0}^k \beta^i$, and the largest degree of leaf nodes is β^{k+1} . As $\beta \geq 2(k+1) > 2$, $\max\{\sum_{i=0}^k \beta^i, \beta^{k+1}\} = \beta^{k+1}$. \square

3.3 Indistinguishability given High Girth

As observed by Kuhn et al. [18, 21], arguing about the k -hop indistinguishability of nodes in a graph becomes easier when we know that the nodes' k -hop subgraphs (in [21]: k -hop neighborhoods) are trees, which is ensured if the graph has girth $g \geq 2k+1$. Notably, in a CT graph G_k with girth $g \geq 2k+1$, the topology of a node's k -hop subgraph is determined entirely by the structure of the skeleton CT_k . Hence, without knowing the details of G_k , we can establish:

THEOREM 3.7 (k -HOP INDISTINGUISHABILITY OF NODES IN C_0 FROM NODES IN C_1). Let G_k be a graph conforming to CT_k . If G_k has girth $g \geq 2k+1$, and there are no local inputs, then $v_0 \in C_0$ and $v_1 \in C_1$ are k -hop indistinguishable.

By Definition 2.4 (p. 3), $v_0 \in C_0$ and $v_1 \in C_1$ are k -hop indistinguishable if and only if their k -hop subgraphs are isomorphic, i.e., $G_k^k(v_0) \cong G_k^k(v_1)$.⁵ We prove the theorem constructively by showing the correctness of Algorithm 1 (p. 9), which purports to find an isomorphism $\phi : V(G_k^k(v_0)) \rightarrow V(G_k^k(v_1))$.

Algorithm 1 (p. 9) implements a *coupled depth-first search (coupled DFS)* on the k -hop subgraphs of $v_0 \in C_0$ and $v_1 \in C_1$.⁶ The main function, `FINDISOMORPHISM`(G_k, k, v_0, v_1), receives a CT graph G_k with high girth, along with the parameter k (both of which we assume to be accessible by the functions we call internally, alongside the mapping from nodes to their clusters), and one node from each of C_0 and C_1 as input, and it outputs the ϕ we are looking for. To obtain ϕ , `FINDISOMORPHISM` maps v_0 to v_1 and then calls the function `WALK`(v_0, v_1, \perp, k) before it returns ϕ . The `WALK` function modifies ϕ by mapping the *newly discovered* nodes in the neighborhoods of its first two input parameters (v and $w := \phi(v)$, initially: v_0 and v_1) to each other with the help of the function `MAP`. The third parameter of `WALK` (*prev*, initially: \perp) ensures that we only define ϕ for newly discovered nodes, while the fourth parameter (*depth*, initially: k) controls termination when `WALK` calls itself recursively on the newly discovered neighbors (and the newly discovered neighbors of these neighbors, and so on) until the entire k -hop subgraph of v_0 has been visited.

⁵Observe that $G_k^k(v) \cong G_k^k(w)$ trivially holds in G_k with high girth if $v, w \in C_0$ or $v, w \in C_1$.

⁶For brevity, we do not keep track of the nodes we find in this procedure. This could easily be achieved at the expense of additional lines of code.

Algorithm 1: Find an isomorphism $\phi : V(G_k^k(v_0)) \rightarrow V(G_k^k(v_1))$

```

1 Function FINDISOMORPHISM( $G_k, k, v_0, v_1$ ):
   Input:  $G_k$  conforming to  $CT_k$  with  $g \geq 2k + 1, k \in \mathbb{N}, v_0 \in C_0, v_1 \in C_1$ 
   Output: Isomorphism  $\phi : V(G_k^k(v_0)) \rightarrow V(G_k^k(v_1))$ 
2    $\phi \leftarrow$  empty map
3    $\phi(v_0) \leftarrow v_1$ 
4   WALK( $v_0, v_1, \perp, k$ )
5   return  $\phi$ 

6 Function WALK( $v, w, prev, depth$ ):
7   if  $depth = 0$  then
8     return
9    $N_v \leftarrow$  empty list of length  $k + 2$ 
10   $N_w \leftarrow$  empty list of length  $k + 2$ 
11  for  $i \leftarrow 0$  to  $k + 1$  do
12    // if edge  $\beta^i$  does not exist, the respective list is empty
13     $N_v[i] \leftarrow$  list of new nodes  $v' \neq prev$  found using edge  $\beta^i$  from  $v$ 
14     $N_w[i] \leftarrow$  list of new nodes  $w' \neq \phi(prev)$  found using edge  $\beta^i$  from  $w$ 
15  MAP( $N_v, N_w$ )
16  for  $i \leftarrow 0$  to  $k + 1$  do
17    for  $v'$  in  $N_v[i]$  do
18      WALK( $v', \phi(v'), v, depth - 1$ )

18 Function MAP( $N_v, N_w$ ):
19  for  $i \leftarrow 0$  to  $k + 1$  do
20    // zip( $\cdot, \cdot$ ) yields element tuples until the shorter list ends
21    for  $v', w'$  in zip( $N_v[i], N_w[i]$ ) do
22       $\phi(v') \leftarrow w'$ 
23    //  $len(\cdot)$  returns the length of a list
24    if  $\exists i \in [k + 1]_0 : len(N_v[i]) \neq len(N_w[i])$  then
25       $u_v \leftarrow i \in [k + 1]_0 : len(N_v[i]) = len(N_w[i]) + 1$ 
26       $u_w \leftarrow i \in [k + 1]_0 : len(N_v[i]) + 1 = len(N_w[i])$ 
27      //  $L[u_v][-1]$  retrieves the last element from list  $u_v$  in  $L$ 
28       $\phi(N_v[u_v][-1]) = N_w[u_w][-1]$ 

```

The tricky part now is to ascertain that the interplay between the functions WALK and MAP makes ϕ a bijection from $V(G_k^k(v_0))$ to $V(G_k^k(v_1))$, i.e., nodes that are paired up always have the same degree. Here, the representation of node neighborhoods used by the WALK function is key, which is based on the insight that the set of nodes neighboring v (w) can be partitioned by the outgoing labels in CT_k through which neighboring nodes are discovered from v (w). Since these labels lie in $\{\beta^i \mid i \in [k + 1]_0\}$, WALK represents the neighborhood of v (w) as a list N_v (N_w) of $k + 2$ (possibly empty) lists (Algorithm 1, l. 9–13, p. 9). The list at index i holds all *previously undiscovered* nodes (we require $v' \neq prev$ and $w' \neq \phi(prev)$) connected to v (w) via v 's (w 's) outgoing label β^i , in any order (e.g., sorted by their node identifiers).

The WALK function passes N_v and N_w to the function MAP (Algorithm 1, l. 14, p. 9), which sets $\phi(N_v[i][j]) := N_w[i][j]$ where possible (Algorithm 1, l. 19–21, p. 9). It then treats the special case that some nodes in N_v and N_w remain unmatched (Algorithm 1, l. 22–25, p. 9). By construction, without this special case, the ϕ returned by FINDISOMORPHISM is already an isomorphism between the subgraphs of $G_k^k(v_0)$ and $G_k^k(v_1)$ induced by the nodes of the domain for which ϕ is defined (and their images under ϕ). However, we still need to show that our special case suffices to extend this restricted isomorphism to a full isomorphism between $G_k^k(v_0)$ and $G_k^k(v_1)$. We start with a simple observation:

LEMMA 3.8 (VARIABLES DETERMINING NODE NEIGHBORHOODS). *For v in $G_k^k(v_0) \setminus \{v_0\}$, let $w := \phi(v)$. When MAP is called with parameters N_v and N_w (Algorithm 1 l. 14, p. 9), the numbers of nodes in $N_v[i]$ and $N_w[i]$ for $i \in [k+1]_0$ are uniquely determined by two parameters:*

- (1) **position:** the position of the clusters $C(v)$ and $C(w)$ in the CT skeleton (internal or leaf), and
- (2) **history:** the outgoing labels of the arcs connecting $C(v)$ to $C(\text{prev})$ and $C(w)$ to $C(\phi(\text{prev}))$, i.e., β^x and β^y if the corresponding arcs are $\langle (C(v), \beta^x), (C(\text{prev}), \beta^{x'}) \rangle$ and $\langle (C(w), \beta^y), (C(\text{prev}), \beta^{y'}) \rangle$ for some $x', y' \in [k+1]_0$.

In particular, if v and w agree on position and history, $\text{len}(N_v[i]) = \text{len}(N_w[i])$ for all $i \in [k+1]_0$. If v and w agree on position internal but disagree on history, we have $\text{len}(N_v[i]) = \text{len}(N_w[i])$ for all $i \in [k+1]_0 \setminus \{x, y\}$, $\text{len}(N_v[x]) = \text{len}(N_w[y]) - 1$, and $\text{len}(N_v[y]) - 1 = \text{len}(N_w[x])$.

PROOF. If $u \in \{v, w\}$ has position *internal*, we know that $C(u)$ has outgoing labels $\{\beta^i \mid i \in [k]_0\}$ by the construction of the CT skeleton. Denoting by $z \in \{x, y\}$ the exponent of u 's history, we have that there are β^i nodes in $N_u[i]$ for $i \in [k]_0 \setminus \{z\}$, $\beta^z - 1$ nodes in $N_u[z]$ (as *prev* or $\phi(\text{prev})$ are removed, respectively), and zero nodes in $N_u[k+1]$.

If u has position *leaf*, all nodes in N_u belong to the same cluster C' , u has β^z neighbors in this cluster, and *prev* (resp. $\phi(\text{prev})$) lies in this cluster as well. Hence, $\text{len}(N_u[z]) = \beta^z - 1$ and $\text{len}(N_u[i]) = 0$ for all $i \in [k+1]_0 \setminus \{z\}$.

From these observations, the claims of the lemma follow immediately. \square

COROLLARY 3.9 (SUFFICIENT CONDITION FOR CORRECTNESS OF ALGORITHM 1). *Given a CT graph G_k with girth at least $2k+1$, if during the recursive calls to WALK, MAP always pairs only nodes that (i) agree on position and history or (ii) agree on position internal, Algorithm 1 (p. 9) produces an isomorphism between $G_k^k(v_0)$ and $G_k^k(v_1)$.*

PROOF. Note that Algorithm 1 (p. 9) produces an isomorphism between $G_k^k(v_0)$ and $G_k^k(v_1)$ if $\phi|_{N_v}$ (i.e., ϕ with its domain restricted to the neighborhood of v) is a bijection from N_v to $N_{\phi(v)}$ for all v in $G_k^k(v_0)$ with $d(v, v_0) < k$. For v_0 and $\phi(v_0) = v_1$, this holds because they both have β^i neighbors in the clusters connected to them via outgoing edge label β^i for $i \in [k]_0$, i.e., $\text{len}(N_v[i]) = \text{len}(N_w[i])$ for $i \in [k]_0$ (and $\text{len}(N_v[k+1]) = \text{len}(N_w[k+1]) = 0$). Hence, MAP ensures that $\phi(N_v) = N_w$. For nodes $v \neq v_0$ and $w := \phi(v)$ paired by MAP that agree on *position* and *history*, Lemma 3.8 (p. 10) shows that $\text{len}(N_v[i]) = \text{len}(N_w[i])$ for all $i \in [k+1]_0$ as well, so again MAP succeeds. The final case is that v and w agree on position *internal*. In this case, applying Lemma 3.8 (p. 10) and noting that MAP takes care of the mismatch in list length between $N_v[x]$ and $N_v[y]$ in Lines 22–25 proves that MAP succeeds here as well. \square

Recall that due to the inductive construction of CT_k , for all $i \in [k]$, we can view CT_i as a subgraph of CT_k by simply stripping away all nodes that were added after constructing CT_i . Recall also that $G_k^k(v_0)$ and $G_k^k(v_1)$ are trees, because the girth of G_k is at least $2k+1$. Treating these trees as rooted at v_0 and v_1 , respectively, Algorithm 1 (p. 9) maps nodes at depth d in $G_k^k(v_0)$ to nodes at depth d in $G_k^k(v_1)$. To ensure that the preconditions of Corollary 3.9 (p. 10) hold, we prove the following invariant of Algorithm 1 (p. 9), whose intuition is illustrated in Figure 3 (p. 11):

Definition 3.10 (Main Invariant of Algorithm 1). For $0 < d < k$, suppose that v and $w := \phi(v)$ lie at distance d from v_0 and v_1 , respectively. Then exactly one of the following holds:

- (1) $C(v), C(w) \in CT_d$, and if v and w disagree on *history*, their histories are at most β^{d+1} , or
- (2) there is some i with $d < i \leq k$ such that $C(v), C(w) \in CT_i \setminus CT_{i-1}$, and v and w agree on *history*.

Note that in the first case, v and w agree on position *internal*, and in the second case, v and w agree on *position* and *history*. Thus, Theorem 3.7 (p. 8) readily follows from Corollary 3.9 (p. 10) once the invariant is established.

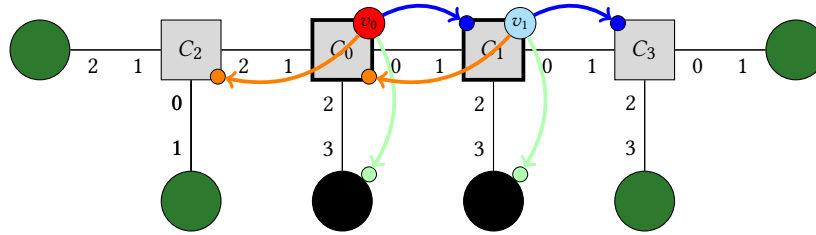

(a) $d = 1$ from v_0 and v_1 : for the blue nodes, the first case of the invariant holds *with* agreement on *history*; for the orange nodes, the first case of the invariant holds *without* agreement on *history*; and for the green nodes, the second case of the invariant holds.

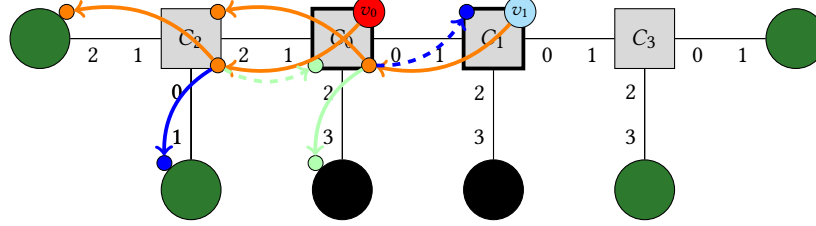

(b) $d = 2$ from orange nodes at distance $d = 1$: for the newly discovered green and blue nodes, the first case of the invariant holds *without* agreement on *history*; for the newly discovered orange nodes, the first case of the invariant holds *with* agreement on *history*.

Fig. 3. Illustration of Definition 3.10 (p. 11) for CT_2 . Cluster colors, shapes, and borders drawn as in Figure 2 (p. 6). Nodes $v_0 \in C_0$ and $v_1 \in C_1$ indicated as medium-size circles; representatives of nodes seen via a certain outgoing edge depicted as small circles and connected to their parents by arrows. Node and arrow colors show outgoing edge labels (e.g., blue nodes are seen via the outgoing edge β^0); dashed arrows indicate that $\beta^i - 1$, rather than β^i , nodes are discovered via the outgoing label indicated by the arrow color.

LEMMA 3.11 (MAIN INVARIANT HOLDS). *Algorithm 1 (p. 9) satisfies the invariant stated in Definition 3.10 (p. 11).*

PROOF. We prove the claim for fixed k by induction on d . For v and $w := \phi(v)$ at distance $d = 1$ from $v_0 = p_0(v)$ and $v_1 = p_1(w)$, respectively, v and w are matched in the initial call to WALK with v_0 and v_1 as arguments. In this call, $N_{v_0}[i] = N_{v_1}[i]$ for all $i \in [k + 1]_0$, i.e., only nodes corresponding to the same outgoing arc labels get matched. Inspecting CT_1 and taking into account the CT growth rules, we see that for $i \in \{0, 1\}$, the matched nodes lie in clusters that are present already in CT_1 and have incoming labels of at most β^2 (i.e., the first case of the invariant holds), while for $i > 1 = d$, both nodes lie in clusters from $CT_i \setminus CT_{i-1}$ with incoming labels of β^{i+1} (i.e., the second case of the invariant holds).

For the inductive step, assume that the invariant is established up to distance d for $1 \leq d < k - 1$, and consider v , $w := \phi(v)$ at distance $d + 1$ from v_0 and v_1 , respectively. We apply the invariant to $v' := p_0(v)$ and $w' := p_1(w)$ and distinguish between its two cases.

(1) Suppose that $C(v'), C(w') \in CT_d$ with *histories* that are identical or at most β^{d+1} . As $d < k$, v' and w' agree on *position* *internal*. By Lemma 3.8 (p. 10), the call to WALK on v' and w' thus satisfies that $\text{len}(N_{v'}[i]) = \text{len}(N_{w'}[i])$ for all $i \in [k+1]_0 \setminus \{j, j'\}$ and some $j, j' \leq d+1$. If $C(v) \in CT_{d+1}$, Lemma 3.8 (p. 10) entails that $v \in N_{v'}[i]$ for some $i \leq d+1$, and WALK chooses $w = \phi(v)$ from $N_{w'}[i']$ for some $i' \leq d+1$. Due to the CT growth rules, if $C(v'), C(w') \in CT_d$, then the incident arcs of $C(v')$ and $C(w')$ with outgoing labels of at most β^{d+1} lead to clusters in CT_{d+1} , and the incoming label of the respective edges is at most β^{d+2} . Hence, $v \in CT_{d+1}$ entails that the first case of the invariant holds for v and w . If $C(v) \notin CT_{d+1}$, we have that $v \in CT_i \setminus CT_{i-1}$ for some $i > d+1$, yielding $\text{len}(N_{v'}[i]) = \text{len}(N_{w'}[i])$, and hence, $w \in N_{w'}[i]$. As $C(v')$ and $C(w')$ are internal clusters in CT_{d+1} , we can conclude that both $C(v)$ and $C(w)$ have been added to the cluster tree in the i^{th} step of the construction using growth rule 1. Hence, we get that $C(v), C(w) \in CT_i \setminus CT_{i-1}$ with v and w agreeing on *history* β^{i+1} , i.e., the second case of the invariant holds for v and w .

(2) Assume that there is some i with $d < i \leq k$ such that $C(v'), C(w') \in CT_i \setminus CT_{i-1}$, and v' and w' agree on *history*. By the CT growth rules, v' and w' also agree on *position*, so $v \in N_{v'}[j]$ and $w \in N_{w'}[j]$ for the same $j \in [k+1]_0$ by Lemma 3.8 (p. 10). Checking these growth rules, we see that $C(v')$ and $C(w')$ must have been attached to clusters from CT_{i-1} with arc labels $(\beta^{j'}, \beta^{j'+1})$ for the same $j' \in [i]_0$, and that they have no other neighboring clusters in CT_i . Hence, if $j \neq j' + 1$, then $C(v), C(w) \in CT_{i+1} \setminus CT_i$, and as $i + 1 > d + 1$, the second case of the invariant holds for v and w . If $j = j' + 1$, by the above observations, $C(v) = C(p_0(v'))$ and $C(w) = C(p_1(w'))$. As WALK mapped v' to $\phi(v') =: w'$, we have that $p_0(v')$ was mapped to $\phi(p_0(v')) = p_1(w')$, where $p_0(v')$ and $p_1(w')$ lie at distance $d - 1$ from v_0 and v_1 , respectively. Applying the invariant to these nodes, the first case and the second case with $i \leq d + 1$ both imply that $C(v), C(w) \in CT_{d+1}$, establishing the first case of the invariant for v and w . And if the second case applies with $i > d + 1$, then the second case of the invariant holds for v and w . \square

With this result, we can summarize:

PROOF OF THEOREM 3.7 (P. 8). Follows from the correctness of Algorithm 1 (p. 9) for $k \in \mathbb{N}$ and CT graphs G_k with girth at least $2k + 1$, established via Lemma 3.11 (p. 11) and Corollary 3.9 (p. 10). \square

4 ENSURING HIGH GIRTH

To construct CT graphs with high girth, we rely on special *graph homomorphisms* called *graph lifts*:

Definition 4.1 (Graph homomorphism). Graph G_1 is *homomorphic* to graph G_2 if there is a function $\phi: V(G_1) \rightarrow V(G_2)$ s.t. $\{v, w\} \in E(G_1) \Rightarrow \{\phi(v), \phi(w)\} \in E(G_2)$ (i.e., ϕ is adjacency-preserving); ϕ is called a *homomorphism*.

Definition 4.2 (Graph lift). Graph G_1 is a *lift* of graph G_2 if there is a *surjective* homomorphism $\phi: V(G_1) \rightarrow V(G_2)$ s.t. $\forall v \in V(G_1): \{v, w\} \in E(G_1) \Leftrightarrow \{\phi|_{\Gamma(v)}(v), \phi|_{\Gamma(v)}(w)\} \in E(G_2)$ (i.e., ϕ is *locally* bijective); ϕ is called a *covering map*.

We establish the existence of a CT graph G_k with girth $g \geq 2k + 1$ and $O(\beta^{2k^2+4k+1})$ nodes using the setup illustrated in Figure 4 (p. 13). The intuition of this setup is that we obtain G_k as a subgraph of \tilde{H}_k , which is a common lift of a high-girth graph H_k and a graph H'_k that is a supergraph of a low-girth CT graph G'_k . Since taking lifts and subgraphs cannot decrease the girth,⁷ G_k then has large girth, and because G_k is a lift of G'_k , it conforms to CT_k .

Table 2 (p. 13) gives an overview of the graphs involved in our setup, along with the properties we seek to establish and the reference to their existence proofs.

⁷For subgraphs, this is obvious. For lifts, consider a cycle of length l in the lift and observe that a covering map must map it to a subgraph containing a cycle of length at most l .

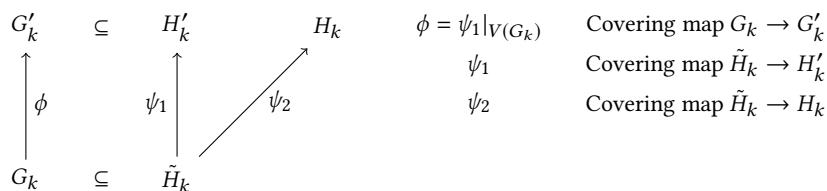

Fig. 4. Setup used to establish the existence of CT graphs with high girth.

Graph	Properties	Existence Proof
G'_k	CT graph, parametrized by β , $\beta^{O(k)}$ nodes, maximum degree $\Delta = \beta^{k+1}$	Definition 4.3, Lemma 4.4
H'_k	Δ -regular, supergraph of G'_k , $\beta^{O(k)}$ nodes	Lemma 4.5, Corollary 4.7
H_k	Δ -regular, girth $g = 2k + 1$, $O(\Delta^{2k}) \subseteq \beta^{O(k^2)}$ nodes	Lemma 4.6, Corollary 4.7
\tilde{H}_k	Δ -regular, lift of H'_k and H_k , girth $g \geq 2k + 1$, $\beta^{O(k^2)}$ nodes	Lemma 4.8, Corollary 4.9
G_k	CT graph, subgraph of \tilde{H}_k , girth $g \geq 2k + 1$, $\beta^{O(k^2)}$ nodes	Theorem 4.10

Table 2. Proof overview for establishing the existence of CT graphs with high girth.

4.1 Low-Girth Cluster Tree Graphs

We can easily construct low-girth CT graphs by plugging together complete bipartite graphs.

Definition 4.3 (G'_k from complete bipartite graphs). For $k \in \mathbb{N}$ and a parameter $\beta \in \mathbb{N}$, let CT_k be the CT skeleton parametrized by β . We construct G'_k conforming to CT_k as follows:

- (1) For each cluster C on level $l \in [k + 1]_0$ in CT_k , add β^{2k-l+1} nodes v with $C(v) = C$ to G_k .
- (2) For clusters C and C' with $\langle (C, \beta^x), (C', \beta^{x+1}) \rangle \in E(CT_k)$, connect the nodes representing these clusters in G_k using $\frac{|C|}{\beta^{x+1}}$ copies of $K_{\beta^x, \beta^{x+1}}$, the complete bipartite graph on $A \cup B$ with $|A| = \beta^x$ and $|B| = \beta^{x+1}$.

LEMMA 4.4 (CT GRAPH STRUCTURE). For $k \in \mathbb{N}$, graphs following Definition 4.3 (p. 13) conform with CT_k .

PROOF. As can be easily verified from the definition of CT_1 and the growth rules, in CT_k , all arcs are of the form $\langle (C, \beta^x), (C', \beta^{x+1}) \rangle$ for some $x \in [k + 1]_0$, where C is on level $\ell \in [k]_0$ and C' on level $\ell + 1$. By Definition 4.3, we thus have that $|C'| = \frac{|C|}{\beta}$. Now, $\frac{|C|}{\beta^{x+1}}$ copies of $K_{\beta^x, \beta^{x+1}}$ contain $\frac{|C|}{\beta^{x+1}} \cdot \beta^{x+1} = |C|$ nodes with degree β^x and $\frac{|C|}{\beta^{x+1}} \cdot \beta^x = \frac{|C|}{\beta} = |C'|$ nodes with degree β^{x+1} . Hence, using $\frac{|C|}{\beta^{x+1}}$ copies of $K_{\beta^x, \beta^{x+1}}$, we exactly fulfill the requirements imposed by CT_k on the connectivity between C and C' . \square

4.2 Regular Graphs with Desirable Properties

The construction from Definition 4.3 (p. 13) results in CT graphs of girth four. We now set up the machinery needed to lift these low-girth graphs to high girth. First, we embed G'_k into a Δ -regular graph.

LEMMA 4.5 (Δ -REGULAR SUPERGRAPHS OF GENERAL GRAPHS). Let G be a simple graph with maximum degree Δ . Then there exists a Δ -regular supergraph H of G with $|V(H)| < |V(G)| + 4\Delta$.⁸

⁸ A bound of $|V(H)| \leq |V(G)| + \Delta + 2$ that is optimal in the worst case is shown in [1].

PROOF. Let $G = (V, E)$ with maximum degree Δ . We modify G to form H as follows. While there are nodes $v, w \in V$ with degree $\delta(v) < \Delta$, $\delta(w) < \Delta$, and $\{v, w\} \notin E$, we add $\{v, w\}$ to E . Let D be the set of remaining nodes with degree less than Δ . By construction, we know that the nodes in D form a clique of size at most Δ .

Now add a complete bipartite graph $K_{\Delta, \Delta}$ and rewire edges as follows. By Hall's Theorem [16, 17], $K_{\Delta, \Delta}$ has Δ disjoint perfect matchings. Assign to each $v \in D$ a unique such matching, remove $\lfloor (\Delta - \delta(v))/2 \rfloor$ of its edges, and connect all endpoints of these edges to v . Afterwards, nodes in D are missing at most one edge, while all other nodes have degree Δ .

Next, arbitrarily match the nodes still missing edges. For each such pair $(v, w) \in D^2$, choose a remaining edge from the matching of v in $K_{\Delta, \Delta}$ ($\lfloor (\Delta - \delta(v))/2 \rfloor > 0$ remain), remove it, connect v to one of its endpoints, and w to the other.

After this step, at most one node does not have degree Δ yet, and misses at most one edge. If this case occurs, Δ must be odd (otherwise, v would be the only node with odd degree, while the number of nodes with odd degree in any graph must be even). We complete the procedure by adding a copy of $K_{\Delta, \Delta-1}$, connecting v to one of the Δ nodes of degree $\Delta - 1$ in $K_{\Delta, \Delta-1}$, and finally adding a perfect matching between the remaining nodes of degree $\Delta - 1$ (whose number is even). The resulting graph H is a Δ -regular supergraph of G with $|V(H)| \leq |V(G)| + 4\Delta - 1$ nodes. \square

Next, we ensure that Δ -regular graphs of girth $2k + 1$ without too many nodes exist:

LEMMA 4.6 (Δ -REGULAR GRAPHS WITH PRESCRIBED GIRTH AND ORDER [10]). *For $\Delta \geq 2 \in \mathbb{N}$ and $g \geq 3 \in \mathbb{N}$, there exist Δ -regular graphs with girth at least g and $2m$ nodes for each $m \geq 2 \cdot \sum_{i=0}^{g-2} (\Delta - 1)^i$.*

PROOF. Fix g . The claim trivially holds for $\Delta = 2$, as any cycle of length $2m$ satisfies the requirements. Now assume that the claim holds for some $\Delta \geq 2$. Thus, for any $m \geq 2 \cdot \sum_{i=0}^{g-2} \Delta^i$, there exists a Δ -regular graph G with $2m \geq 4 \cdot \sum_{i=0}^{g-2} (\Delta - 1)^i$ nodes and girth at least g . Now let G' be a graph satisfying the following conditions:

- (1) $|V(G')| = 2m$,
- (2) $\Delta \leq \delta(v) \leq \Delta + 1$ for all nodes $v \in V(G')$,
- (3) G' has girth at least g , and
- (4) $|E(G')|$ is maximal among all graphs (including G) that satisfy the other three conditions.

We show that G' is $(\Delta + 1)$ -regular. To this end, assume towards a contradiction that G' is *not* $(\Delta + 1)$ -regular. Then either G' has exactly one node with degree Δ or G' has at least two nodes v' and w' with degree Δ .

The first case cannot occur because it would require G' to have exactly one node of odd degree for $\Delta + 1$ even, and exactly $2m - 1$ nodes of odd degree for $\Delta + 1$ odd, contradicting the fact that in any graph, the number of nodes with odd degree must be even. So assume that there are at least two nodes v' and w' with degree Δ in G' . Observe that all nodes of degree Δ must lie within distance $g - 2$ of v' and w' , i.e., in $N := \Gamma^{g-2}(v') \cup \Gamma^{g-2}(w')$, as otherwise we could add an edge to G' without violating the first three properties, contradicting the fourth property. Since $|\Gamma^j(v)| \leq \sum_{i=0}^j \Delta^i$ for any node $v \in V(G')$ with $\delta(v) = \Delta$, we have $|N| \leq m$, and consequently, $|N| \leq |V(G')| - |N|$.

Now let $\{x, y\}$ be an edge between two nodes $x, y \in V(G') \setminus N$. We know such an edge must exist, because otherwise $(\Delta + 1) \cdot (|V(G')| - |N|)$ edges would need to run between nodes in $V(G') \setminus N$ and nodes in N , which would force $\delta(v) = \Delta + 1$ for all $v \in N$, contradicting the fact that $\delta(v') = \delta(w') = \Delta$. But then \bar{G}' with $V(\bar{G}') := V(G')$ and $E(\bar{G}') := (E(G') \setminus \{x, y\}) \cup \{\{x, v\}, \{y, w\}\}$ is a graph with more edges than G' that satisfies the first three requirements, contradicting the maximality of G' . Therefore, no node with degree Δ can exist in G' , i.e., G' must be $(\Delta + 1)$ -regular. \square

COROLLARY 4.7 (EXISTENCE OF H'_k AND H_k). *There exists a Δ -regular supergraph H'_k of G'_k with $O(|V(G'_k)|)$ nodes, and for $\Delta \geq 2$ and $g \geq 3$, there exists a Δ -regular graph H_k with girth $g = 2k + 1$ and $O(\Delta^{2k})$ nodes.*

PROOF. The existence of H'_k follows from Lemma 4.5 (p. 13) as a special case. The existence of H_k follows from Lemma 4.6 (p. 14) as a special case, noting that $4 \cdot \sum_{i=0}^{(2k+1)-2} \Delta^i = 4 \cdot \frac{\Delta^{2k}-1}{\Delta-1} \leq 4 \cdot \Delta^{2k} \in \mathcal{O}(\Delta^{2k})$. \square

4.3 High-Girth Cluster Tree Graphs

Our final tool allows us to construct small common lifts of regular graphs:

LEMMA 4.8 (COMMON LIFTS OF Δ -REGULAR GRAPHS [2]). *Let H and H' be two Δ -regular graphs. Then there exists a graph \tilde{H} that is a lift of H and H' s.t. $|V(\tilde{H})| \leq 4|V(H)||V(H')|$.*

PROOF. By Hall's Theorem [16, 17], any regular bipartite graph has a perfect matching, and the edge set of a Δ -regular bipartite graph can be partitioned into Δ perfect matchings. For the special case that H and H' are both bipartite, let M_1, \dots, M_Δ and M'_1, \dots, M'_Δ be partitions of their respective edge sets into perfect matchings. We define \tilde{H} with

$$V(\tilde{H}) = V(H) \times V(H') \quad \text{and} \quad E(\tilde{H}) = \{(v, w), (v', w') \mid \exists i \in [\Delta]: \{v, v'\} \in M_i \wedge \{w, w'\} \in M'_i\}.$$

\tilde{H} has $|V(H)||V(H')|$ nodes, and for each $(v, w) \in V(\tilde{H})$ and $i \in [\Delta]$, there are unique $\{v, v'\} \in M_i$ and $\{w, w'\} \in M'_i$. Hence, (v, w) has Δ neighbors, and if these neighbors are $(v_1, w_1), \dots, (v_\Delta, w_\Delta)$, the neighbors of v in H are v_1, \dots, v_Δ , while the neighbors of w in H' are w_1, \dots, w_Δ . Therefore, \tilde{H} is a lift of H via $\phi_H: V(\tilde{H}) \rightarrow V(H)$ with $\phi_H((v, w)) = v$, and a lift of H' via $\phi_{H'}: V(\tilde{H}) \rightarrow V(H')$ with $\phi_{H'}((v, w)) = w$.

If a graph is not bipartite, we construct its canonical double cover, i.e., its tensor product with K_2 , to obtain a bipartite regular graph, with which we proceed as described above. The canonical double cover has twice as many nodes as the original graph, and in the worst case, we need it for H and H' , so $|V(\tilde{H})| \leq 4|V(H)||V(H')|$. Furthermore, if χ_H is covering map of the canonical double cover C of H , then \tilde{H} is a lift of H via $\phi_C \circ \chi_H$; analogously, \tilde{H} is a lift of H' . \square

COROLLARY 4.9 (EXISTENCE OF \tilde{H}_k). *There exists a Δ -regular common lift \tilde{H}_k of H_k and H'_k with girth $g \geq 2k + 1$ and $\mathcal{O}(\beta^{2k^2+4k+1})$ nodes.*

PROOF. Recall that we start with G'_k as specified in Definition 4.3 (p. 13), parametrized by $\beta \geq 2k + 1$. By Lemma 3.6 (p. 8), G'_k has maximum degree $\Delta = \beta^{k+1}$, and by Lemma 3.5 (p. 8), G'_k has order $n < |V(C_0)| \left(\frac{\beta}{\beta-(k+1)}\right) \leq 2|V(C_0)| = 2\beta^{2k+1}$. We apply Lemma 4.5 (p.13) to obtain a Δ -regular supergraph H'_k of G'_k with $\mathcal{O}(\beta^{2k+1})$ nodes. By Corollary 4.7 (p. 14), there also exists a Δ -regular graph H_k with girth $\geq 2k + 1$ and $|V(H_k)| \in \mathcal{O}(\Delta^{2k}) = \mathcal{O}(\beta^{2k^2+2k})$. Therefore, from Lemma 4.8 (p. 15) along with the observation that lifting cannot decrease girth, we can infer the existence of a graph \tilde{H}_k which is a lift of H_k and H'_k , has girth at least $2k + 1$, and satisfies $|V(\tilde{H}_k)| \leq 4|V(H_k)||V(H'_k)| \in \mathcal{O}(\beta^{2k^2+4k+1})$. \square

Finally, we construct G_k as a subgraph of \tilde{H}_k :

THEOREM 4.10 (EXISTENCE OF G_k [21]). *There exists a graph G_k of girth $g \geq 2k + 1$ with $\mathcal{O}(\beta^{2k^2+4k+1})$ nodes that conforms with CT_k .*

PROOF. By Corollary 4.9 (p. 15), there exists a graph \tilde{H}_k with girth $g \geq 2k + 1$ and $\mathcal{O}(\beta^{2k^2+4k+1})$ nodes that is a common lift of H'_k and H_k . Now let ψ_1 be a covering map from \tilde{H}_k to H'_k . We construct G_k as a subgraph of \tilde{H}_k with

$$V(G_k) := \{v \in \tilde{H}_k \mid \psi_1(v) \in G'_k\} \quad \text{and} \quad E(G_k) := \{(v, w) \mid v, w \in V(\tilde{H}_k) \wedge \{\psi_1(v), \psi_1(w)\} \in E(G'_k)\}.$$

Then $\phi := \psi_1|_{V(G_k)}$ is a covering map from G_k to G'_k . To see that G_k conforms with CT_k , observe that ϕ is indeed a bijection on node neighborhoods, and set $C(v) := C(\phi(v))$ for $v \in V(G_k)$. Hence, we can conclude that G_k is an $\mathcal{O}(\beta^{2k^2+4k+1})$ -node graph of girth $g \geq 2k + 1$ (inherited from \tilde{H}_k), conforming to CT_k (inherited from G'_k). \square

5 LOWER BOUND ON MINIMUM VERTEX COVER APPROXIMATION

Definition 5.1 (Vertex cover). Given a finite, simple graph $G = (V, E)$, a *vertex cover* is a node subset $W \subseteq V$ meeting all edges, i.e., for each $\{v, w\} \in E$, $v \in W$ or $w \in W$. A *Minimum Vertex Cover (MVC)* is a vertex cover of minimum cardinality, and an α -approximate MVC is a vertex cover that is at most factor α larger than an MVC.

We begin by bounding the size of an MVC of any CT graph G_k . To this end, recall that n_0 is the number of nodes in C_0 , which we have shown to contain a large fraction of all nodes.

LEMMA 5.2 (SIZE OF AN MVC OF G_k). *The size of an MVC of G_k is at most $n - n_0$, i.e., $|MVC| \leq n - n_0$.*

PROOF. As C_0 is an independent set, i.e., for $v, w \in V(C_0)$, $\{v, w\} \notin E(G_k)$, $V(G_k) \setminus V(C_0)$ is a vertex cover. \square

Due to the indistinguishability of nodes in C_0 and C_1 in G_k (Theorem 3.7, p. 8), we obtain the following requirement for the behavior of any k -round distributed algorithm:

LEMMA 5.3 (SIZE OF A COMPUTED VERTEX COVER). *On a CT graph G_k of girth at least $2k + 1$ with uniformly random node identifiers, in the worst case (in expectation), a k -round deterministic (randomized) MVC algorithm in the LOCAL model must select at least $\frac{n_0}{2}$ nodes.*

PROOF. Recall that a k -round LOCAL algorithm is a function f mapping k -hop subgraphs labeled by inputs, node identifiers, and, in case of a randomized algorithm, strings of unbiased independent random bits to outputs. Noting that the vertex cover task has no inputs, by Theorem 3.7 (p. 8), nodes in C_0 and C_1 are k -hop indistinguishable. Hence, restricting f to the k -hop subgraphs of nodes in $V(C_0) \cup V(C_1)$, we get a function depending only on the node identifiers and random strings observed up to distance k in the (isomorphic) trees that constitute the k -hop subgraphs.

With this in mind, assign the node identifiers uniformly at random (from the feasible range, drawn without repetition). By the above observations, the output of each node $v \in V(C_0) \cup V(C_1)$ now depends on the random labeling of its k -hop subgraph only, which is drawn from the same distribution for each node. Thus, there is some $p \in [0, 1]$ such that for each $v \in V(C_0) \cup V(C_1)$, the probability that v enters the vertex cover computed by the algorithm equals p .

Now consider $v \in V(C_0)$. By the construction of G_k , there is some edge $\{v, w\} \in E(G_k)$ such that $w \in V(C_1)$. Because v or w must be in the vertex cover the algorithm computes, we have that $1 = P[v \text{ or } w \text{ are in the vertex cover}] \leq 2p$. By linearity of expectation, we conclude that the expected size of the vertex cover is at least $p|V(C_0) \cup V(C_1)| \geq \frac{n_0}{2}$. \square

Choosing β appropriately, we can plug all statements together to arrive at the desired MVC lower bound:

THEOREM 5.4 (MVC LOWER BOUND). *In the family of graphs with at most n nodes and degrees of at most Δ , the worst-case (expected) approximation ratio α of a deterministic (randomized) k -round MVC algorithm in the LOCAL model satisfies $\alpha \in \min \{n^{\Omega(1/(k^2 \log k))}, \Delta^{\Omega(1/(k \log k))}\}$. In particular, achieving an (expected) polylogarithmic approximation ratio $\alpha \in \log^{O(1)} \min \{n, \Delta\}$ requires $k \in \Omega(\min \{\sqrt{\log n / \log \log n}, \log \Delta / \log \log \Delta\})$ communication rounds.*

PROOF. Given any $\alpha > 1$, fix $\beta := 4(k+1)\alpha$. By Theorem 4.10 (p. 15), CT graphs of girth $2k+1$ with $O(\beta^{2k^2+4k+1}) \subseteq O(k^2(\log k + \log \alpha))$ nodes exists, which by Lemma 3.6 (p. 8) have maximum degree $\Delta = \beta^{k+1} \in 2^{O(k(\log k + \log \alpha))}$. Requiring that the number of nodes is at most n and the maximum degree is at most Δ , solving for α yields that

$$\alpha \leq 2^{ck^{-2} \log n - \log k} \quad \text{and} \quad \alpha \leq 2^{ck^{-1} \log \Delta - \log k},$$

respectively, where $c > 0$ is a sufficiently small constant. For $k \leq \frac{c}{2} \cdot \min \{\sqrt{\log n / \log \log n}, \log \Delta / \log \log \Delta\}$, the $\log k$ terms are dominated and the constraints are met for $\alpha \in \min \{n^{\Omega(1/(k^2 \log k))}, \Delta^{\Omega(1/(k \log k))}\}$.

Choosing $k \in \omega \left(\min \left\{ \sqrt{\log n / \log \log n}, \log \Delta / \log \log \Delta \right\} \right)$ makes $\alpha = \min \{ \log^{\omega(1)} n, \log^{\omega(1)} \Delta \}$ feasible. Hence, if we can show that for any (feasible) choice of α and graph G_k conforming to CT_k for parameter $\beta = 4(k+1)\alpha$ and girth $2k+1$, any algorithm in the LOCAL model has approximation ratio at least α in the worst case (in expectation), the claim of the theorem follows. To see this, note that G_k contains a vertex cover of size $n-n_0$ by Lemma 5.2 (p. 16) and any k -round algorithm selects at least $\frac{n_0}{2}$ nodes (in expectation) under uniformly random node identifiers by Lemma 5.3 (p. 16). By Lemma 3.5 (p. 8), this results in an (expected) approximation ratio of at least $\frac{n_0}{2(n-n_0)} \geq \frac{\beta}{4(k+1)} = \alpha$. \square

REFERENCES

- [1] AKIYAMA, J., ERA, H., AND HARARY, F. Regular graphs containing a given graph. *Elemente der Mathematik* 38 (1983), 15–17.
- [2] ANGLUIN, D., AND GARDINER, A. Finite common coverings of pairs of regular graphs. *Journal of Combinatorial Theory, Series B* 30, 2 (1981), 184–187.
- [3] BALLIU, A., BRANDT, S., HIRVONEN, J., OLIVETTI, D., RABIE, M., AND SUOMELA, J. Lower bounds for maximal matchings and maximal independent sets. In *60th IEEE Annual Symposium on Foundations of Computer Science, FOCS 2019, Baltimore, Maryland, USA, November 9-12, 2019* (2019), pp. 481–497.
- [4] BALLIU, A., HIRVONEN, J., KORHONEN, J. H., LEMPIÄINEN, T., OLIVETTI, D., AND SUOMELA, J. New classes of distributed time complexity. In *Proceedings of the 50th Annual ACM SIGACT Symposium on Theory of Computing* (New York, NY, USA, 2018), STOC 2018, ACM, pp. 1307–1318.
- [5] BAR-YEHUDA, R., CENSOR-HILLEL, K., GHAFARI, M., AND SCHWARTZMAN, G. Distributed approximation of maximum independent set and maximum matching. In *Proceedings of the ACM Symposium on Principles of Distributed Computing* (New York, NY, USA, 2017), PODC '17, ACM, pp. 165–174.
- [6] BAR-YEHUDA, R., CENSOR-HILLEL, K., AND SCHWARTZMAN, G. A distributed $(2+\epsilon)$ -approximation for vertex cover in $O(\log \Delta / \epsilon \log \log \Delta)$ rounds. In *Proceedings of the 2016 ACM Symposium on Principles of Distributed Computing* (New York, NY, USA, 2016), PODC '16, ACM, pp. 3–8.
- [7] BRANDT, S., FISCHER, O., HIRVONEN, J., KELLER, B., LEMPIÄINEN, T., RYBICKI, J., SUOMELA, J., AND UITTO, J. A lower bound for the distributed Lovász local lemma. In *Proceedings of the Forty-Eighth Annual ACM Symposium on Theory of Computing* (New York, NY, USA, 2016), STOC '16, Association for Computing Machinery, p. 479–488.
- [8] CHANG, Y., HE, Q., LI, W., PETTIE, S., AND UITTO, J. The complexity of distributed edge coloring with small palettes. In *Proceedings of the Twenty-Ninth Annual ACM-SIAM Symposium on Discrete Algorithms, SODA 2018, New Orleans, LA, USA, January 7-10, 2018* (2018), pp. 2633–2652.
- [9] CZYGRINOW, A., HAŃKOWIAK, M., AND WAWRZYŃIAK, W. Fast distributed approximations in planar graphs. In *Proceedings of the 22nd International Symposium on Distributed Computing* (Berlin, Heidelberg, 2008), DISC '08, Springer-Verlag, p. 78–92.
- [10] ERDŐS, P., AND SACHS, H. Reguläre graphen gegebener taillenweite mit minimaler knotenzahl. *Wiss. Z. Martin-Luther-Univ. Halle-Wittenberg Math.-Natur. Reihe* 12, 3 (1963), 251–257.
- [11] FEUILLOLEY, L., FRAIGNAUD, P., AND HIRVONEN, J. A Hierarchy of Local Decision. In *43rd International Colloquium on Automata, Languages, and Programming (ICALP 2016)* (Dagstuhl, Germany, 2016), I. Chatzigiannakis, M. Mitzenmacher, Y. Rabani, and D. Sangiorgi, Eds., vol. 55 of *Leibniz International Proceedings in Informatics (LIPIcs)*, Schloss Dagstuhl–Leibniz-Zentrum fuer Informatik, pp. 118:1–118:15.
- [12] FRAIGNAUD, P., KORMAN, A., AND PELEG, D. Towards a complexity theory for local distributed computing. *J. ACM* 60, 5 (Oct. 2013), 35:1–35:26.
- [13] GHAFARI, M., KUHN, F., AND MAUS, Y. On the complexity of local distributed graph problems. In *Proceedings of the 49th Annual ACM SIGACT Symposium on Theory of Computing* (New York, NY, USA, 2017), STOC 2017, ACM, pp. 784–797.
- [14] GÖÖS, M., HIRVONEN, J., AND SUOMELA, J. Lower bounds for local approximation. *J. ACM* 60, 5 (Oct. 2013), 39:1–39:23.
- [15] GÖÖS, M., HIRVONEN, J., AND SUOMELA, J. Linear-in- Δ lower bounds in the local model. *Distributed Computing* 30, 5 (2017), 325–338.
- [16] HALL, P. On representatives of subsets. *Journal of the London Mathematical Society s1-10*, 1 (1935), 26–30.
- [17] KÖNIG, D. Über graphen und ihre anwendung auf determinantentheorie und mengenlehre. *Mathematische Annalen* 77, 4 (Dec 1916), 453–465.
- [18] KUHN, F., MOSCIBRODA, T., AND WATTENHOFER, R. What cannot be computed locally! In *Proceedings of the Twenty-third Annual ACM Symposium on Principles of Distributed Computing* (New York, NY, USA, 2004), PODC '04, ACM, pp. 300–309.
- [19] KUHN, F., MOSCIBRODA, T., AND WATTENHOFER, R. The price of being near-sighted. In *Proceedings of the Seventeenth Annual ACM-SIAM Symposium on Discrete Algorithms* (Philadelphia, PA, USA, 2006), SODA '06, Society for Industrial and Applied Mathematics, pp. 980–989.
- [20] KUHN, F., MOSCIBRODA, T., AND WATTENHOFER, R. Local computation: Lower and upper bounds. *CoRR abs/1011.5470* (2010).
- [21] KUHN, F., MOSCIBRODA, T., AND WATTENHOFER, R. Local computation: Lower and upper bounds. *J. ACM* 63, 2 (Mar. 2016), 17:1–17:44.
- [22] LAURINHARJU, J., AND SUOMELA, J. Brief announcement: Linial's lower bound made easy. In *Proceedings of the 2014 ACM Symposium on Principles of Distributed Computing* (New York, NY, USA, 2014), PODC '14, Association for Computing Machinery, p. 377–378.
- [23] LENZEN, C., AND WATTENHOFER, R. Leveraging linial's locality limit. In *Proceedings of the 22nd International Symposium on Distributed Computing* (Berlin, Heidelberg, 2008), DISC '08, Springer-Verlag, p. 394–407.
- [24] LINIAL, N. Locality in distributed graph algorithms. *SIAM Journal on Computing* 21, 1 (1992), 193–201.
- [25] NAOR, M., AND STOCKMEYER, L. What can be computed locally? *SIAM J. Comput.* 24, 6 (Dec. 1995), 1259–1277.
- [26] PANCONESI, A., AND RIZZI, R. Some simple distributed algorithms for sparse networks. *Distrib. Comput.* 14, 2 (Apr. 2001), 97–100.
- [27] PELEG, D. *Distributed Computing: A Locality-Sensitive Approach*. Society for Industrial and Applied Mathematics, Philadelphia, PA, 2000.
- [28] SUOMELA, J. Survey of local algorithms. *ACM Comput. Surv.* 45, 2 (Mar. 2013), 24:1–24:40.

[29] SUOMELA, J. Distributed algorithms (online textbook), 2019.

A FURTHER LOWER BOUNDS

Definition A.1 (Fundamental graph problems). Given a finite, simple graph $G = (V, E)$,

- **Minimum Vertex Cover (MVC)** ... find a minimum vertex subset $S \subseteq V$ s.t. $\forall \{u, v\} \in E: u \in S \vee v \in S$.
- **Minimum Dominating Set (MDS)** ... find a minimum vertex subset $S \subseteq V$ s.t. $\forall v \in V: v \in S \vee \exists u \in S: \{u, v\} \in E$.
- **Maximum Matching (MaxM)** ... find a maximum edge subset $T \subseteq E$ s.t. $\forall e_1, e_2 \in T: e_1 \cap e_2 = \emptyset$.
- **Maximal Matching (MM)** ... find an inclusion-maximal edge subset $T \subseteq E$ s.t. $\forall e_1, e_2 \in T: e_1 \cap e_2 = \emptyset$.
- **Maximal Independent Set (MIS)** ... find an inclusion-maximal vertex subset $S \subseteq V$ s.t. $\forall u, v \in S: \{u, v\} \notin E$.

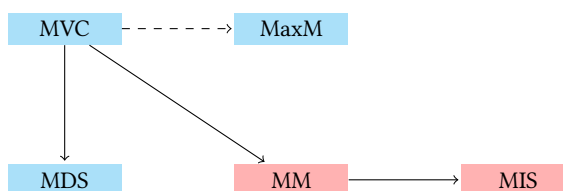

Fig. 5. Relationships between the lower bounds derived for fundamental graph problems (adapted from [21]). Optimization problems marked blue; binary problems marked red. Solid arrows indicate reductions; dashed arrows indicate analogy.

A.1 Minimum Dominating Set (MDS)

THEOREM A.2 (MDS LOWER BOUND). *The best approximation ratio a k -round deterministic (randomized) MDS algorithm in the LOCAL model can achieve is $\alpha \in n^{\Omega(1/k^2)}/k$ and $\alpha \in \Omega(\Delta^{\frac{1}{k+1}}/k)$. Hence, to obtain an approximation ratio polylogarithmic in n or Δ , in the worst case (in expectation) an algorithm needs to run for $k \in \Omega(\sqrt{\log n / \log \log n})$ or $k \in \Omega(\log \Delta / \log \log \Delta)$ rounds, respectively.*

PROOF. Observe that a vertex cover VC of any graph G can be transformed into a dominating set DS of its line graph $L(G)$ without increasing its cardinality by adding one edge $\{v, w\} \in V(L(G))$ for every node $v \in V(G)$. Similarly, a dominating set of $L(G)$ can be turned into a vertex cover of G by adding the nodes v, w for all $\{v, w\} \in DS(L(G))$, at most doubling its size. Therefore, in general, MVC and MDS are equivalent up to a factor of two in the approximation ratio. Now consider a CT graph G_k and its line graph $L(G_k)$. In the LOCAL model of computation, a k -round computation on the line graph can be simulated in $k+1$ rounds on the original graph, i.e., G_k and $L(G_k)$ have the same locality properties. Hence, up to a factor of two in the approximation ratio, MVC and MDS are equivalent also in our computational model. The stated bounds hence follow analogously to Theorem 5.4 (p. 16). \square

A.2 Maximum Matching (MaxM)

Here, we are dealing with a packing problem, rather than a covering problem, and we are asked to select edges, rather than nodes. Therefore, instead of using a reduction from MVC, we amend the CT graph construction to allow for *edge indistinguishability* arguments:

Definition A.3 (k -hop edge indistinguishability). Two edges $\{v, w\}$ and $\{v', w'\}$ are k -hop indistinguishable if it holds that $G^k(\{v, w\}) := G^k(\{v\}) \cup G^k(\{w\}) \cong G^k(\{v'\}) \cup G^k(\{w'\}) =: G^k(\{v', w'\})$.

THEOREM A.4 (MAXM LOWER BOUND). *The best approximation ratio a k -round deterministic (randomized) MaxM algorithm in the LOCAL model can achieve is $\alpha \in n^{\Omega(1/k^2)}/k$ and $\alpha \in \Omega(\Delta^{\frac{1}{k+1}}/k)$. Hence, to obtain an approximation ratio polylogarithmic in n or Δ , in the worst case (in expectation) an algorithm needs to run for $k \in \Omega(\sqrt{\log n / \log \log n})$ or $k \in \Omega(\log \Delta / \log \log \Delta)$ rounds, respectively.*

PROOF. We create a hard graph H_k from two copies of G_k (G_k and \bar{G}_k) by adding a perfect matching to connect each node from G_k with its counterpart in \bar{G}_k .⁹ Now, in addition to the neighbors in G_k , each node has $1 = \beta^0$ neighbors in the copy of its own cluster in \bar{G}_k . Figure 6 (p. 19) illustrates the construction.

Since G_k and \bar{G}_k are CT graphs, all nodes in the clusters C_0, \bar{C}_0, C_1 , and \bar{C}_1 had isomorphic k -hop subgraphs before the matching was added. As the edges from the matching connect each node from G_k precisely with its counterpart in \bar{G}_k , and both graphs have girth $\geq 2(k+1)$, adding the matching cannot break symmetry, so all nodes in the clusters C_0, \bar{C}_0, C_1 , and \bar{C}_1 have isomorphic k -hop subgraphs in H_k as well. From the definition of edge indistinguishability, it

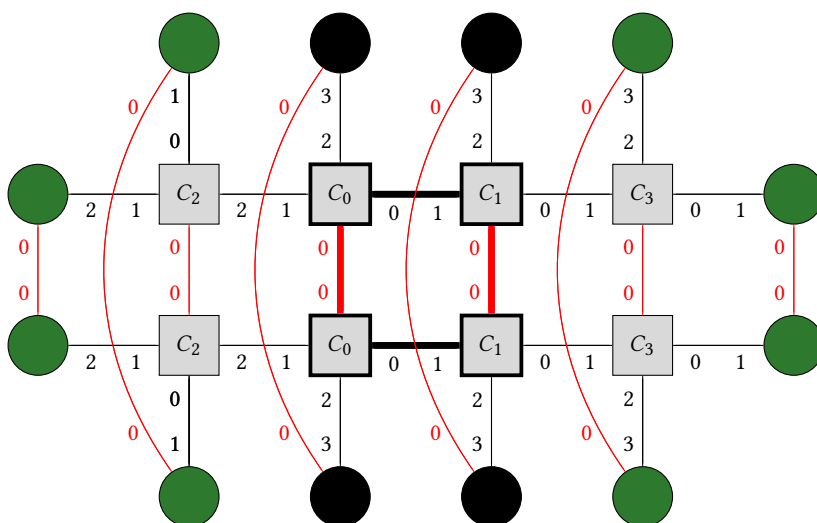

Fig. 6. Construction of H_2 from two copies of G_2 ; perfect matching marked red. The edges represented by the thickened lines are 2-hop indistinguishable.

is clear that for $v \in C_0$ and $w \in C_1$ with $\{v, w\} \in E(G_k)$, the edges $\{v, w\}$, $\{v, \bar{v}\}$, $\{w, \bar{w}\}$, and $\{\bar{v}, \bar{w}\}$ have isomorphic k -hop subgraphs (we could again define an algorithm analogous to Algorithm 1, p. 9, to construct the isomorphism explicitly). It follows that the edges running between C_0 and C_1 (\bar{C}_0 and \bar{C}_1) are indistinguishable from the edges running between C_0 and \bar{C}_0 (C_1 and \bar{C}_1).

Now consider a node $v \in C_0$ and the set E_v of $\beta + 1$ pairwise indistinguishable edges that have v as an endpoint. To guarantee a valid matching, a deterministic algorithm operating on a labeling chosen uniformly at random must ensure $\sum_{e \in E_v} p(e) \leq 1$, so each edge e (including the edge running from v to $v' \in \bar{C}_0$) must be selected into the matching with probability $p(e) \leq \frac{1}{\beta+1}$. Consequently, the expected number of edges contributed to the matching by edges running between C_0 and \bar{C}_0 is $\mathbb{E}[|M(C_0, \bar{C}_0)_D|] \leq \frac{n_0}{\beta+1}$ by linearity of expectation. To obtain a feasible matching,

⁹This idea appears already in [19], but the construction differs from the one presented here in that all powers of β are shifted by one, e.g., nodes in C_0 have β^1 , rather than β^0 , neighbors in C_1 .

the number of edges in the matching without an endpoint in $C_0 \cup \bar{C}_0$ can be at most $2n - 2n_0$, where $n := |V(G_k)|$ and $n_0 := |V(C_0)|$. It follows that there exists at least one labeling for which a k -round deterministic algorithm produces a matching with

$$|M_D| \leq \frac{n_0}{\beta + 1} + 2n - 2n_0 \leq n_0 \cdot \frac{4(k+1) + 1}{\beta} \in O\left(n \cdot \frac{k}{\beta}\right),$$

where in the second to last step we applied Lemma 3.5 (p. 8) to bound $n - n_0$. With $\mathbb{E}[|M_R|] \leq \mathbb{E}[|M_D|]$ from Yao's principle, the bound generalizes to k -round randomized algorithms.

To see that this enforces the approximation ratios stated above, observe that the maximum matching for H_k has cardinality n by construction, i.e., $\alpha \in \Omega\left(\frac{\beta}{k}\right)$. The trade-offs between running time and approximation ratio in terms of n and Δ now follow analogously to the proof of Theorem 5.4 (p. 16), noting that the increase of factor 2 in the number of nodes and additive 1 in node degrees has no asymptotic effect. \square

A.3 Maximal Matching (MM)

We start by establishing the lower bound in the deterministic setting by exploiting the relationship between MM and MVC:

THEOREM A.5 (MM LOWER BOUND FOR DETERMINISTIC ALGORITHMS). *Any deterministic MM algorithm needs to run for $k \in \Omega(\min\{\sqrt{\log n/\log \log n}, \log \Delta/\log \log \Delta\})$ in the worst case.*

PROOF. Since taking the endpoints of a maximal matching yields a 2-approximation of MVC, the claim follows immediately from the bounds established in Theorem 5.4 (p. 16). \square

For the randomized setting, we do not obtain the same bounds as in Theorem 5.4 (p. 16) immediately. The reason is that randomized algorithms for binary problems lend themselves to Las Vegas algorithms, whereas randomized algorithms for optimization problems lend themselves to Monte Carlo algorithms. We establish the bounds for the randomized setting by showing how a randomized MM algorithm that operates in T rounds in expectation can be used to compute an $O(1)$ approximation in expectation for MVC in $2T + 2$ rounds:

THEOREM A.6 (MM LOWER BOUND FOR RANDOMIZED ALGORITHMS). *In expectation, to find a solution, any randomized MM algorithm needs to run for $k \in \Omega(\sqrt{\log n/\log \log n})$ and $k \in \Omega(\log \Delta/\log \log \Delta)$ rounds.*

PROOF. Let \mathcal{A}_M be an MM algorithm with expected time complexity T , running on some graph $G = (V, E)$ with maximum degree Δ . The following MVC approximation algorithm \mathcal{A}_{VC} runs with fixed time complexity $2T + 2$:

- (1) For a sufficiently large constant c , execute $c \ln \Delta$ independent runs i of the following in parallel:
 - (a) All nodes simulate \mathcal{A}_M for $2T$ rounds.
 - (b) If E_M is the edge set selected after these rounds, every node that is incident with more than one selected edge removes *all* selected incident edges from E_M in an additional round of communication.
 - (c) All nodes (locally) output the endpoints of all edges remaining in E_M as $V'_{VC,i}$.
- (2) Define $x_v := 6 \cdot \frac{|\{i | v \in V'_{VC,i}\}|}{c \ln \Delta}$, and set $V_{VC} := \{v \in V \mid x_v \geq 1\}$.
- (3) All nodes communicate whether they are in V_{VC} , and nodes with a remaining uncovered edge join V_{VC} .

The final step ensures that the algorithm returns a vertex cover.

To see that not too many nodes are selected in expectation, observe first that by construction, $V'_{VC,i}$ is a matching for each i . Therefore, we have that

$$\sum_{v \in V(G)} x_v \leq 6 \cdot 2 \cdot |MVC|,$$

where MVC is a minimum vertex cover. As only nodes with $x_v \geq 1$ are selected in Step 2, the total number of nodes selected in this step is (deterministically) at most $12 \cdot |MVC|$.

It remains to bound the expected number of nodes selected in Step 3. To this end, observe that by Markov's bound, each independent run of \mathcal{A}_M yields a maximal matching with probability $\geq \frac{1}{2}$, and hence, each $V'_{VC,i}$ forms a VC with that same probability. Whenever this is the case, $V'_{VC,i}$ contains at least one endpoint of each edge $\{v, w\} \in E$. Hence, if at least one third of all runs are successful, we have $x_v + x_w \geq 2$ for all edges $\{v, w\} \in E$, and V_{VC} is a vertex cover already at the end of Step 2. Letting X be sum of the independent and identically distributed Bernoulli variables X_i indicating whether run i is successful, we have $\mathbb{E}[X] \geq \frac{c \ln \Delta}{2}$. Using a Chernoff bound, we can then bound the probability to have less than $\frac{c \ln \Delta}{3}$ runs in which $V'_{VC,i}$ forms a VC as

$$\mathbb{P}\left[X < \frac{c \ln \Delta}{3}\right] \leq \mathbb{P}\left[X \leq \left(1 - \frac{1}{3}\right) \frac{c \ln \Delta}{2}\right] \leq e^{-\frac{(\frac{1}{3})^2 \cdot c \ln \Delta}{4}} = e^{-\frac{c \ln \Delta}{36}} = \frac{1}{\Delta^{\frac{c}{36}}}.$$

Hence, for $c \geq 36$, the probability that V_{VC} is not a VC after Step 2 is $\leq \frac{1}{\Delta}$. Therefore, with probability at least $1 - 1/\Delta$, no further nodes are added in Step 3 of the algorithm. Otherwise, i.e., with probability at most $1/\Delta$, we add no more than $2|E(G)|$ nodes. Given that any vertex cover must contain at least $|E(G)|/\Delta$ nodes, we conclude that the expected size of the VC computed via the procedure described above is at most

$$12 \cdot |MVC| + \frac{1}{\Delta} \cdot 2\Delta \cdot |MVC| = 14 \cdot |MVC|.$$

Thus, a randomized MM algorithm beating the stated bounds would imply an MVC algorithm beating the bounds from Theorem 5.4 (p. 16). Since such an MVC algorithm cannot exist, the stated bounds must hold.¹⁰ \square

A.4 Maximal Independent Set (MIS)

We establish our last lower bound via reduction from MM:

THEOREM A.7 (MIS LOWER BOUND). *In the worst case (in expectation), to find a solution, any deterministic (randomized) MIS algorithm needs to run for $k \in \Omega(\sqrt{\log n / \log \log n})$ or $k \in \Omega(\log \Delta / \log \log \Delta)$ rounds.*

PROOF. Observe that an MM of G_k is an MIS of the line graph $L(G_k)$, and that a k -round MIS computation on $L(G_k)$ can be simulated in $k + 1$ rounds on G_k . Furthermore, $n_{L(G_k)} \leq n_{G_k}^2/2$, and $\Delta_{L(G_k)} \leq 2\Delta_{G_k}$. As $\log n \in \Theta(\log(n^2/2))$, an MIS algorithm beating the stated bounds on $L(G_k)$ would imply an MM algorithm beating the bounds from Theorems A.5 or A.6 (pp. 20 et seq.). It follows that the stated bounds must hold also for MIS. \square

¹⁰In [21], the size of the VC computed in Step 2 is bounded as $\leq 10 \cdot |MVC|$ without explanation, and an expected VC size of $\leq 11 \cdot |MVC|$ is derived.