

# Towards Secure Over-The-Air Computation

Matthias Frey\*, Igor Bjelaković† and Sławomir Stańczak\*†

\*Technische Universität Berlin, Germany and †Fraunhofer Heinrich Hertz Institute, Berlin, Germany

**Abstract**—We propose a new method to protect Over-The-Air (OTA) computation schemes against passive eavesdropping. Our method uses a friendly jammer whose signal is – contrary to common intuition – stronger at the legitimate receiver than it is at the eavesdropper. It works for a large class of analog OTA computation schemes and we give details on the special case of computing an arithmetic average over an AWGN channel. The derived secrecy guarantee translates to a lower bound on the eavesdropper’s mean square error while the question of how to provide operationally more significant guarantees such as semantic security remains open for future work. The key ingredients in proving the security guarantees are a known result on channel resolvability and a generalization of existing achievability results on coding for compound channels.

## I. INTRODUCTION

In many envisioned applications in wireless networks, the receiver requires only a function of values available at the distributed transmitters rather than the full information about the values themselves. Examples include distributed Federated Learning [2] and distributed anomaly detection in sensor networks [3]. In such cases, analog OTA computation schemes can deliver sizable performance gains over classical separation-based approaches especially when the number of transmitters is large [2]–[7].

In some of the foreseen scenarios, such as e-health or industrial applications, security and privacy are expected to be major concerns in addition to efficient resource usage. Information theoretic secrecy can complement classic cryptography in addressing these issues. A natural way to enhance security in a setting such as in [4] is to add a jammer to the system that deteriorates the signal-to-noise ratio (SNR) of the eavesdropper and thereby prevents it from reconstructing a low-noise estimate of the objective function. In this case, it is necessary to place the jammer so that its signal is significantly stronger at the eavesdropper than it is at the legitimate receiver. Since in general, the exact position of an eavesdropper is not known, jammers typically have to be placed at multiple locations. In this work, we propose to turn this situation around and place the jammer so that its signal is stronger at the legitimate receiver than it is at the eavesdropper<sup>1</sup>. Such a setup is often easier to realize since the jammer can for instance be set up in proximity to the legitimate receiver

and in certain settings, such as factory buildings, it may be feasible to assume that the attacker is located, e.g., outside of the building while the legitimate receiver and the transmitters are inside. With this scenario in mind, our proposed scheme exploits the assumption that the jammer’s signal is stronger at the legitimate receiver than it is at the eavesdropper. With that, it ensures that the eavesdropper observes a signal very similar to one jammed by white noise, while allowing the legitimate receiver to reconstruct the exact jamming sequence used and thus cancel it from its own received signal.

### A. Summary of the Main Contributions and Outline

The main contributions of this paper are as follows:

- 1) We propose a novel framework and result for incorporating security considerations by including a friendly jammer in the system which deteriorates the eavesdropper’s SNR while not impacting the legitimate receiver’s ability to obtain an approximation of the function value which is to be OTA computed.
- 2) We show how this jamming strategy can be applied in the example case in which the channel is AWGN and the OTA computed function is an arithmetic average, and we prove that the security guarantee translates to a lower bound on the mean square error of the eavesdropper’s function estimate.
- 3) We prove a theorem on compound channel coding for continuous alphabets. It is a generalization of the result of the part of [8] which considers finite Gaussian channels and we can consequently recover this result as a special case.

For 1, we use two information theoretic tools, namely *coding for the compound channel* and *channel resolvability*. The latter ensures that the jamming signal can be reconstructed fully by the legitimate receiver<sup>2</sup> and thus be canceled from the received signal. Therefore, it has no impact on the quality of the objective function estimate. Channel resolvability guarantees that the jamming signal is virtually indistinguishable from white noise for the eavesdropper. This virtual indistinguishability is phrased in terms of variational distance between the actually observed distribution and a superposition of the transmitters’ signal with white noise from the jammer. The coding result for the continuous compound channel which we derive may also be of interest as an independent result.

In Section I-B, we survey the related literature. In Section II, we describe the system model considered in this work. We illustrate the idea with an application to the AWGN case in Section III before we give an overview of our main results

Part of this work was presented in [1] at the 2021 IEEE International Symposium on Information Theory, 12-20 July 2021, Melbourne, Victoria, Australia.

This work was supported by the German Research Foundation (DFG) within their priority program SPP 1798 “Compressed Sensing in Information Processing” and under grant STA 864/7-1. This work was also supported by the German Federal Ministry of Education and Research under grant 16KIS0605.

<sup>1</sup>For a formal statement of this condition, see the statement of Theorem 1.

<sup>2</sup>For a formal statement, see Definition 2.

in Section IV. Section V details how our main result can be applied to classes of Gaussian channels, focusing in particular on the simple AWGN example from Section III. In Section VI, we collect the detailed proofs of our results, and Section VII concludes the paper and states open questions for future research.

### B. Prior Work

To the best of our knowledge, the OTA computation problem over a wiretap channel has not yet been considered in the literature. Therefore, in this subsection we briefly summarize the literature on the building blocks we use for the approach to the wiretap OTA computation channel that we propose in this work as well as for literature on concepts that are closely related to the ones presented in this paper.

a) *OTA computation*: The concept was originally introduced in [9]. In [3], [10], this idea was adapted to a setting where the domain and range of the function to be computed are continuous and the receiver can deal with a noisy estimate of the objective function value. In [4]–[6], we revisited this idea, adapted the existing scheme and provided an extension to a large class of functions and analysis of the estimation error for finite block length in a very general, fast-fading setting. There are many more prior works in this area. For details, we refer the reader to the literature section in [6].

b) *Coding for compound channels*: The compound channel problem was introduced independently in [11]–[13], while first independent results for the capacity expression can be found in [12], [13]. These works, however, explore mainly the case of finite input and output alphabets. The *semicontinuous* case in which only the input alphabet is assumed to be finite is briefly touched upon in [13] and studied in more detail in [14] which provides an example showing that the capacity expression from the finite case does not carry over to the semicontinuous case in general. The semicontinuous case was further explored in [15], [16]. In many cases of practical interest, the capacity expression from the finite case can be generalized to the *continuous* case in which neither input nor output alphabets are assumed to be finite, as was found in [8] for a class of Gaussian compound channels.

c) *Channel Resolvability and Semantic Security*: The concept of channel resolvability was introduced in [17], [18]. Further results relevant in the context of this work appeared, e.g., in [19]–[22]. We use our generalization [23] for continuous channels as a basis for our proposed scheme. Although we cannot provide full semantic security guarantees in this work, we also heavily draw from the idea of obtaining semantic security by means of channel resolvability, which is laid out in [24]–[27].

d) *Friendly Jamming*: The idea of friendly jamming has been used in [28] to aid a transmitter-receiver pair in protecting a point-to-point transmission from a passive eavesdropper. Distributed and centralized beamforming techniques are used so that the jamming signal impacts the signal-to-noise ratio at the eavesdropper but not at the legitimate receiver. Several more recent works (cf., e.g., [29]–[31]) have expanded upon this idea and refined the friendly jamming techniques, but to

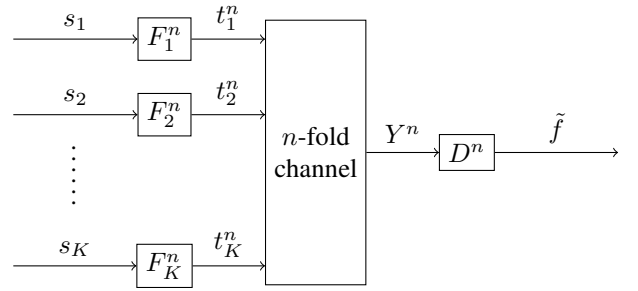

Fig. 1. System model for distributed function approximation described in Section II-A.

the best of our knowledge, they have not yet been used to protect Over-the-Air computation against eavesdropping.

e) *Physical Layer Security*: The concept of information theoretic secrecy was introduced in [32] and the wiretap channel model together with a weaker, but more tractable notion of secrecy was introduced in [33]. Based on this, various stronger secrecy notions have been introduced and investigated (e.g., [26], [34], [35]). All of these existing works investigate how digitally coded transmissions can be protected against eavesdropping, while in the present work, we focus on uncoded analog transmissions over multiple-access channels.

## II. SYSTEM MODEL

### A. Distributed Approximation of Functions

In this subsection, we summarize the system model of the framework for analog OTA computation from [4]. This particular framework is called *Distributed Function Approximation*.

Let  $\mathcal{S}_1, \dots, \mathcal{S}_K$  be measurable spaces. The goal is to approximate functions  $f : \mathcal{S}_1 \times \dots \times \mathcal{S}_K \rightarrow \mathbb{R}$  over a multiple-access channel  $W$  with measurable input alphabets  $\mathcal{X}_1, \dots, \mathcal{X}_K$  and a measurable output alphabet  $\mathcal{Y}$  in a distributed setting. An admissible distributed function approximation scheme for  $f : \mathcal{S}_1 \times \dots \times \mathcal{S}_K \rightarrow \mathbb{R}$  for  $n$  channel uses, depicted in Fig. 1, is a pair  $(F^n, D^n)$ , consisting of:

- 1) A pre-processing function  $F^n = (F_1^n, \dots, F_K^n)$  for the transmitters  $A_1, \dots, A_K$ , where each  $F_k^n$  is of the form

$$F_k^n(s_k) = (t_{k,j}(s_k, U_k(j)))_{j=1}^n \in \mathcal{X}_k^n$$

with i.i.d. random variables  $U_k(1), \dots, U_k(n)$  and a measurable map

$$(s_k, u_1, \dots, u_n) \mapsto (t_{k,j}(s_k, u_j))_{j=1}^n \in \mathcal{X}_k^n.$$

- 2) A post-processing function  $D^n$  for the receiver  $B$ : The receiver is allowed to apply a measurable recovery function  $D^n : \mathcal{Y}^n \rightarrow \mathbb{R}$  upon observing the output of the channel.

Note that this, contrary to the system model in [4], imposes the restriction that the pre-processing is i.i.d. across channel uses, which will be crucial for the security extension to the approximation scheme. Although this definition of admissible schemes is slightly less general, the scheme proposed in [4] still is an admissible scheme even in this stricter sense.

So in order to approximate  $f$ , the transmitters apply their pre-processing maps to

$$(s_1, \dots, s_K) \in \mathcal{S}_1 \times \dots \times \mathcal{S}_K$$

resulting in  $F_1^n(s_1), \dots, F_K^n(s_K)$ , which are sent over the channel. The receiver observes the output of the channel and applies the recovery map  $D^n$ . The whole process defines an estimate  $\tilde{f}$  of  $f$ .

Depending on the application at hand, there are multiple ways in which the quality of the estimate  $\tilde{f}$  can be quantified.

**Definition 1.** 1) Let  $\delta, \varepsilon \in (0, 1)$  and  $f$  be given. We say that  $f$  is  $\delta$ -approximated after  $n$  channel uses with confidence level  $\varepsilon$  if there is an approximation scheme  $(F^n, D^n)$  such that the resulting estimate  $\tilde{f}$  of  $f$  satisfies

$$\mathbb{P} \left( \left| \tilde{f} - f(s_1, \dots, s_K) \right| \geq \delta \right) \leq \varepsilon$$

for all  $s^K := (s_1, \dots, s_K) \in \mathcal{S}_1 \times \dots \times \mathcal{S}_K$ .

2) We say that  $f$  is  $V$ -MSE-approximated if, under a uniform distribution of  $f(s_1, \dots, s_K)$ , we have

$$\mathbb{E} \left( \left( \tilde{f} - f(s_1, \dots, s_K) \right)^2 \right) \leq V,$$

where the expectation is over the joint distribution of  $s_1, \dots, s_K$  and  $\tilde{f}$  which is induced by the distributed function approximation scheme and the channel.

Distributed Function Approximation schemes have to be tailored to the structure of  $W$ . It is worth noting, however, that for large classes of wireless channel models and objective functions, such schemes exist. In [4], we have proposed a Distributed Function Approximation scheme for fast-fading wireless channels with sub-Gaussian fading and noise, where the quality of approximation is defined as in item 1 of Definition 1. In [5], [6], we have extended the scheme to cases of correlated fading and noise. This means that the proposed scheme is applicable to fading wireless channels even in the presence of non-Gaussian and bursty interference and noise, and for various levels of mobility and richness of the scattering environment. However, a major limitation of these works is that the distributed data has to be transmitted without the possibility to encrypt or otherwise protect it against eavesdropping.

### B. Secrecy Extension to Distributed Approximation of Functions

In order to incorporate security aspects into the framework, we consider the extended system model depicted in Fig. 2.

The first addition to the model is an attacker  $E$  which attempts to eavesdrop on the transmission and wants to gain knowledge about  $s_1, \dots, s_K$ . At each channel use,  $E$  observes an output  $Z$  ranging over the eavesdropper's alphabet  $\mathcal{Z}$ . As a counter-measure, we add a friendly jammer  $J$  which transmits some jamming sequence  $X^n$  with the objective to prevent  $E$  from obtaining information while still allowing  $B$  to obtain a good estimate of  $f(s_1, \dots, s_K)$ .

**Definition 2.** A distributed function approximation scheme with jamming consists of:

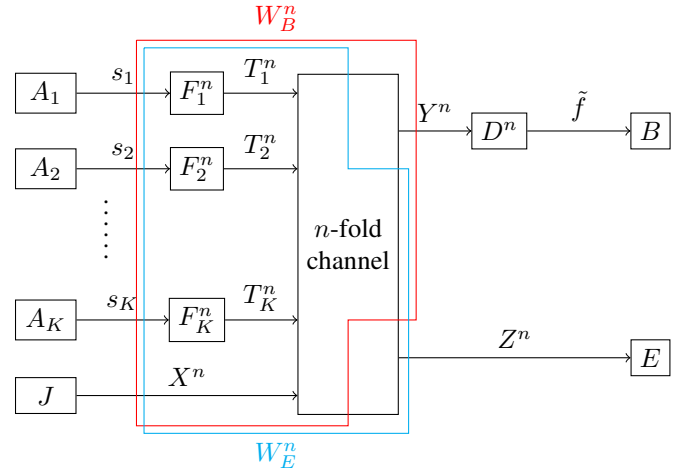

Fig. 2. System model for distributed function approximation with jamming described in Section II-B.

- A distributed function approximation scheme as described in Section II-A; i.e., pre- and post-processing schemes
- A jamming strategy given by a probability distribution on  $\mathcal{X}^n$ .

We say that a distributed function approximation scheme with jamming allows reconstruction of the jamming signal with probability  $\epsilon$  if there is a decoding function  $\vartheta : \mathcal{Y}^n \rightarrow \mathcal{X}^n$  such that

$$\sup_{s_1 \in \mathcal{S}_1, \dots, s_K \in \mathcal{S}_K} \mathbb{P}_{s_1, \dots, s_K} (\vartheta(Y^n) \neq X^n) \leq \epsilon$$

and  $\epsilon$  is the smallest number with this property.

The objective is to find admissible pre- and post-processing strategies as well as a jamming strategy such that  $B$  can obtain a good approximation  $\tilde{f}$  of  $f(s_1, \dots, s_K)$  while bounding the usefulness of any information that  $E$  can obtain about  $s_1, \dots, s_K$ .

Together with the channel, a distributed function approximation scheme with jamming induces a probability distribution  $\hat{R}_{s_1, \dots, s_K}$  on  $\mathcal{Z}^n$  for each  $(s_1, \dots, s_K) \in \mathcal{S}$ . How secure the scheme is depends on how strongly  $\hat{R}_{s_1, \dots, s_K}$  depends on  $s_1, \dots, s_K$ . In the following, we formalize this notion.

Any measurable function  $g : \mathcal{S} \rightarrow \mathcal{T}$ , where  $\mathcal{T}$  is a measurable space, is called an eavesdropper's objective.

**Definition 3.** 1) Given a real number  $\delta \geq 0$ , we say that a distributed function approximation scheme with jamming is  $\delta$ -semantically secure if there is a probability measure  $\mu$  on  $\mathcal{Z}^n$  such that for all  $(s_1, \dots, s_K) \in \mathcal{S}$ ,

$$\left\| \hat{R}_{s_1, \dots, s_K} - \mu \right\|_{\text{TV}} \leq \delta, \quad (1)$$

where  $\|\cdot\|_{\text{TV}}$  denotes the total variation norm on signed measures.

2) Let  $g : \mathcal{S} \rightarrow \mathcal{T}$ , where  $\mathcal{T} \subseteq \mathbb{R}$  is measurable and bounded, be an eavesdropper's objective. Let  $V \geq 0$  be a real number. We say that a distributed function approximation scheme with jamming is  $(g, V)$ -MSE-

secure if under a uniform distribution of  $g(s_1, \dots, s_K)$ , for every estimator  $d: \mathcal{Z}^n \rightarrow \mathcal{T}$ , we have

$$\mathbb{E} \left( (d(Z^n) - g(s_1, \dots, s_K))^2 \right) \geq V,$$

where the expectation is over the joint distribution of  $s_1, \dots, s_K$  and  $Z^n$  which results from the application of the distributed function approximation scheme with jamming and the channel.

In statistical terms, that a scheme is  $(g, V)$ -MSE-secure means that all estimators the eavesdropper can apply have mean square error (MSE) at least  $V$  under a uniformly distributed objective. A uniform distribution of the objective means that  $s_1, \dots, s_K$  are randomly distributed in such a way that  $g(s_1, \dots, s_K)$  follows a uniform distribution.

In a sense made explicit by the following lemma, semantic security is the stronger of the two security notions from Definition 3.

**Lemma 1.** *Let  $\mathcal{T} := [a, b]$ , let  $g: \mathcal{S} \rightarrow \mathcal{T}$  be an eavesdropper's objective and  $\delta \geq 0$  a real number.*

*Then, any distributed function approximation scheme with jamming that is  $\delta$ -semantically secure is also  $(g, (1/12 - \delta)(b - a)^2)$ -MSE-secure.*

*Proof.* Let  $d: \mathcal{Z}^n \rightarrow \mathcal{T}$ . Then, assuming the distribution of  $s_1, \dots, s_K$  corresponds to a uniform distribution on  $[a, b]$  of  $g(s_1, \dots, s_K)$ , we have

$$\begin{aligned} & \mathbb{E}_{s_1, \dots, s_K} \mathbb{E}_{\hat{R}_{s_1, \dots, s_K}} \left( (d(Z^n) - g(s_1, \dots, s_K))^2 \right) \\ &= \mathbb{E}_{s_1, \dots, s_K} \int_0^{(b-a)^2} \hat{R}_{s_1, \dots, s_K} \left( (d(Z^n) - g(s_1, \dots, s_K))^2 > t \right) dt \\ &\stackrel{(1)}{\geq} \mathbb{E}_{s_1, \dots, s_K} \int_0^{(b-a)^2} \left( \mu \left( (d(Z^n) - g(s_1, \dots, s_K))^2 > t \right) - \delta \right) dt \\ &= \mathbb{E}_{s_1, \dots, s_K} \mathbb{E}_\mu \left( (d(Z^n) - g(s_1, \dots, s_K))^2 \right) - \delta(b-a)^2 \\ &\geq \left( \frac{1}{12} - \delta \right) (b-a)^2, \end{aligned}$$

where the last step is because under  $\mu$ ,  $Z^n$  is independent of  $s_1, \dots, s_K$ . Therefore, the posterior distribution of  $g(s_1, \dots, s_K)$  given  $Z^n$  is uniform on  $[a, b]$ , which implies that the minimum MSE is the variance of the uniform distribution.  $\square$

### III. SPECIALIZATION TO THE AWGN CHANNEL

In general, the approximation scheme even without an eavesdropper or jammer highly depends on the particular structure of the channel and  $f$ . It is therefore instructive to consider a specialization of the Distributed Function Approximation framework with jamming to the computation

of arithmetic means over AWGN channels. Specifically, the objective function is given as

$$f: (s_1, \dots, s_K) \mapsto \frac{1}{K} \sum_{k=1}^K s_k, \quad (2)$$

where for all  $k$ ,  $\mathcal{S}_k = [-1, 1]$ . The channel is given by

$$Y = h_{AB} \sum_{k=1}^K T_k + h_{JB} X + N_B \quad (3)$$

$$Z = h_{AE} \sum_{k=1}^K T_k + h_{JE} X + N_E, \quad (4)$$

where each  $A_k$  is subject to a total power constraint of  $P_A$ ,  $J$  is subject to an average power constraint  $P_J$ ,  $N_B$  is centered normal with variance  $\sigma_B^2$  and  $N_E$  is centered normal with variance  $\sigma_E^2$ . The real channel coefficients  $h_{AB}, h_{JB}, h_{AE}, h_{JE}$  are assumed deterministic and known everywhere.

The problem is easily approached if we can assume that  $B$  has full knowledge of  $X^n$ , while  $E$  knows only how  $X^n$  is distributed.

In this case, we have the following result.

**Lemma 2.** *Consider the wiretap channel given by (3) and (4) and the objective function  $f$  defined in (2). Define*

$$\sigma_{\text{eff}, B}^2 := \frac{\sigma_B^2}{h_{AB}^2 K^2 P_A}, \quad \sigma_{\text{eff}, E}^2 := \frac{\sigma_E^2 + h_{JE}^2 P_J}{h_{AE}^2 K^2 P_A}$$

*Assume that the jamming sequence  $X^n$  is perfectly known at the legitimate receiver while the eavesdropper has only statistical information. Define*

$$\Psi(t) := \int_0^t \int_{-\infty}^{\infty} \left( v + \frac{\varphi_N(-v) - \varphi_N(t-v)}{\Phi_N(t-v) - \Phi_N(-v)} - u \right)^2 \cdot \frac{1}{t} \varphi_N(u-v) dv du, \quad (5)$$

where  $\varphi_N$  denotes the probability density function and  $\Phi_N$  the cumulative distribution function of the standard normal distribution, respectively. Then there is a distributed function approximation scheme with jamming which is  $(f, \sigma_{\text{eff}, E}^2 \Psi(2/\sigma_{\text{eff}, E}))$ -MSE-secure and  $(\sigma_{\text{eff}, B}^2 \Psi(2/\sigma_{\text{eff}, B}))$ -MSE-approximates  $f$  at the receiver.

The proof is based on a few facts from statistics. We only state the relevant lemmas here. For the sake of completeness, we include the proofs of the following two lemmas in Section VI-A.

**Lemma 3.** *If  $U$  is distributed uniformly in  $[a, b]$  and, conditioned on  $U$ ,  $V_1, \dots, V_n$  are i.i.d. normally distributed with mean  $U$  and variance  $\sigma^2$ , then the minimum MSE estimator for estimating  $U$  from the observations  $V_1, \dots, V_n$  is*

$$\hat{U} := \bar{V} + \frac{\sigma}{\sqrt{n}} \cdot \frac{\varphi_N \left( \frac{a - \bar{V}}{\sigma/\sqrt{n}} \right) - \varphi_N \left( \frac{b - \bar{V}}{\sigma/\sqrt{n}} \right)}{\Phi_N \left( \frac{b - \bar{V}}{\sigma/\sqrt{n}} \right) - \Phi_N \left( \frac{a - \bar{V}}{\sigma/\sqrt{n}} \right)}, \quad (6)$$

where  $\bar{V} := \frac{1}{n} \sum_{j=1}^n V_j$ .

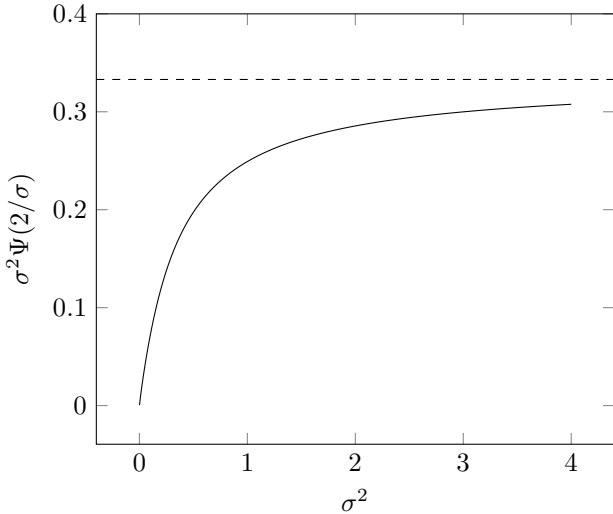

Fig. 3. Illustration of the MSE guarantees of Lemma 2. The dashed line is the MSE which an eavesdropper would have without any received signal (i.e., guessing the middle of the interval).

**Lemma 4.** *Under the assumptions of Lemma 3, the estimator  $\hat{U}$  satisfies*

$$\mathbb{E} \left( (U - \hat{U})^2 \right) = \frac{\sigma^2}{n} \Psi \left( \frac{b-a}{\sigma/\sqrt{n}} \right),$$

with  $\Psi$  as defined in (5).

*Proof of Lemma 2.* We use the following transmission strategy:

$$X_j : \text{Gaussian with mean 0 and variance } P_j, \quad (7)$$

$$F_k^n : s_k \mapsto (1, \dots, 1) \cdot s_k \sqrt{\frac{P_A}{n}} \quad (8)$$

The receiver can obtain

$$\begin{aligned} Y_j' &:= \frac{Y_j - h_{JB}X_j}{h_{AB}K\sqrt{P_A/n}} = \frac{h_{AB}\sum_{k=1}^K T_k + N_{B,j}}{h_{AB}K\sqrt{P_A/n}} \\ &= \frac{h_{AB}\sum_{k=1}^K s_k\sqrt{P_A/n} + N_{B,j}}{h_{AB}K\sqrt{P_A/n}} \\ &= f(s_1, \dots, s_K) + \frac{N_{B,j}}{h_{AB}K\sqrt{P_A/n}}. \end{aligned}$$

We define the post-processing operation  $D^n$  at the receiver as first obtaining  $Y_1', \dots, Y_n'$  and then computing the MSE estimator from Lemma 3. With this choice, Lemma 4 yields the claimed reconstruction error guarantee.

On the other hand, the output at  $E$  is given by

$$\begin{aligned} Z_j &\stackrel{(4)}{=} h_{AE} \sum_{k=1}^K T_k + h_{JE}X_j + N_{E,j} \\ &\stackrel{(8)}{=} h_{AE} \sum_{k=1}^K s_k\sqrt{P_A/n} + h_{JE}X_j + N_{E,j} \\ &\stackrel{(2)}{=} f(s_1, \dots, s_K) \cdot K\sqrt{P_A/n}h_{AE} + h_{JE}X_j + N_{E,j}. \end{aligned}$$

From this, Lemmas 3 and 4 yield the claimed MSE-security of the scheme.  $\square$

The assumption that the legitimate receiver has full knowledge of the jamming signal seems quite strong. So the main part of this paper is devoted to setting out and analyzing a jamming strategy in Theorem 1 which does not need any form of shared randomness or additional communication between the friendly jammer and the legitimate receiver. This jamming strategy has “almost” the same implications on the overall system performance as the assumption that the legitimate receiver has full knowledge of the jamming signal, while the eavesdropper only has knowledge about its distribution. In Corollary 2, we formalize this notion for the AWGN case. In principle, however, this jamming strategy is not restricted to the AWGN scenario; but in fact, it can be combined with any class of channel models in which it is possible to cancel or at least mitigate the effect of the jamming signal if exact knowledge of it is available.

One example where not a full cancellation but at least a good mitigation is possible is the fast-fading scenario introduced in [4].

## IV. MAIN RESULTS

In this section, we formally state the main results of this work.

A function approximation scheme is specific to a particular channel model, which among other things influences how the pre- and post-processing operations have to be designed as well as which class of functions can be approximated. In Section III, we have described such a scheme for the AWGN channel and only a singleton class of functions, namely for the arithmetic average, which is a particularly simple case. The strategy for the legitimate receiver to counter the signal of the friendly jammer given that it is known is also particularly simple in the AWGN case and can be done perfectly, as we have seen. The missing part of the secrecy extension, which is the method for the legitimate receiver to obtain the necessary knowledge of the jamming signal while the eavesdropper cannot, on the other hand, can be phrased and proven to work in somewhat greater generality. In order to formally state our main results, therefore, we have to introduce a few technical concepts first.

For any channel  $W$ , we denote the joint input-output distribution under  $P$  and  $W$  by  $Q_{P,W}$  and the marginal for  $\mathcal{Y}$  by  $R_{P,W}$ . With these conventions, we define the *information density* of tuples of elements of the input and output alphabets under the channel  $W$  and an input distribution  $P$  as

$$\mathbf{i}_{P,W}(x^n; y^n) := \log \frac{dW^n(x^n, \cdot)}{dR_{P,W}^n}(y^n).$$

Here and for the remainder of the paper, the functions  $\exp$  and  $\log$  both use Euler’s number as their basis, and all information quantities are consequently given in nats.

Correspondingly, the *mutual information* is defined as

$$\mathbf{I}_{P,W} := \mathbb{E}_{Q_{P,W}} \mathbf{i}_{P,W}(X; Y).$$

Moreover, given two probability measures  $\mu$  and  $\nu$ , we define the *Rényi divergence* of order  $\alpha \in (0, 1) \cup (1, \infty)$  between them as

$$D_\alpha(\mu||\nu) := \frac{1}{\alpha-1} \log \mathbb{E}_\mu \left( \left( \frac{d\mu}{d\nu} \right)^{\alpha-1} \right).$$

$D_1(\mu||\nu) := \lim_{\alpha \nearrow 1} D_\alpha(\mu||\nu)$  is the *Kullback-Leibler divergence*.

A *compound channel* is a family  $(W_s)_{s \in \mathcal{S}}$  of memoryless time-discrete point-to-point channels with common input alphabet  $\mathcal{X}$  and output alphabet  $\mathcal{Y}$ . The transmitter's channel input is passed through a fixed  $W_s$  for the entire block length, but the transmitter does not control the choice of  $s$ , nor is it governed by a probability distribution. In this work, we assume neither the transmitter nor the receiver knows  $s$ . A *compound channel code* with block length  $n$  and rate  $R$  consists of an encoder  $e : \{1, \dots, \exp(nR)\} \rightarrow \mathcal{X}^n$  and a decoder  $d : \mathcal{Y}^n \rightarrow \{1, \dots, \exp(nR)\}$ . We say that it has error probability  $\epsilon$  if uniformly for all  $m \in \{1, \dots, \exp(nR)\}$ , if  $Y^n$  is constructed by passing the components of  $X^n := e(m)$  independently through  $W_s$ , we have

$$\sup_{s \in \mathcal{S}} \mathbb{P}_s(m \neq d(Y^n)) \leq \epsilon,$$

where  $\epsilon$  is the smallest number with this property.

Our secrecy scheme will hinge on the capacity of compound channels with possibly continuous alphabets (such as Gaussian compound channels). As mentioned in Section I, it is shown in [14] that even in the case that only the output alphabet is countably infinite, the capacity expressions from the finite case [12], [13] do not carry over. It is therefore clear that an additional assumption on the compound channel is needed. In existing literature (e.g., [8], [12]), the problem is often approached by proving that the compound channel can be approximated by a finite class of channels in which case classical channel coding techniques such as joint typicality decoding can be adapted in a straightforward manner. In this work, we choose to directly pose the approximability of the compound channel by a finite class of channels as an assumption of our coding theorem. In Section V-A, we justify the usefulness of results involving this assumption by proving that a large class of practically relevant channels can indeed be approximated in the sense of the following definition.

Given measures  $\mu$  and  $\nu$ , we say that  $\mu$  is absolutely continuous with respect to  $\nu$ , or  $\mu \ll \nu$ , if all  $\nu$ -null sets are also  $\mu$ -null sets.

**Definition 4.** Given a compound channel  $(W_s)_{s \in \mathcal{S}}$  with input alphabet  $\mathcal{X}$  and output alphabet  $\mathcal{Y}$ , we say that it can be  $(\delta, J)$ -approximated under a probability distribution  $P$  on  $\mathcal{X}$  if there is a sequence  $(\hat{W}_{\delta,j})_{j=1}^J$  of channels from  $\mathcal{X}$  to  $\mathcal{Y}$  such that for every  $s \in \mathcal{S}$ , there is  $j \in \{1, \dots, J\}$  such that

$$\mathbb{E}_P D_1 \left( W_s(X, \cdot) || \hat{W}_{\delta,j}(X, \cdot) \right) \leq \delta \quad (9)$$

$$\exists \alpha > 1 \forall x \in \mathcal{X} : D_\alpha \left( W_s(x, \cdot) || \hat{W}_{\delta,j}(x, \cdot) \right) < \infty \quad (10)$$

$$\forall x \in \mathcal{X} : \hat{W}_{\delta,j}(x, \cdot) \ll W_s(x, \cdot) \quad (11)$$

$$\mathbf{I}_{P, \hat{W}_{\delta,j}} - \mathbf{I}_{P, W_s} \leq \delta, \quad (12)$$

and for every  $j \in \{1, \dots, J\}$  there is  $s \in \mathcal{S}$  such that

$$\mathbf{I}_{P, W_s} - \mathbf{I}_{P, \hat{W}_{\delta,j}} \leq \delta. \quad (13)$$

The discussion in Section V-A provides sufficient topological conditions for  $(\delta, J)$ -approximability and show that an example of channels with this property are (possibly fading) Gaussian channels.

We use a standard random codebook construction: Given a channel input alphabet  $\mathcal{X}$ , a distribution  $P$  on  $\mathcal{X}$ , a block length  $n$  and a rate  $R$ , we define the  $(P, n, R)$ -ensemble of codebooks as a random experiment in which  $\exp(nR)$  codewords of length  $n$  are drawn randomly and independently according to  $P$  for each component of each codeword.

A codebook  $\mathcal{C}$  induces a jamming strategy in the following way: The jammer draws a codeword index  $M$  uniformly at random and transmits  $\mathcal{C}(M)$ , the codeword in  $\mathcal{C}$  indexed by  $M$ . Therefore, the number of codewords in the codebook controls the amount of randomness contained in the jamming signal.

In order to be able to impose an average power constraint on the jammer, we define an *additive cost constraint*  $(c, C)$  for an input alphabet  $\mathcal{X}$  consisting of a function  $c : \mathcal{X} \rightarrow \mathbb{R}_0^+$  and a number  $C \in \mathbb{R}_0^+$ . Given any  $n$ , we say that  $x^n \in \mathcal{X}^n$  satisfies the cost constraint if  $\sum_{j=1}^n c(x_j) \leq nC$ .

The specialization of this definition to a usual average power constraint would be to pick the square function as  $c$  and the maximum admissible average power as  $C$ .

As long as there is at least one  $x^n \in \mathcal{X}^n$  which satisfies the cost constraint  $(c, C)$ , given any codebook  $\mathcal{C}$  of block length  $n$ , we can define an associated *cost-constrained codebook*  $\mathcal{C}_{c,C}$  which is generated from  $\mathcal{C}$  by replacing all codewords that do not satisfy the cost constraint with  $x^n$ . Obviously, all codewords in a cost-constrained codebook satisfy the cost constraint. We say that a cost constraint  $(c, C)$  is *compatible* with an input distribution  $P$  if for a random variable  $X$  distributed according to  $P$ ,  $c(X)$  has a finite moment generating function in an interval about 0 and  $C > \mathbb{E}_P c(X)$ .

We assume a given pre-processing scheme which is admissible as defined in Section II-A and consider effective channels incorporating both the pre-processing at the transmitters and the physical channel. We denote the legitimate user's effective channel, which is a stochastic kernel mapping from  $\mathcal{S}_1 \times \dots \times \mathcal{S}_K \times \mathcal{X}$  to  $\mathcal{Y}$ , by  $W_B$  and the eavesdropper's effective channel, which is a stochastic kernel mapping from  $\mathcal{S}_1 \times \dots \times \mathcal{S}_K \times \mathcal{X}$  to  $\mathcal{Z}$ , by  $W_E$ . The  $n$ -fold products of these effective channels are outlined in the system model in Fig. 2. With these concepts and notations defined, we are ready to state the main result of this work, which gives sufficient conditions for the existence of a jamming scheme that can simultaneously ensure that the legitimate receiver is able to reconstruct the full jamming signal and limit the usefulness of the eavesdropper's received signal.

**Theorem 1.** Let  $P$  be a jammer input distribution. Suppose that for every  $\delta > 0$ , there is some  $J(\delta)$  such that the compound channel  $(W_s)_{s \in \mathcal{S}}$  defined by  $W_{(s_1, \dots, s_K)} := W_B(s_1, \dots, s_K, \cdot, \cdot)$  can be  $(\delta, J(\delta))$ -approximated under  $P$ .

Suppose further that for all  $s_1 \in \mathcal{S}_1, \dots, s_K \in \mathcal{S}_K$ , the moment-generating function

$$\mathbb{E} \exp(t \cdot \mathbf{i}_{P, W_E(s_1, \dots, s_K, \cdot)}(X; Z))$$

of the information density exists and is finite at some point  $t > 0$ . Let  $(c, C)$  be an additive cost constraint compatible with  $P$ . Given a number  $R$  such that

$$\begin{aligned} \sup_{s_1 \in \mathcal{S}_1, \dots, s_K \in \mathcal{S}_K} \mathbf{I}_{P, W_E(s_1, \dots, s_K, \cdot)} &< R \\ &< \inf_{s_1 \in \mathcal{S}_1, \dots, s_K \in \mathcal{S}_K} \mathbf{I}_{P, W_B(s_1, \dots, s_K, \cdot)}, \end{aligned} \quad (14)$$

there are numbers  $\gamma_1, \gamma_2 > 0$  such that for sufficiently large  $n$ , there is a codebook  $\mathcal{C}$  in the  $(P, n, R)$ -ensemble such that the jamming strategy induced by  $\mathcal{C}_{c, C}$  allows reconstruction of the jamming signal with error at most  $\exp(-n\gamma_1)$ , while the eavesdropper's output  $\hat{R}_{W_E(s_1, \dots, s_K, \cdot)^n, \mathcal{C}_{c, C}}$  satisfies

$$\begin{aligned} \left\| \hat{R}_{W_E(s_1, \dots, s_K, \cdot)^n, \mathcal{C}_{c, C}} - R_{P, W_E(s_1, \dots, s_K, \cdot)}^n \right\|_{\text{TV}} \\ < \exp(-n\gamma_2). \end{aligned} \quad (15)$$

Obviously, the theorem is only useful if there exists some  $R$  satisfying (14). The condition that such an  $R$  exists is the formalization of the notion that the jamming signal has to be stronger at the legitimate receiver than it is at the eavesdropper.

In Section V-B, we discuss in more detail how the guarantee in (15) can be used to arrive at a MSE security guarantee for the scheme.

Theorem 1 needs a compound channel coding result as an ingredient for its proof, and since this result is slightly more general than results available in the literature, it may be of independent interest. Therefore, we also state it in this section.

**Theorem 2.** Let  $(W_s)_{s \in \mathcal{S}}$  be a compound channel with input alphabet  $\mathcal{X}$  and output alphabet  $\mathcal{Y}$ , and let  $P$  be a probability distribution on  $\mathcal{X}$  such that for every  $\delta > 0$ , there is a  $J(\delta)$  such that  $(W_s)_{s \in \mathcal{S}}$  can be  $(\delta, J(\delta))$ -approximated under  $P$ . Let

$$0 < R < \inf_{s \in \mathcal{S}} \mathbf{I}_{P, W_s}, \quad (16)$$

and let  $\mathcal{C}$  be a random codebook from the  $(P, n, R)$ -ensemble. Define an encoder  $m \mapsto \mathcal{C}(m)$ . Then there is a decoder such that the error probability  $\epsilon$  of the resulting compound channel code satisfies

$$\mathbb{E}_{\mathcal{C}}(\epsilon) < \exp(-n\gamma), \quad (17)$$

for some  $\gamma > 0$  and sufficiently large  $n$ .

With standard techniques, this theorem can be extended to the case of cost-constrained codebooks. We provide the full details of the proof of the following corollary in Section VI-D.

**Corollary 1.** In the setting of Theorem 2, and given an additive cost constraint  $(c, C)$  compatible with  $P$ , there are  $\gamma_1, \gamma_2 > 0$  such that for sufficiently large  $n$ ,

$$\mathbb{P}_{\mathcal{C}_{c, C}}(\mathbb{P}(\mathcal{E}) \geq \exp(-n\gamma_1)) < \exp(-n\gamma_2). \quad (18)$$

## V. IMPLICATIONS OF THE MAIN RESULTS

In this section, we show that the main result on secure OTA computation, Theorem 1, implies a MSE security guarantee in the case of AWGN channels discussed in Section III. To this end, we show in Section V-A that AWGN compound channels satisfy (among other channel models) the approximability criterion of Definition 4. In Section V-B, we show how Theorem 1 can be applied to carry the MSE security result of Lemma 2 over to the case in which the legitimate receiver does not share randomness with the jammer.

### A. Feasibility of Channel Approximation

In this subsection, we provide some tools and examples to argue that many compound channels of practical interest can indeed be  $(\delta, J)$ -approximated so that Theorem 2 may be applied to them. We begin with an observation that shows how our result specializes to the known results [12], [13] for channels with finite alphabets.

**Remark 1.** [12, Lemma 4] implies that for every compound channel  $(W_s)_{s \in \mathcal{S}}$  with finite input and output alphabets and every  $\delta > 0$ , there is an integer  $J(\delta)$  such that  $(W_s)_{s \in \mathcal{S}}$  can be  $(\delta, J(\delta))$ -approximated.

We repeat the construction here and discuss how this fact is proved.

Let  $M$  be an integer which satisfies

$$M \geq \max\left(\frac{4|\mathcal{Y}|^3}{\delta^2}, \frac{2|\mathcal{Y}|^2}{\delta}\right).$$

Given  $s \in \mathcal{S}$ , we construct a channel  $W'_s$ . To this end, given any  $x \in \mathcal{X}$ , we fix an enumeration  $(y_k)_{k=1}^{|\mathcal{Y}|}$  such that the finite sequence  $(W_s(x, \{y_n\}))_{k=1}^{|\mathcal{Y}|}$  is nondecreasing. For every  $k < |\mathcal{Y}|$ , we can then uniquely choose a value for  $W'_s(x, \{y_n\})$  such that it is an integer multiple of  $1/M$  and

$$W_s(x, \{y_n\}) \leq W'_s(x, \{y_n\}) < W_s(x, \{y_n\}) + \frac{1}{M}. \quad (19)$$

It is argued in [12] that this leaves a positive probability mass for  $W'_s(x, \{y_{|\mathcal{Y}|}\})$  and therefore, this construction fully defines a channel  $W'_s$ . We define the approximation sequence  $(\hat{W}_{\delta, j})_{j=1}^{J(\delta)}$  as an enumeration of the set  $\{W'_s : s \in \mathcal{S}\}$ . The cardinality of this set is upper bounded by  $(M+1)^{|\mathcal{X}||\mathcal{Y}|}$  since all singleton probabilities are integer multiples of  $1/M$ .

For finite alphabets, (10) is trivially satisfied since Rényi divergence is in this case always finite [36]. Regarding the absolute continuity criterion (11), we recall that  $W'_s(x, \{y_{|\mathcal{Y}|}\})$  always has a positive probability, and for  $k < |\mathcal{Y}|$ , the assumption  $W_s(x, \{y_n\}) = 0$  immediately implies  $W'_s(x, \{y_{|\mathcal{Y}|}\}) = 0$  by (19), since 0 is the only integer multiple of  $1/M$  which is strictly smaller than  $1/M$ . The proof in [12] exploits (19) to prove that the absolute difference between the information of  $W_s$  and  $W'_s$  under any input distribution is at most  $2|\mathcal{Y}|^{3/2}M^{-1/2}$  (statement (c) of the lemma) which by our choice of  $M$  immediately implies (12) and (13). Moreover, it is shown that (19) also implies that for all  $x \in \mathcal{X}, y \in \mathcal{Y}$ ,

$$\log \frac{W_s(x, \{y\})}{W'_s(x, \{y\})} \leq \frac{2|\mathcal{Y}|^2}{M}$$

(statement (b) of the lemma) which by our choice of  $M$  implies (9).

For many channels of interest,  $(\delta, J(\delta))$ -approximability can be shown directly by going through properties (9) – (13). However, it is often easier to make an argument involving topological properties of  $\mathcal{S}$ . The following lemma provides some machinery to this end.

**Lemma 5.** *Let  $(W_s)_{s \in \mathcal{S}}$  be a compound channel with input alphabet  $\mathcal{X}$  and output alphabet  $\mathcal{Y}$ , let  $P$  be a probability distribution on  $\mathcal{X}$  and assume that there is a topology on  $\mathcal{S}$  such that  $\mathcal{S}$  is compact and*

$$\forall s_0 \in \mathcal{S} : s \mapsto \mathbb{E}_P D_1(W_s(X, \cdot) \| W_{s_0}(X, \cdot)) \quad (20)$$

*is upper semi-continuous at  $s_0$*

$$\forall s_1, s_2 \in \mathcal{S} \exists \alpha > 1 \forall x \in \mathcal{X} : \quad (21)$$

$$D_\alpha(W_{s_1}(x, \cdot) \| W_{s_2}(x, \cdot)) < \infty$$

$$s \mapsto \mathbf{I}_{P, W_s} \text{ is lower semicontinuous.} \quad (22)$$

Then, for any  $\delta > 0$ , there is  $J(\delta)$  such that  $(W_s)_{s \in \mathcal{S}}$  can be  $(\delta, J(\delta))$ -approximated under  $P$ .

*Proof.* Fix some  $\delta > 0$ . For a given  $s \in \mathcal{S}$ , consider

$$\{s' : \mathbb{E}_P D_1(W_{s'}(X, \cdot) \| W_s(X, \cdot)) < \delta\}$$

$$\cap \{s' : \mathbf{I}_{P, W_s} - \mathbf{I}_{P, W_{s'}} < \delta.\}$$

Clearly, (20) and (22) ensure that this intersection is a neighborhood of  $s$ , so we can find an open neighborhood  $\mathcal{A}_s$  contained in it. Thus,  $(\mathcal{A}_s)_{s \in \mathcal{S}}$  is an open cover of  $\mathcal{S}$  and therefore, the compactness of  $\mathcal{S}$  yields a finite subcover  $\mathcal{A}_{s_1}, \dots, \mathcal{A}_{s_{j(\delta)}}$ . We set  $\hat{W}_{\delta, j} := W_{s_j}$  and given any  $s \in \mathcal{S}$ , we choose  $j$  such that  $s \in \mathcal{A}_{s_j}$  and argue that  $\hat{W}_{\delta, j}$  satisfies (9), (10) and (12). To this end, we note that (10) and (11) follow from (21), while (9) and (12) are ensured by the definition of  $\mathcal{A}_{s_j}$ . Finally, (13) is trivially satisfied, concluding the proof.  $\square$

We now make use of Lemma 5 to prove that a large class of Gaussian fading multiple-input and multiple-output channels can actually be  $(\delta, J(\delta))$ -approximated and thus Theorem 2 can be applied to them. The class of compound channels covered in the following theorem contains the class considered in [8, Sections 3 and 4] as a proper subset. We denote the set of symmetric, positive semidefinite  $n \times n$ -matrices with  $\text{Sym}_+^n$  and the set of symmetric, positive definite  $n \times n$ -matrices with  $\text{Sym}_{++}^n$ .

**Theorem 3.** *Let  $\mathcal{X} = \mathbb{R}^j$ ,  $\mathcal{Y} = \mathbb{R}^i$ , let  $\mathcal{S}$  be a compact subset of  $\mathbb{R}^{ij} \times \text{Sym}_+^{ij} \times \mathbb{R}^i \times \text{Sym}_{++}^i$  (under the topology induced by the Frobenius norm). For any  $s = (\mu_H, \Sigma_H, \mu_N, \Sigma_N) \in \mathcal{S}$ , let  $W_s$  be the channel given by*

$$Y = HX + N,$$

where the channel input  $X$  has range  $\mathbb{R}^j$ , the channel output  $Y$  has range  $\mathbb{R}^i$ , the entries of the  $i \times j$  fading matrix  $H$  follow the distribution  $\mathcal{N}(\mu_H, \Sigma_H)$  and the additive noise  $N$  is independent of  $H$  and follows the distribution  $\mathcal{N}(\mu_N, \Sigma_N)$ . Let  $P$  be a distribution on  $\mathcal{X}$  and assume that either  $P$  is a

multivariate Gaussian with positive definite covariance matrix or that the support of  $P$  is contained in some compact set. Then, given any  $\delta > 0$ , there is  $J(\delta)$  such that  $(W_s)_{s \in \mathcal{S}}$  can be  $(\delta, J(\delta))$ -approximated under  $P$ .

*Proof.* We show that the conditions of Lemma 5 are met. [37] provides closed-form expressions for Rényi and Kullback-Leibler divergences between multivariate normal distributions. The only fact that we are going to use and which is apparent from these expressions, however, is that the Rényi and Kullback-Leibler divergences between two multivariate normal distributions are finite and continuous in the mean vectors and covariance matrices of the distributions wherever the covariance matrices are positive definite or, equivalently, both distributions are absolutely continuous with respect to the Lebesgue measure.

$\Sigma_N \in \text{Sym}_{++}^i$  and therefore, given any  $x \in \mathcal{X}$ ,  $W_s(x, \cdot)$  is absolutely continuous with respect to the Lebesgue measure and thus has a positive definite covariance matrix and a density  $p_{W_s(x, \cdot)}$ , which implies (21).

Next, from the well-known closed-form expression of the multivariate normal density, we know that for any  $x$  and  $y$ ,  $p_{W_s(x, \cdot)}(y)$  is continuous in  $s$ . The boundedness of  $\mathcal{S}$  implies a uniform upper bound on  $p_{W_s(x, \cdot)}(y)$ , so we can use the theorem of dominated convergence to argue that the marginal density  $p_{R_P, W_s}(y) = \mathbb{E}_P p_{W_s(X, \cdot)}(y)$  depends continuously on  $s$  for any fixed  $y$ . We write

$$\mathbf{I}_{P, W_s} = \mathbb{E}_{P R_P, W_s} \left( \frac{p_{W_s(X, \cdot)}(Y)}{p_{R_P, W_s}(Y)} \log \frac{p_{W_s(X, \cdot)}(Y)}{p_{R_P, W_s}(Y)} \right).$$

Since the integrand is lower bounded by  $-1/e$ , (22) follows as an application of Fatou's lemma.

Finally, in order to argue (20), we distinguish between the two cases in the statement of the theorem.

First, suppose that there is a compact subset  $\hat{\mathcal{X}} \subseteq \mathcal{X}$  with  $P(\mathcal{X} \setminus \hat{\mathcal{X}}) = 0$ . For any fixed  $s_0$ , the map

$$(s, x) \mapsto D_1(W_s(x, \cdot) \| W_{s_0}(x, \cdot))$$

is continuous, therefore the image of  $\mathcal{S} \times \hat{\mathcal{X}}$  is compact and hence bounded. We can therefore invoke the theorem of dominated convergence and argue that (20) is satisfied.

Now, suppose that  $P$  is multivariate Gaussian with positive definite covariance matrix. We write

$$\begin{aligned} & \mathbb{E}_P D_1(W_s(X, \cdot) \| W_{s_0}(X, \cdot)) \\ &= \mathbb{E}_P \mathbb{E}_{W_s(X, \cdot)} \log \frac{p_P(X) p_{W_s(X, \cdot)}(Y)}{p_P(X) p_{W_{s_0}(X, \cdot)}(Y)} \\ &= \mathbb{E}_{Q_{P, W_s}} \log \frac{p_{Q_{P, W_s}}(X, Y)}{p_{Q_{P, W_{s_0}}}(X, Y)} \\ &= D_1(Q_{P, W_s} \| Q_{P, W_{s_0}}). \end{aligned}$$

From our arguments above, given any  $s$ , the distribution  $Q_{P, W_s}$  is multivariate Gaussian with positive definite covariance matrix, which implies that (20) is satisfied.  $\square$



### B. Back to the AWGN case: Calculating MSE Security Guarantees

Revisiting the AWGN example from Section III, Theorem 1 and Lemma 2 imply MSE security and reconstruction guarantees in case the legitimate receiver does not know the jamming sequence, as we show in the following corollary.

**Corollary 2.** *Make the same assumptions and definitions as in Lemma 2, but do not assume that the legitimate receiver has knowledge of the jamming sequence  $X_1, \dots, X_n$ . Assume in addition that the channel from  $J$  to  $B$  is stronger than the channel from  $J$  to  $E$ , i.e.,  $h_{JB}/\sigma_B > h_{JE}/\sigma_E$ . Then there is a distributed approximation scheme with jamming and there are constants  $\gamma_1, \gamma_2 > 0$  such that for sufficiently large  $n$ , the following hold:*

- $B$  can approximate the objective function  $f(s_1, \dots, s_K)$  with a MSE not exceeding

$$\sigma_{\text{eff},B}^2 \Psi \left( \frac{2}{\sigma_{\text{eff},B}^2} \right) + \exp(-n\gamma_1) \quad (23)$$

- The scheme is  $(f, V)$ -MSE-secure, where

$$V := \sigma_{\text{eff},E}^2 \Psi \left( \frac{2}{\sigma_{\text{eff},E}^2} \right) - \exp(-n\gamma_2). \quad (24)$$

*Proof.* For the pre-processing at the transmitters, we use the same scheme as in the proof of Lemma 2 and begin by verifying that the resulting effective channels  $W_B$  and  $W_E$  with the input distribution  $P$  chosen to be Gaussian with mean 0 and variance  $P_J$  satisfy the assumptions of Theorem 1. Since the defined compound channel is a class of Gaussian channels with different means taking values in the compact set  $[-1, 1]$ , the approximability of the channel is an immediate consequence of Theorem 3. The finiteness of the moment-generating function of the information density can be seen by straightforward applications of the definitions of information density and Rényi divergence:

$$\begin{aligned} & \mathbb{E} \exp(t \cdot \mathbf{i}_{P, W_E(s_1, \dots, s_K, \cdot)}(X; Z)) \\ &= \mathbb{E} \left( \left( \frac{dW_E(s_1, \dots, s_K, X, \cdot)}{dR_{P, W_E(s_1, \dots, s_K, \cdot)}}(Z) \right)^t \right) \\ &= \exp \left( t \cdot \frac{1}{t} \log \mathbb{E} \left( \left( \frac{dW_E(s_1, \dots, s_K, X, \cdot)}{dR_{P, W_E(s_1, \dots, s_K, \cdot)}}(Z) \right)^t \right) \right) \\ &= \exp(t D_{t+1}(Q_{P, W_E(s_1, \dots, s_K, \cdot)} || P R_{P, W_E(s_1, \dots, s_K, \cdot)})) \end{aligned}$$

The Rényi divergence appearing at the end is between two multivariate Gaussian distributions and can be seen to be finite from the expressions given in [37]. In order to verify (14), we first note that the information expressions appearing are the capacities of the effective channels  $W_B$  and  $W_E$ . Since  $s_1, \dots, s_K$  change the mean of the channel only, they do not influence the capacity. Therefore, the infimum and supremum are over singleton sets. Consequently, the condition  $h_{JB}/\sigma_B > h_{JE}/\sigma_E$  ensures that there is some  $R$  satisfying (14).

Fix  $\gamma_1', \gamma_2'$  as claimed to exist in Theorem 1, and also fix  $\gamma_1, \gamma_2$  with  $0 < \gamma_1 < \gamma_1'$  and  $0 < \gamma_2 < \gamma_2'$ . Let the jamming

strategy be as described in Theorem 1 and let  $d : \mathcal{Z}^n \rightarrow [-1, 1]$  be an estimator for  $E$ . We can now bound the MSE of  $d$ :

$$\begin{aligned} & \mathbb{E}_{\hat{R}_{W_E(s_1, \dots, s_K, \cdot)}^n} \left( (d(Z^n) - f(s_1, \dots, s_K))^2 \right) \\ &= \int_0^4 \hat{R}_{W_E(s_1, \dots, s_K, \cdot)}^n \left( (d(Z^n) - f(s_1, \dots, s_K))^2 > t \right) dt \\ &\stackrel{(15)}{\geq} \int_0^4 \left( R_{P, W_E(s_1, \dots, s_K, \cdot)}^n \left( (d(Z^n) - f(s_1, \dots, s_K))^2 > t \right) \right. \\ &\quad \left. - \exp(-n\gamma_2') \right) dt \\ &= \mathbb{E}_{R_{P, W_E(s_1, \dots, s_K, \cdot)}^n} \left( (d(Z^n) - f(s_1, \dots, s_K))^2 \right) \\ &\quad - 4 \exp(-n\gamma_2'). \end{aligned}$$

Taking the lower bound for the MSE under  $R_{P, W_E(s_1, \dots, s_K, \cdot)}^n$  from Lemma 2 and noting  $\gamma_2 < \gamma_2'$ , we arrive at the expression in (24) for sufficiently large  $n$ .

For the reconstruction strategy at  $B$ , we first let  $B$  reconstruct the jamming signal as is possible by Theorem 1 and then post-process the received signal as is possible with knowledge of the jamming signal by Lemma 2. Using the error bound in Lemma 2 and observing that the maximum instantaneous square error is 4 since we are constrained to an interval of length 2 and that  $\gamma_1 < \gamma_1'$ , for sufficiently large  $n$  we arrive at (23).  $\square$

## VI. PROOFS

In this section, we prove the Lemmas used in the proof of 2 and our main results on secure OTA computation and compound channel coding, Theorems 1 and 2, as well as the corollaries that allow for the incorporation of an average cost constraint.

### A. Statistical Preliminaries for the Proof of Lemma 2

In this subsection, we prove the two lemmas used for the proof of Lemma 2.

*Proof of Lemma 3.* It is known [38, eq. (6.92)] that the MSE is minimized by the mean of the posterior probability distribution. We can therefore calculate the minimum MSE estimator given the observations  $v_1, \dots, v_n$  as follows, where we use  $p$  with random variables in the index to denote (conditional)

densities.

$$\begin{aligned}
\hat{U} &= \int_a^b u p_{U|V_1, \dots, V_n}(u|v_1, \dots, v_n) du \\
&\stackrel{(a)}{=} \int_a^b u \frac{p_{V_1, \dots, V_n|U}(v_1, \dots, v_n|u) p_U(u)}{p_{V_1, \dots, V_n}(v_1, \dots, v_n)} du \\
&= \frac{\int_a^b u p_{V_1, \dots, V_n|U}(v_1, \dots, v_n|u) p_U(u) du}{\int_a^b p_{V_1, \dots, V_n|U}(v_1, \dots, v_n|u) p_U(u) du} \\
&\stackrel{(b)}{=} \frac{\int_a^b u \exp\left(-\frac{1}{2\sigma^2} \sum_{j=1}^n (v_j - u)^2\right) du}{\int_a^b \exp\left(-\frac{1}{2\sigma^2} \sum_{j=1}^n (v_j - u)^2\right) du} \\
&= \frac{\int_a^b u \exp\left(-\frac{1}{2\sigma^2/n} \left(\frac{1}{n} \sum_{j=1}^n v_j^2 - 2u\bar{v} + u^2\right)\right) du}{\int_a^b \exp\left(-\frac{1}{2\sigma^2/n} \left(\frac{1}{n} \sum_{j=1}^n v_j^2 - 2u\bar{v} + u^2\right)\right) du} \\
&\stackrel{(c)}{=} \frac{\int_a^b u \exp\left(-\frac{1}{2\sigma^2/n} (\bar{v} - u)^2\right) du}{\int_a^b \exp\left(-\frac{1}{2\sigma^2/n} (\bar{v} - u)^2\right) du}
\end{aligned}$$

For (a), we have applied Bayes' rule. (b) is by observing that  $p_U(u) = 1/(b-a)$  is independent of  $u$  in  $[a, b]$  and  $p_{V_1, \dots, V_n|U}$  is the normal density. (c) is by multiplying

$$\exp\left(-\frac{1}{2\sigma^2/n} \left(\bar{v}^2 - \frac{1}{n} \sum_{j=1}^n v_j^2\right)\right)$$

on both sides of the fraction to complete the binomials.

The term we have calculated for  $\hat{U}$  is the mean of a normal distribution centered at  $\bar{v}$  with variance  $\sigma^2/n$  truncated in  $[a, b]$ . This is a distribution with a known mean [39, eq. 13.134], and hence we arrive at (6).  $\square$

*Proof of Lemma 4.* Based on the representation (6), we calculate the MSE as follows. We use the substitution rule, substituting  $v' := \frac{\bar{v}-a}{\sigma/\sqrt{n}}$  in (a) and  $u' := \frac{u-a}{\sigma/\sqrt{n}}$  in (b).

$$\begin{aligned}
&\mathbb{E}\left(\left(U - \hat{U}\right)^2\right) \\
&= \int_a^b \int_{-\infty}^{\infty} \left( \bar{v} + \frac{\sigma}{\sqrt{n}} \cdot \frac{\varphi_N\left(\frac{a-\bar{v}}{\sigma/\sqrt{n}}\right) - \varphi_N\left(\frac{b-\bar{v}}{\sigma/\sqrt{n}}\right)}{\Phi_N\left(\frac{b-\bar{v}}{\sigma/\sqrt{n}}\right) - \Phi_N\left(\frac{a-\bar{v}}{\sigma/\sqrt{n}}\right)} - u \right)^2 \\
&\quad \cdot \frac{1}{b-a} \cdot \frac{1}{\sigma/\sqrt{n}} \varphi_N\left(\frac{u-\bar{v}}{\sigma/\sqrt{n}}\right) d\bar{v} du \\
&\stackrel{(a)}{=} \int_a^b \int_{-\infty}^{\infty} \left( \frac{\sigma}{\sqrt{n}} \left( v' + \frac{\varphi_N(-v') - \varphi_N\left(\frac{b-a}{\sigma/\sqrt{n}} - v'\right)}{\Phi_N\left(\frac{b-a}{\sigma/\sqrt{n}} - v'\right) - \Phi_N(-v')}\right) \right. \\
&\quad \left. + a - u \right)^2 \cdot \frac{1}{b-a} \cdot \varphi_N\left(\frac{u-a}{\sigma/\sqrt{n}} - v'\right) dv' du \\
&\stackrel{(b)}{=} \int_0^{\frac{b-a}{\sigma/\sqrt{n}}} \int_{-\infty}^{\infty} \left( v' + \frac{\varphi_N(-v') - \varphi_N\left(\frac{b-a}{\sigma/\sqrt{n}} - v'\right)}{\Phi_N\left(\frac{b-a}{\sigma/\sqrt{n}} - v'\right) - \Phi_N(-v')}\right)^2 \\
&\quad \cdot \left(\frac{\sigma}{\sqrt{n}}\right)^3 \cdot \frac{1}{b-a} \cdot \varphi_N(u' - v') dv' du' \\
&= \frac{\sigma^2}{n} \Psi\left(\frac{b-a}{\sigma/\sqrt{n}}\right),
\end{aligned}$$

concluding the proof of the lemma.  $\square$

## B. Proof of Theorem 1

In order to prove Theorem 1, we decompose the system depicted in Fig. 2 into smaller (and more easily analyzed) subsystems by considering only a subset of the depicted terminals at a time.

*a) Considering the terminals  $A_1, \dots, A_K, B$ :* This is the system summarized in Section II-A. The rationale is that the results specialize to the setting in Section III as well as, e.g., to the fast-fading setting introduced in [4]. This part of the system consists of transmitters  $(A_k)_{k=1}^K$  each of which holds a value  $s_k \in \mathcal{S}_k$  and a receiver  $B$  which has the objective of estimating  $f(s_1, \dots, s_K)$ . To this end, each transmitter  $A_k$  passes  $s_k$  through a pre-processor  $F_k$  independently  $n$  times yielding a sequence  $T_k^n$  of channel inputs. These are transmitted through  $n$  independent uses of the channel, generating a sequence  $Y^n$  of channel outputs. The receiver passes this sequence through a post-processor  $D^n$  which generates an approximation  $\tilde{f}$  of  $f(s_1, \dots, s_K)$ . As mentioned, the design of the pre- and post-processors depends heavily on the channel model and a particular class of functions  $f$ . The idea is that the pre-processors, the channel and the post-processor work together to mimic the function  $f$ , and any approach following this idea will be highly dependent on the particular structure of the channel and  $f$ . In Theorem 1, it is assumed that such a system is already in place and an augmentation is proposed which makes it more secure. A property of the system described in Section II-A necessary for our purposes and heavily exploited in this work is that the pre-processing is i.i.d., i.e., each pre-processor  $F_k$  is a stochastic kernel mapping from  $\mathcal{S}_k$  to  $\mathcal{T}_k$

and an  $n$ -fold product  $F_k^n$  of it is used to generate the channel input sequence.

b) *Considering the terminals  $A_1, \dots, A_K, J, E$ :* In this setting, we assume that the transmitters  $A_1, \dots, A_K$  run a scheme of the kind described under a). Instead of the legitimate receiver, there is now an eavesdropper  $E$ . The objective is then to limit the usefulness of the eavesdropper's received signal  $Z^n$ . To this end, we add a friendly jammer  $J$  to the system which transmits, according to a certain strategy, a word  $X^n$ . In this work, any jamming strategy we consider is induced by a codebook  $\mathcal{C}$  of words of length  $n$  through the rule that the jammer chooses an element of the codebook uniformly at random and transmits it. We use existing results on *channel resolvability* to derive a bound on the usefulness of the signal  $Z^n$  received at  $E$ .

c) *Considering the terminals  $A_1, \dots, A_K, J, B$ :* This is the setting from a) with an additional transmitter  $J$ . Here we assume that  $J$  uses a jamming strategy induced by a codebook  $\mathcal{C}$  as described under b) and use Theorem 2 on compound channel coding to argue that for suitable choices of  $\mathcal{C}$ ,  $B$  is able to fully reconstruct the jamming signal  $X^n$ . This enables  $B$  to perform a cancellation of the jamming signal before it applies the post-processor  $D^n$  it would use in setting a). How this cancellation works depends on the particularities of the channel considered, but if, e.g., the jamming signal is simply added to the channel output as in the AWGN example in Section III, it is possible to cancel it entirely by subtracting it from the received signal. So in this case the post-processor would consist of a reconstruction of the jamming signal, the subtraction of this signal from the received one and a post-processing step identical to that from a).

d) *Combining settings b) and c):* The goal here is to argue the existence of a codebook  $\mathcal{C}$  which achieves both of the objectives described under b) and c). It will turn out that this can be achieved by a standard random codebook construction.

The main result of this work, Theorem 1, formulates conditions under which there are codebooks in the  $(P, n, R)$ -ensemble of which the  $(c, C)$ -cost constrained versions simultaneously achieve the goals set forth under b) and c).

As a technical ingredient for our proof, we recall a result on channel resolvability from [23] that will be applied in order to guarantee the virtual indistinguishability of the jamming signal from white noise for the eavesdropper.

**Theorem 4.** [23] *Given a channel  $W$  from  $\mathcal{X}$  to  $\mathcal{Y}$ , an input distribution  $P$  such that the moment-generating function  $\mathbb{E}_{Q_{P,W}} \exp(t \cdot \mathbf{i}_{P,W}(X; Y))$  of the information density exists and is finite for some  $t > 0$ , and  $R > \mathbf{I}_{P,W}$ , there exist  $\gamma_1 > 0$  and  $\gamma_2 > 0$  such that for large enough block lengths  $n$ , the  $(P, n, R)$ -ensemble satisfies*

$$\mathbb{P}_{\mathcal{C}} \left( \|\hat{R}_{W,\mathcal{C}} - Q_{P,W}^n\|_{\text{TV}} > \exp(-\gamma_1 n) \right) \leq \exp(-\exp(\gamma_2 n)), \quad (25)$$

where  $\hat{R}_{W,\mathcal{C}}$  is the output distribution of channel  $W$  given that a uniformly random codeword from  $\mathcal{C}$  is transmitted.

Similarly as with the compound channel coding theorem, we can use known methods to incorporate an additive cost

constraint and argue the following corollary. For full details, we refer the reader to Section VI-D.

**Corollary 3.** *Let  $P$  be an input distribution on  $\mathcal{X}$  and  $(c, C)$  an additive cost constraint compatible with  $P$ . Then the statement of Theorem 4 is valid even if the codebook  $\mathcal{C}$  is replaced with its associated cost-constrained version  $\mathcal{C}_{c,C}$ .*

Given the previous observations, the proof of the main result of this work is now straightforward.

*Proof of Theorem 1.* We show that for cost-constrained random codebooks drawn from the  $(P, n, R)$ -ensemble, the probability that they do not satisfy the conclusion of the theorem tends to 0 exponentially. An application of Corollary 1 yields  $\gamma_1, \beta_1 > 0$  such that for sufficiently large  $n$ , the probability that the reconstruction error is at least  $\exp(n\gamma_1)$  is less than  $\exp(-n\beta_1)$ . We apply Corollary 3, which yields numbers  $\gamma_2, \beta_2 > 0$  such that the probability that (15) is not satisfied is at most  $\exp(-\exp(n\beta_2))$ . These two facts can be combined using the union bound so that the theorem follows.  $\square$

### C. Proof of Theorem 2

We first pick parameters  $\delta, \varepsilon, \beta_1$  and  $\beta_2$  in sequence according to the following scheme, where (16) and the previous choices ensure that these intervals are all nonempty.

$$\delta \in \left( 0, \frac{\inf_{s \in \mathcal{S}} \mathbf{I}_{P,W_s} - R}{3} \right) \quad (26)$$

$$\varepsilon \in \left( 2\delta, \inf_{s \in \mathcal{S}} \mathbf{I}_{P,W_s} - R - \delta \right) \quad (27)$$

$$\beta_1 \in (\delta, \varepsilon - \delta) \quad (28)$$

$$\beta_2 \in (0, \varepsilon - \delta - \beta_1) \quad (29)$$

Fix a sequence  $(\hat{W}_{\delta,j})_{j=1}^{J(\delta)}$  which  $(\delta, J(\delta))$ -approximates  $(W_s)_{s \in \mathcal{S}}$ .

We use a joint typicality decoder, i.e. if there is a unique  $m$  such that

$$\exists j \in \{1, \dots, J(\delta)\} : \mathbf{i}_{P,\hat{W}_{\delta,j}}(\mathcal{C}(m); Y^n) \geq n(\mathbf{I}_{P,\hat{W}_{\delta,j}} - \varepsilon),$$

the decoder declares that message  $m$  has been sent; otherwise it declares an error (or that message 1 has been sent).

We denote the transmitted message with  $M$ , the message declared by the decoder with  $\hat{M}$  and define error events

$$\mathcal{E} := \{M \neq \hat{M}\} \quad (30)$$

$$\mathcal{E}_1 := \left\{ \forall j \in \{1, \dots, J(\delta)\} \right. \quad (31)$$

$$\left. \mathbf{i}_{P,\hat{W}_{\delta,j}}(\mathcal{C}(M); Y^n) < n(\mathbf{I}_{P,\hat{W}_{\delta,j}} - \varepsilon) \right\}$$

$$\mathcal{E}_2 := \left\{ \exists m \neq M \exists j \in \{1, \dots, J(\delta)\} \right. \quad (32)$$

$$\left. \mathbf{i}_{P,\hat{W}_{\delta,j}}(\mathcal{C}(m); Y^n) \geq n(\mathbf{I}_{P,\hat{W}_{\delta,j}} - \varepsilon) \right\}.$$

We note that  $\mathcal{E} \subseteq \mathcal{E}_1 \cup \mathcal{E}_2$  and consequently

$$\mathbb{P}(\mathcal{E}) \leq \mathbb{P}(\mathcal{E}_1) + \mathbb{P}(\mathcal{E}_2). \quad (33)$$

So we can bound these two errors separately and then combine them.

We start with bounding the expectation of the first summand, using the definition (31) and  $\mathcal{C}$ , as well as an addition of zero. Pick  $j$  such that  $\hat{W}_{\delta,j}$  satisfies (9) – (12) with respect to the realization  $W_s$  of the compound channel. Then we have

$$\begin{aligned}
& \mathbb{E}_{\mathcal{C}}(\mathbb{P}(\mathcal{E}_1)) \\
& \leq \mathbb{E}_{\mathcal{C}} \left( \mathbb{P} \left( \mathbf{i}_{P, \hat{W}_{\delta,j}}(\mathcal{C}(M); Y^n) < n(\mathbf{I}_{P, \hat{W}_{\delta,j}} - \varepsilon) \right) \right) \\
& = Q_{P, W_s}^n \left( \mathbf{i}_{P, \hat{W}_{\delta,j}}(X^n; Y^n) < n(\mathbf{I}_{P, \hat{W}_{\delta,j}} - \varepsilon) \right) \\
& = Q_{P, W_s}^n \left( \sum_{j=1}^n \log \left( \frac{d\hat{W}_{\delta,j}(X_j, \cdot)}{dR_{P, \hat{W}_{\delta,j}}} (Y_j) \right) \right. \\
& \quad \left. < n(\mathbf{I}_{P, \hat{W}_{\delta,j}} + \mathbf{I}_{P, W_s} - \mathbf{I}_{P, W_s} - \varepsilon) \right) \tag{34}
\end{aligned}$$

The Radon-Nikodym derivative can be split as

$$\frac{d\hat{W}_{\delta,j}(X_j, \cdot)}{dR_{P, \hat{W}_{\delta,j}}} = \frac{d\hat{W}_{\delta,j}(X_j, \cdot)}{dW_s(X_j, \cdot)} \cdot \frac{dR_{P, W_s}}{dR_{P, \hat{W}_{\delta,j}}} \cdot \frac{dW_s(X_j, \cdot)}{dR_{P, W_s}}. \tag{35}$$

This is possible because  $\hat{W}_{\delta,j}(x, \cdot) \ll W_s(x, \cdot)$  by (11),  $R_{P, W_s} \ll R_{P, \hat{W}_{\delta,j}}$  by (9) and the joint convexity of Kullback-Leibler divergence in its arguments, and  $W_s(x, \cdot) \ll R_{P, W_s}$  for  $P$ -almost all  $x$  by the properties of the marginalization.

We next bound tail probabilities corresponding to the three factors in (35) separately, starting with the first. To this end, we introduce a number  $\alpha_1 > 0$  and argue, using Markov's inequality and the definition of Rényi divergence, that

$$\begin{aligned}
& Q_{P, W_s}^n \left( \sum_{j=1}^n \log \frac{dW_s(X_j, \cdot)}{d\hat{W}_{\delta,j}(X_j, \cdot)} (Y_j) \geq n\beta_1 \right) \\
& = Q_{P, W_s}^n \left( \exp \left( (\alpha_1 - 1) \sum_{j=1}^n \log \frac{dW_s(X_j, \cdot)}{d\hat{W}_{\delta,j}(X_j, \cdot)} (Y_j) \right) \right. \\
& \quad \left. \geq \exp((\alpha_1 - 1)n\beta_1) \right) \\
& \leq \mathbb{E}_{Q_{P, W_s}^n} \left( \left( \prod_{j=1}^n \left( \frac{dW_s(X_j, \cdot)}{d\hat{W}_{\delta,j}(X_j, \cdot)} (Y_j) \right)^{\alpha_1 - 1} \right) \right) \\
& \quad \cdot \exp(-(\alpha_1 - 1)n\beta_1) \\
& = \exp \left( \sum_{j=1}^n \log \left( \mathbb{E}_{Q_{P, W_s}^n} \left( \left( \frac{dW_s(X_j, \cdot)}{d\hat{W}_{\delta,j}(X_j, \cdot)} \right)^{\alpha_1 - 1} \right) \right) \right) \\
& \quad \cdot \exp(-(\alpha_1 - 1)n\beta_1) \\
& = \exp \left( -(\alpha_1 - 1)n \right. \\
& \quad \left. \cdot \left( \beta_1 - \mathbb{E}_P D_{\alpha_1} \left( W_s(X, \cdot) \parallel \hat{W}_{\delta,j}(X, \cdot) \right) \right) \right). \tag{36}
\end{aligned}$$

For the second factor, we argue in an analogous way, but using  $\alpha_2 > 0$ .

$$\begin{aligned}
& R_{P, W_s}^n \left( \sum_{j=1}^n \log \frac{dR_{P, \hat{W}_{\delta,j}}}{dR_{P, W_s}} (Y_j) \geq n\beta_2 \right) \\
& = R_{P, W_s}^n \left( \exp \left( \alpha_2 \sum_{j=1}^n \log \frac{dR_{P, \hat{W}_{\delta,j}}}{dR_{P, W_s}} (Y_j) \right) \right. \\
& \quad \left. \geq \exp(\alpha_2 n\beta_2) \right) \\
& \leq \mathbb{E}_{R_{P, W_s}^n} \left( \prod_{j=1}^n \left( \frac{dR_{P, \hat{W}_{\delta,j}}}{dR_{P, W_s}} (Y_j) \right)^{\alpha_2} \right) \exp(-\alpha_2 n\beta_2) \\
& = \exp \left( (\alpha_2 - 1)n D_{\alpha_2} \left( R_{P, \hat{W}_{\delta,j}} \parallel R_{P, W_s} \right) - \alpha_2 n\beta_2 \right). \tag{37}
\end{aligned}$$

Finally, for the third factor, we use  $\alpha_3 < 1$ .

$$\begin{aligned}
& Q_{P, W_s}^n \left( \mathbf{i}_{P, W_s}(X^n; Y^n) \right. \\
& \quad \left. < n(\mathbf{I}_{P, W_s} - \varepsilon + \beta_1 + \beta_2 + \delta) \right) \\
& = Q_{P, W_s}^n \left( \exp \left( (\alpha_3 - 1) \mathbf{i}_{P, W_s}(X^n; Y^n) \right) \right. \\
& \quad \left. > \exp \left( (\alpha_3 - 1)n(\mathbf{I}_{P, W_s} - \varepsilon + \beta_1 + \beta_2 + \delta) \right) \right) \\
& \leq \mathbb{E}_{Q_{P, W_s}^n} \left( \prod_{j=1}^n \left( \frac{dW_s(X_j, \cdot)}{dR_{P, W_s}} (Y_j) \right)^{\alpha_3 - 1} \right) \\
& \quad \cdot \exp \left( -(\alpha_3 - 1)n(\mathbf{I}_{P, W_s} - \varepsilon + \beta_1 + \beta_2 + \delta) \right) \\
& = \exp \left( -(1 - \alpha_3)n \left( D_{\alpha_3} \left( Q_{P, W_s} \parallel PR_{P, W_s} \right) \right. \right. \\
& \quad \left. \left. + \varepsilon - \mathbf{I}_{P, W_s} - \beta_1 - \beta_2 - \delta \right) \right), \tag{38}
\end{aligned}$$

Clearly, by (35), the union bound and (12), (34) is upper bounded by the sum of (36), (37) and (38). Next, we argue that these expressions all vanish exponentially with  $n \rightarrow \infty$ , using the continuity of Rényi divergence in the order which is shown in [36, Theorem 7].

From (10), the theorem of monotone convergence and (9), we can conclude that

$$\begin{aligned}
& \lim_{\alpha_1 \searrow 1} \mathbb{E}_P D_{\alpha_1} \left( W_s(X_j, \cdot) \parallel \hat{W}_{\delta,j}(X_j, \cdot) \right) \\
& = \mathbb{E}_P D_1 \left( W_s(X_j, \cdot) \parallel \hat{W}_{\delta,j}(X_j, \cdot) \right) \leq \delta,
\end{aligned}$$

so, (28) allows us to fix  $\alpha_1$  at a value greater than 1 such that  $\beta_1 - \mathbb{E}_P D_{\alpha_1} \left( W_s(X_j, \cdot) \parallel \hat{W}_{\delta,j}(X_j, \cdot) \right) > 0$  and hence, (36) vanishes exponentially.

(37) is true for all  $\alpha_2 < 1$ . Since the inequalities are not strict, we can take the limit  $\alpha_2 \nearrow 1$  and argue that the statement is also valid for  $\alpha_2 = 1$ .

$D_{\alpha_3} \left( Q_{P, W_s} \parallel PR_{P, W_s} \right)$  converges to  $\mathbf{I}_{P, W_s}$  from below for  $\alpha_3 \nearrow 1$  and so (29) allows us to fix  $\alpha_3$  at a value less than 1 such that  $D_{\alpha_3} \left( Q_{P, W_s} \parallel PR_{P, W_s} \right) + \varepsilon - \mathbf{I}_{P, W_s} - \beta_1 - \beta_2 - \delta > 0$  and therefore, (38) also vanishes exponentially.

For the second summand in (33), we use the definition (32) to argue that  $\mathbb{E}_{\mathcal{C}}(\mathbb{P}(\mathcal{E}_2))$  is upper bounded by

$$\begin{aligned} \exp(nR) \sum_{j=1}^{J(\delta)} P^n R_{P,W_s}^n \left( \mathbf{i}_{P,\hat{W}_{\delta,j}}(X^n; Y^n) \right. \\ \left. \geq n \left( \mathbf{I}_{P,\hat{W}_{\delta,j}} - \varepsilon \right) \right). \end{aligned} \quad (39)$$

We define the indicator function

$$\text{ind}(x^n, y^n) := \begin{cases} 1, & \mathbf{i}_{P,\hat{W}_{\delta,j}}(x^n; y^n) \geq n \left( \mathbf{I}_{P,\hat{W}_{\delta,j}} - \varepsilon \right) \\ 0, & \text{otherwise.} \end{cases}$$

Using the definition of information density for a change of measure and multiplying one, we rewrite the probability that appears in (39) as

$$\begin{aligned} & P^n R_{P,W_s}^n \left( \mathbf{i}_{P,\hat{W}_{\delta,j}}(X^n; Y^n) \geq n \left( \mathbf{I}_{P,\hat{W}_{\delta,j}} - \varepsilon \right) \right) \\ &= \int_{\mathcal{X}^n \times \mathcal{Y}^n} \text{ind}(x^n, y^n) \cdot P^n R_{P,W_s}^n(dx^n, dy^n) \\ &= \int_{\mathcal{X}^n \times \mathcal{Y}^n} \exp(-\mathbf{i}_{P,W_s}(x^n; y^n)) \text{ind}(x^n, y^n) Q_{P,W_s}^n(dx^n, dy^n) \\ &= \int_{\mathcal{X}^n \times \mathcal{Y}^n} \exp\left(-\mathbf{i}_{P,W_s}(x^n; y^n) + \mathbf{i}_{P,\hat{W}_{\delta,j}}(x^n; y^n) - \mathbf{i}_{P,\hat{W}_{\delta,j}}(x^n; y^n)\right) \\ & \quad \cdot \text{ind}(x^n, y^n) Q_{P,W_s}^n(dx^n, dy^n) \end{aligned}$$

Because of the presence of the indicator, we can uniformly bound

$$\mathbf{i}_{P,\hat{W}_{\delta,j}}(x^n; y^n) \geq n \left( \mathbf{I}_{P,\hat{W}_{\delta,j}} - \varepsilon \right)$$

and the indicator itself can be upper bounded by 1. This yields

$$\begin{aligned} & P^n R_{P,W_s}^n \left( \mathbf{i}_{P,\hat{W}_{\delta,j}}(X^n; Y^n) \geq n \left( \mathbf{I}_{P,\hat{W}_{\delta,j}} - \varepsilon \right) \right) \\ &\leq \exp\left(-n \left( \mathbf{I}_{P,\hat{W}_{\delta,j}} - \varepsilon \right)\right) \\ & \quad \int_{\mathcal{X}^n \times \mathcal{Y}^n} \exp\left(-\mathbf{i}_{P,W_s}(x^n; y^n) + \mathbf{i}_{P,\hat{W}_{\delta,j}}(x^n; y^n)\right) \\ & \quad \cdot Q_{P,W_s}^n(dx^n, dy^n) \end{aligned}$$

We expand the definition of information density and apply Fubini's Theorem to rewrite the integral as

$$\int_{\mathcal{Y}^n} \left( \int_{\mathcal{X}^n} \frac{d\hat{W}_{\delta,j}^n(x^n, \cdot)}{dR_{P,\hat{W}_{\delta,j}}^n}(y^n) P^n(dx^n) \right) R_{P,W_s}^n(dy^n)$$

and observe that it equals 1.

Combining with (39) and applying (13), we obtain

$$\begin{aligned} & \mathbb{E}_{\mathcal{C}}(\mathbb{P}(\mathcal{E}_2)) \\ &\leq \exp(nR) \sum_{j=1}^{J(\delta)} \exp\left(-n \left( \mathbf{I}_{P,\hat{W}_{\delta,j}} - \varepsilon \right)\right) \\ &\leq \exp(nR) \sum_{j=1}^{J(\delta)} \exp\left(-n \left( \inf_{s \in \mathcal{S}} \mathbf{I}_{P,W_s} - \varepsilon - \delta \right)\right) \\ &= \exp\left(-n \left( \inf_{s \in \mathcal{S}} \mathbf{I}_{P,W_s} - \varepsilon - R - \delta - \frac{\log J(\delta)}{n} \right)\right). \end{aligned} \quad (40)$$

We observe that by (27),  $\inf_{s \in \mathcal{S}} \mathbf{I}_{P,W_s} - \varepsilon - R - \delta > 0$ .

Finally, we pick

$$\begin{aligned} \gamma \in \left( 0, \min \left( \left( \alpha_1 - 1 \right) \right. \right. \\ \left. \left. \cdot \left( \beta_1 - \mathbb{E}_P D_{\alpha_1} \left( W_s(X_j, \cdot) \parallel \hat{W}_{\delta,j}(X_j, \cdot) \right) \right), \right. \right. \\ \left. \left. \beta_2, \right. \right. \\ \left. \left. \left( 1 - \alpha_3 \right) \left( D_{\alpha_3} \left( Q_{P,W_s} \parallel P_{R_{P,W_s}} \right) \right. \right. \right. \\ \left. \left. \left. + \varepsilon - \mathbf{I}_{P,W_s} - \beta_1 - \beta_2 - \delta \right), \right. \right. \\ \left. \left. \inf_{s \in \mathcal{S}} \mathbf{I}_{P,W_s} - \varepsilon - R - \delta \right) \right). \end{aligned}$$

Since the exponent in (40) is then negative for sufficiently large  $n$ , we can combine it with (36), (37) and (38) to obtain (17).  $\square$

#### D. Cost Constraint in Compound Channel Coding and Resolvability

In this section, we prove Corollaries 1 and 3 which essentially state that the conclusions of Theorems 2 and 4 are also true for the case of cost-constrained codebooks. The approach used is similar to the one in [40, Section 3.3], but we include the adapted derivations in full here for the sake of self-containedness. We begin with a series of preliminary lemmas and conclude the section with the proofs of the corollaries.

**Lemma 6.** *Let  $(U_k)_{k \geq 1}$  be a sequence of independent and identically distributed random variables such that the moment generating function  $\varphi(\lambda) := \mathbb{E} \exp(\lambda U_1)$  exists on an interval about 0. Let  $C > \mathbb{E} U_1$ . Then there exists  $\gamma > 0$  such that*

$$\mathbb{P} \left( \sum_{k=1}^n U_k > nC \right) \leq \exp(-n\gamma).$$

*Proof.* We can without loss of generality assume that  $C = 0$  and  $\mathbb{E}(U_1) < 0$ , because otherwise we could consider the random variables  $(U_k - C)_{k \geq 1}$  instead.

Clearly,  $\varphi(0) = 1$  and  $\varphi'(0) = \mathbb{E}(U_1) < 0$ , so we can find some  $\lambda > 0$  sufficiently small such that  $\varphi(\lambda) < 1$ . With this choice of  $\lambda$ , we can apply the Chernoff bound and get

$$\mathbb{P} \left( \sum_{k=1}^n U_k > 0 \right) \leq \mathbb{E} \left( \exp \left( \lambda \sum_{k=1}^n U_k \right) \right) = \varphi(\lambda)^n$$

so the lemma follows by choosing  $\gamma := -\log \varphi(\lambda)$ .  $\square$

**Lemma 7.** *Let  $N$  be a Bernoulli random variable with  $\exp(nR)$  trials and success probability  $p \leq \exp(-n\beta_1)$  where  $\beta_1 < R/2$ . Then there are  $\gamma_1, \gamma_2 > 0$  such that for sufficiently large  $n$ ,*

$$\mathbb{P}(N > \exp(n(R - \gamma_1))) \leq \exp(-\exp(n\gamma_2)). \quad (41)$$

*Proof.* We choose  $\gamma_1, \gamma_2$  and  $\beta_2$  such that  $0 < \gamma_1 < \beta_1 < \beta_2 < R/2$  and  $\gamma_2 < R - 2\beta_2$ . Then

$$\begin{aligned} & P_{\mathcal{C}}(N > \exp(n(R - \gamma_1))) \\ &= P_{\mathcal{C}}(N > p \exp(nR) + (\exp(-n\gamma_1) - p) \exp(nR)) \\ &\leq P_{\mathcal{C}}(N > \mathbb{E}_{P_{\mathcal{C}}} N + (\exp(-n\gamma_1) - \exp(-n\beta_1)) \exp(nR)) \\ &\leq P_{\mathcal{C}}(N > \mathbb{E}_{P_{\mathcal{C}}} N + \exp(-n\beta_2) \exp(nR)) \end{aligned} \quad (42)$$

$$\leq \exp(-2 \exp(n(R - 2\beta_2))) \quad (43)$$

$$\leq \exp(-\exp(n\gamma_2)), \quad (44)$$

where (43) follows by the Chernoff-Hoeffding bound.  $\square$

**Lemma 8.** *Let  $P$  be a probability distribution on  $\mathcal{X}$ . Assume moreover that  $c(X)$  has a moment generating function in an interval about 0 and that  $C > \mathbb{E}_{P_{\mathcal{C}}} c(X)$ . Denote the number of bad codewords in  $\mathcal{C}$  with*

$$N := \sum_{m=1}^{\exp(nR)} \mathbf{1}_{\sum_{j=1}^n c(\mathcal{C}(m)(j)) > nC}.$$

Then there are  $\gamma_1, \gamma_2 > 0$  such that

$$P_{\mathcal{C}}(N > \exp(n(R - \gamma_1))) \leq \exp(-\exp(n\gamma_2)). \quad (45)$$

*Proof.* Since the codeword components are independently and identically distributed, we can apply Lemma 6 and obtain an arbitrarily small  $\beta_1 > 0$  such that for all  $m$ ,

$$p := P_{\mathcal{C}} \left( \sum_{j=1}^n c(\mathcal{C}(m)(j)) > nC \right) \leq \exp(-n\beta_1).$$

So since the codewords are independent,  $N$  is a Bernoulli variable with  $\exp(nR)$  trials and success probability  $p$ , and an application of Lemma 7 proves the conclusion.  $\square$

*Proof of Corollary 1.* By Lemma 8, we pick  $\hat{\gamma}_1, \hat{\gamma}_2$  satisfying (45) and by Corollary 1, we pick  $\tilde{\gamma}_1, \tilde{\gamma}_2$  satisfying (18). We define  $\hat{\mathcal{E}} := \{\mathcal{C}(M) \neq \mathcal{C}_{e,C}(M)\}$  and note that

$$\mathbb{P}_{\mathcal{C}}(\mathbb{P}(\hat{\mathcal{E}}) \geq \exp(-n\hat{\gamma}_1)) < \exp(-\exp(n\hat{\gamma}_2)).$$

With the choices  $\gamma_1 < \tilde{\gamma}_1, \hat{\gamma}_1$  and  $\gamma_2 < \tilde{\gamma}_2$ , we get, for sufficiently large  $n$ ,

$$\begin{aligned} & \mathbb{P}_{\mathcal{C}_{e,C}}(\mathbb{P}(\mathcal{E}) \geq \exp(-n\gamma_1)) \\ &\leq \mathbb{P}_{\mathcal{C}}(\mathbb{P}(\mathcal{E}) + \mathbb{P}(\hat{\mathcal{E}}) \geq \exp(-n\gamma_1)) \\ &\leq \mathbb{P}_{\mathcal{C}}(\mathbb{P}(\mathcal{E}) \geq \exp(-n\tilde{\gamma}_1)) + \mathbb{P}_{\mathcal{C}}(\mathbb{P}(\hat{\mathcal{E}}) \geq \exp(-n\hat{\gamma}_1)) \\ &< \exp(-n\tilde{\gamma}_2) + \exp(-\exp(n\hat{\gamma}_2)) \\ &< \exp(-n\gamma_2). \end{aligned} \quad \square$$

*Proof of Corollary 3.* By Lemma 8, we pick  $\hat{\gamma}_1, \hat{\gamma}_2$  satisfying (45) and by Theorem 4, we pick  $\tilde{\gamma}_1, \tilde{\gamma}_2$  satisfying (25).

We use the observation that  $N \leq \exp((R - \hat{\gamma}_1)n)$  implies

$$\|R_{\mathcal{C}_{e,C}} - R_{\mathcal{C}}\|_{\text{TV}} \leq \frac{N}{\exp(nR)} \leq \exp(-\hat{\gamma}_1 n)$$

and the union bound to conclude that, as long as  $\gamma_1 < \hat{\gamma}_1, \tilde{\gamma}_1$  and  $\gamma_2 < \hat{\gamma}_2, \tilde{\gamma}_2$  and  $n$  is sufficiently large,

$$\begin{aligned} & \mathbb{P}_{\mathcal{C}_{e,C}}(\|R_{\mathcal{C}_{e,C}} - Q_{P,W}^n\|_{\text{TV}} > \exp(-\gamma_1 n)) \\ &\leq \mathbb{P}_{\mathcal{C}}(\|R_{\mathcal{C}_{e,C}} - R_{\mathcal{C}}\|_{\text{TV}} + \|R_{\mathcal{C}} - Q_{P,W}^n\|_{\text{TV}} > \exp(-\gamma_1 n)) \\ &\leq \mathbb{P}_{\mathcal{C}}(\|R_{\mathcal{C}_{e,C}} - R_{\mathcal{C}}\|_{\text{TV}} > \exp(-\hat{\gamma}_1 n)) \\ &\quad + \mathbb{P}_{\mathcal{C}}(\|R_{\mathcal{C}} - Q_{P,W}^n\|_{\text{TV}} > \exp(-\tilde{\gamma}_1 n)) \\ &< \exp(-\exp(\hat{\gamma}_2 n)) + \exp(-\exp(\tilde{\gamma}_2 n)) \\ &\leq \exp(-\exp(\gamma_2 n)). \end{aligned} \quad \square$$

## VII. CONCLUSION

In this work, we have introduced a framework for distributed function approximation schemes with jamming, we have shown how well-known information theoretic tools can be used to improve security by means of a jammer whose signal is stronger at the legitimate receiver than it is at the eavesdropper. In the process, we have proved a compound channel coding result which is a generalization of similar results from the literature. For the special case of an AWGN channel, we have proven MSE guarantees both for the eavesdropper's and the legitimate receiver's reconstruction of the objective function. For the case of fast-fading sub-Gaussian channels, we have presented a distributed function approximation scheme with theoretical guarantees for the tail probabilities of the absolute reconstruction error.

This work is intended as an initial step towards providing security against eavesdropping for OTA computation schemes. We have given theoretical analysis which shows that a large class of such schemes can be made more secure, but a gap between this theoretical work and its implementation for the envisioned practical applications remains. In particular, we are interested in the following questions for future research:

- Can the secrecy guarantees in this work be achieved with structured codes which allow for practically feasible encoding and decoding?
- Can the secrecy guarantees be strengthened to full semantic security?

## REFERENCES

- [1] M. Frey, I. Bjelakovic, and S. Stanczak, "Towards secure over-the-air computation," in *2021 IEEE International Symposium on Information Theory (ISIT)*. IEEE, 2021.
- [2] M. M. Amiri and D. Gündüz, "Machine learning at the wireless edge: Distributed stochastic gradient descent over-the-air," *IEEE Transactions on Signal Processing*, vol. 68, pp. 2155–2169, 2020.
- [3] K. Ralinovski, M. Goldenbaum, and S. Stańczak, "Energy-efficient classification for anomaly detection: The wireless channel as a helper," in *2016 IEEE International Conference on Communications (ICC)*, 2016, pp. 1–6.
- [4] I. Bjelaković, M. Frey, and S. Stańczak, "Distributed approximation of functions over fast fading channels with applications to distributed learning and the max-consensus problem," in *57th Annual Allerton Conference*. IEEE, 2019.
- [5] M. Frey, I. Bjelaković, and S. Stańczak, "Over-the-air computation in correlated channels," in *2020 IEEE Information Theory Workshop (ITW)*. IEEE, 2021, pp. 1–5.
- [6] M. Frey, I. Bjelakovic, and S. Stanczak, "Over-the-air computation in correlated channels," *arXiv:2007.02648*, 2020, accepted at *IEEE Transactions on Signal Processing*.
- [7] W. Liu, X. Zang, Y. Li, and B. Vucetic, "Over-the-air computation systems: Optimization, analysis and scaling laws," *IEEE Transactions on Wireless Communications*, vol. 19, pp. 5488–5502, 2020.

- [8] W. L. Root and P. P. Varaiya, "Capacity of classes of gaussian channels," *SIAM J. Appl. Math.*, vol. 16, no. 6, pp. 1350–1393, 1968.
- [9] B. Nazer and M. Gastpar, "Computation over multiple-access channels," *IEEE Trans. Inf. Theory*, vol. 53, no. 10, pp. 3498–3516, 2007.
- [10] M. Goldenbaum and S. Stanczak, "Robust analog function computation via wireless multiple-access channels," *IEEE Trans. Commun.*, vol. 61, no. 9, pp. 3863–3877, 2013.
- [11] R. L. Dobrushin, "Optimum information transmission through a channel with unknown parameters," *Radio Eng. Electron.*, vol. 4, no. 12, pp. 1–8, 1959.
- [12] D. Blackwell, L. Breiman, and A. J. Thomasian, "The capacity of a class of channels," *Ann. Math. Stat.*, vol. 30, no. 4, pp. 1229–1241, 1959.
- [13] J. Wolfowitz, "Simultaneous channels," *Arch. Ration. Mech. Anal.*, vol. 4, no. 1, pp. 371–386, 1959.
- [14] H. Kesten, "Some remarks on the capacity of compound channels in the semicontinuous case," *Inf. Control*, vol. 4, no. 2-3, pp. 169–184, 1961.
- [15] K. Yoshihara, "Coding theorems for the compound semi-continuous memoryless channels," in *Kodai Mathematical Seminar Reports*, vol. 17, no. 1. Department of Mathematics, Tokyo Institute of Technology, 1965, pp. 30–43.
- [16] R. Ahlswede, "Certain results in coding theory for compound channels," in *Proceedings of the Colloquium on Information Theory*, 1967.
- [17] A. Wyner, "The common information of two dependent random variables," *Trans. Inf. Theory*, vol. 21, no. 2, pp. 163–179, 1975.
- [18] T. S. Han and S. Verdú, "Approximation theory of output statistics," *Trans. Inf. Theory*, vol. 39, no. 3, pp. 752–772, 1993.
- [19] I. Csiszár, "Almost independence and secrecy capacity," *Problems Inform. Transmission*, vol. 32, no. 1, pp. 40–47, 1996.
- [20] I. Devetak, "The private classical capacity and quantum capacity of a quantum channel," *Trans. Inf. Theory*, vol. 51, no. 1, pp. 44–55, 2005.
- [21] M. Hayashi and R. Matsumoto, "Secure multiplex coding with dependent and non-uniform multiple messages," *IEEE Transactions on Information Theory*, vol. 62, no. 5, pp. 2355–2409, 2016.
- [22] P. Cuff, "Soft covering with high probability," in *2016 IEEE International Symposium on Information Theory (ISIT)*. IEEE, 2016, pp. 2963–2967.
- [23] M. Frey, I. Bjelakovic, and S. Stanczak, "Resolvability on continuous alphabets," in *2018 IEEE International Symposium on Information Theory (ISIT)*. IEEE, 2018, pp. 2037–2041.
- [24] M. Hayashi, "General nonasymptotic and asymptotic formulas in channel resolvability and identification capacity and their application to the wiretap channel," *IEEE Transactions on Information Theory*, vol. 52, no. 4, pp. 1562–1575, 2006.
- [25] I. Csiszar and J. Körner, *Information theory: coding theorems for discrete memoryless systems*. Cambridge: Cambridge University Press, 2011.
- [26] M. Bellare, S. Tessaro, and A. Vardy, "Semantic security for the wiretap channel," in *Advances in Cryptology—CRYPTO 2012*. Springer, 2012, pp. 294–311.
- [27] M. R. Bloch and J. N. Laneman, "Strong secrecy from channel resolvability," *Trans. Inf. Theory*, vol. 59, no. 12, pp. 8077–8098, 2013.
- [28] R. Negi and S. Goel, "Secret communication using artificial noise," in *IEEE vehicular technology conference*, vol. 62, no. 3. IEEE, 2005, p. 1906.
- [29] J. P. Vilela, M. Bloch, J. Barros, and S. W. McLaughlin, "Friendly jamming for wireless secrecy," in *2010 IEEE International Conference on Communications*. IEEE, 2010, pp. 1–6.
- [30] —, "Wireless secrecy regions with friendly jamming," *IEEE Transactions on Information Forensics and Security*, vol. 6, no. 2, pp. 256–266, 2011.
- [31] I. Stanojev and A. Yener, "Improving secrecy rate via spectrum leasing for friendly jamming," *IEEE Transactions on Wireless Communications*, vol. 12, no. 1, pp. 134–145, 2012.
- [32] C. E. Shannon, "Communication theory of secrecy systems," *Bell Labs Technical Journal*, vol. 28, no. 4, pp. 656–715, 1949.
- [33] A. D. Wyner, "The wire-tap channel," *Bell Labs Technical Journal*, vol. 54, no. 8, pp. 1355–1387, 1975.
- [34] U. M. Maurer, "The strong secret key rate of discrete random triples," in *Communications and Cryptography: Two Sides of One Tapestry*, R. E. Blahut, D. J. Costello, U. Maurer, and T. Mittelholzer, Eds. Boston, MA: Springer US, 1994, pp. 271–285.
- [35] J. Hou and G. Kramer, "Effective secrecy: Reliability, confusion and stealth," in *2014 IEEE International Symposium on Information Theory*. IEEE, 2014, pp. 601–605.
- [36] T. van Erven and P. Harremoës, "Rényi divergence and Kullback-Leibler divergence," *IEEE Trans. Inf. Theory*, vol. 60, no. 7, pp. 3797–3820, 2014.
- [37] M. Gil, "On Rényi divergence measures for continuous alphabet sources," Master's thesis, Queen's University Kingston, Ontario, Canada, 2011.
- [38] E. Jaynes, *Probability Theory: The Logic of Science*. Cambridge: Cambridge University Press, 2003.
- [39] N. L. Johnson, S. Kotz, and N. Balakrishnan, *Continuous Univariate Distributions*, 2nd ed., ser. Wiley Series in Probability and Mathematical Statistics. New York, Chichester, Brisbane, Toronto, Singapore: Wiley, 1994, vol. 1.
- [40] A. El Gamal and Y.-H. Kim, *Network information theory*. Cambridge: Cambridge university press, 2011.