

# Federated Learning for Localization: A Privacy-Preserving Crowdsourcing Method

Bekir Sait Ciftler, Abdullatif Albaseer, Nouredine Lasla, and Mohamed Abdallah  
Division of Information and Computing Technology, College of Science and Engineering,  
Hamad Bin Khalifa University, Doha, Qatar  
{bciftler, amalbaseer, nlasla, moabdallah}@hbku.edu.qa

**Abstract**—Received Signal Strength (RSS) fingerprint-based localization attracted a lot of research effort as well as cultivating many commercial applications of location-based services due to its low cost and ease of implementation. There are many studies exploring use of machine learning algorithms for RSS fingerprint-based localization. However, there are several problems due to the brittle nature of RSS which is susceptible to noise, dynamic environments, and hardware variations. These problems require frequent retraining of machine learning models with new data gathered by crowdsourcing. Although crowdsourcing is a good way to collect data, it has a privacy problem due to collection of raw data from participants. Federated learning enables to preserving privacy of the crowdsourcing participants by performing model training at the edge devices in a decentralized manner, data of participants is not exposed to centralized entity. This paper presents a novel method to improve the reliability and the robustness of RSS fingerprint-based localization while preserving privacy of the participants and the users by employing federated learning. Proposed method could achieve below 1 meters difference using federated learning compared to centralized learning for RSS fingerprint-based localization, and improved localization accuracy by 16% when used as a booster for centralized learning.

**Index Terms**—Crowdsourcing, Deep Learning, Federated Learning, Indoor Localization, Neural Networks, Privacy Preserving, Received Signal Strength.

## I. INTRODUCTION

Advances in the computational power and parallel processing abilities as well as availability of massive amount of data created a huge interest in the machine learning in many fields of wireless communications research including localization studies [1]. The proliferation of smart wearables enabled a wide range of location based services which relies on indoor localization systems. The a vast amount of sensory and communication data created by edge devices allowed machine learning-based localization methods which has been studied extensively recently [2].

There are sophisticated methods such as utilizing channel state information (CSI) [3], and there are simple methods only using received signal strength (RSS) [4], usually as a logarithmic function of distance to the transmitter. The machine learning-based localization systems have the problem of reliability and robustness due the dynamic environment and change in the wireless channel parameters which affects both CSI and RSS. Another problem with machine learning-based localization systems arises about heterogeneity of devices and the data acquisition. It requires to gather additional data to avoid underfitting of various fluctuations in the signal [5].

Crowdsourcing is a solution to handle the problem of gathering additional data from different devices at various

locations [6]. However there are privacy problems with traditional crowdsourcing techniques regarding the privacy of users. Traditional crowdsourcing technique relies on the users which send their data directly to the centralized unit. Although there are methods for handling privacy related problems such as data anonymization and encrypted evaluation, they are relatively harder to implement in real world applications due to complexity or cause a high degradation in the performance of applications.

Federated Learning is a comparatively recent method that is based on sharing local models with centralized unit without sending data [7]. It has gathered a tremendous interest recently due to privacy-preserving nature as well as efficient use of resources utilizing processing power at edge devices [8]. Federated learning enables a privacy-preserving edge learning method by performing the model training at the device keeping the data where it is gathered. It is also power and communication-wise efficient since it avoids transmission of huge amounts of data [9].

In this paper, we propose a novel privacy-preserving localization crowdsourcing system based on Federated Learning. Our main contributions includes mainly three advantages over other machine learning-based localization techniques.

- The main contribution of this work is enabling *a privacy-preserving crowdsourcing technique for localization* with keeping local data where it is generated and only conveying local model.
- In this study, federated learning is applied with various heterogeneity models according to real-world scenarios to show effect of heterogeneous data on localization accuracy and converge of the learning algorithm.
- Additionally applying multiple rounds with different numbers of users allowed to update the model iteratively, which makes it robust against heterogeneous environments.

This paper is structured as follows. In Section II, a brief overview of existing literature on traditional and machine learning-based fingerprint localization techniques is presented. Our proposed federated learning-based fingerprinting localization technique is explained in Section III. Subsequently, results for three comprehensive scenarios are presented in Section IV. Finally, in Section V, we present our concluding remarks.

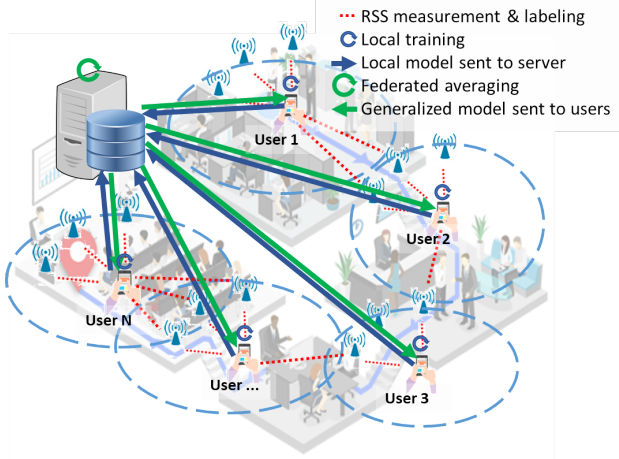

Fig. 1: Federated learning-based crowdsourcing system.

## II. LITERATURE REVIEW

Fingerprinting-based localization is highly popular due to ease of implementation and high accuracy. There are a number of traditional fingerprinting applications such as [10], where the system employs a probabilistic approach utilizing the RSS histogram of the access points for location clustering. Another well-known technique is a statistical approach based on k-Nearest-Neighbors (kNN).

Localization research utilizing machine learning has gained momentum with the availability of vast amounts of data incorporating location-related information gathered from smart devices as well as increase in the computational power. The authors propose a method based on deep learning using CSI as input in [3], and they compared their method and shown excellence to traditional methods such as HORUS [10] and maximum likelihood [11]. The authors subsequently published several other studies utilizing calibrated phase information of CSI [12], a Convolutional Neural Network model based on angle of arrival information [13], and a bi-modal framework to improve the accuracy and robustness.

All of these localization techniques are based on a centralized training model and they require transmission of sensitive information about users. However, with the increasing awareness about privacy and the policies for rules and regulations from legislative entities are restricting the reach to the sensitive user data. Hence a solution, such as federated learning is not only viable, but also required for future localization systems.

## III. PRIVACY-PRESERVING LOCALIZATION WITH FEDERATED LEARNING

### A. Data Preprocessing and Model Generation

In this paper, we consider a federated learning based *crowdsourcing* system for privacy-preserving indoor localization for a building scenario as seen in Fig.1. Let there be a set of  $k$  fixed access points (APs) as  $K$  which are broadcasting WiFi beacons in the building and a set of  $n$  users as  $N$  to gather RSS measurements from received

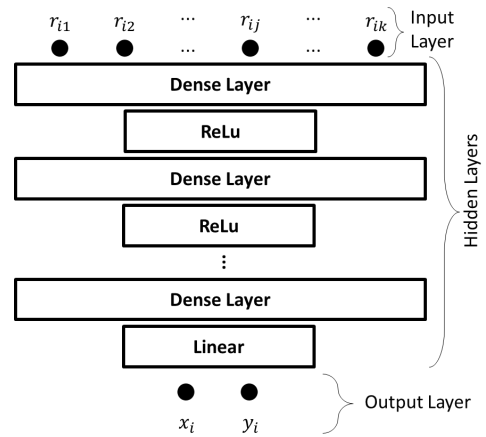

Fig. 2: Multilayer Perceptron generalized model.

beacons and label with them their location in cartesian coordinate  $(x, y)$ .

The initial global multilayer perceptron (MLP) model is generated based on a small amount of training data gathered for the centralized unit (i.e. server) to determine  $K$  (the set of fixed APs) for the building. Initially there will be a set of  $m$  samples of RSS measurements as  $M$  are collected labeled with the location information available at the server. Each sample  $i$  is an element in  $M$  includes  $l_i$  RSS measurements from a subset  $L_i$  of all  $k$  access points (i.e.  $L_i \subset K$ ). The RSS value of beacon from  $j$ th AP for  $i$ th sample is represented with  $r_{ij}$ . Hence the measurement vector for sample  $i$  can be defined as

$$\mathbf{s}_i = [r_{ij_1} \cdots r_{ij} \cdots r_{ij_{l_i}}], \forall i \in M, j \in L_i. \quad (1)$$

The labeling of  $i$ th sample is the location information which is the cartesian coordinates of the RSS measurement and represented as

$$\mathbf{y}_i = [x_i \ y_i]^T, \forall i \in M. \quad (2)$$

Thus, the initial multilayer perceptron (MLP) model has  $k$  nodes in the input layer which involves the vector of RSS values from WiFi beacons gathered and . In case of the beacon from any access point is not available, the RSS value is set to a constant value  $C$  for the corresponding input to MLP model. Hence the below equation represents the input vector for MLP model for sample  $i$

$$\mathbf{x}_i = [r_{i1} \cdots r_{ij} \cdots r_{ik}], \forall i \in \{1, \dots, m\}, \quad (3)$$

where

$$r_{ij} = C, \forall j \notin L_i. \quad (4)$$

The structure of global (MLP) model is given in Fig. 2. The global model may have various number of hidden nodes in various number of hidden (dense) layers. A variety of scenarios with different settings are explored in Section IV.

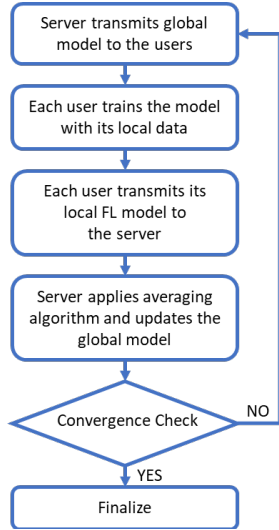

Fig. 3: Federated learning procedure.

After generation of the global model, it is trained with existing  $m$  samples. It can be shown as a minimization problem considering loss function  $f$  as below

$$\min_{\mathbf{w}} \frac{1}{m} \sum_{i=1}^m f(\mathbf{w}, \mathbf{x}_i, \mathbf{y}_i), \quad (5)$$

where  $\mathbf{w}$  is the model weights,  $m$  is number of training samples,  $\mathbf{x}_i$  is the  $i$ th input training sample, and  $\mathbf{y}_i$  is the label for  $i$ th sample.

This training works as an initializer, and it would result in a comparatively lower performance due to its small size. Consecutive step is transmitting global model to users for federated learning as explained in Section III-B.

### B. Federated Learning

The general procedure for Federated Learning is summarized in Fig. 3. The general model is transmitted to the users by the server. In each round,  $N$  users gather training data (RSS samples) from APs in the vicinity and label them with corresponding locations at different areas of the building. These users may change their positions, hence each measurement may consist beacons of different access points nearby at each sample. Subsequently, the users train the general model with their own data considering the minimization problem given in (5). Each user conveys its local model and its training size to the server. The server applies the federated weighted averaging and updates the global model based on local models of users.

$$\mathbf{w}^{t+1} = \frac{1}{H^t} \sum_{u=1}^N m_u^t \mathbf{w}_u^t, \quad (6)$$

$$H^t = \sum_{u=1}^n m_u^t, \quad (7)$$

where  $H$  is the total number of training samples,  $t$  is the round. After federated averaging is done, the global model is updated. Convergence of the federated averaging can be defined with

TABLE I: Federated Learning system parameters.

Parameter	Value
Deep Learning Libraries	Google TensorFlow & Keras
Optimizer	Adam [15]
Learning Rate	0.0001
$\beta_1, \beta_2$	0.1, 0.99
Hidden Layer Formation	20 x 10 x 10 x 10
Activation Function	ReLU
Loss Function	Mean Absolute Error
Number of Access Points (k)	520
Number of Users (n)	3 to 15
Number of Training Samples	3000 to 15000
Number of Test Samples	3000

several different methods, either checking the difference of  $\mathbf{w}^t$  at each round  $t$  or change in the loss function (i.e. early stopping mechanism).

## IV. NUMERICAL RESULTS

In this section, the performance of the proposed crowdsourcing method is benchmarked to centralized deep learning method in various settings and scenarios. Publicly available RSS data from UJIIndoorLoc database [14] is used to evaluate our federated learning-based localization system. The UJIIndoorLoc database includes 19937 samples distributed over 390 meters in length to 270 meters in width area over 4 floors for training and testing. It has RSS values from 520 distinct access points gathered labeled with timestamp and location information in longitude and latitude.

The simulation parameters for federated learning is summarized in Table I. TensorFlow and Keras libraries are utilized to implement proposed method. The optimizer is selected as Adam [15]. Learning rate and optimizer parameters are found with heuristic search and are as shown in Table I. Batch size and number of epochs for MLP learning are set to 1000 and 10 per round to avoid overfitting of the model. Three generic scenarios are simulated with UJIIndoorLoc database [14] to prove merits of our methodology. In all of the scenarios local models are generated without any data, hence randomly initialized for fair comparison with centralized training.

**Scenario-1:** The functionality of the proposed method is tested against centralized training method in the first scenario. A uniformly distributed dataset is divided into 1000 samples per user and proposed method is applied as discussed in Section III-B. The number of test dataset has 3000 samples in all scenarios uniformly distributed over the building, assumed to represent a real usecase. The centralized training method is used for benchmark for federated method. In the centralized training case instead of local models, local data is transferred to the centralized server, and the training done centrally.

**Scenario-2:** The functionality of the proposed method is tested against location heterogeneity of users in the second scenario. In this scenario instead of a uniformly distributed dataset over the building area, the building area is divided per user uniformly. Each user has the same amount of data, 1000 samples, but it is spatially divided for each user, thus each user covers a different region of the building. Although this ensures coverage of the building, it brings a challenge

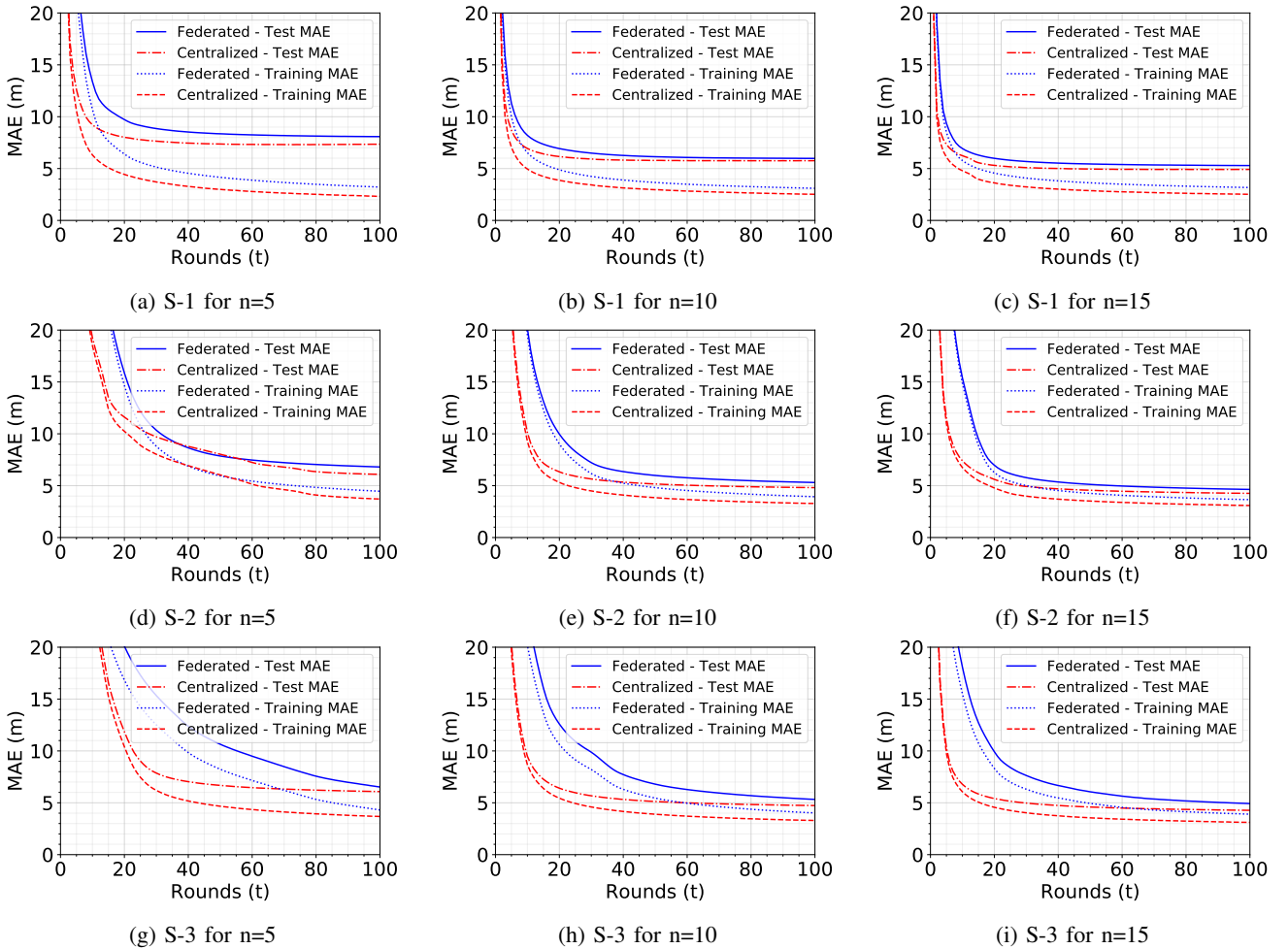

Fig. 4: Effect of number of users and various heterogeneity scenarios on accuracy and convergence time.

TABLE II: MAE (m) at round  $t=100$  for various scenarios.

Scenario	Federated Test	Centralized Test	Federated Training	Centralized Training
S-1 n=5	8.08	7.35	4.52	3.52
S-1 n=10	5.98	5.76	4.41	3.41
S-1 n=15	5.25	4.91	4.34	3.09
S-2 n=5	6.80	6.09	4.46	3.72
S-2 n=10	5.30	4.81	3.93	3.20
S-2 n=15	4.64	3.99	3.65	2.54
S-3 n=5	7.35	6.08	4.46	3.72
S-3 n=10	6.42	4.73	4.31	3.28
S-3 n=15	5.53	4.27	3.90	3.06

for machine learning model since different access points are available at different regions. It will significantly increase the convergence time.

**Scenario-3:** The functionality of the proposed method is tested against both location and training size heterogeneity similar to real world applications in the final scenario. In this realistic scenario, instead of the same amount of data per user as tested in Scenario-2, the amount of data per user is a random variable with a Gaussian distribution with 1000 samples as a mean and 500 as standard deviation with the limitation of at least 300 samples per user. Variation in the number of samples per user is another challenge for federated learning.

A summary of simulation results are provided in Table II. Mean absolute error (MAE) is an important metric for localization systems. Federated learning has below 5 meters MAE in simulations which is very reasonable considering the dimensions of the building (390 meters x 270 meters) provided in our dataset. The difference between centralized and federated learning is always lower than 1 meters for Scenario-1 and Scenario-2, and just above 1 meters for Scenario-3 due to its heterogeneous nature. Federated learning achieves better results with increasing number of users, closer to centralized learning.

Change in the MAE throughout rounds is shown for Scenario-1 is given in Fig. 4(a) to Fig. 4(c) with 5,10, and 15 users. Uniformly distributed data causes early convergence and overfitting afterwards, hence resulting high training accuracy and lower test accuracy. For example, the federated model converges around 40 rounds with 15 users, and the gap between training and test accuracy increases afterwards for both centralized and federated models.

The effect of location heterogeneity on MAE is presented in Fig.4(d) to Fig. 4(f). Note that, the heterogeneity affects both centralized and federated training, as well as increasing the convergence time. The ramifications of overfitting is

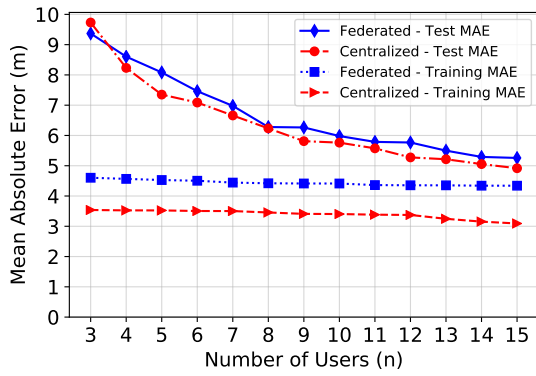

(a) Scenario-1 for t=100

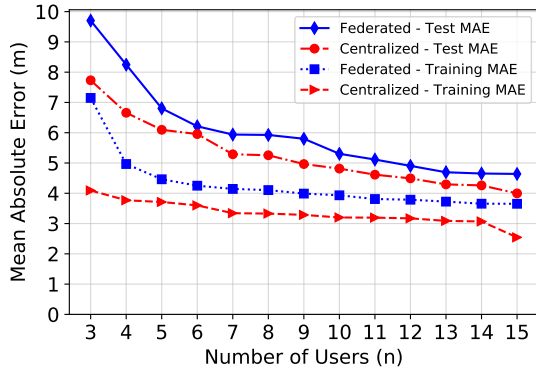

(b) Scenario-2 for t=100

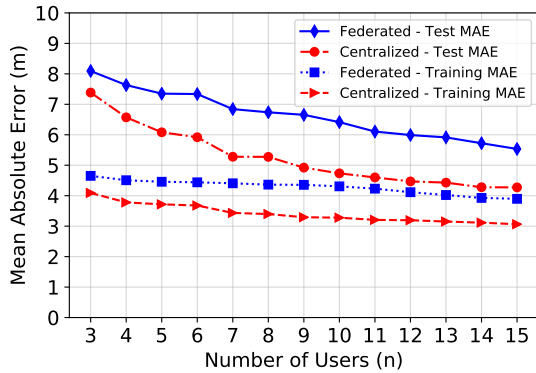

(c) Scenario-3 for t=100

Fig. 5: Effect of number of users and various heterogeneity scenarios on accuracy.

less visible since federated averaging handles heterogeneous models, which eventually increases variance in the global model, and reduces the bias. It can be seen that although training accuracy is lower than uniform case, the test accuracy is higher due to avoidance of overfitting.

Heterogeneity in the number of training samples is a challenge for Federated Learning [7]. Performance of the federated learning method for localization is tested against this challenge in Scenario-3. In Fig.4(g) to Fig.4(i), it is shown that increasing heterogeneity increases convergence time and lowers the accuracy. However, with enough number of users, the error eventually drops. The MAE is 5.53 with 15 users.

Effect of number of users on federated learning localization accuracy is shown in Fig. 5. It is shown that the training error of centralized method (3.52 meters) is relatively lower compared to training error of federated method (4.52 meters) for 5 users in the system ( $n = 5$ ) for Scenario-1. Federated method is close to centralized method in both training and test accuracy for Scenario-1 as it has the least heterogeneity. Federated learning performs a considerable performance compared to centralized learning. The difference between them is smaller than 1 meter when there is 5 or more users considering mean absolute error for test dataset.

Increasing heterogeneity by introducing location-based clustering for users increased the convergence time of federated algorithm, however it improved the localization accuracy in general. Federated learning-based localization could achieve 4.64 meters compared to 3.99 meters of centralized version in Scenario-2 as in Fig.4(b). The heterogeneity in the training size, number of samples per user, caused a drop in the performance of the algorithm as expected. However, it still achieves accuracy close to centralized training.

Scenario-3 has the most challenging task for the proposed method as shown in Fig.5(c). The MAE is 5.53 meters for federated model compared to 4.27 meters of centralized model for test dataset. One should note that, the reason behind this gap is increased convergence time, and federated model reduces the gap less than 1 meter after several rounds past 100 rounds.

Another observation is that, the private data that would turn into dust can be highly utilized with federated learning as proposed. Consider that centralized server has only 5000 samples, which achieves 7.35 meters of accuracy initially. Allowing 5 users to contribute with 1000 samples each, drops the MAE to 5.98 meters on the average, which is 16% improvement in the localization accuracy with preserving privacy of the users.

## V. CONCLUSION

In this paper, we propose a federated-learning-based technique to provide privacy-preserving crowdsourcing for localization. The proposed method assures the utilization of the private local data by keeping the data at where it is generated and only sharing the local models with centralized unit and the global model with edge devices, iteratively. We explored the effect of sample-size and location heterogeneity on the performance of federated learning.

In our experimental results, we are able to localize users within 4.64 meters accuracy in a 390 meters to 270 meters building. We are also able to improve the performance of the centralized training 16% by boosting it with federated learning. In general, we show that federated learning has the ability to perform well in consideration of crowdsourcing for localization under various settings while preserving-privacy of the users.

## REFERENCES

- [1] C. Zhang, P. Patras, and H. Haddadi, "Deep learning in mobile and wireless networking: A survey," *IEEE Communications Surveys Tutorials*, vol. 21, no. 3, pp. 2224–2287, thirdquarter 2019.
- [2] F. Zafari, A. Gkelias, and K. K. Leung, "A survey of indoor localization systems and technologies," *IEEE Communications Surveys Tutorials*, vol. 21, no. 3, pp. 2568–2599, thirdquarter 2019.
- [3] X. Wang, L. Gao, S. Mao, and S. Pandey, "CSI-based fingerprinting for indoor localization: A deep learning approach," *IEEE Transactions on Vehicular Technology*, vol. 66, no. 1, pp. 763–776, Jan 2017.
- [4] M. S. Rahman, Y. Park, and K.-D. Kim, "RSS-based indoor localization algorithm for wireless sensor network using generalized regression neural network," *Arabian Journal for Science and Engineering*, vol. 37, no. 4, pp. 1043–1053, Jun 2012. [Online]. Available: <https://doi.org/10.1007/s13369-012-0218-1>
- [5] S. He and S. . G. Chan, "Wi-Fi fingerprint-based indoor positioning: Recent advances and comparisons," *IEEE Communications Surveys Tutorials*, vol. 18, no. 1, pp. 466–490, Firstquarter 2016.
- [6] C. Wu, Z. Yang, and Y. Liu, "Smartphones based crowdsourcing for indoor localization," *IEEE Transactions on Mobile Computing*, vol. 14, no. 2, pp. 444–457, Feb 2015.
- [7] H. B. McMahan, E. Moore, D. Ramage, S. Hampson, and B. A. y Arcas, "Communication-efficient learning of deep networks from decentralized data," 2016.
- [8] S. Niknam, H. S. Dhillon, and J. H. Reed, "Federated learning for wireless communications: Motivation, opportunities and challenges," *arXiv preprint arXiv:1908.06847*, 2019.
- [9] J. Park, S. Samarakoon, M. Bennis, and M. Debbah, "Wireless network intelligence at the edge," *arXiv preprint arXiv:1812.02858*, 2018.
- [10] M. Youssef and A. Agrawala, "The Horus WLAN location determination system," in *Proceedings of the 3rd international conference on Mobile systems, applications, and services*. ACM, 2005, pp. 205–218.
- [11] M. Brunato and R. Battiti, "Statistical learning theory for location fingerprinting in wireless lans," *Computer Networks*, vol. 47, no. 6, pp. 825–845, 2005.
- [12] X. Wang, L. Gao, and S. Mao, "CSI phase fingerprinting for indoor localization with a deep learning approach," *IEEE Internet of Things Journal*, vol. 3, no. 6, pp. 1113–1123, Dec 2016.
- [13] X. Wang, X. Wang, and S. Mao, "Deep convolutional neural networks for indoor localization with CSI images," *IEEE Transactions on Network Science and Engineering*, pp. 1–1, 2018.
- [14] J. Torres-Sospedra, R. Montoliu, A. Martnez-U, J. P. Avariento, T. J. Arnau, M. Benedito-Bordonau, and J. Huerta, "UJIIndoorLoc: A new multi-building and multi-floor database for WLAN fingerprint-based indoor localization problems," in *2014 Int. Conf. on Indoor Positioning and Indoor Navigation (IPIN)*, Oct 2014, pp. 261–270.
- [15] D. P. Kingma and J. Ba, "Adam: A method for stochastic optimization," 2014.