

# The Complexity of Verifying Circuits as Differentially Private

Marco Gaboardi<sup>1</sup>, Kobbi Nissim<sup>2</sup>, and David Purser<sup>3</sup>

<sup>1</sup> Boston University, USA [gaboardi@bu.edu](mailto:gaboardi@bu.edu)

<sup>2</sup> Georgetown University, USA [kobbi.nissim@georgetown.edu](mailto:kobbi.nissim@georgetown.edu)

<sup>3</sup> University of Warwick, UK [D.J.Purser@warwick.ac.uk](mailto:D.J.Purser@warwick.ac.uk)

**Abstract.** We study the problem of verifying differential privacy for straight line programs with probabilistic choice. Programs in this class can be seen as randomized Boolean circuits. We focus on two different questions: first, deciding whether a program satisfies a prescribed level of privacy; second, approximating the privacy parameters a program realizes. We show that the problem of deciding whether a program satisfies  $\epsilon$ -differential privacy is  $\mathbf{coNP}^{\#P}$ -complete. In fact, this is the case when either the input domain or the output range of the program is large. Further, we show that deciding whether a program is  $(\epsilon, \delta)$ -differentially private is  $\mathbf{coNP}^{\#P}$ -hard, and in  $\mathbf{coNP}^{\#P}$  for small output domains, but always in  $\mathbf{coNP}^{\#P^{\#P}}$ . Finally, we show that the problem of approximating the level of differential privacy is both  $\mathbf{NP}$ -hard and  $\mathbf{coNP}$ -hard.

**Keywords:** differential privacy · program verification · probabilistic circuits

## 1 Introduction

Differential privacy [19] is currently making significant strides towards being used in large scale real-world applications. Prominent examples include the use of differentially private computations by the US Census’ OnTheMap project<sup>4</sup>, applications by companies such as Google and Apple [21,28,4,16], and the US Census’ plan to deploy differentially private releases in the upcoming 2020 Decennial [1].

More often than not, algorithms and their implementations are analyzed “on paper” to show that they provide differential privacy. This analysis—a proof that the outcome distribution of the algorithm is stable under the change in any single individual’s information—is often intricate and may contain errors (see [24] for an illuminating discussion about several wrong versions of the sparse vector algorithm appeared in the literature). Moreover, even if it is actually differentially private, an algorithm may be incorrectly implemented when used in practice, e.g. due to coding errors, or because the analysis makes assumptions which do not hold in finite computers, such as the ability to sample from continuous distributions (see [26] for a discussion about privacy attacks on naive implementations of continuous distributions). Verification tools may help validate, given the code of an implementation, that it would indeed provide the privacy guarantees it is intended to provide. However, despite the many verification efforts that have targeted differential privacy, e.g. [29,8,32,22,6,36,5,2,13,14] based on automated or interactive techniques, little is known about the complexity of some of the basic problems in this area. Our aim is to clarify the complexity of some of these problems.

In this paper, we consider the computational complexity of determining whether programs satisfy  $(\epsilon, \delta)$ -differential privacy. The problem is generally undecidable, and we hence restrict our attention to probabilistic straight line programs, which are part of any reasonable programming language supporting random computations. Equivalently, we consider

<sup>4</sup> <https://onthemap.ces.census.gov>

probabilistic circuits. The latter are Boolean circuits with input nodes corresponding both to input bits and to uniformly random bits (“coin flips”) where the latter allow the circuit to behave probabilistically (see Figure 1). We consider both decision and approximation versions of the problem, where in the case of decision the input consists of a randomized circuit and parameters  $\varepsilon, \delta$  and in the case of approximation the input is a randomized circuit, the desired approximation precision, and one of the two parameters  $\varepsilon, \delta$ . In both cases, complexity is measured as function of the total input length in bits.

Our work is also motivated by the work by Murtagh and Vadhan [27] studying the complexity of optimally compose differentially private algorithms. It is known that the composition of differentially private computations also satisfies differential privacy [19,20,27]. Consider the composition of  $k$  differentially private algorithms with privacy parameters  $(\varepsilon_1, \delta_1), \dots, (\varepsilon_k, \delta_k)$ . The resulting program is  $(\varepsilon_g, \delta_g)$ -differentially private for a multitude of possible  $(\varepsilon_g, \delta_g)$  pairs. Murtagh and Vadhan showed that determining the minimal  $\varepsilon_g$  given  $\delta_g$  is  $\#\mathbf{P}$ -complete [27]. They also give a polynomial time approximation algorithm that computes  $\varepsilon_g$  to arbitrary accuracy, giving hope that for “simple” programs deciding differential privacy or approximating of privacy parameters may be tractable. Our results show that this is not the case.

## 1.1 Contributions

Following the literature, we refer to the variant of differential privacy where  $\delta = 0$  as *pure* differential privacy and to the variant where  $\delta > 0$  as *approximate* differential privacy. We contribute in three directions.

- **Verifying pure differential privacy.** We show that determining whether a randomized circuit is  $\varepsilon$ -differentially private is  $\mathbf{coNP}^{\#\mathbf{P}}$ -complete.<sup>5</sup> To show hardness in  $\mathbf{coNP}^{\#\mathbf{P}}$  we consider a complement to the problem E-MAJ-SAT [23], which is complete for  $\mathbf{NP}^{\#\mathbf{P}}$  [12]. In the complementary problem, ALL-MIN-SAT, given a formula  $\phi$  over  $n+m$  variables the task is to determine if for all allocations  $\mathbf{x} \in \{0, 1\}^n$ ,  $\phi(\mathbf{x}, \mathbf{y})$  evaluates to true on no more than  $\frac{1}{2}$  of allocations to  $\mathbf{y} \in \{0, 1\}^m$ .
- **Verifying approximate differential privacy.** Turning to the case where  $\delta > 0$ , we show that determining whether a randomized circuit is  $(\varepsilon, \delta)$ -differentially private is  $\mathbf{coNP}^{\#\mathbf{P}}$ -complete when the number of output bits is small relative to the total size of the circuit and otherwise between  $\mathbf{coNP}^{\#\mathbf{P}}$  and  $\mathbf{coNP}^{\#\mathbf{P}^{\#\mathbf{P}}}$ .
- **Approximating the parameters  $\varepsilon$  and  $\delta$ .** Efficient approximation algorithms exist for optimal composition [27], and one might expect the existence of polynomial time algorithms to approximate  $\varepsilon$  or  $\delta$ . We show this is  $\mathbf{NP}$ -hard and  $\mathbf{coNP}$ -hard, and therefore an efficient algorithm does not exist (unless  $\mathbf{P} = \mathbf{NP}$ ).

Our results show that for straight line programs with probabilistic choice directly verifying whether a program is differentially private is intractable. These results apply to programs in any reasonable programming language supporting randomized computations. Hence, they set the limits on where to search for automated techniques for these tasks.

## 1.2 Related work

Differential privacy was introduced in [19]. It is a definition of privacy in the context of data analysis capturing the intuition that information specific to an individuals is protected if

<sup>5</sup> The class  $\mathbf{coNP}^{\#\mathbf{P}}$  is contained in  $\mathbf{PSPACE}$  and contains the polynomial hierarchy (as, per Toda’s Theorem  $\mathbf{PH} \subseteq \mathbf{P}^{\#\mathbf{P}}$ ).

every single user’s input has a bounded influence on the computation’s outcome distribution, where the bound is specified by two parameters, usually denoted by  $\varepsilon, \delta$ . Intuitively, these parameters set an upperbound on privacy loss, where the parameter  $\varepsilon$  limits the loss and the parameter  $\delta$  limits the probability in which the loss may exceed  $\varepsilon$ .

Extensive work has occurred in the computer-assisted or automated of verification of differential privacy. Early work includes, PINQ [25] and Airavat [30] which are systems that keep track of the privacy budgets ( $\varepsilon$  and  $\delta$ ) using trusted privacy primitives in SQL-like and MapReduce-like paradigms respectively. In other work, programming languages were developed, that use the type system to keep track of the sensitivity and ensure the correct level of noise is added [29,8,15,7]. Another line of work uses proof assistants to help prove that an algorithm is differentially private [6]; although much of this work is not automated, recent work has gone in this direction [2,36].

These techniques focuses on ‘soundness’, rather than ‘completeness’ thus are not amenable to complexity analysis. In the constrained case of verifying differential privacy on probabilistic automata and Markov chains there are bisimulation based techniques [32,11]. Towards complexity analysis; [14] shows that computing the optimal value of  $\delta$  for a finite labelled Markov chain is undecidable. Further [13] and [14] provides distances, which are (necessarily) not tight, but can be computed in polynomial time with an **NP** oracle and a weaker bound in polynomial time. Recent works have focused on developing techniques for finding violations of differential privacy [17,9]. The methods proposed so far have been based on some form of testing. Our result limits also the tractability of these approaches.

As we already discussed, Murtagh and Vadhan [27] showed that finding the optimal values for the privacy parameters when composing different algorithms in a black-box way is  $\#\mathbf{P}$ -complete, but also that approximating the optimal values can be done efficiently. In contrast, our results show that when one wants to consider programs as white-box, as often needed to achieve better privacy guarantees (e.g. in the case of the sparse vector technique), the complexity is higher.

*The relation to quantitative information flow.* Differential privacy has similarities with quantitative probabilistic information flow [3], which is an entropy-based theory measuring how secure a program is. Checking that a program does not have probabilistic information flow is equivalent to checking that a program is 0-differentially private. For loop free boolean programs with probabilistic choice, this problem is **coNP**-complete [35]. Comparing the quantitative information flow of two programs on inputs coming from the uniform distribution is  $\#\mathbf{P}$ -hard [35]. However, when quantifying over all distributions the question is **coNP**-complete [35]. Checking whether the quantitative information flow of a program is less than a threshold has been shown to be **PP**-hard[34] (but in **PSPACE**) for loop-free boolean programs and to be **PSPACE**-complete for boolean programs with loops [10].

## 2 Preliminaries

*Numbers.* By a *number given as a rational* we mean a number of the form  $\frac{x}{y}$  where  $x, y$  are given as binary integers. By *number given in binary* we mean a number of the form  $\frac{x}{2^y}$ , where  $x$  is given in binary and  $y$  is indicated by the position of the ‘.’. For example  $1.15625_{10} = 1.00101_2 = \frac{100101_2}{2^5} = \frac{37}{2^5}$ .

### 2.1 Probabilistic Circuits

**Definition 1.** A Boolean circuit  $\psi$  with  $n$  inputs and  $\ell$  outputs is a directed acyclic graph  $\psi = (V, E)$  containing  $n$  input vertices with zero in-degree, labeled  $X_1, \dots, X_n$  and  $\ell$  out-

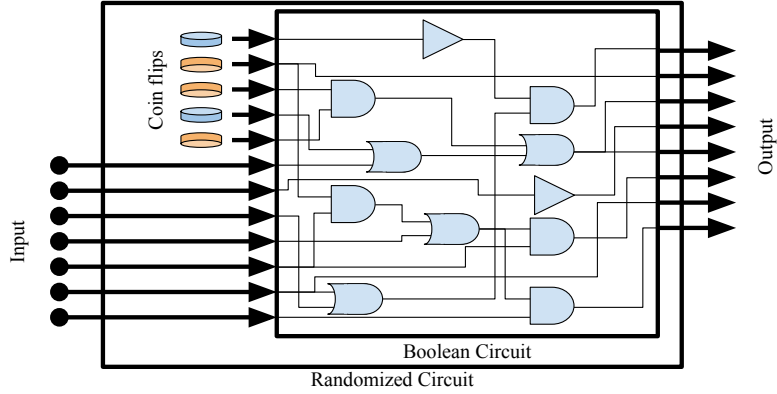

**Fig. 1.** Example randomized circuit

put vertices with zero out-degree, labeled  $O_1, \dots, O_\ell$ . Other nodes are assigned a label in  $\{\wedge, \vee, \neg\}$ , with vertices labeled  $\neg$  having in-degree one and all others having in-degree two. The size of  $\psi$ , denoted  $|\psi|$ , is defined to be  $|V|$ . A randomized circuit has  $m$  additional random input vertices labeled  $R_1, \dots, R_m$ .

Given an input string  $\mathbf{x} = (x_1, \dots, x_n) \in \{0, 1\}^n$ , the circuit is evaluated as follows. First, the values  $x_1, \dots, x_n$  are assigned to the nodes labeled  $X_1, \dots, X_n$ . Then,  $m$  bits  $\mathbf{r} = (r_1, \dots, r_m)$  are sampled uniformly at random from  $\{0, 1\}^m$  and assigned to the nodes labeled  $R_1, \dots, R_m$ . Then, the circuit is evaluated in topological order in the natural way. E.g., let  $v$  be a node labeled  $\wedge$  with incoming edges  $(u_1, v), (u_2, v)$  where  $u_1, u_2$  were assigned values  $z_1, z_2$  then  $v$  is assigned the value  $z_1 \wedge z_2$ . The outcome of  $\psi$  is  $(o_1, \dots, o_\ell)$ , the concatenation of values assigned to the  $\ell$  output vertices  $O_1, \dots, O_\ell$ .

For input  $\mathbf{x} \in \{0, 1\}^n$  and event  $E \subseteq \{0, 1\}^\ell$  we have

$$\Pr[\psi(\mathbf{x}) \in E] = \frac{|\{\mathbf{r} \in \{0, 1\}^m : \psi(\mathbf{x}, \mathbf{r}) \in E\}|}{2^m}.$$

*Remark 1.* The operators,  $\wedge, \vee$  and  $\neg$  are functionally complete. However, we will also use  $\oplus$  (exclusive or), such that  $p \oplus q \iff (p \vee q) \wedge \neg(p \wedge q)$ .

## 2.2 Differential Privacy in Probabilistic Circuits

Let  $X$  be any input domain. An input to a differentially private analysis would generally be an array of elements from  $X$ , i.e.,  $\mathbf{x} = (x_1, \dots, x_n) \in X^n$ .

The definition of differential privacy depends on adjacency between inputs, we define *neighboring* inputs.

**Definition 2.** Inputs  $\mathbf{x} = (x_1, \dots, x_n)$  and  $\mathbf{x}' = (x'_1, \dots, x'_n) \in X^n$  are called neighboring if there exist  $i \in [n]$  s.t. for all  $j \neq i$  then  $x_j = x'_j$ .

In this work, we will consider input domains with finite representation. Without loss of generality we set  $X = \{0, 1\}^k$  and hence an array  $x = (x_1, \dots, x_n)$  can be written as a sequence of  $nk$  bits, and given as input to a (randomized) circuit with  $nk$  inputs. Our lower bounds work already for for  $k = 1$  and our upper bounds are presented using  $k = 1$  but generalise to all  $k$ .

**Definition 3 (Differential Privacy [19,18]).** A probabilistic circuit  $\psi$  is  $(\varepsilon, \delta)$ -differentially private if for all neighboring  $\mathbf{x}, \mathbf{x}' \in X^n$  and for all  $E \subseteq \{0, 1\}^\ell$ ,

$$\Pr[\psi(\mathbf{x}) \in E] \leq e^\varepsilon \cdot \Pr[\psi(\mathbf{x}') \in E] + \delta.$$

Following common use, we refer to the case where  $\delta = 0$  as *pure* differential privacy and to the case where  $\delta > 0$  as *approximate* differential privacy. When omitted,  $\delta$  is understood to be zero.

### 2.3 Problems of deciding and approximating differential privacy

We formally define our three problems of interest.

**Definition 4.** The problem DECIDE- $\varepsilon$ -DP asks, given  $\varepsilon$  and  $\psi$ , if  $\psi$  is  $\varepsilon$ -differentially private. We assume  $\varepsilon$  is given by the input  $e^\varepsilon$  given in binary<sup>6</sup>.

**Definition 5.** The problem DECIDE- $\varepsilon, \delta$ -DP asks, given  $\varepsilon, \delta$  and  $\psi$ , if  $\psi$  is  $(\varepsilon, \delta)$ -differentially private. We assume  $\varepsilon$  is given by the input  $e^\varepsilon$  in binary.

**Definition 6.** Given an approximation error  $\gamma > 0$ , the APPROXIMATE- $\delta$  problem and the APPROXIMATE- $\varepsilon$  problem, respectively, ask:

- Given  $\varepsilon$ , find  $\hat{\delta} \in [0, 1]$ , such that  $0 \leq \hat{\delta} - \delta \leq \gamma$ , where  $\delta$  is the minimal value such that  $\psi$  is  $(\varepsilon, \delta)$ -differentially private.
- Given  $\delta$ , find  $\hat{\varepsilon} \geq 0$ , such that  $0 \leq \hat{\varepsilon} - \varepsilon \leq \gamma$ , where  $\varepsilon$  is the minimal value such that  $\psi$  is  $(\varepsilon, \delta)$ -differentially private.

### 2.4 The class $\text{coNP}^{\#\mathbf{P}}$

A language  $L$  is in  $\text{coNP}^{\#\mathbf{P}}$  if its problem membership can be refuted using a polynomial time non-deterministic Turing machine with access to a  $\#\mathbf{P}$  oracle. Alternatively,  $x \in L$  iff *all* branches of the non-deterministic Turing machine accept. It is easy to see that  $\text{coNP}^{\#\mathbf{P}} = \text{coNP}^{\text{PP}}$ . Finally,  $\mathbf{PH} \subseteq \text{coNP}^{\#\mathbf{P}} \subseteq \text{PSPACE}$ , where  $\mathbf{PH} \subseteq \text{coNP}^{\#\mathbf{P}}$  follows by Toda's theorem ( $\mathbf{PH} \subseteq \mathbf{P}^{\#\mathbf{P}}$ ) [31].

The following decision problem is complete for  $\text{NP}^{\#\mathbf{P}}$  [12]:

**Definition 7.** E-MAJ-SAT asks, given  $\phi$  a quantifier free formula over  $n + m$  variables if there exist an allocation  $\mathbf{x} \in \{0, 1\}^n$  such that there are strictly greater than  $\frac{1}{2}$  of allocations to  $\mathbf{y} \in \{0, 1\}^m$  where  $\phi(\mathbf{x}, \mathbf{y})$  evaluates to true.

The complementary problem ALL-MIN-SAT, is complete for  $\text{coNP}^{\#\mathbf{P}}$ : a formula  $\phi$  is ALL-MIN-SAT, if  $\phi$  is not E-MAJ-SAT. That is,  $\phi$  a quantifier free formula over  $n + m$  variables is ALL-MIN-SAT if for all allocations  $\mathbf{x} \in \{0, 1\}^n$  there are no more than  $\frac{1}{2}$  of allocations to  $\mathbf{y} \in \{0, 1\}^m$  where  $\phi(\mathbf{x}, \mathbf{y})$  evaluates to true.

## 3 The complexity of deciding pure differential privacy

In this section we classify the complexity of deciding  $\varepsilon$ -differential privacy, for which we show the following theorem:

**Theorem 1.** DECIDE- $\varepsilon$ -DP is  $\text{coNP}^{\#\mathbf{P}}$ -complete.

<sup>6</sup> For this specific problem, our results apply if  $e^\varepsilon$  is given as a rational number.

It will be convenient to consider the well-known simpler reformulation of the definition of pure differential privacy in finite ranges to consider specific outcomes  $\mathbf{o} \in \{0, 1\}^\ell$  rather than events  $E \subseteq \{0, 1\}^\ell$ .

**Reformulation 1 (Pure differential privacy)** *A probabilistic circuit  $\psi$  is  $\varepsilon$ -differentially private if and only if for all neighboring  $\mathbf{x}, \mathbf{x}' \in X^n$  and for all  $\mathbf{o} \in \{0, 1\}^\ell$ ,*

$$\Pr[\psi(\mathbf{x}) = \mathbf{o}] \leq e^\varepsilon \cdot \Pr[\psi(\mathbf{x}') = \mathbf{o}].$$

**DECIDE- $\varepsilon$ -DP  $\in$   $\mathbf{coNP}^{\#\mathbf{P}}$ :** We show a non-deterministic Turing machine which can ‘refute’  $\psi$  being  $\varepsilon$ -differentially private in polynomial time with a  $\#\mathbf{P}$  oracle. A circuit  $\psi$  is shown not to be  $\varepsilon$ -differentially private by exhibiting a combination  $\mathbf{x}, \mathbf{x}', \mathbf{o}$  such that  $\Pr[\psi(\mathbf{x}) = \mathbf{o}] > e^\varepsilon \cdot \Pr[\psi(\mathbf{x}') = \mathbf{o}]$ . The witness to the non-deterministic Turing machine would be a sequence of  $2n$  bits parsed as neighboring inputs  $\mathbf{x}, \mathbf{x}' \in \{0, 1\}^n$  and  $\ell$  bits describing an output  $\mathbf{o} \in \{0, 1\}^\ell$ . The constraint can then be checked in polynomial time, using the  $\#\mathbf{P}$  oracle to compute  $\Pr[\psi(\mathbf{x}) = \mathbf{o}]$  and  $\Pr[\psi(\mathbf{x}') = \mathbf{o}]$ .

To compute  $\Pr[\psi(\mathbf{x}) = \mathbf{o}]$  in  $\#\mathbf{P}$  we create an instance to  $\#\mathbf{CIRCUITSAT}$ , which will count the number of allocations to the  $m$  probabilistic bits consistent with this output. We do this by extending  $\psi$  with additional gates reducing to a single output which is true only when the input is fixed to  $\mathbf{x}$  and the output of  $\psi$  was  $\mathbf{o}$ .

### 3.1 $\mathbf{coNP}^{\#\mathbf{P}}$ -hardness of DECIDE- $\varepsilon$ -DP

To show  $\mathbf{coNP}^{\#\mathbf{P}}$ -hardness of DECIDE- $\varepsilon$ -DP we show a reduction from ALL-MIN-SAT in Lemma 1; together with the inclusion result above, this entails that DECIDE- $\varepsilon$ -DP is  $\mathbf{coNP}^{\#\mathbf{P}}$ -complete (Theorem 1).

*Randomized Response* Randomized response [33] is a technique for answering sensitive Yes/No questions by flipping the answer with probability  $p < 0.5$ . Setting  $p = \frac{1}{1+e^\varepsilon}$  gives  $\varepsilon$ -differential privacy.

**Lemma 1.** ALL-MIN-SAT reduces in polynomial time to DECIDE- $\varepsilon$ -DP.

*Proof.* We will reduce from ALL-MIN-SAT to DECIDE- $\varepsilon$ -DP using randomized response. We will take a boolean formula  $\phi$  and create a probabilistic circuit that is  $\varepsilon$ -differentially private if and only if  $\phi$  is ALL-MIN-SAT.

Consider the circuit  $\psi$  which takes as input the value  $z \in \{0, 1\}$ . It probabilistically chooses a value of  $\mathbf{x} \in \{0, 1\}^n$  and  $\mathbf{y} \in \{0, 1\}^m$  and one further random bit  $p_1$  and computes  $b = z \oplus \neg(p_1 \vee \phi(\mathbf{x}, \mathbf{y}))$ . The circuit outputs  $(\mathbf{x}, b)$ .

*Claim.*  $\psi$  is  $\ln(3)$ -differentially private if and only if  $\phi$  is ALL-MIN-SAT.

Suppose  $\phi \in$  ALL-MIN-SAT then, no matter the choice of  $x$ ,

$$0 \leq \Pr_{\mathbf{y}}[\phi(\mathbf{x}, \mathbf{y}) = 1] \leq \frac{1}{2} \quad \text{and hence} \quad \frac{1}{4} \leq \Pr_{\mathbf{y}, p_1}[\neg(p_1 \vee \phi(\mathbf{x}, \mathbf{y})) = 1] \leq \frac{1}{2}.$$

We conclude the true answer  $z$  is flipped between  $\frac{1}{4}$  and  $\frac{1}{2}$  of the time, recall this is exactly the region in which randomized response gives us the most privacy. In the worst case  $p = \frac{1}{4} = \frac{1}{1+e^\varepsilon}$ , gives  $e^\varepsilon = 3$ , so  $\ln(3)$ -differential privacy.

In the converse, suppose  $\phi \in$  E-MAJ-SAT, then for some  $\mathbf{x}$  then  $\Pr_{\mathbf{y}, p_1}[\neg(p_1 \vee \phi(\mathbf{x}, \mathbf{y})) = 1] < \frac{1}{4}$ , in which case the randomized response does not provide  $\ln(3)$ -differential privacy.  $\square$

*Remark 2.* We skew the result so that the proportion of accepting allocations is between  $\frac{1}{4}$  and  $\frac{1}{2}$  to satisfy privacy, resulting in the choice of  $\ln(3)$ -differentially privacy. Alternative skews, using more bits akin to  $p_1$ , shows hardness for other choices of  $\varepsilon$ .

*Remark 3.* In our inclusion proof we use **coNP** to resolve the non-deterministic choice of both input and output. We show this is necessary in the sense **coNP** is still required for either large input or large output. The hardness proof shows that when  $|\psi| = n$  the problem is hard for  $O(1)$ -bit input and  $O(n)$ -bit output. We can also prove (Lemma 5 in the appendix) this is hard for  $O(n)$ -bit input and  $O(1)$ -bit output. Further the problem is in **P<sup>#P</sup>** for  $O(\log(n))$ -bit input and  $O(\log(n))$ -bit output, as the choice made by **coNP** can be checked deterministically. In this case it is **PP**-hard, even when there is 1-bit input and 1-bit output.

## 4 On the complexity of deciding approximate differential privacy

Theorem 1 shows that **DECIDE- $\varepsilon$ -DP** is **coNP<sup>#P</sup>**-complete, in particular **coNP<sup>#P</sup>**-hard and since **DECIDE- $\varepsilon$ -DP** is a special case of **DECIDE- $\varepsilon, \delta$ -DP**, this is also **coNP<sup>#P</sup>**-hard. Nevertheless the proof is based on particular values of  $\varepsilon$  and we provide an alternative proof of hardness (Theorem 3 in the appendix) based on  $\delta$  (which applies even for  $\varepsilon = 0$ ).

It is less clear whether deciding  $(\varepsilon, \delta)$ -differential privacy can be done in **coNP<sup>#P</sup>**. Recall that in the case of  $\varepsilon$ -differential privacy it was enough to consider singleton events  $\{\mathbf{o}\}$  where  $\mathbf{o} \in \{0, 1\}^\ell$ , however in the definition of  $(\varepsilon, \delta)$ -differential privacy we must quantify over output events  $E \subseteq \{0, 1\}^\ell$ . If we consider circuits with one output bit ( $\ell = 1$ ), then the event space essentially reduces to  $E \in \{\emptyset, \{0\}, \{1\}, \{0, 1\}\}$  and we can apply the same technique.

We expand this to the case when the number of outputs bits is logarithmic  $\ell \leq \log(|\psi|)$ . To cater to this, rather than guessing a violating  $E \in \{0, 1\}^\ell$ , we consider a violating subset of events  $E \subseteq \{0, 1\}^\ell$ . Given such an event  $E$  we create a circuit  $\psi_E$  on  $\ell$  inputs and a single output which indicates whether the input is in the event  $E$ . The size of this circuit is exponential in  $\ell$ , thus polynomial in  $|\psi|$ . Composing  $\psi_E \circ \psi$ , we check the conditions hold for this event  $E$ , with just one bit of output.

*Claim.* **DECIDE- $\varepsilon, \delta$ -DP**, restricted to circuits  $\psi$  with  $\ell$  bit outputs where  $\ell \leq \log(|\psi|)$ , is in **coNP<sup>#P</sup>** (and hence **coNP<sup>#P</sup>**-complete).

The claim trivially extends to  $\ell \leq c \cdot \log(|\psi|)$  for any fixed  $c > 0$ .

### 4.1 **DECIDE- $\varepsilon, \delta$ -DP** $\in$ **coNP<sup>#P#P</sup>**

We now show that **DECIDE- $\varepsilon, \delta$ -DP** in the most general case can be solved in **coNP<sup>#P#P</sup>**. We will assume  $e^\varepsilon = \alpha$  is given in binary, thus  $\alpha = \frac{u}{2^v}$  for some integers  $u$  and  $v$ . While we will use non-determinism to choose inputs leading to a violating event, unlike in Section 3 it would not be used for finding a violating event  $E$ , as an (explicit) description of such an event may be of super-polynomial length. It would be useful for us to use a reformulation of approximate differential privacy, using a sum over potential individual outcomes.

**Reformulation 2 (Pointwise differential privacy [6])** *A probabilistic circuit  $\psi$  is  $(\varepsilon, \delta)$ -differentially private if and only if for all neighboring  $\mathbf{x}, \mathbf{x}' \in X^n$  and for all  $\mathbf{o} \in \{0, 1\}^\ell$ ,*

$$\sum_{\mathbf{o} \in \{0, 1\}^\ell} \delta_{\mathbf{x}, \mathbf{x}'}(\mathbf{o}) \leq \delta, \quad \text{where} \quad \delta_{\mathbf{x}, \mathbf{x}'}(\mathbf{o}) = \max(\Pr[\psi(\mathbf{x}) = \mathbf{o}] - e^\varepsilon \cdot \Pr[\psi(\mathbf{x}') = \mathbf{o}], 0).$$

We define  $\mathcal{M}$ , a non-deterministic Turing Machine with access to a  $\#\mathbf{P}$ -oracle, and where each execution branch runs in polynomial time. On inputs a probabilistic circuit  $\psi$  and neighboring  $\mathbf{x}, \mathbf{x}' \in X^n$  the number of accepting executions of  $\mathcal{M}$  would be proportional to  $\sum_{\mathbf{o} \in \{0,1\}^\ell} \delta_{\mathbf{x}, \mathbf{x}'}(\mathbf{o})$ .

In more detail, on inputs  $\psi$ ,  $\mathbf{x}$  and  $\mathbf{x}'$ ,  $\mathcal{M}$  chooses  $\mathbf{o} \in \{0,1\}^\ell$  and an integer  $C \in \{1, 2, \dots, 2^{m+v}\}$  (this requires choosing  $l + m + v$  bits). Through a call to the  $\#\mathbf{P}$  oracle,  $\mathcal{M}$  computes

$$a = |\{\mathbf{r} \in \{0,1\}^m : \psi(\mathbf{x}, \mathbf{r}) = \mathbf{o}\}|, \quad \text{and} \quad b = |\{\mathbf{r} \in \{0,1\}^m : \psi(\mathbf{x}', \mathbf{r}) = \mathbf{o}\}|.$$

Finally,  $\mathcal{M}$  accepts if  $2^v \cdot a - u \cdot b \geq C$  and otherwise rejects.

**Lemma 2.** *Give two inputs  $\mathbf{x}, \mathbf{x}' \in X^n$ ,  $\mathcal{M}(\psi, \mathbf{x}, \mathbf{x}')$  has exactly  $2^v \cdot 2^m \sum_{\mathbf{o} \in \{0,1\}^\ell} \delta_{\mathbf{x}, \mathbf{x}'}(\mathbf{o})$  accepting executions.*

*Proof.* Let  $\mathbb{1}_{\{X\}}$  be the indicator function, which is one if the predicate  $X$  holds and zero otherwise.

$$\begin{aligned} 2^m 2^v \sum_{\mathbf{o} \in \{0,1\}^\ell} \delta_{\mathbf{x}, \mathbf{x}'}(\mathbf{o}) &= \sum_{\mathbf{o} \in \{0,1\}^\ell} 2^v 2^m \max(\Pr[\psi(\mathbf{x}) = \mathbf{o}] - \alpha \Pr[\psi(\mathbf{x}') = \mathbf{o}], 0) \\ &= \sum_{\mathbf{o} \in \{0,1\}^\ell} 2^v 2^m \max\left(\frac{1}{2^m} \sum_{\mathbf{r} \in \{0,1\}^m} \mathbb{1}_{\{\psi(\mathbf{x}, \mathbf{r}) = \mathbf{o}\}} - \alpha \frac{1}{2^m} \sum_{\mathbf{r} \in \{0,1\}^m} \mathbb{1}_{\{\psi(\mathbf{x}', \mathbf{r}) = \mathbf{o}\}}, 0\right) \\ &= \sum_{\mathbf{o} \in \{0,1\}^\ell} \max\left(2^v \sum_{\mathbf{r} \in \{0,1\}^m} \mathbb{1}_{\{\psi(\mathbf{x}, \mathbf{r}) = \mathbf{o}\}} - 2^v \alpha \sum_{\mathbf{r} \in \{0,1\}^m} \mathbb{1}_{\{\psi(\mathbf{x}', \mathbf{r}) = \mathbf{o}\}}, 0\right) \\ &= \sum_{\mathbf{o} \in \{0,1\}^\ell} \max\left(2^v \sum_{\mathbf{r} \in \{0,1\}^m} \mathbb{1}_{\{\psi(\mathbf{x}, \mathbf{r}) = \mathbf{o}\}} - u \sum_{\mathbf{r} \in \{0,1\}^m} \mathbb{1}_{\{\psi(\mathbf{x}', \mathbf{r}) = \mathbf{o}\}}, 0\right) \\ &= \sum_{\mathbf{o} \in \{0,1\}^\ell} \sum_{C=1}^{2^{v+m}} \mathbb{1}_{\{\max(2^v \sum_{\mathbf{r} \in \{0,1\}^m} \mathbb{1}_{\{\psi(\mathbf{x}, \mathbf{r}) = \mathbf{o}\}} - u \sum_{\mathbf{r} \in \{0,1\}^m} \mathbb{1}_{\{\psi(\mathbf{x}', \mathbf{r}) = \mathbf{o}\}}, 0) \geq C\}} \\ &= \text{number of accepting executions in } \widehat{\mathcal{M}} \end{aligned}$$

□

We can now describe our  $\mathbf{coNP}^{\#\mathbf{P}^{\#\mathbf{P}}}$  procedure for DECIDE- $\varepsilon, \delta$ -DP. The procedure takes as input a probabilistic circuit  $\psi$ .

1. Non-deterministically choose neighboring  $\mathbf{x}$  and  $\mathbf{x}' \in \{0,1\}^n$  (i.e.,  $2n$  bits)
2. Let  $\mathcal{M}$  be the non-deterministic Turing Machine with access to a  $\#\mathbf{P}$ -oracle as described above. Create a machine  $\widehat{\mathcal{M}}$  with no input that executes  $\mathcal{M}$  on  $\psi, \mathbf{x}, \mathbf{x}'$
3. Make an  $\#\mathbf{P}^{\#\mathbf{P}}$  oracle call for the number of accepting executions  $\widehat{\mathcal{M}}$  has.
4. Reject if the number of accepting executions is greater than  $2^v \cdot 2^m \cdot \delta$  and otherwise accept.

By Lemma 2, there is a choice  $\mathbf{x}, \mathbf{x}'$  on which the procedure rejects if and only if  $\psi$  is not  $\varepsilon, \delta$ -differentially private.



## 5 Inapproximability of the privacy parameters $\varepsilon, \delta$

Given the difficulty of deciding if a circuit is differentially private, one might naturally consider whether approximating  $\varepsilon$  or  $\delta$  could be efficient. We show that these tasks are both **NP**-hard and **coNP**-hard.

We show that distinguishing between  $(\varepsilon, \delta)$ , and  $(\varepsilon', \delta')$ -differential privacy is **NP**-hard, by reduction from a problem we call NOT-CONSTANT which we also show is **NP**-hard. A boolean formula is in NOT-CONSTANT if it is satisfiable and not also a tautology.

**Lemma 3.** NOT-CONSTANT is **NP**-hard. (hence CONSTANT is **coNP**-hard).

*Proof.* Clearly, NOT-CONSTANT  $\in$  **NP**, the witness being a pair of satisfying and non-satisfying assignments. We reduce 3-SAT to NOT-CONSTANT. Given a Boolean formula  $\phi$  over variables  $x_1, \dots, x_n$  let  $\phi'(x_1, \dots, x_n, x_{n+1}) = \phi(x_1, \dots, x_n) \wedge x_{n+1}$ . Note that  $\phi'$  is never a tautology as  $\phi'(x_1, \dots, x_n, 0) = 0$ . Furthermore,  $\phi'$  is satisfiable iff  $\phi$  is.  $\square$

In Section 3.1 we used randomized response in the pure differential privacy setting. We now consider the approximate differential privacy variant  $RR_{\varepsilon, \delta} : \{0, 1\} \rightarrow \{\top, \perp\} \times \{0, 1\}$  defined as follows:

$$RR_{\varepsilon, \delta}(x) = \begin{cases} (\top, x) & \text{w.p. } \delta \\ (\perp, x) & \text{w.p. } (1 - \delta) \frac{\alpha}{1 + \alpha} \\ (\perp, \neg x) & \text{w.p. } (1 - \delta) \frac{1}{1 + \alpha} \end{cases} \quad \text{where } \alpha = e^\varepsilon.$$

I.e., with probability  $\delta$ ,  $RR_{\varepsilon, \delta}(x)$  reveals  $x$  and otherwise it executes  $RR_\varepsilon(x)$ . The former is marked with " $\top$ " and the latter with " $\perp$ ". This mechanism is equivalent to the one described in [27].

**Definition 8.** Let  $0 \leq \varepsilon \leq \varepsilon'$ ,  $0 \leq \delta \leq \delta' \leq 1$ , with either  $\varepsilon < \varepsilon'$  or  $\delta < \delta'$ . DISTINGUISH- $(\varepsilon, \delta), (\varepsilon', \delta')$ -DP asks, given a circuit  $\psi$ , guaranteed to be either  $(\varepsilon, \delta)$ -differentially private, or  $(\varepsilon', \delta')$ -differentially private. Determine whether  $\psi$  is  $(\varepsilon, \delta)$ -differentially private or  $(\varepsilon', \delta')$ -differentially private.

**Lemma 4.** DISTINGUISH- $(\varepsilon, \delta), (\varepsilon', \delta')$ -DP is **NP**-hard (and **coNP**-hard).

*Proof.* We reduce NOT-CONSTANT to DISTINGUISH- $(\varepsilon, \delta), (\varepsilon', \delta')$ -DP. Given the boolean formula  $\phi(\mathbf{x})$  on  $n$  bits, we create a probabilistic circuit  $\psi$ . The input to  $\psi$  consists of the  $n$  bits  $\mathbf{x}$  plus a single bit  $y$ . The circuit  $\psi$  has four output bits  $(o_1, o_2, o_3, o_4)$  such that  $(o_1, o_2) = RR_{\varepsilon, \delta}(y)$  and  $(o_3, o_4) = RR_{\varepsilon', \delta'}(\phi(\mathbf{x}))$ .

Observe that  $(o_1, o_2) = RR_{\varepsilon, \delta}(y)$  is always  $(\varepsilon, \delta)$  differentially private. As for  $(o_3, o_4) = RR_{\varepsilon', \delta'}(\phi(\mathbf{x}))$ , if  $\phi \in$  NOT-CONSTANT then there are adjacent  $\mathbf{x}, \mathbf{x}'$  such that  $\phi(\mathbf{x}) \neq \phi(\mathbf{x}')$ . In this case,  $(o_3, o_4) = RR_{\varepsilon', \delta'}(\phi(\mathbf{x}))$  is  $\varepsilon', \delta'$ -differential privacy, and, because  $(\varepsilon, \delta) < (\varepsilon', \delta')$ , so is  $\psi$ . On the other hand, if  $\phi \notin$  NOT-CONSTANT then  $\phi(\mathbf{x})$  does not depend on  $\mathbf{x}$  and hence  $(o_3, o_4)$  does not affect privacy, in which case we get that  $\psi$  is  $(\varepsilon, \delta)$  differentially private.

The same argument also gives **coNP**-hardness.  $\square$

Notice that the above theorem holds when  $\delta = \delta'$  and  $\varepsilon < \varepsilon'$  (similarly,  $\varepsilon = \varepsilon'$  and  $\delta < \delta'$ ), which entails the following theorem:

**Theorem 2.** *Assuming  $\mathbf{P} \neq \mathbf{NP}$ , for any approximation error  $\gamma > 0$ , there does not exist a polynomial time approximation algorithm that given a probabilistic circuit  $\psi$  and  $\delta$  some computes  $\hat{\varepsilon}$ , where  $|\hat{\varepsilon} - \varepsilon| \leq \gamma$  and  $\varepsilon$  is the minimal such that  $\psi$  is  $(\varepsilon, \delta)$ -differentially private within error  $\gamma$ . Similarly, given  $\varepsilon$ , no such  $\hat{\delta}$  can be computed polynomial time where  $|\hat{\delta} - \delta| \leq \gamma$  and  $\delta$  is minimal.*

*Remark 4.* The result also applies when approximating within a given ratio  $\rho > 1$  (e.g. in the case of approximating  $\varepsilon$ , to find  $\hat{\varepsilon}$  such that  $\frac{\hat{\varepsilon}}{\varepsilon} \leq \rho$ ). Moreover, the result also holds when approximating pure differential privacy, that is when  $\delta = 0$ .

## 6 Conclusions and future work

*Verifying differential privacy of probabilistic circuits.* We have shown the difficulty of verifying differential privacy in probabilistic circuits. Deciding  $\varepsilon$ -differential privacy in probabilistic circuits is  $\mathbf{coNP}^{\#\mathbf{P}}$ -complete and  $(\varepsilon, \delta)$ -differential privacy is  $\mathbf{coNP}^{\#\mathbf{P}}$ -hard and in  $\mathbf{coNP}^{\#\mathbf{P}^{\#\mathbf{P}}}$  (a gap that we leave for future work). Both problems are positioned in between the polynomial hierarchy  $\mathbf{PH}$  and  $\mathbf{PSPACE}$ .

Returning to our motivation for this work—developing practical tools for verifying differential privacy—our results seem to point to a deficiency in available tools for model checking. The model checking toolkit includes well established SAT solvers for  $\mathbf{NP}$  (and  $\mathbf{coNP}$ ) problems, solvers for further quantification in  $\mathbf{PH}$ , solvers for  $\#\text{SAT}$  (and hence for  $\#\mathbf{P}$  problems<sup>7</sup>). However to the best of our knowledge, there are currently no solvers that are specialized for mixing the polynomial hierarchy  $\mathbf{PH}$  and counting problems  $\#\mathbf{P}$ , in particular  $\mathbf{coNP}^{\#\mathbf{P}}$  and  $\mathbf{coNP}^{\#\mathbf{P}^{\#\mathbf{P}}}$ .

*Approximating the differential privacy parameters.* We show that distinguishing  $(\varepsilon, \delta)$ -differential privacy from  $(\varepsilon', \delta')$  differential privacy where  $(\varepsilon, \delta) < (\varepsilon', \delta')$  is both  $\mathbf{NP}$ - and  $\mathbf{coNP}$ -hard. We leave refining the classification of this problem as an open problem.

## Acknowledgments

Kobbi Nissim and Marco Gaboardi were supported by NSF grant No. 1565387 TWC: Large: Collaborative: Computing Over Distributed Sensitive Data. David Purser was supported by the UK EPSRC Centre for Doctoral Training in Urban Science (EP/L016400/1). Research partially done while M.G. and K.N. participated in the “Data Privacy: Foundations and Applications” program held at the Simons Institute, UC Berkeley in spring 2019.

## References

1. Abowd, J.M.: The us census bureau adopts differential privacy. In: Proceedings of the 24th ACM SIGKDD International Conference on Knowledge Discovery & Data Mining. pp. 2867–2867. ACM (2018)
2. Albarghouthi, A., Hsu, J.: Synthesizing coupling proofs of differential privacy. Proceedings of the ACM on Programming Languages **2**(POPL), 58 (2017)
3. Alvim, M.S., Andrés, M.E., Chatzikokolakis, K., Palamidessi, C.: On the relation between differential privacy and quantitative information flow. In: International Colloquium on Automata, Languages, and Programming. pp. 60–76. Springer (2011)
4. Apple: Apple differential privacy technical overview. Online at: [https://www.apple.com/privacy/docs/Differential\\_Privacy\\_Overview.pdf](https://www.apple.com/privacy/docs/Differential_Privacy_Overview.pdf)

<sup>7</sup> See, for example, <http://beyonddnp.org/pages/solvers/>, for a range of solvers

5. Barthe, G., Gaboardi, M., Gallego Arias, E.J., Hsu, J., Roth, A., Strub, P.Y.: Higher-order approximate relational refinement types for mechanism design and differential privacy. In: POPL. pp. 55–68 (2015). <https://doi.org/10.1145/2676726.2677000>
6. Barthe, G., Gaboardi, M., Grégoire, B., Hsu, J., Strub, P.Y.: Proving differential privacy via probabilistic couplings. In: 2016 31st Annual ACM/IEEE Symposium on Logic in Computer Science (LICS). pp. 1–10. IEEE (2016)
7. Barthe, G., Gaboardi, M., Hsu, J., Pierce, B.: Programming language techniques for differential privacy. *ACM SIGLOG News* **3**(1), 34–53 (2016)
8. Barthe, G., Köpf, B., Olmedo, F., Zanella Beguelin, S.: Probabilistic relational reasoning for differential privacy. *ACM SIGPLAN Notices* **47**(1), 97–110 (2012)
9. Bichsel, B., Gehr, T., Drachler-Cohen, D., Tsankov, P., Vechev, M.T.: Dp-finder: Finding differential privacy violations by sampling and optimization. In: Proceedings of the 2018 ACM SIGSAC Conference on Computer and Communications Security, CCS 2018, Toronto, ON, Canada, October 15–19, 2018. pp. 508–524 (2018). <https://doi.org/10.1145/3243734.3243863>, <https://doi.org/10.1145/3243734.3243863>
10. Chadha, R., Kini, D., Viswanathan, M.: Quantitative information flow in boolean programs. In: International Conference on Principles of Security and Trust. pp. 103–119. Springer (2014)
11. Chatzikokolakis, K., Gebler, D., Palamidessi, C., Xu, L.: Generalized bisimulation metrics. In: CONCUR. pp. 32–46. Springer (2014)
12. Chistikov, D., Dimitrova, R., Majumdar, R.: Approximate counting in smt and value estimation for probabilistic programs. *Acta Informatica* **54**(8), 729–764 (2017)
13. Chistikov, D., Murawski, A.S., Purser, D.: Bisimilarity distances for approximate differential privacy. In: International Symposium on Automated Technology for Verification and Analysis. pp. 194–210. Springer (2018)
14. Chistikov, D., Murawski, A.S., Purser, D.: Asymmetric distances for approximate differential privacy. In: 30th International Conference on Concurrency Theory (CONCUR 2019). Schloss Dagstuhl-Leibniz-Zentrum fuer Informatik (2019)
15. D’Antoni, L., Gaboardi, M., Gallego Arias, E.J., Haeberlen, A., Pierce, B.: Sensitivity analysis using type-based constraints. In: Proceedings of the 1st annual workshop on Functional programming concepts in domain-specific languages. pp. 43–50. ACM (2013)
16. Differential Privacy Team, Apple: Learning with privacy at scale. Online at: <https://machinelearning.apple.com/docs/learning-with-privacy-at-scale/appledifferentialprivacysystem.pdf> (2017)
17. Ding, Z., Wang, Y., Wang, G., Zhang, D., Kifer, D.: Detecting violations of differential privacy. In: Proceedings of the 2018 ACM SIGSAC Conference on Computer and Communications Security, CCS 2018, Toronto, ON, Canada, October 15–19, 2018. pp. 475–489 (2018). <https://doi.org/10.1145/3243734.3243818>, <https://doi.org/10.1145/3243734.3243818>
18. Dwork, C., Kenthapadi, K., McSherry, F., Mironov, I., Naor, M.: Our data, ourselves: Privacy via distributed noise generation. In: Annual International Conference on the Theory and Applications of Cryptographic Techniques. pp. 486–503. Springer (2006)
19. Dwork, C., McSherry, F., Nissim, K., Smith, A.: Calibrating noise to sensitivity in private data analysis. In: Theory of cryptography conference. pp. 265–284. Springer (2006)
20. Dwork, C., Rothblum, G.N., Vadhan, S.P.: Boosting and differential privacy. In: 51th Annual IEEE Symposium on Foundations of Computer Science, FOCS 2010, October 23–26, 2010, Las Vegas, Nevada, USA. pp. 51–60 (2010). <https://doi.org/10.1109/FOCS.2010.12>, <https://doi.org/10.1109/FOCS.2010.12>
21. Erlingsson, Ú., Pihur, V., Korolova, A.: Rappor: Randomized aggregatable privacy-preserving ordinal response. In: Proceedings of the 2014 ACM SIGSAC conference on computer and communications security. pp. 1054–1067. ACM (2014)
22. Fredrikson, M., Jha, S.: Satisfiability modulo counting: A new approach for analyzing privacy properties. In: Proceedings of the Joint Meeting of the Twenty-Third EACSL Annual Conference on Computer Science Logic (CSL) and the Twenty-Ninth Annual ACM/IEEE Symposium on Logic in Computer Science (LICS). p. 42. ACM (2014)
23. Littman, M.L., Goldsmith, J., Mundhenk, M.: The computational complexity of probabilistic planning. *Journal of Artificial Intelligence Research* **9**, 1–36 (1998)
24. Lyu, M., Su, D., Li, N.: Understanding the sparse vector technique for differential privacy. *PVLDB* **10**(6), 637–648 (2017). <https://doi.org/10.14778/3055330.3055331>, <http://www.vldb.org/pvldb/vol10/p637-lyu.pdf>
25. McSherry, F.D.: Privacy integrated queries: an extensible platform for privacy-preserving data analysis. In: Proceedings of the 2009 ACM SIGMOD International Conference on Management of data. pp. 19–30. ACM (2009)

26. Mironov, I.: On significance of the least significant bits for differential privacy. In: CCS. ACM (2012)
27. Murtagh, J., Vadhan, S.: The complexity of computing the optimal composition of differential privacy. In: Theory of Cryptography Conference. pp. 157–175. Springer (2016)
28. Papernot, N., Abadi, M., Erlingsson, U., Goodfellow, I., Talwar, K.: Semi-supervised knowledge transfer for deep learning from private training data. arXiv preprint arXiv:1610.05755 (2016)
29. Reed, J., Pierce, B.C.: Distance makes the types grow stronger: a calculus for differential privacy. In: ACM Sigplan Notices. vol. 45, pp. 157–168. ACM (2010)
30. Roy, I., Setty, S.T., Kilzer, A., Shmatikov, V., Witchel, E.: Airavat: Security and privacy for mapreduce. In: NSDI. vol. 10, pp. 297–312 (2010)
31. Toda, S.: PP is as hard as the polynomial-time hierarchy. SIAM Journal on Computing **20**(5), 865–877 (1991)
32. Tschantz, M.C., Kaynar, D., Datta, A.: Formal verification of differential privacy for interactive systems. ENTCS **276**, 61–79 (2011)
33. Warner, S.L.: Randomized response: A survey technique for eliminating evasive answer bias. Journal of the American Statistical Association **60**(309), 63–69 (1965)
34. Yasuoka, H., Terauchi, T.: On bounding problems of quantitative information flow. In: European Symposium on Research in Computer Security. pp. 357–372. Springer (2010)
35. Yasuoka, H., Terauchi, T.: Quantitative information flow-verification hardness and possibilities. In: 2010 23rd IEEE Computer Security Foundations Symposium. pp. 15–27. IEEE (2010)
36. Zhang, D., Kifer, D.: Lightdp: towards automating differential privacy proofs. In: ACM SIGPLAN Notices. vol. 52, pp. 888–901. ACM (2017)

## A Hardness of DECIDE- $\epsilon$ -DP by number of input/output bits

**Lemma 5.** *Given a circuit  $\psi$ , we show the the following hardness results for large and small number of input and output bits:*

# Input Bits	# Output Bits	Hardness
$\Omega(n)$	1	<b>coNP<sup>#P</sup>-hard</b>
1	$\Omega(n)$	<b>coNP<sup>#P</sup>-hard</b>
1	1	<b>PP-hard</b>

*Remark 5.* Note that the hardness results entail hardness for any larger number of input and output bits; for example  $\Theta(\log n)$ -input,  $\Theta(\log n)$ -output is **PP-hard** and  $\Theta(n)$ -input,  $\Theta(n)$ -output is **coNP<sup>#P</sup>-hard**.

*Proof (Proof for large input small output.).* Given  $\phi(\mathbf{x}, \mathbf{y})$ , we reduce  $\phi \in \text{ALL-MIN-SAT}$  to DECIDE- $\epsilon$ -DP. Our resulting circuit  $\psi$  will have 1 output bit but  $n + 1$  input bits

Let  $\psi(\mathbf{x}, z) = (z \vee p_1) \wedge (\neg z \vee (p_2 \vee (p_3 \wedge p_4 \wedge \phi(\mathbf{x}, \mathbf{r}))))$ , with  $p_1, \dots, p_4, \mathbf{r}$  determined randomly. This circuit has the property:

- If  $z = 0$  return 1 w.p.  $\frac{1}{2}$ .
- If  $z = 1$  return 1 w.p.  $\frac{1}{2} + \frac{1}{4} \Pr[\phi(\mathbf{x}) = 1]$

*Claim.*  $\phi \in \text{ALL-MIN-SAT} \iff \ln(\frac{4}{3})$ -differential privacy holds.

If  $\phi \notin \text{ALL-MIN-SAT}$  then for some  $\mathbf{x}$  with  $\Pr[\phi(\mathbf{x}) = 1] > \frac{1}{2}$ ,  $\Pr[\phi(\mathbf{x}) = 0] < \frac{1}{2}$

$$\begin{aligned}
 \frac{\Pr[\psi(\mathbf{x}, 0) = 0]}{\Pr[\psi(\mathbf{x}, 1) = 0]} &= \frac{\frac{1}{2}}{1 - \frac{1}{2} - \frac{1}{4} \Pr[\phi(\mathbf{x}) = 1]} = \frac{\frac{1}{2}}{\frac{1}{4} + \frac{1}{4} - \frac{1}{4} \Pr[\phi(\mathbf{x}) = 1]} = \frac{\frac{1}{2}}{\frac{1}{4} + \frac{1}{4}(1 - \Pr[\phi(\mathbf{x}) = 1])} \\
 &= \frac{\frac{1}{2}}{\frac{1}{4} + \frac{1}{4}(1 - \Pr[\phi(\mathbf{x}) = 1])} = \frac{\frac{1}{2}}{\frac{1}{4} + \frac{1}{4}(\Pr[\phi(\mathbf{x}) = 0])} > \frac{\frac{1}{2}}{\frac{1}{4} + \frac{1}{4} \cdot \frac{1}{2}} = \frac{4}{3} \approx 1.3
 \end{aligned}$$

If  $\phi \in \text{ALL-MIN-SAT}$  then for all  $\mathbf{x}$  we have  $\Pr[\phi(\mathbf{x}) = 1] \leq \frac{1}{2}$ ,  $\Pr[\phi(\mathbf{x}) = 0] \geq \frac{1}{2}$

$$\begin{aligned} \frac{\Pr[\psi(\mathbf{x}, 0) = 0]}{\Pr[\psi(\mathbf{x}, 1) = 0]} &\leq \frac{4}{3} \approx 1.3 \\ \frac{\Pr[\psi(\mathbf{x}, 1) = 0]}{\Pr[\psi(\mathbf{x}, 0) = 0]} &= \frac{1 - \frac{1}{2} - \frac{1}{4} \Pr[\phi(\mathbf{x}) = 1]}{\frac{1}{2}} = \frac{\frac{1}{4} + \frac{1}{4} \Pr[\phi(\mathbf{x}) = 0]}{\frac{1}{2}} \leq 1 \\ \frac{\Pr[\psi(\mathbf{x}, 1) = 1]}{\Pr[\psi(\mathbf{x}, 0) = 1]} &= \frac{\frac{1}{2} + \frac{1}{4} \Pr[\phi(\mathbf{x}) = 1]}{\frac{1}{2}} \leq \frac{\frac{1}{2} + \frac{1}{4} \cdot \frac{1}{2}}{\frac{1}{2}} = 1.25 \\ \frac{\Pr[\psi(\mathbf{x}, 0) = 1]}{\Pr[\psi(\mathbf{x}, 1) = 1]} &= \frac{\frac{1}{2}}{\frac{1}{2} + \frac{1}{4} \Pr[\phi(\mathbf{x}) = 1]} \leq 1 \\ \frac{\Pr[\psi(\mathbf{x}, 0) = 1]}{\Pr[\psi(\mathbf{x}', 0) = 1]} &= \frac{\frac{1}{2}}{\frac{1}{2}} = 1 \\ \frac{\Pr[\psi(\mathbf{x}, 1) = 1]}{\Pr[\psi(\mathbf{x}', 1) = 1]} &= \frac{\frac{1}{2} + \frac{1}{4} \Pr[\phi(\mathbf{x}) = 1]}{\frac{1}{2} + \frac{1}{4} \Pr[\phi(\mathbf{x}') = 1]} \leq \frac{\frac{1}{2} + \frac{1}{4} \cdot \frac{1}{2}}{\frac{1}{2} + \frac{1}{4} \cdot 0} = 1.25 \\ \frac{\Pr[\psi(\mathbf{x}, 1) = 0]}{\Pr[\psi(\mathbf{x}', 1) = 0]} &= \frac{1 - \frac{1}{2} - \frac{1}{4} \Pr[\phi(\mathbf{x}) = 1]}{1 - \frac{1}{2} - \frac{1}{4} \Pr[\phi(\mathbf{x}') = 1]} \leq \frac{\frac{1}{2} + \frac{1}{4} \cdot 0}{1 - \frac{1}{2} - \frac{1}{4} \cdot \frac{1}{2}} = \frac{4}{3} \end{aligned}$$

□

*Proof (Proof for small input large output.).* Given  $\phi(\mathbf{x}, \mathbf{y})$ , we reduce  $\phi \in \text{ALL-MIN-SAT}$  to  $\text{DECIDE-}\varepsilon\text{-DP}$ . Our resulting circuit  $\psi$  will have 1 input bit but  $n + 1$  output bits.

Let  $\psi(z) = (\mathbf{x}, (z \vee p_1) \wedge (\neg z \vee (p_2 \vee (p_3 \wedge p_4 \wedge \phi(\mathbf{x}, \mathbf{r}))))$ , with  $p_1, \dots, p_4, \mathbf{x}, \mathbf{r}$  all chosen randomly. Then the circuit has the property:

- Choose and output some  $\mathbf{x}$  and,
- If  $z = 0$  return 1 w.p.  $\frac{1}{2}$ .
- If  $z = 1$  return 1 w.p.  $\frac{1}{2} + \frac{1}{4} \Pr[\phi(\mathbf{x}) = 1]$

*Claim.*  $\phi \in \text{ALL-MIN-SAT} \iff \ln(\frac{4}{3})$ -differential privacy holds.

If  $\phi \notin \text{ALL-MIN-SAT}$  then for some  $\mathbf{x}$  with  $\Pr[\phi(\mathbf{x}) = 1] > \frac{1}{2}$ ,  $\Pr[\phi(\mathbf{x}) = 0] < \frac{1}{2}$

$$\begin{aligned} \frac{\Pr[\psi(0) = (\mathbf{x}, 0)]}{\Pr[\psi(1) = (\mathbf{x}, 0)]} &= \frac{\frac{1}{2}}{1 - \frac{1}{2} - \frac{1}{4} \Pr[\phi(\mathbf{x}) = 1]} = \frac{\frac{1}{2}}{\frac{1}{4} + \frac{1}{4} - \frac{1}{4} \Pr[\phi(\mathbf{x}) = 1]} = \frac{\frac{1}{2}}{\frac{1}{4} + \frac{1}{4}(1 - \Pr[\phi(\mathbf{x}) = 1])} \\ &= \frac{\frac{1}{2}}{\frac{1}{4} + \frac{1}{4}(1 - \Pr[\phi(\mathbf{x}) = 1])} = \frac{\frac{1}{2}}{\frac{1}{4} + \frac{1}{4}(\Pr[\phi(\mathbf{x}) = 0])} > \frac{\frac{1}{2}}{\frac{1}{4} + \frac{1}{4} \cdot \frac{1}{2}} = \frac{4}{3} \approx 1.3 \end{aligned}$$

If  $\phi \in \text{ALL-MIN-SAT}$  then for all  $\mathbf{x}$  we have  $\Pr[\phi(\mathbf{x}) = 1] \leq \frac{1}{2}$ ,  $\Pr[\phi(\mathbf{x}) = 0] \geq \frac{1}{2}$

$$\begin{aligned} \frac{\Pr[\psi(0) = (\mathbf{x}, 0)]}{\Pr[\psi(1) = (\mathbf{x}, 0)]} &\leq \frac{4}{3} \approx 1.3 \\ \frac{\Pr[\psi(1) = (\mathbf{x}, 0)]}{\Pr[\psi(0) = (\mathbf{x}, 0)]} &= \frac{1 - \frac{1}{2} - \frac{1}{4} \Pr[\phi(\mathbf{x}) = 1]}{\frac{1}{2}} = \frac{\frac{1}{4} + \frac{1}{4} \Pr[\phi(\mathbf{x}) = 0]}{\frac{1}{2}} \leq 1 \\ \frac{\Pr[\psi(1) = (\mathbf{x}, 1)]}{\Pr[\psi(0) = (\mathbf{x}, 1)]} &= \frac{\frac{1}{2} + \frac{1}{4} \Pr[\phi(\mathbf{x}) = 1]}{\frac{1}{2}} \leq \frac{\frac{1}{2} + \frac{1}{4} \cdot \frac{1}{2}}{\frac{1}{2}} = 1.25 \\ \frac{\Pr[\psi(0) = (\mathbf{x}, 1)]}{\Pr[\psi(1) = (\mathbf{x}, 1)]} &= \frac{\frac{1}{2}}{\frac{1}{2} + \frac{1}{4} \Pr[\phi(\mathbf{x}) = 1]} \leq 1 \end{aligned}$$

□

*Proof (Proof for small input small output).* Given  $\phi(\mathbf{x})$ , we reduce  $\phi \in \text{MAJ-SAT}$  to  $\text{DECIDE-}\varepsilon\text{-DP}$ . Our resulting circuit  $\psi$  will have 1 output bit and 1 input bits

Let  $\psi(z) = (p_1 \wedge z) \vee (\neg p_1 \wedge (z \oplus \phi(\mathbf{r})))$ , where  $p_1$  and  $\mathbf{r}$  are chosen randomly. Then the circuit has the property:

- probability  $\frac{1}{2}$  output  $z$ .
- probability  $\frac{1}{2}$  output  $z \oplus \phi(\mathbf{r})$ . (Output  $z$ , flipped proportionally to the number of accepting allocations to  $\phi$ .)

*Claim.*  $\phi \in \text{MAJ-SAT} \iff \psi$  is  $\ln(3)$ -differentially private

The probabilities behave as follows, where each case is also bound by  $\frac{1}{2}$  in the direction consistent with the probability shown.

Output ↓	Input →	1	0	Max-Ratio
0	MAJ	$> \frac{1}{4}$	$< \frac{3}{4}$	$> 3$
	MIN	$\leq \frac{1}{4}$	$\geq \frac{3}{4}$	$\leq 3$
1	MAJ	$< \frac{3}{4}$	$> \frac{1}{4}$	$> 3$
	MIN	$\geq \frac{3}{4}$	$\leq \frac{1}{4}$	$\leq 3$

Then in the either MAJ case we have the ratio is greater than 3 (violating privacy) and for both MIN case the ratio is bounded by 3 (satisfying privacy).  $\square$

## B Direct Proof that $\text{DECIDE-}\varepsilon, \delta\text{-DP}$ is $\text{coNP}^{\#\text{P}}$ -hard

We prove that  $\text{DECIDE-}\varepsilon, \delta\text{-DP}$  is  $\text{coNP}^{\#\text{P}}$ -hard, even when there is just one output bit and for every  $\varepsilon$ .

**Theorem 3.**  $\text{DECIDE-}\varepsilon, \delta\text{-DP}$  is  $\text{coNP}^{\#\text{P}}$ -hard.

We could show  $\text{DECIDE-}\varepsilon, \delta\text{-DP}$  by reduction from  $\text{ALL-MIN-SAT}$ , which would entail that  $(\varepsilon, \frac{1}{2})$ -differential privacy is  $\text{coNP}^{\#\text{P}}$ -hard. To show hardness for a large range of  $\delta$  we first generalise  $\text{ALL-MIN-SAT}$  to  $\text{ALL-FRAC-}f\text{-SAT}$ , showing this is also hard. We will then reduce  $\text{ALL-FRAC-}f\text{-SAT}$  to  $\text{ALL-MIN-SAT}$ .

### B.1 Generalising $\text{ALL-MIN-SAT}$

Let us first generalise  $\text{ALL-MIN-SAT}$  to  $\text{ALL-FRAC-}f\text{-SAT}$ , which rather than requiring that the minority (half) of allocations to  $y$  give true, rather no more than a fraction  $f$ . Similarly we generalise  $\text{E-MAJ-SAT}$  to  $\text{E-FRAC-}f\text{-SAT}$ .

**Definition 9.** A formula  $\phi(\mathbf{x}, \mathbf{y})$ ,  $\mathbf{x} \in \{0, 1\}^n$ ,  $\mathbf{y} \in \{0, 1\}^m$  and  $f \in [0, 1] \cap \mathbb{Q}$  is  $\text{ALL-FRAC-}f\text{-SAT}$  if for every  $\mathbf{x} \in \{0, 1\}^n$

$$\frac{|\{\mathbf{y} \in \{0, 1\}^m \mid \phi(\mathbf{x}, \mathbf{y}) \text{ is true}\}|}{2^m} \leq f$$

*Remark 6.* For  $f = 0$ , we require that for all  $\mathbf{x}$ , no input of  $\mathbf{y}$  gives true, therefore we require  $\phi$  is unsatisfiable. For  $f = 1$ , we have essentially no restriction and for  $f = \frac{2^m-1}{2^m}$  we require that  $\phi$  is not a tautology.  $\text{ALL-MIN-SAT}$  is then when  $f = \frac{1}{2}$ .

**Definition 10.** A formula  $\phi$  is  $\text{E-FRAC-}f\text{-SAT}$  if it is not  $\text{ALL-FRAC-}f\text{-SAT}$ .

This means a formula  $\phi(\mathbf{x}, \mathbf{y})$ ,  $\mathbf{x} \in \{0, 1\}^n$ ,  $\mathbf{y} \in \{0, 1\}^m$  and  $f \in [0, 1] \cap \mathbb{Q}$  is E-FRAC- $f$ -SAT if there exists an allocation  $\mathbf{x}$  that more than  $f$  fraction of allocations to  $\mathbf{y}$  result in  $\phi(\mathbf{x}, \mathbf{y})$  being true. That is there exists  $\mathbf{x} \in \{0, 1\}^n$  such that  $\frac{|\{\mathbf{y} \in \{0, 1\}^m \mid \phi(\mathbf{x}, \mathbf{y}) \text{ is true}\}|}{2^m} > f$ .

Towards showing ALL-FRAC- $f$ -SAT is  $\mathbf{coNP}^{\#\mathbf{P}}$ -hard, we show E-FRAC- $f$ -SAT is  $\mathbf{NP}^{\#\mathbf{P}}$ -hard, entailing Corollary 1.

**Lemma 6.** E-FRAC- $f$ -SAT is  $\mathbf{NP}^{\#\mathbf{P}}$ -hard for  $f \in [\frac{1}{2^m}, \frac{2^m-1}{2^m}]$ .

**Corollary 1.** ALL-FRAC- $f$ -SAT is  $\mathbf{coNP}^{\#\mathbf{P}}$ -hard for  $f \in [\frac{1}{2^m}, \frac{2^m-1}{2^m}]$ .

*Proof (Proof of Lemma 6).* **Proof for  $f = \frac{1}{2^{k+1}}$**

We reduce E-MAJ-SAT, given a formula  $\phi(\mathbf{x}, \mathbf{y})$  to E-FRAC- $\frac{1}{2^{k+1}}$ -SAT.

(We assume  $\frac{1}{2^{k+1}}$  takes  $O(k)$  bits.)

Define a formula  $\phi'(\mathbf{x}, \mathbf{w})$ , with  $\mathbf{w} \in \{0, 1\}^{m+k}$ . Let  $\mathbf{w} = (y_1, \dots, y_m, z_1 \dots z_k)$ , where  $\mathbf{y} = (y_1, \dots, y_m)$ .

$\phi'(\mathbf{x}, \mathbf{w}) = z_1 \wedge \dots \wedge z_k \wedge \phi(\mathbf{x}, y_1, \dots, y_m)$

For  $\mathbf{x}$  fixed if  $g$  allocations to  $y_1, \dots, y_m$  satisfy  $\phi$  then each of these satisfy  $\phi'$  only when  $z_1 = \dots = z_k = 1$ . All remaining times are unsatisfied.

Suppose  $\frac{g}{2^m}$  of  $\mathbf{y}$ 's satisfy  $\phi(\mathbf{x}, \mathbf{y})$  then  $\frac{g}{2^m \cdot 2^k}$   $\mathbf{w}$ 's satisfy  $\phi'(\mathbf{x}, \mathbf{w})$ .

That is we have:

$$\frac{g}{2^m \cdot 2^k} > \frac{1}{2^{k+1}} \iff \frac{g}{2^m} > \frac{1}{2}.$$

**Proof for  $f = \frac{a}{2^{k+1}}$**  We reduce E-MAJ-SAT, given a formula  $\phi(\mathbf{x}, \mathbf{y})$  to E-FRAC- $\frac{1}{2^{k+1}}$ -SAT. Assume  $a$  odd (otherwise, half and take  $\frac{a/2}{2^k}$ ) and greater than 1 (otherwise use above).

Define a formula  $\phi'(\mathbf{x}, \mathbf{w})$ , with  $\mathbf{w} \in \{0, 1\}^{m+k}$ . Let  $\mathbf{w} = (y_1, \dots, y_m, z_1 \dots z_k)$ , where  $\mathbf{y} = (y_1, \dots, y_m)$ . Let  $b = \frac{a-1}{2}$  ( $b$  is always between 1 and  $2^k - 1$ ).

Let  $\chi_{\frac{b}{2^k}}(z_1, \dots, z_k)$  be a circuit on  $k$  bits, which is true for  $\frac{b}{2^k}$  of its inputs of  $z_1 \dots z_k$ , but not true for  $z_1 = \dots = z_k = 1$  when  $b < 2^k$ .<sup>8</sup>

Then we let  $\phi'(\mathbf{x}, \mathbf{w}) = (z_1 \wedge \dots \wedge z_k \wedge \phi(\mathbf{x}, y_1, \dots, y_m)) \vee \chi_{\frac{b}{2^k}}(z_1, \dots, z_k)$ .

That is the formula  $\phi'$  is true whenever  $z_1 = \dots = z_k = 1$  and  $\phi$  is true, or on the  $\frac{b}{2^k}$  choices of  $z_1 \dots z_k$ .

Suppose  $\frac{g}{2^m}$  of  $\mathbf{y}$ 's satisfy  $\phi(\mathbf{x}, \mathbf{y})$  then  $\frac{g}{2^m \cdot 2^k} + \frac{b}{2^k} = \frac{g}{2^m \cdot 2^k} + \frac{a-1}{2^{k+1}}$   $\mathbf{w}$ 's satisfy  $\phi'(\mathbf{x}, \mathbf{w})$ .

That is we have:

$$\frac{g}{2^m \cdot 2^k} + \frac{a-1}{2^{k+1}} > \frac{a}{2^{k+1}} \iff \frac{g}{2^m \cdot 2^k} > \frac{1}{2^{k+1}} \iff \frac{g}{2^m} > \frac{1}{2}$$

**Proof for  $f = \frac{a}{b}$**

Let  $m$  be the number such that  $\mathbf{y} \in \{0, 1\}^m$ , the number of  $\mathbf{y}$  bits of the formula, or the number of 'MAJ' bits. Let  $z$  be such that  $\frac{z}{2^m} < \frac{a}{b} < \frac{z+1}{2^m}$ . We reduce E-FRAC- $\frac{z}{2^m}$ -SAT to E-FRAC- $\frac{a}{b}$ -SAT, by simply taking  $\phi$  unchanged.

Suppose  $\frac{g}{2^m}$  of  $\mathbf{y}$ 's satisfy  $\phi(\mathbf{x}, \mathbf{y})$  then

$$\frac{g}{2^m} > \frac{z}{2^m} \iff \frac{g}{2^m} \geq \frac{z+1}{2^m} \iff \frac{g}{2^m} > \frac{a}{b}.$$

<sup>8</sup> Given  $b, k$  such that  $0 < \frac{b}{2^k} < 1$ , we create a formula, over  $2k$  bits, which given two  $k$ -bit integers  $m, n$ , return whether  $m \leq n$  (such a formula is of size polynomial in  $k$ ). By fixing  $n$  to  $b$ , we have a circuit on  $m$  input bits which decides if  $m \leq b$ . Instead sample over the  $m$  bits of  $m$  producing a circuit  $\chi_{\frac{b}{2^k}}$  which is true on  $\frac{b}{2^k}$  of its inputs.

## B.2 Main Proof of Theorem 3

*Proof.* Assume we are given an instance of ALL-FRAC- $f$ -SAT, a formula  $\phi(\mathbf{x}, \mathbf{y})$  for  $\mathbf{x} \in \{0, 1\}^n$ ,  $\mathbf{y} \in \{0, 1\}^m$  and  $f \in [0, 1]$ .

We define a circuit  $\psi$ , with inputs  $\mathbf{x} \in \{0, 1\}^{n+1}$ , we write as  $(z, \mathbf{x}_1, \dots, \mathbf{x}_n)$ ; matching the inputs  $\mathbf{x}$  and an additional bit  $z$ . There are  $m$  probabilistic bits  $\mathbf{r} \in \{0, 1\}^m$ , matching  $\mathbf{y}$ . There is one output bit  $\mathbf{o} \in \{0, 1\}^1$ . The circuit  $\psi$  will behave like  $\phi$  when  $z = 1$  and simply output 0 when  $z = 0$ ; i.e.  $\mathbf{o}_1 = z \wedge \phi(\mathbf{x}_1, \dots, \mathbf{x}_n, \mathbf{r}_1, \dots, \mathbf{r}_m)$ .

*Claim.*  $\phi \in \text{ALL-FRAC-}f\text{-SAT}$  if and only if  $\psi$  is  $\varepsilon, \delta$ -differentially private, for  $\delta = f$  and any choice of  $\varepsilon$  (including zero).

*Direction: if  $\phi \notin \text{ALL-FRAC-}f\text{-SAT}$  then not  $(\varepsilon, \delta)$ -differentially private.* Given  $\phi \notin \text{ALL-MIN-SAT}$  then there exists  $\mathbf{x} \in \{0, 1\}^n$  such that  $\phi(\mathbf{x}, \mathbf{y})$  is on more than  $f$  portion of  $\mathbf{y} \in \{0, 1\}^m$ . We show the differential privacy condition is violated exactly using this  $\mathbf{x}$ , let  $\mathbf{x} = (1, \mathbf{x}_1, \dots, \mathbf{x}_n)$  and  $\mathbf{x}' = (0, \mathbf{x}_1, \dots, \mathbf{x}_n)$ . Let us consider the probability of the event  $\mathbf{o}_1 = 1$ .

Then we have  $\Pr[\psi(1, \mathbf{x}_1, \dots, \mathbf{x}_n) = 1] > f$  and  $\Pr[\psi(0, \mathbf{x}_1, \dots, \mathbf{x}_n) = 1] = 0$ . Violating differential privacy since,

$$\Pr[\psi(1, \mathbf{x}_1, \dots, \mathbf{x}_n) = 1] - e^\varepsilon \Pr[\psi(0, \mathbf{x}_1, \dots, \mathbf{x}_n) = 1] > f - 0 = \delta.$$

*Direction: if  $\phi \in \text{ALL-FRAC-}f\text{-SAT}$  then  $(\varepsilon, \delta)$ -differentially private.* Since  $\phi \in \text{ALL-FRAC-}f\text{-SAT}$  then for all  $\mathbf{x} \in \{0, 1\}^n$  we have  $\phi(\mathbf{x}, \mathbf{y})$  true for less or equal  $f$  proportion of the allocations to  $\mathbf{y} \in \{0, 1\}^m$ . Equivalently the more than  $f$  of  $\mathbf{y} \in \{0, 1\}^m$  with  $\phi(\mathbf{x}, \mathbf{y})$  false.

To show privacy we consider all adjacent inputs and all output event. The output events are  $E \subseteq \{0, 1\}^1$ , giving  $\{\}, \{0\}, \{1\}, \{0, 1\}$ . The probability of ‘no output’  $\{\}$  is zero for all inputs, so cannot violate differential privacy. The probability of ‘output anything’  $\{0, 1\}$  is one for all inputs, so does not violate differential privacy. Thus we argue that events  $\{0\}$  and  $\{1\}$  do not violate differential privacy, for all adjacent inputs.

Inputs take the form  $\mathbf{x} = (z, \mathbf{x}_1, \dots, \mathbf{x}_n)$ , and  $\mathbf{x}, \mathbf{x}'$  can be adjacent either with fixed  $\mathbf{x}$  and differing  $z$  or, fixed  $z$  and  $\mathbf{x}$  differing in one position; in each case we show  $\Pr[\psi(\mathbf{x}) = E] - e^\varepsilon \Pr[\psi(\mathbf{x}') = E] \leq \delta$  and  $\Pr[\psi(\mathbf{x}') = E] - e^\varepsilon \Pr[\psi(\mathbf{x}) = E] \leq \delta$

*Let  $z$  be fixed to zero.* Hence we have  $\mathbf{x}, \mathbf{x}'$  with  $\mathbf{x}$ 's differing in one position. For  $z = 0$  the circuit outputs zero in all cases, independently of  $\mathbf{x}$ , thus does not violate differential privacy since  $\Pr[\psi(\mathbf{x}) = E] = \Pr[\psi(\mathbf{x}') = E]$ .

*Let  $z$  be fixed to one.* Hence we have  $\mathbf{x}, \mathbf{x}'$  with  $\mathbf{x}$ 's differing in one position. Without loss of generality suppose the difference is  $x_j$ .

For the event  $E = \{1\}$  we have the probability being  $\leq f$  for each input; that is regardless of  $\mathbf{x}$  we have  $\Pr[\psi(\mathbf{x}) = 1] \leq f$ . So  $\Pr[\psi(\mathbf{x}) = E] - e^\varepsilon \Pr[\psi(\mathbf{x}') = E] \leq \Pr[\psi(\mathbf{x}) = E] \leq f = \delta$  and  $\Pr[\psi(\mathbf{x}') = E] - e^\varepsilon \Pr[\psi(\mathbf{x}) = E] \leq \Pr[\psi(\mathbf{x}') = E] \leq f = \delta$ .

For the event  $E = \{0\}$  we have the probability being  $\geq 1 - f$  for each input; that is regardless of  $\mathbf{x}$  we have  $\Pr[\psi(\mathbf{x}) = 0] \geq 1 - f$ . So  $\Pr[\psi(\mathbf{x}) = E] - e^\varepsilon \Pr[\psi(\mathbf{x}') = E] \leq 1 - \Pr[\psi(\mathbf{x}') = E] \leq f = \delta$  and  $\Pr[\psi(\mathbf{x}') = E] - e^\varepsilon \Pr[\psi(\mathbf{x}) = E] \leq 1 - \Pr[\psi(\mathbf{x}) = E] \leq f = \delta$ .

*Let  $\mathbf{x}$  be fixed.* Hence we have  $\mathbf{x}, \mathbf{x}'$  with differing  $z$ . Without loss of generality, let  $\mathbf{x}$  have  $z = 1$ , that is  $\mathbf{x} = (1, \mathbf{x}_1, \dots, \mathbf{x}_n)$  and  $\mathbf{x}'$  have  $z = 0$ ,  $\mathbf{x}' = (0, \mathbf{x}_1, \dots, \mathbf{x}_n)$ .

For the event  $\{1\}$ , when  $z = 1$ , we have  $\Pr[\psi(\mathbf{x}) = 1] \leq f$ , but for  $z = 0$  the circuit is always 0, thus  $\Pr[\psi(\mathbf{x}') = 1] = 0$ .



Then  $\Pr[\psi(\mathbf{x}) = 1] - e^\epsilon \Pr[\psi(\mathbf{x}') = 1] = \Pr[\psi(\mathbf{x}) = 1] \leq f = \delta$  and  $\Pr[\psi(\mathbf{x}') = 1] - e^\epsilon \Pr[\psi(\mathbf{x}) = 1] \leq 0 \leq \delta$ .

For the event  $\{0\}$  we have then  $\Pr[\psi(\mathbf{x}) = 0] \geq 1 - f$  and  $\Pr[\psi(\mathbf{x}') = 0] = 1$  Then  $\Pr[\psi(\mathbf{x}) = 0] - e^\epsilon \Pr[\psi(\mathbf{x}') = 0] \leq 1 - e^\epsilon \leq 0 \leq \delta$  and  $\Pr[\psi(\mathbf{x}') = 0] - e^\epsilon \Pr[\psi(\mathbf{x}) = 0] \leq 1 - \Pr[\psi(\mathbf{x}) = 0] \leq f = \delta$ .

□