

SOFTWARE DEVELOPMENT FOR APS-UPGRADE LLRF

T. Madden*, N. Arnold, T. Berenc, T. Fors, G. Shen, S. Veseli, Y. Yang, W. Yoder
Argonne National Laboratory, Chicago, IL, USA[†]

E. Breeding, K. Vodopivec
Oak Ridge National Laboratory, Oak Ridge, TN, USA

Abstract

An extensive service-based software system has been developed for real-time data acquisition (DAQ) on numerous subsystems of the Advanced Photon Source (APS) accelerator. The software, called DAQ, is based upon EPICS 3 Area-Detector with added EPICS 4 services, with EPICS 3 + 4 being called EPICS 7[1],[2]. DAQ is comprised of several network services including file storage and processing as well as numerous EPICS 7 Input-Output Controller (IOC) applications that collect data and publish to EPICS 7 from accelerator subsystems, including power supplies, diagnostics, timing, and RF systems[3]. For the APS upgrade extensions to the DAQ software have been developed for digital Low Level RF (LLRF) systems supporting multiple hardware platforms including Lawrence Berkeley Laboratory's LLRF4 hardware and Micro Telecommunications Computing Architecture (μ TCA) [4]. EPICS 7 IOCs for LLRF run on multiple threads for real-time data collection, visualization, system control, and data file storage that can be triggered on accelerator beam dumps for system debug. A Python-based oscilloscope application has been developed for real-time data visualization.

INTRODUCTION

The APS at Argonne is being upgraded from its current configuration to a new Multi-Bend Achromat (MBA) lattice, called APSU [5]. The LLRF systems are being upgraded from analog circuitry to new digital LLRF. The new digital LLRF will be comprised of μ TCA hardware, with a crate housing several modules, including an FPGA-based Advanced Mezzanine Card (AMC) from Vadatech, Inc. with custom LLRF daughter boards, and a Linux blade to run control and data acquisition software [4]. While the main engineering efforts for the LLRF upgrade are in signal processing, firmware and software design, we present here a summary of the software development.

The LLRF software is one part of a larger software data acquisition and control infrastructure, collectively called DAQ. A brief overview of DAQ and its LLRF-specific components will be presented. The APSU LLRF system will support three separate machines in the APSU: Particle Accumulation Ring, Synchrotron Booster, and Storage Ring. A common software, hardware and firmware platform will be used for all three machines.

* tmadden@anl.gov

[†] Argonne National Laboratory's work was supported by the U.S. Department of Energy, Office of Science, under contract DE-AC02-06CH11357.

SOFTWARE INFRASTRUCTURE

EPICS 7

The digital control system used at APS is Experimental Physics and Industrial Control System (EPICS). EPICS is a software tool set that allows the digital control of large systems such as a particle accelerator. The EPICS system at APS includes a large collection of Input-Output Controllers (IOC), or networked computer servers that interface to hardware and publish hardware settings and controls as Process Variables (PVs). EPICS clients such as GUI applications allow the monitoring and control of the hardware components by network connection to multiple PVs. While the current version of EPICS for process control is EPICS version 3, a major addition is EPICS version 4 which allows the streaming of structured data over a network. The combination of EPICS 3 and 4 is called EPICS 7.

Area Detector + EPICS 7

Area Detector (AD) is a software tool set for EPICS control of large area detectors at synchrotron beam lines [1]. In particular, AD provides a system for acquiring data from large detectors using a "driver" that interfaces to hardware, collects data, and passes these data to a set of queues. Other components in AD, called "plug-ins," retrieve these images from queues and perform real-time processing before saving image data to disk. The DAQ software IOC is an extension of the AD IOC, in that EPICS 4 data structures relevant to accelerators, rather than images, are passed through the system of queues. AD's set of queues, multi-threading, and ability to pass large datasets in real time makes it attractive for use as a DAQ for accelerator systems.

Data Acquisition System (DAQ)

The DAQ system is a large distributed software system at the APS for data acquisition of accelerator data. DAQ is comprised of a network of EPICS 7 IOCs that interface to accelerator system hardware and collect and stream data over the network. DAQ also includes a set of network services for data storage, data routing, data processing and several other applications. Additionally, DAQ includes an interface to Self Describing Data Set (SDDS), a structured data file type used at APS for storing accelerator data[6]. Finally DAQ can interface to several mathematical software tools such as Python and Octave[7]. A simplified diagram of DAQ can be seen in Figure 1.

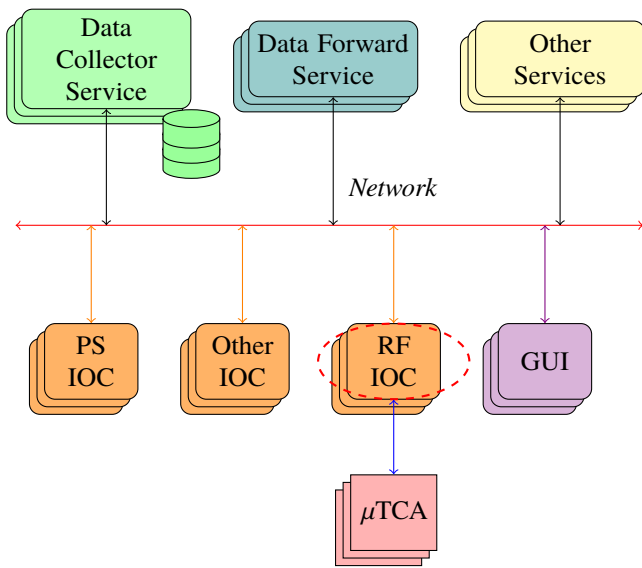

Figure 1: DAQ System showing Network Services, IOCs, and GUI Client. The LLRF IOC is circled.

EPICS 7 LLRF IOC

The new digital LLRF system for the APSU utilizes an AD-based DAQ IOC that not only controls and monitors the LLRF system, but also collects and streams data to various servers and clients on the network in real time. For the LLRF IOC, the driver gathers RF data from the APSU RF systems and passes them raw to a set of queues. DAQ plug-ins then take the raw data off the queue, format them as EPICS 4 data structures, perform real-time processing on the data before finally streaming the data to a networked file service for storage. The drivers and plug-ins can run on multiple threads in one process on a Linux computer. The networked data storage service saves RF data on one centralized server rather than at local storage scattered around the APS site. Centralized data storage allows for long term secure storage as well as centralized data processing.

μTCA PCIe Interface

The LLRF μ TCA crate houses a Linux blade running the EPICS 7 LLRF IOC as well as an FPGA-based RF card that generates and captures the RF signals in the LLRF system. Communication between the AMC and Linux blade occurs via a PCIe x4 interface. The FPGA runs firmware that implements a PCIe device on the bus. This firmware, developed by Oak Ridge National Laboratory(ORNL), allows for register-based read and writes to control "knobs" in the digital LLRF system, as well as Direct Memory Access (DMA) PCIe transfers for streaming real-time RF data from FPGA to the Linux blade.

The Linux blade runs a custom Linux Kernel Module, called OCC and developed by ORNL, that handles all transactions on the PCIe bus from the FPGA card[8]. The EPICS 7 LLRF IOC runs in the application layer and makes calls to the OCC application library to communicate with the FPGA card. For debugging, the FPGA card can be controlled at the

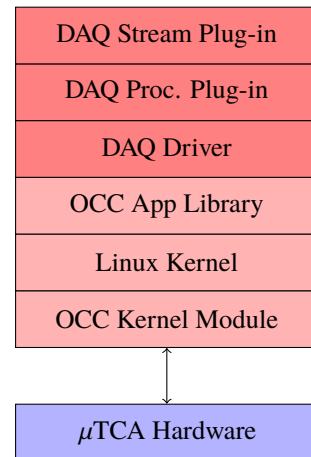

Figure 2: Software Stack in Linux blade shown in red. The Linux Kernel uses the OCC module to communicate to the μ TCA hardware via PCIe. The EPICS IOC Application, shown in darker red, calls the OCC library and is comprised of a Driver and a set of Plug-ins.

Linux command line by using the OCC command line tools. In this way, system problems can be investigated by shutting off the EPICS IOC, and directly controlling the hardware over PCIe. A diagram of the software stack is shown in Figure 2.

Automatic Screen and Code Generation

To control and read back the LLRF system, the IOC application reads and writes to FPGA registers addressed as memory via the PCIe bus. Because the FPGA firmware is under constant development independent of the software, a method was devised for keeping the software synchronised with FPGA firmware. All of the FPGA registers are documented in a spreadsheet that includes register addresses, bit fields in the registers, and whether or not the registers need to be EPICS PVs. For example, at register address 0xC00, bit 0 could be defined as turning on and off RF output from the μ TCA crate. Whenever the firmware is updated, the spreadsheet is updated to document firmware changes.

A set of python scripts has been written to read the spreadsheet and automatically generate C++ code, EPICS database files defining PVs, and GUI screens. In this way, when a new register is added to the FPGA firmware and documented in the spreadsheet, the python scripts can be run to automatically update the software source code and GUI screens. Once the python scripts are run, the IOC source code is recompiled, and the software is then able to control the new registers. By using the spreadsheet and python scripts, software and screens need not be updated by hand every time a new bit is added to the FPGA. The tool flow is shown in Figure 3.

Streaming Signals from the LLRF Control Loop

The LLRF system is a Proportional-Integral-Derivative (PID) loop to control the magnitude and phase of the RF

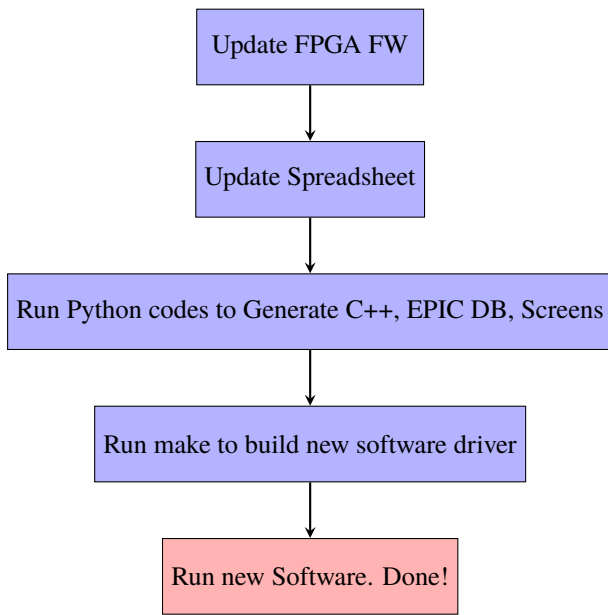

Figure 3: Work flow for upgrading FPGA and Software.

signal in accelerator cavities, as measured by cavity probes. While the current analog APS LLRF system directly controls magnitude and phase, the new digital LLRF system splits the RF signal into I and Q components, and runs a separate PID controller for each component. The software system allows control of all settings in the PID controller. Also, the LLRF firmware and software stream raw data from several points in the PID control loop for real-time monitoring, data collection, and analysis of the PID loop. A diagram of the loop, and points where data is collected by the software system is shown in Figure 4.

In Figure 4, ADC_2 digitizes the cavity probe signal which is digitally down-converted in sample rate (DDC) to create the feedback I and Q signals (FB I/Q). Typically, the ADC samples at a sample rate of 41.5MHz, and the Digital Down Converter (DDC) converts the sample rate to 2.4MHz. A further decimated version of the signal is streamed through software. ADC_1 digitizes a reference phase that is converted into I and Q (Ref I/Q) and is used to calculate the set point (SP I/Q). The feedback signal is subtracted from the set point to generate the error signal (Err I/Q) that is fed into the PID controller. The output of the PID, the Drive signal (Drv I/Q), is digitally up-sampled and converted to an analog RF signal to drive the cavity. The raw ADC signals can optionally be streamed as a diagnostic.

Software Data Stream

The LLRF DAQ is designed to simultaneously stream I/Q data in real-time for 12 sampled waveforms. The I/Q waveforms in the PID controller are inserted into data packets to be sent over the PCIe bus for DMA transfer into the Linux blade. The OCC kernel module handles the DMA transfer on the Linux blade, and allows the DAQ EPICS IOC driver to read the packets with a memory copy by calling the OCC

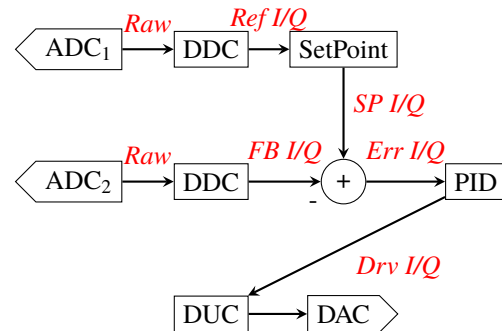

Figure 4: LLRF Control Loop showing streamed signals in red.

library and place them into a queue. The thread running the driver is set to a high priority and is assigned its own CPU core to minimize the chance of losing packets. Further, OCC supports "interrupt coalescing," or the grouping of many PCIe packets into one software interrupt, to reduce software overhead in the Linux blade.

A plug-in, called the "Parse Plug-in," grabs the packet data off the queue and decodes the binary format to create floating point arrays in EPICS4 PVData format. Also, the plug-in does real-time calculations such as converting I and Q into magnitude and phase. The EPICS 4 RF data is then stored into a 2nd queue to be read by a streaming plug-in that serializes and sends the RF data over the network as EPICS4 PVAccess protocol. Clients on the network for real-time display and the File Storage service access the streamed EPICS 4 data over the network. A diagram of the data flow is shown in Figure 5. Additional plug-ins can be added to the software to save RF data in the event of a beam dump.

When streaming raw ADC data, the 41.5MHz sample rate is too high to send more than one channel at once. Further, because of the slow network connection to the Linux blade (1Gb/sec), the ADC data is sent as blocks of 100k samples of continuous data with missing data between blocks.

Real-Time Data Rates

The AMC streams data via PCIe up to 200MB/sec. There is a streaming bottle neck in the Linux blade as it has a simple 1Gb Ethernet connection, and can only stream on the order of 10MB/sec. For saving data to files, which is a streamed over the network to the on-line data storage service, the IOC has a queuing system that can temporarily store data in case of network bottle necks. For streaming data to a real time GUI, often data is dropped.

The data rate can be throttled by setting a decimation factor in the FPGA. The DDC decimates the data by 17, converting 41.5MHz to 2.44MHz. Note that the PID loop operates at the 2.44MHz sample rate. Because this 2.44MHz sample rate is typically too high for software streaming, a programmable decimator reduces the sample rate by power of 2 decimation factors from 2,4,8..64. Typically we run with a decimation factor of 8 to produce a streamed sample rate of 305kHz. We can stream I/Q data over EPICS 4 at this

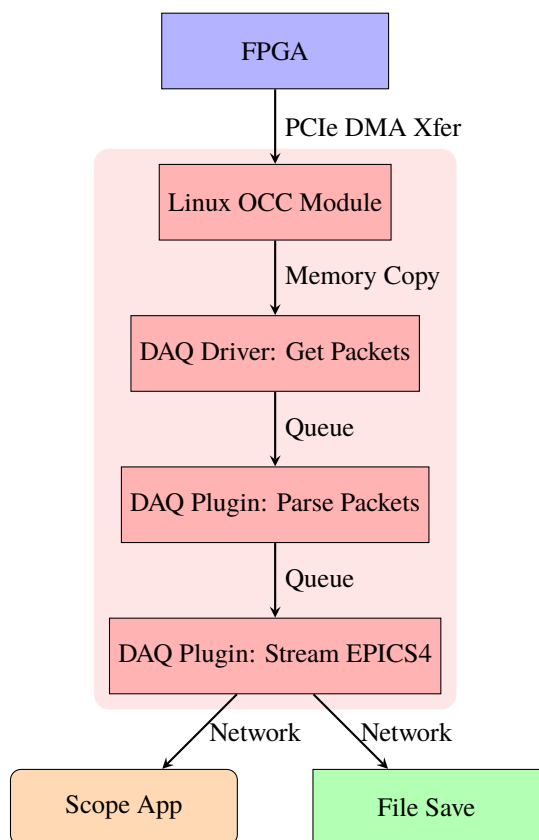

Figure 5: Data Flow in RF DAQ: The FPGA produces RF I/Q binary data and sends over PCIe Bus. In the Linux blade, all shown in red, OCC interrupts on PCIe data and stores packets in RAM. The IOC Driver copies raw packets into a Queue. A plug-in dequeues the packets and produces floating point I/Q and Magnitude/Phase RF data as EPICS 4 structures, then queues them. Finally a 2nd plug-in accepts the EPICS 4 data and streams over the network.

rate for several channels at once. For one channel the data is reliably continuous. As channels are added, discontinuities are seen in the real time GUI. Again for saving data to files, the data is continuous as the DAQ system queues data in memory before saving. For saving data to file, it is necessary to save short time periods to avoid overrunning the queues in the IOC software. Typically files with less than 3 seconds of data are saved, leaving files with continuous data. Because timestamps are saved with data, it is known in data files if data is not continuous.

GUI AND REAL-TIME DISPLAY

LLRF Loop Control

The Graphical User Interface (GUI) can be thought of as two components, the control component and real time display component. The control component is the interface that allows the set up and control of the digital LLRF hardware. This interface consists of several user screens with buttons and readouts, and is displayed by the Motif Editor

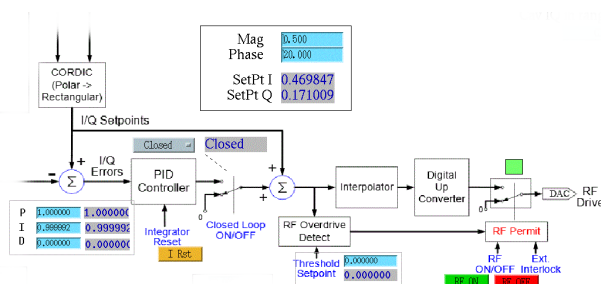

Figure 6: Portion of the PID loop user interface.

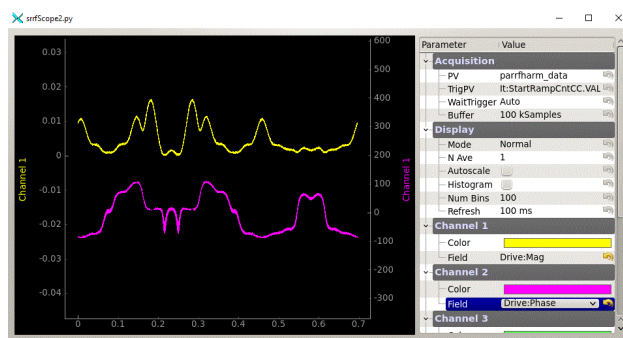

Figure 7: Scope Application displaying test waveforms.

and Display Manager (MEDM)[9]. A screen shot of the LLRF feed back loop screen is shown in Figure 6.

Scope Application

The second part of the user interface is the real time display of the RF data. An application, called the Scope Application, has been written in Python to display real time waveforms similar to a real hardware oscilloscope. The Scope Application is an EPICS4 client that receives PVData structures, in the case of LLRF that is RF I/Q data, and displays the waves on-screen. The Scope Application can update the screen at up to 10 frames per sec for real-time performance by using the PyQtGraph library [10]. Further, the Scope Application can be triggered like a hardware scope by specifying an EPICS PV. When the EPICS PV changes the scope is updated. In this way, by using for example a PV that updates for every Booster cycle, the scope will trigger synchronous with the booster operation. The jitter of the scope trigger is less than 20ms despite network delays because both the waveform data and trigger PV are timestamped by the APS timing system. A picture of the Scope Application is shown in Figure 7. The Scope is designed as a software class that can be inherited. In this way, basic functionality is written into the parent Scope class, and features specific to LLRF are written into a derived Scope class to make a LLRF-specific Scope.

The scope has several modes for displaying multiple waveforms in different colors at once, each with their own scales. Also, data can be displayed in the frequency domain, X vs. Y, or as a histogram. Plots can be averaged in time to create an averaged FFT spectrum.

DATA MANIPULATION

There would be no point in storing data without some way to manipulate data and analyze it. At the APS, a structured file format and large set of data manipulation tools has been developed, called Self Describing Data Set (SDDS) Toolkit[6]. SDDS is a binary file format developed to store accelerator data. The tool set is a large collection of Linux command line tools for performing data processing, plotting, and other forms of manipulation. SDDS can also be read by C++, Python, Matlab, and many other tools for data analysis.

CONCLUSION AND FUTURE WORK

The DAQ software system is currently running at APS and has proven crucial for machine studies and data collection for the APSU. The LLRF software, a small part of the DAQ software, is quite mature and is used for APSU-related data collection and development of the new digital LLRF system. The software will continue to be developed as the APSU progresses.

Future developments include integration of the software with a new time stamping system under development as part of APSU. Also, software specific to various accelerator machines, that is, the Storage Ring, PAR, and Booster, will be developed as APSU progresses. It is hoped that the LLRF software will support faster data rates and high speed networks for more reliable data streaming. More features for storing RF data, especially long term data such as slow storage ring phase drift, are being designed.

REFERENCES

- [1] M. L. Rivers. "areaDetector: Software for 2-D Detectors in EPICS". In: *AIP Conference Proceedings*. Vol. 1234. 1. AIP, 2010, pp. 51–54.
- [2] EPICS V4 Working Group. *EPICS 4 Website*. <http://epics-pvdata.sourceforge.net>. Accessed on 2019-09-11. Sept. 2019.
- [3] S. Veseli. "Data Acquisition System for the APS Upgrade". In: *ICALEPCS 2019*. 2019.
- [4] Vadatech Inc. *Vadatech Website*. www.vadatech.com. Accessed on 2019-09-11. Sept. 2019.
- [5] Argonne National Laboratory. *APS Upgrade Website*. <https://www.aps.anl.gov/APS-Upgrade>. Accessed on 2019-09-11. Sept. 2019.
- [6] Argonne National Laboratory. *SDDS Website*. <https://ops.aps.anl.gov/SDDSInfo.shtml>. Accessed on 2019-09-11. Sept. 2019.
- [7] Free Software Foundation. *Octave Website*. <https://www.gnu.org/software/octave/>. Accessed on 2019-09-11. Sept. 2019.
- [8] K. Vodopivec. "The Linux Device Driver Framework for High-Throughput Lossless Data Streaming Applications". In: *ICALEPCS 2019*. 2019.
- [9] Argonne National Laboratory. *MEDM Website*. <https://epics.anl.gov/extensions/medm/index.php>. Accessed on 2019-09-11. Sept. 2019.
- [10] University of North Carolina. *PyQtGraph Website*. <http://www.pyqtgraph.org/>. Accessed on 2019-09-11. Sept. 2019.