

POSITION PAPER

## Potential Key Technologies for 6G Mobile Communications

Yifei YUAN<sup>1</sup>, Yajun ZHAO<sup>1\*</sup>, Baiqing ZONG<sup>2</sup>, Sergio PAROLARI<sup>3</sup>

<sup>1</sup>*ZTE Corporation, Beijing 100029, China;*

<sup>2</sup>*ZTE Corporation, Shanghai 201203, China;*

<sup>3</sup>*ZTE Corporation, Milan, Italia.*

---

**Abstract** 5G wireless standard development culminated between 2017 and 2019. The followed world-wide deployment of 5G networks is expected to bring very high data rate for enhanced mobile broadband, to support ultra reliable and low latency services and to be able to accommodate massive number of connections. Research attention is now shifted to future generation of wireless, for instance, beyond 5G or 6G. Unlike previous papers which discuss in-length about the use cases, deployment scenarios or new network architectures of 6G, this paper focuses on a few potential technologies for 6G wireless communications, all of which represent fundamental breakthrough at the physical layer -- technical hardcore of any new generation of wireless. Some of them, such as holographic radio, terahertz communication, large intelligent surface and orbital angular momentum are of revolutionary nature and many related studies are still at the stage of scientific exploration. Some other technical areas like advanced channel coding/modulation, visible light communication and advanced duplex, while having been studied, may find wide application in 6G.

**Keywords** 6G, holographic radio, terahertz, large intelligent surface, orbital angular momentum, advanced channel coding modulation, visible light communication

---

### 1 Introduction

Since its kick-off in 2017, 5G wireless standard development has gone through two releases, Rel-15 and Rel-16. The specifications are to be finished by the end of 2019. In Rel-15, basic functionalities such as initial access, channel structure, multi-antennas and channel coding are specified, which can partially fulfill the IMT-2020 performance requirements. New technologies and scenarios like non-orthogonal multiple access (NOMA), ultra-reliable and low latency communication, vehicle-to-X communication, unlicensed operation, integrated access & backhaul, terminal power saving, positioning are added, to expand the use cases of 5G and fully support all major performance requirements. Unlike previous four generations, 5G can serve diverse applications, including the three main use cases: Gbps speed of enhanced Mobile BroadBand (eMBB), million-connection of massive Machine-Type-Communications (mMTC) and microsecond-delay 99.999% level of ultra-Reliable Low

---

\*Corresponding author (e-mail: zhao.yajun1@zte.com.cn)

-Latency Communications (uRLLC) to fulfill the need of the information society in next decade (2020-2030). The world-wide commercial deployment of 5G networks, either in non-standard-alone mode with 4G network as the anchor network, or in standard-alone mode, is expected to have significant impact on daily life of humans, the economy and culture. As in previous generations, 5G standard will continue its evolution path after 2020 ("5G+") to further optimize the features and extend the deployment scenarios like non-terrestrial networks (satellite communications) or the operating bands, for instance, up to ~114 GHz to invite more participation by vertical industry and emerging enterprises.

Since 1982, about every 10 years, wireless (or mobile) communication would undergo a generation change. Each of these 10-year cycles would start with a vision (use case & deployment scenarios) and technology research at conceptual level, followed by the standards research, standardization, proto-typing of the systems and finally the commercial network deployment. Hence, it is time to start thinking the next generation: 6G mobile communications.

In July 2018, the Network 2030 focus group was established in International Telecommunication Union (ITU) to explore the development of system technologies for 2030 and beyond. Its concepts of 6G include new holographic media, services, network architecture, Internet Protocol (IP), etc. [1]. As a part of the flagship program of the Academy of Finland, 6G-enabled wireless smart society and ecosystem (6Genesis) [2] was kicked off in 2018, with the focus on wireless technology study and 6G standard development. Its research areas span reliable, near-instant, unlimited wireless connectivity, distributed computing & intelligence, materials & antennas for future circuits and devices. United States also showed its 6G ambition through an announcement by an official of Federal Communications Commission (FCC) at 2018 Mobile World Congress [3]. In China, according to an interview with Minister of Industry and Information Technology in March 2018, the country has already begun to study 6G [4]. Elsewhere, it is reported that European Union, Japan, South Korea, Russia and other countries also started to carry out relevant work.

Use cases, deployment scenarios and performance requirements for 6G were envisioned in a number of papers [5][6][7][8]. New network architectures were also discussed [9][10]. In terms of technologies, especially at physical layer, previous generations of mobile communications are often hallmarked by certain way of multiple access, such as frequency-division multiple access (FDMA), time-division multiple access (TDMA), code-division multiple access (CDMA), orthogonal frequency-division multiple access (OFDMA) for simplicity. This just underscores the importance of technology advancements which are not only about the air-interface designs, but also various breakthrough in electronic/photonic materials, microelectronic fabrication, device manufacturing, and so on. For instance, circuit digitization makes the shift-keying signals and channel coding possible, thus significantly increases the voice capacity in TDMA based 2G (e.g., GSM) compared to FDMA-based 1G. The migration from digital signal processing (DSP) to application specific integrated circuit (ASIC) drastically elevates the processing power & density of the baseband in the base stations, which is

crucial to the capacity gain of 4G systems compared to 3G. The highly integrated circuits in baseband plus radio frequency and optical fiber domain make active antennas engineering-wise feasible and then turn the academic-world massive MIMO into the reality in 5G.

Given the rather early stage of 6G research, technology openness should be encouraged, similar to the study on use cases, deployment scenarios and performance requirements. The technology study also reflects the investment in some strategic areas of a country, which is especially the case in 5G. With the above consideration, we in this paper focus on potential physical layer technologies for 6G which include holographic radio, terahertz communication, large intelligent surface, orbital angular momentum, advanced channel coding/modulation, visible light communication and advanced duplex. Their maturity varies, some of which are still in scientific research stage. It should be pointed out that artificial intelligence (AI) or machine learning will definitely play important role in 6G and can widely be used in many technical fields. Hence, it is discussed in conjunction to above-mentioned potential technologies, rather than a separate section dedicated to AI.

This paper is organized as follows. 6G concepts are discussed in Chapter 2 briefly. Chapter 3 is devoted to four revolutionary technologies of exploratory nature: holographic radio, terahertz communication, large intelligent surface and orbital angular momentum. In Chapter 4, three more matured technologies are discussed: advanced channel coding/modulation, visible light communication and advanced duplex. The summary is provided in Chapter 5.

## 2 6G Concepts

- 6G vision

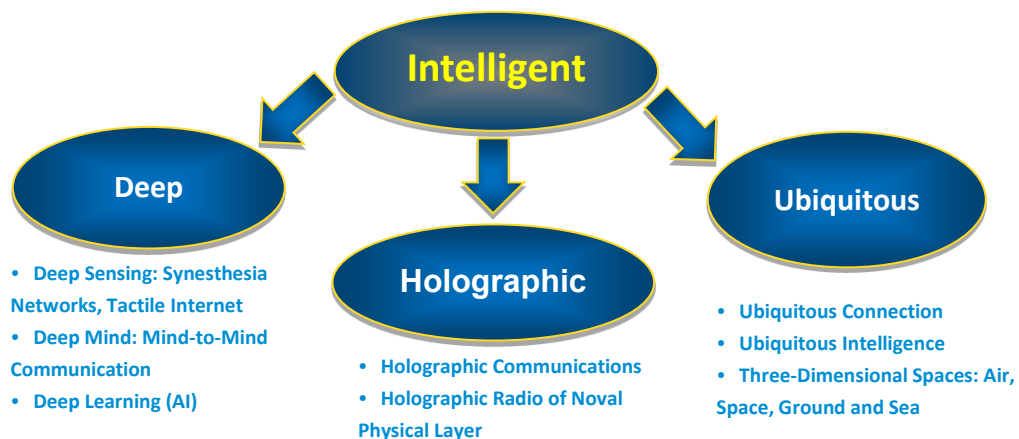

**Figure 1 6G visions**

The goal of 6G is to meet the needs of the information society ten years from now, e.g., ~2030, which would significantly go beyond what 5G can offer. 6G vision can be summarized into four key words as illustrated in Figure 1. "Intelligent Connectivity", "Deep Connectivity", "Holographic Connectivity" and "Ubiquitous Connectivity". These four keywords constitute the overall vision of 6G

which is "Wherever you think, everything follows your heart".

"Intelligent Connectivity" reflects the inherent intelligence of communication systems: intelligence of network elements and network architecture, intelligence of connected objects (terminal devices), and information support of intelligent services. 6G networks will face many challenges such as super complex and huge networks, myriad types of terminals and network devices, and extremely complex and diverse business types. "Intelligent Connectivity" will satisfy two requirements at the same time: 1) all the related connected devices in the network itself are intelligent, and the related services are intelligent; 2) the complex and huge network itself needs intelligent management. "Intelligent Connectivity" will be the fundamental characteristic to support the other three major characteristics of 6G network: "Deep Connectivity", "Holographic Connectivity" and "Ubiquitous Connectivity".

- Requirements and KPIs

In order to realize the vision of 6G network and meet the demand of future communication, the following key requirements and challenges need to be considered.

- Peak rate: Terabit Era, ~10 terabits per second
- Universal low delay and reliability connection
- Higher efficiency of energy use for communications
- Connection everywhere and anytime
- Ubiquitous intelligence
- Versatility: to accommodate different types of networks in dynamic and organic ways
- Convergence of communication, computing, sensing, and control
- Non-technical challenges: industry barriers, policy and regulation, consumer habits

- Enabling technologies

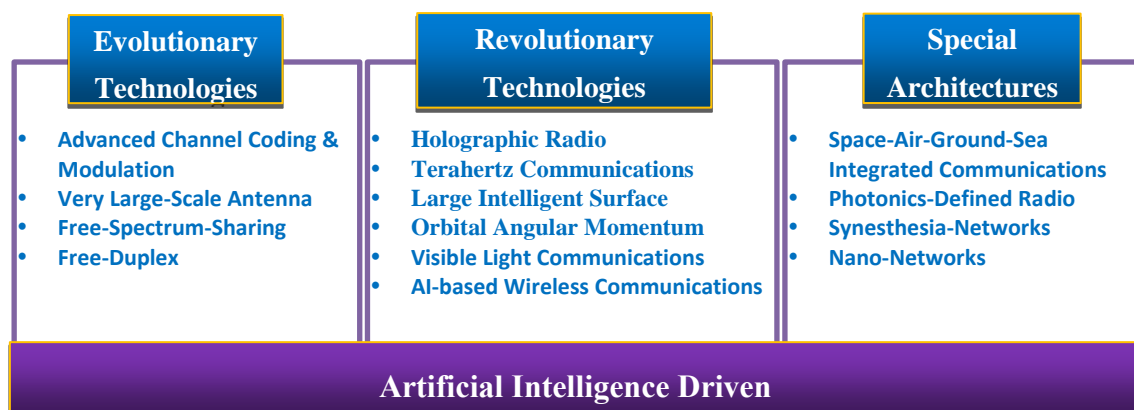

**Figure 2 6G potential key technologies**

At present, the concept of 6G is still in the early stage of discussion, and the views given by

various countries are quite different. To achieve the 6G vision and counter the challenges mentioned above, considering the development status and trends of related technologies, we believe that the potential key technical features of 6G can include the following aspects as shown in Figure 2.

### 3 Potential Revolutionary Technologies

The technologies to be discussed in this chapter are revolutionary in the sense that they would fundamentally change the physical layer of mobile communication systems compared to 5G. Many aspects are still at the stage of scientific exploration. Yet, they indeed represent the level of science & technology development of a country in cutting-edge strategic areas.

#### 3.1 Holographic radio

For a long time, interference has always hindered the performance and quality of service (QoS) in modern wireless communication systems. Traditional methods aim at minimizing, eliminating or avoiding interference. Contrary to the conventional view that interference is regarded as harmful, 6G would treat interference as a useful force for developing energy efficient and secure communication systems. One of the most promising interference-exploiting technologies is the computational holographic radio. On one hand, interference exploitation achieves the gains by exploiting interference in wireless networks through large-scale cooperation between distributed transceivers, and by enabling high spatial multiplexing gain via multiuser transmissions [11]. On the other hand, RF holography and spatial spectral holography show potential in interference exploitation by full-space spectral coordination [12][13]. However, these technologies seem to focus on uplink signal processing such as imaging and RF mapping. Combining spatial spectral holography with spatial wave field synthesis, holographic radio can not only achieve fully closed-loop and precise control of the electromagnetic field, but also greatly improve the spectrum efficiency and network capacity, and facilitate the integration of imaging and wireless communication.

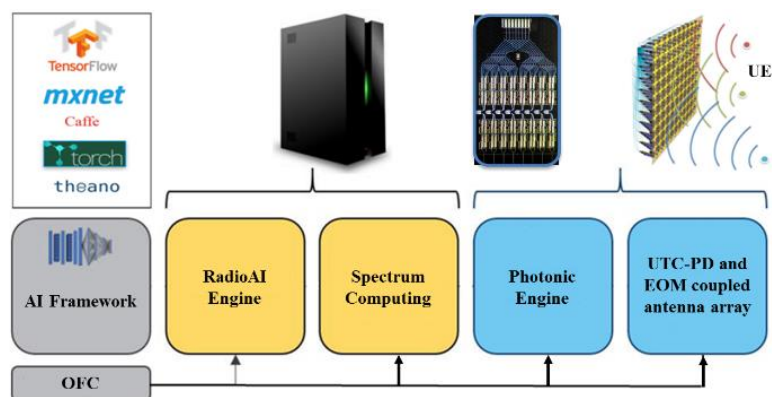

**Figure 3 Hardware architecture of computational holographic radio based on photonics defined radio**

Computational holographic radio is built upon a photonics-defined radio (PDR) platform. Figure 3 is the hardware architecture of computational holographic radio. The photonic front-end (PFE) or photonic antenna array (PAA) performs the transmission, reception and conversion of optical or RF signals. The photonic engine (PE) performs the signal generation and processing in the optical domain. The modules inside the spectrum computing (SC) include signal simulator, channel simulator, wave field synthesis module and deep cognitive radio engine.

In the uplink of computational holographic radio, spatial-spectral holography is responsible for converting the RF signal transmitted by the terminal from each antenna element to the frequency range of optical spectrum through an electro-optical modulator (EOM) coupled antenna array. Then the optical signal outputs are aggregated into an optical Fourier Transform processor. Finally, the optical signals processed by holographic interference are converted back to electrical signals via a two-dimensional addressable photo-detector. Up to this time, signals from different terminals have been well separated, and the whole processing is similar to a real-time three-dimensional "light" field imaging in RF domain. Moreover, a rather limited RF aperture has been transformed into an almost infinite optical aperture, which enables RF signals to be pre-coded and multiplexed in a nearly continuous spatial spectrum, thus achieving extremely high data throughput and multiplexing gain. Meanwhile, a three-dimensional RF "phase space" can be obtained through spatial spectral holography, offering precise feedback for "spatial wave field synthesis" in the downlink. Figure 4 shows the function modules of antenna array, photonic engine and spectrum computing of computational holographic radio.

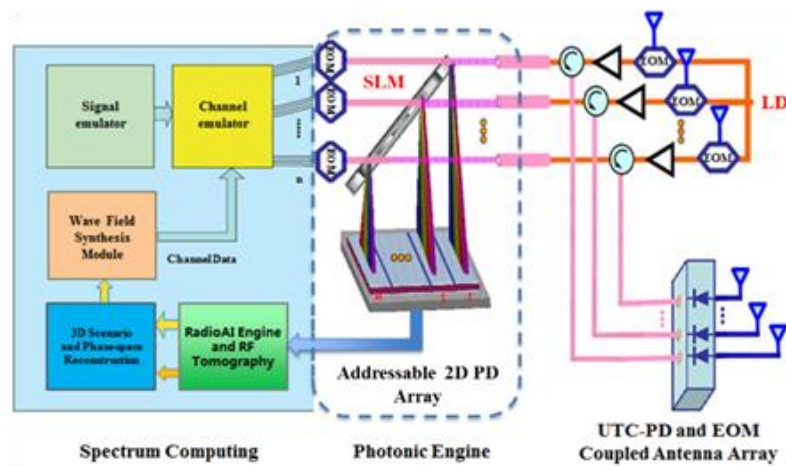

**Figure 4 Function modules of antenna array, photonic engine and spectrum computing of computational holographic radio**

The downlink "spatial wave field synthesis" is responsible for precise control over multiple modules, including signal simulator, channel simulator and wave field synthesis module, based on the "phase space" of each mobile terminal built up by the "spatial spectrum holography". The complex and accurate distribution of electromagnetic field in target space is achieved by a series of photo-detector

coupled antenna arrays that are controlled by signal simulator, channel simulator and wave field synthesis module to transmit specific RF signals. The whole process is similar to a real-time holographic "light" field projection in RF domain. Figure 4 is a functional model and architecture for the synthesis of space wave fields.

In order to achieve the above spatial spectral holography and spatial wave field synthesis, the transmission aperture of the antenna array should be flexible, that is, to be able to radiate the distribution of holographic RF signals. To cope with this challenge, a photodiode coupled array antenna is required, in which the current source of the excited coupled dipole element is photodiode. Due to the inherent planar dipole structure and the potentially infinite bandwidth of the current sheet, the antenna has the capability of maximizing the relative bandwidth, the scanning angle and the low profile performance. High power uni-traveling carrier photo detector (UTC-PD) is bonded to the antenna units by flip chip technology, creating the coupling between antenna units. The output current of UTC-PD directly drives the antenna unit, so that the whole active antenna system has a maximum bandwidth of about 40 GHz [14]

### **3.2 Terahertz communications**

Terahertz frequency band ranges from 0.1 to 10 THz, which is the last span of radio spectrum and generally considered as a Terahertz Gap. Terahertz band is envisioned to be able to provide with up to Tbps data speed to satisfy extremely high throughput, low latency and completely new application scenarios for 6G [15][16]. The first project in IEEE 802 towards 100 Gbps, IEEE 802.15d, was approved in March 2014, although there is no commercial plan based on this standard. The unique characteristics of the terahertz band, such as high path loss, scattering, reflection and so on, pose many new challenges that need to be addressed before achieving the Tbps (Terabit/s) links.

- **Characteristics of terahertz bands**

The main characteristics of terahertz band are as follows: (1) huge bandwidths (>50 GHz) available at THz frequencies; (2) severe path loss even for free-space propagation, e.g., ~100 dB at 300 GHz at the distance of 10 m; (3) excessive attenuation due to resonance of molecules in the air. However, there are several atmospheric windows, e.g. 140, 220, 340GHz [17] where the attenuation due to molecule resonance is only about 2 dB/km, negligible compared to the free-space attenuation. It should be noted, when the frequency exceeds 1 THz, the radio wave undergoes a significant absorption by water vapor and oxygen molecules in the atmosphere, and can be attenuated ten times at 1-m propagation distance [18]; (4) sensitivity to shadows and blocking due to its mild diffraction effect at such short wavelength. For example, the signal attenuation of brick is as high as 40-80 dB and the human body can cause 20-35 dB signal attenuation; (5) less sensitivity to humidity/rainfall, e.g., attenuation becomes relatively flat above 100 GHz; (6) super fast channel fluctuation and intermittent connection, e.g., the coherence time of the terahertz band is very short and the Doppler frequency is very large; (7) wide use of highly directional antennas (~25 dBi); (8) extremely high instantaneous

processing power. A major challenge in utilizing very large antennas is the power consumption of broadband terahertz system (A/D) conversion. Power consumption is generally proportional to the sampling rate, and exponentially grows with sampling number per bit.

However, the manufacturing of THz components has become more mature and some commercial products are able to emit power of 0-10 dBm at 300 GHz. It is expected that higher output power can be achieved in near future. Moreover, simple modulation schemes (e.g. BPSK, QPSK) would be enough for high data rates (>100 GBit/s), given the huge bandwidths of THz bands at least in the first stage. Therefore, terahertz communications have an opportunity to be applied in the 6G era, and we can look forward to further improving performance with some key technology breakthroughs.

- **Targeted application scenarios**

The terahertz communication scenarios can be classified mainly into: macro-, micro- and nano-scale networks. Macro-scale networks are used primarily for the applications in which the transmission range is from about 10 meters to few kilometers. Micro-scale networks are typically for the applications with limited transmission range (less than few meters, e.g.  $\leq 10\text{m}$ ). Nano-scale networks are more suitable for the communications within a range of below 1-meter or centimeters.

Macro-scale networks are mainly for outdoor scenarios and the typical applications can include vehicular, backhaul/fronthaul connectivity, and so on. These applications would require a wider coverage (e.g., 10 m to few kms) and high throughput (up to 1 Tbps) with low latency (e.g., < 1 ms).

Regarding the micro-scale networks, they can be further categorized mainly into outdoor and indoor scenarios. For indoor scenarios, they can support the applications which require mobility as well as the applications with fixed point to point or multi-point connections, like indoor small cells, WPAN (Wireless Personal Area Network), wireless connections in Data Centers and Near-Field Communications (NFCs) such as kiosk downloading. While for outdoor scenarios, the applications can include vehicular, small cells and backhaul connection. And the outdoor applications are different from the indoor environment, which is largely due to reflections and scattering phenomenon with path and absorption loss. Therefore, these indoor and outdoor scenarios require different propagation models respectively to represent different obstacles, scattering, and atmospheric losses.

Nano-scale network is a brand new network topology suitable for extremely short wavelength. In nano-scale network, communication is usually for the distance within 1-meter or centimeters (e.g. inter-miniature-device links, on-chip and chip-to-chip links, in-body communications). The main challenges include the novel transceiver design for nano-scale devices, channel models for the new environments of the nano-scale networks, physical layer solutions including channel coding and modulation schemes, and communication protocols.

In addition to the above three terrestrial scenarios, outer space communications are also important scenarios of terahertz communications, which have been applied in the field of space science for many



years. In outer space, terahertz wave has relatively transparent atmospheric windows such as near 350, 450, 620, 735 and 870 microns. The transmission would experience little moisture-induced absorption so that long-distance communication becomes feasible at terahertz.

### ● **Key Technologies Aspects**

Although the technology for terahertz communication is evolving rapidly in the areas of transceiver architectures, materials, antenna design, propagation measurement, channel modeling, and physical layer techniques, there are still many challenges to be addressed before Tbps links can be practical. The key enabling technologies for THz communication are as follows at least.

- Propagation measurement, and channel modeling
  - Different characters of the scattering and reflection due to the shorter wavelength
  - Molecular and water vapor absorption, atmospheric windows
  - Indoor, outdoor, intra-device, in-body and outer space
- THz signal generation and detection (transmitter and receiver design)
  - Electronics-based approach and photonics-based approach, considering transmitting power & power efficiency, complexity, cost, size, etc.
  - Semiconductor technology, meta-materials, e.g. graphene-based electronics [19]
- Antenna technologies
  - Nano-materials and meta-materials for plasmonic antenna arrays, e.g. graphene-based antennas [20]
  - Synchronization mechanism, such as high-speed and high-precision acquisition and tracking mechanism, x synchronization mechanism for antenna arrays with hundreds or thousands of antenna elements
- Ultra-Massive MIMO for THz band, leveraging LISs-assisted smart radio environment
  - Beamforming to overcome the severe path-loss.
  - Spatial multiplexing for high data rate in short-range/nano-communication
  - Leveraging large intelligent surface (LIS)-assisted smart radio environment to overcome the blockage issues due to the directional beam (details of LISs refer to Section 3.3).
- High-speed baseband signal processing technology

- Research on high-speed baseband signal processing technology with low complexity and low power consumption and integrated circuit design to develop terahertz high-speed communication baseband platform.
- Baseband design
  - Waveform, e.g. single carrier for lower Cubic Matric (CM)
  - Modulation and channel coding
  - Multiple access (e.g, OMA, NOMA)

Among above mentioned aspects, transmitter design for THz is the most critical. There are two types of devices that can perform conversion to terahertz signal, including electronics-based devices and photonics-based devices. A key aspect of terahertz communication is carrier frequency generation where two approaches are in study: photonics-based, and electronics-based.

Photonics-based techniques offer the unique opportunity to ensure a high modulation index obtained with optical-to-THz conversion using photo-mixing, high-speed amplitude and/or phase coding introduced from optical coherent network technologies. A unique feature of using photonics devices is the possibility to easily address multi-carrier transmission by adding optical laser lines to the optical driving signals. Using photonics-based approaches, THz communication systems are capable of delivering high-rate data over wireless links. Due to the intrinsic high propagation loss at higher carrier frequencies and the low power generated at these frequencies by photonic sources, so far, the transmission distance is usually within a very short range (e.g. about 10 meters at 409 GHz [21]). To tackle the power limitation of photonics devices, the future photonics-based THz systems may be based on the combination of power amplifiers associated with photo-mixers, but performances would require a monolithic association of the two devices, which has not been achieved in the THz range. In the perspective of photonics-based THz transmitters for spectrally-efficient data links, the optical feed or source deserves special attention. Indeed, the spectral content of the THz signal is directly related to the two optical laser lines driving photomixing devices such as photodiodes. Ultimate performance would depend on the optical feed featuring low jitter and narrow linewidth in the optical domain.

Correspondingly, the electronic-based approaches are now feasible for most of the 100-150GHz band wireless links. These approaches attract significant interest due to the room-temperature operation, compact size, and potential of chip integration. In these approaches, frequency multiplication is the most commonly used method to generate terahertz frequency signals. Up to now, at frequencies above 100 GHz, GaAs and InP ICs have been key players in all-electronic THz communications research. This is mainly due to the high cutoff and maximum frequencies of transistors. However, other technologies are also good candidates for practical THz communications, and mass production compatible chipsets are now pursued by many companies and institutes. For example, Si-IC technologies have started to show their THz potential in the last 2-3 years. The major limitations on Tx

and Rx of electronic-based approaches for THz communication system include,

- the nonlinear behavior of multiplier chains which limits the modulation to be amplitude only,
- the limited modulation index if the modulation is conducted with a sub-harmonic mixer at source output and,
- the relatively high impedance ( $\sim k\Omega$ ) of Schottky barrier diode-based direct detectors that limit achievable bandwidths, even if some trans-impedance amplifiers integration can partially overcome this limitation.

Among these approaches, the highest data rates have been reached by using photonics devices as transmitters, combined with cutting-edge III/V THz electronic devices as receivers.

In addition to the pure photonics-based approaches and pure electronic-based approaches mentioned above, combined mechanisms were also studied. The combination of photonics and electronics active devices, a truly microwave photonics approach, can benefit from the intrinsic advantages of each of the two technologies such as tunability, fiber compatibility, and power handling capability.

The best scenario can be chosen based on the required data rate, distance, and sensitivity, which can benefit from the main key features of each, bandwidth, tunability, stability and fiber compatibility from photonics and power handling capability from the electronics. For example, for long-distance communication scenarios (e.g. >100 meters), electronics-based approaches with higher Tx power may be suitable. While, for hotspot/indoor scenarios and nano-communications (e.g. less than ten meters), photonics-based approaches with lower Tx power could fit better.

In addition, the ITU has decided to classify 0.12~0.2 THz as wireless communications [22], but the rules for the monitoring of the spectrum above 0.3THz are not well developed and have not yet been unified globally. It requires the joint efforts of ITU and WRC to actively promote the global consensus.

### **3.3 Large intelligent surface**

Drastic improvement in spectral efficiency, one of the key 6G requirements, can be achieved by exploiting the combined benefits of a high spatial multiplexing gain from massive MIMO and high bandwidth of THz band. However, a large number of radio frequency (RF) chains operating in high-frequency bands will lead to excessive complexity of signal processing, extremely high power consumption and prohibitive hardware cost. Large intelligent surface (LIS) is a promising energy-efficient and cost-effective solution to tackle the above challenges. It is envisioned that an initial leap from traditional massive MIMO towards LISs can provide LIS-assisted smart radio environments and generate a completely new network paradigm for 6G networks [23][24] as seen in **Figure 5**.

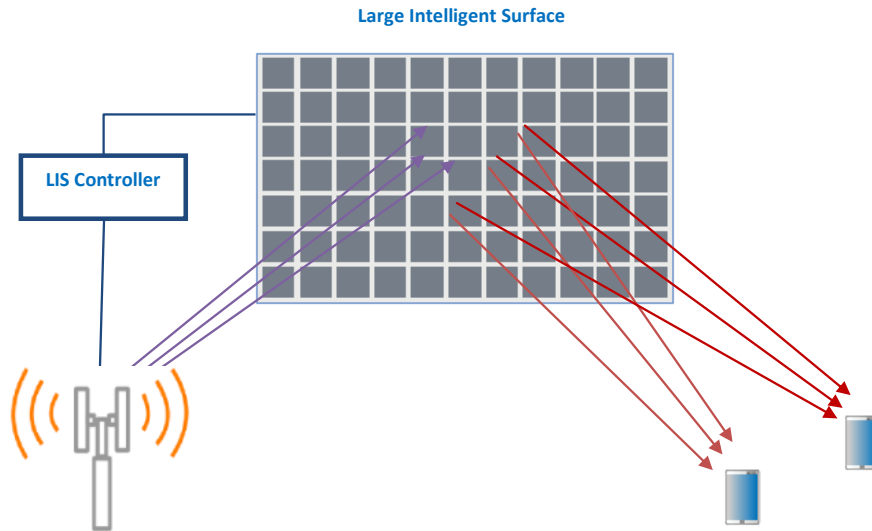

**Figure 5 LIS-assisted smart radio environments**

- **Comparison with traditional technologies**

An LIS is an artificial surface made of electromagnetic materials that can change the propagation of incoming and out-going radio waves. It is significantly different from other traditional technologies such as massive MIMO and amplify-and-forward relay (AF-relay).

LIS can be seen as an extension of massive MIMO, but it scales up beyond the traditional antenna array concept. LISs are different from the massive MIMO due to their different array architectures (passive versus active) and operating mechanisms (reflecting versus transmitting). LISs can achieve unprecedented massive MIMO gains while consuming very low energy due to the passive nature of the elements [25]. In [26], the information transmission capability of LIS was analyzed where the authors proved that the capacity per square meter surface area of LIS is linear with the average transmit power, rather than a logarithmic relationship in the case of large-scale MIMO deployment.

Although LISs resemble the classic AF-relays, there is a big difference between them [27]. Relays are made of active elements (e.g., power amplifiers), which reduce the achievable link rate if they operate in half-duplex mode, or are subject to severe self-interference if they operate in full-duplex mode. While, LISs acting as reconfigurable reflectors with passive elements have the advantage of low power consumption since it only reflects the signals passively without requiring active RF chains. In addition, they are not affected by the self-interference and the noise amplification effects, which are the two most important shortcomings of the AF-relay.

In addition, the passive reflectors, as the key components of LISs, have been used in radar systems. However, in the radar systems the phase shift of passive elements cannot be changed once they are manufactured, which makes them difficult to be used for the wireless channels that are often time-varying. In fact, for 6G, each of LIS's passive reflectors can independently tune the phase shift of the signal incident on it, thereby creating a favorable wireless transmission channel. By properly tuning

the phase shift by using an LIS controller, the reflected signal can be added constructively at the desired receiver to enhance the received signal power, while suppressing the reflected signal at the undesired receiver to reduce co-channel interference.

- **Advantages**

LISs are made of low-cost passive elements that do not require any active power sources for transmission. Their circuitry and embedded sensors can be powered with energy harvesting modules as well. They primarily rely on the programmability and re-configurability of the intelligent meta-surfaces, and on their capability of appropriately shaping the radio waves impinging on them. They can operate in full-duplex mode without any self-interference, they do not increase the noise level, and do not need any backhaul connections to exchange traffics.

The freedom of controlling the response to each LIS and choosing its location via a software-programmable interface allows the optimization of wireless networks agnostic to the underlying physics of wireless propagation and the meta-materials. It enables the seamless integration of LISs into software networks. Further information about the programmability via software and the integration of LISs into software networks can be found in [28]. Compared with other solutions, the use of LISs has enormous economic impact, e.g., they reduce the waste of resources, and offer more accurate control of the radio waves, and better deployment scalability.

By intelligently tuning the phase shifts induced by the elements of LISs, the LISs can achieve many communication objectives, such as overcoming unfavorable propagation conditions, enriching the channel by introducing more multi-paths and increasing the coverage area, while consuming very little energy. For example, the high-frequency systems, including millimeter-wave and beyond 100 GHz communications (i.e. THz bands), can take advantage of LISs as a source of controllable reflectors that can mitigate NLOS propagation conditions. It can act as reconfigurable reflectors to establish strong NLOS links where LOS is not available or it is just not sufficiently strong to achieve good connectivity, and by which the coverage and rate of the wireless systems are improved.

Furthermore, LISs have other advantages, such as low profile, lightweight and conformal geometry, which make it easier to attach/remove from walls or ceilings, thus providing a high degree of flexibility and superior compatibility for practical implementation. With all these characteristics, LISs can be embedded into man-made structures (such as walls, ceilings, roads, and even the entire building), as well as natural objects in some scenarios, to enable smart radio environments.

All the above advantages render LISs an appealing solution for performance enhancement in 6G networks, especially for indoor applications with a high density of users in some scenarios such as stadiums, shopping malls, exhibition centers, and airports.

- **Key enable technologies**

There are many challenges that need to be addressed before smart wireless environment can be achieved.

- Meta-surface design, to research on a more flexible and powerful programmable LIS.
- LISs-based wireless network paradigm and deployment.
- LIS channel sensing/feedback and controlling, such as channel state information (CSI) measurement, analog beamforming using LISs.
- Combining with massive MIMO, terahertz and other related technologies. E.g. LIS-assisted massive MIMO.

From the perspective of network deployment, the LISs-assisted network introduces a new paradigm. How to optimize the deployment of the LISs-assisted network with passive reflectors and meta-surfaces is a new challenge. One solution is the AI-powered operation of reconfigurable LIS. Fundamental analysis is needed to understand the performance of LIS and smart surfaces, in terms of rate, latency, reliability, and coverage,. Another important research direction is to investigate the potential for using LISs-based reflective surfaces to enhance the range and coverage of tiny cells and to dynamically modify the propagation environment.

In order to materialize the concept of the smart radio environment, a key problem to be addressed is that in order to configure and optimize the environment according to network conditions, the amount of sensing data collected on the meta-surface and the amount of feedback for the overall network controller can be huge. Effective solutions need to be developed to reduce the amount of sensing data required for network optimization, while enough information to network controllers with low overhead and high energy efficiency. In [29], a novel approach by leveraging tools from compressed sensing and deep learning is proposed to solve the problems with low-complexity hardware architectures and low training overhead.

### **3.4 Orbital angular momentum communication**

Orbital Angular Momentum (OAM), known as "vortex electromagnetic wave", has attracted much research attention [30]. Different from traditional PE wave based signals, radio vortex signals have the phase rotation factor  $exp(-jl\phi)$ . The main advantages of OAM are that the electromagnetic wave characteristics associated with beam vorticity and phase singularity can have unlimited number of eigen-states (i.e. OMA modes) which are orthogonal to each other, and therefore, multiple channels are allowed to increase transmission capacity and spectral efficiency in principle [31]. OAM opens up a new dimension for electromagnetic wave multiplexing transmission, which bridges a new way to significantly increase spectrum efficiency and is expected to be used in future wireless communications networks (6G).

At first, the study on OAM mainly focused on the field of optical communication. Until the last

decade, low-frequency electromagnetic wave was considered for OAM, namely microwave, millimeter wave and terahertz band. In [30], Thide first proposed the application of photon orbital angular momentum to low frequency. Through simulation, it is proved that the phased array antenna can be used to generate eddy electromagnetic waves similar to Laguerre-Gauss eddy beams,. In recent years, some experiments have proved the feasibility of wireless communication based on OAM [32][33]. In [34], the author proved experimentally and theoretically that the combination of MIMO-based spatial multiplexing and OAM-based multiplexing can improve the spectral efficiency of wireless communication. In this paper, the author proposes a method of rotating OAM electromagnetic wavelength distance transmission, and successfully carries out the first 27.5 km transmission experiment in the world [35].

Due to the introduction of a new resource dimension, some traditional wireless communication concepts may need to be updated, and related mechanisms can be redesigned accordingly. There are three basic advantages regarding OAM based wireless communications such as (1) high spectrum efficiency via new domain of OAM-modes; (2) more users access since OAM provides a novel multiple access method, i.e., mode division multiple access, without consuming more frequency and time resources; (3) high reliability for anti-jamming due to OAM can not only be used within the narrow band, but also jointly used with frequency-hopping in wide band to improve the ability of anti-jamming for wireless communications.

- **Comparison with Conventional MIMO**

In [36], it claims that radio communication over the sub-channels given by OAM states is only a subset of the solutions offered by MIMO. In [37], it was verified that, with the constraints of the receiver size, an OAM based MIMO radio system is equivalent to conventional MIMO systems from the perspective of channel spatial multiplexing. So far, no one has proved that a practical OAM utilized multiplexing link has a better performance of capacity than the conventional MIMO methods. However, unlike the plane waves used by MIMO, OAM waves have a wave vector in the azimuthal direction. Through this particular wave vector, OAM based MIMO system can be seen as a spacing-increased conventional MIMO system. Therefore, OAM based MIMO system will have a great potential in massive MIMO method which requires a great number of antennas and limited spatial spacing between antennas. OAM based MIMO is also very suitable for the communications in open area or long-distance communications where the multi-path effect is weak and conventional MIMO does not work anymore. For example, it is found that this kind of OAM based MIMO system can increase communication distance for line-of-sight (LoS) MIMO channel if the OAM states as the elements of the transmitting ULA are sorted in an ordered sequence. Although the theoretical maximum capacity limitation of MIMO system cannot be broken, by adopting OAM waves, the spatial correlation of LoS channel becomes lower, hence the capacity increases.

- **Technological Challenges and Future Research**

The feasibility of wireless communication based on OAM was validated, however, there are still many unresolved research issues, which need further research and breakthroughs. To further promote the application of OAM in future wireless communications, there are three aspects that need to be studied comprehensively and thoroughly.

Multiplexing and de-multiplexing of the OAM radio waves. The multiplexing and de-multiplexing of the OAM radio waves are the big bottlenecks for the OAM based wireless communication. The OAM optical beams can be deftly multiplexed and de-multiplexed. However, when it comes to the radio frequency regime, as the wavelength is much longer than the optics, it is difficult to manipulate the OAM radio beams, such as beam combining and splitting, so that the coaxially transmitting cannot be easily ensured. The specially designed devices are needed and may bring great insertion loss in the link, which will reduce the efficiency [38].

Radio Vortex Signal Transmission. Three typical problems need to be considered for radio vortex signal transmission. (a) Transmitter-receiver alignment. It is required that the transmitter and receiver are aligned with each other to decompose signals with different OAM-modes. for non-aligned scenarios, it is demanded to add phase turbulence adaptive estimation algorithm at the receiver. (b) Fading. There exists fading such as atmospheric turbulence, rain and fog, etc [39]. leading to the randomness of wavefront phases at the receiver. (c) Convergence. An OAM beam becomes more and more divergent as the order of OAM-mode increases, it severely reduces the transmission distance and decreases the spectrum efficiency of OAM based wireless communications. It is required to make OAM beams convergent so that all OAM-modes including both high and low order OAM-modes can be efficiently used.

Radio Vortex Signal Reception. At the receiver, the phase detection is a key to distinguish the order of different OAM-modes. How to effectively separate and detect the information modulated on the eddy electromagnetic wave is one of the great challenges. The radio vortex signal reception schemes for SPP antenna, UCA antenna, as well as other schemes i.e. the phase gradient method (PGM) is developed to identify the OAM-modes.

There are other problems that need to be considered, including limited number of available OAM-modes and joint OAM-mode and frequency/time partition.

Although OAM beam is vorticose hollow and divergent, the divergence of OAM beams greatly reduces as the frequency increases. Thus, it is expected to use OAM in the networks with high frequency such as terahertz bands.

## **4 Potential Technologies with More Maturity**

The technologies in this chapter reach certain maturity compared to those discussed in Chapter 3. Nevertheless, significant changes at the physical layer are still needed to support or accommodate these



technologies.

#### 4.1 Advanced channel coding & modulation

As fundamental physical layer technologies, channel coding & modulation provide efficient ways for a radio link to operate near its channel capacity, while making the signal waveforms friendly to RF and baseband components at transmitters and/or receivers. Since 2G, almost each generation is marked with or dominated by a new channel coding scheme, for instance, convolutional codes in 2G, Turbo codes in 3G, enhanced Turbo codes in 4G, LDPC codes and Polar code for 5G. In the general sense, channel coding and modulation encompass many specific fields that may touch waveform or even multiple access. The mathematic tools are also very diverse, for example, combinatory algebra and number theory for channel coding, linear algebra for waveform, detection theory for modulation, so on.

- **Channel coding**

Traditionally, channel coding design assumes single link connection whose channel can be binary symmetric, binary erasure, additive white Gaussian noise (AWGN), etc. The performance target is the Shannon Limit of single link channel. Such design makes sense in many mobile systems since 2G, since the primary multiple access schemes are orthogonal where different users (at least served by the same base station) occupy different time-frequency resources, or in non-overlapped spatial domains. However, in order to increase the system capacity and to serve more number of connections, non-orthogonal multiple access can be used as a complement to orthogonal multiple access. This opens an entirely new area: multi-user oriented channel coding, which can be considered as a significantly enhanced version of interleaver-division multiple access (IDMA). It is new also in the sense that channel capacity of multi-user channel is not entirely known or proved, especially for the uplink with near-far effect and various fading. In theory, any channel code can be considered with the purpose to increase the capacity of multi-user channel, as long as the code itself can provide enough room for optimization, e.g., from single-user to multi-user as illustrated in Figure 6. Recently, multi-user LDPC codes were proposed for uplink non-orthogonal transmission [40]. The reasons of considering LDPC codes are as follows. Firstly, quasi-cyclic binary LDPC is already specified in 5G as the channel coding scheme for data channels. Its performance superiority and low decoding complexity are well demonstrated for medium and long code blocks, compared to other major channel coding schemes. For multi-user channel, the receiver complexity is generally higher than that of single-user. Thus codes with low decoding complexity would be very attractive; Secondly, LDPC has many design flexibilities, in particular, the proto-matrix for parity check, the matrix lifting and the shifts. With proper choices of those parameters, binary LDPC has great potential to offer performance benefit for multi-user channel.

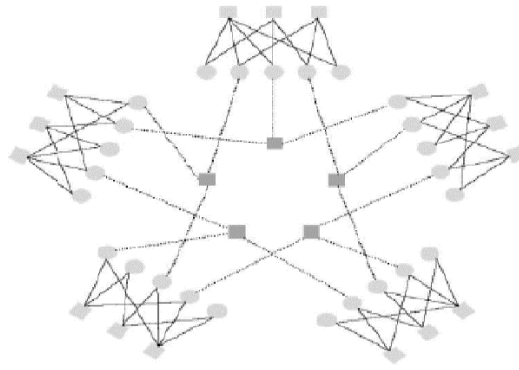

**Figure 6 Bi-partite structure for multi-user LDPC**

In previous generations of mobile communications, most of channel coding schemes at physical layer operate in binary domain. To increase the robustness of the channel codes in fading channels and to operate at very high signal to noise ratio (SNR) scenarios, non-binary (also called multi-variant) codes can be considered. Two types of multi-variant codes are already prominent. The first one is multi-variant LDPC proposed by Davey and MacKay [41]. Such codes are defined in Galois field  $GF(q)$ . The basic design of multi-variant LDPC resembles to that of binary LDPC, e.g., parity matrix can be randomly constructed, or follow certain defined pattern such as quasi-cyclic, with belief propagation or its variants as the basic decoding algorithm. Its design complexity and decoding complexity are generally higher than that of binary LDPC. But its ability of removing “short loop” in the partite graph of parity matrix allows the code to effectively combat the bursty errors. The second type of such codes is the lattice code. A very promising variant of lattice code is the low density lattice code (LDLC) [42] which can also be represented as Tanner graph and parity check matrix. Therefore, belief propagation algorithm can be used whose decoding complexity grows only linearly with the length of code block.

Most of channel codes are designed with limited choices of coding rate where the performance of the codes can be optimized for specific code rates. While it can support many coding rates, quasi-cyclic LDPC for 5G is still not rate-less. Spinal codes [43] are true rate-less codes that can provide consistently good performance over a wide range of code rates. The attractiveness of spinal codes also lies in the near-Shannon capacity performance when the code block is short, as well as the superior performance when SNR is very high.

Simple enhancements of 5G LDPC codes or Polar codes, or 4G turbo codes or convolutional codes can also be considered, for example, to improve the performance when the code block length is short for the traffic channels, to make the performance more robust in variety of environments.

- **Modulation and spreading**

It is well known that the distribution of QAM constellation points is far from Gaussian. Capacity wise, QAM is not a perfect choice even though its signal generation and demodulation are simpler than

many other modulations. Amplitude phase shift keying (APSK) has been used in various broadcasting networks and satellite communications. APSK is very robust to the nonlinearity of power amplifier. APSK can also tolerate higher level of phase noise, compared to other modulation schemes. Therefore, APSK may find its use for high frequency communications like deep millimeter wave and Terahertz.

Sometimes, modulation and channel coding can be designed jointly, as of trellis codes. Good design of joint coding and modulation can minimize the information loss between modulation and channel coding when they are designed separately, and detection and decoding are carried out separately. Its performance benefit is more pronounced when SNR is high. One important criterion is the receiver complexity which should be well contained, e.g., not too much higher than that of traditional receiver.

For very high SNR operating point, fast-than-Nyquist (FTN) [44] is also a good candidate. Fast than Nyquist sampling increases the spectral efficiency. However, it comes at the cost of the introduction of inter-symbol interference (ISI) which needs to be suppressed or cancelled out. In this sense, FTN bears some resemblance to non-orthogonal transmission. ISI in FTN leads to an “effective” convolutional code which operates in complex domain. Its effective “polynomials” are determined by the waveform, modulation, etc. Such effective convolutional code has certain error correction capability, thus reducing the reliance on the outer channel codes.

Symbol level spreading can be used for non-orthogonal multiple access [45] so that the network can accommodate massive number of users simultaneously. The spreading can be entirely linear, e.g., spreading followed by modulation, or joint spreading and modulation where the coded bits are mapped to the modulation constellation points directly [46]. Less advanced receivers can be used for linear spreading, for instance, minimum-mean squared error hard interference cancellation (MMSE-hard IC) where the decoder can be hard-output. In general, the cross-correlation between spreading sequences should be low in order to suppress cross-user interference. However, the lower the cross interference, the less number of sequences is in the pool, which would increase the collision probability if spreading sequences are randomly selected. Various types of spreading sequences have been proposed [47]. For joint spreading and modulation, its typical receiver requires soft-output decoder to carry out outer iteration, as well as the inner iterations inside the multi-user detector. Its receiver complexity is in general noticeably higher than that of MMSE-hard IC, although its performance may potentially be better.

- **Waveform**

Since 4G, orthogonal-frequency division multiplexing (OFDM) becomes the prevailing waveform for mobile communication, even though it has shortcoming such as high peak to average power ratio (PAPR). Its popularity comes from: 1) simple transmit and receiver processing, to facilitate the wide use of multiple-input-multiple-output (MIMO); 2) orthogonality between sub-carriers, thus increasing the resource utilization. To alleviate the PAPR issue, DFT-s-OFDM was used in 4G and 5G to ensure

the orthogonality between different users, while maintaining the single-carrier property of each user's signal, e.g., modulation symbols of each user may suffer inter-symbol interference due to the channel delay spreading, etc. Some variants of OFDM and DFT-s-OFDM were proposed, to reduce the out-of-band emission and make signals of each user more localized in time and frequency domain. However in 5G, all those variants became the implementation – transparent to the air interface specifications. For very high frequencies such as Terahertz, signal digitization may become very challenging, Analog processing may find more use where completely new waveform would be needed to make the circuit/processor feasible.

## 4.2 Visible light communications

Due to the ubiquitous LED lighting and higher than 80% penetration of lighting market, visible light communication (VLC) based on LED has been extensively studied during the 5G research cycle. However, due to inherent drawbacks, VLC has not been introduced to the 5G standard. With the in-depth investigations of next-generation lighting technologies, laser diode (LD)-phosphor conversion lighting technology with higher brightness, higher efficiency and farther illumination range than traditional LEDs is expected to be the most promising next-generation lighting technology [48] .

It is well known that the LD can be modulated very quickly and has higher modulated bandwidth than LED. LD-based VLC system has been demonstrated at 28.8Gbps [49] , and can potentially reach 100Gbps, which is more suitable to ultra-high data density (uHDD) services in 6G. Thus, an enhanced VLC (eVLC) based on LD lighting technologies is proposed for 6G. Moreover, the advantages of LD illumination combined with adaptive glare-free systems can facilitate high resolution, adaptive, programmable and pixelated lighting system, which can basically be realized by using a spatial light modulator such as LCoS, DLP or MEMS mirrors. These features will benefit to uHDD spatial multiplexing, such as beam division multiple access (BDMA), pixelated spatial multiplexing (PSM) and image division multiple access (IDMA).

On the other hand, the beam angle of the LD will be 1/5 to 1/10 of the beam angle of an LED with similar lumen output. The small spot of the light allows the LD-based illuminator to produce sharp edges in the output, which is about 10 times sharper than LED illumination. In addition, the very high directivity of the LD lighting will support longer distance transmission between the poles compared to LED streetlights. These features may be important in some applications that are intended to illuminate only certain areas, such as outdoor applications and integrated access and backhaul (IAB).

If using high efficient fiber, the blue light transmittance per meter is 99.8%, so the blue light loss is very small in most lighting applications with LD-phosphor splitting and phosphor remoting. In streetlight applications, electronics and LDs can be in the road side unit (RSU) for easy maintenance, while phosphors can be placed in sealed packages on the top of the pole. In the case of enhanced VLC, flexible splits of LDs and phosphor components can realize convergence of fiber lighting and distributed VLC lattice for wireless data center, resulting in a scalable, resilient and sustainable data

center network (DCN) design.

In smart car applications, LD headlights offer the advantages of high luminance and compact size. As mention above, combining LD headlights with MEMS scanning mirror technology will be the key to enable new adaptive illumination functionality with high pixel resolution. A new concept of eVLC-based V2X is presented that allows to dynamically shaping the basic intensity distribution of an adaptive LD-phosphor headlight. Fig. 7 (a) shows the V2X and V2V communications based on eVLC. In uplinks, LD headlights communicate with RSU, in which eVLC receivers and LDs are embedded. In downlinks, street lamps are wirelessly connected to the eVLC receivers on top of the cars. Meanwhile, street lamps can be used to establish backhaul links each other by free-space coherent optical communications. The eVLC-based IAB streetlamp concept is shown in Fig. 7 (b), in which blue laser fiber input from LDs in RSU is divided a little part for optical integrated coherent transceiver (ICT/ICR) of backhaul link.

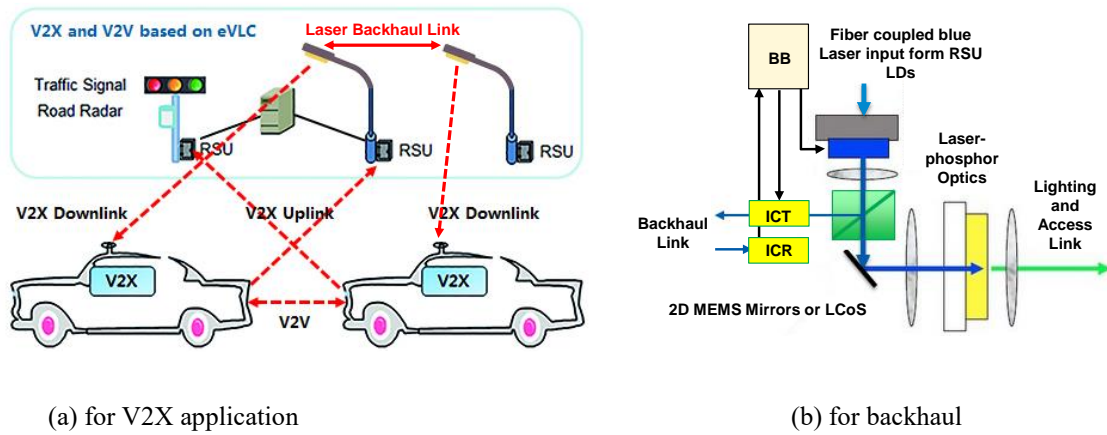

Figure 7 Two use cases for enhanced visible light communication

### 4.3 Advanced duplex

In a practical network, one typical situation is the imbalance of spectrum demand, between different networks, between different nodes in the same network, between the transceiver links of the same node, and so on. These imbalances lead to the low utilization of spectrum. Advanced duplex is expected to solve this issue. There are two potential candidate technologies: (1) spectrum sharing based (i.e. Free-Spectrum-Sharing), mainly used to solve the imbalanced spectrum requirements between different networks; (2) full degree of freedom duplex (i.e. Free-Duplex),

- **Free-Spectrum-Sharing**

At present, cellular networks mainly operate in licensed carriers. The owner of spectrum resources has exclusive right to access the spectrum. Even if the spectrum resources are temporarily idle, other others cannot use them. Such exclusive use of spectrum imposes strict restrictions and requirements on users. The reason why spectrum sharing technology has not been fully deployed is mainly due to the

constraints of spectrum regulations, but more importantly, the lack of the maturity of spectrum sharing technology itself. Significant breakthroughs in the research of spectrum sharing technology are needed, including efficient spectrum sharing technology and efficient spectrum monitoring technology, to improve the utilization of spectrum resources in the future network by using shared spectrum with full freedom, and to monitor the spectrum usage more conveniently. In 5G networks, AI will be adopted to improve effectiveness of spectrum management. It is expected that the further 6G networks will be an AI-assisted autonomous system where the network resource including the spectrum can be used and managed more dynamically and efficiently. The combination of AI and the traditional spectrum sharing technologies can be used to facilitate intelligent spectrum sharing with full freedom [50][51][52], i.e. Free-Spectrum-Sharing.

- **Free-Duplex**

As mentioned above, because the arrival of data packets often obeys Poisson distribution, the resource utilization of transceiver links (generally referred to as uplink and downlink) in real networks fluctuates dynamically and is extremely unbalanced. Enhancing the existing duplex technology is to achieve flexible spectrum allocation between transceiver links (or flexible spectrum sharing between transceiver links), so as to increase the utilization of spectrum resources from the duplex dimension.

At present, compared with the traditional mobile communication systems, 5G system is based on flexible empty port concept design, while duplex mode adopts dynamic TDD architecture, in which FDD mode is only a special case of configuration. In addition, 5G and B5G/6G are mainly available in the frequency band above 2 GHz, most of which are TDD spectrum. The CLI-RIM WID (Cross Link Interference-Remote Interference Management Work Item Description) standard project to solve downlink/uplink (DL/UL) cross-link interference will be completed in 2019 and will be included in 5G NR Rel-16 Standard Version [53]. In this standard, two kinds of interference suppression are introduced: the mechanism to solve the problem of cross-link interference between adjacent base stations and the mechanism to solve the problem of cross-link interference between remote base stations (cross-link interference caused by atmospheric waveguide phenomenon). Once these two types of interference are well addressed, 5G will be able to support the commercial deployment of Flexible Duplex features and gradually get rid of the resource utilization constraints of Fixed Duplex (FDD/TDD). Although the initial technical discussion of 5G involves full-duplex technology, it has not been adopted in 5G because of its immature theoretical and technical research.

With the progress of duplex technology and the maturity of duplex technology in the next decade, it is expected that the duplex mode in 6G era will operate in the true Free Duplex mode. That is to say, there is no FDD/TDD differentiation anymore, but a flexible and self-adaptive scheduling mode of flexible duplex or Full-Duplex, according to the service requirements between transceiver and transceiver links. Thus, the limitation of spectrum resource utilization between transceiver and transceiver links by duplex mechanism is thoroughly broken. Free Duplex mode can achieve more

efficient utilization of spectrum resources by sharing all-degree-of-freedom (time, frequency and space) spectrum resources between transceiver and receiver links (or DL and UL), so as to improve throughput and reduce transmission delay. To achieve Free Duplex mode, the key technical challenge is to break through full-duplex technology. Figure 8 depicts the evolution of duplex mode.



**Figure 8 Duplex evolution route of wireless mobile communication system**

Based on the technical characteristics of self-interference limitation, full-duplex technology is mainly suitable for the following typical application scenarios: (1) low transmission power scenarios, including short-range wireless links (e.g. D2D (Device to Device), V2X (Vehicle to Everything) and small cell with low transmission power. (2) scenarios equipped transceiver devices without strict constraint in complexity and cost, such as wireless relay and wireless backhaul; (3) scenarios with narrow beams and more spatial freedom, including communication scenarios using Massive MIMO in the frequency bands of below 6 GHz and high-frequency bands of millimeter/terahertz.

In the process of commercialization of full-duplex technology, the problems and technical challenges to be solved include suppression of high power dynamic self-interference signal, miniaturization of self-interference suppression circuit in multi-antenna RF domain, new network architecture and interference elimination mechanism under full-duplex system, coexistence and evolution strategy with FDD/TDD. In addition, from the perspective of engineering deployment, it is a more important topic to study full-duplex networking technology.

## 5 Conclusion

In this paper, we first briefly discussed the conceptions of 6G, and then focused on the potential key technologies of 6G which include four revolutionary technologies of exploratory nature and three more matured technologies. The revolutionary technologies discussed would fundamentally change the physical layer of mobile communication systems compared to 5G. Many aspects are still at the stage of scientific exploration. Yet, they indeed represent the level of science & technology development of a country in cutting-edge strategic areas. Regarding the matured technologies, extensive study and development at the physical layer are still needed to make them feasible in engineering..

The 6G network will eventually provide terabit rate per second, support an average of 1000+ wireless nodes per person in 10 years (2030~), and provide instant holographic connectivity anytime and anywhere. The future will be a fully data-driven society in which people and things are connected universally, almost instantaneously (milliseconds).

## References

- [1] International Telecommunications Union (ITU), "Focus group on technologies for Network 2030," 2019. Available: <https://www.itu.int/en/IUT-T/focusgroups/net2030/>
- [2] A. Pouttu, "6Genesis-Taking the first steps towards 6G," in *Proc. IEEE Conf. Standards Communications and Networking*, 2018. Available: [cscn2018.ieee-cscn.org/files/2018/AriPouttu.pdf](https://cscn2018.ieee-cscn.org/files/2018/AriPouttu.pdf).
- [3] Rosenworcel, "Talks up to 6G", Sept. 14, 2018 <https://www.multichannel.com/news/fccs-rosenworcel-talks-up-6g>, .
- [4] W. Miao, "We are studying 6G," March, 2018, <http://www.srrc.org.cn/article20461.aspx>,
- [5] Y. Zhao, G. Yu, and H. Xu, "6G mobile communication network: vision, challenges and key technologies," (in Chinese) *Sci. Sin. Inform.* <http://engine.scichina.com/doi/10.1360/N112019-00033>
- [6] B. Zong, et. al, "6G technologies," *IEEE Veh. Tech. Mag.*, vol. 14, no. 3, Sept., 2019, pp. 18-27.
- [7] E. C. Strinati, et. al. "6G: The next frontier. ArXiv Preprint: 1901.03239.
- [8] W. Saad, M. Bennis, M. A. Chen, "Vision of 6G wireless systems: applications, trends, technologies, and open research problems [J], arXiv:1902.10265v2 [cs.IT].
- [9] K. David and H. Berndt, "6G vision and requirements," *IEEE Veh. Tech. Mag.*, vol. 13, no. 3, Sept., 2018, pp. 72-80.
- [10] B. Zong, X. Zhao, J. Wang, X. Liu, S. Zhang, "Photonics defined radio: A new paradigm for future mobile communication of B5G/6G," in *Proc. 6th Int. Conf., Photonics, Optics and Laser Technology*, 2018.
- [11] A. Forenza, S. Perlman, F. Saibi, et. al, "Achieving Large Multiplexing Gain in Distributed Antenna Systems via Cooperation with pCell Technology," *IEEE Asilomar Conference on Signals, Systems, and Computers*, Nov.8-11, 2015.
- [12] J. Murakowski, G. J. Schneider, et. al, "Photonic probing of radio waves for k-space tomography," *Optics Express*, Vol. 25, No. 14, Jul 2017.
- [13] Z. W. Barber, C. Harrington, R. K. Mohan, et. al, "Spatial-spectral holographic real-time correlative optical processor with >100 Gb/s throughput," *Applied Optics* Vol. 56, Issue 19, pp. 5398-5406 (2017).
- [14] M. R. Konkol, D. D. Ross, S. Shi, C. E. Harrity, A. A. Wright, C. A. Schuetz, and D. W. Prather, "High-power photodiode-integrated-connected array antenna," *Journal of Lightwave Technology*, Vol.35, No.10, pp.200-2016, May, 2017.
- [15] S Ghafoor, N Boujnah, M Husain R, A Davy. MAC Protocols for Terahertz communication: A comprehensive survey, arXiv:1904.11441v1 [cs.NI].
- [16] V. Petrov, A. Pyattaev, D. Moltchanov and Y. Koucheryavy, Terahertz band communications: Applications, research challenges, and standardization activities, 2016 8th International Congress on Ultra Modern Telecommunications and Control Systems and Workshops (ICUMT), Lisbon, 2016, pp. 183-190.
- [17] J. Wells, "Faster than fiber: the future of multi-G/s wireless," *IEEE Microw. Mag.*, 2009, 10: 104-112.
- [18] T. Nagatsuma, G. Ducournan, C. C. Renaud, Advances in terahertz communications accelerated by photonics, *Journal Nature Photonics*, 2016, 10(6): 371-379.



- [19] M. Mittendorff, S. Li, T. E. Murphy, "Graphene-based waveguide-integrated terahertz modulator," *Journal ACS Photonics*, 2017, 4(2): 316-321.
- [20] J. M. Jornet, and I. F. Akyildiz, "Graphene-based plasmonic nano-antenna for terahertz band communication in nanonetworks," *IEEE Journal on Sel. Areas in Comm.*, vol. 31, December 2013, pp. 685-694.
- [21] M. Ali, Perez-Escudero, Jose Manuel, et. al, "300 GHz optoelectronic transmitter combining integrated photonics and electronics multipliers for wireless communication," *Journal of Photonics*, 2019, 6(2).
- [22] T. Kurner, "Turning THz communications into reality: status on technology: standardization and regulation," 2018 43<sup>rd</sup> Intl. Conf. on Infrared, millimeter, and terahertz waves (IRMMW-THz), Nagoya, 2018, pp. 1-3.
- [23] M. Di-Renzo, M. Debbah, D. T. Phan-Huy, et. al, "Smart radio environments empowered by AI reconfigurable meta-surfaces: an idea whose time has come," *EURASIP Journal on Wireless Commun. & Networking*, 2019.
- [24] S. Hu, F. Rusek, and O. Edfors, "Beyond massive MIMO: the potential of data transmission with large intelligent surfaces," *IEEE Trans. on Signal Processing*, vol. 66, no. 10, May 2018, pp. 2746-2758.
- [25] N. Ourrat-Ul-Ain, K Abba, C. Anas, et al, "Asymptotic analysis of large intelligent surface assisted MIMO communication, arXiv: 1903.08127v2, [cs. IT], 27, April 2019.
- [26] S. Hu, R. Rusek, and O. Edfors, "The potential of using large antenna arrays on intelligent surfaces," *IEEE 85<sup>th</sup> Veh. Tech. Conf., (VTC Spring)*, 2017, pp. 1-6.
- [27] K. Ntontin, M. Di Renzo, J. Song, et al, "Reconfigurable intelligent surfaces vs. relaying: differences, similarities and performance comparison, arXiv: 1908.08747v1 [eess. SP], 23 Aug 2019.
- [28] C Liaskos, S. Nie, A. Tsioliariidou, A. Pitsillides, S. Ioannidis, and I. Akyildiz, "A new wireless communication paradigm through software-controlled metasurfaces," *IEEE Comm. Mag.*, vol. 56, no. 9, Sept. 2018, pp. 162-169.
- [29] A. Taha, M. Alrabeiah, A. Alkhateeb, "Enabling large intelligent surfaces with compressive sensing and deep learning, [J], 2019.
- [30] B. Third'e, H. Tehn, J. et. al, "Utilization of photon orbital angular momentum in the low-frequency radio domain," *Phys. Rev. Letter.*, vol. 99, no. 8, August 2007, pp. 087701-1 – 087701-4.
- [31] S. Zheng, et. al, "Plane spiral orbital angular momentum electromagnetic wave," *IEEE Asia-Pacific Microwave Conference (APMC)*, Nanjing, China., 2015.
- [32] D. Lee, H. Sasaki, H. Fukumoto, Y. Yagi, T. Kabo, T. Shimizu, "An experiment of 100 Gbps wireless transmission using OAM-MIMO multiplexing in 28 GHz," *IEICE, SmartCom*, October 2018.
- [33] Y. Ren, et. al, "Line-of-sight millimeter-wave communications using orbital angular momentum multiplexing combined with conventional spatial multiplexing," *IEEE Trans. Wireless Comm.*, Vol. 16, no. 5, May 2017, pp.3151-3161.
- [34] A. M. Yao, and M. J. Padgett, "Orbital angular momentum origins, behavior and applications," *Adv. Opt. Photon*, 3, 161-204, 2011.
- [35] C. Zhang, and M. A Lu, "Detecting the orbital angular momentum of electro-magnetic waves using virtual rotational antenna," *Scientific Reports*, Nature Publication Group, July 2017.

- [36] O. Edfors, and A. J. Johansson, "Is orbital angular momentum (OAM) based radio communication on unexploited area," *IEEE Trans. Ant. Propagation*, 60, 1126-1131 (2012)
- [37] M. Oldoni et al., "Space-division demultiplexing in orbital-angular momentum based MIMO systems," *IEEE Trans., Ant. Propagation*, 63, 4582-4583, 2015
- [38] X. Hui, S. Zheng, Y. Cen, et. al, "Multiplexed millimeter wave communication with dual orbital angular momentum (OAM) mode antennas," *Scientific Reports*, 2015, 5: 10148.
- [39] R. Niemiec, C. Brousseau, et. al, "Characterization of an OAM antenna using a flat phase plate in the millimeter frequency band," *IEEE European Conference on Antennas & Propagation*, 2014.
- [40] Y. Zhang, et. al, "Construction of rate-compatible raptor-like quasi-cyclic LDPC code with edge classification for IDMA based random access," *IEEE Access*, Feb. 2019.
- [41] M.C. Davey, "Low-density parity check codes over GF(q)," *IEEE Communications Letters*, Vol. 2, Issue: 6, June 1998, pp. 165-167.
- [42] N. Sommer, "Low-Density Lattice Codes," *IEEE Trans. on Information Theory*, 2008, 54 (4), pp. 1561-1585.
- [43] J. Perry, "Spinal codes," *Acm Sigcomm Conference on Applications*, 2012, pp. 49-60.
- [44] Rusek F. Partial response and faster-than-nyquist signaling[M]. Department of Electrical and Information Technology, Lund University, 2007
- [45] 3GPP TR 38.812 Study on non-orthogonal multiple access (NOMA) for NR.
- [46] K. Meng et. al., "Low complexity receiver for uplink SCMA system via expectation propagation," *Proc. IEEE WCNC 2017*.
- [47] Y. Yuan, "5G non-orthogonal multiple access study," *IEEE Wireless Communications*, October 2018, pp. 6-8.
- [48] N. Trivellin, M. Yushchenko, M. Buffolo, C. De Santi, M. Meneghini, G. Meneghesso, E. Zanoni, "Laser-Based Lighting: Experimental Analysis and Perspectives", *Materials*; 10(10), 2017
- [49] C-T Tsai, C-H Cheng, H-C Kuo, G-R Lin, "Toward high-speed visible laser lighting based optical wireless communications", *Progress in Quantum Electronics*, Volume 67, September 2019.
- [50] K. Cohen, A. Nedic, R. Srikant, "Distributed learning algorithms for spectrum sharing in spatial random access networks," *Intl. Sym. on Modeling & Optimization in Mobile, Adhoc & Wireless Networks*, 2015.
- [51] S. Bhattarai, J. M. Park, B. Gao, et. al, "An overview of dynamic spectrum sharing: ongoing initiatives, challenges, and a roadmap for future research," *IEEE Trans. on Cognitive Comm. & Networking*, vol. 2, no. 2, 2017, pp. 110-128.
- [52] S. Romero and G. Leus, "Wideband spectrum sensing from compressed measurements using spectral prior information," *IEEE Trans. Signal Process.*, vol. 61, no. 24, Dec. 2013, pp. 6232-6246.
- [53] 3GPP, RP-182864, Revised WID on cross link interference (CLI) handling and remote interference management (RIM) for NR, LG Electronics, RAN#82, Sorrento, Italy, Dec 2018.