

ARCSnake: An Archimedes' Screw-Propelled, Reconfigurable Robot Snake for Complex Environments

Dimitri A. Schreiber^{†,1} *Student Member, IEEE*, Florian Richter^{†,1} *Student Member, IEEE*,
 Andrew Bilan^{‡,2}, Peter V. Gavrilo^{‡,2}, Lam Hoi Man^{‡,2}, Casey H. Price^{‡,3},
 Kalind C. Carpenter⁴, and Michael C. Yip¹ *Member, IEEE*

Abstract—This paper presents the design and performance of a screw-propelled redundant serpentine robot. This robot comprises serially linked, identical modules, each incorporating an Archimedes' screw for propulsion and a universal joint (U-Joint) for orientation control. When serially chained, these modules form a versatile snake robot platform which enables the robot to reshape its body configuration for varying environments and gait patterns that would be typical of snake movement. Furthermore, the Archimedes' screws allow for novel omni-wheel drive-like motions by speed controlling their screw threads. This paper considers the mechanical and electrical design, as well as the software architecture for realizing a fully integrated system. The system includes $3N$ actuators for N segments, each controlled using a BeagleBone Black with a customized power-electronics cape, a 9 Degrees of Freedom (DoF) Inertial Measurement Unit (IMU), and a scalable communication channel over ROS. The intended application for this robot is its use as an instrumentation mobility platform on terrestrial planets where the terrain may involve vents, caves, ice, and rocky surfaces. Additional experiments are shown on our website*.

I. INTRODUCTION

Snake-inspired robots are multi-segmented hyper-redundant robots comprised of repeated joint-segment units. They are kinematically flexible and low profile, which allows them to conform to their environment and enter confined terrain. Therefore, they can explore environments which preclude traditional robotic systems. Snake-inspired robots can be classified into two main categories [1]: *serpentine* and *snakelike* robots. Serpentine robots propel themselves using active skins, and their joints are either passive or actively controlled to better position the links for more optimal grip. In contrast, snakelike robots have passive skins and active joints to propel themselves.

In this paper, we examine the design of a novel serpentine robot which we call ARCSnake, focusing on our application of the Archimedes' screw as an active skin for terrestrial



Fig. 1: ARCSnake in a joint up configuration. This gait allows for the camera at the head to observe the surrounding environment.

propulsion. Mechanically, each segment is composed of a powered 2 Degrees of Freedom (DoF) universal joint (U-Joint) and an Archimedes' Screw. This spherical joint rotation with high torque output enables flexible placement of the Archimedes' screw. Therefore, it allows reconfigurable drive patterns that transition from omni-wheel drive, to tunneling, to snakelike undulation. Furthermore, careful implementation of robust software and electrical architectures reinforce the robot's exploration capabilities in unknown environments and will enable tether-free operation in the future.

II. RELATED WORK

Designs for snake robots have been considered for decades [2], and have followed trends in the development of motor technology for shaping its body. We discuss recent examples below. In particular, their gait's with respect to serpentine or snake-like behaviors, and considerations of their mechanical and software design for adaptability to complex and varied environments.

In general, using body conformation for locomotion is less efficient for traveling, but has inherent advantages in controlling body configuration with respect to rough or

^{†,‡}Equal contribution

¹Department of Electrical and Computer Engineering, University of California San Diego, La Jolla, CA 92093 USA. {dschreib, frichter, mlyip}@ucsd.edu

²Department of Mechanical and Aerospace Engineering, University of California San Diego, La Jolla, CA 92093 USA. {abilan, pgavrilo, hml024}@ucsd.edu

³Department of Computer Science and Engineering, University of California San Diego, La Jolla, CA 92093 USA. c2price@ucsd.edu

⁴NASA Jet Propulsion Laboratory, Pasadena, CA 91109 USA kalind.c.carpenter@jpl.nasa.gov

*Website: <https://www.sites.google.com/ucsd.edu/arcsnake>

TABLE I: ARCSnake Design Specifications

Specifications	Within	Values
Power	Module	12-60V, 310W (max)
	System	12-60V, 1240W (max)
Communication	Module	I2C
	System	TCP/IP via ROS
Sensors	Body	Optical Encoder
		Motor Current
	U-Joint	9 DoF IMU
		Temperature Sensor
Actuators	Screw	Torque: 1.6Nm continuous, 2.0Nm peak
	U-Joint	Torque: 2.1Nm continuous, 2.7Nm peak
Dimensions	Body	Max Len: 19.6cm Max Dia: 12.5cm
	U-Joint	Max Len: 16.8cm Max Dia: 11.0cm
	System	Max Len: 128.7cm Max Dia: 12.5cm
Mass	Module	Body: 1.0kg, U-Joint: 0.88kg
	Head	0.68kg
	System	6.1kg

climbing terrain. The Unified Snake [3] and its successor the SEA Snake [4] comprise repeated perpendicularly offset joints, and each link involves a custom series elastic actuator, which incorporates both onboard control and scalable interfacing. The series elasticity allows safer conformation to its environment and force control capabilities as required for perching and climbing. Yet, offset joints make control a challenge, as maintaining a continuous line of contact with the ground or climbing surface is mechanically and kinematically non-trivial.

The Amphibot [5] [6] undulates on the water’s surface by yawing its joints to form a sinusoidal wave pattern. Its passive wheels allow it to replicate the swimming motion on land, but only on planar surfaces, limiting its locomotive capabilities to only structured and flat environments. The ACM-R5 [7] amphibious snakelike robot utilizes 2-axis geared U-Joints protected by bellows. These joints have a 90 degree range of motion on both axes. ACM-R5’s segments are lined with passive wheels and fins, which provide anisotropic resistance on both land and water for propulsion. Perambulator [8] branches off from the ACM-R5’s design, implementing a 3-axis geared U-Joint housed within the length of the segment, while also using the same wheel-fin design as the ACM-R5. The design uses a differential

drive mechanism, resulting in a roll about the central axis of the snake backbone; this leaves the robot in a singular condition when the robot is straight, which is undesirable in many situations where the robot may be required to snake its way into a tight space.

Alternatively, serpentine robots that leverage an active skin mechanic for travel can realize efficient locomotion. Examples include the OmniTread [9], which utilizes moving tracks along the length of each segment to drive along terrain. OmniTread’s active skin provides robust terrestrial movement thanks to its high profile grip. Although miniaturization of tracks and the square-like cross-section of the robot is challenging. Similarly, a toroidal skin drive was proposed which uses an active skin across the entire robot [10]. This active skin enables the robot to traverse complex spaces given its soft film-like exterior. However, the design is complex and therefore challenging to seal from particulates and fluids. The toroidal skin also provides forces tangential to the body configuration which limits the locomotion capability of the skin to only the curve of the snake’s body. At a larger scale, ACM-R8 [11] utilizes large wheels with swing-grouser grips, flexing its body using hydraulics to maintain optimal grip while climbing obstacles. All of these active skins, however, have complex mechanical designs and present complex control challenges.

The Archimedes’ screw presented in this paper aims to maneuver through complex terrestrial environments through a mixture of serpentine and snake-like motions. Screw-type active skins is a new control paradigm for serpentine robots. Prior work by [12] shows the concept in 2D, where the robot uses passive wheels organized along a screw to reduce friction and developed a front-unit-following control method. The following sections describes a complete mechanical and software architecture realizing screw-propelled, spherically jointed, snake-like and serpentine robot.

III. MECHANICAL DESIGN

Each module is composed of a self-contained 2-DoF U-Joint for positioning and an Archimedes’ screw for propulsion. The U-Joint allows for 180° rotation about each principal axis. Our system is composed of four such modules with a High Definition wireless camera attached to the head.

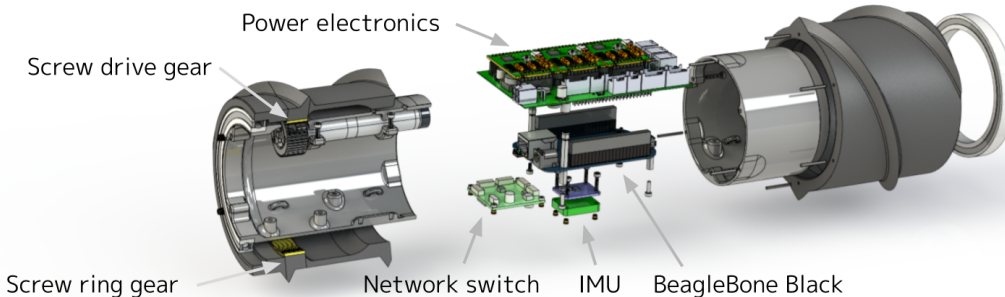

Fig. 2: An exploded view of a body from the proposed robotic serpentine design. The body uses an Archimedes’ screw as an active skin for unique locomotion capabilities while remaining mechanically simple. Inside the body is an embedded system that runs actuator controllers locally for easy scalability.

Coordinate Frame	a	α	D	θ
U-Joint Pitch	28.0	$-\frac{\pi}{2}$	0	q_p
U-Joint Yaw	0	$\frac{\pi}{2}$	0	q_y
Next Module	8.4	0	0	0

TABLE II: Kinematic model of a single module using the modified Denavit-Hartenberg parameters, where the joint angle positions are q_p and q_y for pitch and yaw respectively and the units are in centimeters and radians for distances and angles, respectively.

The kinematic model of a single module is shown in Table II using modified Denavit-Hartenberg parameters [13].

A. Archimedes' Screw Design

The Archimedes' Screw, shown in Fig. 2 provides propulsion for the robot and allows for novel gaits. A helix angle of 22° was selected as it provided the greatest drawbar pull with the least amount of slippage [14]. The optimal helix angle is affected both by the diameter of the screw and the pitch. The screw was designed to provide high maximum forces.

The two-start screw design was selected for increased soil contact. The screw has a root diameter of 112.5mm, a 22° helix angle, 2 starts, and an outer diameter of 128mm. This results in a 137mm helical pitch. A ECXSP16L motor with GPX16HP 35:1 gearhead drives this joint. This motor is capable of extremely high speeds that far exceed the gearbox's rated input speed. Therefore, the motor's speed is electrically limited to 12,000 RPM. With the integral pinioning gear (3.4:1 ratio) in the screw and the transmission inefficiencies the screw is capable of 100 RPM, 1.6Nm continuous, and 2.0Nm peak torque. This results in a 0.23 m/s screw lead speed and is an upper bound on the robot's maximum translational speed.

B. Inner Shell

The Archimedes' screw link segment is composed of an inner and outer shell. The inner shell houses the electronics and propulsion motor. The two shells are coupled through sealed thin profile bearings (VXB Part Num. 61816-2RS1) and are designed to house a 55Wh 5-cell Lithium-ion battery pack and support hermetic sealing. These extensions will be explored in future work.

C. U-Joint Design

The U-Joint, shown in Fig. 3, enables high dexterity with a large working range and minimal complexity. The joint is symmetric and composed of two identical halves, which are each driven by a Maxon ECXSP22M brushless motor with Maxon GPX22 44:1 low-backlash gearheads. This motor is capable of extremely high speeds, which far exceed the gearbox's rated input speed. Therefore, the motor's speed is electrically limited to 12,000 RPM.

The motor is coupled to the U-joint through a 6 mm width GT2 timing belt reduction (ratio 3.125:1). This timing belt offers very low backlash, high load rating, high stiffness,

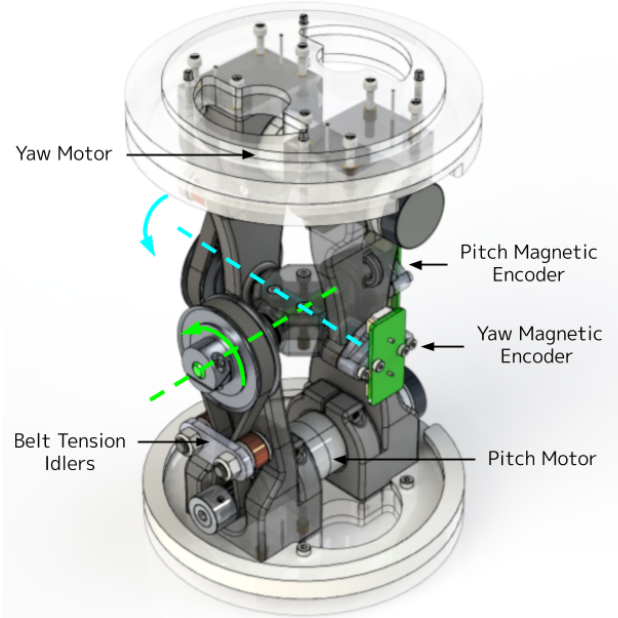

Fig. 3: A render of the U-Joint connecting bodies of the proposed serpentine robot. Timing belts with tension idlers are used for transmission because of the simple mechanical design, high load rating, and low backlash. Magnetic encoders are placed on the axis of rotation for absolute position feedback and redundant sensing.

and fair transparency. A cable drive was considered as an alternative. However, it was forgone due to the simpler design and assembly of belt drives. After gearing, the joint is capable of moving at 87 RPM. The joint's continuous output torque is 2.1Nm and peak torque is 2.7Nm after accounting for all transmission losses. The 18N preload on the timing belt provides a 1.0Nm input pulley ratcheting torque, which is higher than our transmission observes during normal operation. The joint's torque is gearbox limited and could be increased, if necessary, with an alternate gearbox.

D. Manufacturing

The robots hardware was manufactured using a combination of 3D printing, laser cutting, and machining. Markforged FDM printers were used for structural components due to their ability to print parts reinforced with continuous fiber. Formlabs Form2 SLA printers were used for complex non-structural components. Simple flat structural components, such as the Archimedes' screw to U-Joint coupling plate, were laser cut from acrylic. The U-Joint crossbars were machined and brazed from 17-4 PH Stainless Steel rods.

E. Sensors

Two AS5048B I2C 14-bit magnetic encoders are placed on the U-joint. These provide absolute sensing of the rotary axis with 0.022 degree resolution. The optical encoders on the motors provide redundant sensing to detect slipping and sensor failure.

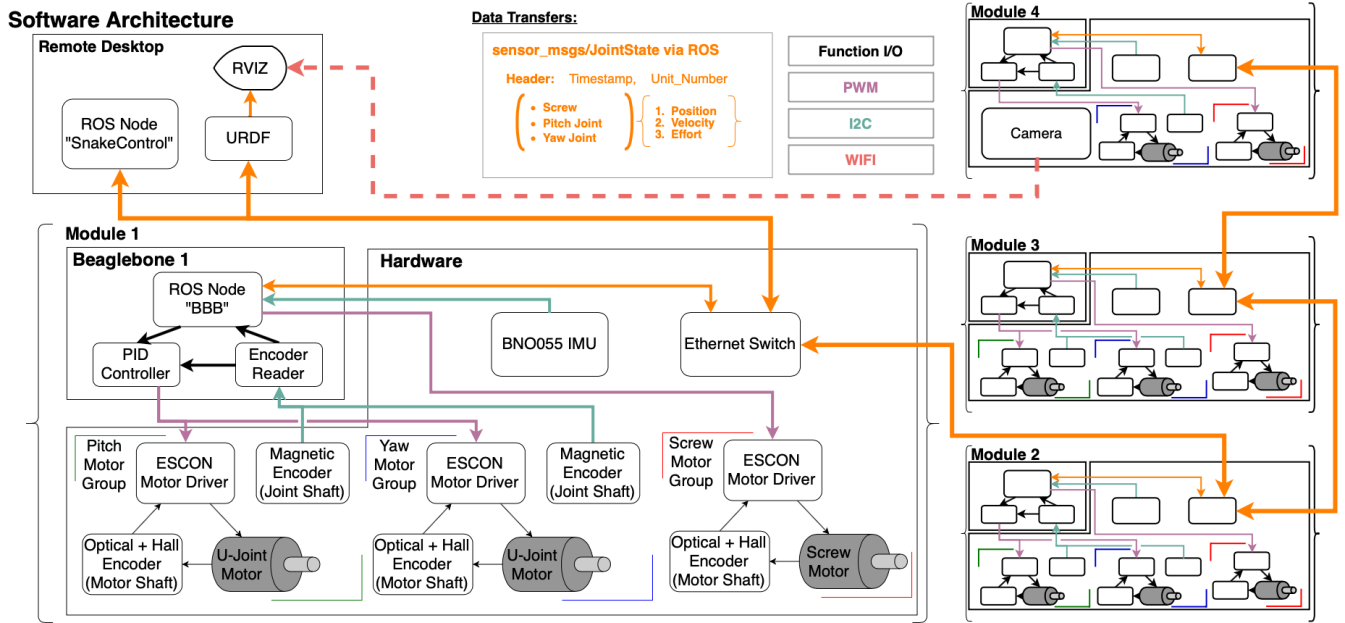

Fig. 4: Flowchart of the software architecture for the proposed serpentine robot. The embedded systems and a remote desktop communicate actuator state information with one another over TCP/IP via ROS. With this design, additional modules can be easily chained together.

A BNO055 Inertial Measurement Unit (IMU) is placed in each screw link to provide a world reference orientation. This 9 DoF System-in-Package IMU includes a 32-bit microcontroller which performs sensor fusion onboard and provides the filtered output over I2C. These are placed on separate breakouts, which are mounted distantly from motors with vibration dampening rubber.

IV. ELECTRICAL AND SOFTWARE DESIGN

Each body has its own embedded system for scalability. Due to the design's communication architecture, minimal effort is required to attach additional units. The system is robust against voltage sags and signal integrity issues from long cable runs. A flowchart of the full electrical and software system is shown in Fig. 4.

A. Electrical Design

A BeagleBone Black [15] and custom cape is in every body. Three high efficiency buck-boost regulators, VICOR PI3740-00, power each cape's 24V rail and accept input voltages from 12V to 60V. The buck-boost regulators are connected in parallel and have a maximum output current of 10.2A to 12.7A, depending on the input voltage. The 24V power rail supplies the motor drivers. A separate step-down converter, Texas Instrument's TPS54561, provides 5V power to the BeagleBone Black and a low dropout 3.3V regulator, Texas Instruments TL5209, provides power to the ancillary components.

The buck-boost regulators make the system robust against voltage sags on the power input and compatible with batteries in future iterations. Another benefit of these buck-boost regulators is their many voltage, current, and temperature

protections reduce potential failures such as back electromotive force from the motors.

Three Maxon Motor ESCON 50/5 brushless motor drivers are attached to the cape. The motors have Hall effect sensors and optical encoders, which are directly connected to their respective motor drivers. Therefore, the motor drivers have the option of closed loop torque and velocity control. Currently, all motors are set in velocity control mode and the current readings are sent via an analog signal to the BeagleBone Black. The motor drivers have multiple built in safeties, including temperature, voltage, and current protections, to ensure safe operation of the motors.

The ancillary components (magnetic encoder, IMU, and network switch) are located on separate breakouts. The magnetic encoders (AS5048B) and IMU with temperature sensor (BNO055) both communicate with the BeagleBone Black via I2C. The network switch (IP175G) connects the incoming and outgoing Ethernet to the segment and the BeagleBone Black. To improve signal integrity and for galvanic isolation when operating on batteries in future iterations, the network switch uses a transformer for decoupling.

B. Software Architecture

Each BeagleBone Black runs the Robotic Operating System (ROS) [16] interface code and the actuator control loops in two separate threads. The ROS interface code publishes the position, velocity, and effort of the actuators. Additionally, it subscribes to joint commands sent from a remote computer. The positions on the U-Joints are regulated using Proportional-Integral-Derivative (PID) controllers. These controllers run on the second thread and update the pulse-

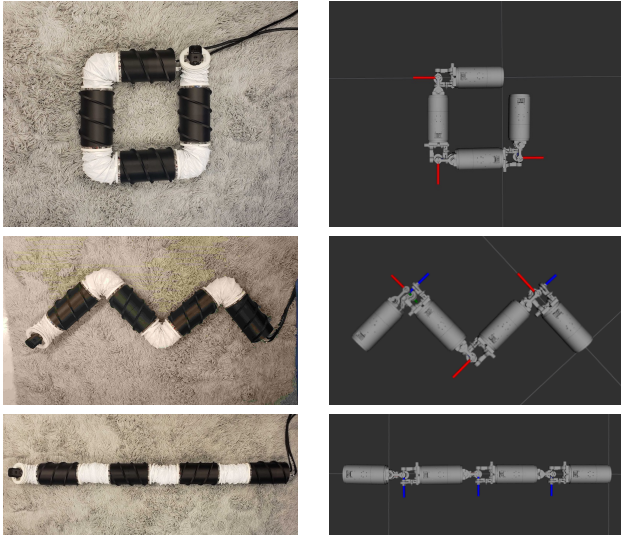

Fig. 5: Controlled and visualization of gaits on ARCSnake. These configurations show its capability to conform to different canonical body configurations resulting in different gait patterns.

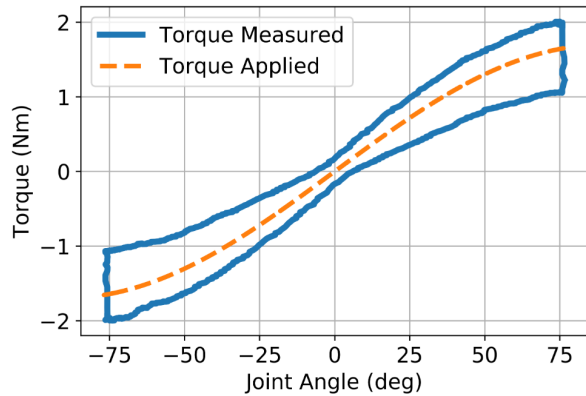

Fig. 6: Torque transparency of U-joint. Here, a cantilevered load is placed on the system as an *inverted-pendulum-like* configuration. The calculated torques are shown in dashed orange lines. The measured torque based off of motor currents in shown in the circular blue loop. Torque transparency is important for force control.

width-modulation (PWM) sent to the motor drivers. The magnetic encoder provides absolute position feedback. The ROS interface thread and controller threads run at 50Hz and 200Hz, respectively. The remote desktop uses ROS’s robot visualizer, RViz, and communicates directly to the battery powered camera, GoPro Session 4, through WiFi. The software architecture also allows for complete communication over WiFi in future iterations by simply removing the network switch and adding a WiFi dongle to the BeagleBone Blacks.

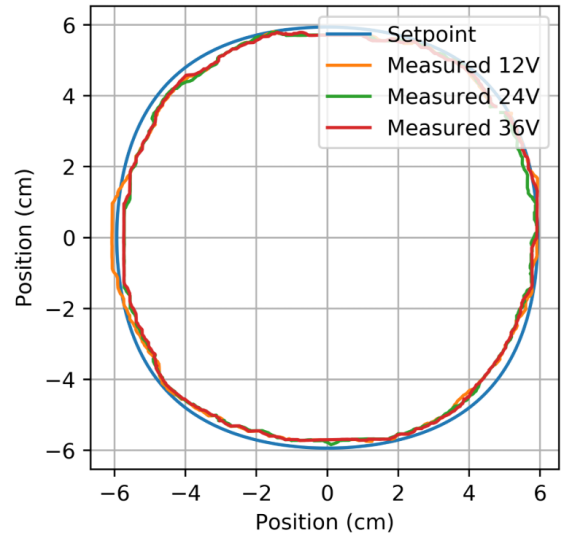

Fig. 7: A module is placed in an inverted pendulum configuration. The U-Joint regulates the body position to a planar circular trajectory. The experiment is repeated while varying the voltage inputs into the cape. This demonstrates the system’s robustness to changing input voltages.

V. EXPERIMENT AND RESULTS

Several experiments were conducted to show the proposed serpentine robot’s efficiency and abilities.

A. Gait Evaluation

Three separate gaits (straight, square, and m-shaped) were performed. During this test, the U-Joints are regulated to predefined setpoint positions, then the screw motors are regulated at predefined velocities. The gaits are shown in Fig. 5.

B. Torque Transparency

Joint torque sensing is necessary for active force control. Here passive sensing of joints is performed by measuring the motor current. This transmission’s transparency is primarily limited by friction, damping, and stiction within the gearbox, as well as motor cogging torque. These effects collectively limit one’s ability to perform torque control based on motor currents.

A test, as described in Fig. 6, was performed to evaluate the U-Joint’s torque transparency. The test exhibited a maximum hysteresis of 0.96Nm, with a corresponding maximum torque measurement error of 0.62Nm during the change of direction. Therefore, the U-Joint is sufficiently transparent to allow contact detection and force modulation. Additional calibration can further improve the measurement accuracy.

C. Additional Experiments

A single module is placed in an inverted pendulum configuration by clamping the bottom of a U-Joint on a table. The U-Joint is then controlled to move the body in a circle where the off-angle is set to 45° . The test is repeated with

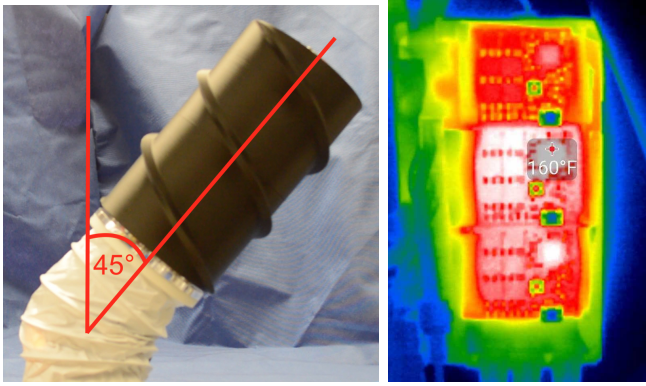

Fig. 8: From left to right the figures show a module in an inverted pendulum configuration and a thermal image of the custom cape under high load. The highest temperature recorded is 160°F.

12V, 24V, and 36V as the input to the cape. Under all three different voltage conditions, the system remains stable and regulates the body's position as seen in Fig. 7.

Separately, a BeagleBone Black with the custom cape is placed outside the module and drives two motors under heavy load. A thermal image is captured and results in a max temperature of 160°F. Images from both experiments are shown in Fig. 8.

VI. DISCUSSION AND CONCLUSION

Our adapter system with redundant sensing allows this system to serve as a platform for future explorative development. The control architecture can be changed without hardware reconfiguration. This will enable us to explore new environments and gaits. For instance, an impedance controller can be implemented by switching the motor controllers to torque mode, and due to the fairly low gear ratio of the motors combined with the transparency of the belt drives, the controller can provide a good approximation for joint torques. Since the communication is sent over the network via ROS, a remote desktop can easily be used to control the robot. This allows computation to be offloaded and integrate higher level autonomy where computation is less constrained.

Future work will involve terrestrial exploration and unknown terrain. This will likely require hermetic sealing and tether-free operation through the integration of batteries, wireless communication, and processing within the snake.

VII. ACKNOWLEDGEMENTS

This work was funded by the NASA Jet Propulsion Laboratory in Pasadena, CA under the 2018-2019 Spontaneous

Concept Award. The authors would like to thank JPL for assistance in 3D printing of parts and Spencer Chang, Pranay Mehta, and the Atkinson Hall Prototyping Lab of UCSD for help with manufacturing and assembly. D. Schreiber and F. Richter are supported via the National Science Foundation Graduate Research Fellowships.

REFERENCES

- [1] G. Granosik and J. Borenstein, "Integrated joint actuator for serpentine robots," *IEEE/ASME Transactions On Mechatronics*, vol. 10, no. 5, pp. 473–481, 2005.
- [2] S. Hirose and H. Yamada, "Snake-like robots [tutorial]," *IEEE Robotics Automation Magazine*, vol. 16, pp. 88–98, March 2009.
- [3] C. Wright, A. Buchan, B. Brown, J. Geist, M. Schwerin, D. Rollinson, M. Tesch, and H. Choset, "Design and architecture of the unified modular snake robot," in *2012 IEEE International Conference on Robotics and Automation*, pp. 4347–4354, IEEE, 2012.
- [4] D. Rollinson, Y. Bilgen, B. Brown, F. Enner, S. Ford, C. Layton, J. Rembisz, M. Schwerin, A. Willig, P. Velagapudi, *et al.*, "Design and architecture of a series elastic snake robot," in *2014 IEEE/RSJ International Conference on Intelligent Robots and Systems*, pp. 4630–4636, IEEE, 2014.
- [5] A. Crespi, A. Badertscher, A. Guignard, and A. J. Ijspeert, "Amphibot i: an amphibious snake-like robot," *Robotics and Autonomous Systems*, vol. 50, no. 4, pp. 163–175, 2005.
- [6] A. Crespi and A. J. Ijspeert, "Amphibot ii: An amphibious snake robot that crawls and swims using a central pattern generator," in *Proceedings of the 9th international conference on climbing and walking robots (CLAWAR 2006)*, no. CONF, pp. 19–27, 2006.
- [7] S. Chigisaki, M. Mori, H. Yamada, and S. Hirose, "Design and control of amphibious snake-like robot acm-r5," *Nippon Kikai Gakkai Robotikusu, Mekatoronikusu Koenkai Koen Ronbunshu (CD-ROM)*, vol. 43, 2005.
- [8] B. Li, S. Ma, C. Ye, S. Yu, Guwei Zhang, and Haili Gong, "Development of an amphibious snake-like robot," in *2010 8th World Congress on Intelligent Control and Automation*, pp. 613–618, July 2010.
- [9] J. Borenstein, M. Hansen, and A. Borrell, "The omnitread ot-4 serpentine robot design and performance," *Journal of Field Robotics*, vol. 24, no. 7, pp. 601–621, 2007.
- [10] J. C. McKenna, D. J. Anhalt, F. M. Bronson, H. B. Brown, M. Schwerin, E. Shammass, and H. Choset, "Toroidal skin drive for snake robot locomotion," in *2008 IEEE International Conference on Robotics and Automation*, pp. 1150–1155, IEEE, 2008.
- [11] H. Komura, H. Yamada, and S. Hirose, "Development of snake-like robot acm-r8 with large and mono-tread wheel," *Advanced Robotics*, vol. 29, no. 17, pp. 1081–1094, 2015.
- [12] H. Fukushima, S. Satomura, T. Kawai, M. Tanaka, T. Kamegawa, and F. Matsuno, "Modeling and control of a snake-like robot using the screw-drive mechanism," *IEEE Transactions on Robotics*, vol. 28, no. 3, pp. 541–554, 2012.
- [13] P. I. Corke, "A simple and systematic approach to assigning denavit-hartenberg parameters," *IEEE transactions on robotics*, vol. 23, no. 3, pp. 590–594, 2007.
- [14] A. M. Group and B. N. Cole, "Inquiry into amphibious screw traction," *Proceedings of the Institution of Mechanical Engineers*, vol. 175, no. 1, pp. 919–940, 1961.
- [15] "Beaglebone." <https://beagleboard.org/black>.
- [16] "Robot operation system." <https://www.ros.org/>.