

Practical Byte-Granular Memory Blacklisting using Califorms

Hiroshi Sasaki
Columbia University
sasaki@cs.columbia.edu

Miguel A. Arroyo
Columbia University
miguel@cs.columbia.edu

M. Tarek Ibn Ziad
Columbia University
mtarek@cs.columbia.edu

Koustubha Bhat[†]
Vrije Universiteit Amsterdam
k.bhat@vu.nl

Kanad Sinha
Columbia University
kanad@cs.columbia.edu

Simha Sethumadhavan
Columbia University
simha@cs.columbia.edu

Abstract

Recent rapid strides in memory safety tools and hardware have improved software quality and security. While coarse-grained memory safety has improved, achieving memory safety at the granularity of individual objects remains a challenge due to high performance overheads which can be between $\sim 1.7x$ – $2.2x$. In this paper, we present a novel idea called *Califorms*, and associated program observations, to obtain a low overhead security solution for practical, byte-granular memory safety.

The idea we build on is called memory blacklisting, which prohibits a program from accessing certain memory regions based on program semantics. State of the art hardware-supported memory blacklisting while much faster than software blacklisting creates memory fragmentation (of the order of few bytes) for each use of the blacklisted location. In this paper, we observe that metadata used for blacklisting can be stored in dead spaces in a program’s data memory and that this metadata can be integrated into microarchitecture by changing the cache line format. Using these observations, Califorms based system proposed in this paper reduces the performance overheads of memory safety to $\sim 1.02x$ – $1.16x$ while providing byte-granular protection and maintaining very low hardware overheads.

The low overhead offered by Califorms enables always on, memory safety for small and large objects alike, and the fundamental idea of storing metadata in empty spaces, and microarchitecture can be used for other security and performance applications.

1 Introduction

With recent interest in microarchitecture side channels, it is important not to lose sight of more traditional software security threats. Security is a full-system property where both software and hardware have to be secure for a system to be secure. Historically, program memory safety violations have provided a significant opportunity for exploitation: for instance, a recent report from Microsoft revealed that the root cause of more than half of all exploits were software

memory safety violations [1]. In response to the severity of this threat, improvements in software checking tools, such as AddressSanitizer [2], and advances in the form of commercial hardware support for memory safety such as Oracle’s ADI [3] and Intel’s MPX [4] have enabled programmers to detect and fix memory safety violations before deploying software.

Current software and hardware-supported solutions excel at providing coarse-grained memory safety, i.e., detecting memory access beyond arrays and `malloc`’d regions (struct and class instances). However, they are not suitable for fine-grained memory safety (i.e., detecting overflows within objects, such as fields within a struct, or members within a class) due to the high performance overheads and/or need for making intrusive changes to the source code [5]. For instance, a recent work that aims to provide intra-object overflow protection functionality incurs a $2.2x$ performance overhead [6]. These overheads are problematic because they not only reduce the number of pre-deployment tests that can be performed, but also impede post-deployment continuous monitoring, which researchers have pointed out is necessary for detecting benign and malicious memory safety violations [7]. Thus, a low overhead memory safety solution that can enable continuous monitoring and provide complete program safety has been elusive.

The source of overheads stem from how current designs store and use metadata necessary for enforcing memory safety. In Intel MPX [4], Hardbound [8], CHERI [9, 10], and PUMP [11], the metadata is stored for each pointer, and each data or code memory access through a pointer performs checks using the metadata. Since C/C++ memory accesses tend to be highly pointer based, the performance and energy overheads of accessing metadata can be significant in such systems. Furthermore, the management of metadata especially if it is stored in a disjoint manner from the pointer can also create significant engineering complexity in terms of performance and usability. This was evidenced by the fact that compilers like LLVM and GCC dropped support for Intel MPX in their mainline after an initial push to integrate into the toolchain [4].

Our approach for reducing overheads is two-fold. First, instead of checking access bounds for each pointer access, we

[†]Part of this work was carried out while the author was a visiting student at Columbia University.

blacklist all memory locations that should never be accessed. In theory, this is a strictly weaker form of security than whitelisting but we argue that in practice, blacklisting can be more practical because of its ease of deployment and low overheads. Informally, deployments apply whitelisting techniques partially to reduce overheads and be backward compatible which reduces their security, while blacklisting techniques can be applied more broadly due to their low overheads. Additionally, blacklisting techniques complement defenses in existing systems better since they do not require intrusive changes.

Our second optimization is the novel metadata storage scheme. We observe that by using dead memory spaces in the program, we can store metadata needed for memory safety for free for nearly half of the program objects. These dead spaces occur because of language alignment requirements and are inserted by the compiler. When we cannot find a naturally occurring dead space, we manually insert a dead space. The overhead due to this dead space is smaller than traditional methods for storing metadata because of how we represent the metadata: our metadata is smaller (one byte) as opposed to multiple bytes with traditional whitelisting or blacklisting memory safety techniques.

A natural question is how the dead (more commonly referred to as *padding*) bytes can be distinguished from normal bytes in memory. A straightforward scheme results in one bit of additional storage per byte to identify if a byte is a dead byte; this scheme results in a space overhead of 12.5%. We reduce this overhead to one bit per 64B cache line (0.2% overhead) without any loss of precision by only reformatting how data is stored in cache lines. Our technique, *Califorms*, uses one bit of additional storage to identify if the cache line associated with the memory contains any dead bytes. For *califormed* cache lines, i.e., lines which contain dead bytes, the actual data is stored following the “header”, which indicates the location of dead bytes, as shown in Figure 1.

With this support, it is easy to describe how a *Califorms* based system for memory safety works. The dead bytes, either naturally harvested or manually inserted, are used to indicate memory regions that should never be accessed by a program (i.e., blacklisting). If an attacker accesses these regions, we detect this rogue access without any additional metadata accesses as our metadata resides inline.

Our experimental results on the SPEC CPU2006 benchmark suite indicate that the overheads of *Califorms* are quite low: software overheads range from 2 to 14% slowdown (or alternatively, 1.02x to 1.16x performance overhead) depending on the amount and location of padding bytes used. This provides the functionality for the user/customer to tune the security according to their performance requirements. Hardware induced overheads are also negligible, on average less than 1%. All of the software transformations are performed using the LLVM compiler framework using a front-end source-to-source transformation. These overheads

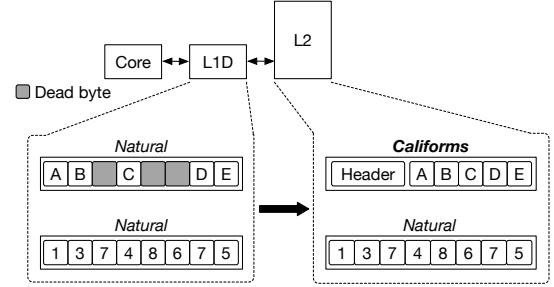

Figure 1. *Califorms* offers memory safety by detecting accesses to dead bytes in memory. Dead bytes are not stored beyond the L1 data cache and identified using a special header in the L2 cache (and beyond) resulting in very low overhead. The conversion between these formats happens when lines are filled or spilled between the L1 and L2 caches. The absence of dead bytes results in the cache lines stored in the same natural format across memory system.

are substantially lower compared to the state-of-the-art software or hardware supported schemes (viz., 2.2x performance and 1.1x memory overheads for EffectiveSan [6], and 1.7x performance and 2.1x memory overheads for Intel MPX [4]).

2 Motivation

One of the key ways in which we mitigate the overheads for fine-grained memory safety is by opportunistically harvesting padding bytes in programs to store metadata. So how often do these occur in programs? Before we answer that question let us concretely understand padding bytes with an example. Consider the struct `A` defined in Listing 1(a). Let us say the compiler inserts a three-byte padding in between `char c` and `int i` as in Listing 1(b) because of the C language requirement that integers should be padded to their natural size (which we assume to be four bytes here). These types of paddings are not limited to C/C++ but also many other languages and their runtime implementations. To obtain a quantitative estimate on the amount of paddings, we developed a compiler pass to statically collect the padding size information. Figure 3 presents the histogram of struct densities for SPEC CPU2006 C and C++ benchmarks and the V8 JavaScript engine. Struct density is defined as the sum of the size of each field divided by the total size of the struct including the padding bytes (i.e., the smaller or sparser the struct density the more padding bytes the struct has). The results reveal that 45.7% and 41.0% of structs within SPEC and V8, respectively, have at least one byte of padding. This is encouraging since even without introducing additional padding bytes (no memory overhead), we can offer protection for certain compound data types restricting the remaining attack surface.

Naturally, one might inquire about the safety for the rest of the program. To offer protection for all defined compound data types (called the full strategy), we can insert random

```

struct A {
  char c;
  int i;
  char buf[64];
  void (*fp)();
  double d;
}

struct A_opportunistic {
  char c;
  /* compiler inserts padding
   * bytes for alignment */
  char padding_bytes[3];
  int i;
  char buf[64];
  void (*fp)();
  double d;
}

struct A_full {
  /* we protect every field with
   * random security bytes */
  char security_bytes[2];
  char c;
  char security_bytes[1];
  int i;
  char security_bytes[3];
  char buf[64];
  char security_bytes[2];
  void (*fp)();
  char security_bytes[1];
  double d;
  char security_bytes[2];
}

struct A_intelligent {
  char c;
  int i;
  /* we protect boundaries
   * of arrays and pointers with
   * random security bytes */
  char security_bytes[3];
  char buf[64];
  char security_bytes[2];
  void (*fp)();
  char security_bytes[3];
  double d;
}

```

(a) Original.
(b) Opportunistic.
(c) Full.
(d) Intelligent.

Listing 1. Example of three security bytes harvesting strategies: (b) *opportunistic* uses the existing padding bytes as security bytes, (c) *full* protect every field within the struct with security bytes, and (d) *intelligent* surrounds arrays and pointers with security bytes.

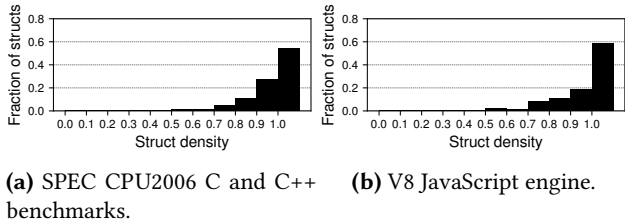

Figure 3. Struct density histogram of SPEC CPU2006 benchmarks and the V8 JavaScript engine. More than 40% of the structs have at least one padding byte.

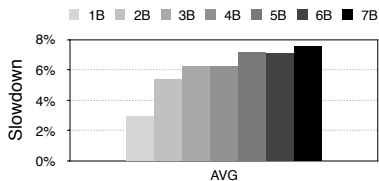

Figure 4. Average performance overhead with additional paddings (one byte to seven bytes) inserted for every field within structs (and classes) of SPEC CPU2006 C and C++ benchmarks.

sized padding bytes, also referred to as security bytes, between every field of a struct or member of a class as in Listing 1(c). Random sized security bytes are chosen to provide a probabilistic defense as fixed sized security bytes can be jumped over by an attacker once s/he identifies the actual size (and the exact memory layout). Additionally, by carefully choosing the minimum and maximum sizes for insertion, we can keep the average security byte size small (such as two or three bytes). Intuitively, the higher the unpredictability (or randomness) there is within the memory layout, the higher the security level we can offer.

While the full strategy provides the widest coverage, not all of the security bytes provide the same security utility. For example, basic data types such as char and int cannot

be easily overflowed past their bounds. The idea behind the intelligent insertion strategy is to prioritize insertion of security bytes into security-critical locations as presented in Listing 1(d). We choose data types which are most prone to abuse by an attacker via overflow type accesses: (1) arrays and (2) data and function pointers. In the example in Listing 1(d), the array buf[64] and the function pointer fp are protected with random sized security bytes. While it is possible to utilize padding bytes present between other data types without incurring memory overheads, doing so would come at an additional performance overhead.

In comparison to opportunistic harvesting, the other more secure strategies (e.g., full strategy) come at an additional performance overhead. We analyze the performance trend in order to decide how many security bytes can be reasonably inserted. For this purpose we developed an LLVM pass which pads every field of a struct with fixed size paddings. We measure the performance of SPEC CPU2006 benchmarks by varying the padding size from one byte to seven bytes. The detailed evaluation environment and methodology is described later in Section 8.

Figure 4 demonstrates the average slowdown when inserting additional bytes for harvesting. As expected, we can see the performance overheads increase as we increase the padding size, mainly due to ineffective cache usage. On average the slowdown is 3.0% for one byte and 7.6% for seven bytes of padding. The figure presents the ideal (lower bound) performance overhead when fully inserting security bytes into compound data types; the hardware and software modifications we introduce add additional overheads on top of these numbers. We strive to provide a mechanism that allows the user to tune the security level at the cost of performance and thus explore several security byte insertion strategies to reduce the performance overhead in the paper.

3 Full System Overview

The Califorms framework consists of multiple components we discuss in the following sections:

- **Architecture Support.** An ISA extension of a machine instruction called CFORM that performs califorming (i.e., (un)setting security bytes) of cache lines, and a privileged Califorms exception which is raised upon misuse of security bytes (Section 4).
- **Microarchitecture Design.** New cache line formats that enable low cost access to the metadata — we propose different Califorms for L1 cache vs. L2 cache and beyond (Section 5).
- **Software Design.** Compiler, memory allocator and operating system extensions which insert the security bytes at compile time and manages the security bytes via the CFORM instruction at runtime (Section 6).

At compile time each compound data type, a struct or a class, is examined and security bytes are added according to a user defined insertion policy viz. opportunistic, full or intelligent, by a source-to-source translation pass. When we run the binary with security bytes, when compound data type instances are created in the heap dynamically, we use a new version of malloc that issues CFORM instructions to set the security bytes after the space is allocated. When the CFORM instruction is executed, the cache line format is transformed at the L1 cache controller (assuming a cache miss) and is inserted into the L1 data cache. Upon an L1 eviction, the L1 cache controller re-califorms the cache line to meet the Califorms of the L2 cache.

While we add additional metadata storage to the caches, we refrain from doing so for main memory and persistent storage to keep the changes local within the CPU core. When a califormed cache line is evicted from the last-level cache to main memory, we keep the cache line califormed and store the additional one metadata bit into spare ECC bits similar to Oracle’s ADI [3].¹ When a page is swapped out from main memory, the page fault handler stores the metadata for all the cache lines within the page into a reserved address space managed by the operating system; the metadata is reclaimed upon swap in. Therefore, our design keeps the cache line format califormed throughout the memory hierarchy. A califormed cache line is un-califormed only when the corresponding bytes cross the boundary where the califormed data cannot be understood by the other end, such as writing to I/O (e.g., pipe, filesystem or network socket). Finally, when an object is freed, the freed bytes are califormed and zeroed for offering temporal safety.

At runtime, when a rogue load or store accesses a califormed byte the hardware returns a privileged, precise security exception to the next privilege level which can take any appropriate action including terminating the program.

¹ADI stores four bits of metadata per cache line for allocation granularity enforcement while Califorms stores one bit for sub-allocation granularity enforcement.

Table 1. K-map for the CFORM instruction. X represents “Don’t Care”.

		R2, R3		
		X, Allow	Set, Allow	Set, Allow
Initial	Regular Byte	Regular Byte	Exception	Security Byte
	Security Byte	Security Byte	Regular Byte	Exception

4 Architecture Support

4.1 CFORM Instruction

The format of the instruction is “CFORM R1, R2, R3”. The value in register R1 points to the starting (cache aligned) address in the virtual address space, denoting the start of the 64B chunk which fits in a single 64B cache line. Table 1 represents a K-map for the CFORM instruction. The value in register R2 indicates the attributes of said region represented in a bit vector format (1 to set and 0 to unset the security byte). The value in register R3 is a mask to the corresponding 64B region, where 1 allows and 0 disallows changing the state of the corresponding byte. The mask is used to perform partial updates of metadata within a cache line. We throw a privileged Califorms exception when the CFORM instruction tries to set a security byte to an existing security byte location, and unset a security byte from a normal byte.

The CFORM instruction is treated similar to a store instruction in the processor pipeline, where it first fetches the corresponding cache line into the L1 data cache upon an L1 miss (assuming a write allocate cache policy). Next, it manipulates the bits in the metadata storage to appropriately set or unset the security bytes.²

4.2 Privileged Exceptions

When the hardware detects an access violation, it throws a privileged exception once the instruction becomes non-speculative. There are some library functions which violate the aforementioned operations security bytes such as memcpy so we need a way to suppress the exceptions. In order to whitelist such functions, we manipulate the exception mask registers and let the exception handler decide whether to suppress the exception or not. Although privileged exception handling is more expensive than handling user-level exceptions (because it requires a context switch to the kernel), we stick with the former to limit the attack surface. We rely on the fact that the exception itself is a rare event and would have negligible effect on performance.

²We also investigate the possibility of using a variant of CFORM instruction which does not store the modified cache line into the L1 data cache, just like the non-temporal (or streaming) load/store instructions (e.g., MOVNTI, MOVNTQ, etc) in Section 6.1.

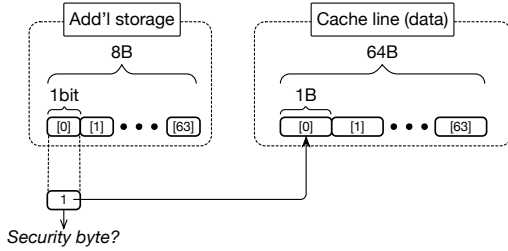

Figure 5. Califorms-bitvector: L1 Califorms implementation using a bit vector that indicates whether each byte is a security byte. HW overhead of 8B per 64B cache line.

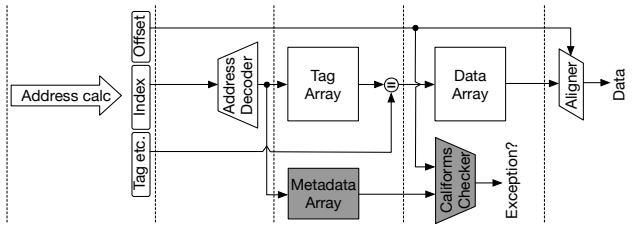

Figure 6. Pipeline diagram for the L1 cache hit operation. The shaded components correspond to Califorms.

5 Microarchitecture Design

The microarchitectural support for our technique aims to keep the common case fast: L1 cache uses the straightforward scheme of having one bit of additional storage per byte. All califormed cache lines are transformed to the straightforward scheme at the L1 data cache controller so that typical loads and stores which hit in the L1 cache do not have to perform address calculations to figure out the location of original data (which is required for Califorms of L2 cache and beyond). This design decision guarantees that for the common case the latencies will not be affected due to security functionality. Beyond the L1, the data is stored in the optimized califormed format, i.e., one bit of additional storage for the entire cache line. The transformation happens when the data is filled in or spilled from the L1 data cache (between the L1 and L2), and adds minimal latency to the L1 miss latency. For main memory, we store the additional bit per cache line size in the DRAM ECC spare bits, thus completely removing any cycle time impact on DRAM access or modifications to the DIMM architecture.

5.1 L1 Cache: Bit Vector Approach

To satisfy the L1 design goal we consider a naive (but low latency) approach which uses a bit vector to identify which bytes are security bytes in a cache line. Each bit of the bit vector corresponds to each byte of the cache line and represent its state (normal byte or security byte). Figure 5 presents a schematic view of this implementation *califorms-bitvector*. The bit vector requires a 64-bit (8B) bit vector per 64B cache line which adds 12.5% storage overhead for just the L1-D caches (comparable to ECC overhead for reliability).

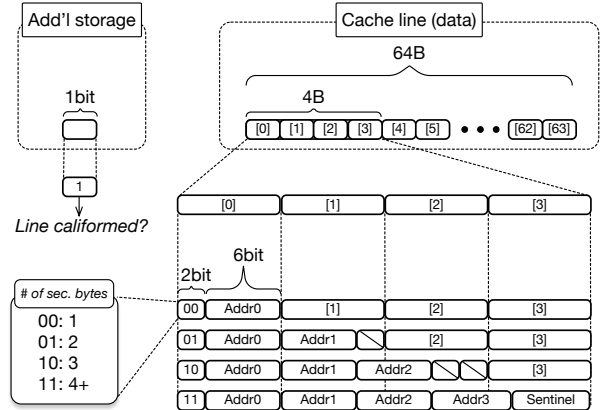

Figure 7. Califorms-sentinel that stores a bit vector in security byte locations. HW overhead of 1-bit per 64B cache line.

Figure 6 shows the L1 data cache hit path modifications for Califorms. If a load accesses a califormed byte (which is determined by reading the bit vector) an exception is recorded to be processed when the load is ready to be committed. Meanwhile, the load returns a pre-determined value for the security byte (in our design the value 0 which is the value that the memory region is initialized to upon deallocation). The reason to return the pre-determined value is to avoid a speculative side channel attack to identify security byte locations and is discussed in greater detail in Section 7. On store accesses to califormed bytes we report an exception before the store commits.

5.2 L2 Cache and Beyond: Sentinel Approach

For L2 and beyond, we take a different approach that allows us to recognize whether each byte is a security byte with fewer bits, as using the L1 metadata format throughout the system will increase the cache area overhead by 12.5%, which may not be acceptable. Figure 7 illustrates our proposed *califorms-sentinel*, which has a 1-bit or 0.2% metadata overhead per 64B cache line.

The key insight that enables these savings is the following observation: the number of addressable bytes in a cache line is less than what can be represented by a single byte (we only need six bits). For example, let us assume that there is (at least) one security byte in a 64B cache line. Considering a byte granular protection there are at most 63 unique values (bytes) that non-security bytes can have. Therefore, we are guaranteed to find a six bit pattern which is not present in any of the normal bytes' least (or most) significant six bits. We use this pattern as a sentinel value to represent the security bytes within the cache line.

If we store the six bit sentinel value as additional metadata, the overhead will be seven bits (six bits plus one bit to specify if the cache line is califormed) per cache line. Instead, we propose a new cache line format which stores the sentinel value within a security byte to reduce the metadata overhead

```

1: Read the Califorms metadata for the evicted line and OR them
2: if result is 0 then
3:   Evict the line as is and set Califorms bit to 0
4: else
5:   Set Califorms bit to 1
6:   Perform following operations on the cache line:
7:     Scan least 6-bit of every byte to determine sentinel
8:     Get locations of 1st 4 security bytes
9:     Store data of 1st 4 bytes in locations obtained in 8:
10:    Fill the 1st 4 bytes based on Figure 7
11:    Use the sentinel to mark the remaining security bytes
12: end

```

Algorithm 1. Califorms conversion from the L1 cache (califorms-bitvector) to L2 cache (califorms-sentinel).

```

1: Read the Califorms bit for the inserted line
2: if result is 0 then
3:   Set the Califorms metadata bit vector to [0]
4: else
5:   Perform following operations on the cache line:
6:     Check the least significant 2-bit of byte 0
7:     Set the metadata of byte[Addr[0-3]] to 1 based on 6:
8:     Set the metadata of byte[Addr[byte == sentinel]] to 1
9:     Set the data of byte[0-3] to byte[Addr[0-3]]
10:    Set the new locations of byte[Addr[0-3]] to zero
11: end

```

Algorithm 2. Califorms conversion from the L2 cache (califorms-sentinel) to L1 cache (califorms-bitvector).

down to one bit per cache line. The idea is to use four different formats depending on the number of security bytes in the cache line, as we explain below.

Califorms-sentinel stores the metadata into the first four bytes (at most) of the 64B cache line. Two bits of the 0th byte is used to specify the number of security bytes within the cache line: 00, 01, 10 and 11 represent one, two, three, and four or more security bytes, respectively. If there is only one security byte in the cache line, we use the remaining six bits of the 0th byte to specify the location of the security byte (and the original value of the 0th byte is stored in the security byte). Similarly when there is two or three security bytes in the cache line, we use the bits of the 1st and 2nd bytes to locate them. The key observation is that, we gain two bits per security byte since we only need six bits to specify a location in the cache line. Therefore when we have four security bytes, we can locate four addresses and have six bits remaining in the first four bytes. This remaining six bits can be used to store a sentinel value, which allows us to have any number of additional security bytes.

Although the sentinel value depends on the actual values within the 64B cache line, it works naturally with a write-allocate L1 cache, which is the most commonly used cache allocation policy in modern microprocessors. The cache line format can be converted upon L1 cache eviction and insertion (califorms-bitvector to/from califorms-sentinel), and the sentinel value only needs to be found upon L1 cache eviction. Also, it is important to note that califorms-sentinel supports critical-word first delivery since the security byte locations can be quickly retrieved by scanning only the first 4B of the first 16B flit. Algorithms 1 and 2 describe the high-level

process used for converting from L1 to L2 Califorms and vice versa.

Figure 8 shows the logic diagram for the spill module. The circled numbers refer to the corresponding steps in Algorithm 1. In the top-left corner, the Califorms metadata for the evicted line is ORed to construct the L2 cache (califorms-sentinel) metadata bit. The bottom-right square details the process of determining sentinel. We scan least 6-bit of every byte, decode them, and OR the output to construct a used-values vector. The used-values vector is then processed by a Find-index block to get the sentinel (line 7). The Find-index block takes a 64-bit input vector and searches for the index of the first zero. It is constructed using 64 shift blocks followed by a single comparator.

The top-right corner of Figure 8 shows the logic for getting the locations of the first four security bytes (line 8). It consists of four successive combinational Find-index blocks (each detecting one security byte) in our evaluated design. This logic can be easily pipelined into four stages, if needed, to completely hide the latency of the spill process in the pipeline. Finally, we store the data of the first four bytes in locations obtained from the Find-index blocks and fill the same four bytes based on Figure 7.

Figure 9 shows the logic diagram for the fill module, as summarized in Algorithm 2. The blue (==) blocks are constructed using logic comparators. The Califorms bit of the L2 inserted line is used to control the value of the L1 cache (califorms-bitvector) metadata. The first two bits of the L2 inserted line are used as inputs for the comparators to decide on the metadata bits of the first four bytes as specified in Figure 7. Only if those two bits are 11, the sentinel value is read from the fourth byte and fed, with the least 6-bits of each byte, to 60 comparators simultaneously to set the rest of the L1 metadata bits. Such parallelization reduces the latency impact of the fill process.

5.3 Load/Store Queue Modifications

Since the CFORM instruction updates the architecture state (writes values), it is functionally a store instruction and handled as such in the pipeline. However, there is a key difference: unlike a store instruction, the CFORM instruction should not forward the value to a younger load instruction whose address matches within the load/store queue (LSQ) but instead return the value zero. This functionality is required to provide tamper-resistance against side-channel attacks. Additionally, upon an address match, both load and store instructions subsequent to an in flight CFORM instruction are marked for Califorms exception (which is thrown when the instruction is committed).

In order to detect an address match in the LSQ with a CFORM instruction, first a cache line address should be matched with all the younger instructions. Subsequently upon a match, the value stored in the LSQ for the CFORM instruction, which contains the mask value indicating

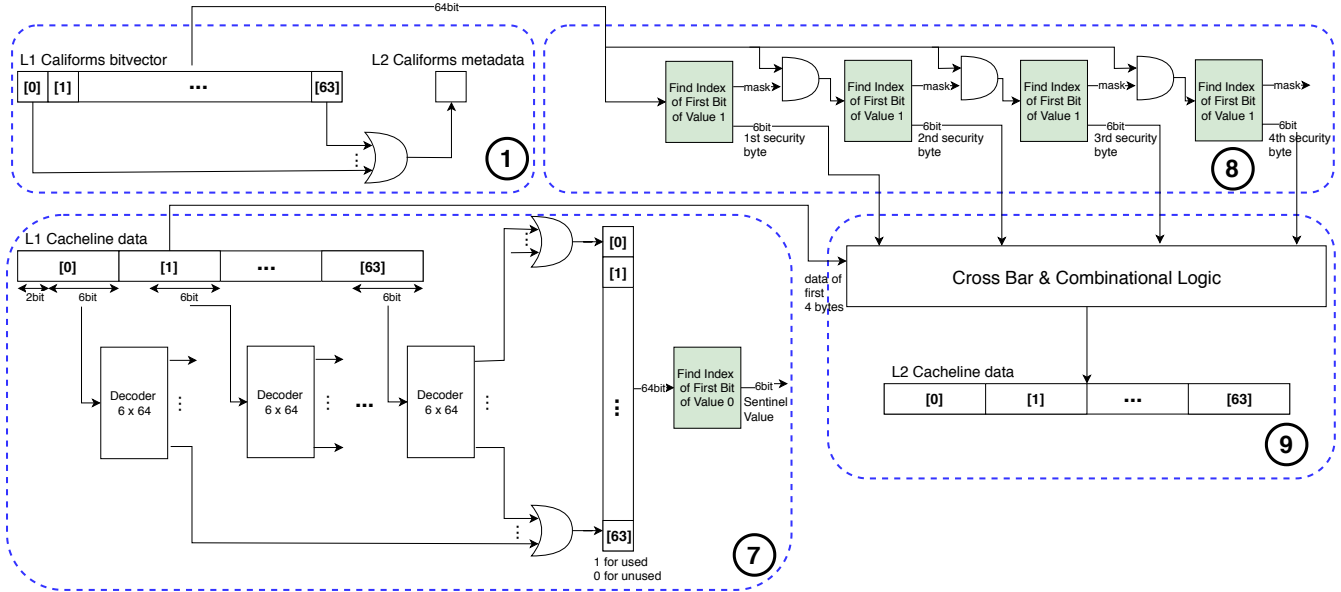

Figure 8. Logic diagram for Califorms conversion from the L1 cache (califorms-bitvector) to L2 cache (califorms-sentinel). The green Find-index blocks are constructed using 64 shift blocks followed by a single comparator. The circled numbers refer to the corresponding steps in Algorithm 1.

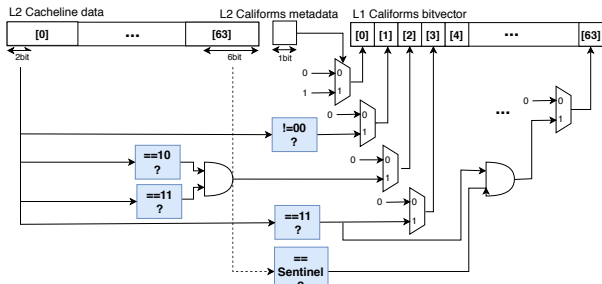

Figure 9. Logic diagram for Califorms conversion from the L2 cache (califorms-sentinel) to L1 cache (califorms-bitvector), as described in Algorithm 2. The blue (==) blocks are constructed using logic comparators.

to-be-califormed bytes, is used to confirm the final match. To facilitate a match with a CFORM instruction, each LSQ entry should be associated with a bit to indicate whether the entry contains a CFORM instruction. Detecting a complete match may take multiple cycles, however, a legitimate load/store instruction should never be forwarded a value from a CFORM instruction, and thus the store-to-load forwarding from a CFORM instruction is not on the critical path of the program (i.e., its latency should not affect the performance, and we do not evaluate its effect in our evaluation). Alternately, if LSQ modifications are to be avoided, the CFORM instructions can be surrounded by memory serializing instructions (i.e., ensure that CFORM instructions are the only in flight memory instructions).

6 Software Design

We describe compiler support, the memory allocator changes and the operating system changes to support Califorms in the following.

6.1 Dynamic Memory Management

We can consider two approaches to applying security bytes: (1) *Dirty-before-use*. Unallocated memory has no security bytes. We set security bytes upon allocation and unset them upon deallocation; or (2) *Clean-before-use*. Unallocated memory remains filled with security bytes all the time. We clear the security bytes (in legitimate data locations) upon allocation and set them upon deallocation. Ensuring temporal memory safety in the heap remains a non-trivial problem [1]. We therefore choose to follow a *clean-before-use* approach in the heap, so that deallocated memory regions remain protected by califormed security bytes³. Additionally, in order to provide temporal memory safety, we do not reallocate recently freed regions until the heap is sufficiently consumed (quarantining). Compared to the heap, the security benefits are limited for the stack since temporal attacks on the stack (e.g., use-after-return attacks) are much rarer. Hence, we apply the *dirty-before-use* scheme on the stack.

³It is natural to use the non-temporal CFORM instruction when deallocating a memory region; deallocated region is not meant to be used by the program and thus polluting the L1 data cache with those memory is harmful and should be avoided. Not evaluated in this paper is the use of non-temporal instructions which should provide better performance.

6.2 Compiler

Our compiler-based instrumentation infers where to place security bytes within target objects, based on their type layout information. The compiler pass supports three insertion policies: the first *opportunistic* policy supports security bytes insertion into existing padding bytes within the objects, and the other two support modifying object layouts to introduce randomly sized security byte spans that follow the *full* or *intelligent* strategies described in Section 2. The first policy aims at retaining interoperability with external code modules (e.g., shared libraries) by avoiding type layout modification. Where this is not a concern, the latter two policies help offer stronger security coverage — exhibiting a tradeoff between security and performance.

6.3 Operating System Support

We need the following support in the operating system:

- **Privileged Exceptions.** As the Califorms exception is privileged, the operating system needs to properly handle it as with other privileged exceptions (e.g., page faults). We also assume the faulting address is passed in an existing register so that it can be used for reporting/investigation purposes. Additionally, for the sake of usability and backwards compatibility, we have to accommodate copying operations similar in nature to `memcpy`. For example, a simple struct to struct assignment could trigger this behavior, thus leading to a potential breakdown of califormed software. Hence, in order to maintain usability, we allow whitelisting functionality to suppress the exceptions. This is done by issuing a privileged store instruction to modify the value of exception mask registers before entering and after exiting the according piece of code. We discuss the implications of this design choice in Section 7.
- **Page Swaps.** As we have discussed in Section 3, data with security bytes is stored in main memory in a califormed format. When a page with califormed data is swapped out from main memory, the page fault handler needs to store the metadata for the entire page into a reserved address space managed by the operating system; the metadata is reclaimed upon swap in. The kernel has enough address space in practice (kernel’s virtual address space is 128TB for a 64-bit Linux with 48-bit virtual address space) to store the metadata for all the processes on the system since the size of the metadata for a 4KB page consumes only 8B.

7 Security Discussion

7.1 Threat Model

For the security evaluation of this work, we assume a threat model comparable to that used in contemporary related works. We assume the victim program to have one or more vulnerabilities that an attacker can exploit to gain arbitrary read and write capabilities in the memory. Furthermore, we assume that the adversary has access to the source code of

the program, therefore s/he is able to glean all source-level information and/or deterministic compilation results from it (e.g., find code gadgets within the program and determine non-califormed layouts of data structures). However, s/he does not have access to the host binary (e.g., server-side applications). Finally, we assume that all hardware is trusted: it does not contain and/or is not subject to bugs arising from exploits such as physical or glitching attacks. Due to its recent rise in relevance however, we maintain side channel attacks in our design of Califorms within the purview of our threats. Specifically, we accommodate attack vectors seeking to leak the location and value of security bytes.

7.2 Hardware Attacks and Mitigations

- **Metadata Tampering Attacks.** A key feature of Califorms as a metadata-based safety mechanism is the absence of programmer visible metadata in the general case (apart from a metadata bit in the page information maintained by higher privilege software). Beyond the implications for its storage overhead, this also means that our technique is immune to attacks that explicitly aim to leak or tamper the metadata to bypass the respective defense. This, in turn, implies a smaller attack surface so far as software maintenance of metadata is concerned.
- **Bit-granularity Attacks.** Califorms’s capability of fine-grained memory protection is the key enabler for intra-object overflow detection. However, our byte granular mechanism is not enough for protecting bit-fields without turning them into char bytes functionally. This should not be a major detraction since security bytes can still be added around composites of bit-fields.
- **Heterogeneous Architectural Attacks.** Califorms’ hardware modifications affect the memory hierarchy. Hence, its protection is lost whenever one of its layers is bypassed (e.g., heterogeneous architectures or DMA is used). Mitigating this requires that these mechanisms always respect the security byte semantics by propagating them along the respective memory structures and detecting accesses to them. If the algorithm used for califorming is used by accelerators then attacks through heterogeneous components can also be averted.
- **Side-Channel Attacks.** Our design takes multiple steps to be resilient to side channel attacks. Firstly, we purposefully avoid timing variances introduced due to our hardware modifications in order to avoid timing based side channel attacks. Additionally, to avoid speculative execution side channels ala Spectre [12], our design returns zero on a load to a security byte, thus preventing speculative disclosure of metadata. We augment this further by requiring that deallocated objects (heap or stack) be zeroed out in software [13]. This is to avoid the following attack scenario: consider a case if the attacker somehow knows that the padding locations should contain a non-zero value (for instance, because s/he knows

the object allocated at the same location prior to the current object had non-zero values). However, while speculatively disclosing memory contents of the object, s/he discovers that the padding location contains a zero instead. As such, s/he can infer that the padding there contains a security byte. If deallocations were accompanied with zeroing, however, this assumption does not hold.

7.3 Software Attacks and Mitigations

- **Coverage-Based Attacks.** For califorming the padding bytes (in an object), we need to know the precise type information of the allocated object. This is not always possible in C-style programs where `void*` allocations may be used. In these cases, the compiler may not be able to infer the correct type, in which case intra-object support may be skipped for such allocations. Similarly, our metadata insertion policies (viz., intelligent and full) require changes to the type layouts. This means that interactions with external modules that have not been compiled with Califorms support may need (de)serialization to remain compatible. For an attacker, such points in execution may appear lucrative because of inserted security bytes getting stripped away in those short periods. We note however that the opportunistic policy can still remain in place to offer some protection.

On the other hand, for those interactions that remain oblivious to type layout modifications (e.g., passing a pointer to an object that shall remain opaque within the external module), our hardware-based implicit checks have the benefit of persistent tampering protection, even across binary module boundaries.

- **Whitelisting Attacks.** Our concession of allowing whitelisting of certain functions was necessary to make Califorms more usable in common environments without requiring significant source modifications. However, this also creates a vulnerability window wherein an adversary can piggy back on these functions in the source to bypass our protection. To confine this vector, we keep the number of whitelisted functions as minimal as possible.

- **Derandomization Attacks.** Since Califorms can be bypassed if an attacker can guess a security bytes location, it is crucial that it be placed unpredictably. For the attacker to carry out a guessing attack, s/he first needs to obtain the virtual memory address of the object they want to corrupt, and then overwrite a certain number of bytes within that object. To know the address of the object of interest, s/he typically has to scan the process' memory: the probability of scanning without touching any of the security bytes is $(1 - P/N)^O$ where O is number of allocated objects, N is the size of each object, and P is number of security bytes within that object. With 10% padding ($P/N = 0.1$), when O reaches 250, the attack success goes to 10^{-20} . If the attacker can somehow reduce O to 1, which represents the ideal case for the attacker, the probability of guessing the element of

interest is $1/7^n$ (since we insert 1–7 wide security bytes), compounding as the number of paddings to be guessed ($= n$) increases.

The randomness is, however, introduced statically akin to `randstruct` plugin introduced in recent Linux kernels which randomizes structure layout of those which are specified (it does not offer detection of rogue accesses unlike Califorms do) [14, 15]. The static nature of the technique may make it prone to brute force attacks like BROP [16] which repeatedly crashes the program until the correct configuration is guessed. This could be prevented by having multiple versions of the same binary with different padding sizes or simply by better logging, when possible. Another mitigating factor is that BROP attacks require specific type of program semantics, namely, automatic restart-after-crash with the same memory layout. Applications with these semantics can be modified to spawn with a different padding layout in our case and yet satisfy application level requirements.

8 Performance Evaluation

8.1 Hardware Overheads

- **Cache Access Latency Impact of Califorms.** Califorms adds additional state and operations to the L1 data cache and the interface between the L1 and L2 caches. The goal of this section is to evaluate the access latency impact of the additional state and operations described in Section 5. Qualitatively, the metadata area overhead of L1 Califorms is 12.5%, and the access latency should not be impacted as the metadata lookup can happen in parallel with the L1 tag access; the L1 to/from L2 califorms conversion should also be simple enough so that its latency can be completely hidden. However, the metadata area overhead can increase the L1 tag access latency and the conversions might add little latency. Without loss of generality, we measure the access latency impact of adding califorms-bitvector on a 32KB direct mapped L1 cache in the context of a typical energy optimized tag, data, formatting L1 pipeline with multicycle fill/spill handling. For the implementation we use the 65nm TSMC core library, and generate the SRAM arrays with the ARM Artisan memory compiler. Table 2 summarizes the results for the L1 Califorms (califorms-bitvector).

As expected, the overheads associated with the califorms-bitvector are minor in terms of delay (1.85%) and power consumption (2.12%). We found the SRAM area to be the dominant component in the total cache area (around 98%) where the overhead was 18.69%, higher than 12.5%. The results of fill/spill modules are reported separately in the right hand side of Table 2.

The latency impact of the fill operation is within the access period of the L1 design. Thus, the califorming operation can be folded completely within the pipeline stages that are responsible for bringing cache lines from L2 to L1.

Table 2. Area, delay and power overheads of Califorms (GE represents gate equivalent). L1 Califorms (califorms-bitvector) adds negligible delay and power overheads to the L1 cache access.

Design Name	Main synthesis results			L1 overheads			Fill overheads			Spill overheads		
	Area (GE)	Delay (ns)	Power (mW)	Area (%)	Delay(%)	Power (%)	Area (GE)	Delay (ns)	Power (mW)	Area (GE)	Delay (ns)	Power (mW)
Baseline	347,329.19	1.62	15.84	—	—	—	—	—	—	—	—	—
L1 Califorms	412,263.87	1.65	16.17	18.69	1.85	2.12	8,957.16	1.43	0.18	34,561.80	5.50	0.52

The timing delay of the (less performance sensitive) spill operation is larger than that of the fill operation (5.5ns vs. 1.4ns) as we use pure combinational logic to construct the califorms-sentinel format in one cycle, as shown in Figure 8. This cycle period can be reduced by dividing the operations of Algorithm 1 (lines 7 to 11) into two or more pipeline stages. For instance, getting the locations of the first four security bytes (line 8) consists of four successive combinational blocks (each detecting one security byte) in our evaluated design. This logic can be easily pipelined into four stages. Therefore we believe that the latency of both the fill and spill operations can be minimal (or completely hidden) in the pipeline.

• **Performance with Additional Cache Access Latency.** Our results from the VLSI implementation imply that there will be no additional L2/L3 latency imposed by implementing Califorms. However, this might not be the case depending on several implementation details (e.g., target clock frequency) so we pessimistically assume that the L2/L3 access latency incurs additional one cycle latency overhead. In order to evaluate the performance of the additional latency posed by Califorms, we perform detailed microarchitectural simulations.

We use ZSim [17] as the processor simulator and use PinPoints [18] with Intel Pin [19], to select representative simulation regions of the SPEC CPU2006 benchmarks with ref inputs compiled with Clang version 6.0.0 with “-O3 -fno-strict-aliasing” flags. We do not warmup the simulator upon executing each SimPoint region but instead use a relatively large interval length of 500M instructions to avoid any warmup issues. We set MaxK used in SimPoint region selection to 30.⁴

Table 3 shows the parameters of the processor, an Intel Westmere-like out-of-order core which has been validated against a real system whose performance and microarchitectural events to be commonly within 10% [17]. We evaluate the performance when both L2 and L3 caches incur additional latency of one cycle.

As shown in Figure 10 slowdowns range from 0.24% (hmmr) to 1.37% (xalancbmk). The average performance

⁴For some benchmark-input pairs we have seen discrepancies in the number of instructions measured by PinPoints vs. ZSim and thus the appropriate SimPoint regions might not be simulated. Those inputs are: foreman_ref_encoder_main for h264ref and pds-50 for soplex. Also, due to time constraints, we could not complete executing SimPoint for h264ref with sss_encoder_main input and excluded it from the evaluation.

Table 3. Hardware configuration of the simulated system.

Core	x86-64 Intel Westmere-like OoO core at 2.27GHz
L1 inst. cache	32KB, 4-way, 3-cycle latency
L1 data cache	32KB, 8-way, 4-cycle latency
L2 cache	256KB, 8-way, 7-cycle latency
L3 cache	2MB, 16-way, 27-cycle latency
DRAM	8GB, DDR3-1333

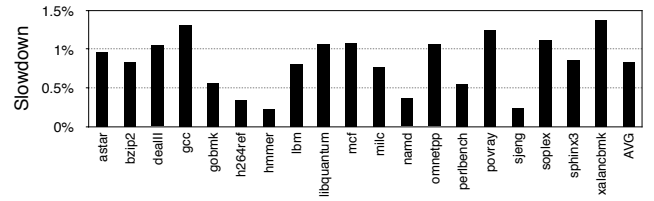
**Figure 10.** Slowdown with additional one-cycle access latency for both L2 and L3 caches.

slowdown is 0.83% which is negligible and is well in the range of error when executed on real systems.

8.2 Software Performance Overheads

Our evaluations so far revealed that the hardware modifications required to implement Califorms add little or no performance overhead. Here, we evaluate the overheads incurred by the two software based changes required to enable intra-object memory safety with Califorms: the effect of underutilized memory structures (e.g., caches) due to additional security bytes, and the additional work necessary to issue CFORM instructions (and the overhead of executing the instructions themselves).

• **Evaluation Setup.** We run the experiments on an Intel Skylake-based Xeon Gold 6126 processor running at 2.6GHz with RHEL Linux 7.5 (kernel 3.10). We omit deaII and omnetpp since the shared libraries installed on RHEL are too old to execute these two Califorms enabled binaries, and gcc since it fails when executed with the memory allocator with inter-object spatial and temporal memory safety support. The remaining 16 SPEC CPU2006 C/C++ benchmarks are compiled with our modified Clang version 6.0.0 with “-O3 -fno-strict-aliasing” flags. We use the ref inputs and run to completion. We run each benchmark-input pair five times and use the shortest execution time as its performance. For the benchmarks with multiple ref inputs, the sum of the

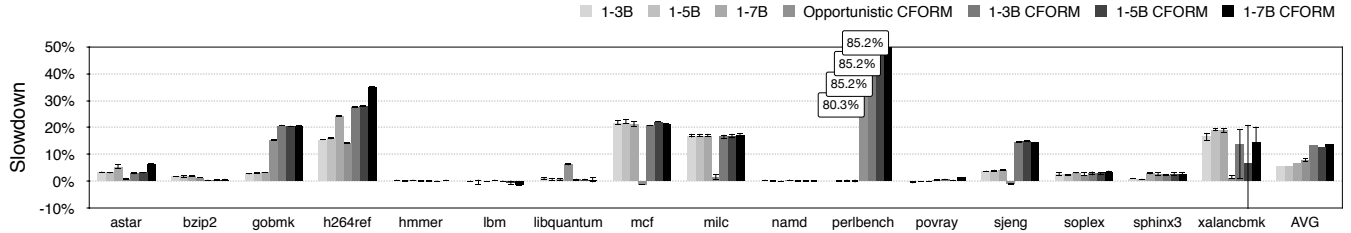

Figure 11. Slowdown of the opportunistic policy, and full insertion policy with random sized security bytes (with and without CFORM instructions). The average slowdowns of opportunistic and full insertion policies are 6.2% and 14.2%, respectively.

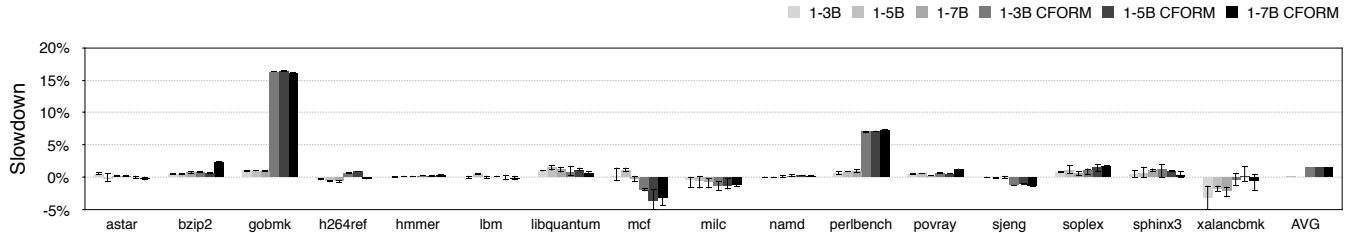

Figure 12. Slowdown of the intelligent insert policy with random sized security bytes (with and without CFORM instructions). The average slowdown is 2.0%.

execution time of all the inputs are used as their execution times.⁵

We estimate the performance impact of executing a CFORM instruction by emulating it with a dummy store instruction that writes some value to the corresponding cache line’s padding byte. Since one CFORM instruction can caliform the entire cache line, issuing one dummy store instruction per to-be-califormed cache line suffices. In order to issue the dummy stores, we implement a LLVM pass to instrument the code to hook into memory allocations and deallocations. We then retrieve the type information to locate the padding bytes, calculate the number of dummy stores and the address they access, and finally emit them. Therefore, all the software overheads we need to pay to enable Califorms are accounted for in our evaluation.

For the random sized security bytes, we evaluate three variants: we fix the minimum size to one byte while varying the maximum size to three, five and seven bytes (i.e., on average the amount of security bytes inserted are two, three and four bytes, respectively). In addition, in order to account for the randomness introduced by the compiler, we generate three different versions of binaries for the same setup (e.g., three versions of *astar* with random sized paddings of minimum one byte and maximum three bytes). The error bars in the figure represent the minimum and the maximum execution times among 15 executions (three binaries \times five

runs) and the average of the execution times is represented as the bar.

• **Performance of the Opportunistic and Full Insertion Policies with CFORM Instructions.** Figure 11 presents the slowdown incurred by three set of strategies: full insertion policy (with random sized security bytes) *without* CFORM instructions, the opportunistic policy *with* CFORM instructions, and the full insertion policy *with* CFORM instructions. Since the first strategy does not execute CFORM instructions it does not offer any security coverage, but is shown as a reference to showcase the performance breakdown of the third strategy (cache underutilization vs. executing CFORM instructions).

First, we focus on the three variants of the first strategy, which is shown in the three left most bars. We can see that different sizes of random sized security bytes does not make a large difference in terms of performance. The average slowdown of the three variants for the policy without CFORM instructions are 5.5%, 5.6% and 6.5%, respectively. This can be backed up by our results shown in Figure 4, where the average slowdowns of additional padding of two, three and four bytes ranges from 5.4% to 6.2%. Therefore in order to achieve higher security coverage without losing performance, using a random sized bytes of, minimum of one byte and maximum of seven bytes, is promising. When we focus on individual benchmarks, we can see that a few benchmarks including *h264ref*, *mcf*, *milc* and *omnetpp* incur noticeable slowdowns (ranging from 15.4% to 24.3%).

Next, we examine the opportunistic policy *with* CFORM instructions, which is shown in the middle (fourth) bar. Since this strategy does not add any additional security bytes, the overheads are purely due to the work required to setup and

⁵We use the arithmetic mean of the speedup (execution time of the original system divided by that of the system with additional latency) to compute the average, or in other words, we are interested in a condition where the workloads are not fixed and all types of workloads are equally probable on the target system [20, 21].

execute CFORM instructions. The average slowdown of this policy is 7.9%. There are benchmarks which encounter a slowdown of more than 10%, namely `gobmk`, `h264ref` and `perlbench`. The overheads are due to frequent allocations and deallocations made during program execution, where the programs have to calculate and execute CFORM instructions upon every event (since every compound data type will be/was califormed). For instance `perlbench` is notorious for being malloc-intensive, and reported as such elsewhere [2].

Lastly the third policy, the full insertion policy *with* CFORM instructions, offers the highest security coverage in Califorms based system with the highest average slowdown of 14.0% (with the random sized security bytes of maximum seven bytes). Nearly half (seven out of 16) the benchmarks encounter a slowdown of more than 10%, which might not be suitable for performance-critical environments, and thus the user might want to consider the use of the following intelligent insertion policy.

- **Performance of the Intelligent Insertion Policy with CFORM Instructions.** Figure 12 shows the slowdowns of the intelligent insertion policy with random sized security bytes (*with* and *without* CFORM instructions, in the same spirit as Figure 11). First we focus on the strategy without executing CFORM instructions (the three bars on the left). The performance trend is similar such that the three variants with different random sizes have little performance difference, where the average slowdown is 0.2% with the random sized security bytes of maximum seven bytes. We can see that none of the programs incurs a slowdown of greater than 5%. Finally with CFORM instructions (three bars on the right), `gobmk` and `perlbench` have slowdowns of greater than 5% (16.1% for `gobmk` and 7.2% for `perlbench`). The average slowdown is 1.5%, where considering its security coverage and performance overheads the intelligent policy might be the most practical option for many environments.

9 Related Work

Implementations of various safety mechanisms in hardware were very popular in the 70–90s, introducing crucial legacy techniques such as capabilities, segmentation and virtual memory. Subsequently, the focus shifted towards scalability and performance until the last decade, when security saw a revival in interest. In this section, we only focus on the latter group of modern hardware based security techniques, and compare them to Califorms. Previous hardware solutions in this domain can be broadly categorized into the following three classes: disjoint metadata whitelisting, cojoined metadata whitelisting and inlined metadata blacklisting, as presented in Figure 13.

- **Disjoint Metadata Whitelisting.** This class of techniques, also called base and bounds, attaches bounds metadata with every pointer, bounding the region of memory they can legitimately dereference (see Figure 13(a)).

Hardbound [8] was the first hardware proposal to provide spatial memory safety using this mechanism. Intel MPX [4] is similar, but also introduces explicit architectural interface (registers and instructions) for managing bounds information. Temporal safety was introduced to this scheme by storing an additional “version” information along with the pointer metadata and verifying that no stale versions are ever retrieved [22, 23]. BOGO [24] adds temporal safety to MPX by invalidating all pointers to freed regions in MPX’s lookup table. Introduced about 35 years ago in commercial chips like Intel 432 and IBM System/38, the CHERI [9] revived capability based architectures. It has similar bounds-checking guarantees, in addition to having other metadata fields pertaining to permissions, etc⁶. PUMP [11], on the other hand, is a general-purpose framework for metadata propagation, and can be used for propagating pointer bounds.

Typically, per pointer metadata is stored separately from the pointer in a shadow memory region, in order to maintain legacy pointer layout assumptions. Thus, although metadata storage overhead scales according to the number of pointers in principle, techniques generally reserve a fixed chunk of memory for easy lookup. Owing to this disjoint nature, metadata access therefore requires additional memory operations, which individual proposals seek to minimize with caching and other optimizations. Regardless, disjoint metadata introduces atomicity concerns potentially resulting in false positives and negatives or complicating coherence designs at the least (e.g., MPX is not thread-safe). Explicit specification of bounds per pointer also allows bounds-narrowing in principle, wherein pointer bounds can be tailored to protect individual elements in a composite memory object (for instance, when passing the pointer to an element to another function). However, commercial compilers do not support this feature for MPX due to the complexity of compiler analyses required. Furthermore, compatibility issues with untreated modules (unprotected libraries, for instance) also introduces real-world deployability concerns for these techniques. For instance MPX drops its bounds when protected pointers are modified by unprotected modules, while CHERI does not support it at all. MPX additionally makes bounds checking explicit, thus introducing a marginal computational overhead to bounds management as well.

- **Cojoined Metadata Whitelisting.** Originally introduced in the IBM System/360 mainframes, this mechanism assigns a “color” to memory chunks as well as pointers. As such, the runtime check for access validity simply consists of comparing the colors of the pointer and accessed memory (see Figure 13(b)).

⁶A recent version of CHERI [10], however, manages to compress metadata to 128 bits and change pointer layout to store it with the pointer value (i.e., implementing base and bounds as cojoined metadata whitelisting), accordingly introducing instructions to manipulate them specifically.

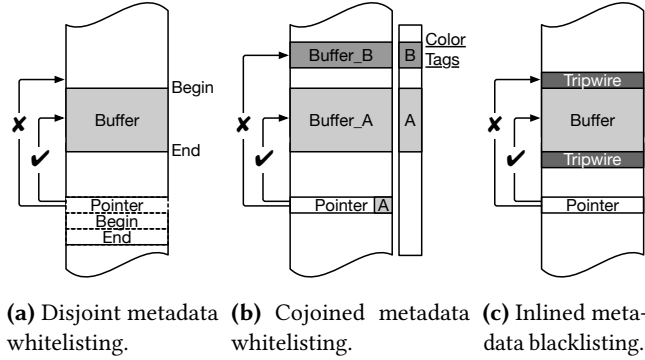

Figure 13. Three main classes of hardware solutions for memory safety.

This technique is currently commercially deployed by SPARC ADI [3],⁷ which refactors unused higher order bits in pointers to store the color. Color associated with memory is stored in the ECC bits while in memory, and dedicated per line metadata bits while in cache. Due to the latter feature, metadata storage does not occupy any additional memory in the program’s address space.⁸ Additionally, since metadata bits are acquired along with concomitant data, extra memory operations are obviated. For the same reason, it is also compatible with unprotected modules since the checks are implicit as well. Temporal safety is trivially achieved by assigning a different color when memory regions are reused. However, intra-object protection or bounds-narrowing is not supported as there is no means for “overlapping” colors. Furthermore, protection is also dependent on the number of metadata bits employed, since it determines the number of colors that can be assigned. So, while color reuse allows ADI to scale and limit metadata storage overhead, it can also be exploited by this vector. Another disadvantage of this technique, specifically due to inlining metadata in pointers, is that it only supports 64-bit architectures. Narrower pointers would not have enough spare bits to accommodate color information.

• **Inlined Metadata Blacklisting.** Another line of work, also referred to as tripwires, aims to detect overflows by simply blacklisting a patch of memory on either side of a buffer, and flagging accesses to this patch (see Figure 13(c)). This is very similar to contemporary canary design [30], but there are a few critical differences. First, canaries only detect overwrites, not overreads. Second, hardware tripwires trigger instantaneously, whereas canaries need to be periodically checked for integrity, providing a period of attack to time of use window. Finally, unlike hardware tripwires, canary values can be leaked or tampered, and thus mimicked.

⁷ARM has a similar upcoming Memory Tagging [25] feature, whose implementation details are unclear, as of this work.

⁸When a memory is swapped, color bits are copied into memory by the OS however.

Proposal	Protection Granularity	Intra-Object	Binary Composability	Temporal Safety
Hardbound [8]	Byte	✓ [*]	✗	✗
Watchdog [22]	Byte	✓ [*]	✗	✓
WatchdogLite [23]	Byte	✓ [*]	✗	✓
Intel MPX [4]	Byte	✓ [*]	✗ [‡]	✗
BOGO [24]	Byte	✓ [*]	✗ [‡]	✓
PUMP [11]	Word	✗	✓	✓
CHERI [9]	Byte	✗ [†]	✗	✗
CHERI concentrate [10]	Byte	✗ [†]	✗	✗
SPARC ADI [3]	Cache line	✗	✓	✓ [§]
SafeMem [26]	Cache line	✗	✓	✗
REST [27]	8–64B	✗	✓	✓ [¶]
Califorms	Byte	✓	✓	✓ [¶]

Table 4. Security comparison against previous hardware techniques. *Achieved with bounds narrowing. †Although the hardware supports bounds narrowing, CHERI foregoes it since doing so compromises capability logic [28]. ‡Execution compatible, but protection dropped when external modules modify pointer. §Limited to 13 tags. ¶Allocator should randomize allocation predictability.

SafeMem [26] implements tripwires by repurposing ECC bits in memory to mark memory regions invalid, thus trading off reliability for security. On processors supporting speculative execution, however, it might be possible to speculatively fetch blacklisted lines into the cache without triggering a faulty memory exception. Unless these lines are flushed immediately after, SafeMem’s blacklisting feature can be trivially bypassed. Alternatively, REST [27] achieves the same by storing a predetermined large random number, in the form of a 64B tokens, in the memory to be blacklisted. Violations are detected by comparing cache lines with the token when they are fetched. REST provides temporal safety by quarantining freed memory, and not reusing them for subsequent allocations. Compatibility with unprotected modules is easily achieved as well, since tokens are part of the program’s address space and all access are implicitly checked. However, intra-object safety was not supported by REST owing to the large memory overhead such heavy usage of tokens would entail.

Since it operates on the principle of detecting memory accesses to security bytes, which are in turn stored along with program data, Califorms belongs to the inlined metadata class of defenses. However, it is different from other works in the class in one key aspect — granularity. While both REST and SafeMem blacklisted at the cache line granularity, Califorms does so at the byte granularity. It is this property that enables us to provide intra-object safety with negligible performance and memory overheads, unlike previous work in the area. For inter-object spatial safety and temporal safety, we employ the same design principles as REST. Hence, our safety guarantees are a *strict superset* of those provided by previous schemes in this class (spatial safety by blacklisting and temporal safety by quarantining).

Proposal	Metadata Overhead	Memory Overhead	Performance Overhead	Main Operations
Hardbound [8]	0–2 words per ptr, 4b per word	\propto # of ptrs and prog memory footprint	\propto # of ptr derefs	1–2 mem ref for bounds (may be cached), check μ ops.
Watchdog [22]	4 words per ptr	\propto # of ptrs and allocations	\propto # of ptr derefs	1–3 mem ref for bounds (may be cached), check μ ops.
WatchdogLite [23]	4 words per ptr	\propto # of ptrs and allocations	\propto # of ptr ops	1–3 mem ref for bounds (may be cached), check & propagate insns.
Intel MPX [4]	2 words per ptr	\propto # of ptrs	\propto # of ptr derefs	2+ mem ref for bounds (may be cached), check & propagate insns.
BOGO [24]	2 words per ptr	\propto # of ptrs	\propto # of ptr derefs	MPX ops + ptr miss exception handling, page permission mods.
PUMP [11]	64b per cache line	\propto Prog memory footprint	\propto # of ptr ops	1 mem ref for tags, may be cached, fetch and chk rules; propagate tags.
CHERI [9]	256b per ptr	\propto # of ptrs and physical mem	\propto # of ptr ops	1+ mem ref for capability (may be cached), capability management insns.
CHERI concentrate [10]	Ptr size is 2x	\propto # of ptrs	\propto # of ptr ops	Wide ptr load (may be cached), capability management insns.
SPARC ADI [3]	4b per cache line	\propto Prog memory footprint	\propto # of tag (un)set ops	(Un)set tag.
SafeMem [26]	2x blacklisted memory	\propto Blacklisted memory	\propto # of ECC (un)set ops	Syscall to scramble ECC, copy data content.
REST [27]	8–64B token	\propto Blacklisted memory	\propto # of arm/disarm insns	Execute arm/disarm insns.
Califorms	Byte granular security byte	\propto Blacklisted memory	\propto # of CFORM insns.	Execute CFORM insns.

Table 5. Performance comparison against previous hardware techniques.

Proposal	Core	Caches/TLB	Memory	Software
Hardbound [8]	μ op injection & logic for ptr meta, extend reg file and data path to propagate ptr meta	Tag cache and its TLB	N/A	Compiler & allocator annotates ptr meta
Watchdog [22]	μ op injection & logic for ptr meta, extend reg file and data path to propagate ptr meta	Ptr lock cache	N/A	Compiler & allocator annotates ptr meta
WatchdogLite [23]		N/A	N/A	Compiler & allocator annotates ptrs, compiler inserts meta propagation and check insns
Intel MPX [4]	Unknown (closed platform [29], design likely similar to Hardbound)			Compiler & allocator annotates ptrs, compiler inserts meta propagation and check insns
BOGO [24]	Unknown (closed platform [29], design likely similar to Hardbound)			MPX mods + kernel mods for bounds page right management
PUMP [11]	Extend all data units by tag width, modify pipeline stages for tag checks, new miss handler	Rule cache	N/A	Compiler & allocator (un)sets memory, tag ptrs
CHERI [9]	Capability reg file, coprocessor integrated with pipeline	Capability caches	N/A	Compiler & allocator annotates ptrs, compiler inserts meta propagation and check insns
CHERI concentrate [10]	Modify pipeline to integrate ptr checks	N/A	N/A	Compiler & allocator annotates ptrs, compiler inserts meta propagation and check insns
SPARC ADI [3]	Unknown (closed platform)			Compiler & allocator (un)sets memory, tag ptrs
SafeMem [26]	N/A	N/A	Repurposes ECC bits	
REST [27]	N/A	1–8b per L1D line, 1 comparator	N/A	Compiler & allocator (un)sets tags, allocator randomizes allocation order/placement
Califorms	N/A	8b per L1D line, 1b per L2/L3 line	Use unused ECC bits	Compiler & allocator mods to (un)set tags, compiler inserts intra-object spacing

Table 6. Comparison of implementation complexity among previous hardware techniques.

9.1 Comparison with Califorms

Tables 4, 5, and 6 summarize the performance, security, and implementation characteristics of the hardware based memory safety techniques discussed in this section respectively. Califorms has the advantage of requiring simpler hardware

modifications and being faster than disjoint metadata based whitelisting systems. The hardware savings mainly stem from the fact that our metadata resides with program data; it does not require explicit propagation while additionally obviating all lookup logic. This significantly reduces our

design’s implementation costs. Califorms also has lower performance and energy overheads since it neither requires multiple memory accesses, nor does it incur any significant checking costs. However, unlike them, Califorms can be bypassed if accesses to security bytes can be avoided (further discussed in Section 7). This safety-vs.-complexity tradeoff is critical to deployability and we argue that our design point is more practical. This is because designers have to contend with integrating these features to already complicated processor designs, without introducing additional bugs while also keeping the functionality of legacy software intact. This is a hard balance to strike [4].

On the other hand, ideal cojoined metadata mechanisms would have comparable slowdowns and similar compiler requirements. However practical implementations like ADI exhibits some crucial differences from the ideal.

- It is limited to 64-bit architectures, which excludes a large portion of embedded and IoT processors that operate on 32-bit or narrower platforms.
- It has finite number of colors since available tag bits are limited – ADI supports 13 colors with 4 tag bits. This is important because reusing colors proportionally reduces the safety guarantees of these systems in the event of a collision.
- It operates at the coarse granularity of cache line width, and hence, is not practically applicable for intra-object safety.

On the contrary, Califorms is agnostic of architecture width and is, hence, better suited for deployment over a more diverse device environment. In terms of safety, collision is not an issue for our design either. Hence, unlike cojoined metadata systems, our security does not scale inversely with the number of allocations in the program (see Section 7 for a detailed discussion). Finally, our fine-grained protection also makes us suitable for intra-object memory safety which is a non-trivial threat in modern security [31].

10 Conclusion

Califorms is a hardware primitive which allows blacklisting a memory location at byte granularity with low area and performance overhead. A key observation behind Califorms is that a blacklisted region need not store useful data separately in most cases, since we can utilize byte-granular, existing or added, space present between object elements to store the metadata. This in-place compact data structure also avoids additional operations for extraneously fetching the metadata making it very performant in comparison. Further, by changing how data is stored within a cache line we are able to reduce the hardware area overheads substantially. Subsequently, if the processor accesses a califormed byte (or a security byte), due to programming errors or malicious attempts, it reports a privileged exception.

To provide memory safety, we use Califorms to insert security bytes within data structures (e.g., between fields of a struct) upon memory allocation and clear them on deallocation. Notably, by doing so, Califorms can even detect intra-object overflows, which is one of the prominent open problems in memory safety, despite decades of research in this area. We also described the necessary compiler and software support for providing memory safety using Califorms. To the best of our knowledge, this is the first hardware primitive which makes in place byte-granular blacklisting practical.

References

- [1] D. Weston and M. Miller. Windows 10 mitigation improvements. Black Hat USA, 2016.
- [2] Konstantin Serebryany, Derek Bruening, Alexander Potapenko, and Dmitry Vyukov. AddressSanitizer: a fast address sanity checker. In *USENIX ATC '12: Proceedings of the 2012 USENIX Annual Technical Conference*, pages 28–28, June 2012.
- [3] Hardware-assisted checking using Silicon Secured Memory (SSM). https://docs.oracle.com/cd/E37069_01/html/E37085/gphwb.html, 2015.
- [4] Oleksii Oleksenko, Dmitrii Kuvaiskii, Pramod Bhatotia, Pascal Felber, and Christof Fetzer. Intel MPX explained: a cross-layer analysis of the Intel MPX system stack. *Proceedings of the ACM on Measurement and Analysis of Computing Systems*, 2(2):28:1–28:30, 2018.
- [5] Dokyung Song, Julian Lettner, Prabhu Rajasekaran, Yeoul Na, Stijn Volckaert, Per Larsen, and Michael Franz. SoK: sanitizing for security. In *IEEE S&P '19: Proceedings of the 40th IEEE Symposium on Security and Privacy*, May 2019.
- [6] Gregory J Duck and Roland H C Yap. EffectiveSan: type and memory error detection using dynamically typed C/C++. In *PLDI '18: Proceedings of the 39th ACM SIGPLAN Conference on Programming Language Design and Implementation*, pages 181–195, June 2018.
- [7] Kostya Serebryany, Evgenii Stepanov, Aleksey Shlyapnikov, Vlad Tsyklevich, and Dmitry Vyukov. Memory tagging and how it improves C/C++ memory safety. *arXiv.org*, February 2018.
- [8] Joe Devietti, Colin Blundell, Milo M K Martin, and Steve Zdancewic. HardBound: architectural support for spatial safety of the C programming language. In *ASPLOS XIII: Proceedings of the 13th International Conference on Architectural Support for Programming Languages and Operating Systems*, pages 103–114, March 2008.
- [9] Jonathan Woodruff, Robert N M Watson, David Chisnall, Simon W Moore, Jonathan Anderson, Brooks Davis, Ben Laurie, Peter G Neumann, Robert Norton, and Michael Roe. The CHERI capability model: revisiting RISC in an age of risk. In *ISCA '14: Proceedings of the 41st International Symposium on Computer Architecture*, pages 457–468, June 2014.
- [10] Jonathan Woodruff, Alexandre Joannou, Hongyan Xia, Anthony Fox, Robert Norton, David Chisnall, Brooks Davis, Khilan Gudka, Nathaniel W Filardo, A Theodore Marketos, Michael Roe, Peter G Neumann, Robert Nicholas Maxwell Watson, and Simon Moore. CHERI concentrate: practical compressed capabilities. *IEEE Transactions on Computers*, pages 1–1, April 2019.
- [11] Udit Dhawan, Catalin Hritcu, Raphael Rubin, Nikos Vasilakis, Silviu Chiricescu, Jonathan M Smith, Thomas F Knight, Jr, Benjamin C Pierce, and Andre DeHon. Architectural support for software-defined metadata processing. In *ASPLOS '15: Proceedings of the 20th International Conference on Architectural Support for Programming Languages and Operating Systems*, pages 487–502, March 2015.
- [12] Paul Kocher, Daniel Genkin, Daniel Gruss, Werner Haas, Mike Hamburg, Moritz Lipp, Stefan Mangard, Thomas Prescher, Michael Schwarz, and Yuval Yarom. Spectre attacks: exploiting speculative execution.

- In *IEEE S&P '19: Proceedings of the 40th IEEE Symposium on Security and Privacy*, May 2019.
- [13] Alyssa Milburn, Herbert Bos, and Cristiano Giuffrida. SafeInit: comprehensive and practical mitigation of uninitialized read vulnerabilities. In *NDSS '17: Proceedings of the 2017 Network and Distributed System Security Symposium*, pages 1–15, February 2017.
- [14] Introduce struct layout randomization plugin. <https://lkml.org/lkml/2017/5/26/558>, May 2017.
- [15] Randomizing structure layout. <https://lwn.net/Articles/722293/>, May 2017.
- [16] Andrea Bittau, Adam Belay, Ali Mashtizadeh, David Mazieres, and Dan Boneh. Hacking blind. In *IEEE S&P '14: Proceedings of the 35th IEEE Symposium on Security and Privacy*, pages 227–242, May 2014.
- [17] Daniel Sanchez and Christos Kozyrakis. ZSim: fast and accurate microarchitectural simulation of thousand-core systems. In *ISCA '13: Proceedings of the 40th International Symposium on Computer Architecture*, pages 475–486, June 2013.
- [18] Harish Patil, Robert Cohn, Mark Charney, Rajiv Kapoor, Andrew Sun, and Anand Karunanidhi. Pinpointing representative portions of large Intel® Itanium® programs with dynamic instrumentation. *MICRO-37: Proceedings of the 37th IEEE/ACM International Symposium on Microarchitecture*, pages 81–92, December 2004.
- [19] Chi-Keung Luk, Robert Cohn, Robert Muth, Harish Patil, Artur Klauser, Geoff Lowney, Steven Wallace, Vijay Janapa Reddi, and Kim Hazelwood. Pin: building customized program analysis tools with dynamic instrumentation. In *PLDI '05: Proceedings of the 26th ACM SIGPLAN Conference on Programming Language Design and Implementation*, pages 190–200, June 2005.
- [20] Lieven Eeckhout. *Computer architecture performance evaluation methods*. Morgan & Claypool Publishers, 1st edition, 2010.
- [21] Lizy Kurian John. More on finding a single number to indicate overall performance of a benchmark suite. *ACM SIGARCH Computer Architecture News*, 32(1):3–8, March 2004.
- [22] Santosh Nagarakatte, Milo M K Martin, and Steve Zdancewic. Watchdog: hardware for safe and secure manual memory management and full memory safety. In *ISCA '12: Proceedings of the 39th International Symposium on Computer Architecture*, pages 189–200, June 2012.
- [23] Santosh Nagarakatte, Milo M K Martin, and Steve Zdancewic. WatchdogLite: hardware-accelerated compiler-based pointer checking. In *CGO '14: Proceedings of the 12th IEEE/ACM International Symposium on Code Generation and Optimization*, pages 175–184, February 2014.
- [24] Tong Zhang, Dongyoon Lee, and Changhee Jung. BOGO: buy spatial memory safety, get temporal memory safety (almost) free. In *ASPLOS '19: Proceedings of the 24th International Conference on Architectural Support for Programming Languages and Operating Systems*, pages 631–644, April 2019.
- [25] ARM A64 instruction set architecture for ARMv8-A architecture profile. https://static.docs.arm.com/ddi0596/a/DDI_0596_ARM_a64_instruction_set_architecture.pdf, 2018.
- [26] Feng Qin, Shan Lu, and Yuanyuan Zhou. SafeMem: exploiting ECC-memory for detecting memory leaks and memory corruption during production runs. In *HPCA '05: Proceedings of the IEEE 11th International Symposium on High Performance Computer Architecture*, pages 291–302, February 2005.
- [27] Kanad Sinha and Simha Sethumadhavan. Practical memory safety with REST. In *ISCA '18: Proceedings of the 45th International Symposium on Computer Architecture*, pages 600–611, June 2018.
- [28] Brooks Davis, Khilan Gudka, Alexandre Joannou, Ben Laurie, A Theodore Markettos, J Edward Maste, Alfredo Mazinghi, Edward Tomasz Napierala, Robert M Norton, Michael Roe, Peter Sewell, Robert N M Watson, Stacey Son, Jonathan Woodruff, Alexander Richardson, Peter G Neumann, Simon W Moore, John Baldwin, David Chisnall, James Clarke, and Nathaniel Wesley Filardo. Cheriabi: enforcing valid pointer provenance and minimizing pointer privilege in the POSIX C run-time environment. In *ASPLOS '19: Proceedings of the 24th International Conference on Architectural Support for Programming Languages and Operating Systems*, pages 379–393, April 2019.
- [29] Junjing Shi, Qin Long, Liming Gao, Michael A. Rothman, and Vincent J. Zimmer. Methods and apparatus to protect memory from buffer overflow and/or underflow, April 2018. International patent WO/2018/176339.
- [30] Crispin Cowan, Calton Pu, Dave Maier, Heather Hintony, Jonathan Walpole, Peat Bakke, Steve Beattie, Aaron Grier, Perry Wagle, and Qian Zhang. StackGuard: automatic adaptive detection and prevention of buffer-overflow attacks. In *USENIX Security '98: Proceedings of the 7th USENIX Security Symposium*, pages 1–15, January 1998.
- [31] Kangjie Lu, Chengyu Song, Taesoo Kim, and Wenke Lee. UniSan: proactive kernel memory initialization to eliminate data leakages. In *CCS '16: Proceedings of the 23rd ACM SIGSAC Conference on Computer and Communications Security*, pages 920–932, October 2016.

Appendices

A CALIFORMS Variants

Here we present two other variants of califorms-bitvector (designed for the L1 cache) which have less storage overhead (but with additional complexity) compared to the one presented in [Section 5.1](#).

- **Califorms-4B.** The first variant has 4B of additional storage per 64B cache line. This Califorms stores the bit vector *within* a security byte (illustrated in [Figure 14](#)). Since a single byte bit vector (which can be stored in one security byte) can represent the state for 8B of data, we divide the 64B cache line into eight 8B chunks. If there is at least one security byte within an 8B chunk, we use one of those bytes to store the bit vector which represents the state of the chunk. For each chunk, we need to add four additional bits of storage. One bit to represent whether the chunk is *califormed* (contains a security byte), and three bits to specify which byte within the chunk stores the bit vector. Therefore, the additional storage is 4B (4-bit \times 8 chunks) or 6.25% per 64B cache line. The figure highlights the chunk [0] being califormed where the corresponding bit vector is stored in byte [1].

- **Califorms-1B.** We can further reduce the metadata overhead by restricting where we store the bit vector within the chunk (illustrated in [Figure 15](#)). The idea is to always store the bit vector in a fixed location (the 0th byte in the figure, or the header byte; similar idea used in califorms-sentinel). If the 0th byte is a security byte this works without additional modification. However if the 0th byte is *not* a security byte, we need to save its original value somewhere else so that we can retrieve it when required. For this purpose, we use one of the security bytes (the last security byte is chosen in the figure). This way we can eliminate three bits of metadata per chunk to address the byte which contains the bit vector. Therefore, the additional storage is 1B or 1.56% per 64B cache line. Similar with [Figure 14](#), the figure highlights the chunk [0] being califormed (where the corresponding bit vector is

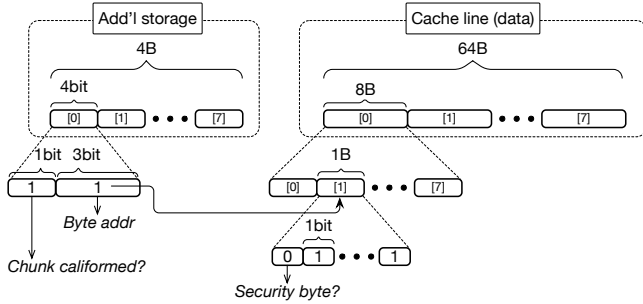

Figure 14. Califorms-bitvector that stores a bit vector inside security byte locations. The additional metadata (4-bit per 8B) specifies if the corresponding chunk contains a security byte, and if it does, where in the chunk the bit vector is stored in. HW overhead of 4B per 64B cache line.

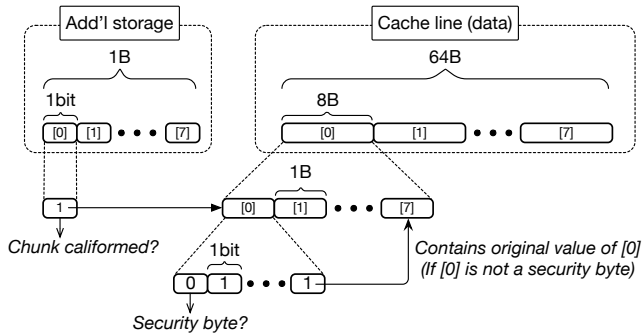

Figure 15. Califorms-bitvector that stores a bit vector in the header (0th) byte of the chunk. If the header byte is normal data (not a security byte), its original value is stored in the last security byte. The additional metadata (1-bit per 8B) specifies if the corresponding chunk contains a security byte. HW overhead of 1B per 64B cache line.

stored in the first byte) and the original value of byte [0] stored in the last security byte, byte [7], within the chunk.

• **Evaluation.** We perform the same VLSI evaluation shown in Section 8.1 for the two additional califorms-bitvector introduced in this section. Table 7 presents the results. As we can

see, califorms-bitvector with 4B and 1B overheads incur 47% and 20% of extra delay, respectively, upon L1 hit compared to the califorms-bitvector with 8B overhead (49% and 22% additional delay compared to the baseline L1 data cache without Califorms). Also, both califorms-bitvector add almost the same overheads upon spill and fill operations (compared to the califorms-bitvector with 8B overhead) which are 9% delay and 30% energy for spill, and 34% delay and 17% energy for fill operations. Our evaluation reveals that califorms-bitvector with 1B overhead outperforms the other with 4B overhead both in terms of additional storage and access latency/energy. The reason is due to the design restriction of fixing the location of the header byte which allows faster lookup of the bit vector in the security byte. Califorms-bitvector with 1B overhead can be a good alternative (to the one presented in Section 5) in domains where area budget is more tight and/or less performance critical; e.g., embedded or IoT systems.

B Handling SIMD/Vector Instructions

As we have discussed in Section 6.2, precise loads and stores (along with the whitelisting capability) allow us to detect access violation upon memory instructions. However, there are certain class of instructions where issuing precise memory instructions may noticeably degrade performance. One class we can imagine is the SIMD/vector instructions where vector loads read a very wide (e.g., 512 bits for Intel AVX-512) word into the SIMD/vector register with a single instruction. For such instructions we can (1) operate the same way with regular loads by issuing precise loads (e.g., by using vector gather instructions with appropriate masks), (2) issue wide vector loads as is and trigger an exception whenever the vector load touches a security byte; this may introduce false positives but in reality data structures used by SIMD/vector instructions are unlikely to contain security bytes, or (3) add one bit per byte in the SIMD/vector registers so that we can propagate the security byte information, and trigger an exception whenever SIMD/vector instructions operates on a security byte. Investigating these alternatives are left for future work.

Table 7. Area, delay and power overheads of the three L1 Califorms (GE represents gate equivalent). The top two rows are presented in Table 2 and are shown here again for reference. Califorms-bitvector with 4B and 1B overheads incur 47% and 20% extra delay, respectively, upon L1 hit compared to califorms-bitvector with 8B overhead. Also the two Califorms add 9% delay and 30% energy upon spill and 34% delay and 17% energy upon fill.

Design Name	Main synthesis results			L1 overheads			Fill overheads			Spill overheads		
	Area (GE)	Delay (ns)	Power (mW)	Area (%)	Delay(%)	Power (%)	Area (GE)	Delay (ns)	Power (mW)	Area (GE)	Delay (ns)	Power (mW)
Baseline	347,329.19	1.62	15.84	—	—	—	—	—	—	—	—	—
Califorms-8B	412,263.87	1.65	16.17	18.69	1.85	2.12	8,957.16	1.43	0.18	34,561.80	5.50	0.52
Califorms-4B	370,972.35	2.42	17.95	6.80	49.38	11.00	9,770.04	1.92	0.21	35,775.36	5.99	0.68
Califorms-1B	356,694.82	1.98	16.00	2.69	22.22	1.06	10,223.28	1.94	0.22	35,958.24	5.99	0.67