

Cumulus: Blockchain-Enabled Privacy Preserving Data Audit in Cloud

PRABAL BANERJEE, Avail and Indian Statistical Institute, India

NISHANT NIKAM

SUBHRA MAZUMDAR, TU Wien and Christian Doppler Laboratory Blockchain Technologies for the IoT, Austria

SUSHMITA RUJ, University of New South Wales, Australia

Data owners upload large files to cloud storage servers, but malicious servers may potentially tamper data. To check integrity of remote data, Proof of Retrieval (PoR) schemes were introduced. Existing PoR protocols assume that data owners and third-party auditors are honest and audit only the potentially malicious cloud server to check integrity of stored data. In this paper we consider a system where any party may attempt to cheat others and consider collusion cases. We design a protocol, Cumulus¹, that is secure under such adversarial assumptions and use blockchain smart contracts to act as mediator in case of dispute and payment settlement. We use state channels to reduce blockchain interactions in order to build a practical audit solution. The security of the protocol has been proven in Universal Composability (UC) framework. Finally, we illustrate several applications of our basic protocol and evaluate practicality of our approach via a prototype implementation for fairly selling large files over the cryptocurrency Ethereum. We implement and evaluate a prototype using Ethereum as the blockchain platform and show that our scheme has comparable performance.

CCS Concepts: • **Security and privacy** → **Privacy-preserving protocols**.

Additional Key Words and Phrases: PoR, Cloud, Storage, Audit, Blockchain, DLT, Privacy

1 INTRODUCTION

Recent years have seen enormous amount of data generated and people using multiple devices connected to the Internet. To cater to the need for accessing data across devices, cloud storage providers have come up. Similarly, there has been an increase in Anything-as-a-Service(XaaS) which needs data to be uploaded and stored on remote servers. To ensure integrity of uploaded data, Proof-of-Storage algorithms have been proposed. With publicly verifiable Proof-of-Retrieval schemes, data owners can potentially outsource this auditing task to third-party auditors who send challenges to storage servers. The storage servers compute responses for each challenge and gives a response. By validating the challenge-response pair, the auditor ensures that the stored file is intact and retrievable.

The inherent assumption in the existing PoR schemes is that the data owner is always honest. The server may be malicious and try to erase data in an attempt to reduce its cost. The PoR schemes offer guarantees that if the server responds correctly to the challenge set, then the file is recoverable with overwhelming probability. The auditor is trusted with checking the integrity of the stored data without gaining access to the data itself, but previous studies showed that the auditor might gain access by carefully selecting the challenge set it sends to the server, thus acting maliciously. Also, data owner may refuse payment to server and auditor in a bid to cut cost and act maliciously.

Blockchain, a distributed tamper-resistant ledger, has seen several use cases lately. With smart contract support, arbitrary logic can be enforced in a distributed manner, even in the presence of some malicious players. These abilities are used to make blockchain a trusted party to resolve disputes. Several works have used blockchain as a judge to settle disputes among involved parties [8, 17, 26]. Most major blockchain platforms have an inherent currency which is used

¹Cloud storage has no relation to clouds in the sky! But since this type of cloud indicates fair weather, often popping up on bright sunny days, we chose this name to illustrate that our protocol would make the future of cloud storage brighter

Authors' addresses: Prabal Banerjee, mail.prabal@gmail.com, Avail and Indian Statistical Institute, Kolkata, West Bengal, India; Nishant Nikam, nikam_nishant@outlook.com; Subhra Mazumdar, TU Wien and Christian Doppler Laboratory Blockchain Technologies for the IoT, Vienna, Austria, subhra.mazumdar@tuwien.ac.at; Sushmita Ruj, University of New South Wales, Sydney, Australia, sushmita.ruj@unsw.edu.au.

to make meaningful monetary contracts among participants. Our objective in this paper is to address the problems discussed above, without having any trust assumptions. The proposed solution must be either efficient or comparable to the state-of-the-art.

1.1 Our Contribution

In this paper we aim to propose a blockchain based proof-of-storage model and prove its security even if data owner is corrupted. We study the collusion cases and argue that our system is secure unless the data owner, auditor and cloud server together collude and act maliciously. We implement a prototype using a modified version of Ethereum. We use the inherent currency of the blockchain platform to model and enforce our incentive structure. To make minimum blockchain interactions, we use state channels and perform off-chain transactions. Our experiments show that our improved system has comparable performance. We summarize the contribution as follows:

- We propose a blockchain based data audit model, *Cumulus*, where the auditor can be a third party.
- We design state channel based audit protocol to minimize blockchain commits.
- We use blockchain-based payment to incentivize players in the system.
- We prove the security of our protocol in the *UC* framework and show that the scheme is resilient to any form of collusion between participating entities.
- We implement a prototype on modified Ethereum and show comparable performance with overhead of around 6 seconds per audit phase.

2 PRELIMINARIES AND BACKGROUND

2.1 Notations

We take λ to be the security parameter. An algorithm $\mathcal{A}(1^\lambda)$ is a probabilistic polynomial-time algorithm when its running time is polynomial in λ and its output y is a random variable which depends on the internal coin tosses of \mathcal{A} . A function $f : \mathbb{N} \rightarrow \mathbb{R}$ is called negligible in λ if for all positive integers c and for all sufficiently large λ , we have $f(\lambda) < \frac{1}{\lambda^c}$. An element a chosen uniformly at random from set \mathcal{S} is denoted as $a \xleftarrow{R} \mathcal{S}$. We use a secure digital signature algorithm $(\text{Gen}, \text{Sign}, \text{SigVerify})$, where $\text{Gen}()$ is the key generation algorithm, $\text{Sign}()$ is the signing algorithm and $\text{SigVerify}()$ is the signature verification algorithm. We use a collision-resistant cryptographic hash function H .

2.2 Bilinear Pairings

Definition: Let G_1, G_2 be two additive cyclic groups of prime order p , and G_T another cyclic group of order p written multiplicatively. A pairing is a map $e : G_1 \times G_2 \rightarrow G_T$, which satisfies the following properties:

- **Bilinearity:** $\forall a, b \in \mathbb{Z}_p^*, \forall P \in G_1, \forall Q \in G_2 :$

$$e(aP, bQ) = e(P, Q)^{ab}$$

where $\mathbb{Z}_p^* = \{1 \leq a \leq p-1 : \gcd(a, p) = 1\}$ with group operation of multiplication modulo p .

- **Non-Degeneracy:** $e(g_1, g_2) \neq 1_G$ where g_1 and g_2 are generators of G_1 and G_2 respectively and 1_G is the identity element in G_T .
- **Computability:** There exists an efficient algorithm to compute e .

A pairing is called symmetric if $G_1 = G_2$. When we use symmetric bilinear pairings, we refer to a map of the form $e : G \times G \rightarrow G_T$ with group G 's support being \mathbb{Z}_p . [22]

2.3 Proofs of Retrievability

PoR schemes are used to guarantee a client that her uploaded data stored with the server is not tampered. It was first introduced by Juels and Kaliski [25]. In the setup phase, the client encodes file with erasure codes to get preprocessed file F , where each block of file m_i is an element in \mathbb{Z}_p . It computes authenticator tags σ_i for each block of F and uploads F to server along with the authenticators. During audit phase, the client sends random challenges to the server which acts as the prover and responds with a proof. The client verifies the proof and the server passes the audit if the verification goes through.

The correctness of the PoR algorithm ensures that an honest server always passes an audit, i.e., the challenge-response pair verification outputs 1. The soundness property ensures that F can be retrieved from a server which passes the audits with non-negligible probability.

There are mainly two types of PoR schemes: privately verifiable and publicly verifiable. In privately verifiable schemes, the client herself audits the server, or the auditor knows secret about the data. In publicly verifiable PoR schemes, any third party auditor can generate challenges and verify responses by knowing public parameters of the client. A PoR scheme is called privacy preserving if the responses to a challenge does not reveal any knowledge about the data.

2.4 File Processing and Query Generation

File: A file F is broken into n chunks, where each chunk is one element of \mathbb{Z}_p . Let the file be b bits long. We refer to each file chunk as m_i where $1 \leq i \leq n$ and $n = \lceil b/\lg p \rceil$. We use chunk and block interchangeably to refer to each file chunk.

Query: $Q = \{(i, v_i)\}$ be an l -element set, where l is a system parameter, $1 \leq i \leq n$ and $v_i \in \mathbb{Z}_p$. The verifier chooses an l -element subset l of $[1, n]$, uniformly at random. For each $i \in I$, $v_i \xleftarrow{R} \mathbb{Z}_p$.

2.5 Shacham Waters Public Verifiability Scheme

We use the Shacham and Waters Compact Proofs of Retrievability scheme with public verifiability [46], which uses symmetric bilinear pairings. Let a user have a key pair $K = (sk, pk)$ where $sk = x \in \mathbb{Z}_p$ and $pk = v = g^x \in G$. Let $u \in G$ be a generator. For file block i , authentication tag $\sigma_i = [H(i)u^{m_i}]^{sk}$. The prover receives the query $Q = \{(i, v_i)\}$ and sends back $\sigma \leftarrow \prod_{(i, v_i) \in Q} \sigma_i^{v_i}$ and $\mu \leftarrow \sum_{(i, v_i) \in Q} v_i \cdot m_i$. The verification equation is :

$$e(\sigma, g) \stackrel{?}{=} e\left(\prod_{(i, v_i) \in Q} H(i)^{v_i} \cdot u^\mu, v\right) \quad (1)$$

The scheme has public verifiability because to generate authentication tags the private key sk is required. On the other hand, for the proof-of-retrievability protocol, public key pk is sufficient. In this paper, we refer to this scheme as Shacham-Waters.

2.6 Privacy Preserving Public Auditing for Secure Cloud Storage

To achieve strong privacy guarantees, we use Privacy Preserving Public Auditing for Secure Cloud Storage scheme by Wang *et al.* [52]. Let $H_1 : \{0, 1\}^* \rightarrow G_1$ and $H_2 : G_T \rightarrow \mathbb{Z}_p$ be hash functions and g be a generator of G_2 . Let a user have a key pair $K = (sk, pk)$ where $sk = x \in \mathbb{Z}_p$ and $pk = (v, g, u, e(u, v))$ such that $v = g^x$ and $u \xleftarrow{R} G_1$. For file block i with identifier $id \xleftarrow{R} \mathbb{Z}_p$, authentication tag $\sigma_i = [H_1(W_i)u^{m_i}]^{sk}$, where $W_i = id||i$. The prover receives the query $Q = \{(i, v_i)\}$. It selects a random element $r \xleftarrow{R} \mathbb{Z}_p$ and calculates $R = e(u, v)^r$ along with $\gamma = H_2(R)$. Finally the prover sends back (μ, σ, R) where $\sigma \leftarrow \prod_{(i, v_i) \in Q} \sigma_i^{v_i}$ and $\mu \leftarrow r + \gamma \times (\sum_{(i, v_i) \in Q} v_i \cdot m_i)$. The verification equation is :

$$R \cdot e(\sigma^\gamma, g) \stackrel{?}{=} e\left(\prod_{(i, v_i) \in Q} H_1(W_i)^{v_i} \cdot u^\mu, v\right) \quad (2)$$

The scheme is also publicly verifiable like Shacham-Waters protocol. Additionally, it is privacy preserving. In this paper, we refer to this scheme as PPSCS.

2.7 Blockchain

Blockchain is a tamper-resistant, append-only distributed ledger. Apart from acting as a non-repudiable log, blockchain can host distributed applications and perform arbitrary functions in the form of smart contracts. First introduced in Bitcoin [43], it is a hash-linked chain of blocks, each block potentially containing multiple transactions. Participating nodes broadcast ledger updates in form of transactions. While there are various flavours of blockchain systems present based on the type of consensus protocol they use, we use a Proof-of-Work(PoW) based blockchain system. In a blockchain platform following PoW consensus protocol, special nodes, called miners, form blocks containing multiple transactions. The miners compete and solve a hash based challenge and the winner gets to propose the next block along with getting a mining reward.

Ethereum [57] is one of the most popular blockchain platforms supporting Turing-complete languages to write smart contracts. Ether is the cryptocurrency of the Ethereum platform and it is used to incentivize computations on the platform. The contracts are executed inside Ethereum Virtual Machine(EVM) which is uniform across all nodes, so as to have same output across the network. The amount of work done in terms of the number of operations done is calculated in terms of gas. A user submits transactions along with ethers to compensate for the work done by miners, according to the gas price. This acts as a transaction fee for the miners, and at the same time prevents running bad code like infinite loops which might harm the miners. Ethereum has a set of pre-compiled contracts which are codes running inside the host machine and not inside the EVM. Hence, the pre-compiled contracts cost less gas. Ethereum is open-source with an active community and has seen large scale adoption.

While active research is being performed to lower consensus time in public blockchain systems, traditional PoW chains need considerable time before a transaction reaches finality. Hence, it becomes hard to implement multi-commit protocols which are practical. For example, in Ethereum, the average block generation time is between 10-19 seconds. This delay might not be suitable for high frequency applications. On top of that, for each transaction to get mined, the user needs to incur additional cost in terms of transaction fee or gas costs. These problems make protocols like audit unsuitable as an auditor and server need to interact multiple times to exchange challenges and responses. A typical technique used to bypass these problems is performing off-chain transactions by opening state channels between pairs of users. The participants of a state channel exchange signed messages and perform on-chain transactions only when

either they are finished with their interaction or some dispute arises. The blockchain either saves the final states of the participants or resolves disputes, whichever applicable. This reduces time and cost for the users.

3 RELATED WORK

On Cloud Storage: The idea of auditing cloud storage servers was first introduced by Ateniese *et al.*[4], who defined Provable Data Possession (PDP) model. Juels and Kaliski [25] first described a PoR scheme for static data using sentinels. A similar construction was provided by Naor *et al.* [37] using MAC-based authenticators. A study on various variants of PoR schemes with private verifiability is done by Dodis *et al.*[15]. First fully dynamic provable data possession was given by Erway *et al.*[19]. A secure distributed cloud storage scheme called HAIL (high-availability and integrity layer) is proposed by Bowers *et al.*[10] which attains POR guarantees. Shacham and Waters provided a PoR construction using BLS signatures, which had both public and private verifiability. Wang *et al.* argued that the auditor can retrieve information about files and hence proposed a privacy-preserving data audit scheme in [52]. For dynamic data, an ORAM-based audit protocol was given in [13]. More efficient protocols were given in [14, 21, 28, 42, 44, 45, 54, 55]. Multiple server-based PoR schemes were formalized in [41]. Multi-user based data integrity check with revocable user access was proposed in [48]. An identity-based auditing scheme for medical data was proposed in [60]. Nayak and Tripathy [38] came up with a protocol that guarantees a secure and efficient privacy-preserving provable data possession scheme (SEPDP) for cloud storage and extended it to support multiple data owners, batch auditing, and dynamic data operations. Their scheme fails to guarantee soundness and does not achieve zero-knowledge privacy. Ni *et al.* [39] addressed this issue by proposing an IDentity-based Privacy-Preserving Provable Data Possession scheme (ID-P3DP) based on the RSA assumption for secure cloud storage. It supports data privacy preservation against third-party auditors and multi-user aggregate verification. Yang *et al.* [61] propose an ID-based PDP with compressed cloud storage where cloud storage auditing can be achieved by using only encrypted data blocks in a self-verified way and original data blocks can be reconstructed from the outsourced data.

In OPOR[2], the authors define a formal framework where the auditing task is outsourced and provide a construction based on Shacham-Waters. Although it talks about handling all possible collusion cases, the scheme is shown to be secure for arbitrary collusion in terms of file recovery and not reliability, i.e., a misbehaving auditor may be able to prove innocence if it colludes with a malicious data owner. Also, in OPOR, the file is assumed to be encrypted and uploaded by the data owner to the server as the scheme does not ensure the privacy of the file. It also fails to provide a payment mechanism or arbitration. For multi-user owned data integrity check, Yuan *et al.* [62] proposed a scheme that handled collusion between parties, but was shown to be flawed in [65]. In our paper, we provide an end-to-end system that handles data privacy, payment, and arbitration and is resilient to arbitrary collusion between parties.

Auditing using Blockchain: Wang *et al.* [53] proposed the notion of Non-Interactive Public Provable Data Possession (NI-PPDP) and designed a blockchain-based fair payment smart contract for cloud storage based on this primitive. However, this work still suffers from some limitations that it is not easy to trace the malicious participant and works if the cloud service provider does not collude with the auditor. Yue *et al.* [63] proposed a framework for decentralized Edge-Cloud Storage. Efficient verification is ensured by sampling verification and formulated rational sampling strategies. However, this work does not have any incentive mechanisms, and the computational cost and the communication cost cannot be evaluated. A blockchain-based efficient public integrity auditing scheme to resist misbehaved third-party auditor is proposed in [31]. Here the user is required to check the behaviors of auditors for a longer duration compared with that of the data integrity auditing performed by the auditor. The protocol fails to work in the presence of a fully malicious cloud server. Zhang *et al.* [64] used the blockchain to record the interactions among users, service providers,

and organizers in the data auditing process as evidence. Moreover, the smart contract was employed to detect service disputes. Xie et al. [58] use smart contracts to improve the reliability and stability of audit results. However, the authors assume that the data owner is a trusted entity. In [27], the authors proposed a privacy-preserving auditable service with traceable timeliness for public cloud Storage. However, it is assumed that the data owner does not collude with the cloud service provider. Additionally, the scheme works if the auditor does not collude with the data owner and the cloud.

On Storage with Blockchain: In recent times, various blockchain-based cloud servers have come up. IPFS[6] introduced a blockchain-based naming and storage system. Several other systems [1, 51, 56] use the concept of cloud storage in a decentralized fashion in a P2P network. In [3], the authors make the storage accountable and show how to integrate with Bitcoin. In [7], the designers use IPFS and cryptocurrency to make a storage-based marketplace. They use Proof of Replication to enforce storage among their peers. SpaceMint[40] introduced a new cryptocurrency that adapts proof of space, and also proposed a different blockchain format and transaction types. Moran *et al.*[36] introduced Proofs of Space-Time (PoSTs) and implemented a practical protocol for these proofs. An in-depth analysis of Proof of Replication mechanisms was done in [20]. While the use of blockchain as an enforcer and incentive distribution mechanism was tapped in these works, most works did not consider fairness among the services offered by the parties. IntegrityChain, a decentralized storage framework supporting provable data possession (PDP) based on blockchain was proposed in [32]. Fairness in trading is ensured as a party loses coins upon misbehaving and earns if it behaves honestly.

Several works use deduplication technology by performing auditing on one copy of multiple same data, thereby significantly reducing storage overhead. In [59], a client-side data deduplication scheme based on bilinear-pair techniques has been proposed. Blockchain records the behaviors of entities in both data outsourcing and auditing processes, ensuring the credibility of audit results. The paper lacks a discussion on fairness. Tian et al. [49] proposed a blockchain-based secure deduplication scheme in decentralized storage. The scheme is based on the double-server storage model to achieve efficient space-saving while protecting data users from losing data under a single point of failure and duplicate-faking attack. Transparent integrity auditing was introduced in [30] based on the blockchain. The authors have constructed a secure transparent deduplication scheme that supports deduplication over encrypted data. Li et al. [29] proposed a secure transparent deduplication scheme based on the blockchain that supports deduplication over encrypted data and enables users to attest the deduplication pattern on the cloud server. Another paper [47] discusses a scheme that bridges secure deduplication and integrity auditing in encrypted cloud storage. However, all these works consider the cloud server to be semi-trusted or the third-party auditor to be trusted. In [35], a blockchain-based secure decentralized public auditing in decentralized cloud storage has been proposed. The authors have used redactability for blockchain to handle security issues. Additionally, the model uses an efficient deduplication scheme to attain adequate storage savings while preserving the users from data loss due to duplicate faking attacks. Liu et al. [33] propose a blockchain-based compact audit-enabled deduplication scheme in decentralized storage. The protocol adopts an aggregatable vector commitment to generate audit tags to overcome the low coupling problem between deduplication and auditing. The drawback of the protocol is that it considers the storage service provider to be honest-but-curious and does not work if the party is malicious.

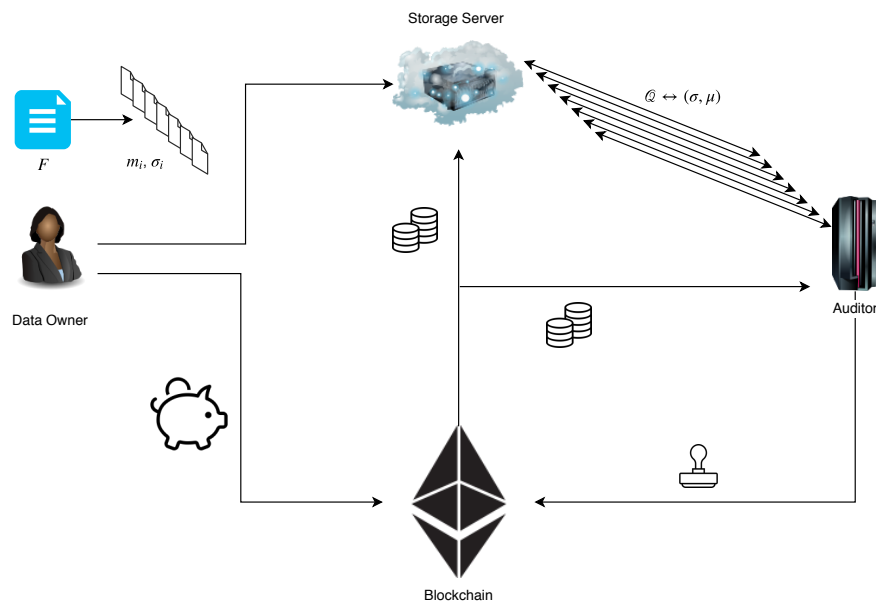

Fig. 1. Overview of Interactions between Parties

4 PROTOCOL OVERVIEW

In this section we give an overview of the protocol and outline the deliverables we seek out of it. Figure 1 provides an outline of our protocol.

4.1 System Model

The protocol has three entities: *data owner*, *cloud storage server* and *auditor*. We use the blockchain layer as an arbitrator in case of disputes, using the Turing-complete capability of the blockchain platform to codify the actions in case of dispute. The native currency of the platform is used to distribute and control incentives. The immutability of the blockchain helps keep log of audit results and provides a transparent infrastructure without sacrificing on privacy. We assume that the *data owner* sets up the smart contract and the *cloud server* and *auditor* interact only if they agree to the terms of the contract. If using a permissionless blockchain, any entity can run the blockchain network and the smart contract can be deployed on it. In case a private blockchain network is used, we think the storage providers, auditors and data owners will participate in the blockchain. The work done by the participants are incentivized in terms of gas cost and hence there might be entities who participate in the network just to gain that incentive.

4.2 Adversarial Model & Assumptions

We would call a user honest, if she follows the protocol. Otherwise, we would call her malicious. A malicious user can deviate arbitrarily.

An adversary is a polynomial-time algorithm that can make any user malicious at any point of time, subject to some upper bound. Our adversary is dynamic in nature, that is, it can select its target based on current configuration of the

system. It can make coordinated attacks, that is, it can control the malicious users and send/receive messages on their behalf. It can, of course, make a malicious user isolated and prescribe arbitrary instructions for her to perform. [23]

However, the adversary cannot break cryptographic primitives like hash functions or signatures, except with negligible probability. It cannot interfere with honest users or their exchanges. Apart from this, we make the following assumptions:

- (i) Among the peers in the blockchain, the adversary can only corrupt upto the bound of the underlying consensus protocol. For example, in PoW based blockchains the bound is 49%, and for PoS based blockchains the bound is 33%.
- (ii) The three parties apart from the blockchain - owner, server and auditor - cannot be corrupted together. At most two of the three parties can be malicious at any point of time.
- (iii) We assume that the adversary will not corrupt without sufficient incentive. We think of the adversary as a rational adversary.

4.3 Security Goals

We define the security goals that must be realized by *Cumulus*.

- **Authenticity:** The authenticity of storage requires that the cloud server cannot forge a valid proof of storage corresponding to the challenge set Q without storing the challenged chunks and their respective authentication tags untampered, except with a probability negligible in λ .
- **Extractibility:** The extractibility property requires the `FetchFile()` function to be able to recover the original file when interacting with a prover that correctly computes responses for non-negligible fraction of the query space.
- **Privacy:** The privacy of audit requires the auditor not to learn any property of the stored file chunks m_i . The auditor generates queries to receive response. The auditor should not be able to derive m_i , for any i , from the response.
- **Fairness:** We notice that the cloud server and auditor offer services in exchange for payment from the data owner. The fairness property would require the following :
 - If the cloud server stores $m_i, \forall i$, then it receives adequate incentive. If it fails to keep the files intact, it gets penalized.
 - If the auditor generates queries correctly, verifies responses and submits aggregated response to blockchain, then it receives an appropriate incentive. If not, it gets penalized.
 - If the data owner gets services from cloud server and auditor as intended, then it has to pay according to the agreement. If she incurs losses due to a malicious party, she will be paid for the damage.

4.4 Protocol Phases

We break our protocol into four different phases. Let us outline the details of each of these phases.

Phase 0: Initialization Phase

- **KeyGen:** Initialized by the data owner, this algorithm generates a random public-private key-pair $K = (sk, pk)$ and public parameters based on the security parameter λ .
- **RegisterOwner:** A new data owner uses this function to setup her account. She deposits prerequisite money to initialize her account with, which is used for future payments. The identity information, owner ID, will be used to authorize all further transactions by this data owner. She also submits her public key pk_o which is used to verify signed messages submitted by the owner.

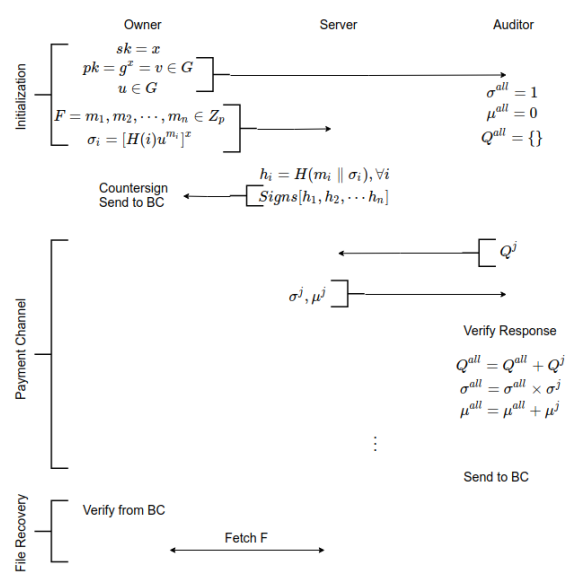

(a) Flow of the Protocol in AuB

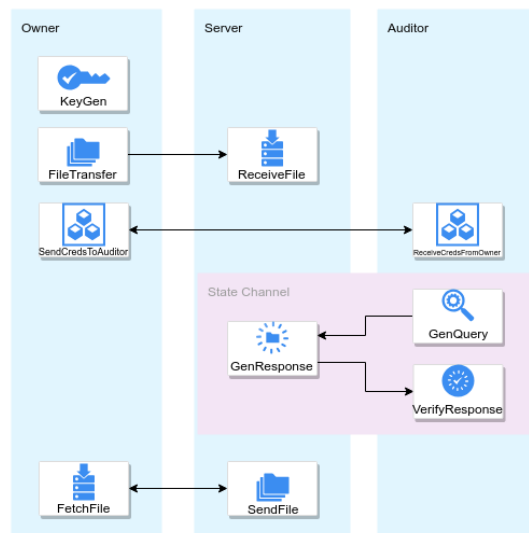

(b) Generic Data Flow of the Protocol

Fig. 2. Construction Overview

- **RegisterServer:** An existing data owner uses this function to supply identity information about the publicly known server, serverID, and public key pk_s of the server with whom she wants to store her data.

- **RegisterAuditor:** This function is called by the operative data owner to specify the publicly known auditor, auditorID, she wants to assign. If the owner wants the selected auditor to only audit a particular server, the owner may additionally supply that information.

Phase 1: Owner - Server

- **FileTransfer:** The owner divides the file F into n blocks. Let $F = m_1, m_2, \dots, m_n \in \mathbb{Z}_p$. She generates authentication tags, $\sigma_i, 1 \leq i \leq n$ and calculates hash $h_i = H(m_i \parallel \sigma_i)$ for $1 \leq i \leq n$. She sends $(m_i, \sigma_i), \forall i$, to the server. She receives $([h'_1, h'_2, \dots, h'_n], t)$ from server, where t is the signature tag. She checks $\text{SigVerify}([h'_1, h'_2, \dots, h'_n], t, pk_s) = 1$ and $h_i = h'_i (\forall i)$. Then, she sends $\text{Sign}([h'_1, h'_2, \dots, h'_n], t, sk_o)$ to the blockchain.

Phase 2: Server - Auditor

- **OpenChannel:** This function Collects deposit from server and auditor and opens up a state channel between them to interact off-chain. It freezes the owner money to pay necessary parties once channel is closed.
- **GenQuery:** This function generates an audit query for the auditor based on the randomness derived from the last block of the blockchain. The query is then sent to the server for response.
- **GenResponse:** Given a query, this function generates an audit response. The server sends the response to the auditor.
- **Verify:** Given a response, this function verifies whether the response is correct or not. Based on this outcome of verification, we proceed with the next set of challenges.
- **CloseChannel:** This function receives aggregated challenge-response along with the complaint, if any. It verifies whether the queries were valid and responses pass the audit. In case of complaint, it punishes the guilty party, else, it pays server and auditor as per norms of payment.

Phase 3: Owner - Server

- **FetchFile:** The data owner retrieves the stored file from the server using this function.

For a protocol to fit into our framework, the PoR scheme has to be publicly verifiable and needs to produce short aggregated proofs. Although multiple PoR schemes have our required properties, we chose Shacham-Waters in our first protocol named *Audit using Blockchain(AuB)*. Shacham-Waters have complete security proofs along with practical overhead in terms of implementation. Also, it uses Homomorphic Linear Authenticators (HLA) which helps us have a very concise proof, which can be submitted to the ledger for verification upon closing state channel. The major drawback of Shacham-Waters is that it lacks privacy. Attacks have been shown that reveal parts of data from audit proofs. Hence, we further define a privacy preserving audit scheme using blockchain named *Privacy Preserving Audit using Blockchain(PPAuB)* using PPSCS which gives privacy guarantees by random masking. We discuss the designs of *AuB* and *PPAuB* in this section. Figure 2b provides a generic overview of the data flow in our construction.

We assume that the server and auditor are known entities in the system, i.e., their public keys, identities and addresses are known throughout the system. Also, we assume the server and auditor has some coins deposited in the system which can be used to penalize them in case of misbehavior. For simplicity, we assume a single file F uploaded by a single owner O to server S . We assume O authorizes auditor Au as the third-party auditor for performing audits. O might as well act as Au herself and perform the audit protocol. Our security assumptions allow such a case because the protocol is resilient against collusion by owner and auditor.

5 OUR SECURITY MODEL

In this section, we model the security properties of *Cumulus* in the global Universally Composable (UC) framework [12] and discuss the security guarantee of our proposed protocol in this framework. We assume the set of parties involved in the protocol is fixed and the public keys of all parties are known. For our protocol, we consider static corruption where a PPT (probabilistic polynomial time) adversary \mathcal{A} can corrupt any party at the beginning of the protocol. Once a party is corrupted, \mathcal{A} can read the internal state, as well as all of the incoming and outgoing messages, of that party.

We analyze the security of *Cumulus* in the real world and simulates its execution in an ideal world. We define an ideal functionality that acts like a trusted party and all the parties interact with the ideal functionality. The ideal functionality is like an abstraction of our proposed protocol where we prove the security properties realized by our protocol. We also define an ideal world adversary, *Sim*, that attacks the ideal world functionality in the same way like the adversary \mathcal{A} attacks the protocol execution in the real world. We also define a PPT environment \mathcal{Z} that sends and receives information in both the real and ideal world. Our protocol is UC-secure if the environment \mathcal{Z} can distinguish its interaction with the real world and ideal world with negligible probability. We discuss next the communication model, the global ledger functionality \mathcal{L} , and the global random oracle before describing the ideal functionality $\mathcal{F}_{\text{Audit}}^{\mathcal{L}}$ for file integrity audit.

Communication Model

It is assumed that the communication between parties happen in a synchronized fashion, with protocol execution taking place in rounds. All honest parties are assumed to follow an ideal global clock $\mathcal{G}_{\text{clock}}$ [5] which keep tracks of the time of each round. Offline communication between honest parties is assumed to occur via ideal functionality \mathcal{F}_{smt} , which ensures secure message transmission. Message send by party P at round t reaches party Q at $t + 1$. An adversary gets to know when the message is being sent out but doesn't get to know the content of the message. Messages exchanged between parties and environment \mathcal{Z} or parties and the adversary is assumed to take 0 rounds for transmission.

Global random oracles

We will use a global random oracle \mathcal{H} [17] which is accessible by several instances of the protocol. It is like a log file, where given an input, an output is randomly generated. If the oracle is queried more than once on the same input, it returns the same output without regenerating one.

Global Ledger Functionality

We define a ledger functionality \mathcal{L} that captures the basic functionality of transferring coins between parties and also locking and unlocking coins from a smart contract [18]. We assume that \mathcal{L} has access to the global random oracle \mathcal{H} . The ledger functionality is used both in the real and ideal world and can be accessed by multiple instances of the protocol, hence it is called the global ideal functionality [17].

We define \mathcal{L} in Fig.3 as stated in [17]. A list L is maintained that keeps track of the coins locked in the contract denoted by contract identifier id . The *update* function maintains the balance of each party P_i in the local list L . Any party P_i present in the instantiation of the contract id , locks coins in the contract by calling module *freeze*. If the balance of party P_i in L is more than 0, then the coins can be frozen in the contract. Else, an error *no balance* is returned. Upon calling the module *unfreeze*, the parties can unlock their locked coins from contract id . Upon querying the latest state

of \mathcal{L} , the global random oracle \mathcal{H} is called with L as the input. Basically, this value acts as the *seed* which is used by the auditor in generating queries for the contract id .

Functionality \mathcal{L} , running with a set of parties $\mathcal{P}_1, \dots, \mathcal{P}_n$ stores the balance $p_i \in \mathbb{N}$ for every party $p_i, i \in [n]$ and a partial function L for frozen cash. It accepts queries of the following types:

- **Update Funds** Upon receiving message $(update, \mathcal{P}_i, p)$ with $p \geq 0$ from \mathcal{Z} set $p_i = p$ and send $(updated, \mathcal{P}_i, p)$ to every entity.
- **Freeze Funds** Upon receiving message $(freeze, \mathcal{P}_i, p)$ from an ideal functionality of session id check if $p_i > p$. If this is not the case, reply with $(nofunds, \mathcal{P}_i, p)$. Otherwise set $p_i = p_i - p$, store (id, p) in L and send $(frozen, id, \mathcal{P}_i, p)$ to every entity.
- **Unfreeze Funds** Upon receiving message $(unfreeze, id, \mathcal{P}_j, p)$ from an ideal functionality of session id , check if $(id, p') \in L$ with $p' \geq p$. If this check holds update (id, p') to $(id; p' - p)$, set $p_j = p_j + p$ and send $(unfrozen, id, \mathcal{P}_j, p)$ to every entity.
- **Latest State** Upon receiving message (get_latest_state, id) from an ideal functionality of session id , call the global random oracle \mathcal{H} on input L , and return $\mathcal{H}(L)$.

Fig. 3. Global ledger functionality \mathcal{L}

Ideal functionality for file integrity audit

The ideal functionality $\mathcal{F}_{\text{Audit}}^{\mathcal{L}}$ shows how a file owner O shares a file with a cloud server S , and later entrusts an auditor Au with the task of guaranteeing that the server has stored the file without deleting or modifying it and O can retrieve it later as well.

$\mathcal{F}_{\text{Audit}}^{\mathcal{L}}$ has four phases as defined in Fig. 4: in the *initialize* phase, the file is transferred from O to server S and, O locks coins $p_S + p_{Au}$ in the ledger \mathcal{L} . p_S and p_{Au} are the coins to be paid to S and Au upon successful completion of service. In the *channel open* phase, the auditor initiates the opening of a payment channel by sending a request to the server. The purpose of the payment channel is to ensure off-chain auditing of files and make a promise of payment if the audit is successful. If the server does not agree to open the channel, then coins locked by O are refunded. If both Au and S are willing to open the channel, then they individually lock coins a and b respectively in the channel where $a < p_{Au}$ and $b < p_S$. If Au (or S), misbehaves then it will lose a (or b) coins and the coins will be used for compensating O and S (or Au).

In the *query and response* phase, auditor sends a query Q . $\mathcal{F}_{\text{Audit}}^{\mathcal{L}}$ checks if Q is generated from *seed*. It retrieves the seed by querying \mathcal{L} for latest state. If the Q is an invalid one, Au is penalized. Else, $\mathcal{F}_{\text{Audit}}^{\mathcal{L}}$ waits for a response from S . If the latter sends abort, then it means that S cannot answer the query and hence it loses b coins. If the response is correct, then nothing is done. If the response is wrong, then S is penalized. If after receiving the response, Au sends abort, then a coins are used for compensating the server and owner. In *channel close* phase, if Au sends abort, it means that it had colluded with S and trying to send a wrong query-response set and hence, Au is penalized. If this is not the case, then $\mathcal{F}_{\text{Audit}}^{\mathcal{L}}$ checks if the number of queries made is at least the *query_count*. If this holds, Au receives p_{Au} coins and S receives p_S coins, marking the successful completion of file auditing. If the number of queries generated is less than the threshold, then Au is penalized.

Privacy and Security Properties

We discuss how the ideal functionality $\mathcal{F}_{\text{Audit}}^{\mathcal{L}}$ guarantees the following privacy and security properties:

The ideal functionality $\mathcal{F}_{\text{Audit}}^{\mathcal{L}}$ (in session id) interacts with an owner \mathcal{O} , a server \mathcal{S} , an auditor Au , the ideal adversary Sim and the global ledger \mathcal{L} . Variables used: $channel = \phi$.

(Initialize)

- Upon receiving $(store, id, F, p_S, p_{Au}, query_count, n, id_{Au}, id_S)$ from \mathcal{Z} , leak $(store, id, |F|, query_count, n, p_S, p_{Au}, id_O, id_S, id_{Au})$ to Sim . Store F as file chunks $m_i, \forall i \in [1, n]$ and store $query_count$.
- Send $(send, id, F, n, id_S)$ and $(auth, id)$ to \mathcal{Z} . If $(abort, id)$ is received from id_{S^*} , then terminate the protocol.
- Call \mathcal{L} with $(freeze, id, p_S + p_{Au}, id_O)$. \mathcal{L} returns $(frozen, id, p_S + p_{Au}, id_O)$ to $\mathcal{F}_{\text{Audit}}^{\mathcal{L}}$.

(Server-Auditor: Opening Channel)

- Upon receiving $(open_channel, id, a, id_S)$, forward the instruction to \mathcal{Z} . If $(open_channel, id, b, id_{Au})$ is received, leak the message of channel opening to Sim , call \mathcal{L} with $(freeze, id, a, id_{Au})$ and $(freeze, id, b, id_S)$. \mathcal{L} responds with $(frozen, id, a, id_{Au})$ and $(frozen, id, b, id_S)$. Set $channel = opened$, and leak $query_count$ to Sim . If S^* sends $(abort, id)$, call \mathcal{L} with $(unfreeze, id, p_S + p_{Au}, id_O)$ and abort.
- Send (get_latest_state, id) to \mathcal{L} , gets the value returned by \mathcal{L} , and stores the value in variable $seed$.

(Server-Auditor: Query and Response)

Upon receiving $(query, id, Q, id_{Au})$:

- Leak Q to Sim , forward the message to id_S . Check if Q can be generated from $seed$. If not, then call \mathcal{L} with $(unfreeze, id, b + \frac{a}{2}, id_S)$ and $(unfreeze, id, p_S + p_{Au} + \frac{a}{2}, id_O)$. Send $(penalized, id, id_{Au})$, set $channel = closed$ and abort.
- Upon receiving $(response, id, \bar{m}, id_S)$, construct set $\bar{m}' = \{m_i\}_{i \in Q \wedge m_i \in F}$, and check $\bar{m}' \stackrel{?}{=} \bar{m}$.
 - If this holds, then $Q_{all} = Q_{all} \cup Q$.
 - If $\bar{m}' \neq \bar{m}$, then call \mathcal{L} with $(unfreeze, id, \frac{b}{2} + a, id_{Au})$ and $(unfreeze, id, \frac{b}{2} + p_S + p_{Au}, id_O)$. Send $(penalized, id, id_S)$ to \mathcal{Z} , set $channel = closed$ and terminate the protocol.
 - If $(abort, id)$ is received from id_{Au^*} , then call \mathcal{L} with $(unfreeze, id, \frac{a}{2} + b, id_S)$ and $(unfreeze, id, \frac{a}{2} + p_S + p_{Au}, id_O)$. Send $(penalized, id, id_{Au})$ to \mathcal{Z} , set $channel = closed$ and terminate the protocol.
- If $(abort, id)$ is received from id_{S^*} , then call \mathcal{L} with $(unfreeze, id, \frac{b}{2} + a, id_{Au})$ and $(unfreeze, id, \frac{b}{2} + p_S + p_{Au}, id_O)$. Send $(penalized, id, id_S)$ to \mathcal{Z} , set $channel = closed$ and terminate the protocol.

(Server-Auditor: Close Channel)

- Upon receiving $(abort, id)$ from id_{Au^*} :
 - call \mathcal{L} with $(unfreeze, id, b + \frac{a}{2}, id_S)$ and $(unfreeze, id, p_S + p_{Au} + \frac{a}{2}, id_O)$. Send $(penalized, id, id_{Au})$ to \mathcal{Z} . Set $channel = closed$ and terminate.
- Upon receiving $(close, id, id_{Au})$:
 - Leak the instruction to Sim . Check $\frac{|Q_{all}|}{query_count} \stackrel{?}{\geq} 1$. If the inequality holds true, call \mathcal{L} with $(unfreeze, id, a + p_{Au}, id_{Au})$ and $(unfreeze, id, b + p_S, id_S)$, and send $(check_pass, id)$ to \mathcal{Z} . $\mathcal{F}_{\text{Audit}}^{\mathcal{L}}$ sends $(send_file, F, id_O)$, sets $channel = closed$ and terminate.
 - If the above step fails, call \mathcal{L} with $(unfreeze, id, b + \frac{a}{2}, id_S)$ and $(unfreeze, id, p_S + p_{Au} + \frac{a}{2}, id_O)$. Send $(penalized, id, id_{Au})$ to \mathcal{Z} . Set $channel = closed$ and terminate.

Fig. 4. Ideal Functionality $\mathcal{F}_{\text{Audit}}^{\mathcal{L}}$ for file integrity audit

- **Authenticity:** $\mathcal{F}_{\text{Audit}}^{\mathcal{L}}$ checks the response R corresponding to query Q and matches each response with the file chunks it had received from \mathcal{O} . If the response is wrong, \mathcal{S} is penalized.
- **Extractibility:** Since a threshold $query_count$ is set which is a significant fraction of total file size, if the auditing is successful, then \mathcal{O} is assured that with high confidence, it will receive the correct file from \mathcal{S} . If the number of queries is less than the threshold, Au is penalized by the ideal functionality.

- **Privacy:** Au does not come to know about the file content, it only sees whether the auditing was correct or not based on unfreezing of coins from \mathcal{L} .
- **Fairness:** If Au and S fails to open channel, coins are refunded to O . If auditor is malicious then $\mathcal{F}_{\text{Audit}}^{\mathcal{L}}$ penalizes the former and compensates O and S using a coins. If server is malicious, then $\mathcal{F}_{\text{Audit}}^{\mathcal{L}}$ penalizes S . If both Au and S behave as per the protocol specification, then both are rewarded.

6 FORMAL DESCRIPTION OF THE PROTOCOL

The protocol Π_{Cumulus} defined in the $(\mathcal{F}_{\text{ecdsa}}, \mathcal{G}_{\text{JC}}^{\mathcal{L}}, \mathcal{H})$ -hybrid world. We define judge contract functionality $\mathcal{G}_{\text{JC}}^{\mathcal{L}}$ before explaining the steps of the protocol. The ideal functionality $\mathcal{F}_{\text{ecdsa}}$ [16] is used for providing the interface of signing and verifying messages sends by the parties. Since ECDSA signatures are strongly existentially unforgeable [24], we leverage on this property to argue for the security of the *Cumulus*.

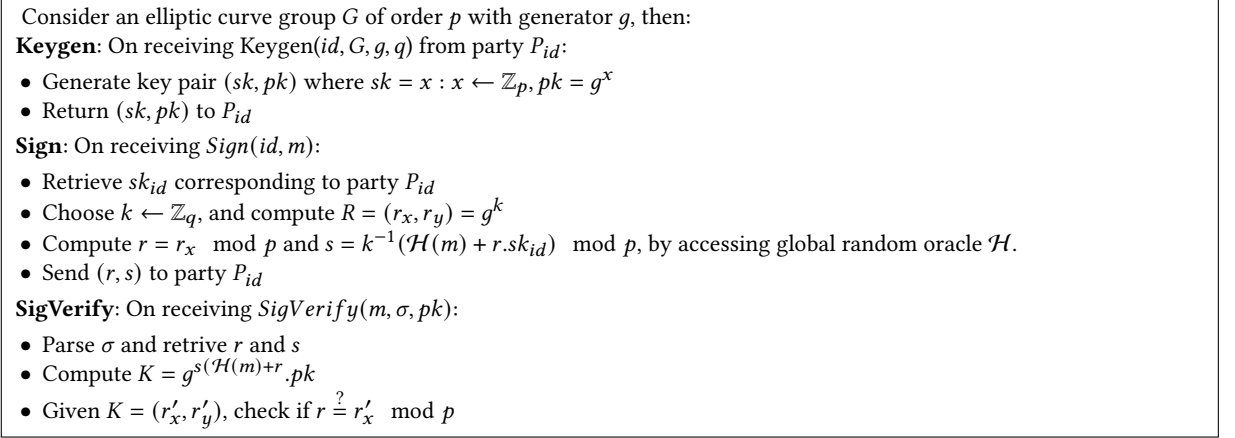

Fig. 5. Ideal Functionality $\mathcal{F}_{\text{ecdsa}}$ for ECDSA signature

The protocol Π_{Cumulus} interacts with an instance of the global ledger \mathcal{L} and the judge contract defined by ideal functionality $\mathcal{G}_{\text{JC}}^{\mathcal{L}}$. Any off-chain communication between any two honest parties occurs using ideal functionality for secure message transmission, \mathcal{F}_{smt} [12]. The protocol is defined in Fig.7. It calls the judge contract defined in Fig.6. We mention the difference in the steps of the protocol for the privacy-preserving version in Fig.9 and the corresponding changes in the judge contract in Fig. 8.

7 SECURITY ANALYSIS

We show that any attack that can be performed on our protocol can also be simulated on $\mathcal{F}_{\text{Audit}}^{\mathcal{L}}$, or in other words that our protocol is at least as secure as $\mathcal{F}_{\text{Audit}}^{\mathcal{L}}$. To prove this, we design a simulator Sim , that acts like an ideal attacker for the ideal functionality. We show that no PPT environment can distinguish between interacting with the real world and interacting with the ideal world. In the real world, the environment \mathcal{Z} sends instructions to a real attacker \mathcal{A} and interacts with our protocol. In the ideal world, \mathcal{Z} sends attack instructions to Sim and interacts with $\mathcal{F}_{\text{Audit}}^{\mathcal{L}}$.

UC Definition of security. Consider the protocol *Cumulus*, denoted as Π_C with access to the judge contract functionality $\mathcal{G}_{\text{JC}}^{\mathcal{L}}$, the global random oracle \mathcal{H} , ECDSA-signature functionality $\mathcal{F}_{\text{ecdsa}}$, and the global ledger functionality \mathcal{L} . Let

The ideal functionality $\mathcal{G}_{JC}^{\mathcal{L}}$ acts as a judge smart contract for session id id and interacts with the global \mathcal{L} functionality and the parties O , S and Au .

Function RegisterOwner($pk_o, contractTerms$):

| The Owner Deposits required money according to $contractTerms$. Return OwnerID to the Owner.

end

Function RegisterServer(OwnerID, ServerID):

| Store the mapping (OwnerID, ServerID)

end

Function RegisterAuditor(OwnerID, AuditorID):

| Store the mapping (OwnerID, AuditorID)

end

Function ReceiveSignedDigest($(m, t), s$):

| Require SigVerify(m, t, pk_s)=1 Require SigVerify($(m, t), s, pk_o$)=1

end

(Initialize)

- Upon receiving $(init, id, pk_o, pk_a, pk_s, u, v, g, contract\ terms, query_count, id_S, id_{Au})$, store the public keys pk_o, pk_s and pk_a , parameters v, u, g and $query_count$.
- Call RegisterOwner with input pk_o and $contract\ terms$. Get id_O .
- Call RegisterServer, with input id_O, id_S and RegisterAuditor, with input id_O, id_{Au} .
- Output $(initialized, registered\ id_O, registered\ id_S, registered\ id_{Au})$.

(File transfer from Owner to Server)

- Upon receiving $(verify, id, [h'_1, h'_2, \dots, h'_n], t, \sigma_{file})$ from O , call ReceiveSignedDigest with input $([h'_1, h'_2, \dots, h'_n], t, \sigma_{file})$. If the verification passes, return $verified$.

(Server-Auditor: Opening Channel)

- Upon receiving $(open_channel, id, a, id_{Au}, b, id_S)$ from Au , call \mathcal{L} with $(freeze, id, a, id_{Au})$ and $(freeze, id, b, id_S)$. \mathcal{L} responds with $(frozen, id, a, id_{Au})$ and $(frozen, id, b, id_S)$.
- Upon receiving acknowledgement from \mathcal{L} , return $(opened_channel, id)$.

(Server-Auditor: Closing Channel)

- Receive $(close, id, Q, sig_Q, (\mu, \sigma))$ from Au
 - Parse Q to get (i, v_i) , where i is the index of the chunk. Check $e(\sigma, g) \stackrel{?}{=} e(\prod_{(i, v_i) \in Q} H(i)^{v_i} u^\mu, v)$. If this holds true and $\frac{|Q|}{query_count} \geq 1$, call \mathcal{L} with $(unfreeze, id, a + p_{Au}, id_{Au})$, and $(unfreeze, id, b + p_S, id_S)$, send $(check_pass, id)$.
 - If any of the criteria fails, call \mathcal{L} with $(unfreeze, id, b + \frac{a}{2}, id_S)$ and $(unfreeze, id, p_S + p_{Au} + \frac{a}{2}, id_O)$. Send $(penalized, id, id_{Au})$.

Fig. 6. Ideal Functionality $\mathcal{G}_{JC}^{\mathcal{L}}$ for the judge contract

$REAL_{\Pi_C, \mathcal{A}, \mathcal{Z}}^{\mathcal{F}_{ecdsa}, \mathcal{G}_{JC}^{\mathcal{L}}, \mathcal{H}}(\lambda, x)$ be the ensemble of the outputs of the environment \mathcal{Z} when interacting with the attacker \mathcal{A} and users running protocol Π_C on input 1^λ , where λ is the security parameter, and auxiliary input $x \in \{0, 1\}^*$, in the hybrid world having access to the ideal functionalities. The parties interact with each other via $\mathcal{F}_{Audit}^{\mathcal{L}}$ in the ideal world in the presence of the ideal attacker Sim . $IDEAL_{Sim, \mathcal{Z}}^{\mathcal{F}_{Audit}^{\mathcal{L}}, \mathcal{H}, \mathcal{L}}(\lambda, x)$ be the ensemble of the outputs of the environment \mathcal{Z} when interacting with the ideal world.

THEOREM 7.1. Global UC Security. *Given that λ is the security parameter and ECDSA signatures are strongly existentially unforgeable, a protocol Π_C is said to GUC-realizes an ideal functionality $\mathcal{F}_{Audit}^{\mathcal{L}}$ in the $(\mathcal{F}_{ecdsa}, \mathcal{G}_{JC}^{\mathcal{L}}, \mathcal{H})$ -hybrid world*

(Server-Auditor: Closing Channel)

- Receive $(complaint, id, Q, sig_Q, (\mu, \sigma), id_S)$ from Au
 - Send (get_latest_state, id) to \mathcal{L} , gets the value returned by \mathcal{L} , and stores the value in variable $seed$.
 - Check $SigVerify(Q, sig_Q, pk_a) \stackrel{?}{=} 1$. Generate $|Q|$ many queries from $seed$, and obtain Q' . If $Q \neq Q'$, then go to step *Penalize1*.
 - Else, parse Q to get (i, v_i) , where i is the index of the file chunk. If $\mu \neq \phi$ and $\sigma \neq \phi$, check $e(\sigma, g) \stackrel{?}{=} e(\prod_{(i, v_i) \in Q} H(i)^{v_i} u^\mu, v)$. If this does not hold or if any of the response is empty, go to *Wait for Response*. Else go to step *Penalize1*.
 - *Wait for Response*: If S sends $(\mu', \sigma') : e(\sigma', g) \stackrel{?}{=} e(\prod_{(i, v_i) \in Q} H(i)^{v_i} u^{\mu'}, v)$, then go to *Penalize1*. If S doesn't respond or the equation fails, go to step *Penalize2*.
 - *Penalize1*: Call \mathcal{L} with $(unfreeze, id, \frac{a}{2} + b, id_S)$, and $(unfreeze, id, \frac{a}{2} + p_S + p_{Au}, id_O)$. Send $(penalized, id, id_{Au})$.
 - *Penalize2*: Call \mathcal{L} with $(unfreeze, id, \frac{b}{2} + a, id_{Au})$ and $(unfreeze, id, \frac{b}{2} + p_S + p_{Au}, id_O)$. Send $(penalized, id, id_S)$.
- Receive $(complaint, id, Q, sig_Q, id_{Au})$ from S
 - Send (get_latest_state, id) to \mathcal{L} , gets the value returned by \mathcal{L} , and stores the value in variable $seed$.
 - Check $SigVerify(Q, sig_Q, pk_a) \stackrel{?}{=} 1$. Generate $|Q|$ many queries from $seed$, and obtain Q' . If $Q \neq Q'$ or signature check fails then call \mathcal{L} with $(unfreeze, id, b + \frac{a}{2}, id_S)$ and $(unfreeze, id, p_S + p_{Au} + \frac{a}{2}, id_O)$. Send $(penalized, id, id_{Au})$.
 - If comparison check holds true and signature is valid, call \mathcal{L} with $(unfreeze, id, \frac{b}{2} + a, id_{Au})$ and $(unfreeze, id, p_S + p_{Au} + \frac{b}{2}, id_O)$. Send $(penalized, id, id_S)$.

Fig. 6. Ideal Functionality $\mathcal{G}_{JC}^{\mathcal{L}}$ for the judge contract (Contd.)

if for all computationally bounded adversary \mathcal{A} attacking Π_C , there exist a probabilistic polynomial time (PPT) simulator Sim such that for all PPT environment \mathcal{Z} and for all $x \in \{0, 1\}^*$, $IDEAL_{Sim, \mathcal{Z}}^{\mathcal{F}_{Audit}^{\mathcal{L}}, \mathcal{H}, \mathcal{L}}(\lambda, x)$, and $REAL_{\Pi_C, \mathcal{A}, \mathcal{Z}}^{\mathcal{F}_{ecdsa}, \mathcal{G}_{JC}^{\mathcal{L}}, \mathcal{H}}(\lambda, x)$ are computationally indistinguishable.

Proof: To prove that our proposed protocol is *GUC-secure*, we need to show that any PPT environment \mathcal{Z} can distinguish the execution of the protocol in hybrid world from the ideal world with negligible probability. We construct a simulator Sim that outputs all messages such that it looks like the hybrid world execution to \mathcal{Z} . The first version of *Cumulus*, defined in Fig.7, is more efficient but has a weaker privacy guarantee, the second version defined in Fig.9 is more privacy-preserving but lacks efficiency. Sim orchestrates the response depending on which version of the protocol it is trying to simulate in the ideal world.

The transcript of the protocol generated in the hybrid world must not be distinguishable even in presence of corrupted parties. We consider total of eight cases, the protocol execution with all honest parties, execution with a malicious owner O^* , execution with a dishonest server S^* , execution with dishonest auditor Au , three cases for execution with either of two parties in set $\{O, S, Au\}$ being dishonest, and the case where all parties are corrupt.

We consider that Sim internally simulates the execution of $\mathcal{G}_{JC}^{\mathcal{L}}$, suppressing any calls made to ledger \mathcal{L} and has access to the global random oracle \mathcal{H} and \mathcal{F}_{ecdsa} for signing messages on behalf of each party. We assume that u, g are public parameters.

- *Simulation without corruptions*: The simulator Sim , defined in Fig.10, is just required to match the transcript of all messages of the execution of *Cumulus* in the hybrid world. Since all three parties are honest, none of the messages exchanged between these parties is leaked to \mathcal{Z} . Since Sim has no access to the file F , it generates a random bit

The protocol consists of description of the behavior of honest owner O , server S and auditor Au . It is assumed that the parties has access to global random oracle \mathcal{H} and global ledger \mathcal{L} .

Init Variables: u, g are generators of group G of order p .

(Initialize)

- Upon receiving $(store, id, F, p_S, p_{Au}, n, query_count, id_{Au}, id_S)$, O selects the group G based on λ , generators $u, g \in G$. O, S and Au calls Keygen function \mathcal{F}_{ecdsa} and gets their secret key and public key pairs. The public key of O, S and Au are pk_o, pk_s , and pk_a .
- O sends $(init, id, pk_o, pk_a, pk_s, u, v, g, \text{contract terms}, query_count, id_S, id_{Au})$ to $\mathcal{G}_{JC}^{\mathcal{L}}$. If it returns $(initialized, registered id_O, registered id_S, registered id_{Au})$, then continue, else abort.

(File transfer from Owner to Server)

- O divides F into n blocks, m_1, m_2, \dots, m_n , where each $m_i \in \mathbb{Z}_p, i \in [1, n]$.
- It generates authentication tags $\sigma_i = [\mathcal{H}(i)u^{m_i}]^x, 1 \leq i \leq n$ and calculate $h_i = \mathcal{H}(m_i || \sigma_i), 1 \leq i \leq n$. Send (m_i, σ_i) to S .
- S checks $e(g, \sigma_i) \stackrel{?}{=} e(v, H(i)u^{m_i}), \forall 1 \leq i \leq n$. If the check holds for all the file chunks, it generates $h'_i = \mathcal{H}(m_i || \sigma_i)$ and signs by calling $t = \text{Sign}(O, [h'_1, h'_2, \dots, h'_n])$ of \mathcal{F}_{ecdsa} , sends $([h'_1, h'_2, \dots, h'_n], t)$ to O .
- O calls $\text{SigVerify}([h'_1, h'_2, \dots, h'_n], t, pk_s)$ of \mathcal{F}_{ecdsa} , checks if value returned is 1, and $h'_i \stackrel{?}{=} h_i, i \in [1, n]$. If any check fails, abort.
- O signs by calling $\sigma_{file} = \text{Sign}(O, ([h'_1, h'_2, \dots, h'_n], t))$ of \mathcal{F}_{ecdsa} , and sends $(verify, id, [h'_1, h'_2, \dots, h'_n], t, \sigma_{file})$ to $\mathcal{G}_{JC}^{\mathcal{L}}$. If it responds with $(verified, id)$, then continue, else abort.
- O sends (g, u, v, pk_o) to Au and call \mathcal{L} with $(freeze, id, p_S + p_{Au}, id_O)$. Au sends an acknowledgement.

(Server-Auditor: Opening Channel)

- Au sends $(open_channel, id, a, id_S)$ to S and waits for 1 round to receive acknowledgement from S .
- If S sends $(open_channel, id, b, id_{Au})$ to Au , the latter sends $(open_channel, id, a, id_{Au}, b, id_S)$ to $\mathcal{G}_{JC}^{\mathcal{L}}$. If S doesn't respond in this round, O calls \mathcal{L} with $(unfreeze, id, p_S + p_{Au}, id_O)$ and abort.
- If $\mathcal{G}_{JC}^{\mathcal{L}}$ responds $(opened_channel, id)$, then continue, else O calls \mathcal{L} with $(unfreeze, id, p_S + p_{Au}, id_O)$ and abort.
- S sends (get_latest_state, id) to \mathcal{L} , gets the value returned by \mathcal{L} , and stores the value in variable $seed$.
- Au and S , each initializes $Q_{all} = \mu_{all} = \sigma_{all} = \phi$ and $firstFlag = 1$.

(Server-Auditor: Query and Response)

- **Query Phase:** Au sends $(query, id, Q, sig_Q, id_S)$ to S .
- S adds $Q_{all} = Q_{all} \cup Q$, check if Q can be generated from $seed$. If Q cannot be generated from $seed$ or if $\text{SigVerify}(Q, sig_Q, pk_a)$ of \mathcal{F}_{ecdsa} return 0, it sends $(complaint, id, Q, sig_Q, id_{Au})$ to $\mathcal{G}_{JC}^{\mathcal{L}}$ and terminates the protocol.
- If the above criteria holds, S parses Q and retrieves $\{(i, v_i)\}$, generates $\sigma = \prod_{(i, v_i) \in Q} \sigma_i^{v_i}, \mu = \sum_{(i, v_i) \in Q} v_i m_i$, creates $R = (\sigma, \mu)$, sends $(response, id, R, id_S)$ to Au . It adds $\mu_{all} = \mu_{all} + \mu$ and $\sigma_{all} = \sigma_{all} \times \sigma$.
- Au parses R , gets (σ, μ) , verifies whether $e(\sigma, g) \stackrel{?}{=} e(\prod_{(i, v_i) \in Q} H(i)^{v_i} u^\mu, v)$. If the check fails, it sends $(complaint, id, Q, sig_Q, (\mu, \sigma), id_S)$ to $\mathcal{G}_{JC}^{\mathcal{L}}$. Else it may either go back to **Query Phase** and repeat the steps, or it may send $(close, id, Q_{all}, sig_{Q_{all}}, (\mu_{all}, \sigma_{all}))$ to $\mathcal{G}_{JC}^{\mathcal{L}}$.

(Server-Auditor: Closing Channel)

- If the output is $(penalized, id, id_S)$ or $(penalized, id, id_{Au})$, it is sent to id_O, id_S and id_{Au} , and the protocol terminates.
- If Au receives $(check_pass, id)$, then it sends it to id_O . The latter now sends $(fetch_file, id)$ to id_S . The latter gets the file F and terminates the protocol.

Fig. 7. The formal description of the protocol

string having length same as the size of the file, and performs all the operations S on the dummy file. \mathcal{Z} who has no access to the file, cannot distinguish between the output of Sim and output by an auditor upon channel closure.

(Server-Auditor: Closing Channel)

- Receive $(close, id, Q, sig_Q, (R, \mu, \sigma))$ from Au
 - Parse Q to get (i, v_i) , where i is the index of the chunk. Generate $W_i = (file_id||i) \forall i \in Q$, verify whether $R.e((\sigma)^\gamma, g) \stackrel{?}{=} e((\prod_{(i, v_i) \in Q} H(W_i)^{v_i})^\gamma . u^\mu, v)$. If this holds true and $\frac{|Q|}{query_count} \geq 1$, call \mathcal{L} with $(unfreeze, id, a + p_{Au}, id_{Au})$, and $(unfreeze, id, b + p_S, id_S)$, send $(check_pass, id)$.
 - If any of the criteria fails, call \mathcal{L} with $(unfreeze, id, b + \frac{a}{2}, id_S)$ and $(unfreeze, id, p_S + p_{Au} + \frac{a}{2}, id_O)$. Send $(penalized, id, id_{Au})$.
- Receive $(complaint, id, Q, sig_Q, (R, \mu, \sigma), id_S)$ from Au
 - Send (get_latest_state, id) to \mathcal{L} , gets the value returned by \mathcal{L} , and stores the value in variable $seed$.
 - Check $SigVerify(Q, sig_Q, pk_a) \stackrel{?}{=} 1$. Generate $|Q|$ many queries from $seed$, and obtain Q' . If $Q' = Q$, then go to step *Penalize1*.
 - Else, parse Q to get (i, v_i) , where i is the index of the file chunk. Generate $W_i = (file_id||i) \forall i \in Q$, verify whether $R.e((\sigma)^\gamma, g) \stackrel{?}{=} e((\prod_{(i, v_i) \in Q} H(W_i)^{v_i})^\gamma . u^\mu, v)$. If this does not hold or if any of the response is empty, go to *Wait for Response*. Else go to step *Penalize1*.
 - *Wait for Response*: If S sends (R, μ', σ') : generate $W_i = (file_id||i) \forall i \in Q$, verify whether $R.e((\sigma)^\gamma, g) \stackrel{?}{=} e((\prod_{(i, v_i) \in Q} H(W_i)^{v_i})^\gamma . u^\mu, v)$. If this holds true, then go to *Penalize1*. If S doesn't respond or the above equation fails, go to step *Penalize2*.
 - *Penalize1*: Call \mathcal{L} with $(unfreeze, id, \frac{a}{2} + b, id_S)$, and $(unfreeze, id, \frac{a}{2} + p_S + p_{Au}, id_O)$. Send $(penalized, id, id_{Au})$.
 - *Penalize2*: Call \mathcal{L} with $(unfreeze, id, \frac{b}{2} + a, id_{Au})$ and $(unfreeze, id, \frac{b}{2} + p_S + p_{Au}, id_O)$. Send $(penalized, id, id_S)$.

Fig. 8. Ideal Functionality $\mathcal{G}_{JC}^{\mathcal{L}}$ for the judge contract (privacy preserving)**(Server-Auditor: Query and Response)**

- *Query Phase*: Au sends $(query, id, Q, sig_Q, id_S)$ to S .
- S adds $Q_{all} = Q_{all} \cup Q$, check if Q can be generated from $seed$. If Q cannot be generated from $seed$ or if $SigVerify(Q, sig_Q, pk_a) = 0$, it sends $(complaint, id, Q, sig_Q, id_{Au})$ to $\mathcal{G}_{JC}^{\mathcal{L}}$ and terminates the protocol.
- If the above criteria satisfies, S parses Q and retrieves $\{(i, v_i)\}$, generates $\sigma = \prod_{(i, v_i) \in Q} \sigma_i^{v_i}$, $R = e(u, v)^r$, $\gamma = h(R)$
 - if** $firstFlag == 1$ **then**
 - $\mu = r + \gamma \times \sum_{(i, v_i) \in Q} v_i m_i$
 - $firstFlag = 0$
 - else**
 - $\mu = \gamma \times \sum_{(i, v_i) \in Q} v_i m_i$
 - end**
- creates $\hat{R} = (R, \sigma, \mu)$, sends $(response, id, \hat{R}, id_S)$ to Au . It adds $\mu_{all} = \mu_{all} + \mu$ and $\sigma_{all} = \sigma_{all} \times \sigma$.
- Au parses \hat{R} , gets (R, σ, μ) , generate $W_i = (file_id||i) \forall i \in Q$, verify whether $R.e((\sigma)^\gamma, g) \stackrel{?}{=} e((\prod_{(i, v_i) \in Q} H(W_i)^{v_i})^\gamma . u^\mu, v)$. If the check fails, it sends $(complaint, id, Q, sig_Q, (R, \mu, \sigma), id_S)$ to $\mathcal{G}_{JC}^{\mathcal{L}}$. Else it may either go back to *Query Phase* and repeat the steps, or it may send $(close, id, Q_{all}, sig_{Q_{all}}, (R, \mu_{all}, \sigma_{all}))$ to $\mathcal{G}_{JC}^{\mathcal{L}}$.

Fig. 9. The formal description of the protocol (Privacy-Preserving version). We just mention the difference of this protocol from the version mentioned in Fig. 7

- *Simulation when O is dishonest*: The simulator is defined in Fig.11. The dishonest owner will be able to generate $h'_i, 1 \leq i \leq n$ such that it matches with the hash of the chunks had it possessed the correct file with probability $\frac{1}{p^n}$.

This is the only bad case where *Sim* aborts but the protocol execution in hybrid world will continue. But since the probability is negligible, the two executions can be distinguished with negligible probability.

- *Simulation when \mathcal{S} is dishonest:* We define the simulator for a dishonest server in Fig. 12. In the first step, even if the dishonest sever manages to generate tag σ_i without actually having the message m_i , it will never pass the check $h_i = \mathcal{H}(m^* || \sigma_i)$ if $m^* \neq m_i$. Since we consider ECDSA signature to be existentially unforgeable, the malicious sender cannot forge a signature without possessing the correct secret key.

In the auditing phase, given a query Q , the sender may try to guess the response (μ', σ') . Probability of guessing the tuple correctly is $\frac{1}{p^2}$, where $Pr[\mu = \mu'] = \frac{1}{p}$ and $Pr[\sigma = \sigma'] = \frac{1}{p}$. This is a bad event and *Sim* aborts if this event occurs. Since $\frac{1}{p^2}$ is a negligible quantity, probability of *Sim* aborting is negligible. Since we consider the signature scheme is secure, the probability of this bad event occurring is negligible.

- *Simulation when Au is dishonest:* We define the simulator for a dishonest server in Fig. 13. The bad case can arise in two situation: (i) *Au* raises a false complaint that \mathcal{S} has send a wrong query. However, in that case, *Au* needs to forge \mathcal{S}' 's signature as well and this is possible with negligible probability. (ii) The next bad case arises when *Au* submits a channel closure request but without the correct response. This will be detected by the ideal judge contract and probability of the bad event is 0. Also, it is possible that the malicious auditor has not interacted with server and tries to generate response for a given query set. Since we show that probability of guessing a such a tuple is $\frac{1}{p^2}$ in the previous instance where \mathcal{S} was dishonest, so the bad event is possible with negligible probability.
- *Simulation when O, \mathcal{S} are dishonest:* We define the simulator for a dishonest server in Fig. 14. The only point where both the parties can collude and try to steal coins from an honest *Au* is when they falsely raise a complaint about a wrong query. However, ECDSA signature is existentially unforgeable, the attack is possible only with negligible probability.
- *Simulation when O, Au are dishonest:* In no way can the two dishonest parties cheat an honest sender who possesses the correct response to each query. We define the simulator in Fig. 15.
- *Simulation when \mathcal{S}, Au are dishonest:* We define the simulator for a dishonest server in Fig. 16. It is possible that the malicious auditor-server pair tries to generate response for a given query set. Probability of guessing the tuple correctly is $\frac{1}{p^2}$, where $Pr[\mu = \mu'] = \frac{1}{p}$ and $Pr[\sigma = \sigma'] = \frac{1}{p}$. This is a bad event and *Sim* aborts if this event occurs. Since $\frac{1}{p^2}$ is a negligible quantity, probability of *Sim* aborting is negligible.
- *Simulation when all parties are dishonest:* With all three parties behaving dishonestly, the action set is exponential in size and cannot be captured here. This case does not guarantee any fairness and might not even terminate. We therefore skip discussions for this bad case.

8 IMPLEMENTATION AND PERFORMANCE ANALYSIS

In this section, we analyze a realistic cloud setting of blockchain enabled data audit scheme that we have implemented.

8.1 Implementation Setup

We implement AuB and evaluate a prototype using Ethereum as a blockchain platform. Our entire code is approximately 1500 lines, consisting of Ethereum smart contracts written in Solidity language, Go-Ethereum modifications written in Golang and other experimentation glue code written in Python and Bash.²

²<https://bit.ly/2L6W55n> and <https://bit.ly/2J0z1Ct>

- *Sim* receives $(|F|, n, p_S, p_{Au}, seed, id_S, id_O, id_{Au})$ from $\mathcal{F}_{Audit}^{\mathcal{L}}$.
 - It samples $(sk_o, pk_o), (sk_s, pk_s)$ and (sk_a, pk_a) , and simulates the execution of protocol by sending $(init, id, pk_o, pk_a, pk_s, u, v, g, \text{contract terms}, query_count, id_S, id_{Au})$ to $\mathcal{G}_{JC}^{\mathcal{L}}$.
 - It generates a file $F' = 1^{|F|}$ and generates m'_1, m'_2, \dots, m'_n by breaking F' into n chunks of equal size.
 - *Sim* samples a secret key x' and public key $v' = g^{x'}$ and creates $\sigma_i = [\mathcal{H}(i)u^{m'_i}]^{x'}, h_i = \mathcal{H}(m'_i || \sigma_i), i \in [1, n]$.
 - *Sim* simulates these steps on behalf of \mathcal{O} and \mathcal{S} . It signs $t = \text{Sign}([h_1, h_2, \dots, h_n], sk_s)$, and again countersigns $\sigma_{file} = \text{Sign}([h_1, h_2, \dots, h_n], t, sk_o)$, and simulates the execution of protocol by sending $(verify, id, [h_1, h_2, \dots, h_n], t, \sigma_{file})$ to $\mathcal{G}_{JC}^{\mathcal{L}}$.
- *Sim* receives $(open_channel, id, b, id_{Au})$.
 - It simulates the execution of protocol by sending $(open_channel, id, a, id_{Au}, b, id_S)$ to $\mathcal{G}_{JC}^{\mathcal{L}}$.
- *Sim* receives $(query, id, Q)$:
 - If it observes \mathcal{L} has received $(unfreeze, id, b + \frac{a}{2}, id_S)$ and $(unfreeze, id, p_S + p_{Au} + \frac{a}{2}, id_O)$, then it sends $(complaint, id, Q, sign_{sk_a}(Q), id_{Au})$ to $\mathcal{G}_{JC}^{\mathcal{L}}$.
 - If it observes \mathcal{L} has received $(unfreeze, id, a + \frac{b}{2}, id_{Au})$ and $(unfreeze, id, p_S + p_{Au} + \frac{b}{2}, id_O)$, then it sets $\mu = \sum_{(i, v_i) \in Q} v_i m'_i$, and $\sigma = \phi$, and sends $(complaint, id, Q, sign_{sk_a}(Q), (\mu, \sigma), id_S)$ to $\mathcal{G}_{JC}^{\mathcal{L}}$.
- *Sim* receives $(close, id, Q, \mu)$:
 - If it observes that $\frac{|Q|}{query_count} \geq 1$, and \mathcal{L} has received $(unfreeze, id, b + \frac{a}{2}, id_S)$ and $(unfreeze, id, p_S + p_{Au} + \frac{a}{2}, id_O)$, then it sets $\mu = \sum_{(i, v_i) \in Q} v_i m'_i$, and $\sigma = \phi$ and goes directly to step *Call*.
 - Else, it parses Q and gets $\{(i, v_i)\}$, generates $\mu = \sum_{(i, v_i) \in Q} v_i m'_i$ and $\sigma = \prod_{(i, v_i) \in Q} \sigma_i^{v_i}$.
 - *Call*: *Sim* signs the query Q using sk_a , simulates the execution of protocol by sending $(close, id, Q, sign_{sk_a}(Q), (\mu, \sigma))$ to $\mathcal{G}_{JC}^{\mathcal{L}}$.

Fig. 10. Simulator Sim^{honest} for without corruption

- Upon receiving $(init, id, p_S, p_{Au}, pk_o, pk_a, pk_s, u, v, g, \text{contract terms}, query_count, id_S, id_{Au})$ from \mathcal{O}^* , *Sim* simulates execution by sending it to $\mathcal{G}_{JC}^{\mathcal{L}}$.
- \mathcal{O}^* sends $\{(m_i, \sigma_i) : 1 \leq i \leq n\}$, *Sim* checks if $e(g, \sigma_i) = e(v, H(i)u^{m_i})$. If it holds true for all file chunks, it creates file $F^* = \{m_i : 1 \leq i \leq n\}$
- \mathcal{O}^* sends $(verify, id, [h'_1, h'_2, \dots, h'_n], t, \sigma_{file})$ to *Sim*. The latter checks if $h'_i = \mathcal{H}(m_i || \sigma_i), 1 \leq i \leq n$. If there is a mismatch abort.
- *Sim* simulates execution by sending the message to $\mathcal{G}_{JC}^{\mathcal{L}}$. If $\text{SigVerify}(m, t, pk_s) = 1$ and $\text{SigVerify}((m, t), s, pk_o) = 1$, send $(store, id, F^*, p_S, p_{Au}, query_count, n, id_{Au}, id_S)$ to $\mathcal{F}_{Audit}^{\mathcal{L}}$.

Fig. 11. Simulator $Sim^{O, corrupted}$

We needed to perform Bilinear Pairing checks for symmetric pairing inside Ethereum smart contract, to verify audit responses. In this regard, the original Ethereum platform does not support pairing based operations on symmetric groups natively. Post Byzantium, it had introduced pairing operations on a fixed asymmetric group, in order to support Zero-Knowledge proof verification. It was impractical to port some pairing-based cryptography library into Solidity and hence we modified the Ethereum code to include a new pre-compiled contract which supported pairing-based operations. To be specific, the new pre-compiled contract verified the audit equation given in Eq.1.

- $\mathcal{F}_{\text{Audit}}^{\mathcal{L}}$ sends file F to Sim . The latter parses F to m_1, m_2, \dots, m_n .
- S^* sends $\{\sigma_i : 1 \leq i \leq n\}, ([h'_1, h'_2, \dots, h'_n], t)$ to Sim . The latter checks if $e(g, \sigma_i) \stackrel{?}{=} e(v, H(i)u^{m_i})$, and $h_i = \mathcal{H}(m_i || \sigma_i), 1 \leq i \leq n$, and $SigVerify([h'_1, h'_2, \dots, h'_n], t, pk_s) \stackrel{?}{=} 1$, if any of the check fails, send $(abort, id)$ to $\mathcal{F}_{\text{Audit}}^{\mathcal{L}}$.
- Upon receiving $(open_channel, id, a, id_S)$, Sim forwards the message to S^* . If the latter responds with $(open_channel, id, b, id_{Au})$, it initiates opening of channel. If no message is received, it sends $(abort, id)$ to $\mathcal{F}_{\text{Audit}}^{\mathcal{L}}$.
- S^* sends (σ', μ') to Sim , the latter checks that for corresponding Q , $\sigma' = \prod_{(i, v_i) \in Q} \sigma_i^{v_i}$, $\mu' = \sum_{(i, v_i) \in Q} v_i m_i$.
- If S^* sends $(complaint, id, Q, sig_Q, id_{Au})$ to Sim , the latter checks if Q is valid query generated from $seed$ and if $SigVerify(Q, sig_Q, pk_a) = 1$. If any of the check fails, it sends $(abort, id)$ to $\mathcal{F}_{\text{Audit}}^{\mathcal{L}}$.

Fig. 12. Simulator $Sim^{S, corrupted}$

- If Au^* sends $(complaint, id, Q, sig_Q, (\mu', \sigma'), id_{Au})$ to Sim , the latter checks if Q is valid query generated from $seed$ and if $SigVerify(Q, sig_Q, pk_a) = 1$. If any of the check fails, it sends $(abort, id)$ to $\mathcal{F}_{\text{Audit}}^{\mathcal{L}}$. If the check is valid, then Sim checks if \mathcal{L} has taken any action or remains inactive. If the latter happens then Sim sends $(abort, id)$. If funds are unfrozen penalizing server S , then it does nothing.
- If Au^* sends $(close, id, Q, sig_Q, (\mu', \sigma'), id_{Au})$ to Sim , parse Q to get (i, v_i) , where i is the index of the chunk. Check $e(\sigma, g) \stackrel{?}{=} e(\prod_{(i, v_i) \in Q} H(i)^{v_i} u^{\mu}, v)$. If this is not true send $(abort, id)$ to $\mathcal{F}_{\text{Audit}}^{\mathcal{L}}$.

Fig. 13. Simulator $Sim^{Au, corrupted}$

- O^* and S^* collude and try to cheat Au . It is possible either by supplying a wrong $seed$ or raising a dispute on the query set Q .
- Since $seed$ is present in the ideal judge contract, this attack can be ruled out.
 - The latter case is possible, if they can forge Au 's signature. This is possible with negligible probability.

Fig. 14. Simulator $Sim^{(O, S), corrupted}$

- O^* and Au^* collude and try to cheat S .
- Same as the case when Au^* was corrupted. If Au^* tries to suppress or send a wrong response, then judge contract will wait for the correct response from S . If an honest S responds, then it will be paid accordingly.

Fig. 15. Simulator $Sim^{(O, Au), corrupted}$

- If Au^* sends $(close, id, Q, sig_Q, (\mu', \sigma'), id_{Au})$ to Sim , parse Q to get (i, v_i) , where i is the index of the chunk. Check $e(\sigma, g) \stackrel{?}{=} e(\prod_{(i, v_i) \in Q} H(i)^{v_i} u^{\mu}, v)$. If this is not true send $(abort, id)$ to $\mathcal{F}_{\text{Audit}}^{\mathcal{L}}$.

Fig. 16. Simulator $Sim^{(Au, S), corrupted}$

We have used the most popular Ethereum implementation, Go Ethereum also known as geth, which is written in Golang. For the mathematical operations, we needed a library which supports arithmetic in \mathbb{Z}_p , elliptic curve groups with operations and bilinear pairing computation. Hence, we used the Golang wrapper [50] of the popular PBC Library [34].

We included the PBC library inside the geth code and introduced the pre-compiled contract. We used Type A pairings which are very fast, but elements take a lot of space to represent. Because of the modified Ethereum code, we used a private network for our experimentation.

For the Shacham-Waters audit code implementation, we used their extended definition with file sectors. As discussed in algorithm??, we split file F into n blocks $m_1, m_2, \dots, m_n \in \mathbb{Z}_p$. For each block m_i , tag $\sigma_i \in G$ is calculated, where G is group whose support is \mathbb{Z}_p . Calculating tags for the main file F causes a significant overhead if we generate tags as above. So, we used the concept of sectors as introduced by Shacham-Waters. Let s be a parameter and each block consist of s sectors, where $|s| \in \mathbb{Z}_p$. As there is only one tag for one block (contains s sectors), tag generation overhead is reduced by $\approx 1/s$ if n is large enough.

8.2 Evaluation

We deployed our implementation on a private Ethereum network consisting of two nodes. We used a single machine with 4-core Intel Xeon E3 – 1200 and 8GB of RAM running Linux (Manjaro 64-Bit XFCE). The storage server, owner and auditor codes were running alongside the Ethereum nodes. The elliptic curve utilized in our experiment is a supersingular curve, with a base field size 512 bits and the embedding degree 2. We use different file sizes, starting from 1KB to 100MB.

Sector size $|s|$, is 19 Bytes in our construction which is dependent upon parameters we used for the construction of elliptic curves. We use 1000 sectors per block in our construction which we noticed is optimized value for current setup.

The main objective of our prototype implementation was to observe the overhead in introducing the distributed computing platform. In particular, we wanted to calculate latency from each of the parties perspective, i.e., how much additional time does the owner spend in uploading and downloading files, the auditor spends in challenge-response and the server spends on file and audit management. To observe this, we perform same experiment with and without the blockchain related calls and look into the latencies in each case.

Firstly, we look into the latency faced by the owner during upload of file. In Fig. 17, we note that although for small files the blockchain latency remains considerable, with increasing file sizes, the commit time becomes negligible compared to the file upload time. As practical storage servers store files in order of Gigabytes, the overhead for the owner is negligible. A thing to note is that the same applies for the server as well because the owner latency includes the server signing during file uploads.

The protocol does not demand any additional ledger interactions during proof generation and hence we observed no significant overhead for the servers, as shown in Fig. 18.

An auditor performs audit over a long period of time. For example, an auditor may send one query to the server every hour. It may have to send the aggregated response to the smart contract only at the end of the day. Hence, in Fig. 19 although we observe a dominant overhead of blockchain interaction compared to response verification over 10 queries, we note that the time axis is not an honest representation of practice where the audit will be performed over a considerably long period of time as compared to the commit time.

Overall, in Fig. 20, we see that for the owner and server, our protocol adds minimal overhead. For the auditor, if it is compared against the span of the entire audit process, the additional latency remains negligible, given that the auditor performs the audit over a sufficiently long duration of time.

Table 1 shows the metrics calculated with 5 different query sizes keeping the file size constant at 1 MB. The gas cost in USD is calculated at average gas price of 3 gwei and an exchange rate of 1 ETH = 153 USD. The empty block size in our private network is 540 bytes. This shows that if a single audit takes 1400 bytes, 1 MB data on the blockchain would

accommodate roughly 750 audits. We note here that the block size increase is not linear to the number of queries as only the aggregated response is submitted to the blockchain. Each channel session can communicate a large number of audits hence in practice, thousands of such audits can be done with an overhead of few kilobytes.

In comparison to previous work like [11], not only is our proof generation time lower, our proof size is also smaller as it is aggregated over hundreds of proofs over time. This is because of the off-chain nature of our solution.

#Queries	Gas Cost	Gas Cost (\$)	Block Overhead	Auditing Time	BC Time
1	110087	0.0512	1394 B	72.808527ms	6.220183447s
3	115220	0.05358	1458 B	65.074692ms	6.215553521s
5	120486	0.05603	1554 B	69.638309ms	7.229788269s
7	125619	0.05842	1618 B	67.183777ms	5.818474706s
10	133451	0.06206	1746 B	69.449573ms	6.219303512s

Table 1. Cost of audit for file size of 1MB.

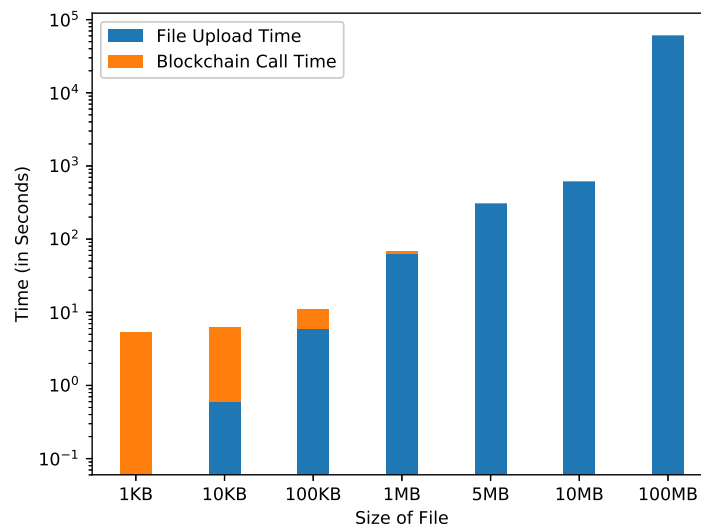
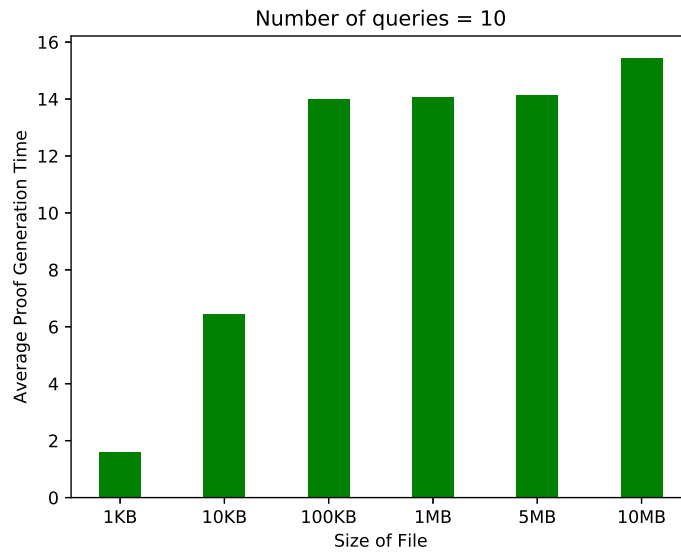
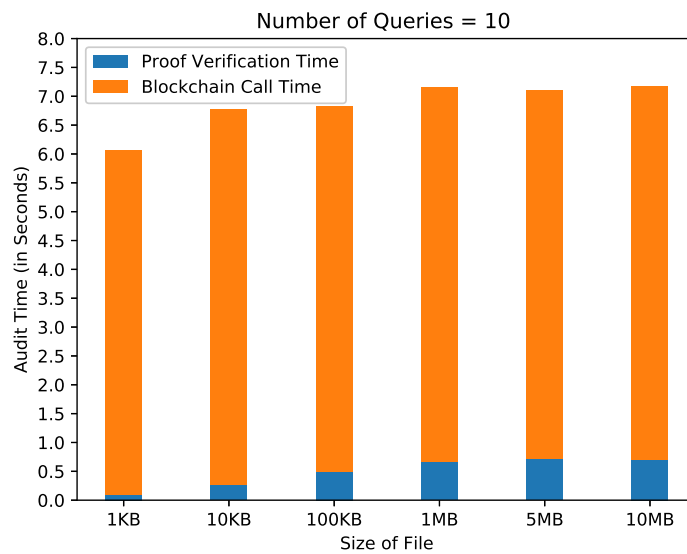

Fig. 17. File upload time for different $|F|$

Fig. 18. Proof generation time for different $|F|$ Fig. 19. Proof verification time for different $|F|$

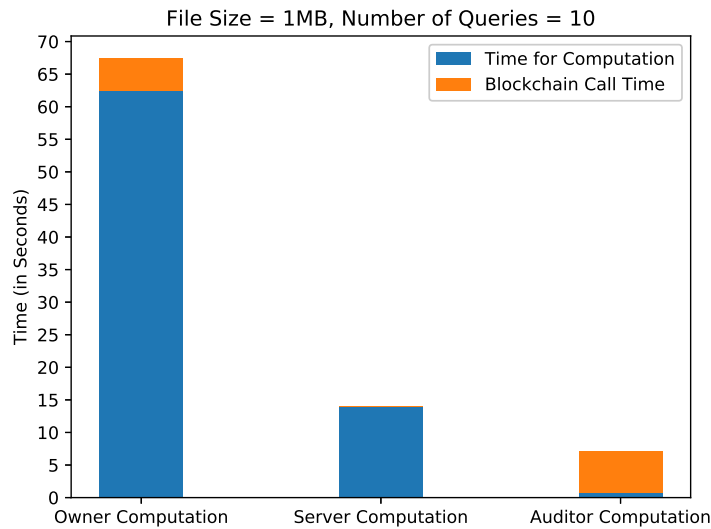

Fig. 20. Computational time for all parties

9 DISCUSSION

We wanted to use blockchain as the source of randomness for generating query set. As given in [9], for small amounts of randomness, if the stakes are low enough, the blockchain can be used as a source of randomness. We believe that for our audit purposes, the incentive for parties to collude with miners is low enough. Any other public source of randomness could have been used. External sources of randomness have a separate trust assumption and then we would have needed to consider all the collusion cases with the random source. Our only requirement is that the peers of the blockchain network need to have access to the same source and must access the same random value in order to receive consensus. We referred a single block hash for each contract instance, hence the query set for a channel can be derived at once, after the opening of the channel.

File upload time is very much dependent on number of sectors per block as well as size of sector. Sector size $|s|$, is determined by the parameters and choice of algorithm used for elliptic curve generation.

We have implemented our pairing check as a new pre-compiled contract. Hence, the gas required by the contract has been estimated by us. In a practical situation, either such a symmetric bilinear pairing support comes baked into Ethereum, in which case the community decides upon the gas cost, or, a private network is setup among interested parties where they themselves decide upon the gas requirement. The asymmetric pairing check pre-compiled contract takes $80000 * k + 100000$ as the gas (k is the number of points on the curve). Upon using similar calculation, our audit check transaction took 888387 gas. We have not used this in our performance metric as we think this will depend upon the platform.

The channel closing codes written in our contract is far from ideal. It does not take into account all possible corner cases, but arbitrary complicated code could have been implemented based on the requirements. We have just showed a sample code for the prototype. Also, we note here that in a classical audit scenario, both auditor and server needs to be

online during audit phase. For our proposed state channel to work, this is the exact requirement and hence it imposes no additional restrictions.

10 CONCLUSION

In this paper we introduced a blockchain based privacy preserving audit protocol which is resilient even when any two out of the data owner, storage server and auditor is malicious. We used state channels to minimize blockchain commits thereby improving efficiency. Through smart contracts, we enforced the incentive mechanism in the system. We also build a prototype on modified Ethereum and show that the protocol incurs minimal overhead compared to existing PoR scheme.

In terms of future work, we wish to explore possibilities to enhance efficiency of the protocol by using other elliptic curves. We also aim to adopt an audit protocol without bilinear pairing operations so that it can be readily deployed on blockchain platforms like Ethereum, without modifying the codebase. This would enable us to test on networks beyond a private network, like testnets and main network.

ACKNOWLEDGMENT

This work is partially supported by Cisco University Research Program Fund, CyberGrants ID: #698039 and Silicon Valley Community Foundation. The authors would like to thank Chris Shenefiel and Samir Saklikar for their comments and suggestions. The work is also partially supported by the European Research Council (ERC) under the European Union's Horizon 2020 research (grant agreement 771527- BROWSEC), by the Austrian Science Fund (FWF) through the projects PROFET (grant agreement P31621), and the project W1255- N23, by the Austrian Research Promotion Agency (FFG) through the COMET K1 SBA and COMET K1 ABC, by the Vienna Business Agency through the project Vienna Cybersecurity and Privacy Research Center (VISP), by the Austrian Federal Ministry for Digital and Economic Affairs, the National Foundation for Research, Technology and Development and the Christian Doppler Research Association through the Christian Doppler Laboratory Blockchain Technologies for the Internet of Things (CDL-BOT).

REFERENCES

- [1] Muneeb Ali, Jude Nelson, Ryan Shea, and Michael J Freedman. 2016. Blockstack : A Global Naming and Storage System Secured by Blockchains. In *USENIX Annual Technical Conference*. <https://doi.org/10.1056/NEJMvcm0706789>
- [2] Frederik Armknecht, Jens-Matthias Bohli, Ghassan O Karame, Zongren Liu, and Christian A Reuter. 2014. Outsourced proofs of retrievability. In *Proceedings of the 2014 ACM SIGSAC Conference on Computer and Communications Security*. ACM, 831–843.
- [3] Giuseppe Ateniese, Michael T. Goodrich, Vassilios Lekakis, Charalampos Papamanthou, Evripidis Paraskevas, and Roberto Tamassia. 2017. Accountable storage. In *Lecture Notes in Computer Science (including subseries Lecture Notes in Artificial Intelligence and Lecture Notes in Bioinformatics)*. https://doi.org/10.1007/978-3-319-61204-1_31
- [4] Giuseppe Ateniese, Seny Kamara, and Jonathan Katz. 2009. Proofs of Storage from Homomorphic Identification Protocols. In *Advances in Cryptology – ASIACRYPT 2009*, Mitsuru Matsui (Ed.). Springer Berlin Heidelberg, Berlin, Heidelberg, 319–333.
- [5] Christian Badertscher, Ueli Maurer, Daniel Tschudi, and Vassilis Zikas. 2017. Bitcoin as a transaction ledger: A composable treatment. In *Advances in Cryptology – CRYPTO 2017: 37th Annual International Cryptology Conference, Santa Barbara, CA, USA, August 20–24, 2017, Proceedings, Part I 37*. Springer, 324–356.
- [6] Juan Benet. 2014. {IPFS} - Content Addressed, Versioned, {P2P} File System. *CoRR* (2014). <https://doi.org/10.1109/ICPADS.2007.4447808> arXiv:arXiv:1407.3561v1
- [7] Juan Benet and Nicola Greco. 2018. Filecoin: A Decentralized Storage Network. *Protocol Labs* (2018). <https://doi.org/10.1088/1126-6708/2007/08/019> arXiv:0611122 [hep-th]
- [8] Iddo Bentov and Ranjit Kumaresan. 2014. How to Use Bitcoin to Design Fair Protocols. In *Advances in Cryptology – CRYPTO 2014*, Juan A. Garay and Rosario Gennaro (Eds.). Springer Berlin Heidelberg, Berlin, Heidelberg, 421–439.
- [9] Joseph Bonneau, Jeremy Clark, and Steven Goldfeder. 2015. On Bitcoin as a public randomness source. *Cryptology ePrint Archive*, Report 2015/1015. <https://eprint.iacr.org/2015/1015>.

- [10] Kevin D. Bowers, Ari Juels, and Alina Oprea. 2009. HAIL. In *Proceedings of the 16th ACM conference on Computer and communications security - CCS '09*. ACM Press, New York, New York, USA, 187. <https://doi.org/10.1145/1653662.1653686>
- [11] Matteo Campanelli, Rosario Gennaro, Steven Goldfeder, and Luca Nizzardo. 2017. Zero-Knowledge Contingent Payments Revisited: Attacks and Payments for Services. In *Proceedings of the 2017 ACM SIGSAC Conference on Computer and Communications Security (Dallas, Texas, USA) (CCS '17)*. ACM, New York, NY, USA, 229–243. <https://doi.org/10.1145/3133956.3134060>
- [12] Ran Canetti. 2000. Security and composition of multiparty cryptographic protocols. *Journal of CRYPTOLOGY* 13 (2000), 143–202.
- [13] David Cash, Alptekin Küpçü, and Daniel Wichs. 2017. Dynamic Proofs of Retrievability Via Oblivious RAM. *Journal of Cryptology* 30, 1 (jan 2017), 22–57. <https://doi.org/10.1007/s00145-015-9216-2>
- [14] Jonathan Dautrich, Elaine Shi, and Emil Stefanov. 2014. Burst ORAM: Minimizing ORAM Response Times for Bursty Access Patterns. In *USENIX Security Symposium*. USENIX, 749–764. <https://www.usenix.org/conference/usenixsecurity14/technical-sessions/presentation/dautrich>
- [15] Yevgeniy Dodis, Salil Vadhan, and Daniel Wichs. 2009. Proofs of Retrievability via Hardness Amplification. In *Proceedings of the 6th Theory of Cryptography Conference on Theory of Cryptography*. Springer-Verlag, 109–127. https://doi.org/10.1007/978-3-642-00457-5_8
- [16] Jack Doerner, Yashvanth Kondi, Eysa Lee, and Abhi Shelat. 2018. Secure two-party threshold ECDSA from ECDSA assumptions. In *2018 IEEE Symposium on Security and Privacy (SP)*. IEEE, 980–997.
- [17] Stefan Dziembowski, Lisa Ekeey, and Sebastian Faust. 2018. FairSwap. In *Proceedings of the 2018 ACM SIGSAC Conference on Computer and Communications Security - CCS '18*. ACM Press, New York, New York, USA, 967–984. <https://doi.org/10.1145/3243734.3243857>
- [18] Stefan Dziembowski, Lisa Ekeey, Sebastian Faust, and Daniel Malinowski. 2019. Perun: Virtual payment hubs over cryptocurrencies. In *2019 IEEE Symposium on Security and Privacy (SP)*. IEEE, 106–123.
- [19] Chris Erway, Alptekin Küpçü, Charalampos Papamanthou, and Roberto Tamassia. 2009. Dynamic provable data possession. In *Proceedings of the 16th ACM conference on Computer and communications security - CCS '09*. ACM Press, New York, New York, USA, 213. <https://doi.org/10.1145/1653662.1653688>
- [20] Ben Fisch. 2018. PoReps: Proofs of Space on Useful Data. *IACR Cryptology ePrint Archive* 2018 (2018), 678.
- [21] Anmin Fu, Yuhan Li, Shui Yu, Yan Yu, and Gongxuan Zhang. 2018. DIPOR: An IDA-based dynamic proof of retrievability scheme for cloud storage systems. *Journal of Network and Computer Applications* 104 (2018), 97 – 106. <https://doi.org/10.1016/j.jnca.2017.12.007>
- [22] Steven D. Galbraith, Kenneth G. Paterson, and Nigel P. Smart. 2008. Pairings for cryptographers. *Discrete Applied Mathematics* 156, 16 (sep 2008), 3113–3121. <https://doi.org/10.1016/j.dam.2007.12.010>
- [23] Yossi Gilad, Rotem Hemo, Silvio Micali, Georgios Vlachos, and Nickolai Zeldovich. 2017. Algorand: Scaling Byzantine Agreements for Cryptocurrencies. In *Proceedings of the 26th Symposium on Operating Systems Principles (Shanghai, China) (SOSP '17)*. ACM, New York, NY, USA, 51–68. <https://doi.org/10.1145/3132747.3132757>
- [24] Don Johnson, Alfred Menezes, and Scott Vanstone. 2001. The Elliptic Curve Digital Signature Algorithm (ECDSA). *International Journal of Information Security* 1, 1 (2001), 36–63. <https://doi.org/10.1007/s102070100002>
- [25] Ari Juels and Burton S Kaliski Jr. 2007. PORs: Proofs of retrievability for large files. In *Proceedings of the Computer and communications security, 14th ACM conference on*. <https://doi.org/10.1145/1315245.1315317>
- [26] Ranjit Kumaresan and Iddo Bentov. 2014. How to Use Bitcoin to Incentivize Correct Computations. In *Proceedings of the 2014 ACM SIGSAC Conference on Computer and Communications Security (Scottsdale, Arizona, USA) (CCS '14)*. Association for Computing Machinery, New York, NY, USA, 30–41. <https://doi.org/10.1145/2660267.2660380>
- [27] Li Li, Xiao Lan, Mali Chen, Ting Luo, Li Chen, Yangxin Wang, and Yumeng Chen. 2022. PPTPS: Building privacy-preserving auditable service with traceable timeliness for public cloud storage. *Plos one* 17, 10 (2022), e0276212.
- [28] Li Li and Jiayong Liu. 2020. SecACS: Enabling lightweight secure auditable cloud storage with data dynamics. *Journal of Information Security and Applications* 54 (2020), 102545. <https://doi.org/10.1016/j.jisa.2020.102545>
- [29] Shanshan Li, Chunxiang Xu, Yuan Zhang, Yicong Du, and Kefei Chen. 2022. Blockchain-based transparent integrity auditing and encrypted deduplication for cloud storage. *IEEE Transactions on Services Computing* (2022).
- [30] Shanshan Li, Chunxiang Xu, Yuan Zhang, Yicong Du, and Kefei Chen. 2023. Blockchain-Based Transparent Integrity Auditing and Encrypted Deduplication for Cloud Storage. *IEEE Transactions on Services Computing* 16, 1 (2023), 134–146. <https://doi.org/10.1109/TSC.2022.3144430>
- [31] Shanshan Li, Chunxiang Xu, Yuan Zhang, Anjia Yang, Xinsheng Wen, and Kefei Chen. 2021. Blockchain-Based Efficient Public Integrity Auditing for Cloud Storage Against Malicious Auditors. In *Information Security and Cryptology: 16th International Conference, Inscrypt 2020, Guangzhou, China, December 11–14, 2020, Revised Selected Papers*. Springer, 202–220.
- [32] Yannan Li, Yong Yu, Ruonan Chen, Xiaojiang Du, and Mohsen Guizani. 2020. IntegrityChain: Provable Data Possession for Decentralized Storage. *IEEE Journal on Selected Areas in Communications* 38, 6 (2020), 1205–1217. <https://doi.org/10.1109/JSAC.2020.2986664>
- [33] Shuqin Liu, Yusong Yao, Guohua Tian, Jianghong Wei, and Xialin Liu. 2023. A blockchain-based compact audit-enabled deduplication in decentralized storage. *Computer Standards & Interfaces* 85 (2023), 103718. <https://doi.org/10.1016/j.csi.2022.103718>
- [34] Ben Lynn. 2019. PBC Library - Pairing-Based Cryptography. <https://crypto.stanford.edu/pbc/>
- [35] Rahul Mishra, Dharavath Ramesh, Salil S Kanhere, and Damodar Reddy Edla. 2022. Enabling Efficient Deduplication and Secure Decentralized Public Auditing for Cloud Storage: A Redactable Blockchain Approach. *ACM Transactions on Management Information Systems* (2022).
- [36] Tal Moran and Ilan Orlov. 2016. Rational Proofs of Space-Time. *Cryptology ePrint Archive*, Report 2016/035. <https://eprint.iacr.org/2016/035>.

- [37] Moni Naor and Guy N. Rothblum. 2009. The complexity of online memory checking. *J. ACM* 56, 1 (jan 2009), 1–46. <https://doi.org/10.1145/1462153.1462155>
- [38] Sanjeet Kumar Nayak and Somanath Tripathy. 2021. SEPDP: Secure and Efficient Privacy Preserving Provable Data Possession in Cloud Storage. *IEEE Transactions on Services Computing* 14, 3 (2021), 876–888. <https://doi.org/10.1109/TSC.2018.2820713>
- [39] Jianbing Ni, Kuan Zhang, Yong Yu, and Tingting Yang. 2022. Identity-Based Provable Data Possession From RSA Assumption for Secure Cloud Storage. *IEEE Transactions on Dependable and Secure Computing* 19, 3 (2022), 1753–1769. <https://doi.org/10.1109/TDSC.2020.3036641>
- [40] Sunoo Park, Albert Kwon, Georg Fuchsbaauer, Peter Gaži, Joël Alwen, and Krzysztof Pietrzak. 2015. SpaceMint: A Cryptocurrency Based on Proofs of Space. Cryptology ePrint Archive, Report 2015/528. <https://eprint.iacr.org/2015/528>.
- [41] Maura B. Paterson, Douglas R. Stinson, and Jalaj Upadhyay. 2016. Multi-prover proof of retrievability. *J. Mathematical Cryptology* 12 (2016), 203–220.
- [42] Reyhaneh Rabaninejad, Mahmoud Ahmadian Attari, Maryam Rajabzadeh Asaar, and Mohammad Reza Aref. 2020. A lightweight identity-based provable data possession supporting users' identity privacy and traceability. *Journal of Information Security and Applications* 51 (2020), 102454. <https://doi.org/10.1016/j.jisa.2020.102454>
- [43] Nakamoto Satoshi and Satoshi Nakamoto. 2008. Bitcoin: A Peer-to-Peer Electronic cash system. *Bitcoin* (2008). <https://doi.org/10.1007/s10838-008-9062-0> arXiv:43543534534v343453
- [44] Binanda Sengupta and Sushmita Ruj. 2016. Publicly Verifiable Secure Cloud Storage for Dynamic Data Using Secure Network Coding. In *Proceedings of the 11th ACM on Asia Conference on Computer and Communications Security (Xi'an, China) (ASIA CCS '16)*. ACM, New York, NY, USA, 107–118. <https://doi.org/10.1145/2897845.2897915>
- [45] Binanda Sengupta and Sushmita Ruj. 2017. Efficient Proofs of Retrievability with Public Verifiability for Dynamic Cloud Storage. *IEEE Transactions on Cloud Computing* PP (10 2017). <https://doi.org/10.1109/TCC.2017.2767584>
- [46] Hovav Shacham and Brent Waters. 2008. Compact Proofs of Retrievability. In *Advances in Cryptology - ASIACRYPT 2008*, Josef Pieprzyk (Ed.). Springer Berlin Heidelberg, Berlin, Heidelberg, 90–107.
- [47] M. Song, Z. Hua, Y. Zheng, H. Huang, and X. Jia. 5555. Blockchain-Based Deduplication and Integrity Auditing over Encrypted Cloud Storage. *IEEE Transactions on Dependable and Secure Computing* 01 (jan 5555), 1–18. <https://doi.org/10.1109/TDSC.2023.3237221>
- [48] Surmila Thokchom and Dilip Kr. Saikia. 2020. Privacy preserving integrity checking of shared dynamic cloud data with user revocation. *Journal of Information Security and Applications* 50 (2020), 102427. <https://doi.org/10.1016/j.jisa.2019.102427>
- [49] Guohua Tian, Yunhan Hu, Jianghong Wei, Zheli Liu, Xinyi Huang, Xiaofeng Chen, and Willy Susilo. 2022. Blockchain-Based Secure Deduplication and Shared Auditing in Decentralized Storage. *IEEE Transactions on Dependable and Secure Computing* 19, 6 (2022), 3941–3954. <https://doi.org/10.1109/TDSC.2021.3114160>
- [50] Nik U. 2022. Golang documentation of PBC library. <https://godoc.org/github.com/Nik-U/pbc>
- [51] David Vorick and Luke Champine. 2014. *Sia: Simple Decentralized Storage*. Technical Report. <https://sia.tech/sia.pdf>
- [52] Cong Wang, Sherman S.M. Chow, Qian Wang, Kui Ren, and Wenjing Lou. 2013. Privacy-Preserving Public Auditing for Secure Cloud Storage. *IEEE Trans. Comput.* 62, 2 (feb 2013), 362–375. <https://doi.org/10.1109/TC.2011.245>
- [53] Hao Wang, Hong Qin, Minghao Zhao, Xiaochao Wei, Hua Shen, and Willy Susilo. 2020. Blockchain-based fair payment smart contract for public cloud storage auditing. *Information Sciences* 519 (2020), 348–362.
- [54] Yujue Wang, Qianhong Wu, Bo Qin, Shaohua Tang, and Willy Susilo. 2017. Online/Offline Provable Data Possession. *IEEE Transactions on Information Forensics and Security* 12 (2017), 1182–1194.
- [55] Yujue Wang, Qianhong Wu, Duncan S. Wong, Bo Qin, Sherman S. M. Chow, Zhen Liu, and Xiao Tan. 2014. Securely Outsourcing Exponentiations with Single Untrusted Program for Cloud Storage. In *ESORICS*.
- [56] Shawn Wilkinson, Tome Bosheviski, Josh Brandoff, James Prestwich, Gordon Hall, Patrick Gerbes, Philip Hutchins, and Chris Pollard. 2014. *Storj A Peer-to-Peer Cloud Storage Network*. Technical Report. <https://doi.org/10.1016/j.appdev.2004.09.001>
- [57] Gavin Wood. 2014. Ethereum: A Secure Decentralised Generalised Transaction Ledger EIP-150 Revision. In *Ethereum Project Yellow Paper*. <https://doi.org/10.1017/CBO9781107415324.004> arXiv:arXiv:1011.1669v3
- [58] Mande Xie, Qiting Zhao, Haibo Hong, Chen Chen, and Jun Yu. 2022. A novel blockchain-based and proxy-oriented public audit scheme for low performance terminal devices. *J. Parallel and Distrib. Comput.* 169 (2022), 58–71.
- [59] Yang Xu, Cheng Zhang, Guojun Wang, Zheng Qin, and Quanrun Zeng. 2020. A blockchain-enabled deduplicatable data auditing mechanism for network storage services. *IEEE Transactions on Emerging Topics in Computing* 9, 3 (2020), 1421–1432.
- [60] Zhiyan Xu, Debiao He, Huaqun Wang, Pandi Vijayakumar, and Kim-Kwang Raymond Choo. 2020. A novel proxy-oriented public auditing scheme for cloud-based medical cyber physical systems. *Journal of Information Security and Applications* 51 (2020), 102453. <https://doi.org/10.1016/j.jisa.2020.102453>
- [61] Yang Yang, Yanjiao Chen, Fei Chen, and Jing Chen. 2022. An Efficient Identity-Based Provable Data Possession Protocol With Compressed Cloud Storage. *IEEE Transactions on Information Forensics and Security* 17 (2022), 1359–1371. <https://doi.org/10.1109/TIFS.2022.3159152>
- [62] J. Yuan and S. Yu. 2014. Efficient public integrity checking for cloud data sharing with multi-user modification. In *IEEE INFOCOM 2014 - IEEE Conference on Computer Communications*. 2121–2129.
- [63] Dongdong Yue, Ruixuan Li, Yan Zhang, Wenlong Tian, and Yongfeng Huang. 2020. Blockchain-based verification framework for data integrity in edge-cloud storage. *J. Parallel and Distrib. Comput.* 146 (2020), 1–14.

- [64] Cheng Zhang, Yang Xu, Yupeng Hu, Jiajing Wu, Ju Ren, and Yaoxue Zhang. 2021. A blockchain-based multi-cloud storage data auditing scheme to locate faults. *IEEE Transactions on Cloud Computing* 10, 4 (2021), 2252–2263.
- [65] Yuan Zhang, Chunxiang Xu, Jining Zhao, Xiaojun Zhang, and Junwei Wen. 2015. Cryptanalysis of an integrity checking scheme for cloud data sharing. *Journal of Information Security and Applications* 23 (2015), 68 – 73. <https://doi.org/10.1016/j.jisa.2015.05.001>