

A lightweight BFT consensus protocol for blockchains

Jan Hackfeld
Lightcurve GmbH
jan.hackfeld@lightcurve.io

March 30, 2022

Abstract

We present a general consensus framework that allows to easily introduce a customizable Byzantine fault tolerant consensus algorithm to an existing (delegated) proof-of-stake blockchain. We prove the safety of the protocol under the assumption that less than $1/3$ of the block proposers are Byzantine. The framework further allows for consensus participants to choose subjective decision thresholds in order to obtain safety even in the case of a larger proportion of Byzantine block proposers. Moreover, the liveness of the protocol is shown if less than $1/3$ of the block proposers crash.

Based on the framework, we introduce LISK-BFT, a Byzantine fault tolerant consensus algorithm for the Lisk blockchain. LISK-BFT integrates with the existing block proposal, requires only two additional integers in block headers and no additional messages. The protocol is simple and provides safety in the case of static proposers if less than $1/3$ of the block proposers are Byzantine. For the case of dynamically changing proposers, we prove the safety of the protocol assuming a bound on the number of Byzantine proposers and the number of honest proposers that can change at one time. We further show the liveness of the LISK-BFT protocol for less than $1/3$ crashing block proposers.

1 Introduction

The Paxos protocol introduced by Lamport in [12] is the basis for most consensus protocols solving the Byzantine agreement or more generally the state machine replication problem. Starting with [6], there has been a multitude of different practical consensus protocols that adapt the basic Paxos protocol to improve various aspects such as the efficiency and the resistance against Byzantine faults. See [14] for a classification of different consensus protocols.

In this paper, we introduce LISK-BFT, a Byzantine fault tolerant consensus algorithm for the Lisk blockchain that follows this line of research. We assume that there is a set of block proposers that can add blocks to a block tree via a given proposal mechanism (e.g. round-robin). Ideally, we would like the block proposers to propose one block after another always referencing the previously proposed block via a directed edge and hence forming a tree with only one growing branch, i.e., a blockchain. However, due to the latency of communication between the block proposers or deliberate attacks on the network, there can be multiple child blocks of the same parent block and separate growing branches. We therefore need a consensus protocol for block proposers to agree on one block at every height of the block tree.

We distinguish between *honest* block proposers that correctly follow the consensus protocol and *Byzantine* block proposers that may behave arbitrarily. The consensus algorithm is

supposed to allow block proposers to *decide* for exactly one block at every height of the block tree such that the following properties are satisfied:

- **Safety.** Two honest block proposers never decide for *conflicting* blocks, i.e., blocks that are not contained in one branch of the block tree.
- **Liveness.** An honest block proposer eventually decides for a block at any height.
- **Accountability.** A block proposer can detect if a Byzantine block proposer violates the consensus protocol and can identify the Byzantine block proposer.

Note that the safety property implies that all decided blocks for an honest block proposer are in one branch of the block tree and for any height two honest block proposers never decide for distinct blocks.

In the case of Bitcoin [13], consensus is reached by block proposers choosing the chain which required the most “work”. This rule does not satisfy both the safety and liveness property above because no matter how late a block proposer decides for a block B , there is no guarantee that the block B will be contained in the Bitcoin blockchain the Bitcoin network agrees on in the future. The reason is that there always can be a different branch of the Bitcoin block tree in the future with more “work” although for economic reasons it becomes increasingly unlikely the more blocks are added to the block tree as descendants of B .

Tendermint [1] is one of the first blockchain consensus protocols achieving the safety, liveness and accountability property above. Namely, Tendermint guarantees that as long as $< 1/3$ of the block proposers are Byzantine, both the safety and liveness property hold, which is optimal for the partially synchronous system model introduced in [7]. The Tendermint protocol proceeds in three distinct phases. Once the three phases are completed successfully, the block proposers decide for a block B and proceed with proposing and deciding for a descendant of B . This way the block tree in Tendermint is simply a path as for every height the block proposers decide for a block before proceeding further. We call a consensus protocol with this property *fork-free*. In contrast to that, we refer to a consensus protocol as *forkful* if there is no requirement for block proposers to achieve consensus, i.e., decide for a block, before adding further blocks to the block tree.

The LISK-BFT protocol is a forkful protocol, where the block proposal can independently progress before consensus is reached on blocks. This idea of using *speculative Byzantine fault tolerance* in order to decrease the overhead has already been considered in [11] for the state machine replication problem. We also believe that a forkful protocol can achieve better performance in practice and significantly decrease the communication overhead as consensus can be reached independent of the block proposal at any later point in time. For a more detailed treatment of forkful versus fork-free consensus protocols and the message complexity involved, see [3].

2 Model and definitions

In this section, we introduce the blockchain specific terminology as well as the underlying network model. We do not consider the general state machine replication problem, but instead assume that there is a block proposal mechanism, where time is divided into discrete slots and for every time slot there is a designated block proposer. We also change some of the state machine replication terminology to the blockchain specific context.

A *block tree* is a directed tree with a designated root vertex referred to as *genesis block* and a unique directed path from every vertex in the block tree to the genesis block. We refer to the vertices in the block tree as *blocks*. We assume that blocks can contain arbitrary data such as signatures or messages. Every block B has a corresponding *height*, denoted by $h(B)$, which is the number of edges of the unique path from that block to the genesis block. Note that the genesis block has height 0. For a block B in the block tree, we call a block B' *ancestor* if B' is distinct from B and is on the directed path from B to the genesis block. Moreover, B' is called a *descendant* of B if B is an ancestor of B' . If there is a directed edge from a block B to a block B' , then B' is called the *parent* of B and B a *child* of B' . We further refer to the subgraph induced by a path from a block without child to the genesis block as a *branch* or a *chain*. For a given chain, the unique block without child block is referred to as the *tip* or *head* of the chain. Two blocks are called *conflicting* if they are not contained in one branch of the block tree, i.e., none is a descendant of the other.

We assume that there is a set $\mathcal{P} = \{P_1, P_2, \dots, P_n\}$ of n *block proposers* and a *proposal mechanism* for block proposers to add child blocks of existing blocks to the block tree. We distinguish between three types of proposers: A block proposer is *honest* if it follows the consensus protocol. A block proposer is further called *offline* or *crashed* if it does not participate in the consensus protocol, i.e., does not send any message to the network. Moreover, a *Byzantine* block proposer can behave arbitrarily, e.g., maliciously violate the consensus protocol or crash. Classic Byzantine fault tolerance consensus protocols typically yield guarantees assuming certain upper bounds on the number of Byzantine block proposers. In the case of blockchain, in particular proof-of-stake, we would rather have guarantees in terms of the stake represented by a certain set of block proposers. We can model this by associating a weight $\omega_P \in (0, 1]$ to every block proposer P such that $\sum_{P \in \mathcal{P}} \omega_P = 1$, where ω_P can be thought of as the relative stake in the case of a proof-of-stake blockchain. For the simplicity of exposition, we never explicitly use the weights of the block proposers but rather say that $> \omega$ (or $< \omega$) of the block proposers satisfy a property X if the set M of block proposers satisfying property X has overall weight larger (or smaller) than ω , i.e., $\sum_{P \in M} \omega_P > \omega$ ($\sum_{P \in M} \omega_P < \omega$). For instance, we regularly assume that $< 1/3$ of the block proposers are Byzantine. For the Lisk blockchain we have $n = 101$ block proposers and uniform weights $\omega_P = 1/101$ for all $P \in \mathcal{P}$ and the round-robin block proposal scheme currently used for the Lisk blockchain satisfies that block proposers are assigned slots proportional to their weight. The proposal mechanism could, however, also be based on randomized leader election proportional to stake, for instance.

We further assume that the block proposers communicate by exchanging messages via the underlying network. We model the network using the *partially synchronous system model* introduced in [7]. The basic assumption of this model is that in general the network can behave arbitrarily badly, i.e., messages are lost or have a huge delay, but eventually, from a time GST onward, the network behaves nicely, i.e., all messages arrive reliably and with a delay of at most Δ . The parameter GST is called the *global stabilization time*. Messages are further always signed so that a block proposer can not be impersonated by another block proposer. The block proposers are not required to know any bound on GST or Δ . Note that the eventually synchronous network is only necessary to show the liveness of the consensus algorithm, but not for the safety. In fact, this assumption on the underlying network is stronger than needed for our consensus to work in practice and our results can easily be extended to a network model with regular long enough good time periods, where the messages arrive reliably and within Δ time. These good periods only need to be long enough for block proposers to send enough messages to decide for blocks. For the ease of exposition, however, we use the partially

synchronous system model.

Note that due to the impossibility results of Fischer et al. [9, 8], stating that consensus is impossible without randomization in an asynchronous message-passing system with at least one Byzantine or crashing node, the partially synchronous system model is one of the weakest models where consensus without randomization is possible. Known consensus algorithms for asynchronous systems using randomization have worse guarantees in terms of maximum number of Byzantine block proposers, a large number of local computations or a larger number of messages [5, 10].

3 General consensus algorithm framework

In this section, we define a general consensus protocol with two types of messages, which is later used as the basis for the LISK-BFT protocol.

3.1 Protocol rules

We now describe the protocol rules of the general consensus framework. A proposer P can send two types of messages, $\text{PREVOTE}(B, T, P)$ and $\text{PRECOMMIT}(B, T, P)$, where B and T are blocks in the block tree such that $T = B$ or T is a descendant of B (T is typically the tip of the current chain of P). In an implementation, B and T can be block hashes and P the public key and signature of the block proposer P . We assume that both types of messages are added to the blocks so that we can refer to the *prevotes* and *precommits* included in the blockchain from the genesis block up to the tip T . Moreover, we shortly write that a block proposer prevotes for B if P sends a $\text{PREVOTE}(B, T, P)$ message and equivalently that P precommits for B if it sends a message $\text{PRECOMMIT}(B, T, P)$ for a block T . Next, we describe the protocol rules that must be satisfied when sending prevote and precommit messages and the conditions for block proposers to decide for blocks.

Definition 3.1. The prevotes and precommits send by a block proposer $P \in \mathcal{P}$ must obey the following rules:

- (I) For any two distinct messages $\text{PREVOTE}(B, T, P)$ and $\text{PREVOTE}(B', T', P)$, it holds that $h(B) \neq h(B')$.
- (II) For any message $\text{PRECOMMIT}(B, T, P)$, the blockchain up to block T must include both
 - (a) one $\text{PREVOTE}(B, \cdot, P)$ message and
 - (b) $\text{PREVOTE}(B, \cdot, \cdot)$ messages by $> 2/3$ of the block proposers.
- (III) For any two messages $\text{PRECOMMIT}(B, T, P)$ and $\text{PREVOTE}(B', T', P)$ with $h(B) < h(B')$ at least one of the following conditions is satisfied:
 - (a) B' is a descendant of B .
 - (b) The blockchain up to T' contains a block \bar{B} at height $h(\bar{B}) \geq h(B)$ and $\text{PREVOTE}(\bar{B}, \cdot, \cdot)$ messages by $> 2/3$ of the block proposers.

Let $\tau_P \in (\frac{1}{3}, 1]$ denote the *decision threshold* of a block proposer P . Once proposer P receives $\text{PRECOMMIT}(B, \cdot, \cdot)$ messages by $> \tau_P$ of the proposers, proposer P *decides for* block B or *finalizes* block B . This implies that P also decides for all ancestors of B .

The basic intuition behind the protocol rules is that prevotes must not contradict, so block proposers can cast only one prevote for every height by (I). Moreover, in order to send a precommit for a block, a proposer has to have send a prevote for that block and received prevotes by $> 2/3$ of the block proposers for it due to (II). Finally, the intuition behind (III) is that a block proposer cannot change to a different chain without a justification, i.e., after a precommit for block B , all prevotes of larger height must be for descendants of B or as a justification there is a block \bar{B} at height $h(\bar{B}) \geq h(B)$ with $> 2/3$ prevotes that allows the block proposer to start sending prevotes on a different chain.

In the next subsection, we show how the decision threshold relates to the safety property of the protocol. Intuitively, the higher the decision threshold of the block proposers, the more block proposers can be Byzantine without losing the safety property. On the other hand, for the liveness property, the decision threshold cannot be too high as otherwise a proposer may never decide on a block.

3.2 Safety

In this section, we show that the safety property is fulfilled for the general consensus protocol assuming a bound on the overall weight of Byzantine block proposers that depends on the decision thresholds of the block proposers.

Theorem 3.2 (Safety). *If there are $< (\tau - 1/3)$ Byzantine block proposers for $\tau \in (1/3, 1]$, then any two honest block proposers with decision threshold at least τ never decide for conflicting blocks.*

Proof. Assume, for the sake of contradiction, that there are two conflicting blocks A and B as well as an honest block proposer P_A with decision threshold τ_A deciding for A and an honest block proposer P_B with decision threshold τ_B deciding for B . Without loss of generality let $h(A) \leq h(B)$. Note that by assumption we have $\tau \leq \tau_A$ and $\tau \leq \tau_B$.

If P_A decides for A , it must have received a $\text{PRECOMMIT}(A, \cdot, \cdot)$ messages by $> \tau_A$ of the block proposers by definition. By assumption, $\tau_A \geq \tau$ and $< (\tau - 1/3)$ of the block proposers are Byzantine so that there is a set of $> 1/3$ honest block proposers \mathcal{P}_A that must have sent a $\text{PRECOMMIT}(A, \cdot, \cdot)$ message. In particular, by property (I), no proposer $P \in \mathcal{P}_A$ sends a $\text{PREVOTE}(A', \cdot, P)$ message for a distinct block A' at height $h(A)$ and hence no distinct block A' at height $h(A)$ can receive $> 2/3$ prevotes. This also implies that we cannot have $h(A) = h(B)$ as there can only be $\leq 2/3$ prevotes for B and hence no honest block proposer P would send a $\text{PRECOMMIT}(B, \cdot, P)$ message by (II). Thus, the threshold of τ_B precommit messages for block B cannot be reached and we must have $h(A) < h(B)$.

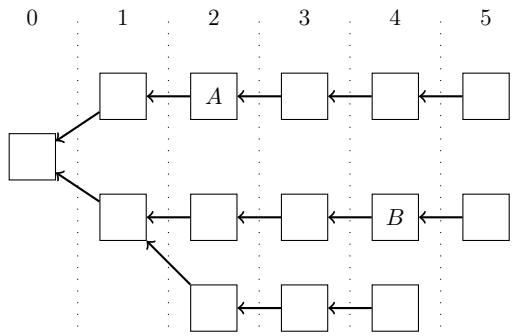

Figure 1: Block tree with two contradicting blocks A and B .

By (III), every block proposer $P \in \mathcal{P}_A$ is only allowed to send a prevote message for a block that is not a descendant of A if there is a block \bar{B} at height $h(\bar{B}) \geq h(A)$ with $\text{PREVOTE}(\bar{B}, \cdot, \cdot)$ messages by $> 2/3$ of the block proposers. As all block proposers in \mathcal{P}_A are honest, there have to be $> 2/3$ prevotes for such a block \bar{B} by block proposers not in \mathcal{P}_A . This is a contradiction, as \mathcal{P}_A is a set of $> 1/3$ block proposers by assumption. Hence, no block that is not a descendant of A can obtain $> 2/3$ prevotes and thus no honest block proposer sends a precommit for B . This means that the decision threshold of τ_B precommit messages for block B cannot be reached contradicting that the honest block proposer P_B decided for B . \square

Remark. Note that for $\geq 1/3$ Byzantine block proposers consensus that guarantees both safety and liveness in the partially synchronous system model is impossible as shown in [7]. This is also the case for the consensus framework above because Byzantine block proposers can for example not send any prevotes and thus prevent any decision for a block as the threshold of $> 2/3$ prevotes is not reached. In order to have both the liveness and safety property, we hence cannot have $\geq 1/3$ Byzantine block proposers. The purpose of the flexible subjective decision threshold is to allow for optimistic participants (those assuming a small fraction of Byzantine block proposers) to decide for blocks earlier by only requiring a small decision threshold τ_P . On the other hand, pessimistic participants can decide for a block only with a very high decision threshold (with the risk of never making a decision if too many block proposers are Byzantine or offline) with the guarantee that $\geq \tau_P - 1/3$ must violate the protocol rules for a conflicting block to be decided. In particular, in the case that slashing conditions are added to punish Byzantine proposers by burning their deposits, this allows to choose a decision threshold depending on the desired safety guarantee in terms of deposit at stake.

3.3 Liveness

For proving the liveness condition of the consensus framework from Definition 3.1, we rely on the partially synchronous system model. Recall that the basic assumption is that after the global stabilization time of GST, all messages arrive reliably with a delay of at most Δ . We assume that the time slots for block proposers to add blocks to the block tree have a duration of at least 2Δ . This way the underlying network is fast enough for the message about a new block to reach every block proposer and all block proposers to send new prevote and precommit messages that reach every other block proposer before the next block is proposed. This way, all prevotes and precommits can be included in the next block and block proposers at regular

times have the same information about the block tree (we assume that blocks, prevote and precommit messages that were lost before time GST are simply rebroadcast).

Additionally, for the liveness property to hold, block proposers need to follow the same *fork choice rule*, i.e., a rule that defines how the block proposers choose one branch of the block tree as their current chain. More precisely, a fork choice rule is a function f that, given the block tree \mathcal{T}_P of block proposer P (i.e., the block tree containing all blocks received by block proposer P) and the arrival times of all blocks as input, returns one branch of the block tree \mathcal{T}_P . We refer to this branch as the *canonical chain* of \mathcal{T}_P . We say that a block proposer P follows a fork choice rule f if it adds new proposed blocks to the canonical chain and only sends prevote and precommit messages for blocks in the canonical chain. For the liveness proof, we use the fork choice rule defined below.

Definition 3.3 (LONGEST-CHAIN). Let \mathcal{T}_P be the current block tree of block proposer P and \bar{h} be the largest height of a block in \mathcal{T}_P with prevotes by $> 2/3$ of the block proposers included in one branch of \mathcal{T}_P . Then the LONGEST-CHAIN fork choice rule returns the longest branch that contains a block \bar{B} at height \bar{h} and PREVOTE(\bar{B}, \cdot, \cdot) messages by $> 2/3$ of the block proposers. Ties are broken in favor of the complete chain received first.

The essential property that the fork choice rule needs to satisfy is that the branch returned always contains a block \bar{B} of largest height with prevote messages by $> 2/3$ of the block proposers. The reason is that by (III), once a block proposer casts a precommit for \bar{B} , it can only prevote and precommit for blocks on the same branch as \bar{B} (unless there is a block of height at least $h(\bar{B})$ with $> 2/3$ prevotes). Thus, by requiring the canonical chain to include \bar{B} , the block proposers automatically satisfy (III) when casting prevotes and precommits. In general, other fork choice rules that satisfy that the canonical chain always contains \bar{B} are possible and yield the liveness property. An example is *Immediate message-driven GHOST* proposed for Ethereum [2].

If $< 1/3$ of the block proposers are Byzantine, there can be at most one block at a given height with $> 2/3$ prevotes by the the block proposers by (I). Thus, in this case \bar{B} in the definition above is unique. Further, note that the tie-breaking in favor of the chain seen first is rather arbitrary and also block hashes, i.e., identifiers associated with every block, can be used. The main point of the tie-breaking is to have a rule that quickly makes the block tree change to a state (by the new proposed blocks) where there are no more ties.

In the following theorem, we show liveness assuming a bound on the weight of crashed block proposers. The reason for not considering Byzantine block proposers is that this would require to make stronger assumptions on the block proposal mechanism. Furthermore, for a concrete application of the general consensus framework it is usually necessary to show liveness again for the concrete block proposal mechanism and additional rules how block proposers send prevote and precommit messages.

Theorem 3.4 (Liveness). *Assume that $< 1/3$ of the block proposers crash and all other block proposers honestly follow the general consensus protocol and LONGEST-CHAIN fork choice rule. Then for any $l \in \mathbb{N}$, an honest block proposer P with decision threshold $\tau_P \in (1/3, 2/3]$ will eventually decide on a block at height l .*

Proof. Consider an arbitrary set of blocks proposed and prevotes as well as precommits cast by all proposers with $> 2/3$ of the block proposers honestly following the consensus protocol from Definition 3.1. Assume that we have reached time GST + 2Δ . This means that all

messages arrive reliably within time Δ and all previously lost messages have been broadcast again and received by all proposers. In particular, the block tree \mathcal{T}_P at the beginning of every block proposal time slot is the same for every block proposer P . Note that due to lost or delayed messages before time GST, there can initially be multiple chains of the same length that contain a block of largest height with prevotes by $> 2/3$ of the block proposers. Because of different arrival times of blocks, block proposers could decide for different canonical chains. However, after the first block is proposed, these ties are broken and the LONGEST-CHAIN rule yields the same canonical chain for every honest delegate.

Let $l \in \mathbb{N}$ and h_{\max} be the largest height that any honest block proposer cast a prevote for. We show that an honest block proposer P with decision threshold $\tau_P \in (1/3, 2/3]$ will eventually decide on a block at height l . The canonical chain of all honest block proposers continues growing until there are two consecutive blocks B_1 and B_2 added to the chain with $h(B_i) > \max\{l, h_{\max}\}$ for $i = 1, 2$.

We first show that any honest block proposer P can send a $\text{PREVOTE}(B_1, \cdot, P)$ message. Assume P previously cast a precommit message for a block B' . We show that the precommit for B' does not prevent P to prevote for B_1 . By assumption, B_1 was added to the chain that contains the block of largest height \bar{B} for which $> 2/3$ of the block proposers cast prevotes (at the time when B_1 is added to the chain). If B' is on a branch not containing \bar{B} , then by (III) proposer P can prevote for B_1 because we have $h(B') < h(\bar{B})$ as B' must have $> 2/3$ prevotes and \bar{B} is the block of largest height with $> 2/3$ prevotes. Note that there can be at most one block at every height with $> 2/3$ prevotes because of (I) and the fact that $> 2/3$ of the block proposers honestly follow the protocol. If B' is on the same branch as \bar{B} , then by the choice of \bar{B} either $B' = \bar{B}$ or B' is an ancestor of \bar{B} . In both cases, the precommit for B' allows P to prevote for any descendants of B' , in particular, for B_1 . Thus, P can prevote for B_1 .

Therefore, all $> 2/3$ honest block proposers can send $\text{PREVOTE}(B_1, \cdot, \cdot)$ messages and these messages reach all block proposers before the next block is proposed because we assume that the block proposal time slots have duration $> 2\Delta$. This means that the honest proposer of B_2 can include these prevote messages for B_1 into the block B_2 . After receiving B_2 , all honest block proposers can now send a $\text{PRECOMMIT}(B_1, \cdot, \cdot)$ messages. Hence, B_1 receives precommits by $> 2/3$ of the block proposers and any block proposer with decision threshold $\tau \in (1/3, 2/3]$ will decide for B_1 and all ancestors of B_1 . In particular, any honest block proposer will decide for a block at height l since $h(B_1) > l$. This shows the claim. \square

3.4 Accountability

We assume that all messages $\text{PREVOTE}(B, T, P)$ and $\text{PRECOMMIT}(B, T, P)$ are signed by the block proposer P . Using the current chain up to block T , any block proposer can verify if the messages sent by a block proposer P satisfy the consensus protocol rules (I)–(III). Note that we assume that it is impossible that a block proposer sends a message exclusively to one honest block proposer without all other block proposers eventually being able to learn about it, as the underlying peer-to-peer network will gossip the messages to all block proposers.

3.5 Lightweight consensus messages

In this section, we describe how multiple prevote and precommit messages can be concisely expressed via a single message, which we call an *approve* message. An $\text{APPROVE}(k, p, T, P)$ message contains a block T , two integers $k, p \in \mathbb{N}$ with $k < h(T)$ and $p < h(T)$ as well as

the block proposer P sending the message. In an implementation, T can be the hash of the block T and P the public key and signature of the message by block proposer P . Moreover, for the message $\text{APPROVE}(k, p, T, P)$ to be valid, p must be the height of the block \bar{B} of largest height that is an ancestor of T and the chain up to T includes prevotes by $> 2/3$ of the block proposers for \bar{B} . As a convention, we assume that the genesis block has prevotes by all block proposers. The height p can be viewed as redundant information that can be derived from the chain up to block T . However, it is essential for a simple expression of the protocol rules and short proofs of any violation of the protocol rules. We now state the rules that block proposers must satisfy when sending approve messages.

Definition 3.5 (MONOTONICITY-RULE). The approve messages by a block proposer P satisfy the MONOTONICITY-RULE if for any two distinct messages $\text{APPROVE}(k, p, T, P)$ and $\text{APPROVE}(k', p', T', P)$ with $k \leq k'$ the following conditions are satisfied:

- (i) It holds that $h(T) \leq k'$.
- (ii) We have $p \leq p'$.

Let B_0, B_1, \dots, B_l be the current chain of block proposer P and $T = B_r$ for $r \in \{0, 1, \dots, l\}$. Then the intuition behind an $\text{APPROVE}(k, p, T, P)$ message is that P approves the blocks $B_{k+1}, B_{k+1}, \dots, B_r$. We require that $k < h(T)$ holds, such that a non-empty set of blocks up to block T is approved. Now, condition (i) of the MONOTONICITY-RULE requires two approve messages to be for blocks with disjoint sets of heights. Note that, in particular, we cannot have $k = k'$ for two distinct messages as otherwise we would obtain $h(T) > k = k'$. Moreover, (ii) ensures that a block proposer only switches to another chain extending a different block with $> 2/3$ prevotes if that block has no smaller height.

We now describe how an approve message translates to prevote and precommit messages.

Definition 3.6. Let B_0, B_1, \dots, B_l be one branch of the block tree of proposer P . Then an $\text{APPROVE}(k, p, B_r, P)$ message with $r \in \{k + 1, \dots, l\}$ implies the following prevotes and precommits:

- (a) P casts a $\text{PREVOTE}(A, B_r, P)$ for every block $A \in \{B_{k+1}, B_{k+2}, \dots, B_r\}$.
- (b) Considering the prevotes and precommits included in the chain $C = B_0, B_1, \dots, B_r$ (given via approve messages), let

$$\begin{aligned} j_1 &:= \max(\{0 \leq s \leq r \mid \exists \text{PRECOMMIT}(B_s, \cdot, P) \text{ in chain } C\} \cup \{-1\}) \\ j_2 &:= \max(\{0 \leq s \leq k \mid \nexists \text{PREVOTE}(B_s, \cdot, P) \text{ in chain } C\} \cup \{-1\}) \\ j &:= \max\{j_1, j_2\} + 1. \end{aligned}$$

Then P casts a $\text{PRECOMMIT}(A, B_r, P)$ for every block A in the set $\{B_j, \dots, B_r\}$ that has (implied) prevotes by $> 2/3$ of the block proposers included in the chain C .

The idea is that the block proposer approves the blocks $B_{k+1}, B_{k+2}, \dots, B_r$ by prevoting for them. Moreover, proposer P sends a maximum number of precommits for blocks starting from its previous precommit while satisfying protocol rule (II). Note that for the precommits in (b), it is important that only the prevotes in the chain C and not those cast in (a) are taken into account, so that for any $\text{PRECOMMIT}(A, B_r, P)$ we have $h(A) \leq p$. This property is needed in the proof of Lemma 3.7.

Next, we show that if a block proposer satisfies the MONOTONICITY-RULE for the approve messages, then the implied prevote and precommit messages satisfy the protocol rules from Definition 3.1.

Lemma 3.7. *If the approve messages by a block proposer P satisfies the MONOTONICITY-RULE and P sends no additional prevote or precommit messages, then the prevotes and precommits implied by the transformation in Definition 3.6 satisfy the protocol rules (I)–(III).*

Proof. Consider two messages $\text{APPROVE}(k, p, T, P)$ and $\text{APPROVE}(k', p', T', P)$ with $k \leq k'$. Because of condition (i) of the MONOTONICITY-RULE, we have $h(T) \leq k'$ and thus

$$\{k + 1, k + 2, \dots, h(T)\} \cap \{k' + 1, k' + 2, \dots, h(T')\} = \emptyset.$$

Therefore all prevotes are cast for blocks at distinct heights, i.e., (I) is satisfied.

Next, consider an arbitrary $\text{PRECOMMIT}(A, B_r, P)$ that is cast according to the transformation of an $\text{APPROVE}(k, p, B_r, P)$ message, where we use the notation from Definition 3.6. We then have $A \in \{B_j, B_{j+1}, \dots, B_r\}$, where $j = \max\{j_1, j_2\} + 1$. As $j_2 < j$, proposer P must have cast a prevote for A and by definition of the transformation there are $\text{PREVOTE}(A, \cdot, \cdot)$ messages by $> 2/3$ of the block proposers included in the chain up to B_r . Hence, (II) is satisfied for all precommit messages.

Finally, consider a $\text{PRECOMMIT}(A, T, P)$ message and a $\text{PREVOTE}(A', T', P)$ message with $h(A) < h(A')$. If A' is a descendant of A , then (III) (a) is satisfied. Otherwise, we must show that (III) (b) is satisfied, i.e., there exists a block \bar{B} at height $h(\bar{B}) \geq h(A)$ with $\text{PREVOTE}(\bar{B}, \cdot, \cdot)$ messages by $> 2/3$ of the block proposers contained in the blockchain up to T' .

From now on, assume that (III) (a) does not hold. Then both $\text{PRECOMMIT}(A, T, P)$ and $\text{PREVOTE}(A', T', P)$ cannot be implied by the same message $\text{APPROVE}(k, p, T, P)$, as otherwise A' is a descendant of A . Thus, there have to be two distinct messages $\text{APPROVE}(k, p, T, P)$ and $\text{APPROVE}(k', p', T', P)$ such that the first implies the message $\text{PRECOMMIT}(A, T, P)$ and the second implies the message $\text{PREVOTE}(A', T', P)$. As $\text{PREVOTE}(A', T', P)$ is implied by $\text{APPROVE}(k', p', T', P)$, we must have $k' < h(A') \leq h(T')$. For the sake of contradiction, let us assume that $k \geq k'$. Then the branch up to T cannot contain any implied prevote by P for a block at height $h(A')$, because we assume that this branch does not contain A' (otherwise again A' is a descendant of A), P already send a $\text{PREVOTE}(A', T', P)$ message on a different branch and (I) is satisfied. Using the notation from Definition 3.6, this implies that $j_2 \geq h(A')$ for the chain C up to T . Therefore any precommit implied by the message $\text{APPROVE}(k, p, T, P)$ must be for blocks at height larger than $h(A')$. This would mean $h(A) > h(A')$, a contradiction. Hence, we must have $k < k'$.

As $k < k'$ holds, we must have $p \leq p'$ by condition (ii) of the MONOTONICITY-RULE. Note that we must have $h(A) \leq p$ as p is the largest height of a block with prevotes by $> 2/3$ of the block proposers included in the chain up to T . Let \bar{B} be the block at height p' that is an ancestor of T' . We have $h(A) \leq p \leq p' = h(\bar{B})$ and there are $\text{PREVOTE}(\bar{B}, \cdot, \cdot)$ messages by $> 2/3$ of the block proposers contained in the blockchain up to T' . Thus, (III) is also satisfied. \square

By Lemma 3.7, the protocol rules (I)–(III) are satisfied when block proposers cast prevotes and precommits implicitly via approve messages. This means that also Theorem 3.2 holds for the case that block proposers only use approve messages for the consensus algorithm.

Corollary 3.8. *Assume for the consensus algorithm block proposers only use approve messages that are transformed according to Definition 3.6 and for any honest proposer the approve messages satisfy the MONOTONICITY-RULE. If there are $< (\tau - 1/3)$ Byzantine block proposers for $\tau \in (1/3, 1]$, then any two honest block proposers with decision threshold at least τ never decide for conflicting blocks.*

3.6 Dynamic set of block proposers

So far, we only considered a static set of block proposers \mathcal{P} . In blockchains, however, this set is typically changing over time as block proposers may want to stop participating in proof-of-stake and withdraw their deposit or different delegates get voted in the top ranks in a delegated proof-of-stake system. The interesting question is what the implications of a dynamically changing set of block proposers are for the safety and liveness guarantees from the last sections.

One approach is that a change of block proposers (e.g., because of withdrawals, deposits or votes) is always possible and comes into effect without requiring any finality, i.e., without requiring that the block or a descendant of the block containing the information of the change of block proposers receives precommits by a certain threshold of block proposers. We discuss this approach and prove some weaker safety guarantees for it.

Due to efficiency reasons, we only allow the set of block proposers to change at certain heights and group blocks into *rounds*. We assume there is a constant $m \in \mathbb{N}_{>0}$ such that for every $r \in \mathbb{N}$ the set of m integers $\{r \cdot m, r \cdot m + 1, \dots, r \cdot m + m - 1\}$ are associated with one round. We then say that for a branch B_0, B_1, \dots, B_l of the block tree, where B_i has height i , the m blocks $B_{r \cdot m}, B_{r \cdot m + 1}, \dots, B_{r \cdot m + m - 1}$ belong to round r . We further refer to $B_{r \cdot m}$ as the first block of round r and to $B_{r \cdot m + m - 1}$ as the last block of round r . Considering one branch of the block tree, the blocks of one round have an associated *active* set of block proposers \mathcal{P} , i.e., only a block proposer in the active set of block proposers \mathcal{P} for a round r is allowed to propose blocks and cast prevotes and precommits for the blocks of round r .

Furthermore, apart from a change in block proposers, it can happen that the weight ω_P associated with a block proposer P changes (e.g., due to a change in stake). For the following results, we need to distinguish between the new and the unchanged block proposers. Hence, we model an increase of weight of block proposer P from ω_P to ω'_P by assuming that a new block proposer P' with weight $\omega'_P - \omega_P$ is added to the new set of block proposers. Similarly, for a decrease of weight from ω_P to ω'_P , we assume that the original set of block proposers contains two block proposers P and P' with weights $\omega_{P'}$ and $\omega_P - \omega_{P'}$, respectively. The change of weight in this case is then modeled by P' leaving the set of block proposers. This allows us to only consider a change in the set of block proposers and not additionally consider changes of weights. Note that for any active set of block proposers \mathcal{P} the weights always need to satisfy $\sum_{P \in \mathcal{P}} \omega_P = 1$.

Definition 3.9 (Unconstrained change of block proposers). We assume that there is an initial set of block proposers for round 0 defined in the genesis block B_0 . Let $d \in \mathbb{N}$ be a constant describing the delay in rounds when changes of block proposers take into effect. For every round r with $r > 0$, the set of active block proposers for round r is defined by the information in the current chain up to the last block of round $r - (d + 1)$, i.e., block $B_{(r-d-1) \cdot m + m - 1}$. Moreover, only the active block proposers at round r can propose blocks at heights $\{r \cdot m, r \cdot m + 1, \dots, r \cdot m + m - 1\}$ and send prevote and precommit messages for blocks at heights $\{r \cdot m, r \cdot m + 1, \dots, r \cdot m + m - 1\}$.

Note that for $d = 0$, the changes of block proposers take into effect immediately in the next round. Moreover, if block proposers cast prevotes and precommits implicitly via approve messages, then for a $\text{APPROVE}(k, p, B_r, P)$ message to be valid we require P to be active in the rounds associated to the blocks B_{k+1}, \dots, B_r . This way any implied $\text{PREVOTE}(A, B_r, P)$ cast according to Definition 3.6 is for a block A where P is active. As a precommit is only implied if P previously made an implicit prevote, it holds that also all implied precommits are for blocks where P is active.

We now show sufficient conditions for the safety and liveness property for the case of block proposers that change according to the mechanism described above.

Theorem 3.10. *Let $\mathcal{P}_1, \mathcal{P}_2, \dots, \mathcal{P}_s$ be the sets of block proposers that are active in any round on any branch. Then the following properties hold:*

- (a) *If $\bigcap_{i=1}^s \mathcal{P}_i$ contains at least $> (4/3 - \tau)$ honest block proposers, then two honest block proposer in $\bigcup_{i=1}^s \mathcal{P}_i$ with decision threshold at least $\tau \in (1/3, 1]$ never decide for conflicting blocks (Safety).*
- (b) *Assume that $< 1/3$ of the block proposers in \mathcal{P}_i crash and all other block proposers in \mathcal{P}_i honestly follow the general consensus protocol and LONGEST-CHAIN fork choice rule. While the block proposers \mathcal{P}_i are active, it is possible for any block proposer $P \in \mathcal{P}_i$ with decision threshold $\tau_P \in (1/3, 2/3]$ to decide on new blocks assuming the global stabilization time is reached (Liveness).*

Proof. The proof of the first part of the claim is similar to the proof of Theorem 3.2. Assume, for the sake of contradiction, that there are two conflicting blocks A and B as well as an honest block proposer $P_A \in \bigcup_{i=1}^s \mathcal{P}_i$ with decision threshold τ_A deciding for A and an honest block proposer $P_B \in \bigcup_{i=1}^s \mathcal{P}_i$ with decision threshold τ_B deciding for B . Let further \mathcal{P}_A be the set of active block proposers associated with block A and similarly \mathcal{P}_B be the set of active block proposers associated with block B . By assumption we have $\tau \leq \tau_A$ and $\tau \leq \tau_B$. Hence, there must be $\text{PRECOMMIT}(A, \cdot, \cdot)$ messages cast by $> \tau$ of the block proposers in \mathcal{P}_A and also $\text{PRECOMMIT}(B, \cdot, \cdot)$ messages cast by $> \tau$ of the block proposers in \mathcal{P}_B .

Let \mathcal{P}_H be the set of $> (4/3 - \tau)$ honest block proposers that is contained in $\bigcap_{i=1}^s \mathcal{P}_i$ by assumption. In particular, we have $\mathcal{P}_H \subseteq \mathcal{P}_A \cap \mathcal{P}_B$. There are $< 1 - (4/3 - \tau) = \tau - 1/3$ block proposers in \mathcal{P}_A that are not contained in \mathcal{P}_H and thus there are $> 1/3$ block proposers in \mathcal{P}_H that sent a $\text{PRECOMMIT}(A, \cdot, \cdot)$ message. Analogously, there are also $> 1/3$ block proposers in \mathcal{P}_H that must have sent a $\text{PRECOMMIT}(B, \cdot, \cdot)$ message.

Without loss of generality, we assume $h(A) \leq h(B)$. Let $\bar{\mathcal{P}}_H \subseteq \mathcal{P}_H$ be the subset of $> 1/3$ block proposers that send a precommit for A . By (II), every proposer $P \in \bar{\mathcal{P}}_H$ must have also cast a $\text{PREVOTE}(A, \cdot, P)$ message. Thus, by (I), no proposer in $P \in \bar{\mathcal{P}}_H$ sends a prevote for any other block at height $h(A)$. We must therefore have $h(A) < h(B)$ as otherwise B cannot obtain $> 2/3$ prevotes because $\bar{\mathcal{P}}_H$ is contained in every active set of block proposers.

By (III), every block proposer $P \in \bar{\mathcal{P}}_H$ is only allowed to send a prevote message for a block that is not a descendant of A if there is a block \bar{B} at height $h(\bar{B}) \geq h(A)$ with $\text{PREVOTE}(\bar{B}, \cdot, \cdot)$ messages by $> 2/3$ of the block proposers. As all block proposers in $\bar{\mathcal{P}}_H$ are honest, there have to be $> 2/3$ prevotes for such a block \bar{B} by block proposers not in $\bar{\mathcal{P}}_H$. This is a contradiction, as $\bar{\mathcal{P}}_H$ is a set of $> 1/3$ block proposers that is contained in any active set of block proposers. Hence, no block that is not a descendant of A can obtain $> 2/3$ prevotes and thus no honest block proposer sends a precommit for B . This means that the decision

threshold of τ_B precommit messages for block B cannot be reached contradicting that the honest block proposer P_B decided for B .

For the liveness property, the change of block proposers is not relevant and we obtain the result directly from Theorem 3.4. \square

The above theorem shows that the safety guarantee is only slightly weaker if only a small fraction of the block proposers change. However, several changes of a small fraction of block proposers over time could amount to almost all block proposers changing. The following result shows that as long as the block proposers finalize blocks in between these changes of block proposers, we can improve the safety guarantee above.

Theorem 3.11. *Let $\alpha \in (0, 1/3)$ and $\tau \in (1/3 + 2\alpha, 1]$. Let B, B' be two blocks in one branch such that B' is the descendant of B with minimal height such that the chain up to B' contains $> \tau$ precommits for a descendant of B . We assume that between all such pairs of blocks B and B' in the block tree $< \alpha$ honest proposers in the active set of block proposers change. If there are $> 4/3 - \tau + 2\alpha$ honest block proposers in any active set of block proposers, then two block proposers with decision threshold at least τ never decide for conflicting blocks.*

Proof. As the set of block proposers is changing over time, there can now be blocks at the same height which assume a different set of block proposers. For instance, one chain may contain the information regarding a change of block proposers, whereas another chain does not. Thus, we now associate a unique active set of block proposers to every block of the block tree, which is determined using the rule given in Definition 3.9.

Let us assume, for the sake of contradiction, that there are two conflicting blocks B_1 and B_2 such that an honest block proposer P_1 with decision threshold τ_1 decides for B_1 and another honest block proposer P_2 with decision threshold τ_2 decides for B_2 . Let A_0 be the block of largest height that is a common ancestor of B_1 and B_2 . Moreover, let A_1 be the first descendant of A_0 on the branch containing B_1 that has τ precommits contained in that branch. Similarly, let A_2 be the first descendant of A_0 on the branch containing B_2 that has τ precommits contained in that branch. The setting is shown in Figure 2. As $\tau_1 \geq \tau$, there must be at least τ precommits for B_1 contained in the branch containing B_1 and therefore we must have $A_1 = B_1$ or A_1 is an ancestor of B_1 . The same holds for A_2 and B_2 . Without loss of generality let $h(A_1) \leq h(A_2)$.

For $i \in \{0, 1, 2\}$, let \mathcal{P}_i be the set of block proposers associated with A_i . By assumption, $< \alpha$ honest block proposers change before a block on a branch receives $> \tau$ precommits and there are $> 4/3 - \tau + 2\alpha$ honest block proposers in any active set of block proposers. Thus, $\mathcal{P}_0 \cap \mathcal{P}_i$ contains a subset of $> 4/3 - \tau + \alpha$ honest block proposers. Hence, $\mathcal{P}_1 \cap \mathcal{P}_2$ must contain a subset \mathcal{P}_H of honest block proposers of weight $> 4/3 - \tau$ that is also contained in the active set of proposers associated to any block on the path from A_0 to A_1 or the path from A_0 to A_2 . By assumption, there are $\text{PRECOMMIT}(A_1, \cdot, \cdot)$ by $> \tau$ of the block proposers in the chain containing B_1 and \mathcal{P}_1 contains $< \tau - 1/3$ proposers not contained in \mathcal{P}_H . Therefore, there must be a subset $\mathcal{P}'_H \subseteq \mathcal{P}_H$ of $> 1/3$ honest block proposers that cast a precommit for A_1 . This also implies that we cannot have $h(A_1) = h(A_2)$ as there can only be $\leq 2/3$ prevotes for A_2 and hence no honest block proposer $P \in \mathcal{P}_2$ would cast a $\text{PRECOMMIT}(A_2, \cdot, P)$ by (II). Thus, the threshold of τ precommits for block A_2 cannot be reached in this case and we must have $h(A_1) < h(A_2)$.

Definition 4.1 (LISK-BFT). Let $C := B_0, B_1, \dots, B_{l-1}$ be the current chain of delegate P and $h_0 \in \{0, 1, \dots, l\}$ be the height of the first block of the round since when P has been continuously active delegate.

1. When P proposes block B_l as a child of B_{l-1} , it adds the following information to the block header:

h_{previous}	The largest height of a block that P previously proposed (on any branch) and 0 if P has not proposed any block.
h_{prevoted}	The height of the block of largest height with at least 68 prevotes in the current chain B_0, B_1, \dots, B_{l-1} .

In general, for a block B we use the notation $h_{\text{previous}}(B)$ and $h_{\text{prevoted}}(B)$ to refer to the values above.

2. If $h_{\text{previous}}(B_l) < h(B_l)$ holds, then the information in the block header of B_l implies prevotes and precommits for blocks in the following order:
 - (a) Let $k := \max\{h_{\text{previous}}(B_l), h_0 - 1, l - 303\}$. Then the block header implies a $\text{PREVOTE}(A, B_l, P)$ for every block $A \in \{B_{k+1}, B_{k+2}, \dots, B_l\}$.
 - (b) Considering the implied prevotes and precommits included in the chain C (via the additional information in the block headers), let

$$\begin{aligned}
j_1 &:= \max(\{0 \leq s \leq l \mid \exists \text{PRECOMMIT}(B_s, \cdot, P) \text{ in chain } C\} \cup \{-1\}) \\
j_2 &:= \max(\{0 \leq s \leq h_{\text{previous}}(B_l) \mid \nexists \text{PREVOTE}(B_s, \cdot, P) \text{ in chain } C\} \cup \{-1\}) \\
j &:= \max\{j_1, j_2, h_0 - 1, l - 303\} + 1.
\end{aligned}$$

Then the block header implies a $\text{PRECOMMIT}(A, B_l, P)$ for every block A in the set $\{B_j, \dots, B_l\}$ that has prevotes by at least 68 delegates included in the chain C .

3. A block B and all ancestors of B are finalized if there are precommits for B by at least 68 delegates included in the chain C .
4. The active delegates of round r are determined taking all votes included in the blockchain up to the end of round $r - 3$ into account (without requiring finality).
5. Delegates follow the **LONGEST-CHAIN** rule, where the block of largest height with at least 68 prevotes in a chain A_0, A_1, \dots, A_s is computed taking only the prevotes implied by blocks A_0, A_1, \dots, A_{s-1} , and not those implied by A_s , into account.

The LISK-BFT protocol is an application of the general consensus framework from the last section, where delegates only cast prevotes and precommits via the additional information in the block headers. The values h_{previous} and h_{prevoted} in the block header of block B_l correspond to the delegate P first proposing block B_l and afterwards sending the message $\text{APPROVE}(h_{\text{previous}}, h_{\text{prevoted}}, B_l, P)$. However, the transformation of the header information to prevote and precommit messages above contains two modifications compared to the transformation for approve messages in Definition 3.6. First of all, we have $k = \max\{h_{\text{previous}}, h_0 - 1, l - 303\}$ instead of $k = h_{\text{previous}}$. The reason for enforcing $k \geq h_0 - 1$ is to ensure that the implied prevotes are only for blocks at heights where delegate P was

active. We further enforce $k \geq l - 303$ for performance reasons so that it is sufficient to consider the last 303 blocks when updating the number of prevotes for blocks. Note that the parameter 303 is chosen due to the fact that a block can be finalized after 302 additional blocks are added on top (see the liveness proof of Theorem 4.3), but depending on the ordering of delegates in a round, 201 additional blocks are not always sufficient. Secondly, we have $j = \max \{j_1, j_2, h_0 - 1, l - 303\} + 1$ instead of $j := \max \{j_1, j_2\} + 1$. Again, this ensures that all implied precommits are for blocks where P was active and also for performance reasons all precommits are only for a subset of the last 303 blocks. Overall, it is important to note that the prevotes and precommits implied by the transformation above are a subset of the prevotes and precommits implied according to Definition 3.6 when instead sending the message $\text{APPROVE}(h_{\text{previous}}, h_{\text{prevoted}}, B_l, P)$.

A subtlety of the transformation 2 (b) above is that we consider only the prevotes implied by all blocks up to B_{l-1} and not the prevotes implied by 2 (a). This is analogous to the transformation for approve messages in Definition 3.6.

We establish some basic properties of the LISK-BFT protocol in the following lemma.

Lemma 4.2. *Let B_1 and B_2 be two distinct blocks proposed by an honest delegate P according to the LISK-BFT protocol. Then the following properties hold:*

(a) *The LONGEST-CHAIN rule implies that a branch with tip B is chosen over a branch with tip A , if the following conditions are satisfied:*

$$h_{\text{prevoted}}(B) > h_{\text{prevoted}}(A) \quad \text{or} \quad (h_{\text{prevoted}}(B) = h_{\text{prevoted}}(A) \text{ and } h(B) > h(A)).$$

(b) *If B_1 is proposed before B_2 , then the following inequalities hold:*

$$h_{\text{previous}}(B_1) \leq h_{\text{previous}}(B_2), \quad h_{\text{prevoted}}(B_1) \leq h_{\text{prevoted}}(B_2), \quad h(B_1) \leq h_{\text{previous}}(B_2).$$

(c) *If B_1 is proposed before B_2 and $h_{\text{prevoted}}(B_1) = h_{\text{prevoted}}(B_2)$ holds, then we must have $h(B_1) < h(B_2)$.*

(d) *Block B_1 is proposed before B_2 if and only if*

$$(h_{\text{previous}}(B_1), h_{\text{prevoted}}(B_1), h(B_1)) <_{\text{lex}} (h_{\text{previous}}(B_2), h_{\text{prevoted}}(B_2), h(B_2)), \quad (1)$$

where $<_{\text{lex}}$ is the lexicographical ordering.

(e) *If any two blocks by delegate P satisfy the inequalities in (b), then the implied prevotes and precommits according to the LISK-BFT protocol satisfy the conditions of the general consensus framework in Definition 3.1.*

Proof. (a) According to the LONGEST-CHAIN rule, the first deciding factor is the largest height of a block with at least 68 prevotes contained in some branch of the block tree. For a chain with tip A , the largest height of a block with at least 68 prevotes is given by $h_{\text{prevoted}}(A)$ because the prevotes implied by the block header of A are not taken into account. If there are multiple chains that contain a block with at least 68 prevotes of the same height, then the longer chain containing these prevotes has priority according to the LONGEST-CHAIN rule. This immediately yields the condition in the claim.

- (b) As B_2 is proposed after B_1 and the largest height of a block previously proposed is non-decreasing, we must have $h_{\text{previous}}(B_1) \leq h_{\text{previous}}(B_2)$. As delegate P follows the LONGEST-CHAIN rule, the tips of the canonical chain of P satisfy that $h_{\text{prevoted}}(\cdot)$ is non-decreasing by claim (a). Thus, we must have $h_{\text{prevoted}}(B_1) \leq h_{\text{prevoted}}(B_2)$. Moreover, when proposing B_2 , the largest height of a block previously proposed must be at least $h(B_1)$. This implies $h(B_1) \leq h_{\text{previous}}(B_2)$.
- (c) By claim (a), every time delegate P switches to a different chain, either $h_{\text{prevoted}}(\cdot)$ is strictly increasing or it remains unchanged and the height of the tip strictly increases. The same holds every time a new child is added to the tip of the chain of delegate P (either proposed by P or another delegate). Thus, if $h_{\text{prevoted}}(B_1) = h_{\text{prevoted}}(B_2)$ holds, then we must have $h(B_1) < h(B_2)$.
- (d) Assume B_1 is proposed before B_2 . By claim (b), we must have $h_{\text{previous}}(B_1) \leq h_{\text{previous}}(B_2)$ and $h_{\text{prevoted}}(B_1) \leq h_{\text{prevoted}}(B_2)$. Moreover, by (c), we have $h(B_1) < h(B_2)$ if $h_{\text{prevoted}}(B_1) = h_{\text{prevoted}}(B_2)$. Thus, Inequality (1) must hold. The other direction follows by contraposition.
- (e) We need to show that the implied prevotes and precommits according to the transformation in Definition 4.1 satisfy the protocol rules (I)–(III) of the general consensus framework. The proof works analogous to the proof of Lemma 3.7.

Let T and T' be two distinct blocks proposed by a delegate P , where T' is proposed after T . By claim (b), we have $h(T) \leq h_{\text{previous}}(T')$. Any $\text{PREVOTE}(A, T, P)$ implied by T satisfies $h(A) \leq h(T)$ and any $\text{PREVOTE}(A', T', P)$ implied by T' satisfies $h(A') > h_{\text{previous}}(T') \geq h(T)$. This means that all implied prevotes are for distinct heights, i.e., (I) is satisfied.

Next, consider some $\text{PRECOMMIT}(A, B_l, P)$ implied by a block B_l , where we use the notation from Definition 4.1. We then have $h(A) > j_2$ and hence P must have cast a prevote for A (implied by 2 (a) or a previous block by P in the current chain). By the definition of the transformation there are at least 68 prevotes for A in the chain up to B_{l-1} . Hence, (II) is satisfied for all precommit messages.

Finally, for showing (III), consider a $\text{PRECOMMIT}(A, T, P)$ and a $\text{PREVOTE}(A', T', P)$ with $h(A) < h(A')$ implied by two blocks T and T' . If A' is a descendant of A , then (III) is satisfied. Otherwise, we must show that there exists a block \bar{B} at height $h(\bar{B}) \geq h(A)$ with $\text{PREVOTE}(\bar{B}, \cdot, \cdot)$ by at least 68 of the delegates contained in the blockchain up to block T' .

We first show that T' must be proposed after T . Assume, for the sake of contradiction, that T' is proposed before T . By claim (b), we then have $h(T') \leq h_{\text{previous}}(T) < h(T)$ and, in particular, $h(A') \leq h(T') < h(T)$. By our assumption, A' is not a descendant of A so A' cannot be on the branch containing A and T . But then the branch containing A and T does not contain any prevote for a block at height $h(A')$ because (I) is satisfied. This means that any precommit implied by T must be for blocks at height at least $h(A') + 1$, which contradicts $h(A) < h(A')$ and that $\text{PRECOMMIT}(A, T, P)$ is implied by T . Hence, T' must be proposed after T .

By claim (b), we then obtain $h_{\text{prevoted}}(T) \leq h_{\text{prevoted}}(T')$. We further have $h(A) \leq h_{\text{prevoted}}(T)$ because $h_{\text{prevoted}}(T)$ is the largest height of a block with prevotes by 68 of

the delegates included in the chain up to T . Let \bar{B} be the block at height $h_{\text{prevoted}}(T')$ that is an ancestor of T' . We have $h(A) \leq h_{\text{prevoted}}(T) \leq h_{\text{prevoted}}(T') = h(\bar{B})$ and there are $\text{PREVOTE}(\bar{B}, \cdot, \cdot)$ by at least 68 delegates contained in the blockchain up to T' . Thus, (III) is also satisfied. \square

Using the basic properties above, we now show the desired safety, liveness and accountability properties of the LISK-BFT protocol. Note that for showing the liveness property we assume that at most 33 delegates are offline, i.e., not forging any blocks, and we do not consider Byzantine delegates. As delegates cast prevotes and precommits together with the block proposal in the LISK-BFT protocol, Byzantine delegates could intentionally create competing branches in the block tree so that the prevotes and precommits of some honest delegates are not considered as their block is not eventually included in the canonical chain. Such an attack would only be successful if a substantial number of Byzantine delegates coordinate the creation of competing branches and at regular times multiple Byzantine delegates can consecutive propose blocks so that the competing chain becomes longer than the chain previously forged by the honest delegates. We believe that such an attack is rather unlikely as it requires a lot of coordination and a favorable delegate ordering for the attackers. Further, it only effects the liveness property, but not the safety property.

Theorem 4.3. *The LISK-BFT protocol has the following properties:*

- (a) *Let $\mathcal{P}_1, \mathcal{P}_2, \dots, \mathcal{P}_s$ be distinct sets of active delegates over time. If $\bigcap_{i=1}^s \mathcal{P}_i$ contains at least 68 honest delegates, then two honest delegates in $\bigcup_{i=1}^s \mathcal{P}_i$ never finalize conflicting blocks.*
- (b) *Assume that at most $m \in \{1, \dots, 16\}$ honest delegates change without a block obtaining 68 precommits by the active delegates and assume at any time there are $68 + 2m$ honest delegates contained in the active set of delegates. Then two honest delegates never finalize conflicting blocks.*
- (c) *If at most 33 delegates are offline and all other delegates honestly follow the LISK-BFT protocol, then for every $l \in \mathbb{N}$ an honest delegate eventually finalizes a block at height l (assuming the global stabilization time GST is reached and there are regular intervals of 303 consecutive blocks with an unchanged subset of 68 active honest delegates).*
- (d) *If a Byzantine delegate forges blocks such that the implied prevotes and precommits violate the general consensus framework, then this protocol violation can be detected and the Byzantine delegate can be identified.*

Proof. By Lemma 4.2, the implied prevotes and precommits in the LISK-BFT protocol satisfy the LISK-BFT protocol rules (I)–(III). Applying Theorem 3.10 for $\tau = 2/3$ yields the first claim. For the second claim, we apply Theorem 3.11 with $\tau = 2/3$ and $\alpha = m/101$.

For the liveness property in the third claim, consider an arbitrary state of the block tree and an arbitrary set of blocks proposed according to the LISK-BFT protocol. Moreover, we assume that we have reached the global stabilization time GST so that all message arrive reliably within time Δ . Let further $l \in \mathbb{N}$ and h_{\max} be the largest height that any honest delegate proposed a block for. We show that an honest delegate eventually finalizes a block at height l .

After time GST, all honest delegates are aware of all competing chains. There could be multiple competing chains for which $h_{\text{previous}}(\cdot)$ and $h(\cdot)$ of the tip of the chain is the

same, but one block proposed by an honest delegate always breaks these ties. Afterwards, in every proposal slot, there is one unique block A such that for every other block A' either $h_{\text{prevoted}}(A) > h_{\text{prevoted}}(A')$ or $h_{\text{prevoted}}(A) = h_{\text{prevoted}}(A')$ and $h(A) > h(A')$ holds. This means A is the tip of the canonical chain of every honest delegate.

This canonical chain of all honest delegates will continue growing until it contains a block B at height $h(B) > \max\{l, h_{\max}\}$. We assume that there is a subset \mathcal{P}_H of at least 68 honest delegates that is also in the sets of active delegates associated with the subsequent 302 blocks. We show that after first 67 distinct delegates in \mathcal{P}_H and then another 68 distinct delegates in \mathcal{P}_H add a block as descendant of B , block B is finalized. As all delegates add blocks to the same chain and any round contains blocks by at least 68 distinct delegates (at most 33 are offline), this happens within the next 302 blocks added as descendant to B .

Any block B' by an honest delegate $P \in \mathcal{P}_H$ that build on B satisfies $h_{\text{previous}}(B') < h(B)$ if P did not propose B or another descendant of B already. By the transformation in Definition 4.1, B' implies a prevote for B as P was active at height $h(B)$ and $h(B') - h(B) \leq 302$. Hence, once there are 68 distinct delegates in \mathcal{P}_H that either proposed B or added a block to the chain extending B , block B has received 68 prevotes. Any subsequent block B' by an honest delegate $P \in \mathcal{P}_H$ implies a precommit by P for B , because according to the transformation in Definition 4.1 we have

- $j_2 < h(B)$, as all honest proposers added blocks to the same chain extending B ,
- $j_1 < h(B)$, because otherwise P already made a precommit for B ,
- $h_0 \leq h(B)$, since all delegates in \mathcal{P}_H are continuously active,
- $h(B') - h(B) \leq 302$, as argued above.

Hence after another set of 68 distinct blocks in \mathcal{P}_H are added to the chain, there are 68 precommits for B . This means that B and all ancestors of B are finalized by any honest delegate. In particular, any honest delegate finalizes a block at height l as $h(B) > l$.

For the last claim, note that Lemma 4.2 (b) states the conditions that must hold if a delegate follows the LISK-BFT protocol. By Lemma 4.2 (e), these are also sufficient for the implied prevotes and precommits to satisfy (I)–(III) of the general consensus framework. In order to determine whether the implied prevotes and precommits of blocks forged by a delegate P obey the protocol rules (I)–(III), it is therefore sufficient to consider every pair of blocks B_1 and B_2 proposed by P , determine which one was proposed first according to Lemma 4.2 (d), and then check if the inequalities given in Lemma 4.2 (b) hold. \square

5 Conclusion

We introduced a general consensus framework for blockchains which allows to prove safety and liveness depending on the number of Byzantine block proposers. As a concrete application of the consensus framework we defined the LISK-BFT protocol, which allows to obtain strong guarantees with respect to safety and liveness while requiring no additional messages for the consensus as the necessary information is efficiently encoded in the block headers.

Another interesting possible application of the general consensus framework could be to combine it together with a suitable aggregate signature scheme. For instance, block proposers could send a $\text{APPROVE}(h(B_l) - 1, \cdot, B_l, P)$ message for the block they believe to be the correct block at height l . Using an aggregate signature scheme, these messages could be efficiently

aggregated in the network and only added to any child block of B_l by the next proposer. Applying the properties of the general consensus framework analogous to the case of the LISK-BFT protocol, it is possible to show that a block can be finalized already after two additional blocks are added as descendants.

References

- [1] Ethan Buchman, Jae Kwon, and Zarko Milosevic. “The latest gossip on BFT consensus”. In: *arXiv e-prints* (2018). arXiv: 1807.04938.
- [2] Vitalik Buterin. *Immediate message-driven GHOST as FFG fork choice rule*. URL: <https://ethresear.ch/t/immediate-message-driven-ghost-as-ffg-fork-choice-rule/2561> (visited on 06/09/2018).
- [3] Vitalik Buterin. *In favor of forkfulness*. URL: <https://ethresear.ch/t/in-favor-of-forkfulness/1225> (visited on 06/09/2018).
- [4] Vitalik Buterin and Virgil Griffith. “Casper the Friendly Finality Gadget”. In: *arXiv e-prints* (2017). arXiv: 1710.09437.
- [5] Christian Cachin, Klaus Kursawe, and Victor Shoup. “Random Oracles in Constantinople: Practical Asynchronous Byzantine Agreement Using Cryptography”. In: *Journal of Cryptology* 18.3 (2005), pp. 219–246. DOI: 10.1007/s00145-005-0318-0.
- [6] Miguel Castro and Barbara Liskov. “Practical Byzantine Fault Tolerance and Proactive Recovery”. In: *ACM Trans. Comput. Syst.* 20.4 (2002), pp. 398–461. DOI: 10.1145/571637.571640.
- [7] Cynthia Dwork, Nancy A. Lynch, and Larry J. Stockmeyer. “Consensus in the presence of partial synchrony”. In: *Journal of the ACM* 35.2 (1988), pp. 288–323. DOI: 10.1145/42282.42283.
- [8] Michael J. Fischer, Nancy A. Lynch, and Michael Merritt. “Easy Impossibility Proofs for Distributed Consensus Problems”. In: *Distributed Computing* 1.1 (1986), pp. 26–39. DOI: 10.1007/BF01843568.
- [9] Michael J. Fischer, Nancy A. Lynch, and Mike Paterson. “Impossibility of Distributed Consensus with One Faulty Process”. In: *J. ACM* 32.2 (1985), pp. 374–382. DOI: 10.1145/3149.214121.
- [10] Valerie King and Jared Saia. “Faster Agreement via a Spectral Method for Detecting Malicious Behavior”. In: *Proceedings 25th Annual ACM-SIAM Symposium on Discrete Algorithms (SODA)*. 2014, pp. 785–800. DOI: 10.1137/1.9781611973402.58.
- [11] Ramakrishna Kotla et al. “Zyzyva: Speculative Byzantine fault tolerance”. In: *ACM Trans. Comput. Syst.* 27.4 (2009), 7:1–7:39. DOI: 10.1145/1658357.1658358.
- [12] Leslie Lamport. “The Part-Time Parliament”. In: *ACM Trans. Comput. Syst.* 16.2 (1998), pp. 133–169. DOI: 10.1145/279227.279229.
- [13] Satoshi Nakamoto. *Bitcoin: A Peer-to-Peer Electronic Cash System*. 2008. URL: <http://www.bitcoin.org/bitcoin.pdf> (visited on 06/09/2018).

- [14] Olivier Rütli, Zarko Milosevic, and André Schiper. “Generic construction of consensus algorithms for benign and Byzantine faults”. In: *Proc. International Conference on Dependable Systems and Networks (DSN)*. 2010, pp. 343–352. DOI: 10.1109/DSN.2010.5544299.