

Imaging microscopic electronic contrasts at the interface of single-layer WS₂ with oxide and boron nitride substrates

Søren Ulstrup,^{1,*} Roland J. Koch,² Daniel Schwarz,² Kathleen M. McCreary,³ Berend T. Jonker,³ Simranjeet Singh,⁴ Aaron Bostwick,² Eli Rotenberg,² Chris Jozwiak,² and Jyoti Katoch^{4,†}

¹*Department of Physics and Astronomy, Aarhus University, 8000 Aarhus C, Denmark*

²*Advanced Light Source, E. O. Lawrence Berkeley National Laboratory, Berkeley, California 94720, USA*

³*Naval Research Laboratory, Washington, D.C. 20375, USA*

⁴*Department of Physics, Carnegie Mellon University, Pittsburgh, Pennsylvania 15213, USA*

The electronic properties of devices based on two-dimensional materials are significantly influenced by interactions with substrate and electrode materials. Here, we use photoemission electron microscopy to investigate the real- and momentum-space electronic structures of electrically contacted single-layer WS₂ stacked on hBN, SiO₂ and TiO₂ substrates. Using work function and X-ray absorption imaging we single-out clean microscopic regions of each interface type and collect the valence band dispersion. We infer the alignments of the electronic band gaps and electron affinities from the measured valence band offsets of WS₂ and the three substrate materials using a simple electron affinity rule and discuss the implications for vertical band structure engineering using mixed three- and two-dimensional materials.

Semiconducting transition metal dichalcogenides (TMDs) at the single-layer (SL) limit offer entirely new possibilities for fabricating field-effect transistors with atomically thin gating materials and sophisticated contact electrode geometries leading to nanoscale engineered unipolar and ambipolar charge carrier transport [1–6]. These properties are determined by the electronic band alignments at the vertically stacked interfaces of the active device components, which can be tailored using junctions of TMDs in combination with other TMDs [7], TMDs and oxides [8, 9] as well as mixed two-dimensional (2D) and three-dimensional (3D) materials [10]. Understanding how key band alignment parameters such as the valence band (VB) offsets, quasiparticle band gap energies E_g , and electron affinities χ , depend on the interface type and quality as well as environmental screening remains an important issue for band structure engineering utilizing 2D materials [11].

The interplay of these parameters on the electronic properties of SL TMD devices is ideally investigated using spectromicroscopic probes of the electronic structure [12]. Photoemission electron microscopy (PEEM) is a powerful method in this regard because it offers fast switching between real space and k -space imaging modes with work function, core level absorption and VB contrasts [9, 13, 14]. The use of k -resolved PEEM for performing microscale angle-resolved photoemission spectroscopy (microARPES) has been an essential tool for observing band structures of SL and few-layer MoS₂ [15, 16] and WSe₂ [17] exfoliated on SiO₂ substrates.

Here, we use the SPECS PEEM P90 microscope installed at the Microscopic And Electronic STRucture Observatory (MAESTRO) at the Advanced Light Source to investigate the electronic properties of vertical stacks

based on SL WS₂ transferred on oxide and hexagonal boron nitride (hBN) substrates. The thickness of WS₂ is checked before and after transfer using photoluminescence and Raman spectroscopy as shown in our earlier works [9, 18]. The influence of the dielectric environment on the electronic properties of SL WS₂ is studied using insulating 300 nm SiO₂ on Si (SiO₂/Si) with relative permittivity $\epsilon_{\text{SiO}_2} = 3.9$ and 0.5 wt % Nb-doped rutile TiO₂(100) (Shinkosha Co., Ltd) with $\epsilon_{\text{TiO}_2} = 113$ as supporting substrate. We assemble WS₂/hBN heterostructures ($\epsilon_{\text{hBN}} \approx 4$) on both oxides utilizing a similar transfer technique as previously reported [9, 19] and as described further in the Supplementary Material. On SiO₂ we deposit an Au electrode that is contacted to both SL WS₂ and hBN on the side (see optical microscope image in Fig. 1(a)) which is essential to avoid charging during photoemission measurements. The Nb doping of TiO₂ is sufficient to prevent charging. By shorting the WS₂ flake on hBN to the TiO₂ we avoid using a metal electrode in this system.

The rationale of using SiO₂, hBN and TiO₂ as substrates for SL WS₂ is three-fold: (i) These materials are commonly used in devices where they are known to exhibit strong variations in interfacial quality with other 2D materials [9, 20, 21], (ii) the dielectric properties vary strongly across the interfaces, potentially affecting the electronic bandstructure of the adjacent SL WS₂ [22, 23], and (iii) the quasiparticle band gaps and electron affinities are very different and thus give rise to substantially different band alignments. Here, we address these key points by first presenting PEEM measurements of electronic contrasts to identify the three types of interfaces and investigate their quality from a photoemission perspective. We then discuss k -resolved electronic structure measurements and use these to infer the band alignments of the systems.

The photoemission intensity variations during *in situ* annealing of the SiO₂ supported sample to 380 °C are studied in PEEM using a Hg excitation source as shown

* address correspondence to ulstrup@phys.au.dk

† address correspondence to jkatoch@andrew.cmu.edu

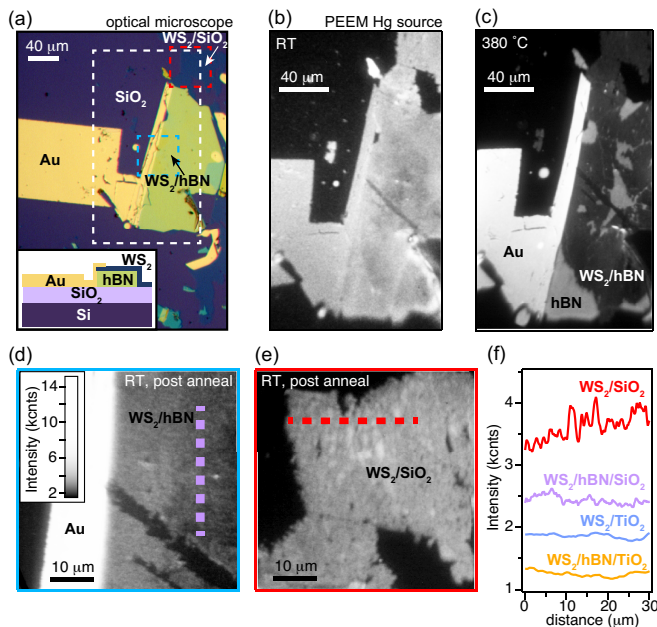

FIG. 1. Work function contrasts: (a) Optical microscope image of a SiO_2 supported sample assembled according to the diagram in the insert. (b)-(c) PEEM images at (b) room temperature before annealing and (c) 380°C measured within the dashed white box in (a). (d)-(e) Post annealing PEEM images at room temperature focusing on (d) a WS_2/hBN region near the Au contact (blue dashed square in (a)) and (e) a WS_2/SiO_2 region adjacent to the hBN flake (red dashed square in (a)). (f) Line profiles obtained along the dashed purple and red lines in (d) and (e) and the dashed blue and orange lines in Fig. 2(b). The color scale in (d) applies to all PEEM images.

in Figs. 1(b)-(c). The average contrast levels for Au, SL WS_2 and hBN areas are similar before annealing (panel (b)) making it difficult to distinguish the materials. During annealing the intensity of the Au electrode increases (panel (c)). This behavior indicates a lowering of the Au work function giving rise to higher secondary electron emission and therefore higher intensity. The reduction of secondary electron emission from WS_2 on hBN during annealing indicates an increase in work function, possibly due to a change in doping caused by the desorption of water. The intensity levels from patches of WS_2 on SiO_2 and on hBN adjust slightly after cooling down. Most importantly, we observe that there is no sign of Au diffusion on the surface at these annealing conditions in ultra-high vacuum (UHV) at 380°C .

The same piece of transferred SL WS_2 covers the SiO_2 substrate in the part marked by a dashed red box in Fig. 1(a). We can therefore compare the contrast levels on both hBN and SiO_2 as shown in Figs. 1(d)-(f). On WS_2/hBN in panel (d) the intensity exhibits only minor fluctuations with respect to the average, as demonstrated by the line profile in Fig. 1(f). Much stronger contrasts

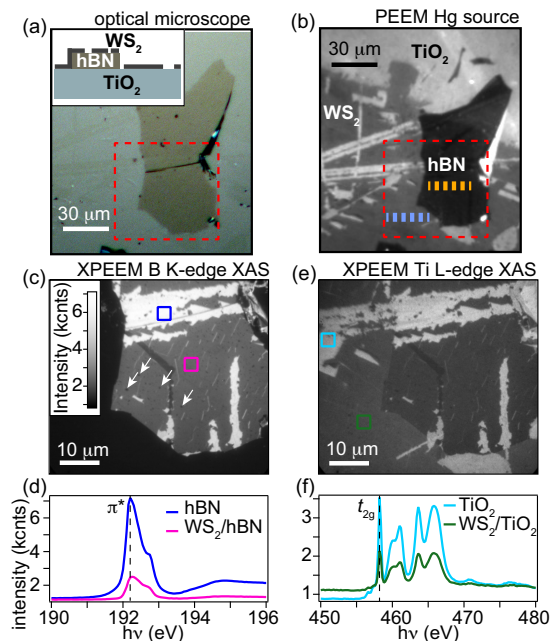

FIG. 2. X-ray absorption imaging: (a) Optical microscope image of a TiO_2 supported sample with the stacking illustrated in the insert. (b) Hg PEEM image of the same region as shown in (a). (c) Secondary electron contrast from the π^* -resonance of the boron K-edge. White arrows point to examples of trapped bubbles in the van der Waals interface. (d) Area-selective XAS spectra of the boron K-edge collected from bare hBN (blue box in (c)) and WS_2 covered hBN (magenta box in (c)). (e)-(f) Corresponding (e) image and (f) XAS spectra for the t_{2g} resonance of the Ti L-edge of bare TiO_2 (cyan box in (e)) and WS_2 on TiO_2 (green box in (e)). The color scale bar in (c) also applies to (e).

are observed on WS_2/SiO_2 in panel (e), which are quantified in panel (f) as intensity fluctuations within a scale of $2\ \mu\text{m}$ and a slow intensity increase over the full $30\ \mu\text{m}$ range of the profile. These features are indicative of both long range and short range potential energy variations on the SiO_2 , which are likely caused by remaining charge impurities that inevitably form in such WS_2/SiO_2 interfaces [24]. Removing such strong potential energy fluctuations is essential for electronic structure measurements as this greatly reduces energy broadening of the measured bands. This may be achieved using the conductive TiO_2 interface seen in the optical microscope image in Fig. 2(a) and the Hg PEEM image in Fig. 2(b) obtained after annealing to 380°C . Parts of a transferred WS_2 triangle straddle both the TiO_2 and the hBN flake. Representative line profiles from these two regions are compared with the SiO_2 sample in Fig. 1(f) and exhibit much less fluctuations as expected for the conductive and thus more strongly screening TiO_2 interface [9].

X-ray PEEM (XPEEM) is applied for X-ray absorption spectroscopy (XAS) and imaging of the absorption peaks of the boron K-edge and titanium L-edge in Figs.

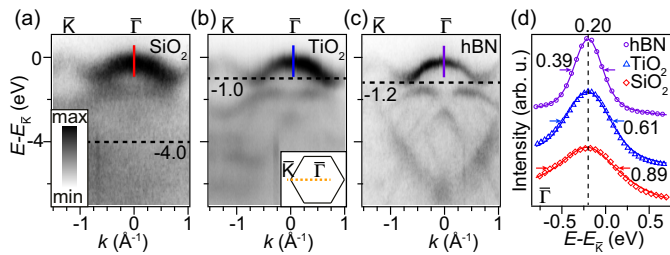

FIG. 3. Electronic structures measured by k -resolved PEEM: (a)-(c) Photoemission spectra of SL WS₂ on (a) SiO₂, (b) TiO₂ and (c) hBN measured along the \bar{K} - $\bar{\Gamma}$ direction marked by an orange dashed line on the BZ in the insert of (b). The dashed horizontal lines in (a)-(c) provide the VB offsets for the substrates (error bars are ± 0.1 eV). (d) EDCs (markers) with fits (curves) extracted at $\bar{\Gamma}$ as indicated by the correspondingly colored vertical bars in (a)-(c). The fitted peak position is marked with a vertical dashed line, and FWHM values are stated with arrows. All energy values are in units of eV.

2(c)-(f). The image in Fig. 2(c) was obtained using secondary electron contrast of the boron π^* resonance such that bare hBN areas exhibit a high intensity [14]. This reveals cracks and tears in the transferred WS₂ as well as dark sub-micron spots (see white arrows for a few examples in panel (c)) which are trapped bubbles that form in transferred van der Waals heterostructures [25]. The spatially resolved XAS spectra in Fig. 2(d) are obtained by integrating the intensity within the blue and magenta boxes on bare and WS₂ covered hBN shown in panel (c). The expected π^* resonance is observed in addition to a shoulder which appears after SL WS₂ transfer [14]. Using secondary electron contrast from the t_{2g} resonance on the TiO₂ L-edge we are able to distinguish bare and WS₂ covered TiO₂ in Fig. 2(e). The area-selective XAS spectra over the entire edge shown in Fig. 2(f) resemble typical pristine TiO₂ spectra, indicating the cleanliness of the interface [9].

Having established the characteristic real space electronic contrasts, we collect distinct microARPES spectra with k -resolved PEEM from clean areas of the three vertical interfaces WS₂/SiO₂ (Fig. 3(a)), WS₂/TiO₂ (Fig. 3(b)) and WS₂/hBN (Fig. 3(c)). The WS₂/hBN dispersion in Fig. 3(c) is measured on the SiO₂ supported sample, but we get similar spectra from WS₂/hBN on TiO₂ [19]. The data were obtained along the \bar{K} - $\bar{\Gamma}$ high symmetry direction of the SL WS₂ Brillouin zone (BZ), permitting us to identify the global valence band maximum (VBM) at \bar{K} and the local maximum at $\bar{\Gamma}$ as expected for SL WS₂ [26]. Note that the energy scale is referenced to the energy of the VBM at \bar{K} . Energy distribution curve (EDC) fits to Voigt line shapes on a linear background at $\bar{\Gamma}$ provide an offset of 0.20(4) eV from the peak position to the VBM at \bar{K} for all interfaces as seen in Fig. 3(d). The full width at half maximum (FWHM) values for the fitted Voigt peaks demonstrate sharpest SL WS₂ bands

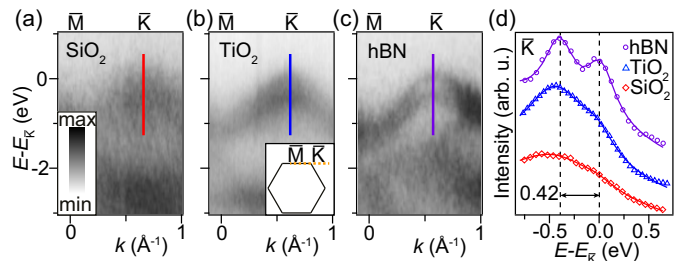

FIG. 4. Substrate influence on VBM at \bar{K} of SL WS₂: (a)-(c) Photoemission spectra on (a) SiO₂, (b) TiO₂ and (c) hBN for the \bar{M} - \bar{K} cut marked by an orange dashed line in (b). (d) EDCs (markers) with fits (curves) extracted at \bar{K} as shown by correspondingly colored vertical bars in (a)-(c). The vertical dashed lines and double-headed arrow mark the given energy separation between the two peaks in units of eV.

on hBN with a FWHM value of 0.39(1) eV (see arrows in Fig. 3(d)). Extensive broadening is observed across the oxides with the FWHM value more than doubled on SiO₂.

Measurements along \bar{M} - \bar{K} further reveal the spin-orbit split VBs at \bar{K} as seen in Figs. 4(a)-(c). EDC fits lead to a value for the spin-orbit splitting of 0.42(6) eV for WS₂/hBN as demonstrated in Fig. 4(d), which is in agreement with other studies [9, 19]. The linewidth broadening masks the spin-orbit splitting to such an extent that the EDC fits for SiO₂ and TiO₂ in Fig. 3(g) had to be performed with the peak separations constrained to the values obtained on hBN. The broad VB states of WS₂/SiO₂ are consistent with similar measurements on MoS₂/SiO₂ [15, 16, 27], which may be explained by charge impurities rigidly shifting and broadening the bands as hinted by the work function contrast in Fig. 1(e). Such effects are also present in TiO₂, although less dramatic [9]. The surface roughness in the oxides is expected to be substantially higher than in hBN [28], which causes additional momentum broadening.

We determine the VBM offsets for the substrates (marked by dashed horizontal lines in Figs. 3(a)-(c)) as described in the Supplementary Material and apply the electron affinity rule as the simplest method of constructing the band alignment diagrams of our mixed 2D-3D heterojunctions with respect to the vacuum level E_{vac} in Fig. 5 [12]. In all cases we assume the measured quasiparticle band gap of SL WS₂ on SiO₂ given by $E_g^{WS_2} = 2.4$ eV [29]. Substrate values for E_g and χ are given in Fig. 5 and Table I. On both SiO₂ and hBN a straddling band gap configuration appears due to the wide gaps of the substrates (see panels (a) and (c)). On TiO₂ the conduction band offsets are very close and may form a staggered band gap (panel (b)), which could lead to substantial electron (hole) transfer to TiO₂ (SL WS₂). This may explain our previous observation of less electron doping of SL WS₂ on TiO₂ compared to other oxides [9].

This simple construction suggests that χ_{WS_2} is sub-

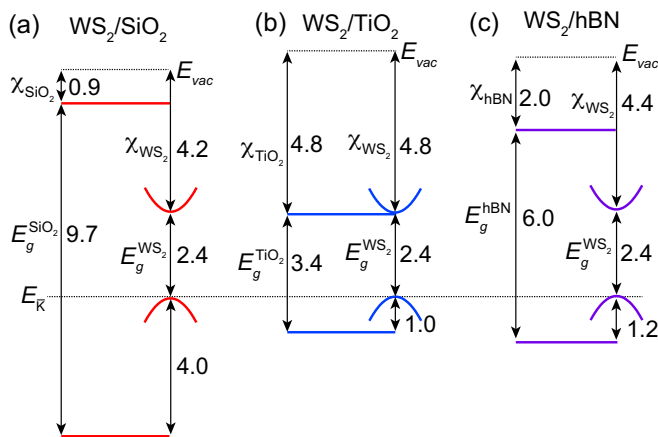

FIG. 5. SL WS₂ band alignments with (a) SiO₂, (b) TiO₂ and (c) hBN. The SL WS₂ VBM at \bar{K} is used as a general reference for the three systems (see horizontal dotted line). All values are given in units of eV. The error bars on the VB offsets and χ_{WS_2} are ± 0.1 eV. Literature values for E_g and χ are summarized in Table I.

Substrate	ϵ	E_g (eV)	χ (eV)	$E - E_{\bar{K}}^{\text{WS}_2}$ (eV)
SiO ₂	3.9	9.7 [30]	0.9 [31]	4.0
TiO ₂	113	3.4 [32]	4.8 [33]	1.0
hBN	4.0	6.0 [34]	2.0 [35]	1.2

TABLE I. Summary of dielectric constants ϵ , quasiparticle band gaps E_g , electron affinities χ and band offsets with respect to \bar{K} of SL WS₂ for SiO₂, TiO₂ and hBN.

strate dependent and generally larger than a recently determined theoretical value of 3.75 eV [11]. Caution should be exercised when considering the values here because of the variation in literature values of χ for the substrates. This issue is most pronounced in the case of χ_{hBN} where we used an often cited value of 2.0 eV [35] in Fig. 5(c). However, a value of 1.1 eV can also be found [36] and even a negative χ_{hBN} has been suggested [37]. Note also that on TiO₂ the Nb doping as well

as annealing- and beam-induced oxygen vacancies may modify the band offsets from their intrinsic values [38], which could lead to an overestimation of χ_{WS_2} . Additionally, the simple electron affinity rule may break down due to a substrate dependent quasiparticle band gap of SL WS₂ or possibly due to unusually strong interfacial dipoles that vary between substrates [7].

In conclusion, we have fabricated SL WS₂/hBN heterostructures supported on SiO₂ and TiO₂ substrates implementing device architectures in photoemission spectroscopy experiments that we believe will be compatible with charge transport measurements in gated conditions and with current passing through the materials [39]. The electronic transport properties of these mixed 2D-3D junctions will be defined by the vertical band alignments which we here inferred using an electron affinity rule incorporating the measured VB offsets.

SUPPLEMENTARY MATERIAL

See online Supplementary Material for further details on PEEM measurements, for the sample fabrication procedure and for the determination of the SiO₂, TiO₂ and hBN VB offsets.

ACKNOWLEDGEMENT

S. U. acknowledges financial support from VILLUM FONDEN (Grant. No. 15375). R. J. K. is supported by a fellowship within the Postdoc-Program of the German Academic Exchange Service (DAAD). D. S. acknowledges financial support from the Netherlands Organisation for Scientific Research under the Rubicon Program (Grant 680-50-1305). The Advanced Light Source is supported by the Director, Office of Science, Office of Basic Energy Sciences, of the U.S. Department of Energy under Contract No. DE-AC02-05CH11231. This work was supported by IBS-R009-D1. The work at NRL was supported by core programs and the Nanoscience Institute.

-
- [1] B. Radisavljevic, A. Radenovic, J. Brivio, V. Giacometti, and A. Kis, *Nature nanotechnology* **6**, 147 (2011).
 - [2] Q. Wang, K. Kourosh, A. Kis, J. Coleman, and M. Strano, *Nature Nanotechnology* **7**, 699 (2012).
 - [3] D. Jariwala, V. K. Sangwan, D. J. Late, J. E. Johns, V. P. Dravid, T. J. Marks, L. J. Lauhon, and M. C. Hersam, *Appl. Phys. Lett.* **102**, 173107 (2013).
 - [4] D. Jariwala, V. K. Sangwan, L. J. Lauhon, T. J. Marks, and M. C. Hersam, *ACS Nano* **8**, 1102 (2014).
 - [5] Y. Gong, J. Lin, X. Wang, G. Shi, S. Lei, Z. Lin, X. Zou, G. Ye, R. Vajtai, B. I. Yakobson, H. Terrones, M. Terrones, B. K. Tay, J. Lou, S. T. Pantelides, Z. Liu, W. Zhou, and P. M. Ajayan, *Nature Materials* **13**, 1135 (2014).
 - [6] A. Allain, J. Kang, K. Banerjee, and A. Kis, *Nature Materials* **14**, 1195 (2015).
 - [7] R. Schlaf, O. Lang, C. Pettenkofer, and W. Jaegermann, *Journal of Applied Physics* **85**, 2732 (1999).
 - [8] S. McDonnell, A. Azcatl, R. Addou, C. Gong, C. Battaglia, S. Chuang, K. Cho, A. Javey, and R. M. Wallace, *ACS Nano* **8**, 6265 (2014).
 - [9] S. Ulstrup, J. Katoch, R. Koch, D. Schwarz, S. Singh, K. McCreary, H. Yoo, J. Xu, B. Jonker, R. Kawakami, A. Bostwick, E. Rotenberg, and C. Jozwiak, *ACS Nano* **10**, 10058 (2016).
 - [10] D. Jariwala, T. J. Marks, and M. C. Hersam, *Nature Materials* **16**, 170 (2016).

- [11] Y. Guo and J. Robertson, *Applied Physics Letters* **108**, 233104 (2016).
- [12] A. Klein, *Thin Solid Films* **520**, 3721 (2012), 7th International Symposium on Transparent Oxide Thin Films for Electronics and Optics (TOEO-7).
- [13] Y. Fujikawa, T. Sakurai, and R. M. Tromp, *Phys. Rev. B* **79**, 121401(R) (2009).
- [14] R. J. Koch, J. Katoch, S. Moser, D. Schwarz, R. K. Kawakami, A. Bostwick, E. Rotenberg, C. Jozwiak, and S. Ulstrup, *Phys. Rev. Materials* **2**, 074006 (2018).
- [15] W. Jin, P. Yeh, N. Zaki, D. Zhang, J. Sadowski, A. Abdullah, A. Zande, D. Chenet, J. Dadap, I. Herman, P. Sutter, J. Hone, and R. Osgood, *Physical Review Letters* **111**, 106801 (2013).
- [16] W. Jin, P.-C. Yeh, N. Zaki, D. Zhang, J. T. Liou, J. T. Sadowski, A. Barinov, M. Yablonskikh, J. I. Dadap, P. Sutter, I. P. Herman, and R. M. Osgood, *Phys. Rev. B* **91**, 121409 (2015).
- [17] P.-C. Yeh, W. Jin, N. Zaki, D. Zhang, J. T. Liou, J. T. Sadowski, A. Al-Mahboob, J. I. Dadap, I. P. Herman, P. Sutter, and R. M. Osgood, *Phys. Rev. B* **91**, 041407 (2015).
- [18] K. M. McCreary, A. T. Hanbicki, G. G. Jernigan, J. C. Culbertson, and B. T. Jonker, *Scientific Reports* **6**, 19159 (2016).
- [19] J. Katoch, S. Ulstrup, R. J. Koch, S. Moser, K. McCreary, S. Singh, J. Xu, B. Jonker, R. Kawakami, A. Bostwick, E. Rotenberg, and C. Jozwiak, *Nature Physics* **14**, 355 (2018).
- [20] J.-H. Chen, C. Jang, S. Xiao, M. Ishigami, and M. S. Fuhrer, *Nature Nanotechnology* **3**, 206 (2008).
- [21] C. Dean, A. Young, I. Meric, C. Lee, L. Wang, S. Sorgenfrei, K. Watanabe, T. Taniguchi, P. Kim, K. Shepard, and J. Hone, *Nature Nanotechnology* **5**, 722 (2010).
- [22] M. Rösner, C. Steinke, M. Lorke, C. Gies, F. Jahnke, and T. O. Wehling, *Nano Letters* **16**, 2322 (2016).
- [23] A. Raja, A. Chaves, J. Yu, G. Arefe, H. M. Hill, A. F. Rigosi, T. C. Berkelbach, P. Nagler, C. Schüller, T. Korn, C. Nuckolls, J. Hone, L. E. Brus, T. F. Heinz, D. R. Reichman, and A. Chernikov, *Nature Communications* **8**, 15251 (2017).
- [24] S. Ghatak, A. N. Pal, and A. Ghosh, *ACS Nano* **5**, 7707 (2011).
- [25] E. Khestanova, F. Guinea, L. Fumagalli, A. K. Geim, and I. V. Grigorieva, *Nature Communications* **7**, 12587 (2016).
- [26] A. Klein, S. Tiefenbacher, V. Eyert, C. Pettenkofer, and W. Jaegermann, *Phys. Rev. B* **64** (2001).
- [27] H. Yuan, Z. Liu, G. Xu, B. Zhou, S. Wu, D. Dumcenco, K. Yan, Y. Zhang, S.-K. Mo, P. Dudin, V. Kandyba, M. Yablonskikh, A. Barinov, Z. Shen, S. Zhang, Y. Huang, X. Xu, Z. Hussain, H. Y. Hwang, Y. Cui, and Y. Chen, *Nano Letters* **16**, 4738 (2016).
- [28] C. H. Lui, L. Liu, K. F. Mak, G. W. Flynn, and T. F. Heinz, *Nature* **462**, 339 (2009).
- [29] A. Chernikov, A. Zande, H. Hill, A. Rigosi, A. Velauthapillai, J. Hone, and T. Heinz, *Physical Review Letters* **115**, 126802 (2015).
- [30] G. Kresse, M. Marsman, L. E. Hintzsche, and E. Flage-Larsen, *Phys. Rev. B* **85**, 045205 (2012).
- [31] R. Williams, *Phys. Rev.* **140**, A569 (1965).
- [32] M. Landmann, E. Rauls, and W. G. Schmidt, *Journal of Physics: Condensed Matter* **24**, 195503 (2012).
- [33] D. O. Scanlon, C. W. Dunnill, J. Buckeridge, S. A. Shevlin, A. J. Logsdail, S. M. Woodley, C. R. A. Catlow, M. J. Powell, R. G. Palgrave, I. P. Parkin, G. W. Watson, T. W. Keal, P. Sherwood, A. Walsh, and A. A. Sokol, *Nature Materials* **12**, 798 (2013).
- [34] B. Arnaud, S. Lebegue, P. Rabiller, and M. Alouani, *Phys. Rev. Lett.* **96**, 026402 (2006).
- [35] M. Sup Choi, G.-H. Lee, Y.-J. Yu, D.-Y. Lee, S. Hwan Lee, P. Kim, J. Hone, and W. Jong Yoo, *Nature Communications* **4**, 1624 (2013).
- [36] G. Fiori, A. Betti, S. Bruzzone, and G. Iannaccone, *ACS Nano* **6**, 2642 (2012).
- [37] M. J. Powers, M. C. Benjamin, L. M. Porter, R. J. Neumanich, R. F. Davis, J. J. Cuomo, G. L. Doll, and S. J. Harris, *Applied Physics Letters* **67**, 3912 (1995).
- [38] K. Onda, B. Li, and H. Petek, *Physical Review B* **70**, 045415 (2004).
- [39] A. Kaminski, S. Rosenkranz, M. R. Norman, M. Randeria, Z. Z. Li, H. Raffy, and J. C. Campuzano, *Phys. Rev. X* **6**, 031040 (2016).