

Secrecy Rates for a Channel With Two Senders and Two Receivers

Hassan ZivariFard, Matthieu Bloch, *Senior Member, IEEE*, and Aria Nosratinia,
Fellow, IEEE

Abstract

Motivated in part by the problem of secure multicast distributed storage, we analyze secrecy rates for a channel in which two transmitters simultaneously multicast to two receivers in the presence of an eavesdropper. Achievable rates are calculated via extensions of a technique due to Chia and El Gamal and also the method of output statistics of random binning. An intriguing synergy is observed between the achievable rate expressions arising from the two techniques: the rate region of the latter is simplified via a constraint that is discovered while deriving the former rate region. Outer bounds are derived for both the degraded and non-degraded versions of the channel, and examples are provided in which the inner and outer bounds meet. The inner bounds recover known results for the multiple-access wiretap channel, broadcast channel with confidential messages, and the compound MAC channel. An auxiliary result is also produced that characterizes the minimal randomness necessary to achieve secrecy in multiple-access wiretap channels.

I. INTRODUCTION

In 1974, Ahlswede calculated the capacity of a channel with two senders and two receivers in a work [1] that proved highly influential for the MAC channel [2] and the interference channel [3]. We study the corresponding secrecy problem (Fig. 1), in which both transmitters send messages simultaneously to both receivers in the presence of an eavesdropper, and all senders, receivers, and eavesdropper are at different terminals. This problem is motivated in part by secure access

H. ZivariFard and A. Nosratinia are with Department of Electrical Engineering, The University of Texas at Dallas, Richardson, TX, USA. M. Bloch is with School of Electrical and Computer Engineering, Georgia Institute of Technology, Atlanta, GA, USA. E-mail: hassan@utdallas.edu, matthieu.bloch@ece.gatech.edu, aria@utdallas.edu.

The material in this paper was presented in part at the 55th Annual Allerton Conference on Communication, Control, and Computing, Monticello, IL, September 2017.

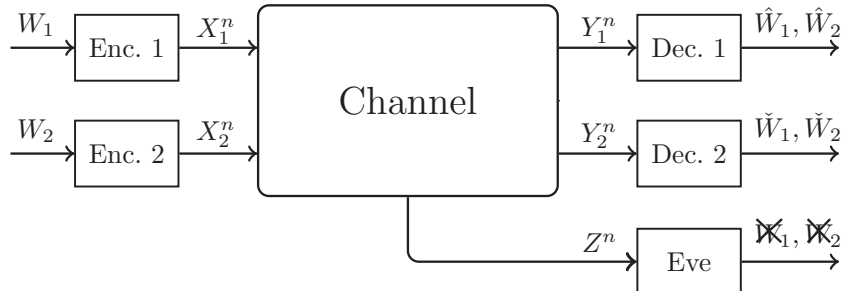

Fig. 1. Two-sender two-receiver channel with an eavesdropper

of multiple users to data in a distributed cache, which is a multi-transmitter (multiple-access) multicast scenario [4], [5]. This problem is also equivalent to a compound two-state multiple-access wiretap channel. It has been known [6] that problems involving compound channels have an equivalent multicast representation, in which the channel to each multicast receiver is equivalent to one of the states of the compound channel.

In recent years the study of *strong* and *semantic* secrecy has gained momentum [7], [8], motivated by its operational significance and enabled by the introduction and/or increased popularity of new achievability techniques such as resolvability [9]–[11] and output statistics of random binning (OSRB) [12]. Strong secrecy implies weak secrecy, reducing the motivation to study the latter when the former is tractable. That said, weak secrecy retains interest and utility because the codebook design techniques that are aimed at weak and strong secrecy can produce different achievable rate expressions, especially in complex networks. This work studies two different achievability methods, one of which yields weak secrecy and the other, strong secrecy. The achievable rate of the latter method is simplified by introducing a constraint that appears through the derivation of the secrecy region of the former.

These achievability techniques are related to two recent results in network information theory [12], [13]. First, the method of Chia and El Gamal [13] uses Marton coding and indirect decoding (also known as non-unique decoding) [14] to achieve an improved secrecy rate for the transmission of a common message to two receivers that may experience different channel statistics. In particular, [13, Lemma 1] gives an upper bound on the number of codewords that are typical with an eavesdropper’s received sequence. We extend the method of Chia and El Gamal to multiple transmitters, and introduce a corresponding two-level Marton-type coding

with associated non-unique decoding.

The second method, OSRB [12] (see also [15] for a related approach), analyzes channel coding problems by conversion to a related source coding problem, where it tests achievability by probability approximation rather than counting arguments on typical sets. A reverse conversion is needed to complete the analysis. OSRB is well suited for secrecy problems, which are also associated with probability approximation. OSRB encoding is purely by random binning and is enabled by (and named after) the following key result: applying two independent random binning schemes on the same set, the two bin indices are statistically independent as long as binning rates are sufficiently small. We extend the tools and techniques of OSRB to match the requirements of the two-transmitter multicast problem.

In addition to extending, modifying, and adapting these two techniques for a multi-transmitter setting, our work showcases their relative merit and their relation to each other in a new context. This is independently of interest because the issue of the relative size of the achievability region provided by these two techniques has been broached [12], where it was shown that in one specific problem OSRB can provide a larger achievable rate region, but in a broader sense the question remains open and is of interest to the community.

Finally, outer bounds for degraded and non-degraded channels are derived and shown to be tight against inner bounds in some special cases. In addition, the extension of the method of Chia and El Gamal is utilized to highlight the minimal amount of randomness required to achieve secrecy rates of the multiple-access wiretap channel, and that therein channel prefixing can be replaced with superposition, in a manner reminiscent of Watanabe and Oohama [16] for minimizing the randomness resources for secrecy encoding. Part of the results, including the proof of the outer bounds, are available in the conference version of this paper [17] and are not duplicated here in the interest of brevity.

A brief outline of the related literature is as follows. Multicasting with common information in the presence of an eavesdropper has been studied in [18], [19], deriving inner bounds on secrecy capacity, and in some special cases also deriving secrecy capacity region. Salehkalaibar *et al.* [18] studied a one-receiver, two-eavesdropper broadcast channel with three degraded message sets. Ekrem and Ulukus [19] studied the transmission of public and confidential messages to two legitimate users, in the presence of an eavesdropper. Benammar and Piantanida [20] calculated the secrecy capacity region of some classes of wiretap broadcast channels.

The MAC wiretap channel has been investigated in [21]–[27]. In [21], a discrete memoryless

MAC with confidential messages has been studied that consists of a MAC with generalized feedback [28] where each user's message must be kept confidential from the other. The multiple access wiretap channel [22], [23], [27] consists of a MAC with an additional channel output to an eavesdropper. In [22], [23], achievable rate regions for the secrecy capacity region have been derived. Secrecy in the interference channel and broadcast channel has been studied in [29], where inner and outer bounds for the broadcast channel with confidential messages and the interference channel with confidential messages have been compared.

This paper is organized as follows. Section II describes the notation and the system model. Section III presents a general inner bound on the secrecy capacity region under the weak secrecy regime. Section IV produces an outer bound for the degraded model and discusses its implications. Section V derives a general outer bound and provides an example where this outer bound is optimal. Section VI presents a general achievable rate region under the strong secrecy regime.

II. PRELIMINARIES

Throughout this paper, random variables are denoted by capital letters and their realizations by lower case letters. The set of ϵ -strongly jointly typical sequences of length n , according to $p_{X,Y}$, is denoted by $\mathcal{T}_\epsilon^{(n)}(p_{X,Y})$. For convenience in notation, whenever there is no danger of confusion, typicality will reference the random variables rather than the distribution, e.g., $\mathcal{T}_\epsilon^{(n)}(X, Y)$. The set of sequences $\{x^n : (x^n, y^n) \in \mathcal{T}_\epsilon^{(n)}(X, Y)\}$ for a fixed y^n , when the fixed sequence y^n is clear from the context, is denoted with the shorthand notation $\mathcal{T}_\epsilon^{(n)}(X|Y)$. Superscripts denote the dimension of a vector, e.g., X^n . The integer set $\{1, \dots, M\}$ is denoted by $\llbracket 1, M \rrbracket$, and $X_{[i:j]}$ indicates the set $\{X_i, X_{i+1}, \dots, X_j\}$. The cardinality of a set is denoted by $|\cdot|$. We utilize the total variation between probability mass functions (pmfs), defined by $\|q - p\|_1 = \frac{1}{2} \sum_x |p - q|$. Also, following Cuff [30] we use the concept of random pmfs denoted by capital letters (e.g. P_X).

Definition 1. A $(M_{1,n}, M_{2,n}, n)$ code for the considered model (Fig. 1) consists of the following:

- i) Two message sets $\mathcal{W}_i = \llbracket 1, M_{i,n} \rrbracket$, $i = 1, 2$, from which independent messages W_1 and W_2 are drawn uniformly distributed over their respective sets.
- ii) Stochastic encoders f_i , $i = 1, 2$, which are specified by conditional probability matrices $f_i(X_i^n | w_i)$, where $X_i^n \in \mathcal{X}_i^n$, $w_i \in \mathcal{W}_i$ are channel inputs and private messages, respectively,

and $\sum_{x_i^n} f_i(x_i^n|w_i) = 1$. Here, $f_i(x_i^n|w_i)$ is the probability of the encoder producing the codeword x_i^n for the message w_i .

iii) A decoding function $\phi_1 : \mathcal{Y}_1^n \rightarrow \mathcal{W}_1 \times \mathcal{W}_2$ that assigns $(\hat{w}_1, \hat{w}_2) \in \llbracket 1, M_{1,n} \rrbracket \times \llbracket 1, M_{2,n} \rrbracket$ to received sequence y_1^n .

iv) A decoding function $\phi_2 : \mathcal{Y}_2^n \rightarrow \mathcal{W}_1 \times \mathcal{W}_2$ that assigns $(\check{w}_1, \check{w}_2) \in \llbracket 1, M_{1,n} \rrbracket \times \llbracket 1, M_{2,n} \rrbracket$ to received sequence y_2^n .

The probability of error is given by:

$$P_e \triangleq \mathbb{P}(\{(\hat{W}_1, \hat{W}_2) \neq (W_1, W_2)\} \cup \{(\check{W}_1, \check{W}_2) \neq (W_1, W_2)\}). \quad (1)$$

Definition 2 ([31]). A rate pair (R_1, R_2) is said to be achievable under weak secrecy if there exists a sequence of $(M_{1,n}, M_{2,n}, n)$ codes with $M_{1,n} \geq 2^{nR_1}$, $M_{2,n} \geq 2^{nR_2}$, so that $P_e \xrightarrow{n \rightarrow \infty} 0$ and

$$\frac{1}{n} \mathbb{I}(W_1, W_2; Z^n) \xrightarrow{n \rightarrow \infty} 0. \quad (2)$$

Definition 3. A rate pair (R_1, R_2) is said to be achievable under strong secrecy if there exists a sequence of $(M_{1,n}, M_{2,n}, n)$ codes with $M_{1,n} \geq 2^{nR_1}$, $M_{2,n} \geq 2^{nR_2}$, so that $P_e \xrightarrow{n \rightarrow \infty} 0$ and

$$\mathbb{I}(W_1, W_2; Z^n) \xrightarrow{n \rightarrow \infty} 0. \quad (3)$$

Definition 4. $p_X \approx q_X$ indicates $\|p_X - q_X\|_1 < \epsilon$. For two random pmfs [30], $P_X \approx Q_X$ indicates $\mathbb{E}\|P_X - Q_X\|_1 < \epsilon$.

III. ACHIEVABLE RATE REGION FOR THE WEAK SECRECY REGIME

We start with a lemma that fits Marton coding with indirect decoding in a MAC structure and produces an entropy bound needed in the secrecy analysis. Its basic idea can be highlighted as follows: given X^n , if we *independently* produce 2^{nR} random codevectors Y^n , we will have approximately $2^{nR - \mathbb{I}(X^n; Y^n)}$ jointly typical pairs, i.e., the “excess” rate will determine the number of jointly typical pairs. This lemma extends the basic idea of excess rate to multiple codebooks, multiple conditioning, and furthermore, a generalization is made from a counting argument to the entropy of the index of the codebook, which is essential for secrecy analysis.

Lemma 1. Consider random variables $(Q, U_0, V_0, U_1, V_1, Z)$ distributed according to $p(q, u_0, v_0, u_1, v_1, z)$. Draw random sequences Q^n, U_0^n, V_0^n according to

$\prod_{i=1}^n p_Q(q_i) p_{U_0|Q}(u_{0,i}|q_i) p_{V_0|Q}(v_{0,i}|q_i)$. Conditioned on U_0^n , draw 2^{nS} i.i.d. copies of U_1^n according to $\prod_{i=1}^n p_{U_1|U_0}(u_{1,i}|u_{0,i})$, denoted $U_1^n(\ell)$, $\ell \in \llbracket 1, 2^{nS} \rrbracket$. Similarly, conditioned on V_0^n , draw 2^{nT} i.i.d. copies of V_1^n according to $\prod_{i=1}^n p_{V_1|V_0}(v_{1,i}|v_{0,i})$, denoted $V_1^n(k)$, $k \in \llbracket 1, 2^{nT} \rrbracket$. Let $L \in \llbracket 1, 2^{nS} \rrbracket$ and $K \in \llbracket 1, 2^{nT} \rrbracket$ be random variables with arbitrary pmf. If

$$S > \mathbb{I}(U_1; Z|Q, U_0, V_0) + \delta_1(\epsilon)$$

$$T > \mathbb{I}(V_1; Z|Q, U_0, V_0) + \delta_1(\epsilon)$$

$$S + T > \mathbb{I}(U_1, V_1; Z|Q, U_0, V_0) + \delta_1(\epsilon)$$

for a positive $\delta_1(\epsilon)$ and if for an arbitrary sequence Z^n ,

$$\mathbb{P}((Q^n, U_0^n, V_0^n, U_1^n(L), V_1^n(K), Z^n) \in \mathcal{T}_\epsilon^{(n)}) \xrightarrow{n \rightarrow \infty} 1$$

there exists a positive $\delta_2(\epsilon) \xrightarrow{\epsilon \rightarrow 0} 0$, such that for n sufficiently large

$$\mathbb{H}(L, K|Q^n, U_0^n, V_0^n, Z^n, \mathcal{C}) \leq n(S + T - \mathbb{I}(U_1, V_1; Z|Q, U_0, V_0)) + n\delta_2(\epsilon). \quad (4)$$

where $\mathcal{C} = \{U_1^n(1), \dots, U_1^n(2^{nS}), V_1^n(1), \dots, V_1^n(2^{nT})\}$.

The proof is provided in Appendix A.

This result is related to, and contains, [13, Lemma 1]. In particular, [13] considers a single-input channel and explores the properties of codebooks driven by this input, while observing an output Z . In contrast, this paper's Lemma 1 develops a corresponding result for a *multiple-access channel* with respect to Z , motivated by the two-transmitters present in the model of this paper. This accounts for the new features of our Lemma 1, namely three rate constraints instead of one, as well as monitoring the entropy of two index random variables instead of one. Furthermore, the present result has one additional layer of conditioning to allow for indirect decoding of multiple confidential messages in the sequel, while in [13] only one confidential message is decoded.

Remark 1. *In addition to enabling the main results of this paper, Lemma 1 also has broader implications on the necessity of prefixing in multi-transmitter secrecy problems [32] and deriving the minimum amount of randomness needed to achieve secrecy. Csiszár and Körner introduced prefixing in [33] to expand the achievable rate region of the non-degraded broadcast channel with confidential messages, a technique that was subsequently used in essentially the same manner in multi-transmitter settings. Subsequently, Chia and El Gamal showed that in a single-transmitter wiretap channel, prefixing can be replaced with superposition coding [13]. Appendix B extends*

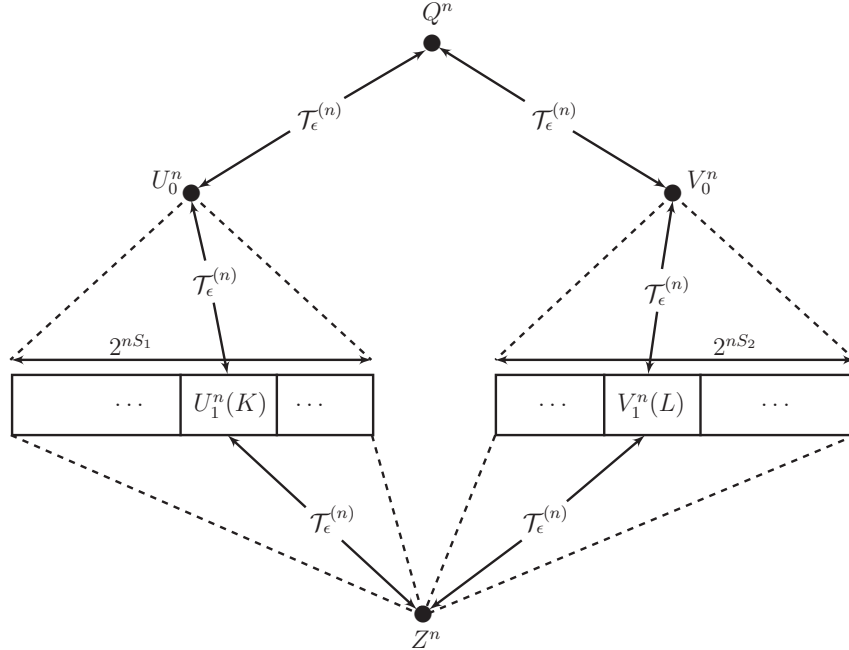

Fig. 2. Structure of Lemma 1: subject to jointly typical sequences $(Q^n, U_0^n, V_0^n, U_1^n(K), V_1^n(L), Z^n)$, finding a bound on the conditional entropy of (K, L) , thus implicitly bounding the number of sequence pairs that can be jointly typical with (Q^n, Z^n) from codebooks with certain size.

this concept to a multi-transmitter setting and presents an achievability technique for the multiple access wiretap channel that utilizes minimal randomness and matches the best known achievable rates without prefixing.

Theorem 1. *An inner bound on the secrecy capacity region of the two-transmitter two-receiver channel with confidential messages is given by the set of non-negative rate pairs (R_1, R_2) such that*

$$R_1 \leq \mathbb{I}(U_0, U_1; Y_1|Q, V_0, V_1) - \mathbb{I}(U_0; Z|Q) - \mathbb{I}(U_1; Z|Q, U_0, V_0), \quad (5)$$

$$R_1 \leq \mathbb{I}(U_0, U_2; Y_2|Q, V_0, V_2) - \mathbb{I}(U_0; Z|Q) - \mathbb{I}(U_2; Z|Q, U_0, V_0), \quad (6)$$

$$R_2 \leq \mathbb{I}(V_0, V_1; Y_1|Q, U_0, U_1) - \mathbb{I}(V_0; Z|Q) - \mathbb{I}(V_1; Z|Q, U_0, V_0), \quad (7)$$

$$R_2 \leq \mathbb{I}(V_0, V_2; Y_2|Q, U_0, U_2) - \mathbb{I}(V_0; Z|Q) - \mathbb{I}(V_2; Z|Q, U_0, V_0), \quad (8)$$

$$R_1 + R_2 \leq \mathbb{I}(U_0, U_1, V_0, V_1; Y_1|Q) - \mathbb{I}(U_0, U_1, V_0, V_1; Z|Q), \quad (9)$$

$$R_1 + R_2 \leq \mathbb{I}(U_0, U_2, V_0, V_2; Y_2|Q) - \mathbb{I}(U_0, U_2, V_0, V_2; Z|Q), \quad (10)$$

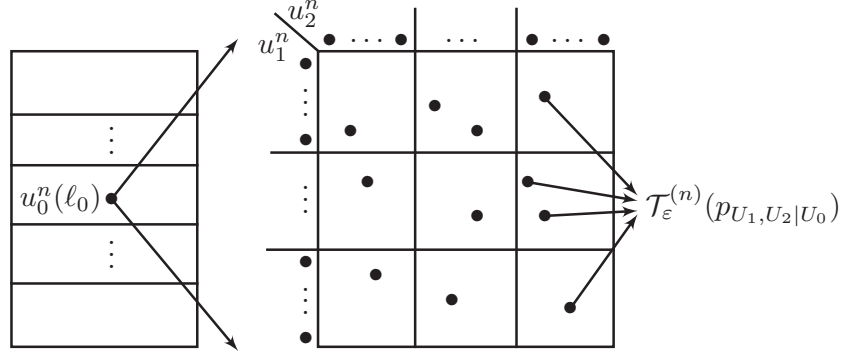

Fig. 3. Coding scheme for the first transmitter

$$\begin{aligned}
 R_1 + R_2 &\leq \mathbb{I}(U_0, U_1; Y_1 | Q, V_0, V_1) + \mathbb{I}(V_0, V_2; Y_2 | Q, U_0, U_2) \\
 &\quad - \mathbb{I}(U_0, V_0; Z | Q) - \mathbb{I}(U_1; Z | Q, U_0, V_0) - \mathbb{I}(V_2; Z | Q, U_0, V_0), \tag{11}
 \end{aligned}$$

$$\begin{aligned}
 R_1 + R_2 &\leq \mathbb{I}(V_0, V_1; Y_1 | Q, U_0, U_1) + \mathbb{I}(U_0, U_2; Y_2 | Q, V_0, V_2) \\
 &\quad - \mathbb{I}(U_0, V_0; Z | Q) - \mathbb{I}(U_2; Z | Q, U_0, V_0) - \mathbb{I}(V_1; Z | Q, U_0, V_0), \tag{12}
 \end{aligned}$$

for some

$$\begin{aligned}
 &p(q)p(u_0|q)p(u_1, u_2|u_0)p(v_0|q)p(v_1, v_2|v_0) \\
 &p(x_1|u_0, u_1, u_2)p(x_2|v_0, v_1, v_2)p(y_1, y_2, z|x_1, x_2), \tag{13}
 \end{aligned}$$

such that

$$\begin{aligned}
 &\mathbb{I}(U_1, U_2, V_1, V_2; Z | U_0, V_0) \leq \mathbb{I}(U_1, V_1; Z | U_0, V_0) \\
 &\quad + \mathbb{I}(U_2, V_2; Z | U_0, V_0) - \mathbb{I}(U_1; U_2 | U_0) - \mathbb{I}(V_1; V_2 | V_0). \tag{14}
 \end{aligned}$$

The proof uses superposition coding, Wyner's wiretap coding, Marton coding, as well as indirect decoding.

This result recovers several known earlier results:

- By setting $Z = \emptyset$, $U_0 = U_1 = U_2 = X_1$, and $V_0 = V_1 = V_2 = X_2$, the result in Theorem 1 reduces to the capacity region of compound multiple access channel discussed in [1].
- By setting $Y_2 = \emptyset$ (or $Y_1 = \emptyset$), $U_0 = U_1 = U_2 = X_1$ and $V_0 = V_1 = V_2 = X_2$, the result in Theorem 1 reduces to the achievable rate region of multiple access wiretap channel without common message [22]–[24].

- By setting $X_2 = \emptyset$ (or $X_1 = \emptyset$), $U_0 = U_1 = U_2$, and $Y_2 = \emptyset$ (or $Y_1 = \emptyset$), the result in Theorem 1 reduces to the capacity region of broadcast channel with confidential message [34, Corollary 2].
- By setting $X_2 = \emptyset$ (or $X_1 = \emptyset$), the result in Theorem 1 reduces to the achievable rate region for two-receiver, one-eavesdropper wiretap channel presented in [13, Theorem 1].

Remark 2. *By doing some algebraic manipulation we can show that the constraint in (14) holds only if*

$$\mathbb{I}(U_1, V_1; U_2, V_2 | Q, U_0, V_0, Z) = 0. \quad (15)$$

Corollary 1. *An inner bound on the secrecy capacity region of degraded two-transmitter two-receiver channel with confidential messages (Definition 5) is given by the set of non-negative rate pairs (R_1, R_2) such that*

$$\begin{cases} R_1 \leq \mathbb{I}(U_0; Y_2 | V_0, Q) - \mathbb{I}(U_0; Z | Q) \\ R_2 \leq \mathbb{I}(V_0; Y_2 | U_0, Q) - \mathbb{I}(V_0; Z | Q) \\ R_1 + R_2 \leq \mathbb{I}(U_0, V_0; Y_2 | Q) - \mathbb{I}(U_0; Z | Q) - \mathbb{I}(V_0; Z | Q) \end{cases} \quad (16)$$

for some

$$p(q)p(u_0|q)p(v_0|q)p(x_1|u_0)p(x_2|v_0). \quad (17)$$

Proof. The proof follows from Theorem 1 by setting $U_0 = U_1 = U_2$ and $V_0 = V_1 = V_2$ and considering the fact that the channel is degraded. \square

IV. AN OUTER BOUND FOR THE DEGRADED MODEL

We develop an outer bound for the degraded version of the model and show an example where it meets the inner bound (Theorem 1).

Definition 5. *The degraded two-transmitter two-receiver channel with confidential messages obeys:*

$$p(y_1, y_2, z | x_1, x_2) = p(y_1 | x_1, x_2)p(y_2 | y_1)p(z | y_2). \quad (18)$$

Theorem 2. *The secrecy capacity region for the degraded two-transmitter two-receiver channel with confidential messages is included in the set of rate pairs (R_1, R_2) satisfying*

$$R_1 \leq \mathbb{I}(U_0; Y_2 | Q) - \mathbb{I}(U_0; Z | Q), \quad (19)$$

$$R_2 \leq \mathbb{I}(V_0; Y_2|Q) - \mathbb{I}(V_0; Z|Q), \quad (20)$$

$$R_1 + R_2 \leq \mathbb{I}(U_0, V_0; Y_2|Q) - \mathbb{I}(U_0, V_0; Z|Q), \quad (21)$$

for some joint distribution

$$p(q)p(u_0, v_0|q)p(x_1|u_0)p(x_2|v_0). \quad (22)$$

Proof. The proof is provided by the authors in [17, Section IV] and is omitted here for brevity. \square

Example (Degraded Switch Model): We consider an example of the two-transmitter two-receiver channel where the first legitimate receiver has access to the noisy version of each of the two transmitted values in a time-sharing (switched) manner, without interference from the other transmitter (Fig. 4). The second legitimate receiver has access to a noisy version of the first receiver, and the eavesdropper has access to a noisy version of the second receiver. The switch channel state information is made available to all terminals. In this model the channel outputs are as follows:

$$y'_1 = (y_1, s), \quad (23)$$

$$y'_2 = (y_2, s), \quad (24)$$

$$z' = (z, s). \quad (25)$$

This model consists of a channel with states that are causally available at both the encoders and decoders.

The statistics of the channel, conditioned on the switch state, are expressed as follows:

$$p(y'_1, y'_2, z|x_1, x_2, s) = p(y_1|x_1, x_2, s) p(y_2|y_1, s) p(z|y_2, s) \quad (26)$$

The switch model describes, e.g., frequency hopping over two frequencies [29]. The state (switch) is a binary random variable that chooses between listening to the Transmitter 1, with probability τ , and listening to the Transmitter 2, with probability $1 - \tau$, independently at each time slot. We further assume the state is i.i.d. across time.

$$p(y_1|x_1, x_2, s) = p(y_1|x_1)\mathbb{1}\{s = 1\} + p(y_1|x_2)\mathbb{1}\{s = 2\} \quad (27)$$

where $\mathbb{1}$ is the indicator function.

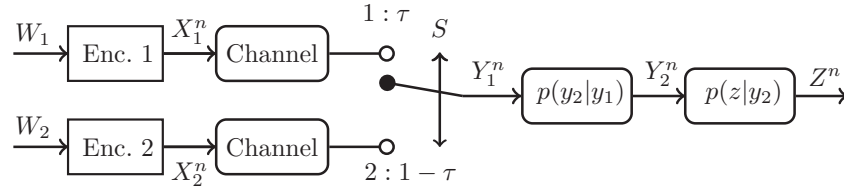

Fig. 4. Degraded switch model

Theorem 3. *The secrecy capacity region for the degraded switch two-transmitter two-receiver channel with confidential messages, is given by the set of rate pairs (R_1, R_2) satisfying*

$$R_1 \leq \mathbb{I}(U_0; Y_2' | V_0, Q) - \mathbb{I}(U_0; Z' | Q), \quad (28)$$

$$R_2 \leq \mathbb{I}(V_0; Y_2' | U_0, Q) - \mathbb{I}(V_0; Z' | Q), \quad (29)$$

$$R_1 + R_2 \leq \mathbb{I}(U_0, V_0; Y_2' | Q) - \mathbb{I}(U_0, V_0; Z' | Q), \quad (30)$$

for some joint distribution

$$p(q)p(u_0|q)p(v_0|q)p(x_1|u_0)p(x_2|v_0). \quad (31)$$

Proof. The proof is available in [17, Section IV]. \square

V. A GENERAL OUTER BOUND

We now develop a general outer bound for the model of Fig. 1 and show an example in which it meets the inner bound (Theorem 1).

Theorem 4. *The secrecy capacity region for the two-transmitter two-receiver channel with confidential messages is included in the set of rate pairs (R_1, R_2) satisfying*

$$R_1 \leq \mathbb{I}(U_0; Y_1, Y_2 | Q) - \mathbb{I}(U_0; Z | Q), \quad (32)$$

$$R_2 \leq \mathbb{I}(V_0; Y_1, Y_2 | Q) - \mathbb{I}(V_0; Z | Q), \quad (33)$$

$$R_1 + R_2 \leq \mathbb{I}(U_0, V_0; Y_1, Y_2 | Q) - \mathbb{I}(U_0, V_0; Z | Q), \quad (34)$$

for some joint distribution

$$p(q)p(u_0, v_0|q)p(x_1|u_0)p(x_2|v_0). \quad (35)$$

Proof. The proof is available in [17, Section V]. \square

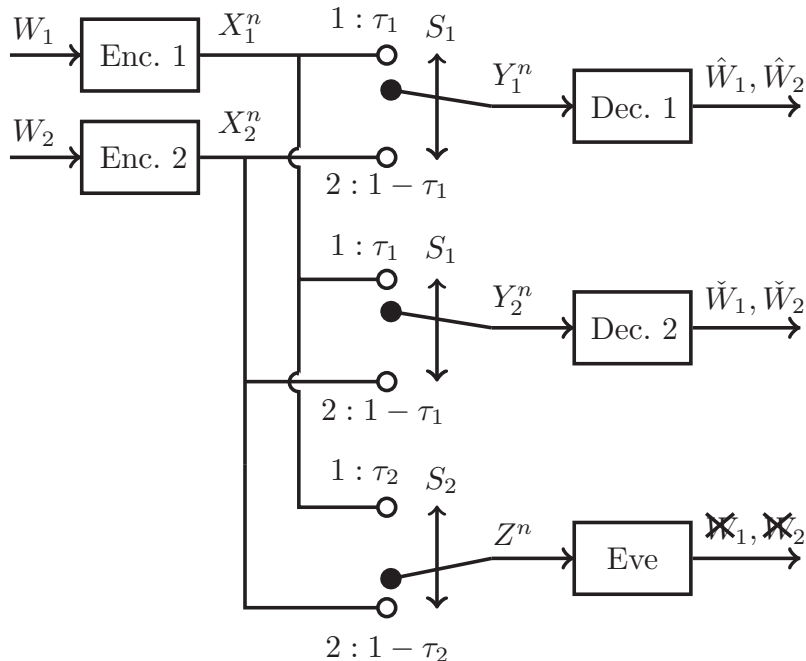

Fig. 5. Noiseless switch model

Example (Noiseless Switch Model): We consider an example of the two-transmitter two-receiver channel in which the legitimate receivers as well as eavesdropper have access to the noiseless version of each of the two transmitted values in a time-sharing (switched) manner, without interference from the other transmitter (Fig. 5). This corresponds to a situation in which transmitters operate on different spectral bands, while the receiving terminals have the capability of operating on one adaptable (time-varying) band [29]. Here, it is assumed that both legitimate receivers operate according to a common random switch s_1 that is connected to Transmitter 1 with probability τ_1 and to Transmitter 2 with probability $1 - \tau_1$, and the eavesdropper operates according to another random switch s_2 that is connected to Transmitter 1 with probability τ_2 and to Transmitter 2 with probability $1 - \tau_2$. Aside from the switches, the channel is noiseless. Both receivers and the eavesdropper have access to their own switch state information. Therefore the channel outputs are considered as follows

$$y'_1 = (y_1, s_1), \quad (36)$$

$$y'_2 = (y_2, s_1), \quad (37)$$

$$z' = (z, s_2). \quad (38)$$

Since $y_1 = y_2$, we also have $y'_1 = y'_2$.

Theorem 5. *The secrecy capacity region for the noiseless switch two-transmitter two-receiver channel with confidential messages is given by the set of rate pairs (R_1, R_2) satisfying*

$$R_1 \leq (\tau_1 - \tau_2)^+ \mathbb{H}(X_1), \quad (39)$$

$$R_2 \leq (\tau_2 - \tau_1)^+ \mathbb{H}(X_2). \quad (40)$$

Proof. The proof is available in [17, Section V]. □

Remark 3. *The capacity region in Theorem 5 shows that transmitters can securely communicate to receivers as long as $\tau_1 \neq \tau_2$.*

VI. STRONG SECRECY

Theorem 6. *An inner bound on the secrecy capacity region of the two-transmitter two-receiver channel with confidential messages consists of the union of rate pairs (R_1, R_2) regions satisfying (48)-(59), (68), (71), (76), and non-negativity constraints for all rate variables, for some distribution*

$$p(q)p(u_0, u_1, u_2|q)p(v_0, v_1, v_2|q)p(x_1|u_0, u_1, u_2)p(x_2|v_0, v_1, v_2)p(y_1, y_2, z|x_1, x_2), \quad (41)$$

Remark 4. *It is customary to simplify the rate region constraints via the Fourier-Motzkin method [35] to eliminate rate variables not associated with external messages; however, in the interest of brevity we omit the 291 inequalities resulting from Fourier-Motzkin elimination. Subsequently, a subset of this achievable rate region will be presented that enjoys a much simpler expression.*

Proof. The achievability proof is inspired by [12], [36], and is based on solving the dual secret key agreement problem in the so-called source model that includes shared randomness at all terminals (see Fig. 6). In this dual model, rate constraints are derived so that the input and output distributions of the dual model approximate that of the original model while satisfying reliability and secrecy conditions in the dual model. The probability approximation then guarantees that reliability *and* secrecy conditions can be achieved in the original model. Finally, it is shown that there exists one realization of shared randomness for which the above mentioned are valid, thus removing the necessity for common randomness.

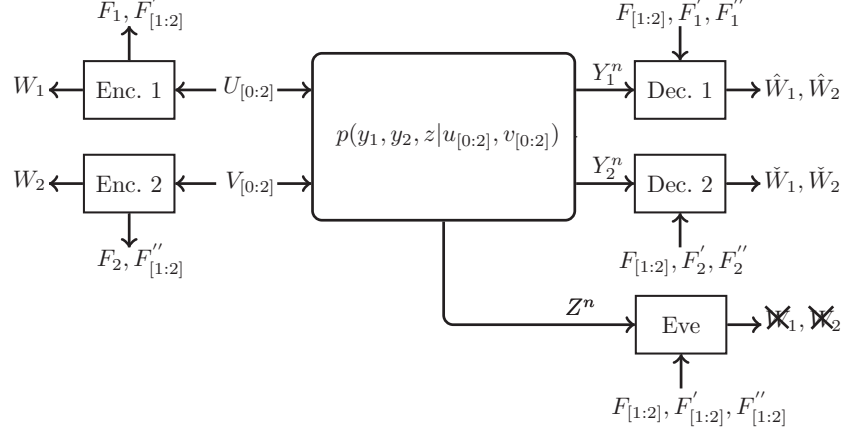

Fig. 6. Dual secret key agreement problem in the source model for the original problem.

We begin by developing the encoding and decoding strategies for the source model and the original model, and derive and compare the joint probability distributions arising from these two strategies.

We begin with the multi-terminal secret key agreement problem in the source model as depicted in Fig. 6. Let $(U_{[0:2]}^n, V_{[0:2]}^n, X_1^n, X_2^n, Y_1^n, Y_2^n, Z^n)$ be i.i.d. and distributed according to

$$p(u_{[0:2]}, x_1)p(v_{[0:2]}, x_2)p(y_1, y_2, z|x_1, x_2). \quad (42)$$

Random Binning:

- To each and every u_0^n , uniformly and independently assign two random bin indices $w_1 \in \llbracket 1, 2^{nR_1} \rrbracket$ and $f_1 \in \llbracket 1, 2^{n\tilde{R}_1} \rrbracket$.
- To each pair (u_0^n, u_j^n) for $j = 1, 2$ uniformly and independently assign random bin index $f'_j \in \llbracket 1, 2^{n\tilde{R}'_j} \rrbracket$.
- To each v_0^n uniformly and independently assign two random bin indices $w_2 \in \llbracket 1, 2^{nR_2} \rrbracket$ and $f_2 \in \llbracket 1, 2^{n\tilde{R}_2} \rrbracket$.
- To each pair (v_0^n, v_j^n) for $j = 1, 2$ uniformly and independently assign random bin index $f''_j \in \llbracket 1, 2^{n\tilde{R}''_j} \rrbracket$.
- The random variables representing bin indices are:

$$F_{[1:2]}, \quad F'_{[1:2]}, \quad F''_{[1:2]}, \quad W_{[1:2]}. \quad (43)$$

- Decoder 1 is a Slepian-Wolf decoder observing $(y_1^n, f_{[1:2]}, f'_1, f''_1)$, and producing $(\hat{u}_0^n, \hat{u}_1^n)$ and $(\hat{v}_0^n, \hat{v}_1^n)$, thus declaring $\hat{w}_1 = W_1(\hat{u}_0^n)$ and $\hat{w}_2 = W_2(\hat{v}_0^n)$ to be the estimate of the pair (w_1, w_2) .
- Decoder 2 is a Slepian-Wolf decoder observing $(y_2^n, f_{[1:2]}, f'_2, f''_2)$, and producing $(\check{u}_0^n, \check{u}_2^n)$ and $(\check{v}_0^n, \check{v}_2^n)$, thus declaring the bin indices $\check{w}_1 = W_1(\check{u}_0^n)$ and $\check{w}_2 = W_2(\check{v}_0^n)$ as the estimate of the pair (w_1, w_2) .

To condense the notation, we define the following variables:

$$\mathbf{f} \triangleq (f_{[1:2]}, f'_{[1:2]}, f''_{[1:2]}), \quad (44)$$

$$\hat{\mathbf{u}} \triangleq (\hat{u}_0^n, \check{u}_0^n, \hat{u}_1^n, \check{u}_2^n, \hat{v}_0^n, \check{v}_0^n, \hat{v}_1^n, \check{v}_2^n), \quad (45)$$

Then, the random pmf induced by random binning is as follows:

$$\begin{aligned} & P(u_{[0:2]}^n, v_{[0:2]}^n, x_{[1:2]}^n, y_1^n, y_2^n, z^n, w_{[1:2]}, \mathbf{f}, \hat{\mathbf{u}}) \\ &= p(u_{[0:2]}^n, v_{[0:2]}^n, x_{[1:2]}^n, y_1^n, y_2^n, z^n) P(w_{[1:2]}, f_{[1:2]} | u_0^n, v_0^n) P(f'_{[1:2]}, f''_{[1:2]} | u_{[0:2]}^n, v_{[0:2]}^n) \\ &\times P^{SW}(\hat{u}_0^n, \hat{u}_1^n, \hat{v}_0^n, \hat{v}_1^n | y_1^n, f_{[1:2]}, f'_1, f''_1) P^{SW}(\check{u}_0^n, \check{u}_2^n, \check{v}_0^n, \check{v}_2^n | y_2^n, f_{[1:2]}, f'_2, f''_2) \\ &= P(w_{[1:2]}, f_{[1:2]}, u_0^n, v_0^n) P(f'_{[1:2]}, f''_{[1:2]}, u_{[1:2]}^n, v_{[1:2]}^n | u_0^n, v_0^n) \\ &\times p(x_1^n | u_{[0:2]}^n) p(x_2^n | v_{[0:2]}^n) p(y_1^n, y_2^n, z^n | x_1^n, x_2^n) \\ &\times P^{SW}(\hat{u}_0^n, \hat{u}_1^n, \hat{v}_0^n, \hat{v}_1^n | y_1^n, f_{[1:2]}, f'_1, f''_1) P^{SW}(\check{u}_0^n, \check{u}_2^n, \check{v}_0^n, \check{v}_2^n | y_2^n, f_{[1:2]}, f'_2, f''_2) \\ &= P(w_{[1:2]}, f_{[1:2]}) P(u_0^n, v_0^n | w_{[1:2]}, f_{[1:2]}) P(f'_{[1:2]}, f''_{[1:2]} | u_0^n, v_0^n) P(u_{[1:2]}^n, v_{[1:2]}^n | u_0^n, v_0^n, f'_{[1:2]}, f''_{[1:2]}) \\ &\times p(x_1^n | u_{[0:2]}^n) p(x_2^n | v_{[0:2]}^n) p(y_1^n, y_2^n, z^n | x_1^n, x_2^n) \\ &\times P^{SW}(\hat{u}_0^n, \hat{u}_1^n, \hat{v}_0^n, \hat{v}_1^n | y_1^n, f_{[1:2]}, f'_1, f''_1) P^{SW}(\check{u}_0^n, \check{u}_2^n, \check{v}_0^n, \check{v}_2^n | y_2^n, f_{[1:2]}, f'_2, f''_2). \end{aligned} \quad (46)$$

P^{SW} denotes the pmf of the output of the Slepian-Wolf decoder, which is a random pmf. Here \hat{W}_1, \hat{W}_2 and \check{W}_1, \check{W}_2 are omitted because they are functions of other random variables.

We now return to the original problem, represented by Fig. 1, except that, in addition, a genie provides all terminals with a shared randomness described by $(F_{[1:2]}, F'_{[1:2]}, F''_{[1:2]})$, whose distribution will be clarified in the sequel. In this augmented model:

- The messages W_1, W_2 are mutually independent and uniformly distributed with rates R_1, R_2 respectively. Also, shared randomness F_1, F_2 are uniformly distributed over $\llbracket 1, 2^{n\tilde{R}_1} \rrbracket$ and $\llbracket 1, 2^{n\tilde{R}_2} \rrbracket$, independent of each other, and of W_1, W_2

- Encoder 1 and 2 are stochastic encoders producing codewords U_0^n, V_0^n according to distributions $P(u_0^n|w_{[1:2]}, f_{[1:2]})$ and $P(v_0^n|w_{[1:2]}, f_{[1:2]})$, respectively, which are the marginals of distribution $P(u_0^n, v_0^n|w_{[1:2]}, f_{[1:2]})$ appearing in (46). (Thus we are beginning to establish the connection between the two models).
- The four random variables $F'_{[1:2]}, F''_{[1:2]}$ are mutually independent and uniformly distributed over, respectively, $\llbracket 1, 2^{n\tilde{R}'_1} \rrbracket$ and $\llbracket 1, 2^{n\tilde{R}'_2} \rrbracket$, $\llbracket 1, 2^{n\tilde{R}''_1} \rrbracket$ and $\llbracket 1, 2^{n\tilde{R}''_2} \rrbracket$. They are also independent of (U_0^n, V_0^n) therefore they are independent of $(W_{[1:2]}, F_{[1:2]})$.
- Encoder 1 and 2 further generate $U_{[1:2]}^n, V_{[1:2]}^n$ according to $P(u_{[1:2]}^n|u_0^n, v_0^n, f'_{[1:2]}, f''_{[1:2]})$ and $P(v_{[1:2]}^n|u_0^n, v_0^n, f'_{[1:2]}, f''_{[1:2]})$, respectively, which are marginal distributions of $P(u_{[1:2]}^n, v_{[1:2]}^n|u_0^n, v_0^n, f'_{[1:2]}, f''_{[1:2]})$ from (46).
- Encoder 1 generates X_1^n i.i.d. according to $p(x_1|u_{[0:2]})$. Encoder 2 generates X_2^n i.i.d. according to $p(x_2|v_{[0:2]})$. X_1, X_2 are transmitted over the channel.
- Decoders 1 and 2 are Slepian-Wolf decoders copied from the source model secret key agreement problem, observing respectively $(y_1^n, f_{[1:2]}, f'_1, f''_1)$ and $(y_2^n, f_{[1:2]}, f'_2, f''_2)$, and producing $(\hat{u}_0^n, \hat{u}_1^n, \hat{v}_0^n, \hat{v}_1^n)$ and $(\check{u}_0^n, \check{u}_2^n, \check{v}_0^n, \check{v}_2^n)$. Therefore the following random PMFs for the decoder output distributions are inherited from the source model:

$$P^{SW}(\hat{u}_0^n, \hat{u}_1^n, \hat{v}_0^n, \hat{v}_1^n|y_1^n, f_{[1:2]}, f'_1, f''_1)$$

$$P^{SW}(\check{u}_0^n, \check{u}_2^n, \check{v}_0^n, \check{v}_2^n|y_2^n, f_{[1:2]}, f'_2, f''_2)$$

- Decoders 1 and 2 then produce estimates of (W_1, W_2) , which are denoted (\hat{W}_1, \hat{W}_2) and $(\check{W}_1, \check{W}_2)$ respectively.

The random pmf induced by the random binning and the encoding/decoding strategy is as follows:

$$\begin{aligned} & \hat{P}(u_{[0:2]}^n, v_{[0:2]}^n, y_1^n, y_2^n, z^n, w_{[1:2]}, \mathbf{f}, \hat{\mathbf{u}}) \\ &= p^U(w_{[1:2]})p^U(f_{[1:2]})P(u_0^n, v_0^n|w_{[1:2]}, f_{[1:2]})p^U(f'_{[1:2]})p^U(f''_{[1:2]})P(u_{[1:2]}^n, v_{[1:2]}^n|u_0^n, v_0^n, f'_{[1:2]}, f''_{[1:2]}) \\ & \times p(x_1^n|u_{[0:2]}^n)p(x_2^n|v_{[0:2]}^n)p(y_1^n, y_2^n, z^n|x_1^n, x_2^n) \\ & \times P^{SW}(\hat{u}_0^n, \hat{u}_1^n, \hat{v}_0^n, \hat{v}_1^n|y_1^n, f_{[1:2]}, f'_1, f''_1)P^{SW}(\check{u}_0^n, \check{u}_2^n, \check{v}_0^n, \check{v}_2^n|y_2^n, f_{[1:2]}, f'_2, f''_2). \end{aligned} \quad (47)$$

where \mathbf{f} and $\hat{\mathbf{u}}$ are defined in (44) and (45), respectively,

We now find constraints that ensure that the pmfs \hat{P} and P are close in total variation distance. For the source model secret key agreement problem, substituting $X_1 = X_2 \leftarrow U_0$, and $X_3 = X_4 \leftarrow V_0$, in [12, Theorem 1] implies that $W_{[1:2]}$ is nearly independent of $F_{[1:2]}$ and Z^n , if

$$R_1 + \tilde{R}_1 \leq \mathbb{H}(U_0|Z), \quad (48)$$

$$R_2 + \tilde{R}_2 \leq \mathbb{H}(V_0|Z), \quad (49)$$

$$R_1 + \tilde{R}_1 + R_2 + \tilde{R}_2 \leq \mathbb{H}(U_0, V_0|Z), \quad (50)$$

note that [12, Theorem 1] returns a total of 15 inequalities, but the remaining are redundant because of (48)-(50). The above constraints imply that

$$P(z^n, w_{[1:2]}, f_{[1:2]}) \approx p(z^n)p^U(w_{[1:2]})p^U(f_{[1:2]}).$$

Similarly, substituting $X_1 \leftarrow (U_0, U_1)$, $X_2 \leftarrow (U_0, U_2)$, $X_3 \leftarrow (V_0, V_1)$, $X_4 \leftarrow (V_0, V_2)$, and $Z \leftarrow (U_0, V_0, Z)$ in [12, Theorem 1] implies that $(f'_{[1:2]}, f''_{[1:2]})$ are nearly mutually independent and independent of (U_0, V_0, Z) , therefore they are independent of $(w_{[1:2]}, f_{[1:2]})$, if

$$\tilde{R}'_j \leq \mathbb{H}(U_j|U_0, V_0, Z), \quad (51)$$

$$\tilde{R}''_j \leq \mathbb{H}(V_j|U_0, V_0, Z), \quad (52)$$

$$\tilde{R}'_1 + \tilde{R}''_j \leq \mathbb{H}(U_1, V_j|U_0, V_0, Z), \quad (53)$$

$$\tilde{R}'_2 + \tilde{R}''_j \leq \mathbb{H}(U_2, V_j|U_0, V_0, Z), \quad (54)$$

$$\tilde{R}'_1 + \tilde{R}'_2 \leq \mathbb{H}(U_1, U_2|U_0, V_0, Z), \quad (55)$$

$$\tilde{R}''_1 + \tilde{R}''_2 \leq \mathbb{H}(V_1, V_2|U_0, V_0, Z), \quad (56)$$

$$\tilde{R}'_1 + \tilde{R}'_2 + \tilde{R}''_j \leq \mathbb{H}(U_1, U_2, V_j|U_0, V_0, Z), \quad (57)$$

$$\tilde{R}'_j + \tilde{R}''_1 + \tilde{R}''_2 \leq \mathbb{H}(U_j, V_1, V_2|U_0, V_0, Z), \quad (58)$$

$$\tilde{R}'_1 + \tilde{R}'_2 + \tilde{R}''_1 + \tilde{R}''_2 \leq \mathbb{H}(U_1, U_2, V_1, V_2|U_0, V_0, Z), \quad (59)$$

for $j = 1, 2$. The above constraints imply

$$P(z^n, u_0^n, v_0^n, f'_{[1:2]}, f''_{[1:2]}) \approx p(z^n, u_0^n, v_0^n)p^U(f'_{[1:2]})p^U(f''_{[1:2]}). \quad (60)$$

Hence,

$$P(w_{[1:2]}, f_{[1:2]}) = \hat{P}(w_{[1:2]}, f_{[1:2]}) = p^U(w_{[1:2]})p^U(f_{[1:2]}), \quad (61)$$

$$P(f'_{[1:2]}, f''_{[1:2]}|u_0^n, v_0^n) = \hat{P}(f'_{[1:2]}, f''_{[1:2]}|u_0^n, v_0^n) = p^U(f'_{[1:2]})p^U(f''_{[1:2]}). \quad (62)$$

In other words, the inequalities (48)-(50) and (51)-(59) imply that

$$P(z^n, w_{[1:2]}, f_{[1:2]}, f'_{[1:2]}, f''_{[1:2]}) \approx p(z^n)p^U(w_{[1:2]})p^U(f_{[1:2]})p^U(f'_{[1:2]})p^U(f''_{[1:2]}). \quad (63)$$

Here, the pmf $P(z^n)$ is equal to $p(z^n)$ because the marginal distribution does not include random binning.

Therefore, the distributions in (46) and (47) are equal, that is

$$P(u_{[0:2]}^n, v_{[0:2]}^n, y_1^n, y_2^n, z^n, w_{[1:2]}, \mathbf{f}, \hat{\mathbf{u}}) = \hat{P}(u_{[0:2]}^n, v_{[0:2]}^n, y_1^n, y_2^n, z^n, w_{[1:2]}, \mathbf{f}, \hat{\mathbf{u}}). \quad (64)$$

For the Slepian-Wolf decoding of (U_0^n, U_j^n) and (V_0^n, V_j^n) , we use the decodability constraints from [12, Lemma 1] by substituting $X_1 \leftarrow U_0$, $X_2 \leftarrow (U_0, U_j)$, $X_3 \leftarrow V_0$, $X_4 \leftarrow (V_0, V_j)$:

$$\tilde{R}'_j \geq \mathbb{H}(U_j | U_0, V_0, V_j, Y_j), \quad (65)$$

$$\tilde{R}''_j \geq \mathbb{H}(V_j | U_0, U_j, V_0, Y_j), \quad (66)$$

$$\tilde{R}'_j + \tilde{R}''_j \geq \mathbb{H}(U_j, V_j | U_0, V_0, Y_j), \quad (67)$$

$$\tilde{R}_1 + \tilde{R}'_j \geq \mathbb{H}(U_0, U_j | V_0, V_j, Y_j), \quad (68)$$

$$\tilde{R}_2 + \tilde{R}'_j \geq \mathbb{H}(U_j | U_0, V_0, V_j, Y_j), \quad (69)$$

$$\tilde{R}_1 + \tilde{R}''_j \geq \mathbb{H}(V_j | U_0, U_j, V_0, Y_j), \quad (70)$$

$$\tilde{R}_2 + \tilde{R}''_j \geq \mathbb{H}(V_0, V_j | U_0, U_j, Y_j), \quad (71)$$

$$\tilde{R}_1 + \tilde{R}'_j + \tilde{R}''_j \geq \mathbb{H}(U_0, U_j, V_j | V_0, Y_j), \quad (72)$$

$$\tilde{R}_1 + \tilde{R}'_j + \tilde{R}_2 \geq \mathbb{H}(U_0, U_j | V_0, V_j, Y_j), \quad (73)$$

$$\tilde{R}_1 + \tilde{R}''_j + \tilde{R}_2 \geq \mathbb{H}(V_0, V_j | U_0, U_j, Y_j), \quad (74)$$

$$\tilde{R}'_j + \tilde{R}_2 + \tilde{R}''_j \geq \mathbb{H}(U_j, V_0, V_j | U_0, Y_j), \quad (75)$$

$$\tilde{R}_1 + \tilde{R}'_j + \tilde{R}_2 + \tilde{R}''_j \geq \mathbb{H}(U_0, U_j, V_0, V_j | Y_j), \quad (76)$$

for $j = 1, 2$. Note that [12, Lemma 1] returns 15 inequalities; we have omitted the ones that are trivially redundant. In addition, inequalities (69), (70), (73), and (74) are redundant because of (65), (66), (68), and (71), respectively. Moreover, inequalities (65), (66), and (67) are superfluous because they refer to rates $\tilde{R}'_j, \tilde{R}''_j$ for codebooks that are not decoded (only participate in indirect decoding of other codebooks). By the same argument (72), and (75) are also superfluous.

$$\begin{aligned} P(u_{[0:2]}^n, v_{[0:2]}^n, y_1^n, y_2^n, z^n, w_{[1:2]}, \mathbf{f}, \hat{\mathbf{u}}) &\approx P(u_{[0:2]}^n, v_{[0:2]}^n, y_1^n, y_2^n, z^n, w_{[1:2]}, \mathbf{f}) \\ &\times \mathbb{1}\{\hat{u}_0^n = \check{u}_0^n = u_0^n, \hat{u}_1^n = u_1^n, \check{u}_2^n = u_2^n\} \mathbb{1}\{\hat{v}_0^n = \check{v}_0^n = v_0^n, \hat{v}_1^n = v_1^n, \check{v}_2^n = v_2^n\}. \end{aligned} \quad (77)$$

From Equations (64), (77), and the triangle inequality,

$$\begin{aligned} \hat{P}(u_{[0:2]}^n, v_{[0:2]}^n, y_1^n, y_2^n, z^n, w_{[1:2]}, \mathbf{f}, \hat{\mathbf{u}}) &\approx P(u_{[0:2]}^n, v_{[0:2]}^n, y_1^n, y_2^n, z^n, w_{[1:2]}, \mathbf{f}) \\ &\times \mathbb{1}\{\hat{u}_0^n = \check{u}_0^n = u_0^n, \hat{u}_1^n = u_1^n, \check{u}_2^n = u_2^n\} \mathbb{1}\{\hat{v}_0^n = \check{v}_0^n = v_0^n, \hat{v}_1^n = v_1^n, \check{v}_2^n = v_2^n\}. \end{aligned} \quad (78)$$

For convenience, we reintroduce a Lemma from [12]:

Lemma 2. (*[12, Lemma 4]*) *Consider distributions $p_{X^n}, p_{Y^n|X^n}, q_{X^n}, q_{Y^n|X^n}$ and random pmfs $P_{X^n}, P_{Y^n|X^n}, Q_{X^n}, Q_{Y^n|X^n}$. Denoting asymptotic equality under total variation with \approx , we have:*

1)

$$P_{X^n} \approx Q_{X^n} \Rightarrow P_{X^n} P_{Y^n|X^n} \approx Q_{X^n} P_{Y^n|X^n} \quad (79)$$

$$P_{X^n} P_{Y^n|X^n} \approx Q_{X^n} Q_{Y^n|X^n} \Rightarrow P_{X^n} \approx Q_{X^n} \quad (80)$$

2) *If $p_{X^n} p_{Y^n|X^n} \approx q_{X^n} q_{Y^n|X^n}$, then there exists a sequence $x^n \in \mathcal{X}^n$ such that*

$$p_{Y^n|X^n=x^n} \approx q_{Y^n|X^n=x^n}. \quad (81)$$

3) *If $P_{X^n} \approx Q_{X^n}$ and $P_{X^n} P_{Y^n|X^n} \approx P_{X^n} Q_{Y^n|X^n}$, then*

$$P_{X^n} P_{Y^n|X^n} \approx Q_{X^n} Q_{Y^n|X^n}. \quad (82)$$

Using Lemma 2, Equation (80), the marginal distributions of the two sides of (78) are asymptotically equivalent, i.e.,

$$\begin{aligned} \hat{P}(u_{[0:2]}^n, v_{[0:2]}^n, z^n, w_{[1:2]}, \mathbf{f}, \hat{\mathbf{u}}) &\approx P(u_{[0:2]}^n, v_{[0:2]}^n, z^n, w_{[1:2]}, \mathbf{f}) \\ &\times \mathbb{1}\{\hat{u}_0^n = \check{u}_0^n = u_0^n, \hat{u}_1^n = u_1^n, \check{u}_2^n = u_2^n\} \mathbb{1}\{\hat{v}_0^n = \check{v}_0^n = v_0^n, \hat{v}_1^n = v_1^n, \check{v}_2^n = v_2^n\}. \end{aligned} \quad (83)$$

Using Lemma 2, Equation (79) we multiply the two sides of Equation (83) by the conditional distribution:

$$\begin{aligned} \hat{P}(\hat{w}_1, \check{w}_1, \hat{w}_2, \check{w}_2 | u_{[0:2]}^n, v_{[0:2]}^n, z^n, w_{[1:2]}, \mathbf{f}, \hat{\mathbf{u}}) = \\ \mathbb{1}\{W_1(\hat{u}_0^n) = \hat{w}_1, W_1(\check{u}_0^n) = \check{w}_1\} \mathbb{1}\{W_2(\hat{v}_0^n) = \hat{w}_2, W_2(\check{v}_0^n) = \check{w}_2\} \end{aligned}$$

to get:

$$\begin{aligned} \hat{P}(u_{[0:2]}^n, v_{[0:2]}^n, z^n, w_{[1:2]}, \mathbf{f}, \hat{\mathbf{u}}, \hat{w}_1, \check{w}_1, \hat{w}_2, \check{w}_2) &\approx P(u_{[0:2]}^n, v_{[0:2]}^n, z^n, w_{[1:2]}, \mathbf{f}) \\ &\times \mathbb{1}\{\hat{u}_0^n = \check{u}_0^n = u_0^n, \hat{u}_1^n = u_1^n, \check{u}_2^n = u_2^n\} \mathbb{1}\{\hat{v}_0^n = \check{v}_0^n = v_0^n, \hat{v}_1^n = v_1^n, \check{v}_2^n = v_2^n\} \\ &\times \mathbb{1}\{W_1(\hat{u}_0^n) = \hat{w}_1, W_1(\check{u}_0^n) = \check{w}_1\} \mathbb{1}\{W_2(\hat{v}_0^n) = \hat{w}_2, W_2(\check{v}_0^n) = \check{w}_2\} \\ &= P(u_{[0:2]}^n, v_{[0:2]}^n, z^n, w_{[1:2]}, \mathbf{f}) \\ &\times \mathbb{1}\{\hat{u}_0^n = \check{u}_0^n = u_0^n, \hat{u}_1^n = u_1^n, \check{u}_2^n = u_2^n\} \mathbb{1}\{\hat{v}_0^n = \check{v}_0^n = v_0^n, \hat{v}_1^n = v_1^n, \check{v}_2^n = v_2^n\} \end{aligned}$$

$$\times \mathbb{1}\{\hat{w}_1 = \check{w}_1 = w_1, \hat{w}_2 = \check{w}_2 = w_2\}, \quad (84)$$

where $W_1(u_0^n) = \hat{w}_1$ and $W_2(v_0^n) = \hat{w}_2$ denote the bins assigned to u_0^n and v_0^n , respectively.

Using (84) and Lemma 2, Equation (79) leads to

$$\hat{P}(z^n, w_{[1:2]}, \mathbf{f}, \hat{w}_1, \check{w}_1, \hat{w}_2, \check{w}_2) \approx P(z^n, w_{[1:2]}, \mathbf{f}) \mathbb{1}\{\hat{w}_1 = \check{w}_1 = w_1, \hat{w}_2 = \check{w}_2 = w_2\}, \quad (85)$$

Using Equations (63) and (85) and Lemma 2, Equation (82) leads to

$$\begin{aligned} & \hat{P}(z^n, w_{[1:2]}, \mathbf{f}, \hat{w}_1, \check{w}_1, \hat{w}_2, \check{w}_2) \\ & \approx p(z^n) p^U(w_{[1:2]}, f_{[1:2]}) p^U(f'_{[1:2]}, f''_{[1:2]}) \mathbb{1}\{\hat{w}_1 = \check{w}_1 = w_1, \hat{w}_2 = \check{w}_2 = w_2\}. \end{aligned} \quad (86)$$

We now eliminate the shared randomness $(F_{[1:2]}, F'_{[1:2]}, F''_{[1:2]})$ without affecting the secrecy and reliability requirements. By using Definition 4, Equation (86) ensures that there is a fixed binning with corresponding pmf p that, if used in place of the random coding strategy P in (47), it will induce the pmf \hat{p} as follows:

$$\begin{aligned} & \hat{p}(z^n, w_{[1:2]}, f_{[1:2]}, f'_{[1:2]}, f''_{[1:2]}, \hat{w}_1, \check{w}_1, \hat{w}_2, \check{w}_2) \\ & \approx p(z^n) p^U(w_{[1:2]}, f_{[1:2]}) p^U(f'_{[1:2]}, f''_{[1:2]}) \mathbb{1}\{\hat{w}_1 = \check{w}_1 = w_1, \hat{w}_2 = \check{w}_2 = w_2\}. \end{aligned} \quad (87)$$

Now, using Lemma 2, Equation (81) shows there exists an instance of $(f_{[1:2]}, f'_{[1:2]}, f''_{[1:2]})$ so that:

$$\begin{aligned} & \hat{p}(z^n, w_{[1:2]}, \hat{w}_1, \check{w}_1, \hat{w}_2, \check{w}_2 | f_{[1:2]}, f'_{[1:2]}, f''_{[1:2]}) \\ & \approx p(z^n) p^U(w_1) p^U(w_2) \mathbb{1}\{\hat{w}_1 = \check{w}_1 = w_1, \hat{w}_2 = \check{w}_2 = w_2\}. \end{aligned} \quad (88)$$

This distribution satisfies the secrecy and reliability requirements as follows:

- Reliability: Using Lemma 2, Equation (80) leads to

$$\hat{p}(w_{[1:2]}, \hat{w}_{1,1}, \hat{w}_{1,2}, \hat{w}_{2,1}, \hat{w}_{2,2} | f_{[1:2]}, f'_{[1:2]}, f''_{[1:2]}) \approx \mathbb{1}\{\hat{w}_1 = \check{w}_1 = w_1, \hat{w}_2 = \check{w}_2 = w_2\}, \quad (89)$$

which is equivalent to:

$$\hat{p}\left(\{(\hat{W}_1, \hat{W}_2) \neq (W_1, W_2)\} \cup \{(\check{W}_1, \check{W}_2) \neq (W_1, W_2)\} \mid f_{[1:2]}, f'_{[1:2]}, f''_{[1:2]}\right) \rightarrow 0.$$

- Security: Again, using Lemma 2, Equation (80)

$$\hat{p}(z^n, w_{[1:2]} | f_{[1:2]}, f'_{[1:2]}, f''_{[1:2]}) \approx p(z^n) p^U(w_1) p^U(w_2). \quad (90)$$

Finally, we identify $p(x_1^n | w_1, f_1, f'_{[1:2]})$ and $p(x_2^n | w_2, f_2, f''_{[1:2]})$ (which is done by generating $u_{[0:2]}$ and $v_{[0:2]}$ first, respectively) as encoders and the Slepian-Wolf decoders as decoders for the

channel coding problem. These encoders and decoders lead to reliable and secure encoder and decoders.

By applying a computer generated Fourier-Motzkin procedure to (48)-(59), (68), (71), and (76) the achievable rate region for the strong secrecy regime in Theorem 6 are obtained [35]. This completes the proof. \square

Remark 5. *If we assume that (14), and therefore (15), holds, the inequalities (53) for $j = 2$, (54) for $j = 1$, and (55)-(59) will be redundant and by applying the Fourier-Motzkin procedure to (48)-(52), (53) for $j = 1$, (54) for $j = 2$, (68), (71), and (76) the region in Theorem 1 over the distribution (41) will be achieved. This shows that the region derived by OSRB is a superset of the region derived in the weak secrecy regime.*

Remark 6. *The random distributions $P(u_0^n, v_0^n | w_{[1:2]}, f_{[1:2]})$ and $P(u_{[1:2]}^n, v_{[1:2]}^n | u_0^n, v_0^n, f'_{[1:2]}, f''_{[1:2]})$ factorize as $P(u_0^n | w_1, f_1)P(v_0^n | w_2, f_2)$ and $P(u_{[1:2]}^n | u_0^n, f'_{[1:2]})P(v_{[1:2]}^n | v_0^n, f''_{[1:2]})$, respectively, which means, Encoders 1, 2 are not using the common randomness and the message available at the other encoder to generate the common and private random variables. The common randomnesses $(F_1, F'_{[1:2]})$ represent the realization of Encoder 1's codebook and $(F_2, F''_{[1:2]})$ represent the realization of Encoder 2's codebook, which is available at all terminals, but the codebook at one encoder does not depend on the codebook of the other encoder.*

Remark 7. *The achievable region described in the proof of Theorem 6 was without time sharing, i.e., $Q = \emptyset$. The convexity of this region is unclear, therefore it might be improved via time sharing.*

APPENDIX A

PROOF OF LEMMA 1

Let $N(Q^n, U_0^n, V_0^n, Z^n) = |\{(k, \ell) \in \llbracket 1, 2^{nS} \rrbracket \times \llbracket 1, 2^{nT} \rrbracket : (Q^n, U_0^n, V_0^n, U_1^n(k), V_1^n(\ell), Z^n) \in \mathcal{T}_\epsilon^{(n)}\}|$. Next, let define the following error events.

Let $E_1(Q^n, U_0^n, V_0^n, Z^n) = 1$ if $N(Q^n, U_0^n, V_0^n, Z^n) \geq (1 + \delta_1(\epsilon))2^{n(S+T-\mathbb{I}(U_1, V_1; Z|Q, U_0, V_0) + \delta(\epsilon))}$ and $E_1 = 0$ otherwise.

Let $E = 0$ if $(Q^n, U_0^n, V_0^n, U_1^n(K), V_1^n(L), Z^n) \in \mathcal{T}_\epsilon^{(n)}$ and $E_1(Q^n, U_0^n, V_0^n, Z^n, K, L) = 0$ and $E = 1$ otherwise.

We now show that if $S \geq \mathbb{I}(U_1; Z|Q, U_0, V_0) + \delta(\epsilon)$, $T \geq \mathbb{I}(V_1; Z|Q, U_0, V_0) + \delta(\epsilon)$, and $S + T \geq \mathbb{I}(U_1, V_1; Z|Q, U_0, V_0) + \delta(\epsilon)$, then $\mathbb{P}(E = 1) \rightarrow 0$ as $n \rightarrow \infty$.

By the union bound we have

$$\mathbb{P}(E = 1) \leq \mathbb{P}((Q^n, U_0^n, V_0^n, U_1^n(K), V_1^n(L), Z^n) \notin \mathcal{T}_\epsilon^{(n)}) + \mathbb{P}(E_1(Q^n, U_0^n, V_0^n, Z^n, K, L) = 1). \quad (91)$$

The first term tends to zero by the main assumption of the Lemma.

We then partition the event $\{E_1 = 1\}$ based on the composition of the typical sequences $(Q^n, U_0^n, V_0^n, U_1^n(k), V_1^n(\ell), Z^n) \in \mathcal{T}_\epsilon^{(n)}$:

- When all such typical sequences share the same $U_1^n(k)$, i.e., correspond to a single k .
- When all such typical sequences share the same $V_1^n(\ell)$, i.e., correspond to a single ℓ .
- Neither of the above

As usual, each of the three partitioned E_1 events gives rise to one rate constraint. We discuss the first in detail; the remaining two follow similarly. Define $A(Q^n, U_0^n, V_0^n, z^n)$ as the event $\{E_1(Q^n, U_0^n, V_0^n, Z^n) = 1\} \cap \{Z^n = z^n\}$,

$$\begin{aligned} & \mathbb{P}(E_1(Q^n, U_0^n, V_0^n, Z^n) = 1) \\ &= \sum_{(q^n, u_0^n, v_0^n) \in \mathcal{T}_\epsilon^{(n)}} p(q^n, u_0^n, v_0^n) \mathbb{P}((E_1(Q^n, U_0^n, V_0^n, Z^n) = 1) | Q^n = q^n, U_0^n = u_0^n, V_0^n = v_0^n) \\ &= \sum_{\substack{(q^n, u_0^n, v_0^n) \in \mathcal{T}_\epsilon^{(n)}(Q, U_0, V_0) \\ z^n \in \mathcal{T}_\epsilon^{(n)}(Z | Q, U_0, V_0)}} p(q^n, u_0^n, v_0^n) \mathbb{P}(A(q^n, u_0^n, v_0^n, z^n) | Q^n = q^n, U_0^n = u_0^n, V_0^n = v_0^n) \\ &\leq \sum_{(q^n, u_0^n, v_0^n) \in \mathcal{T}_\epsilon^{(n)}(Q, U_0, V_0)} p(q^n, u_0^n, v_0^n) \sum_{z^n \in \mathcal{T}_\epsilon^{(n)}(Z | Q, U_0, V_0)} \mathbb{P}((E_1(q^n, u_0^n, v_0^n, z^n) = 1) \\ &\quad | Q^n = q^n, U_0^n = u_0^n, V_0^n = v_0^n). \end{aligned} \quad (92)$$

Then,

$$\begin{aligned} & \mathbb{P}(E_1(q^n, u_0^n, v_0^n, z^n) = 1 | Q^n = q^n, U_0^n = u_0^n, V_0^n = v_0^n) = \\ & \mathbb{P}(N(q^n, u_0^n, v_0^n, z^n) \geq (1 + \delta_1(\epsilon)) 2^{n(T - \mathbb{I}(V_1; Z | Q, U_0, V_0) + \delta(\epsilon))}). \end{aligned} \quad (93)$$

Define $X_\ell = 1$ if $(q^n, u_0^n, v_0^n, V_1^n(\ell), z^n) \in \mathcal{T}_\epsilon^{(n)}$ and 0 otherwise. Here, X_ℓ , $\ell \in \llbracket 1, 2^{nT} \rrbracket$, are i.i.d. Bernoulli- α random variables, where

$$2^{-n(\mathbb{I}(V_1; Z | Q, U_0, V_0) + \delta(\epsilon))} \leq \alpha \leq 2^{-n(\mathbb{I}(V_1; Z | Q, U_0, V_0) - \delta(\epsilon))}$$

Then

$$\mathbb{P}\left(N(q^n, u_0^n, v_0^n, z^n) \geq (1 + \delta_1(\epsilon)) 2^{n(T - \mathbb{I}(V_1; Z | Q, U_0, V_0) + \delta(\epsilon))} \middle| Q^n = q^n, U_0^n = u_0^n, V_0^n = v_0^n\right)$$

$$\leq \mathbb{P}\left(\sum_{\ell=1}^{2^{nT}} X_\ell \geq (1 + \delta_1(\epsilon))2^{nT}\alpha \mid Q^n = q^n, U_0^n = u_0^n, V_0^n = v_0^n\right). \quad (94)$$

Applying the Chernoff Bound (e.g., see [37, Appendix B]), leads to

$$\begin{aligned} & \mathbb{P}\left(\sum_{\ell=1}^{2^{nT}} X_\ell \geq (1 + \delta_1(\epsilon))2^{nT}\alpha \mid Q^n = q^n, U_0^n = u_0^n, V_0^n = v_0^n\right) \\ & \leq \exp(-2^{nT}\alpha\delta_1^2(\epsilon)/4) \\ & \leq \exp(-2^{n(T-\mathbb{I}(V_1; Z|Q, U_0, V_0)-\delta(\epsilon))}\delta_1^2(\epsilon)/4). \end{aligned} \quad (95)$$

Therefore,

$$\begin{aligned} & \mathbb{P}(E_1(Q^n, U_0^n, V_0^n, Z^n) = 1) \\ & \leq \sum_{(q^n, u_0^n, v_0^n) \in \mathcal{T}_\epsilon^{(n)}} p(q^n, u_0^n, v_0^n) \sum_{z^n \in \mathcal{T}_\epsilon^{(n)}(Z|Q, U_0, V_0)} \exp(-2^{n(T-\mathbb{I}(V_1; Z|Q, U_0, V_0)-\delta(\epsilon))}\delta_1^2(\epsilon)/4) \\ & \leq 2^{n \log |\mathcal{Z}|} \exp(-2^{n(T-\mathbb{I}(V_1; Z|Q, U_0, V_0)-\delta(\epsilon))}\delta_1^2(\epsilon)/4), \end{aligned} \quad (96)$$

which tends to zero as $n \rightarrow \infty$ if $T \geq \mathbb{I}(V_1; Z|Q, U_0, V_0) + \delta(\epsilon)$.

In a similar manner, the bounding of error probability for the second and third partition of E_1 (please see above) will give rise to the rate constraints $S \geq \mathbb{I}(U_1; Z|Q, U_0, V_0) + \delta(\epsilon)$, and $S + T \geq \mathbb{I}(U_1, V_1; Z|Q, U_0, V_0) + \delta(\epsilon)$, respectively. Details are omitted for brevity.

Finally, we bound $\mathbb{H}(L, K|Q^n, U_0^n, V_0^n, Z^n, C)$ as follows:

$$\begin{aligned} & \mathbb{H}(L, K, E|Q^n, U_0^n, V_0^n, Z^n, C) \\ & \leq 1 + \mathbb{P}(E = 1)\mathbb{H}(L, K|E = 1, Q^n, U_0^n, V_0^n, Z^n, C) + \mathbb{P}(E = 0)\mathbb{H}(L, K|E = 0, Q^n, U_0^n, V_0^n, Z^n, C) \\ & \leq 1 + \mathbb{P}(E = 1)n(S + T) + \log\left((1 + \delta_1(\epsilon))2^{n(S+T-\mathbb{I}(U_1, V_1; Z|Q, U_0, V_0)+\delta(\epsilon))}\right) \\ & \leq n(S + T - \mathbb{I}(U_1, V_1; Z|Q, U_0, V_0) + \delta_2(\epsilon)). \end{aligned} \quad (97)$$

This completes the proof of the Lemma 1.

APPENDIX B

ACHIEVABLE RATE REGION FOR MAC-WTC UNDER RANDOMNESS CONSTRAINT

It is well-known that the transmitter (or transmitters) needs to use a stochastic encoding to avoid the information about the transmitted confidential message to be leaked to an eavesdropper. Here, a new achievability technique for characterizing the trade-off between the rate of the

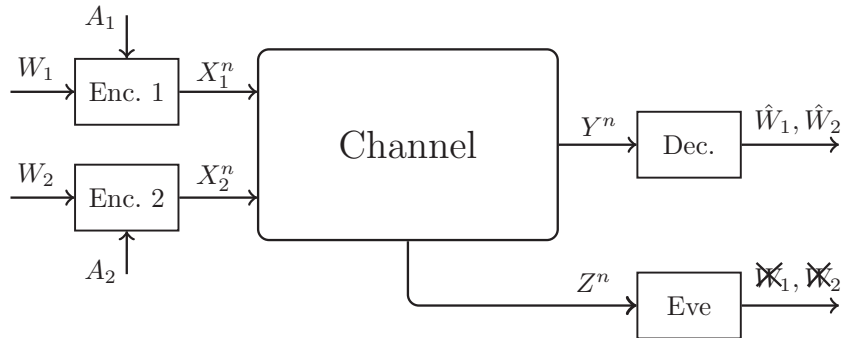

Fig. 7. Multiple access wiretap channel

random number to realize the stochastic encoding and the communication rates in multiple access wiretap channel, by employing a variation of superposition coding, is presented.

Consider a MAC-WTC $(\mathcal{X}_1, \mathcal{X}_2, p(y, z|x_1, x_2), \mathcal{Y}, \mathcal{Z})$, in which $\mathcal{X}_1, \mathcal{X}_2$ are finite input alphabets and \mathcal{Y} and \mathcal{Z} are finite output alphabets at legitimate receiver and the wiretapper, respectively (as depicted in Fig. 7). In this problem, each transmitter sends a confidential message which is supposed to be decoded by the legitimate receiver and must be kept secret from Eavesdropper. Furthermore, for stochastic encoding, Encoder 1 and Encoder 2 are allowed to use a limited amount of randomness. Thus, we are interested in the trade-off between the rate of randomness, and the rates of confidential messages.

Definition 6. A $(M_{1,n}, M_{2,n}, n)$ code for the considered model (Fig. 7) consists of the following:

- i) Two message sets $\mathcal{W}_i = \llbracket 1, M_{i,n} \rrbracket$, $i = 1, 2$, from which independent messages W_1 and W_2 are drawn uniformly distributed over their respective sets. Also, Two dummy message sets $\mathcal{A}_i = \llbracket 1, M'_{i,n} \rrbracket$, $i = 1, 2$, from which independent dummy messages A_1 and A_2 are drawn uniformly distributed over their respective sets.
- ii) Deterministic encoders $f_{i,n}$, $i = 1, 2$, are defined by function $f_{i,n} : \mathcal{W}_i \times \mathcal{A}_i \rightarrow \mathcal{X}_i^n$.
- iii) A decoding function $\phi : \mathcal{Y}^n \rightarrow \mathcal{W}_1 \times \mathcal{W}_2$ that assigns $(\hat{w}_1, \hat{w}_2) \in \llbracket 1, M_{1,n} \rrbracket \times \llbracket 1, M_{2,n} \rrbracket$ to received sequence y^n .

The probability of error is given by:

$$P_e \triangleq \mathbb{P}(\{(\hat{W}_1, \hat{W}_2) \neq (w_1, w_2)\}). \quad (98)$$

Definition 7 ([31]). A quadruple $(R_1, R_{d_1}, R_2, R_{d_2})$ is said to be achievable under weak secrecy if there exists a sequence of $(M_{1,n}, M_{2,n}, M'_{1,n}, M'_{2,n}, n)$ codes with $M_{1,n} \geq 2^{nR_1}$, $M_{2,n} \geq 2^{nR_2}$, $M'_{1,n} \leq 2^{nR_{d_1}}$, $M'_{2,n} \leq 2^{nR_{d_2}}$, so that $P_e \xrightarrow{n \rightarrow \infty} 0$ and

$$\frac{1}{n} \mathbb{I}(W_1, W_2; Z^n) \xrightarrow{n \rightarrow \infty} 0. \quad (99)$$

Theorem 7. An inner bound on the secrecy capacity region of the multiple access wiretap channel is given by the set of non-negative quadruple $(R_1, R_{d_1}, R_2, R_{d_2})$ such that

$$R_1 \leq \mathbb{I}(U; Y|Q, V) - \mathbb{I}(U; Z|Q), \quad (100)$$

$$R_2 \leq \mathbb{I}(V; Y|Q, U) - \mathbb{I}(V; Z|Q), \quad (101)$$

$$R_1 + R_2 \leq \mathbb{I}(U, V; Y|Q) - \mathbb{I}(U, V; Z|Q), \quad (102)$$

$$R_{d_1} \geq \mathbb{I}(U; Z|Q) + \mathbb{I}(X_1; Z|Q, U, V), \quad (103)$$

$$R_{d_2} \geq \mathbb{I}(V; Z|Q) + \mathbb{I}(X_2; Z|Q, U, V), \quad (104)$$

$$R_{d_1} + R_{d_2} \geq \mathbb{I}(U, V; Z|Q) + \mathbb{I}(X_1, X_2; Z|Q, U, V), \quad (105)$$

for some

$$p(q)p(u|q)p(v|q)p(x_1|u)p(x_2|v)p(y, z|x_1, x_2). \quad (106)$$

Remark 8. By setting $U = X_1$, $V = X_2$, and by taking sufficiently large R_{d_1} and R_{d_2} , the result in Theorem 7 reduces to the achievable rate region of multiple access wiretap channel without common message [22]–[24].

Remark 9. By setting $X_2 = \emptyset$ and $V = \emptyset$ (or $X_1 = \emptyset$ and $U = \emptyset$), the result in Theorem 7 reduces to the capacity rate region of broadcast channel with confidential messages under randomness constraint in [16, Corollary 11].

Proof. Rate Splitting: Divide the dummy message A_1 into independent dummy messages $A_{1,1} \in [1, 2^{nR_{1,1}}]$ and $A_{1,2} \in [1, 2^{nR_{1,2}}]$. Also, divide the dummy message A_2 into independent dummy messages $A_{2,1} \in [1, 2^{nR_{2,1}}]$ and $A_{2,2} \in [1, 2^{nR_{2,2}}]$. Therefore, $R_{d_1} = R_{1,1} + R_{1,2}$ and $R_{d_2} = R_{2,1} + R_{2,2}$.

Codebook Generation: Fix $p(q)$, $p(u|q)$, $p(v|q)$, $p(x_1|u)$, $p(x_2|v)$, and $\epsilon > 0$. Randomly and independently generate a typical sequence q^n according to $p(q^n) = \prod_{i=1}^n p(q_i)$. We suppose that all the terminals know q^n .

- i) Generate $2^{n(R_1+R_{1,1})}$ sequences according to $\prod_{i=1}^n p_{U|Q}(u_i|q_i)$. Then, randomly bin these $2^{n(R_1+R_{1,1})}$ sequences into 2^{nR_1} bins. We index these sequences as $u^n(w_1, a_{1,1})$. For each $(w_1, a_{1,1})$, generate $2^{nR_{1,2}}$ codewords $x_1^n(w_1, a_{1,1}, a_{1,2})$ each according to $\prod_{i=1}^n p_{X_1|U}(x_{1,i}|u_i)$.
- ii) Generate $2^{n(R_2+R_{2,1})}$ sequences according to $\prod_{i=1}^n p_{V|Q}(v_i|q_i)$. Then, randomly bin these $2^{n(R_2+R_{2,1})}$ sequences into 2^{nR_2} bins. We index these sequences as $v^n(w_2, a_{2,1})$. For each $(w_2, a_{2,1})$, generate $2^{nR_{2,2}}$ codewords $x_2^n(w_2, a_{2,1}, a_{2,2})$ each according to $\prod_{i=1}^n p_{X_2|V}(x_{2,i}|v_i)$.

Encoding: To send the message w_1 , the Encoder 1 splits a_1 into $(a_{1,1}, a_{1,2})$, and chooses $u^n(w_1, a_{1,1})$. Then it chooses codeword $x_1^n(w_1, a_{1,1}, a_{1,2})$ and send it over the channel.

To send the message w_2 , the Encoder 2 splits a_2 into $(a_{2,1}, a_{2,2})$, and chooses $v^n(w_2, a_{2,1})$. Then it chooses codeword $x_2^n(w_2, a_{2,1}, a_{2,2})$ and send it over the channel.

Decoding and Error Probability Analysis:

- Decoder decodes (w_1, w_2) by finding a unique pair (w_1, w_2) such that $(q^n, u^n(w_1, a_{1,1}), v^n(w_2, a_{2,1}), y^n) \in \mathcal{T}_\epsilon^{(n)}(p_{U,V,Y})$ for some $(a_{1,1}, a_{2,1})$. The probability of error for Receiver goes to zero as $n \rightarrow \infty$ if we choose [37]

$$R_1 + R_{1,1} \leq \mathbb{I}(U; Y|Q, V) - \epsilon, \quad (107)$$

$$R_2 + R_{2,1} \leq \mathbb{I}(V; Y|Q, U) - \epsilon, \quad (108)$$

$$R_1 + R_{1,1} + R_2 + R_{2,1} \leq \mathbb{I}(U, V; Y|Q) - \epsilon. \quad (109)$$

Equivocation Calculation: We analyze mutual information between (W_1, W_2) and Z^n , averaged over all random codebooks

$$\begin{aligned}
& \mathbb{I}(W_1, W_2; Z^n | Q^n, \mathcal{C}) \\
&= \mathbb{I}(W_1, W_2, A_{1,1}, A_{1,2}, A_{2,1}, A_{2,2}; Z^n | Q^n, \mathcal{C}) - \mathbb{I}(A_{1,1}, A_{1,2}, A_{2,1}, A_{2,2}; Z^n | W_1, W_2, Q^n, \mathcal{C}) \\
&\stackrel{(a)}{=} \mathbb{I}(W_1, W_2, A_{1,1}, A_{1,2}, A_{2,1}, A_{2,2}, X_1^n, X_2^n; Z^n | Q^n, \mathcal{C}) - \mathbb{I}(A_{1,1}, A_{1,2}, A_{2,1}, A_{2,2}; Z^n | W_1, W_2, Q^n, \mathcal{C}) \\
&\stackrel{(b)}{=} \mathbb{I}(X_1^n, X_2^n; Z^n | Q^n, \mathcal{C}) - \mathbb{I}(A_{1,1}, A_{1,2}, A_{2,1}, A_{2,2}; Z^n | W_1, W_2, Q^n, \mathcal{C}) \\
&= \mathbb{I}(X_1^n, X_2^n; Z^n | Q^n, \mathcal{C}) - \mathbb{I}(A_{1,1}, A_{2,1}; Z^n | W_1, W_2, Q^n, \mathcal{C}) \\
&\quad - \mathbb{I}(A_{1,2}, A_{2,2}; Z^n | W_1, W_2, A_{1,1}, A_{1,2}, Q^n, \mathcal{C}) \\
&= \mathbb{I}(X_1^n, X_2^n; Z^n | Q^n, \mathcal{C}) - \mathbb{H}(A_{1,1}, A_{2,1} | W_1, W_2, Q^n, \mathcal{C}) + \mathbb{H}(A_{1,1}, A_{2,1} | W_1, W_2, Z^n, Q^n, \mathcal{C}) \\
&\quad - \mathbb{H}(A_{1,2}, A_{2,2} | W_1, W_2, A_{1,1}, A_{2,1}, Q^n, \mathcal{C}) + \mathbb{H}(A_{1,2}, A_{2,2} | W_1, W_2, A_{1,1}, A_{2,1}, Z^n, Q^n, \mathcal{C})
\end{aligned} \quad (110)$$

where (a) is due to X_1^n and X_2^n are deterministic functions of $(W_1, A_{1,1}, A_{1,2})$ and $(W_2, A_{2,1}, A_{2,2})$, respectively. Also, (b) is due to the fact that, given X_1^n and X_2^n , the indices $W_1, W_2, A_{1,1}, A_{1,2}, A_{2,1}$, and $A_{2,2}$ are uniquely determined.

The first term in (110) is bounded as:

$$\mathbb{I}(X_1^n, X_2^n; Z^n | Q^n, \mathcal{C}) \leq n\mathbb{I}(X_1, X_2; Z | Q) + n\epsilon, \quad (111)$$

where $\epsilon \xrightarrow{n \rightarrow \infty} 0$ similar to [37].

For the second term in (110) we have

$$\mathbb{H}(A_{1,1}, A_{2,1} | W_1, W_2, Q^n, \mathcal{C}) = n(R_{1,1} + R_{2,1}). \quad (112)$$

For the third term, substituting $U_0 \leftarrow Q, V_0 \leftarrow Q, U_1 \leftarrow U$, and $V_1 \leftarrow V$ in Lemma 1 result that if $p((Q^n, U^n(W_1, A_{1,1}), V^n(W_2, A_{2,1}), Z^n) \in \mathcal{T}_\epsilon^{(n)}) \xrightarrow{n \rightarrow \infty} 1$ and

$$R_{1,1} \geq \mathbb{I}(U; Z | Q) + \epsilon, \quad (113)$$

$$R_{2,1} \geq \mathbb{I}(V; Z | Q) + \epsilon, \quad (114)$$

$$R_{1,1} + R_{2,1} \geq \mathbb{I}(U, V; Z | Q) + \epsilon. \quad (115)$$

Then,

$$\mathbb{H}(A_{1,1}, A_{2,1} | W_1, W_2, Z^n, Q^n, \mathcal{C}) \leq n(R_{1,1} + R_{2,1} - \mathbb{I}(U, V; Z | Q) + \epsilon). \quad (116)$$

Here, this condition holds because

$$p((Q^n, U^n(W_1, A_{1,1}), X_1^n(W_1, A_{1,1}, A_{1,2}), V^n(W_2, A_{2,1}), X_2^n(W_2, A_{2,1}, A_{2,2}), Z^n) \in \mathcal{T}_\epsilon^{(n)}) \xrightarrow{n \rightarrow \infty} 1. \quad (117)$$

Now, we bound the fourth term in (110),

$$\mathbb{H}(A_{1,2}, A_{2,2} | W_1, W_2, A_{1,1}, A_{2,1}, Q^n, \mathcal{C}) = n(R_{1,2} + R_{2,2}). \quad (118)$$

Now, we bound the last term in (110) by applying Lemma 1,

$$\mathbb{H}(A_{1,2}, A_{2,2} | W_1, W_2, A_{1,1}, A_{2,1}, Z^n, Q^n, \mathcal{C}) \leq n(R_{1,2} + R_{2,2} - \mathbb{I}(X_1, X_2; Z | Q, U, V) + \epsilon), \quad (119)$$

if (117) holds and

$$R_{1,2} \geq \mathbb{I}(X_1; Z | Q, U, V) + \epsilon, \quad (120)$$

$$R_{2,2} \geq \mathbb{I}(X_2; Z | Q, U, V) + \epsilon, \quad (121)$$

$$R_{1,2} + R_{2,2} \geq \mathbb{I}(X_1, X_2; Z|Q, U, V) + \epsilon. \quad (122)$$

Substituting (111), (112), (116), (118), and (119) into (110) yields

$$\begin{aligned} \mathbb{I}(W_1, W_2; Z^n|Q^n, \mathcal{C}) &\leq n\mathbb{I}(X_1, X_2; Z|Q) - n(R_{1,1} + R_{2,1}) \\ &+ n(R_{1,1} + R_{2,1} - \mathbb{I}(U, V; Z|Q) + \epsilon) - n(R_{1,2} + R_{2,2}) \\ &+ n(R_{1,2} + R_{2,2} - \mathbb{I}(X_1, X_2; Z|Q, U, V) + \epsilon). \end{aligned} \quad (123)$$

Therefore $\mathbb{I}(W_1, W_2; Z^n|Q^n, \mathcal{C}) \leq 2n\epsilon$. By applying the Fourier-Motzkin procedure [35] to (107)-(109), (113)-(115), (120)-(122), $R_{d_1} = R_{1,1} + R_{1,2}$, and $R_{d_2} = R_{2,1} + R_{2,2}$ we obtain the region in Theorem 7. This completes the proof of Theorem 7. \square

APPENDIX C

PROOF OF THEOREM 1

The coding scheme is based on superposition coding, Wyner's random binning [38], Marton coding, and applying indirect decoding [13].

The random code generation is as follows:

Fix $p(q)$, $p(u_0|q)$, $p(u_1, u_2|u_0)$, $p(v_0|q)$, $p(v_1, v_2|v_0)$, $p(x_1|u_0, u_1, u_2)$, $p(x_2|v_0, v_1, v_2)$, $\epsilon_1 < \min\{\epsilon', \epsilon''\}$, and $\epsilon_2 < \min\{\epsilon', \epsilon''\}$.

Codebook Generation: Randomly and independently generate a typical sequence q^n according to $p(q^n) = \prod_{i=1}^n p(q_i)$. We suppose that all the terminals know q^n .

- i) Generate $2^{n\tilde{R}_1}$ codewords $u_0^n(\ell_0)$ each according to $\prod_{i=1}^n p_{U_0|Q}(u_{0,i}|q_i)$. Then, randomly bin the $2^{n\tilde{R}_1}$ codewords into 2^{nR_1} bins, $\mathcal{B}(w_1)$, $w_1 \in \llbracket 1, 2^{nR_1} \rrbracket$. For each ℓ_0 , generate 2^{nT_1} codewords $u_1^n(\ell_0, t_1)$ each according to $\prod_{i=1}^n p_{U_1|U_0}(u_{1,i}|u_{0,i})$. Then, randomly bin the 2^{nT_1} codewords into $2^{nR'_1}$ bins, $\mathcal{B}(\ell_0, \ell_1)$, $\ell_1 \in \llbracket 1, 2^{nR'_1} \rrbracket$. Similarly, for each ℓ_0 , generate 2^{nT_2} codewords $u_2^n(\ell_0, t_2)$ each according to $\prod_{i=1}^n p_{U_2|U_0}(u_{2,i}|u_{0,i})$. Then, randomly bin the 2^{nT_2} codewords into $2^{nR''_1}$ bins, $\mathcal{B}(\ell_0, \ell_2)$, $\ell_2 \in \llbracket 1, 2^{nR''_1} \rrbracket$.
- ii) Similarly, generate $2^{n\tilde{R}_2}$ codewords $v_0^n(\ell'_0)$ each according to $\prod_{i=1}^n p_{V_0|Q}(v_{0,i}|q_i)$. Then, randomly bin the $2^{n\tilde{R}_2}$ codewords into 2^{nR_2} bins, $\mathcal{B}(w_2)$, $w_2 \in \llbracket 1, 2^{nR_2} \rrbracket$. For each ℓ'_0 , generate 2^{nS_1} codewords $v_1^n(\ell'_0, s_1)$ each according to $\prod_{i=1}^n p_{V_1|V_0}(v_{1,i}|v_{0,i})$. Then, randomly bin the 2^{nS_1} codewords into $2^{nR'_2}$ bins, $\mathcal{B}(\ell'_0, \ell'_1)$, $\ell'_1 \in \llbracket 1, 2^{nR'_2} \rrbracket$. Similarly, for each ℓ'_0 , generate 2^{nS_2} codewords $v_2^n(\ell'_0, s_2)$ each according to $\prod_{i=1}^n p_{V_2|V_0}(v_{2,i}|v_{0,i})$. Then, randomly bin the 2^{nS_2} codewords into $2^{nR''_2}$ bins, $\mathcal{B}(\ell'_0, \ell'_2)$, $\ell'_2 \in \llbracket 1, 2^{nR''_2} \rrbracket$.

Encoding: To send the message w_1 , the encoder f_1 first uniformly chooses index $L_0 \in \mathcal{B}(w_1)$. Then, it uniformly chooses a pair of indices (L_1, L_2) and selects a jointly typical sequence pair $(u_1^n(L_0, t_1(L_0, L_1)), u_2^n(L_0, t_2(L_0, L_1))) \in \mathcal{T}_{\epsilon_1}^{(n)}(U_1, U_2|U_0)$ in the product bin. If the encoder f_1 finds more than one such pair, then it chooses one of them uniformly at random. We have an error if there is no such pair, in which the encoder f_1 uniformly at random chooses $t_1 \in \mathcal{B}(L_0, L_1)$, $t_2 \in \mathcal{B}(L_0, L_2)$. The error probability of the last event approaches to zero as $n \rightarrow \infty$, if [39]

$$R'_1 + R''_1 \leq T_1 + T_2 - \mathbb{I}(U_1; U_2|U_0) - \epsilon_1. \quad (124)$$

Finally, the encoder f_1 generates a sequence X_1^n at random according to $\prod_{i=1}^n p(x_{1,i}|u_{0,i}, u_{1,i}, u_{2,i})$. Encoder 2 proceeds similarly to encode w_2 and sends codeword X_2^n . The probability of not finding a jointly typical sequence pair $(v_1^n(L'_0, s_1(L'_0, L'_1)), v_2^n(L'_0, s_2(L'_0, L'_1))) \in \mathcal{T}_{\epsilon_2}^{(n)}(V_1, V_2|V_0)$ in the product bin approaches to zero as $n \rightarrow \infty$, if [39]

$$R'_2 + R''_2 \leq S_1 + S_2 - \mathbb{I}(V_1; V_2|V_0) - \epsilon_2. \quad (125)$$

Decoding and Error Probability Analysis:

- Receiver 1 decodes (L_0, L'_0) and therefore (w_1, w_2) indirectly by finding a unique pair $(\hat{\ell}_0, \hat{\ell}'_0)$ such that $(q^n, u_0^n(\hat{\ell}_0), u_1^n(\hat{\ell}_0, t_1), v_0^n(\hat{\ell}'_0), v_1^n(\hat{\ell}'_0, s_1), y_1^n) \in \mathcal{T}_{\epsilon'}^{(n)}(U_0, U_1, V_0, V_1, Y_1)$ for some $t_1 \in \llbracket 1, 2^{nT_1} \rrbracket$ and $s_1 \in \llbracket 1, 2^{nS_1} \rrbracket$. The idea of indirect decoding for the situation that there is just one transmitter is shown in Fig. 8. The probability of error for Receiver 1 goes to zero as $n \rightarrow \infty$ if we choose [37]

$$\tilde{R}_1 + T_1 \leq \mathbb{I}(U_0, U_1; Y_1|Q, V_0, V_1) - \epsilon', \quad (126)$$

$$\tilde{R}_2 + S_1 \leq \mathbb{I}(V_0, V_1; Y_1|Q, U_0, U_1) - \epsilon', \quad (127)$$

$$\tilde{R}_1 + T_1 + \tilde{R}_2 + S_1 \leq \mathbb{I}(U_0, U_1, V_0, V_1; Y_1|Q) - \epsilon'. \quad (128)$$

- Similarly Receiver 2 decodes (L_0, L'_0) and therefore (w_1, w_2) indirectly by finding a unique pair $(\check{\ell}_0, \check{\ell}'_0)$ such that $(q^n, u_0^n(\check{\ell}_0), u_2^n(\check{\ell}_0, t_2), v_0^n(\check{\ell}'_0), v_2^n(\check{\ell}'_0, s_2), y_2^n) \in \mathcal{T}_{\epsilon''}^{(n)}(U_0, U_2, V_0, V_2, Y_2)$ for some $t_2 \in \llbracket 1, 2^{nT_2} \rrbracket$ and $s_2 \in \llbracket 1, 2^{nS_2} \rrbracket$. The probability of error for Receiver 1 goes to zero as $n \rightarrow \infty$ if we choose [37]

$$\tilde{R}_1 + T_2 \leq \mathbb{I}(U_0, U_2; Y_2|Q, V_0, V_2) - \epsilon'', \quad (129)$$

$$\tilde{R}_2 + S_2 \leq \mathbb{I}(V_0, V_2; Y_2|Q, U_0, U_2) - \epsilon'', \quad (130)$$

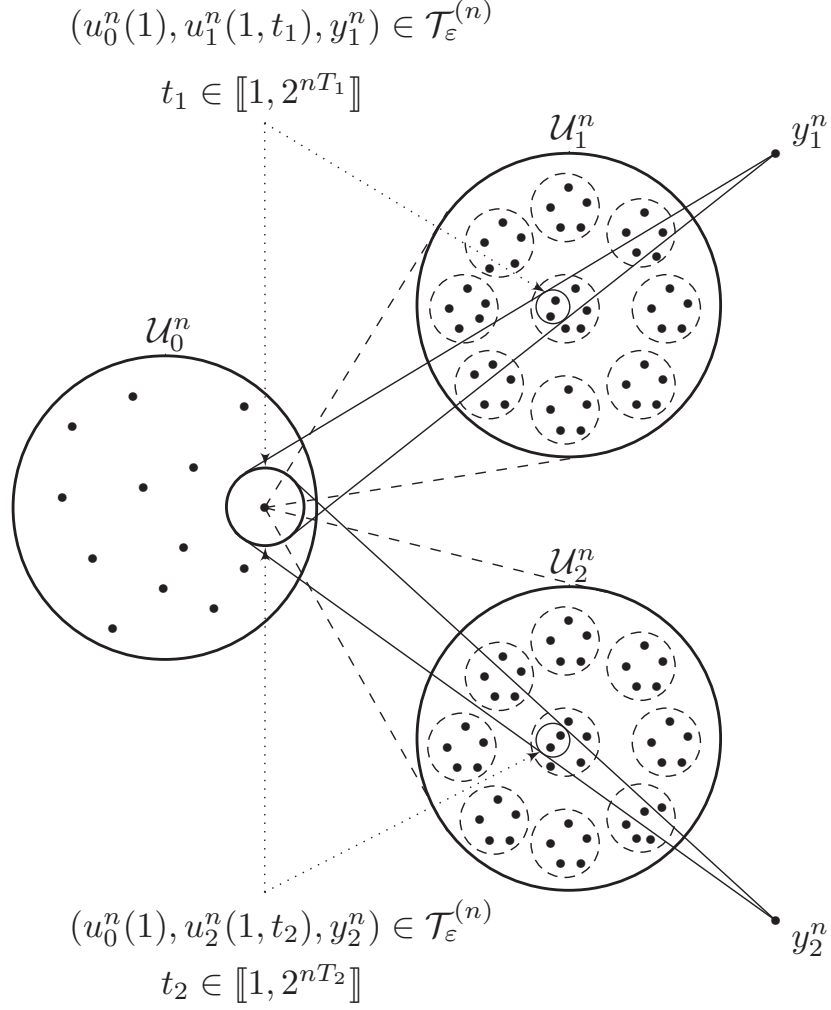

Fig. 8. Indirect decoding for $u_0^n(1)$ via $u_1^n(1, t_1)$ and $u_2^n(1, t_2)$ for the situation that there is just one transmitter.

$$\tilde{R}_1 + T_2 + \tilde{R}_2 + S_2 \leq \mathbb{I}(U_0, U_2, V_0, V_2; Y_2|Q) - \epsilon''. \quad (131)$$

Equivocation Calculation: We analyze mutual information between (W_1, W_2) and Z^n , averaged over all random codebooks

$$\begin{aligned}
& \mathbb{I}(W_1, W_2; Z^n|Q^n, \mathcal{C}) \\
&= \mathbb{I}(W_1, W_2, L_0, T_1, T_2, L'_0, S_1, S_2; Z^n|Q^n, \mathcal{C}) - \mathbb{I}(L_0, T_1, T_2, L'_0, S_1, S_2; Z^n|W_1, W_2, Q^n, \mathcal{C}) \\
&\stackrel{(a)}{\leq} \mathbb{I}(U_0^n, U_1^n, U_2^n, V_0^n, V_1^n, V_2^n; Z^n|Q^n, \mathcal{C}) - \mathbb{I}(L_0, L'_0; Z^n|W_1, W_2, Q^n, \mathcal{C}) \\
&\quad - \mathbb{I}(T_1, T_2, S_1, S_2; Z^n|L_0, L'_0, Q^n, \mathcal{C}) \\
&= \mathbb{I}(U_0^n, U_1^n, U_2^n, V_0^n, V_1^n, V_2^n; Z^n|Q^n, \mathcal{C}) - \mathbb{H}(L_0, L'_0|W_1, W_2, Q^n, \mathcal{C})
\end{aligned}$$

$$+ \mathbb{H}(L_0, L'_0 | Z^n, W_1, W_2, Q^n, \mathcal{C}) - \mathbb{I}(T_1, T_2, S_1, S_2; Z^n | L_0, L'_0, Q^n, \mathcal{C}), \quad (132)$$

where (a) is due to the data processing inequality. Here, T_1 , T_2 , S_1 , and S_2 are deterministic functions of (L_0, L_1) , (L_0, L_2) , (L'_0, L'_1) , and (L'_0, L'_2) , respectively.

The first term in (132) is bounded as:

$$\mathbb{I}(U_0^n, U_1^n, U_2^n, V_0^n, V_1^n, V_2^n; Z^n | Q^n, \mathcal{C}) \leq n\mathbb{I}(U_0, U_1, U_2, V_0, V_1, V_2; Z | Q) + n\epsilon, \quad (133)$$

as $n \rightarrow \infty$ where $\epsilon \rightarrow 0$ similar to [37].

For the second term in (132) we have

$$\mathbb{H}(L_0, L'_0 | W_1, W_2, Q^n, \mathcal{C}) = n(\tilde{R}_1 - R_1 + \tilde{R}_2 - R_2). \quad (134)$$

For the third term, substituting $U_0 = Q$, $V_0 = Q$, $U_1 = U_0$, and $V_1 = V_0$ in Lemma 1 result that. If $p((Q^n, U_0^n(L_0), V_0^n(L'_0), Z^n) \in \mathcal{T}_\epsilon^{(n)}) \rightarrow 1$ as $n \rightarrow \infty$ and $\tilde{R}_1 - R_1 \geq \mathbb{I}(U_0; Z | Q) + \epsilon$, $\tilde{R}_2 - R_2 \geq \mathbb{I}(V_0; Z | Q) + \epsilon$, and $\tilde{R}_1 - R_1 + \tilde{R}_2 - R_2 \geq \mathbb{I}(U_0, V_0; Z | Q) + \epsilon$. Then,

$$\mathbb{H}(L_0, L'_0 | Z^n, W_1, W_2, Q^n, \mathcal{C}) \leq n(\tilde{R}_1 - R_1 + \tilde{R}_2 - R_2 - \mathbb{I}(U_0, V_0; Z | Q) + \epsilon), \quad (135)$$

Here, this condition holds because

$$\begin{aligned} p((Q^n, U_0^n(L_0), U_1^n(L_0, t_1(L_0, L_1)), U_2^n(L_0, t_2(L_0, L_1)), V_0^n(L'_0), V_1^n(L'_0, s_1(L'_0, L'_1)), \\ , V_2^n(L'_0, s_2(L'_0, L'_1)), Z^n) \in \mathcal{T}_\epsilon^{(n)}) \rightarrow 1 \end{aligned} \quad (136)$$

as $n \rightarrow \infty$. Now, we bound the last term in (132)

$$\begin{aligned} & \mathbb{I}(T_1, T_2, S_1, S_2; Z^n | L_0, L'_0, Q^n, \mathcal{C}) \\ &= \mathbb{H}(T_1, T_2, S_1, S_2 | L_0, L'_0, Q^n, \mathcal{C}) - \mathbb{H}(T_1, T_2, S_1, S_2 | Z^n, L_0, L'_0, Q^n, \mathcal{C}) \\ &\stackrel{(a)}{=} \mathbb{H}(T_1, T_2, S_1, S_2, L_1, L_2, L'_1, L'_2 | L_0, L'_0, Q^n, \mathcal{C}) - \mathbb{H}(T_1, T_2, S_1, S_2 | Z^n, L_0, L'_0, Q^n, \mathcal{C}) \\ &\geq \mathbb{H}(L_1, L_2, L'_1, L'_2 | L_0, L'_0, Q^n, \mathcal{C}) - \mathbb{H}(T_1, S_1 | Z^n, L_0, L'_0, Q^n, \mathcal{C}) - \mathbb{H}(T_2, S_2 | Z^n, L_0, L'_0, Q^n, \mathcal{C}) \\ &\stackrel{(b)}{=} \mathbb{H}(L_1, L_2 | L_0, L'_0, Q^n, \mathcal{C}) + \mathbb{H}(L'_1, L'_2 | L_0, L'_0, Q^n, \mathcal{C}) \\ &\quad - \mathbb{H}(T_1, S_1 | Z^n, L_0, L'_0, Q^n, \mathcal{C}) - \mathbb{H}(T_2, S_2 | Z^n, L_0, L'_0, Q^n, \mathcal{C}), \end{aligned} \quad (137)$$

where (a) is due to given the codebook \mathcal{C} and (L_0, L'_0) , (L_1, L_2, L'_1, L'_2) is a deterministic function of $(T_1(L_0, L_1), T_2(L_0, L_2), S_1(L'_0, L'_1), S_2(L'_0, L'_2))$, and (b) holds due to the fact that given $(L_0, L'_0, Q^n, \mathcal{C})$, (L_1, L_2) and (L'_1, L'_2) are independent. Now,

$$\mathbb{H}(L_1, L_2 | L_0, L'_0, Q^n, \mathcal{C}) = n(R'_1 + R''_1), \quad (138)$$

$$\mathbb{H}(L'_1, L'_2 | L_0, L'_0, Q^n, \mathcal{C}) = n(R'_2 + R''_2), \quad (139)$$

$$\mathbb{H}(T_1, S_1 | Z^n, L_0, L'_0, Q^n, \mathcal{C}) \stackrel{(a)}{\leq} n(T_1 + S_1 - \mathbb{I}(U_1, V_1; Z | Q, U_0, V_0) + \epsilon), \quad (140)$$

$$\mathbb{H}(T_2, S_2 | Z^n, L_0, L'_0, Q^n, \mathcal{C}) \stackrel{(b)}{\leq} n(T_2 + S_2 - \mathbb{I}(U_2, V_2; Z | Q, U_0, V_0) + \epsilon), \quad (141)$$

where (a) is due to the following. Consider,

$$\begin{aligned} \mathbb{H}(T_1, S_1 | Z^n, L_0, L'_0, Q^n, \mathcal{C}) &= \mathbb{H}(T_1, S_1 | U_0^n(L_0), V_0^n(L'_0), Z^n, L_0, L'_0, Q^n, \mathcal{C}) \\ &\leq \mathbb{H}(T_1, S_1 | U_0^n(L_0), V_0^n(L'_0), Z^n, Q^n, \mathcal{C}). \end{aligned}$$

Now we upper bound the term $\mathbb{H}(T_1, S_1 | U_0^n(L_0), V_0^n(L'_0), Z^n, Q^n, \mathcal{C})$. From (136) we have $p((Q^n, U_0^n(L_0), U_1^n(L_0, t_1(L_0, L_1)), V_0^n(L'_0), V_1^n(L'_0, s_1(L'_0, L'_1)), Z^n) \in \mathcal{T}_\epsilon^{(n)}) \rightarrow 1$ as $n \rightarrow \infty$. Applying Lemma 1 leads to,

$$\mathbb{H}(T_1, S_1 | U_0^n(L_0), V_0^n(L'_0), Z^n, Q^n, \mathcal{C}) \leq n(T_1 + S_1 - \mathbb{I}(U_1, V_1; Z | Q, U_0, V_0) + \epsilon), \quad (142)$$

if $T_1 \geq \mathbb{I}(U_1; Z | Q, U_0, V_0) + \epsilon$, $S_1 \geq \mathbb{I}(V_1; Z | Q, U_0, V_0) + \epsilon$, and $T_1 + S_1 \geq \mathbb{I}(U_1, V_1; Z | Q, U_0, V_0) + \epsilon$. By the same argument the inequality (b) holds, if the following inequalities hold,

$$\begin{aligned} T_2 &\geq \mathbb{I}(U_2; Z | Q, U_0, V_0) + \epsilon, \\ S_2 &\geq \mathbb{I}(V_2; Z | Q, U_0, V_0) + \epsilon, \\ T_2 + S_2 &\geq \mathbb{I}(U_2, V_2; Z | Q, U_0, V_0) + \epsilon, \end{aligned}$$

Substituting (138)-(141) into (137) leads to,

$$\begin{aligned} &\mathbb{I}(T_1, T_2, S_1, S_2; Z^n | L_0, L'_0, Q^n, \mathcal{C}) \\ &\geq n(R'_1 + R''_1) + n(R'_2 + R''_2) - n(T_1 + S_1 - \mathbb{I}(U_1, V_1; Z | Q, U_0, V_0) + \epsilon) \\ &\quad - n(T_2 + S_2 - \mathbb{I}(U_2, V_2; Z | Q, U_0, V_0) + \epsilon). \end{aligned} \quad (143)$$

Substituting (133)-(135) and (143) into (132) yields

$$\begin{aligned} \mathbb{I}(W_1, W_2; Z^n | Q^n, \mathcal{C}) &\leq n\mathbb{I}(U_0, U_1, U_2, V_0, V_1, V_2; Z | Q) - n(\tilde{R}_1 - R_1 + \tilde{R}_2 - R_2) \\ &\quad + n(\tilde{R}_1 - R_1 + \tilde{R}_2 - R_2 - \mathbb{I}(U_0, V_0; Z | Q)) - n(R'_1 + R''_1) - n(R'_2 + R''_2) \\ &\quad + n(T_1 + S_1 - \mathbb{I}(U_1, V_1; Z | Q, U_0, V_0) + \epsilon) + n(T_2 + S_2 - \mathbb{I}(U_2, V_2; Z | Q, U_0, V_0) + \epsilon). \end{aligned} \quad (144)$$

Therefore $\mathbb{I}(W_1, W_2; Z^n | Q^n, \mathcal{C}) \leq n\epsilon$ if

$$\mathbb{I}(U_1, U_2, V_1, V_2; Z | U_0, V_0) - R'_1 - R''_1 - R'_2 - R''_2 + T_1 + S_1 - \mathbb{I}(U_1, V_1; Z | Q, U_0, V_0)$$

$$+ T_2 + S_2 - \mathbb{I}(U_2, V_2; Z|Q, U_0, V_0) \leq \epsilon. \quad (145)$$

As a result, the rate constraints derived in equivocation analysis are

$$\tilde{R}_1 - R_1 + \tilde{R}_2 - R_2 \geq \mathbb{I}(U_0, V_0; Z|Q), \quad (146)$$

$$\tilde{R}_1 - R_1 \geq \mathbb{I}(U_0; Z|Q), \quad (147)$$

$$\tilde{R}_2 - R_2 \geq \mathbb{I}(V_0; Z|Q), \quad (148)$$

$$T_1 + S_1 \geq \mathbb{I}(U_1, V_1; Z|Q, U_0, V_0), \quad (149)$$

$$T_1 \geq \mathbb{I}(U_1; Z|Q, U_0, V_0), \quad (150)$$

$$S_1 \geq \mathbb{I}(V_1; Z|Q, U_0, V_0), \quad (151)$$

$$T_2 + S_2 \geq \mathbb{I}(U_2, V_2; Z|Q, U_0, V_0), \quad (152)$$

$$T_2 \geq \mathbb{I}(U_2; Z|Q, U_0, V_0), \quad (153)$$

$$S_2 \geq \mathbb{I}(V_2; Z|Q, U_0, V_0), \quad (154)$$

$$\begin{aligned} T_1 + S_1 + T_2 + S_2 - R'_1 - R''_1 - R'_2 - R''_2 &\leq \mathbb{I}(U_1, V_1; Z|Q, U_0, V_0) + \mathbb{I}(U_2, V_2; Z|Q, U_0, V_0) \\ &\quad - \mathbb{I}(U_1, U_2, V_1, V_2; Z|U_0, V_0). \end{aligned} \quad (155)$$

Finally, by applying the Fourier-Motzkin procedure [35] to (124)-(131) and (146)-(155) we obtain the inequalities in Theorem 1. This completes the proof of Theorem 1.

ACKNOWLEDGMENT

The authors would like to thank anonymous reviewers of ISIT 2018 for their helpful comments.

REFERENCES

- [1] R. Ahlswede, "The capacity region of a channel with two senders and two receivers," *Ann. Probab.*, vol. 2, no. 5, pp. 805–814, 1974.
- [2] S. Verdú, "Fifty years of Shannon theory," *IEEE Trans. Inf. Theory*, vol. 44, no. 6, pp. 2057–2078, Oct. 1998.
- [3] T. S. Han and K. Kobayashi, "A new achievable rate region for the interference channel," *IEEE Trans. Inf. Theory*, vol. 27, no. 1, pp. 49–60, Jan. 1981.
- [4] A. Cohen, A. Cohen, M. Médard, and O. Gurewitz, "Secure multi-source multicast," *available at <https://arxiv.org/abs/1702.03012>*, Nov. 2017.
- [5] O. Tervo, L.-M. Tran, H. Pennanen, S. Chatzinotas, B. Ottersten, and M. Juntti, "Energy-efficient multi-cell multigroup multicasting with joint beamforming and antenna selection," *available at <https://arxiv.org/abs/1808.00852>*, Aug. 2018.

- [6] Y. Liang, G. Kramer, H. V. Poor, and S. Shamai, "Compound wiretap channels," in *Proc. 45th Annual Allerton Conference on Communication, Control, and Computing*, Monticello, IL, Sep. 2007, pp. 136–143.
- [7] U. Maurer, *Communications and Cryptography: Two Sides of One Tapestry*. Kluwer Academic Publishers, 1994, ch. The Strong Secret Key Rate of Discrete Random Triples, pp. 271–285.
- [8] M. Bellare, S. Tessaro, and A. Vardy, "Semantic security for the wiretap channel," in *Advances in Cryptology & CRYPTO 2012*, ser. Lecture Notes in Computer Science, R. Safavi-Naini and R. Canetti, Eds., vol. 7417. Springer Berlin Heidelberg, 2012, pp. 294–311, hard-copy.
- [9] M. Hayashi, "General nonasymptotic and asymptotic formulas in channel resolvability and identification capacity and their application to the wiretap channel," *IEEE Trans. Inf. Theory*, vol. 52, no. 4, pp. 1562–1575, Apr. 2006.
- [10] M. R. Bloch and J. N. Laneman, "Strong secrecy from channel resolvability," *IEEE Trans. Inf. Theory*, vol. 59, no. 12, pp. 8077–8098, Dec. 2013.
- [11] Z. Goldfeld, P. Cuff, and H. Permuter, "Semantic-security capacity for wiretap channels of type II," *IEEE Trans. Inf. Theory*, vol. 62, no. 7, pp. 3863–3879, Jul. 2016.
- [12] M. H. Yassaee, M. R. Aref, and A. A. Gohari, "Achievability proof via output statistics of random binning," *IEEE Trans. Inf. Theory*, vol. 60, no. 11, pp. 6786–6760, Nov. 2014.
- [13] Y. K. Chia and A. El Gamal, "Three-receiver broadcast channel with common and confidential messages," *IEEE Trans. Inf. Theory*, vol. 58, no. 9, pp. 2748–2765, May 2012.
- [14] C. Nair and A. El Gamal, "The capacity region of a class of three-receiver broadcast channels with degraded message sets," *IEEE Trans. Inf. Theory*, vol. 55, no. 10, pp. 4479–4493, Oct. 2009.
- [15] J. M. Renes and R. Renner, "Noisy channel coding via privacy amplification and information reconciliation," *IEEE Trans. Inf. Theory*, vol. 57, no. 11, pp. 7377–7385, Nov. 2011.
- [16] S. Watanabe and Y. Oohama, "The optimal use of rate-limited randomness in broadcast channels with confidential messages," *IEEE Trans. Inf. Theory*, vol. 61, no. 2, pp. 983–995, Feb 2015.
- [17] H. ZivariFard, M. R. Bloch, and A. Nosratinia, "Two-transmitter two-receiver channel with confidential messages," in *Proc. 55th Annual Allerton Conference on Communication, Control, and Computing*, Monticello, IL, Sep. 2017, pp. 103–110.
- [18] S. Salehkalaibar, M. Mirmohseni, and M. R. Aref, "One-receiver two-eavesdropper broadcast channel with degraded message sets," *IEEE Trans. Inf. Forensics Security*, vol. 8, no. 12, pp. 1961–1974, Dec. 2013.
- [19] E. Ekrem and S. Ulukus, "Multi-receiver wiretap channel with public and confidential messages," *IEEE Trans. Inf. Theory*, vol. 59, no. 4, pp. 2165–2177, Apr. 2013.
- [20] M. Benammar and P. Piantanida, "Secrecy capacity region of some classes of wiretap broadcast channels," *IEEE Trans. Inf. Theory*, vol. 61, no. 10, pp. 5564–5582, Oct. 2015.
- [21] L. Liang and H. V. Poor, "Multiple-access channels with confidential messages," *IEEE Trans. Inf. Theory*, vol. 3, no. 3, pp. 976–1002, Mar. 2008.
- [22] E. Tekin and A. Yener, "The Gaussian multiple access wire-tap channel," *IEEE Trans. Inf. Theory*, vol. 54, no. 12, pp. 5747–5755, Dec. 2008.
- [23] —, "The general Gaussian multiple-access and two-way wiretap channels: Achievable rates and cooperative jamming," *IEEE Trans. Inf. Theory*, vol. 54, no. 6, pp. 2735–2751, Jun. 2008.
- [24] M. H. Yassaee and M. R. Aref, "Multiple access wiretap channels with strong secrecy," in *Proc. IEEE Info. Theory Workshop (ITW)*, Dublin, Ireland, Sep. 2010, pp. 1–5.
- [25] M. Wiese and H. Boche, "Strong secrecy for multiple access channels," in *Information Theory, Combinatorics, and Search Theory*, Springer, 2013, pp. 71–122.

- [26] A. J. Pierrot and M. R. Bloch, “Strongly secure communications over the two-way wiretap channel,” *IEEE Trans. Inf. Forensics Security*, vol. 6, no. 3, pp. 595–605, Sep. 2011.
- [27] H. Zivari-Fard, B. Akhbari, M. Ahmadian-Attari, and M. R. Aref, “Imperfect and perfect secrecy in compound multiple access channel with confidential message,” *IEEE Trans. Inf. Forensics Security*, vol. 11, no. 6, pp. 1239–1251, Jun. 2016.
- [28] A. Carleial, “Multiple-access channels with different generalized feedback signals,” *IEEE Trans. Inf. Theory*, vol. 28, no. 6, pp. 841–850, Nov. 1982.
- [29] R. Liu, I. Marić, P. Spasojević, and R. D. Yates, “Discrete memoryless interference and broadcast channels with confidential messages,” *IEEE Trans. Inf. Theory*, vol. 54, no. 6, pp. 2493–2507, Jun. 2008.
- [30] P. Cuff, “Distributed channel synthesis,” *IEEE Trans. Inf. Theory*, vol. 59, no. 11, pp. 7071–7096, Nov. 2013.
- [31] M. R. Bloch and J. Barros, *Physical-Layer Security: From Information Theory to Security Engineering*, 1st ed. Cambridge, U.K: Cambridge University Press, 2011.
- [32] Y. Liang, H. V. Poor, and S. Shamai, *Information Theoretic Security*, 1st ed. Hanover, MA, USA: Now Publishers Inc., 2009.
- [33] I. Csiszár and J. Körner, “Broadcast channels with confidential messages,” *IEEE Trans. Inf. Theory*, vol. 24, no. 3, pp. 339–348, May 1978.
- [34] I. Csiszár and J. Körner, “Broadcast channels with confidential messages,” *IEEE Trans. Inf. Theory*, vol. 24, no. 3, pp. 339–348, May 1978.
- [35] I. B. Gattegno, Z. Goldfeld, and H. H. Permuter, “Fourier-Motzkin elimination software for information theoretic inequalities,” in <http://www.ee.bgu.ac.il/~fmeit/>, 2016.
- [36] I. Csiszár, “Almost independence and secrecy capacity,” *IEEE Trans. Inf. Theory*, vol. 32, no. 1, pp. 40–47, Jan. 1996.
- [37] A. El Gamal and Y.-H. Kim, *Network Information Theory*, 1st ed. Cambridge, U.K: Cambridge University Press, 2012.
- [38] A. D. Wyner, “The wire-tap channel,” *Bell System Technical Journal*, vol. 57, no. 8, pp. 1355–1367, Oct. 1975.
- [39] A. El Gamal and E. C. van der Meulen, “A proof of Marton’s coding theorem for the discrete memoryless broadcast channel,” *IEEE Trans. Inf. Theory*, vol. 27, no. 1, pp. 120–122, Jan. 1981.