

Cooperative coevolution of real predator robots and virtual robots in the pursuit domain[☆]

Lijun Sun^a, Chao Lyu^a, Yuhui Shi^{a,*}

^a*Shenzhen Key Laboratory of Computational Intelligence, Department of Computer Science and Engineering, Southern University of Science and Technology, China*

Abstract

The pursuit domain, or predator-prey problem is a standard testbed for the study of coordination techniques. In spite that its problem setup is apparently simple, it is challenging for the research of the emerged swarm intelligence. This paper presents a particle swarm optimization (PSO) based cooperative coevolutionary algorithm for the predator robots, called CCPSO-R, where real and virtual robots coexist for the first time in an evolutionary algorithm (EA). Virtual robots sample and explore the vicinity of the corresponding real robot and act as their action spaces, while the real robots consist of the real predators swarm who actually pursue the prey robot without fixed behavior rules under the immediate guidance of the fitness function, which is designed in a modular manner with very limited domain knowledges. In addition, kinematic limits and collision avoidance considerations are integrated into the update rules of robots. Experiments are conducted on a scalable predator robots swarm with 4 types of preys, the statistical results of which show the reliability, generality, and scalability of the proposed CCPSO-R. Finally, the codes of this paper are public available at: https://github.com/LijunSun90/pursuitCCPSO_R.

[☆]This work is partially supported by National Key R&D Program of China under the Grant No. 2017YFC0804002, National Science Foundation of China under the Grant No. 61761136008, Science and Technology Innovation Committee Foundation of Shenzhen under the Grant No. ZDSYS201703031748284, Shenzhen Peacock Plan under the Grant No. KQTD2016112514355531, Program for Guangdong Introducing Innovative and Entrepreneurial Teams under the Grant No. 2017ZT07X386.

*Corresponding author: Yuhui Shi.

Email addresses: sunlijun522@126.com (Lijun Sun), 11849557@mail.sustc.edu.cn (Chao Lyu), shiyh@sustc.edu.cn (Yuhui Shi)

Keywords: Swarm intelligence, Cooperative coevolution, Particle swarm optimization, Pursuit domain, Virtual robot

1. Introduction

The pursuit domain, or predator-prey problem is a classical and interesting research domain which acts as one of the widely used fundamental testbeds for coordination techniques since it was proposed by Benda et al. [1]. On one hand, its apparently simple problem setup and flexibility in approaches or concept evaluations lead to both its popular and the toy domain impression. On the other hand, it is challenging and thus a good domain for the research of swarm intelligence emerged from the cooperations among robots or agents, which has drawn much attention of researchers on various versions of the pursuit domain.

At first, greedy coordination strategies were manually designed by Korf [2], part of which were improved by Haynes et al. [3]. After that, Haynes et al. [3–6] tried to improve the pursuit performance using evolutionary algorithms, such as genetic programming (GP) [7], strongly typed genetic programming (STGP) [8], and cases learning methods successively. In addition, Undeger and Polat [9] treated the multi-agent dynamic pursuing problem in partially observable environments with obstacles as the dynamic path planning and task allocation problem, and proposed the multi-agent real-time pursuit (MAPS) algorithm. Besides, much works have been done in the field of reinforcement learning (RL). For example, Ishiwaka et al. [10] investigated the mechanism for the emergence of the predators' cooperative behaviors aiming to capture the prey in the continuous world. Barrett et al. [11, 12] evaluated the designed ad hoc teamwork performance in the pursuit domain as one benchmark task. As researches going on, the capture reliability and the efficiency of approaches have both been improved. Finally, a detailed survey on the pursuit domain was given by Stone and Veloso [13].

In this paper, we deal with the dynamic pursuit domain problem with a scal-

able predator robots and types of the prey in bounded diagonal grid worlds. Different from prior work, this paper treats the pursuit domain as an optimization problem and proposes a particle swarm optimization (PSO) based cooperative coevolutionary (CC) algorithm, called CCPSO-R (R is for robots), where, to the best knowledge of authors, real and virtual robots coexist for the first time in an evolutionary algorithm (EA). In detail, we have n subpopulations, each of which evolves independently with the same population size. The first individual of each subpopulation always corresponds to a unique real robot, which consists of the cooperative real predator robots swarm pursuing the prey. The rest are virtual robots, which are always deployed around the corresponding real robot, exploring the real robot’s vicinity in order to guide the real robot to a more advantageous position under the supervision of the fitness function defined on the pursuit task. Hence, in the view of the multiagent system (MAS), these virtual robots can be seen as the action space for each real robot. Since the number of the virtual robots is less than the vicinity size of of a real predator, the exploration of virtual robots is actually a sampling rather than an exhausted vicinity exploration, which is guided by a proven efficiency swarm intelligence algorithm – PSO. Therefore, the proposed CCPSO-R can be expected to be more efficient and effective.

In addition, the collision consideration among real robots is integrated into the fitness function design, which not only separates the robotic considerations from the EAs itself and is thus different from the robotic PSO (RPSO) [14] – the PSO variant specially designed for robots, but also enhances the flexibility of the fitness function by modular design.

Furthermore, unlike previous incrementally constructed EA based methods and RL algorithms, the proposed CCPSO-R is actually an on-line algorithm which plans one step ahead for each robot and can reliably capture the prey even without the training and learning stage under the immediate guidances of the fitness function. Meanwhile, similar to the common strategy in RL algorithms, the prey robot and the rest predator robots (agents in MAS) are treated as parts of the dynamic environment to the current robot without any central

commander/controller.

The rest of the paper is organized as follows. First, the pursuit domain definition and details adopted here are explained in Section 2. Then the proposed CCPSO-R is described in Section 3. Experiments, corresponding results and discussions are presented in Section 4. Finally, conclusions and directions for future researches are contained in Section 5.

2. The pursuit / predator-prey domain

Generally speaking, the pursuit domain problem is a game where predators try to capture the prey with or without coordination. However, as summarized in [13] and mentioned above, the pursuit domain has various versions depending on different combinations of its parameters, such as the type and size of the world, definition of the capture, team size, legal moves and move orders for the predators and prey, distance metric, etc. In many researches, a toroidal world, where a robot comes out of one edge and comes in immediately from the opposite edge, is selected to simulate an infinite world. However, this kind of world is not practical. As depicted in Figure 1a, if the red pentagram is a linear prey which moves in a straight line towards north and just escapes the nearly encirclement of the predators (blue squares), which have the same speed as the prey, in the real infinite world, the predators will never catch the prey in such a situation. But in the toroidal world, if the predators move as shown in Figure 1b, they will capture the linear prey in the next step. Therefore, in this paper, rather than toroidal worlds, bounded grid worlds are selected, which can at least represent part, although not all, of the real world scenarios, such as an indoor room or an outdoor park with boundaries, etc.

Besides, as classified by Korf [2], the game with a discrete world (grid world here) that only allows horizontal and vertical, totally 4 directions movements, is called the orthogonal game, while the one which allows the horizontal, vertical and diagonal 8 directions move is called the diagonal game. Again, towards real applications, the diagonal game is more realistic [2] and thus one of the as-

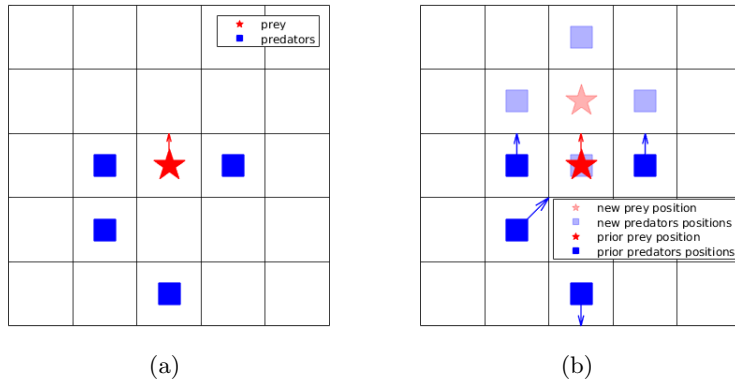

Figure 1: One trick of the coordination strategy in a toroidal world.

sumptions of this paper. In particular, no collisions are allowed and orthogonal obstacles will be considered when the real (predator or prey) robot moves diagonally, as illustrated in Figure 2. Under these assumptions, the capture can be defined as that each of all the available orthogonal neighbors of the prey robot has been occupied by a predator robot as shown in Figure 3. This may be different from the definitions of some research work, especially the RL algorithms or path planning based methods, such as [9], where the capture is defined as that the position of the prey is occupied by a predator.

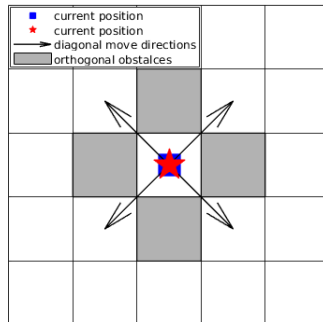

Figure 2: Illustration of the orthogonal obstacles.

As for the other details of the pursuit game, the prey robot always moves first and then the predator robots move one by one in a fixed order, the natural priorities of which can make the collision avoidance control easier and more

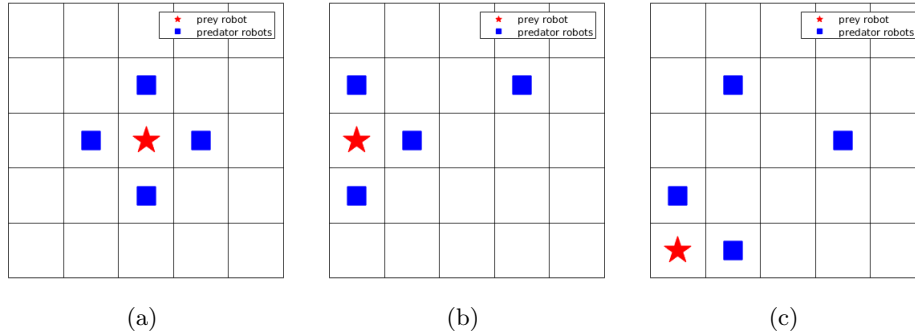

Figure 3: Illustration of the capture, taking 4 predator robots as an example.

reliable. Besides, the position of any real (prey or predator) robot is visible to all the other real (prey or predator) robots, but there is no explicit communications, i.e. no explicit negotiations or coordinations, among the real predator robots. In another word, the coordination among real predator robots, or subpopulations, are implicit here. In addition, as will be seen later, no fixed behavior rules for the predator robots exist due to the fact that the evolution, or the one step ahead plan, of a predator robot in the dynamic environment is only guided by the fitness function.

3. Cooperative coevolution of real and virtual robots

3.1. Fitness function

Since the task is to encircle a prey robot using a swarm of predator robots, the fitness function should subject to the following metrics:

- *CLOSURE*: the prey robot should locate inside the convex hull of the predator robots' positions;
- *SWARM EXPANSE*: the predator robots swarm should concentrate around the prey robot, i.e., a smaller swarm expanse of the predator robots is preferred;
- *UNIFORMITY*: the predator robots should distribute uniformly around the prey robot;

- *COLLISION AVOIDANCE*: collisions among predator robots and prey-predator robots are not allowed in the practical sense.

It is obvious that a single predator robot itself cannot form a solution to the task. In CCPSO-R, a complete solution to the pursuit problem is composed by the positions of all the predator robots. So, the fitness function can be formulated as follows.

Definition of Convex Hull [15]: The *convex hull* of the point set P , denoted by $\text{conv}(P)$, is the intersection of all convex regions that contain P .

Further, we define the function:

$$\text{inconv}(p, \text{conv}(P)) \stackrel{\text{def}}{=} \begin{cases} 0, & \text{if point } p \text{ is in } \text{conv}(P) \\ 0.5, & \text{if point } p \text{ is on the edge of } \text{conv}(P) \\ 1, & \text{if point } p \text{ is outside of } \text{conv}(P) \end{cases} \quad (1)$$

Hence, the fitness function for the j th ($j = 1, \dots, N_p$) individual (robot) in the i th ($i = 1, \dots, N_s$) subpopulation p_{robots}^{ij} is

$$f^{ij} = f_{repel}^{ij} \cdot (f_{closure}^{ij} + f_{expand}^{ij} + f_{uniformity}^{ij}) \quad (2)$$

where

$$f_{repel}^{ij} = \begin{cases} e^{-2 \cdot (NND^{ij} - D_{min})}, & \text{if } NND^{ij} < D_{min} \\ 1, & \text{else} \end{cases} \quad (3)$$

$$f_{closure}^{ij} = \text{inconv}(p_{prey}, \text{conv}(p_{robots}^{11}, \dots, p_{robots}^{ij}, \dots, p_{robots}^{N_s 1})) \quad (4)$$

$$f_{expand}^{ij} = \frac{1}{N_s} \left(\sum_{k=1, k \neq i}^{N_s} |p_{robots}^{k1} - p_{prey}| + |p_{robots}^{ij} - p_{prey}| \right) \quad (5)$$

and

$$f_{uniformity}^{ij} = \text{std} \left(\begin{bmatrix} N_{11} & N_{12} \\ N_{21} & N_{22} \end{bmatrix} \right) \quad (6)$$

in which p_{prey} is the position of the prey robot, NND^{ij} represents the nearest neighbor distance which is the minimum of the pairwise Euclidean distances between the j th individual in the i th subpopulation and all the real predator robots in the other subpopulations, $\text{std}(\cdot)$ stands for the standard deviation

function, and $N_{kh}(k = 1, 2; h = 1, 2)$ is the counts of the real predator robots in the (k, h) -th bin out of the overall 4 bins splitted by the horizontal and vertical lines which intersect at the position of the prey robot, as shown in Figure 4. Note that, the number of the real predator robots on the split lines is divided by 2 and equally assigned to the two adjacent bins. Hence, $N_{11} = N_{12} = N_{21} = N_{22} = 1$ for the example in Figure 4b. However, since the formula (6) cannot always give the right objective uniformity assessment which is consistent with a human's subjective judgement, as the deadlock phenomenon shown in Figure 5a, an alternative space split strategy is performed as shown in Figure 5b, and the following uniformity assessment will replace equation (6) in such situations:

$$f_{uniformity}^{ij} = std([N_{12}, N_{21}, N_{23}, N_{32}]) + std([N_{11}, N_{13}, N_{31}, N_{33}]), \quad (7)$$

the first and second part of which are the axial and diagonal uniformity assessment, respectively.

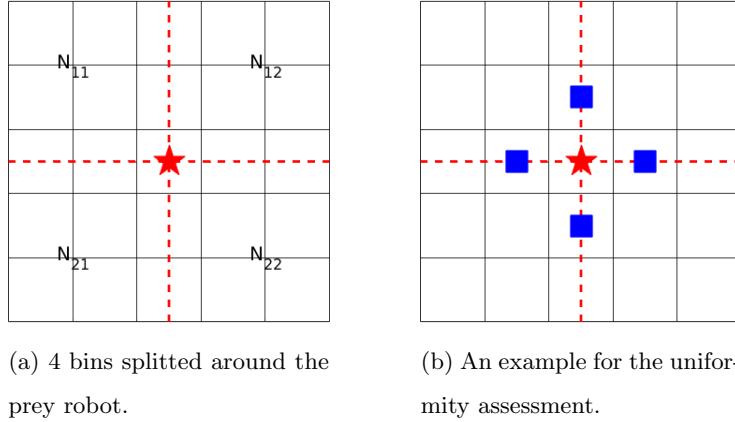
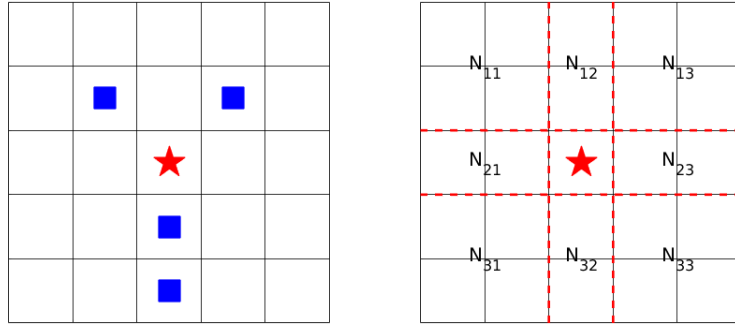

Figure 4: Illustration of the uniformity assessment.

To be more clearer, the fitness evaluation of p_{robots}^{ij} , i.e., the j th ($j = 1, \dots, N_p$) individual (robot) in the i th ($i = 1, \dots, N_s$) subpopulation, is illustrated in Figure 6.



(a) A deadlock attributed to the uniformity assessment by equation (6).

(b) An alternative split method for the uniformity assessment of equation (7).

Figure 5: Illustration of the alternative uniformity assessment.

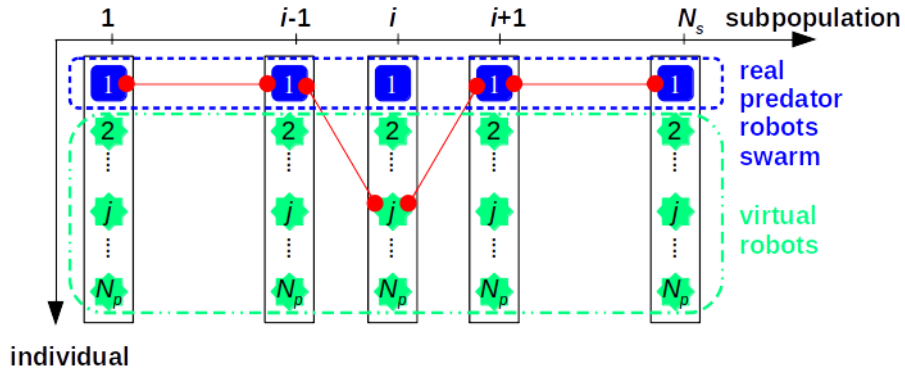

Figure 6: Illustration of the fitness evaluation for p_{robots}^{ij} .

3.2. The proposed CCPSO-R algorithm

In CCPSO-R, there are N_s independently evolved subpopulations with subpopulation size N_p , and the first individual of each subpopulation represents a unique real robot while the others represent virtual robots. All the real robots consist of the predator robots swarm which actually pursue the prey robot in the grid world, while the virtual robots are to explore the vicinity of the corresponding real predator robot in its subpopulation and guide the predator robot to a better position. So in this sense, virtual robots can be seen as the action space of the corresponding real predator robot. The real predator robot chooses its locally optimal action, but in terms of the global benefit of the whole predators swarm. That is, the evaluation of the position of a robot is conducted by considering the positions of the rest real predator robots in the other subpopulations. Since the proposed algorithm works as the modes of cooperative coevolutionary algorithms (CCEAs), it is called the cooperative coevolutionary PSO for robots (CCPSO-R), as illustrated in Algorithm 1.

3.2.1. Update rule

Two update rules are designed separately for virtual and real robots:

1. For a virtual robot j ($j \in \{2, \dots, N_p\}$), the PSO update rules are as follows:

$$\begin{aligned} v_{robots}^{ij} &= nnd(w \cdot v_{robots}^{ij} + c_1 \cdot r_1 \cdot (p_{robots}^{ij} - p_{robots}^{ij}) \\ &\quad + c_2 \cdot r_2 \cdot (pg_{robots}^i - p_{robots}^{ij})) \end{aligned} \quad (8)$$

$$p_{robots}^{ij} = nbn((p_{robots}^{ij} + v_{robots}^{ij}), p_{robots}^{i1}) \quad (9)$$

where

$$nnd(v) = \arg \min_{p_n \in SN} |\angle p_n - \angle v| \quad (10)$$

and

$$SN = \{(1, 0), (1, 1), (0, 1), (-1, 1), (-1, 0), (-1, -1), (0, -1), (1, -1)\}. \quad (11)$$

$nnd(v)$ outputs one of the 8 unit vectors in SN which has the minimum angle distance with the newly generated velocity v . By using the function $nnd(\cdot)$,

Algorithm 1: CCPSO-R

```
1 Initialization
2 while the prey is not captured and time limit is not reached do
3   for each subpopulation do
4     Re-evaluate the subpopulation due to environmental changes
5     for each virtual robot do
6       Update its velocity and position using (8) and (9)
7       Evaluate the fitness together with the rest real predator robots
8     if unique virtual robots <  $T_v$  then
9       Re-initiate and re-evaluate the virtual robots
10    Update the velocity and position of the real predator robot using
        (13) and (14)
11    Evaluate the fitness of the real predator robot together with the
        rest real predator robots
12    if the real predator robot becomes the global best then
13      Re-initiate and re-evaluate the virtual robots
14    else if the predator robot gets trapped in the local optimum then
15      Add a random noise to the real predator robot's position
16      Re-evaluate the whole population
17  if the real predator robots swarm get trapped in the local optimum
        then
18    Add random noises to all the real predator robots' positions
19    Re-evaluate the whole population
```

every robot can only move one step by one step. In this way, unlike the multi-steps case in a general PSO, the path planning and the worry about collisions in the half way to a destination are not ever necessary. v_{robots}^{ij} is the velocity for the j th individual (robot) in the i th subpopulation which has the position p_{robots}^{ij} . In addition, p_{robots}^{ij} is the individual historical best position for the

j th individual (robot) in the i th subpopulation, while pg_{robots}^i is the global best position of the i th subpopulation. The coefficient $w \in R$ is called the inertia weight, $c_1, c_2 \in R^+$, and r_1, r_2 are uniformly distributed random numbers in the range of $(0, 1)$. Besides,

$$nbn(p_{robots}^{ij}, p_{robots}^{i1}) = \begin{cases} \arg \min_{p_b^{i1}} |\angle(p_b^{i1} - p_{robots}^{i1}) - \angle(p_{robots}^{ij} - p_{robots}^{i1})|, & \text{if } p_{robots}^{ij} \text{ is out of the vicinity of } p_{robots}^{i1} \\ p_{robots}^{ij}, & \text{else} \end{cases} \quad (12)$$

outputs the nearest boundary neighbor p_b^{i1} in the constrained vicinity of the real predator robot p_{robots}^{i1} . This function is illustrated in Figure 7, where the constrained vicinity of p_{robots}^{i1} is shown in a dashed square, which is determined as the minimum one that can accommodate all the unique virtual robots. Note that, the $nbn(p_{robots}^{ij}, p_{robots}^{i1})$ function in Equation (9) is very important because it can assure all the virtual robots p_{robots}^{ij} ($j \geq 2$) are in the constrained vicinity of the real predator robot p_{robots}^{i1} , without which the subpopulation may lose the vicinity exploring capability for the real predator robot.

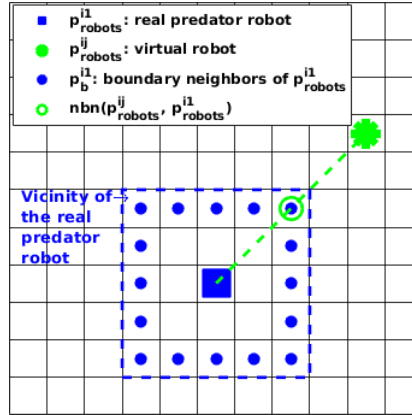

Figure 7: Illustration of the function $nbn(p_{robots}^{ij}, p_{robots}^{i1})$ in Equation (12).

2. For the real robot ($j = 1$), the PSO update rules are as follows:

$$v_{robots}^{i1} = nnd(pg_{robots}^i - p_{robots}^{i1}) \quad (13)$$

$$p_{robots}^{i1} = p_{robots}^{i1} + v_{robots}^{i1} \quad (14)$$

So, the real predator robot does not need to perform any exploring task, but just quickly becomes the global best in its subpopulation.

To summarize, by utilizing different optimization mechanisms for different kinds of robots, virtual robots are responsible for exploring and finding potential better positions in the vicinity of the real predator robot, while the real predator robot in each subpopulation just makes use of the achievements of the virtual robots and becomes the global best.

3.2.2. Fitness evaluation

From the practical point of view, no collisions of any two real robots are allowed. Since we have totally N_s subpopulations in the cooperative coevolution population, a priority scheduler is used to coordinate among them, as shown in Figure 8.

To be as simple as possible, here we let the priorities be in consistent with the indexes of the subpopulations. In another word, after the prey robot moves, the subpopulations evolve one-by-one and the newly updated real predator robot is counted into the dynamics of the environment for the fitness evaluations of the following subpopulations. So, if $k > h$, the predator p_{robots}^{k1} always moves ahead of the predator p_{robots}^{h1} .

To evaluate the fitness of the j th individual in the i th subpopulation, a complete solution should be first composed by replacing the i th real predator robot with p_{robots}^{ij} from the real predator robots swarm:

$$\left[p_{robots}^{11}, \dots, p_{robots}^{(i-1)1}, p_{robots}^{ij}, p_{robots}^{(i+1)1}, \dots, p_{robots}^{N_s 1} \right].$$

Then, the fitness of a robot can be evaluated by (2).

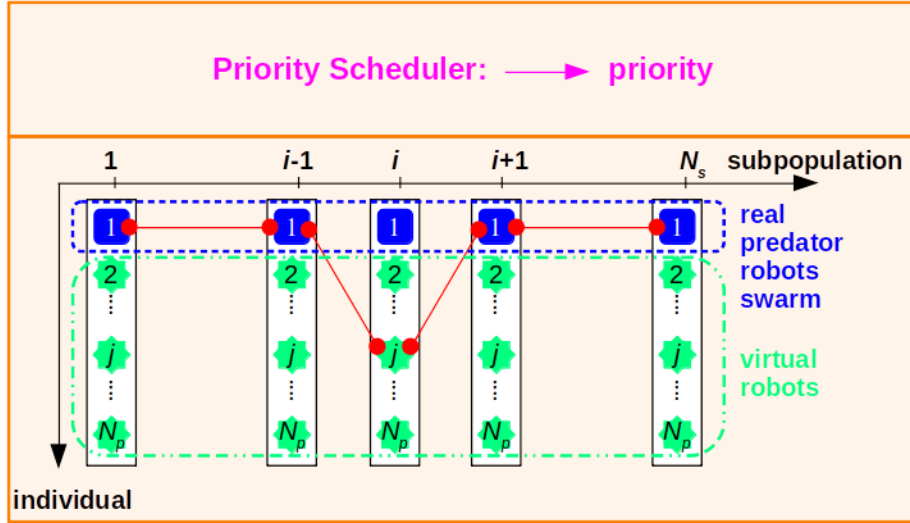

Figure 8: Illustration of the priority scheduler for the CC based fitness evaluation.

3.2.3. Diversity maintenance mechanism

When a swarm intelligence algorithm converges, all individuals may be attracted to the same position, no matter it is the global or local optimum. However, for the pursuit case here, the convergence of virtual robots in a subpopulation brings the disadvantage that the capability of exploring potential better positions is getting worse. Therefore, if the number of unique virtual robots in a subpopulation is defined as the subpopulation diversity, the diversity of each subpopulation must be maintained to keep its exploring capability. Besides, due to the existence of unexpected deadlocks, suitable strategies should be integrated in the coordination algorithm to deal with such problems.

Based on the above ideas, we propose the diversity maintenance mechanisms which are performed as follows:

- Update the population in each generation based on the scheme that the fitness of the newly generated individual is not worse than its parent robot, which will guide the robot to explore more positions with no harm to the fitness.
- Redistribute the virtual robots once the number of unique virtual robots'

positions in a subpopulation decreases below a threshold T_v , i.e., the subpopulation converges. That is, the subpopulation has found better solutions and all robots are attracted to the global best. In this situation, virtual robots should be redistributed to the space for better exploration. This strategy corresponds to the lines 8-9 in Algorithm 1.

- Redistribute virtual robots once the real predator robot becomes the global best in the subpopulation. Because the role of virtual robots is to help the corresponding real predator robot to find better positions, once this real predator robot becomes the global best in its subpopulation, the object of virtual robots is reached and they should be redistributed to the space to find potential better positions for the real predator robot. This strategy corresponds to the lines 12-13 in Algorithm 1.
- Add a random noise to the position of the real predator robot if it is not the global best in its subpopulation but abnormally keep stills for a long time, in which it must get stuck in a deadlock. This strategy corresponds to the lines 14-16 in Algorithm 1.
- Add random noises to the positions of all the real predator robots if they converges under the situation that the prey robot has not been captured. This strategy corresponds to the lines 17-19 in Algorithm 1.

4. Experiments

In this section, several experiments are conducted in a 30×30 grid world to verify the performance of the proposed CCPSO-R. In particular, to verify the generality of CCPSO-R, four types of preys are implemented. The prey robot is initially put in the center of the world, but behaves differently according to its type defined as follows:

- STILL PREY: the still prey keeps still in its initial position forever.
- RANDOM PREY: the random prey randomly moves to a next position according to the uniform distribution.

- LINEAR PREY: the linear prey chooses one of the 8 directions in which the number of predator robots is minimum, and moves in that direction in a straight line. However, when the way of the linear prey is blocked by a predator robot, it cannot move any more but wait for the other predator robots coming to encircle it.
- SMARTER LINEAR PREY: the smarter linear prey, represented as linear_smart, is very similar to the linear prey. The only difference is that when its way is blocked by a predator robot, it moves to an occupied neighbor which has the minimum angle distance with its current direction and after that it continues to move in the previous direction if there are obstacles.

From the above descriptions, the capabilities of the preys can be intuitively ranked as "still prey < random prey < linear prey < linear_smart prey", which will be further verified by the following experiments. Moreover, to verify the scalability of CCPPSO-R, various sizes of the predators swarm are used, from which we can expect the advantages originated from the swarm intelligence of the swarm predator robots.

The other implementation details are as follows: the initial real predator robots are deployed randomly in the whole grid world without overlapping, the population size of each subpopulation is 20, the prey robot moves in 90% of the time, $D_{min} = 1$ in equation (3), and parameters in equation (9) are set as $w = 1, c_1 = c_2 = 2$.

In addition, note the line 4 in Algorithm 1, i.e., when a subpopulation is re-evaluated due to the past changes in the environment, e.g., the changes of the real predator robots' positions in the other subpopulations, the individual historical best position pi_{robots}^{ij} will not be inherited, and the global best pg_{robots}^i will be re-calculated here. This is because, although the experimental results of inheriting and not inheriting the individual historical memory pi_{robots}^{ij} differ, it is hard to select either one due to their competitive performances.

As for the performance metrics, we use the number of captures, the average

number of moves to capture the prey, and their standard derivatives from 100 randomly generated test cases given the maximum 1000 time steps, the random seeds of which are set as 1 to 100.

4.1. Simulation results and discussion

The simulation results are summarized in Table 1, from which it can be seen that CCPSO-R is reliable with the capture rate being 100% in a limited time, no matter what type of the prey it is. As expected before, to a swarm of predator robots, the difficulties, in terms of the average number of moves, to capture each type of prey can be generally ranked as "still prey < random prey < linear prey < linear_smart prey", which can be seen more clearly from Figure 9. This conclusion is in consistent with the common opinion in literatures (such as [5] and [13]) that compared with the random prey, the straight line moving prey is more effective because it breaks the movement locality. Hence, the straight line moving prey is more difficult to be captured, which leads to the low capture rates in previous work, such as the manually designed methods [2, 5], EA based method [5] and the case learning method [6].

In addition, we show the data of Table 1 in the manner of Figure 10, from which an evident fact can be found that the more predator robots the more efficient the pursuit is. Besides, from the decreasing standard derivatives as more real predator robots are involved, as shown in Figure 9, it can be concluded that with the swarm size of the predator robots gets larger, the pursuit performance is getting more and more stable and robust.

To give a more intuitive impression to the pursuit process, several representative episodes taking from an experiment of the linear_smart prey are displayed in Figure 11.

5. Conclusions

This paper treated the pursuit domain as an optimization problem and presented the cooperative coevolutionary algorithm – CCPSO-R, which, for the

Table 1: Number of captures, average number of moves, and their standard deriviations to capture different preys with various number of predators out of 100 test cases.

Number of Predators		Prey			
		Still	Random	Linear	Linear_Smart
4	Captures	100	100	100	100
	Avg. of moves	30.450	49.840	46.900	204.060
	Std. of moves	19.943	36.867	31.886	198.927
8	Captures	100	100	100	100
	Avg. of moves	22.220	33.780	42.240	121.820
	Std. of moves	13.384	23.039	46.583	111.922
12	Captures	100	100	100	100
	Avg. of moves	20.470	24.520	30.190	76.780
	Std. of moves	11.364	13.414	24.943	72.839
16	Captures	100	100	100	100
	Avg. of moves	17.360	18.360	25.620	49.850
	Std. of moves	9.648	11.277	23.560	50.048
24	Captures	100	100	100	100
	Avg. of moves	15.060	14.060	19.670	35.400
	Std. of moves	10.688	6.151	21.879	32.588

first time, introduces the combination of the real robots and virtual robots into the correspondences between the individual representation of an EA and the robots in an application. Before our work, an individual in an EA will be assigned to a real robot. However, in our algorithm, only the first individual in each subpopulation corresponds to a real robot, while the rest individuals are all virtual robots, who act as a kind of action space for real robots by sampling and exploring their vicinities.

Besides, it should be noted that there are no fixed behavior rules for the predator robots swarm. Instead, the robots swarm are guided immediately by

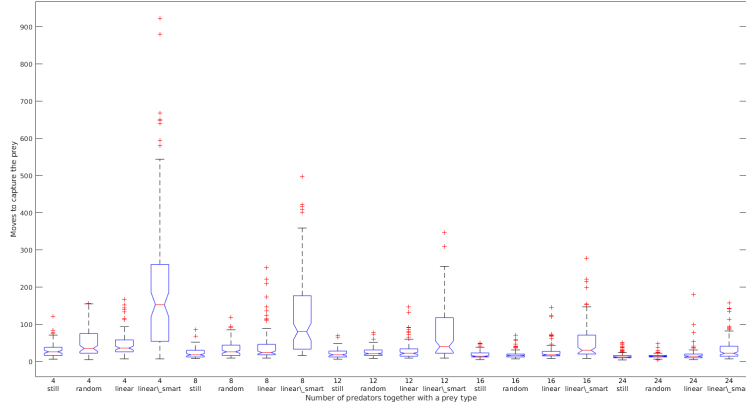

Figure 9: Box plot of the moves to capture a specific prey with a specific number of predator robots.

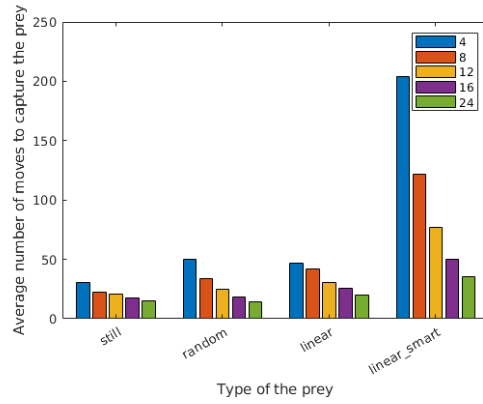

Figure 10: Bar graph of the average moves to capture a specific prey with a specific number of predator robots.

the fitness function, which is designed in a modular manner by incorporating very limited domain knowledges. As one module, the collision avoidance consideration is integrated in the fitness function, which itself is another fitness function for repelling and can be versatile by tuning its parameter D_{min} . If the $D_{min} = 1$, as it is in this paper, the robot swarm can capture the prey while moving without collisions.

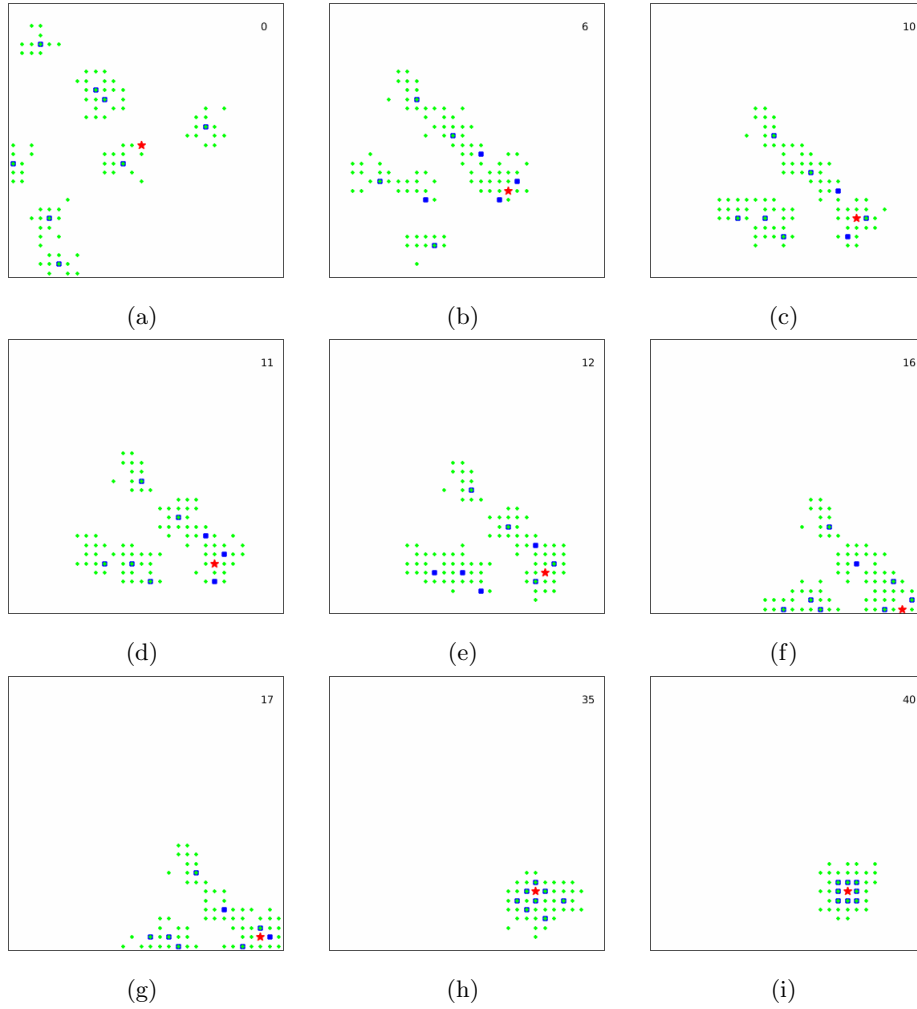

Figure 11: Illustration of the pursuit process, taking the linear_smart prey as an example. (a) is the initialization. From (a)-(b), the prey moves in the southeast direction in a straight line. In (c), the prey encounters an orthogonal real predator robot. So, in (d), the prey moves to a nearest unoccupied neighbor in the south. After that, from (d) to (e), the prey continues to move in its previous straight line direction. Until (f), the prey reaches an edge. So, in (g), the prey re-selects the north as its new escape direction. In (h), the prey is captured. And in (i), the predator robots swarm converge.

Finally, we tested the performance, the genearity, and the scalability of CCPSO-R with four types of preys – the still prey, the random prey, the linear prey, and the linear_smart prey. Experimental results have been summarized based on 100 randomly generated test cases whose random seeds are set as 1-100 for their reproducibility. Based on these trials, it can be concluded that CCPSO-R can always capture the prey stably and no additional modifications are needed for different scenarios.

However, to be simple, the coordination priority scheduler was designed based on the subpopulation indexes, which indicates that the real predator robots move in a fixed sequential order. This may be unreasonable when it is better to firstly move one specific predator which blocks others' way. In addition, predators move sequentially, rather than synchronously, will deteriorate the pursuit efficiency when the predators swarm get larger. Therefore, two works need to be done in the future work: one is to improve the coordination scheduler towards the synchronous cooperation based on parallel computing by learning from experiences; the other one is to study the memory inheritance strategy in dynamic optimization problems as mentioned before.

Acknowledgements

We would like to thank Qiqi Duan for his help in this research work.

References

References

- [1] M. Benda, V. Jagannathan, R. Dodhiawala, On optimal cooperation of knowledge sources-an empirical investigation, Technical Report BCS-G2010-28, Boeing Advanced Technology Center, Boeing Computing Services, Seattle, Washington.
- [2] R. E. Korf, A simple solution to pursuit games, in: Working Papers of The 11th International Workshop on Distributed Artificial Intelligence, 1992, pp. 183–194.

- [3] T. Haynes, R. L. Wainwright, S. Sen, Evolving cooperation strategies., in: ICMAS, 1995, p. 450.
- [4] T. Haynes, R. L. Wainwright, S. Sen, D. A. Schoenefeld, Strongly typed genetic programming in evolving cooperation strategies., in: ICGA, Vol. 95, 1995, pp. 271–278.
- [5] T. Haynes, S. Sen, Evolving behavioral strategies in predators and prey, in: G. Weiß, S. Sen (Eds.), *Adaption and Learning in Multi-Agent Systems*, Springer Berlin Heidelberg, Berlin, Heidelberg, 1996, pp. 113–126.
- [6] T. Haynes, S. Sen, Learning cases to resolve conflicts and improve group behavior, *International Journal of Human-Computer Studies* 48 (1) (1998) 31–49.
- [7] J. R. Koza, *Genetic programming*, MIT Press, Cambridge, MA, 1992.
- [8] D. J. Montana, Strongly typed genetic programming, *Evolutionary Computation* 3 (2) (1995) 199–230. arXiv:<https://doi.org/10.1162/evco.1995.3.2.199>, doi:10.1162/evco.1995.3.2.199. URL <https://doi.org/10.1162/evco.1995.3.2.199>
- [9] C. Undeger, F. Polat, Multi-agent real-time pursuit, *Autonomous Agents and Multi-Agent Systems* 21 (1) (2010) 69–107. doi:10.1007/s10458-009-9102-0.
- [10] Y. Ishiwaka, T. Sato, Y. Kakazu, An approach to the pursuit problem on a heterogeneous multiagent system using reinforcement learning, *Robotics and Autonomous Systems* 43 (4) (2003) 245 – 256. doi:[https://doi.org/10.1016/S0921-8890\(03\)00040-X](https://doi.org/10.1016/S0921-8890(03)00040-X).
- [11] S. Barrett, P. Stone, S. Kraus, Empirical evaluation of ad hoc teamwork in the pursuit domain, in: *The 10th International Conference on Autonomous Agents and Multiagent Systems - Volume 2, AAMAS '11*, International Foundation for Autonomous Agents and Multiagent Systems, Richland, SC, 2011, pp. 567–574.

- [12] S. Barrett, A. Rosenfeld, S. Kraus, P. Stone, Making friends on the fly: Cooperating with new teammates, *Artificial Intelligence* 242 (2017) 132 – 171. doi:<https://doi.org/10.1016/j.artint.2016.10.005>.
- [13] P. Stone, M. Veloso, Multiagent systems: A survey from a machine learning perspective, *Autonomous Robots* 8 (3) (2000) 345–383. doi:[10.1023/A:1008942012299](https://doi.org/10.1023/A:1008942012299).
- [14] M. S. Couceiro, R. P. Rocha, N. M. F. Ferreira, A novel multi-robot exploration approach based on particle swarm optimization algorithms, in: 2011 IEEE International Symposium on Safety, Security, and Rescue Robotics, 2011, pp. 327–332. doi:[10.1109/SSRR.2011.6106751](https://doi.org/10.1109/SSRR.2011.6106751).
- [15] S. L. Devadoss, J. O’Rourke, *Discrete and computational geometry*, Princeton University Press, 2011.