

Evaluating Endpoint-to-Path Cooperation in the Mobile Network using a 1-bit Rate-Delay Signal

Thomas Fossati[†], Pedro A. Aranda Gutiérrez^{*}, and Diego López[‡]

[†]Nokia, Cambridge, UK

^{*}UC3M, Leganés, Spain

[‡]Telefónica I+D, Madrid, Spain

June 10, 2021

Abstract

This paper evaluates the impact of a Rate-Delay (RD) signal [15] – specifically, the one described in [19] – on traffic crossing the mobile network through a set of experiments in a simulated LTE network built with ns-3 [14]. In our experiments, we compare a scenario with no RD treatment (i.e. a single best-effort Evolved Packet System (EPS) bearer) with scenarios with RD treatment (i.e. separate EPS bearers to carry RD-partitioned traffic) with honest and cheating users. Our objective is twofold: On the one hand, we want to explore the suitability of RD as a way to harmonize the Long-Term Evolution (LTE) and Internet Quality of Service (QoS) models. On the other hand, we aim at providing data to inform protocol design as well as operations-related discussion on the notion of exposing a 1-bit, clear-text RD signal from endpoints to the network path when the use of end-to-end encrypted protocols would otherwise prevent flow classification based on Deep Packet Inspection (DPI). Specifically, the question we want help answer is whether the gain in terms of end users' Quality of Experience (QoE) and radio spectrum efficiency is enough to justify making room for such signal. All the experiments are fully documented and

the tooling used is made available as open-source to ensure their reproducibility.

1 Introduction

The amount of IP traffic flowing through the Mobile network is projected to represent 20 percent of total IP traffic in the next five years, with 4G amounting to more than three quarters of the share [6]. Despite Long-Term Evolution (LTE) offering fine-grained Quality of Service (QoS) control [1], the typical 4G network at the time of this writing is configured to carry all Internet-bound traffic over the same default Evolved Packet System (EPS) bearer. This means that all flows competing at the bottleneck link – which is usually located in the Radio Access Network (RAN) – are treated equally according to the QoS Class Identifier (QCI) parameters associated with the default bearer, i.e. 300ms latency and 10^{-6} loss budgets. The latency bounds, in particular, are incompatible with interactive applications e.g. Skype, Web based Real-Time Communication (WebRTC), online gaming, as well as machine to machine applications (e.g., V2X), that critically require a low delay end-to-end path. All these latency-sensitive flows would probably benefit if isolated from other buffer filling flows, especially when the bottleneck link is congested. When the induced queueing delay is not properly bounded, the user experience of an interactive application can become very frustrating. Mobile Network Operators (MNOs) over-provision their infrastructure to avoid congestion in the first place [13]. But this strategy is clearly not sustainable, as the spectrum is constrained by physics and cellular traffic is only destined to grow in the coming years [6]. The LTE QoS model is quite rich, providing 15 different QCIs; so, what are the reasons pushing MNOs to completely ignore it for Internet-bound traffic? Firstly, there is a cost argument related to the maintenance of dedicated EPS bearers, including configuration, increased control plane signaling to deal with the setup and teardown operations, and run-time state that needs to be coordinated across a variety of different LTE network nodes. Secondly, the uncertainties associated with mapping an incoming flow to the right EPS bearer, which include the trust issue linked with QoS signaling at network interconnections: MNOs have no incentives to honour QoS markings that are set by other administrative domains, and possibly even by their own end-users [7]. In addition, flow classification at line-rate is going to become much more difficult because of the

raise of encrypted and multiplexed transports (e.g. QUIC [11]) which are, by definition, not amenable to deep inspection. Finally, the historical aversion of MNOs to favor Over-the-top (OTT) real-time communication providers that are competing with their own (MNOs-supplied) voice and video services and on their infrastructure. We note, though, that this position is being re-evaluated thanks to the widespread adoption of applications such as Facebook Messenger, Skype, Telegram or Viber on smart phones. If we manage to solve, or at least mitigate, the issues listed above, we could grab the optimization opportunity that is hanging just in front of us. Our intuition is that the Rate-Delay (RD) approach [15, 19] might be the silver bullet. In fact, RD addresses the cost argument by reducing the number of dedicated bearers to only one: QCI 7 seems to be fit for purpose, having a 100ms delay upper-bound, at the cost of higher packet loss. RD also solves the trust issues by creating a cooperative game between endpoints and the network in which participants have no incentive to cheat. In fact, misrepresenting the real nature of flows results in self-inflicted, unwanted, higher delay or loss as a consequence of false signaling. Given the latter, the problem of efficient flow classification could be solved by convincing encrypted traffic sources to explicitly mark their traffic using a clear-text signal at a known position in packets. If such signal was available, the mobile network could instantiate the appropriate Traffic Flow Templates (TFTs) and dispatch at line-rate. Finally, the cost of extra state and control plane signaling needed by the dedicated low latency bearer could be traded-off with the better utilisation of radio resources that comes from the more relaxed Automatic Repeat Request (ARQ) configuration required by the extra bearer to implement its shallow queue.

1.1 Contribution

In this paper, we verify that we can use QCI 7 to implement the RD trade-off by measuring the impact of using such strategy on end users' Quality of Experience (QoE). We describe and document a series of experiments conducted using the ns-3 LTE module in order to compare the effect of RD markings on traffic crossing a LTE network vs the best effort option, where no traffic classification whatsoever exists. To the best of our knowledge, this is the first time RD has been evaluated for use in mobile networks.

1.2 Organization of the paper

The rest of the paper is structured as follows: in Section 2 we motivate the use of traffic classification using the RD trade-off; in Section 3 we discuss the experimental setup used in the measurements and, finally, in Section 4 we present our conclusions and discuss further work.

2 State of the Art

End-to-end services in the Internet have been traditionally provided on a best-effort basis. First approaches based on Integrated Services (IntServ), as described in RFC 2210 [18], tried to signal QoS in an end-to-end path by installing per-flow state in the network devices proved not to be scalable. An alternative approach to provide better than best-effort in IP networks is Differentiated Services (DiffServ) as described in RFC 2475 [4]. DiffServ can be used in a single domain to classify packets and make them experience a specific Per-Hop Behaviour (PHB) that controls the QoE. Attempts at providing scalable QoS management frameworks [12] and testbeds [16] were done during the late 1990's and early 2000's. A full analysis of the technical and non-technical evolution of the approach to implementing enhanced services in the Internet is provided in [7]. Over-provisioning in IP networks and, specifically, in mobile networks as a means to avoid congestion is documented in [13]. The migration of large volumes of traffic from clear-text to encrypted communications in the Internet is a confirmed trend, as partially reflected in the increased use of encrypted Web traffic [9]. Encryption, combined with flow multiplexing, impacts the accuracy traditional traffic classification methods [2], which are normally implemented in network equipment used by MNOs. In an end-to-end encrypted scenario, the only reasonable place to put QoS-related markings is in clear-text parts of the network or transport layer protocols. In order to avoid man-in-the-middle attacks degrading the QoE, it is desirable that these QoS-related markings are cryptographically protected. Such a scenario, where marking and traffic classification to improve QoE need user cooperation, calls for a framework that rewards honest and penalizes dishonest use of QoS markings. One such approach is presented in [15], where services are marked and treated depending on whether they request high rates or low delay. High transmission rates imply the presence of large queueing buffers to avoid loss, while low delay implies small queueing

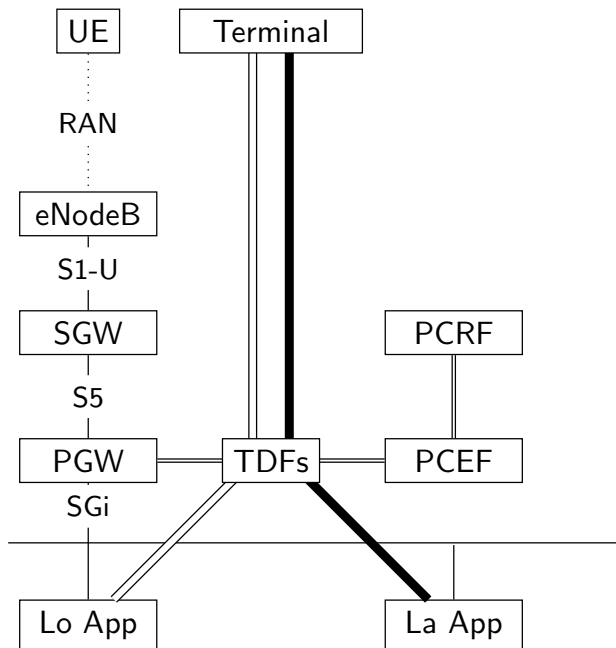

Figure 1: Scenario used in the simulations

buffers. A user requesting the wrong traffic class will be penalized, because small queueing buffers are detrimental for high-rate traffic and long queueing buffers will imply higher delay under high network utilization. This approach was proposed in [19] as a possible PHB for IP networks with DiffServ.

3 Experiments

We use a number of ns-3 based simulations to measure the impact of RD signalling coupled with a simplified LTE QoS setup that uses one dedicated low-latency bearer in addition to the default bearer.

The crucial characteristic of this QoS framework is that cheating (i.e., using a certain marking to obtain an advantage over competing flows) makes no sense to the end user because it may actually degrade their QoE. This property is explicitly proven by one of our experiments.

In our implementation, we use the low-latency DiffServ codepoint (DSCP)

| | | |
|----------|-------------------------------------|---------------------------------|
| LTE-uu | FDD SISO, 6 RB baseline latency: | downlink peak: 4.4Mbit/s 3ms |
| S1/S5/S8 | Data rate: propagation latency: | 5Mbit/s 0ms |
| SGi | data rate: propagation latency: | 10Gbit/s 1ms |
| eNB | proportional fair MAC scheduler | |
| Bearers | default | QCI 9 |
| | dedicated low-latency | QCI 7 |

Table 1: Configuration used in mobile simulations

defined in [19]. This choice makes it trivial to specify the matching Traffic Flow Template (TFT) in the simulation environment. It should be noted though that the use of the Loss-Latency Trade-off (LLT) marking scheme in this context is just exemplary and, as long as the marker and the classifier agree on the position and semantics of the signal used to identify low latency flows, the specific kind of marking is irrelevant.

Fig. 1 shows the different elements and flows that are used in the experiments. The white flow represents a greedy TCP flow that is not application limited (e.g., a large file download). The black flow represents a one way real-time flow with a bandwidth of 64kbps (e.g., a real-time audio flow). Marking, classification and the corresponding queuing strategy depend on the scenario we test. For each set of QoS settings we provide a control measurement where we apply the traffic to the network with these settings deactivated and the experiment proper, where they are activated.

The configuration of the SGI-LAN, LTE core and radio segments used in all the experiments is described in Table 1.

To evaluate the experiments, we use latency (delay and jitter) statistics. In order to calculate the delay, we include a timestamp in the low-latency packets and calculate the delay with the arrival timestamp. The jitter is calculated from the set of measured delays d_1, \dots, d_N using the following formula [3]:

$$jitter = \frac{1}{N-1} \sum_{i=1}^{N-1} |d_{i+1} - d_i|$$

| Stream type | Run | Delay | | | Jitter |
|-------------|------------|-------|-----|-----|--------|
| | | mean | min | max | |
| audio | control | 15.48 | 5 | 24 | 4.43 |
| | experiment | 4.32 | 4 | 6 | 0.72 |
| video | control | 16.15 | 6 | 26 | 4.69 |
| | experiment | 8.39 | 7 | 10 | 0.66 |

Table 2: Real-time flow latency (ms) in experiment 1

| Run | Throughput |
|------------|--------------|
| no marking | 3.807 Mbit/s |
| marking | 3.793 Mbit/s |

Table 3: TCP throughput in experiment 1

3.0.1 Experiment 1: The Honest Marker

In this experiment, we use two flows simulating a file download and a real-time flow. We characterize the flows in the control with no marking: the mobile network will put both on the same default bearer. Then we enable LLT marking on the real-time flow, which is routed through the dedicated low-latency bearer as a consequence. We simulate audio and video streams by controlling the size of the packets and the rate at which they are generated. In addition to measuring the QoE parameters of the Constant Bit Rate (CBR) flow, we also examine the throughput of the TCP flows.

Table 3.0.1 compares the latency of the real-time flow in the control scenario and the experiment. With the marking enabled a reduction by 72% in the latency of the audio stream is achieved.

When we now examine the throughput of the TCP flow, Table 3.0.1 shows that the measured throughput is slightly reduced when marking is used. However, a variation of -0.39% will likely have no impact on the experienced QoE.

Takeaway 1. Improved delay and jitter for the real-time flow with negligible decrease in efficiency of the throughput seeking flow (and therefore of the RAN as a whole).

3.0.2 Experiment 2: The Cheater

In this scenario, we run two greedy TCP flows (large file downloads) and a concurrent real-time flow. We enable LLT marking on the real-time flow both in the control and the experiment. In the experiment, we also mark one of the greedy TCP flows in order to route it through the low latency bearer together with the real-time flow. This TCP flow simulates the cheater.

In this case, we use TCP retransmissions and the throughput to compare both runs. As shown in Table 3.0.2 the cheater ends up retransmitting a lot more (+460%) which implies a substantial decrease in throughput: The cheater gets -27.5% throughput (honest gets a 18.85% boost as a consequence), as shown in Table 3.0.2. Additionally, as shown in Table 3.0.2, we observe that the real-time flow of the cheater is not affected by the cheating TCP flow.

Takeaway 2. Cheating penalizes the throughput of the greedy TCP flow significantly, while *not* degrading the real-time flow.

| Run | Honest | Liar |
|------------|--------|------|
| no marking | 24 | 25 |
| marking | 31 | 140 |

Table 4: Number of TCP retransmissions in experiment 2

| Run | Honest | Liar |
|------------|--------------|---------------|
| no marking | 2.019 Mbit/s | 1.837 Mbits/s |
| marking | 2.400 Mbit/s | 1.332 Mbits/s |

Table 5: TCP throughput in experiment 2

3.0.3 Experiment 3: Multiple UE connected to one eNodeB

In this experiment, we want to see how the system behaves when we have many users together. For this experiment, we increase the bandwidth at the S1, S5 and S8 interfaces to 50 Mbps. We assume that marking users are *honest* users and examine the perceived QoE of marking and non-marking

| Run | Mean | Min | Max | Stddev |
|------------|-------|-----|-----|--------|
| no marking | 5.373 | 4 | 9 | 1.156 |
| marking | 5.373 | 4 | 9 | 1.156 |

Table 6: Influence on real-time latency (ms) of the cheater in experiment 2

users as the number of marking users increases in a constant population that produces an aggregate bandwidth of latency-sensitive flows that does not surpass the bandwidth available at the RAN (i.e., the bottleneck).

We worked with a population of 20 User Equipment (UE) per eNodeB. Each UE receives a UDP stream simulating a video/audio stream and TCP traffic from a greedy application running in the background. In each run, we had a fraction of the UE receive the CBR stream through the dedicated low latency bearer, while the rest used the default bearer for both streams. The UDP streams were started at random times uniformly distributed between 1 and 3 s, the streams lasted for 10 s and the simulator ran for 14 s, assuring that the full CBR stream was captured. We simulated an audio stream carried over RTP (over UDP) with the following characteristics separately:

| Stream type | Packet size | PPS | effective BW | IP layer BW | # of nodes |
|-------------|-------------|-----|--------------|-------------|------------|
| audio | 160 | 50 | 64 | 80 | 20 |
| video | 100 | 400 | 320 | 352 | 10 |

Table 7: CBR stream parameters. Packet sizes are in bytes, bandwidth (BW) is in kbit/s

Fig. 2 shows the delay (d) and jitter (j) measured in each of the UE. The measurements are grouped by colours depending on whether the node received a marked or an unmarked audio stream. It can be clearly appreciated that when marking was used (i.e., when QCI 7 was used for latency-sensitive traffic) the nodes perceive significantly lower delay and jitter. This implies that using LLT marking in these streams produced much better QoE. In particular, it is a well known fact [10] that the quality of a voice call degrades rapidly where the mouth-to-ear delay latency exceeds 200 ms.

We then repeated the experiment with 10 nodes and a 320kbit/s UDP CBR (video) flow competing with a greedy TCP flow per node. We observe

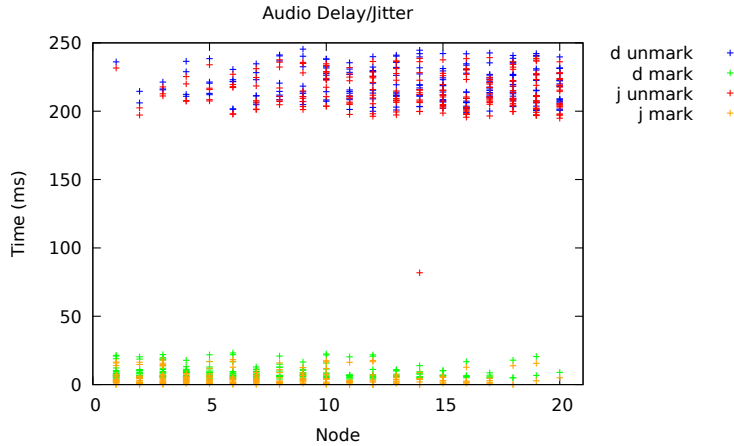

Figure 2: QoE parameters for 20 CBR flows @ 64kbit/s

the same behaviour, i.e., that marking yields better QoE behaviour than not marking. The results are shown in Fig. 3.

Takeaway 3. The dedicated low-latency bearer produces extremely good results, with delays one order of magnitude less than the default bearer.

4 Conclusions

The simulations performed around low latency support mechanisms in mobile networks show very promising results. Moving the idea out of the testbed requires first of all agreeing among the involved parties (mobile networks and applications) on the format and semantics of the core signalling. A mechanism based on Non Queue Building Flows (NQB) [17] has been recently proposed by the authors in the IETF TSV working group [8]. This approach has the advantage of harmonising the signalling between fixed and mobile access and at the same time not precluding the possibility to further experiment with Low Latency Low Loss Scalable throughput (L4S) [5]. This is the groundwork needed for a few other standards and dissemination activities which include at a minimum: recommendations for endpoint and API developers (for example, IETF RTCWEB, W3C WebRTC, M2M-related SDOs), and guidelines for mobile network operators – ideally via GSMA.

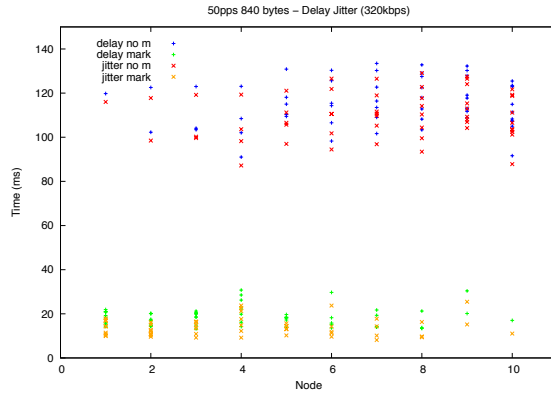

Figure 3: QoE parameters for 10 CBR flows @ 320kbit/s

References

- [1] Technical Specification Group Services and System Aspects; licy and charging control architecture (Release 14). Technical specification, 3rd Generation Partnership Project, June 2017.
- [2] G. Aceto, D. Ciunzo, A. Montieri, and A. Pescapè. Multi-classification approaches for classifying mobile app traffic. *Journal of Network and Computer Applications*, 103, 11 2017.
- [3] E. Amir. Unreliable transport. <http://nms.lcs.mit.edu/~hari/papers/CS294/paper/node5.html>, may 1996.
- [4] S. Blake, D. Black, M. Carlson, E. Davies, Z. Wang, and W. Weiss. An Architecture for Differentiated Services. Technical Report 2475, IETF Secretariat, December 1998.
- [5] B. Briscoe, K. D. Schepper, and M. Bagnulo. Low Latency, Low Loss, Scalable Throughput (L4S) Internet Service: Architecture. Internet-Draft draft-ietf-tsvwg-l4s-arch-03, Internet Engineering Task Force, Oct. 2018. Work in Progress.
- [6] Cisco. Cisco visual networking index: Global mobile data traffic forecast update, 2016–2021. Technical report, Cisco Systems Inc., February 2017.
- [7] K. Claffy and D. Clark. Adding Enhanced Services to the Internet: Lessons from History. In *Telecommunications Policy Research Conference (TPRC)*. TPRC, Elsevier, Sep 2015.

- [8] T. Fossati, G. Fairhurst, P. A. A. Gutierrez, and M. Kühlewind. A Loss-Latency Trade-off Signal for the Mobile Network. Internet-Draft draft-fossati-tsvwg-lola-00, Internet Engineering Task Force, Dec. 2018. Work in Progress.
- [9] Internet Security Research Group. Let’s Encrypt Statistics, January 2016.
- [10] ITU-T G.144, One-way transmission time. Recommendation, International Telecommunication Union, May 2003.
- [11] J. Iyengar and M. Thomson. QUIC: A UDP-Based Multiplexed and Secure Transport. Internet-Draft draft-ietf-quic-transport-11, Internet Engineering Task Force, Mar. 2018. Work in Progress.
- [12] H. A. Mantar, J. Hwang, I. T. Okumus, and S. Chapin. A scalable intra-domain resource management scheme for diffserv networks. 15, 01 2006.
- [13] Martin Geddes. Over-provisioning bandwidth doesn’t solve QoE problems, June 2014.
- [14] ns-3 Consortium. ns-3 Network Simulator, 2011-2018.
- [15] M. Podlesny and S. Gorinsky. Rd network services: differentiation through performance incentives. In *Proceedings of the ACM SIGCOMM 2008 Conference on Applications, Technologies, Architectures, and Protocols for Computer Communications, Seattle, WA, USA, August 17-22, 2008*, pages 255–266, 2008.
- [16] B. Teitelbaum and R. Geib. Internet2 QBone: a testbed for differentiated services. https://www.isoc.org/inet99/proceedings/4f/4f_1.htm, 1999.
- [17] G. White. Identifying and Handling Non Queue Building Flows in a Bottleneck Link. Internet-Draft draft-white-tsvwg-nqb-00, Internet Engineering Task Force, Oct. 2018. Work in Progress.
- [18] J. Wroclawski. The Use of RSVP with IETF Integrated Services. Technical Report 2210, IETF Secretariat, September 1997.
- [19] J. You, M. Welzl, B. Trammell, M. Kühlewind, and K. Smith. Latency Loss Tradeoff PHB Group. Internet-Draft draft-you-tsvwg-latency-loss-tradeoff-00, Internet Engineering Task Force, Mar. 2016. Work in Progress.