

# Neural Machine Translation based Word Transduction Mechanisms for Low-Resource Languages

Saurav Jha<sup>\*</sup>, Akhilesh Sudhakar<sup>†</sup>, and Anil Kumar Singh<sup>‡</sup>  
IIT (BHU), Varanasi, India

## Abstract

Out-Of-Vocabulary (OOV) words can pose serious challenges for machine translation (MT) tasks, and in particular, for Low-Resource Languages (LRLs). This paper adapts variants of seq2seq models to perform *transduction* of such words from Hindi to Bhojpuri (an LRL instance), learning from a set of cognate pairs built upon a bilingual dictionary of Hindi-Bhojpuri words. We demonstrate that our models can effectively be used for languages that have a limited amount of parallel corpora, by working at the character-level to grasp phonetic and orthographic similarities across multiple types of word adaptations, whether synchronic or diachronic, loan words or cognates. We provide a comprehensive overview over the training aspects of character-level NMT systems adapted to this task, combined with a detailed analysis of their respective error cases. Using our method, we achieve an improvement by over 6 BLEU on the Hindi-to-Bhojpuri translation task. Further, we show that such transductions generalize well to other languages by applying it successfully to Hindi-Bangla cognate pairs. Our work can be seen as an important step in the process of: (i) resolving the OOV words problem arising in MT tasks, (ii) creating effective parallel corpora for resource constrained languages, and (iii) leveraging the enhanced semantic knowledge captured by word-level embeddings onto character-level tasks.

*Keywords: Neural machine translation, Hindi-Bhojpuri, word transduction, low resource language, attention model*

---

<sup>\*</sup>mail@sauravjha.com.np

<sup>†</sup>akhileshs.s4@gmail.com

<sup>‡</sup>aksingh.cse@iitbhu.ac.in

*Since this is an elaborate section setting the stage for our work, we conclude it with a highly concise view provided in Subsection 1.3. This view is meant to ensure that the perspective of our work is consolidated and is presented to the reader in a gist, after the reader has been familiarized with the context leading up to our work.*

With recent advancements in the field of Machine Translation (MT) and Neural Machine Translation (NMT) in particular, there has been an increasing need to shift focus to OOV words. In the case of Low Resource Languages (LRL), which lack in linguistic resources such as parallel corpora, the problem promptly comes within sight, with most words being OOV words. Current data-intensive translation systems work poorly with OOV words in LRLs, purely because of a severe lack of resources. Hence, for these types of languages, it becomes necessary to deal with OOV words in specific ways, outside the ambit of generic NMT systems. Even in the case of resource-rich languages, methods to deal with OOV words are still being actively researched.

Many approaches (as elaborated upon in Section 7) have been investigated to deal with the OOV problem. In this paper, we use the method of ‘transduction’, learned from a dictionary of cognate word pairs between Hindi and Bhojpuri. The fundamental guiding principle of our approach is the fact that Bhojpuri and Hindi are closely related languages, and hence have a good amount of vocabulary overlap while sharing orthographic and phonetic traits. Both these languages have common ancestors, and both of them are written in the Devanagari script. Tracing the origin of a considerable portion of the modern Bhojpuri vocabulary could weakly suggest its origin as a pidgin of Hindi, many of whose words got adapted to the local Bhojpuri phonology with the passage of time. The basis of such reasoning could be derived from the fact that several of other closely related language pairs (*Macedonian-Bulgarian, Spanish-Catalan, Turkish-Crimean Tatar, Czech-Slovak, Irish-Scottish Gaelic*) share a close ancestor within the language family they belong to.

The Indian linguistic space, as reported by Grierson (1928), has 179 independent languages and 544 dialects. Similarly, the survey of Mahapatra *et al.* (1989) demonstrates that there are at least 50 Indian languages in which writing and publishing are done in substantial

quantity. However, a majority of these languages lack proper linguistic resources. Hindi being the *lingua franca* of the ‘Hindi belt’ (most parts of the north) of India, is a commonly spoken language in more than 10 states and has seven major closely related languages, often called ‘dialects’ or ‘sub-languages’, (namely, *Awadhi, Bagheli, Bhojpuri, Bundeli, Haryanvi, Kanauji* and *Khari Boli*) (Mishra and Bali 2011). Despite being amongst the top ten most spoken Indian languages and the most spoken ‘dialect’ of Hindi<sup>1</sup>, Bhojpuri still suffers from the lack of language resources. So far, very little work has been done towards developing language resources (Singh and Jha 2015), resulting in scarcity of resources such as a Bhojpuri WordNet or parallel corpus that could have made state-of-the-art Machine Translation (MT) systems accessible to this language.

Due to the lack of such resources, the traditional Phrase Based Machine Translation (PBMT) approach (Chiang 2005) or NMT (Bahdanau *et al.* 2014) for Bhojpuri becomes infeasible as it requires a massive parallel corpora. In their recent work, Sharma and Singh (2017) introduce a ‘word transduction’ approach to deal with the presence of unknown (or Out of Vocabulary: OOV) words for MT systems involving such resource scarce languages. The concept of word transduction is somewhat similar to Hajic (2000) where the authors suggest that the use of word-for-word translation for very closely related languages provides a good solution for MT of such language pairs (Hindi and Bhojpuri are closely related in the sense that they both use the Devanagari script for all official purposes, with Bhojpuri borrowing many words from Hindi, either directly or with some phonological and/or orthographical changes).

Furthermore, for the task of language translation, it is necessary to take into account the fact that not all languages possess the same morphological features. For example, Finnish has more than 2000 possible inflected noun forms<sup>2</sup>, Hindi and Bhojpuri have more than 40 (Singh and Sarma (2010)), while English has a mere 7-8. Therefore, a good MT system designed for such morphologically rich languages must be intricate enough to deal with their diverse inflectional morphology.

---

<sup>1</sup> [http://www.censusindia.gov.in/Census\\_Data\\_2001/Census\\_Data\\_Online/Language/data\\_on\\_language.aspx](http://www.censusindia.gov.in/Census_Data_2001/Census_Data_Online/Language/data_on_language.aspx)

<sup>2</sup> <https://www.ling.helsinki.fi/~fkarlss/genkau2.html>

In order to address this issue, we adapt character-level NMT systems to our task in order to exploit morphological information encoded in inter-character interactions and intra-word patterns. As observed by Nakov and Tiedemann (2012): “character-level models combine the generality of character-by-character transliteration and lexical mappings of larger units that could possibly refer to morphemes, words or phrases, as well as to various combinations thereof” (Nakov and Tiedemann (2012)). We also introduce a novel pre-trained character-level embedding for Devanagari alphabets derived from the 300 dimensional Hindi fastText embeddings<sup>3</sup>.

As regards the phonetic considerations of transduction, we make use of the fact that Hindi and Bhojpuri have a phonetic writing system, meaning there is an almost one-to-one mapping between phonemes (pronunciation) and graphemes (transcription). This is due to the fact that they both derive from common ancestor languages such as Prakrit and then Apabhramsha (Choudhury 2003). Hence, it suffices to work in either one of the spaces - orthographic or phonetic, and we choose to work in the orthographic space since it does away with the need to convert the graphemes of text to and from phonemes.

Although Bhojpuri phonology is close to that of Hindi, it is not the same. There are notable differences between the two. While Hindi has a symmetrical ten vowel system, Bhojpuri has six vowel phonemes and ten vocoids. Similarly, Hindi has 37 consonants (including those inherited from earlier Indo-Aryan and those from loan words), whereas Bhojpuri has 31 consonant phonemes and 34 contoids. As is usual with any two language pairs, there are many phoneme sequences which are allowed in Hindi, but not found in Bhojpuri and vice-versa. This will be evident from the examples given in the paper later. More details about the Bhojpuri phonology are available in the article by Trammell (1971).

### 1.1 *Transduction and Translation*

Our usage of the word transduction distinguishes it from translation, in that transduction is a task which is trained exclusively on cognates, and in that sense, the dataset it uses is a subset of the dataset that a

---

<sup>3</sup><https://github.com/facebookresearch/fastText/blob/master/pretrained-vectors.md>

translation system would use. **Cognates** are word pairs that not only have similar meaning but are also phonetically (and, in our case, orthographically) similar. The underlying observation that guides the usage of our proposed method of ‘transduction’ of OOV words, as a possible substitute for their translation is as follows:

As stated earlier, Bhojpuri is a language closely related to Hindi. In the case of an OOV Hindi word (or any Hindi word for that matter), there is good chance that the Bhojpuri translation of the word is a cognate of the Hindi word adapted to the phonological and orthographic space of Bhojpuri due to the presence of borrowed words, common origins, geographic proximity, socio-linguistic proximity etc. As mentioned in Sharma and Singh (2017), “A phonemic study of Hindi and Bundeli (Acharya, 2015), mainly focusing on the prosodic features and the syllabic patterns of these two languages (unsurprisingly) concluded that the borrowing of words from Hindi to Bundeli generally follows certain (phonological) rules. For instance if a word in Hindi begins with [ya], it is replaced by [ja] in its Bundeli equivalent as [ya-jamaan] becomes [jajamaan], [yamunaa] becomes [jamunaa] etc. This category of word-pairs is our main motivation behind the work described in this paper.” Being a dialect of Hindi, the above holds true for Bhojpuri.

Our model is agnostic to what sort of words are considered to be OOV (based on their unigram probabilities, their parts-of-speech (POS), or whether they are named entities etc.) because the above assumptions hold uniformly across the language pair. Section 7 specifies some of the metrics that are used to identify OOV words in related work.

Further, the above assumption (of transduction improving overall translation performance) has been demonstrated to be valid in the case of many closely related language pairs, in a number of previous works. For instance, Kondrak *et al.* (2003) extracted a parallel list of cognate word-pairs and re-appended them to the parallel list of all word translations, thereby increasing the training weights of cognate words. Giving added importance to these cognate words, “resulted in a 10% reduction of the word alignment error rate, from 17.6% to 15.8%, and a corresponding improvement in both precision and recall.” (Kondrak *et al.* (2003)). Mann and Yarowsky (2001) used cognates to expand translation lexicons, Simard *et al.* (1993) to align sentences in a

parallel translation corpora, and Al-Onaizan *et al.* (1999) used cognate information to improve statistical machine translation.

Finally, transduction induces lesser sparsity in the model as compared to translation, because the hypothesis space is restricted to only functions that map words to their possible cognates. For closely related languages, the added reduction in sparsity also comes from the fact that there are consistent variations between how a source word transduces to its cognate target word. Hence, transduction is a task that performs better with low-sized training data, than translation using a similarly complex model would. This reduced sparsity enables transduction models to perform well on OOV words.

The ensuing section provides background about NMT systems and the manner in which we have adapted them to our task.

## 1.2 *Neural Machine Translation*

Neural Machine Translation (NMT) has so far been able to deliver promising results in the field of large-scale translation tasks such as Chinese-to-English (Tu *et al.* 2017) and English-to-French (Chen and Wu 2017). The initial application of NMTs was in using them as a sub-component of the PBMT system such as for generating the conditional probabilities of phrase pairs (Cho *et al.*), to be fed as a feature for the PBMT, or for re-ranking the  $n$ -best hypothesis produced by the aforementioned system (Kalchbrenner and Blunsom 2013), (Sutskever *et al.* 2014a) to produce state-of-the-art results. One most appealing feature of NMTs is that they are largely memory efficient. Unlike PBMT systems, an NMT system does not require keeping track of phrase pairs or language models. Additionally, the work of Bentivogli *et al.* (2016) pointed out that NMTs offer a range of other superior attributes including:

- generation of outputs that require considerably lower post-edit efforts
- better translation quality in terms of BLEU score, Translation Edit Rate, and performing well on longer sentences
- lesser errors in terms of morphology and word order

Most of the NMT systems today make use of the encoder-decoder based approach, e.g., (Forcada and Neco 1997); (Cho *et al.*); (Kalchbrenner and Blunsom 2013); (Sutskever *et al.* 2014a), which consists

of two recurrent neural networks (or, their variants). The first encodes a variable-length source token  $x$  into a fixed length vector and the second decodes the vector into a variable-length target token  $y$ . NMT approaches were initially designed to work at the word-level and translate sentences. However, noting the encouraging results of adapting NMTs to character-level translation by Vilar *et al.* (2007), we adapt NMTs to our character-level transduction. Figure 1 shows the architecture of such an encoder-decoder based NMT system performing character-level transduction. The model is trained over a parallel corpus to learn the maximum conditional probability of  $y$  given  $x$ , i.e.,  $\text{argmax}_y p(y | x)$ . Once trained, the model can then be used to generate the corresponding transduction for a given source word.

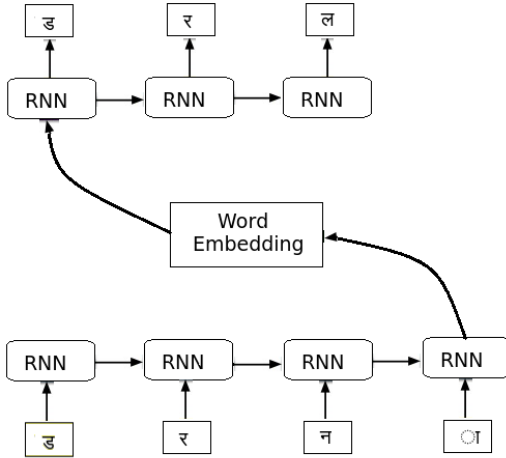

Figure 1: Encoder-Decoder Network architecture showing transduction for the Hindi word [darnA] to its Bhojpuri translation [darala]

However, the performance of NMT degrades largely in the case of longer length sequences (words, in our case) due to the vanishing gradient problem (Bengio *et al.* 1994) arising during the training of the underlying RNN. So far, the use of an attention mechanism, as stated by Bahdanau *et al.* (2014), Luong *et al.* (2015), Vinyals *et al.* (2015) and Yang *et al.* (2016) has been the most plausible solution to

the aforementioned problem for RNNs and its variants. The concept of ‘attention’ takes into account the fact that in the task of translation, different tokens in a sequence are differentially informative, with the information carried by them being highly context dependent. Thus, for predicting each corresponding token, the model looks at the current context of the source token that is relevant to predicting the target token.

### 1.3 *A Concise Introduction to Our Work*

We adapt NMT models to perform ‘transduction’ of a Hindi word to a Bhojpuri word. These word-transduction models work with characters as the fundamental units. They are trained on Hindi-Bhojpuri cognate pairs. This task is important because it helps to solve the OOV problem in larger downstream tasks, the most prominent example of which, is the machine translation for low resource languages. To improve machine translation of Hindi to Bhojpuri, we first identify OOV words in Hindi texts and then use our model to transduce them to their Bhojpuri counterparts. All other words are translated, and not transduced. Using such separate treatment of OOV words, we obtain improvements upon BLEU score with respect to the originally translated texts. The section on Related Work (Section 7) elaborates previous approaches to transduction and the OOV problem.

## 2 Methodology

We run experiments on four different benchmark encoder-decoder networks, namely:

- a simple sequence-to-sequence model (Cho *et al.*) – abbreviated as ‘**seq2seq**’
- the alignment method (Bahdanau *et al.* 2014) incorporated to the seq2seq model – abbreviated as ‘**AM**’
- the Hierarchical Attention Network (Yang *et al.* 2016) incorporated to the seq2seq model – abbreviated as ‘**HAN**’
- the Transformer Network (Vaswani *et al.* 2017) solely based on attention – abbreviated as ‘**TN**’

In the traditional RNN Encoder-Decoder model (Cho *et al.*) –



seq2seq, we incorporate a ‘peek’ at the context vector at every time step. However, the model performed poorly on this translation task, showing a rise in validation accuracy during early training epochs (<6) and maintaining this constantly across all training epochs.

## 2.1 *Character Embeddings*

We introduce a novel pre-trained character-level embedding for Devanagari script, derived from the 300 dimensional Hindi fastText embeddings. We choose the fastText word embedding over other benchmark embeddings since they are obtained using the skip-gram model (Bojanowski *et al.* 2017), thus preserving the sub-word information by representing each word as a bag of character  $n$ -grams. However, due to non-availability of existing pre-trained character vectors for Hindi, we obtain these from existing word embeddings for Hindi<sup>4</sup>. A character pre-training is obtained by averaging over all word vectors of words in which the character occurs, weighted by the number of times it occurs in each word. We propose this method of pre-training character embeddings as it allows us to circumvent the need for extensive training and computational resources required for pre-training character embeddings on a large Hindi monolingual corpus from scratch. Further, we observe that using the FastText skip-gram embeddings provide highly consistent results in comparison to using GloVe or word2vec character-adaptations over monolingual Hindi corpora.

Our experiments show that the use of such pre-trained embeddings results in a gain of 7.5 BLEU points over the present state-of-the-art method (Sharma and Singh 2017) for word transduction. We use the standard WX notation (Gupta *et al.* 2010) to represent Devanagari letters.

Section 2.2, Section 2.3 and Section 2.4 describe the models - AM, HAN and TN - in detail. Since the seq2seq model (Cho *et al.*) is fairly common and widely used for a number of tasks, we omit describing it in detail.

---

<sup>4</sup><https://github.com/facebookresearch/fastText/blob/master/pretrained-vectors.md>

2.2

Alignment Model (AM)

As shown in Figure 2, the alignment model (AM) proposed by Bahdanau *et al.* (2014) facilitates searching through the source sequence during the decoding phase using a unique context vector for each token. Specifically, given a translation  $y_i$  and the source token  $\mathbf{x}$ , the decoder decomposes the conditional probability over all the previously predicted tokens ( $y_1, \dots, y_{i-1}$ ) as:

$$p(y_i | y_1, \dots, y_{i-1}, \mathbf{x}) = g(y_{i-1}, s_i, c_i) \tag{1}$$

where,  $s_i$  is the hidden state of the decoder model computed for time  $i$ ,  $c_i$  is the distinct context vector for each target token  $y_i$  and  $g$  is a non-linear function that outputs the probability of  $y_i$  being the correct translation at time  $i$ .

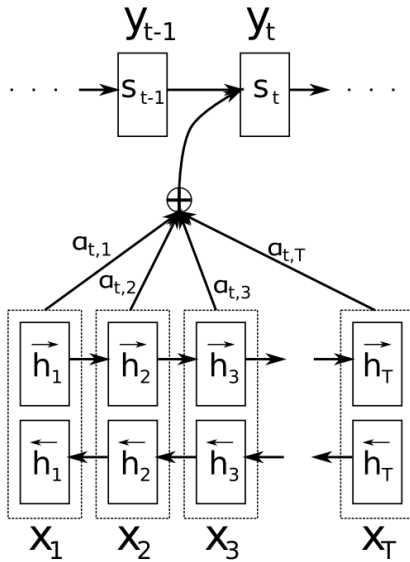

Figure 2: Schematic illustration of the Alignment model adapted from Bahdanau *et al.* (2014)

In addition to the use of unique context vector for each decoding time step, the model takes into account that all the hidden states

computed so far to contribute to the context vector  $c_i$  with weight  $\alpha$ .

$$c_i = \sum_{j=1}^{T_x} \alpha_{ij} h_j \quad (2)$$

$\alpha$  thus serves as a normalized importance weight, measuring the degree of importance of the context tokens around position  $j$  in predicting the translation of the current source token at the output position  $i$  (see Bahdanau *et al.* (2014)). Figure 3 shows the architecture of the encoder-decoder network incorporating the alignment-based attention decoder.

### 2.3 Hierarchical Attention Network (HAN)

Proposed by Yang *et al.* (2016), Hierarchical attention networks (HAN) exploit the hierarchical nature of documents (i.e., characters form words, words form sentences and sentences form a document) and are comprised of two levels of attention mechanisms (Bahdanau *et al.* 2014); (Lai *et al.* 2015)) – the first at the word level while the other at the sentence level. In our case, the former attention can be thought of being effective at the character level, while the latter at the word level, thus allowing the model (Figure 3) to discover the amount of attention required to be paid to the individual characters and words to form a character-level transduction.

### 2.4 Self-attentional Transformer Network (TN)

The Transformer Network (Vaswani *et al.* 2017) consists of an encoder made up of a stack of six identical layers. Each layer further consists of two sub-layers: a *multi-head self-attention* and a simple *position-wise* fully connected feed-forward network. The decoder too has a similar architecture except an additional sub-layer performing multi-head attention over the output of the encoder stack. Both the encoder and the decoder unit employ a residual connection (He *et al.* 2016) in between their respective sub-layers, followed by layer normalization (Ba *et al.* 2016).

As shown in Figure 4, the *positional embeddings* serve to make the representation at time step  $i$  independent from the other time steps. The *multi-head attention* layer serves to replace recurrent dependencies by repeatedly applying self-attention over the same inputs using

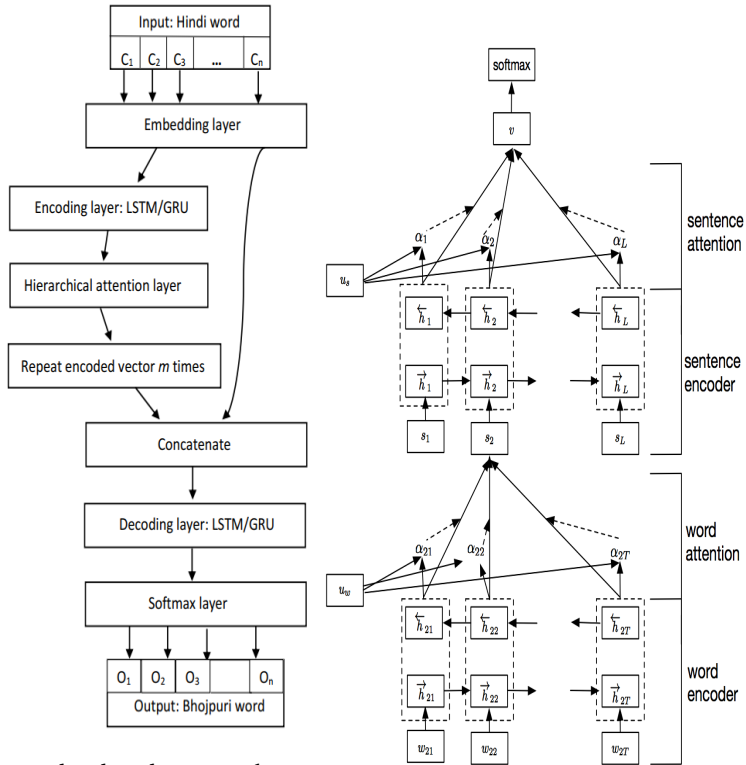

(a) Encoder-decoder network architecture with HAN:  $n$  and  $m$  denote the number of characters in input and output words respectively. (b) Schematic illustration of the HAN framework adapted from re- Yang *et al.* (2016).

Figure 3: Hierarchical Attention Network and its incorporation to our model.

separate parameters (attention heads) followed by combining the results. This combination acts as an alternative to applying single pass of attention with more parameters so that the model can easily learn to attend to different types of relevant information in parallel with each head. In other words, the decoder can now use multiple encoder-attention mechanisms in each of its layers resulting in a significantly faster training than architectures based on recurrent or convolutional layers. Inspired by the recently achieved state-of-the-art results on

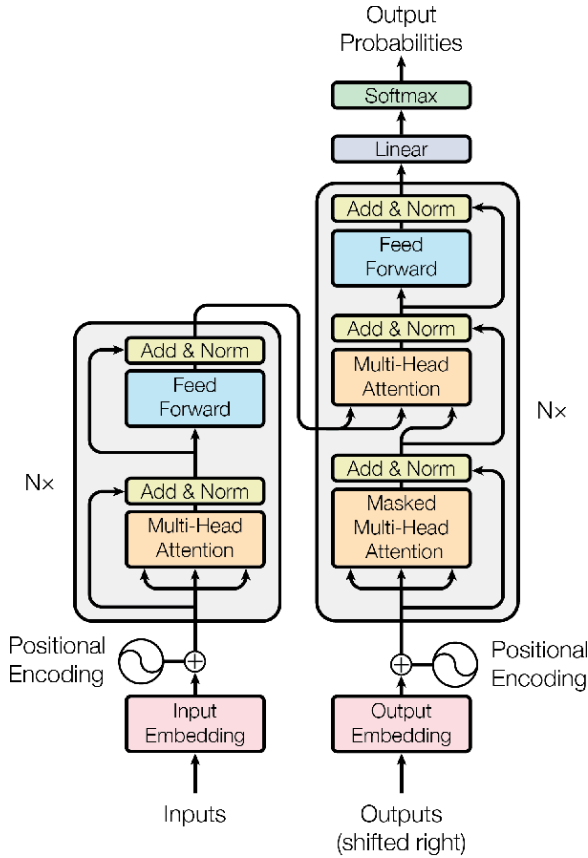

Figure 4: The Transformer architecture as described in and adapted from (Vaswani *et al.* 2017)

both WMT2014 English-German and WMT2014 English-French translation tasks, we use the Transformer Network in our task, and quite intuitively, by adapting it to look at words as sequences of character tokens.

### 3 Experiments

For the AM and HAN models, we consider various parameters while training, such as LSTM/GRU as encoding/decoding units, sequence chunking and batch sizes, optimization methods, regularization, and

we report that there is a huge variance in the transduction performance depending on the combinations of the parameters used (Appendix A). As regards the TN model, due to computational and implementation limitations, we could not perform such an extensive hyperparameter search. Nevertheless, we take care of the basic parameter settings (as suggested in Popel and Bojar (2018)) by limiting our model to single GPU BASE, setting batch size to 512 (i.e., the largest such size avoiding BLEU score degradations and out-of-memory errors), maximum sequence length to the length of the longest token in the parallel corpus followed by a final averaging of the last 6 training checkpoints while leaving the learning rate and the number of warm up steps at their default values. Finally, the extracted character embeddings are used to train the AM and HAN models while the TN model is left void of these mainly because of its inherent dependency on segmenting the training tokens into semantically useful sub-tokens which are hard to be reproduced in varying experiments (Popel and Bojar (2018)), and thus cannot be easily assigned such embeddings. We compare the results of the TN model with the best results (among various hyperparameter settings) of the AM and HAN models.

The implementation of the Alignment model (AM) and the Hierarchical attention network (HAN) is based upon Keras-2.0.6 (Chollet et al. 2015) while that for the Transformer Network (TN) is based upon tensorflow-1.4.1 (Abadi et al. 2015) and tensor2tensor-1.4.3<sup>5</sup>. We carry out our experiments on x86\_64 GNU/Linux with 8G memory, using one NVIDIA GeForce 840M with CUDA V8.0.61, and Python 3.5.2+.

### 3.1 Dataset

In order to be able to compare our results with the state-of-art (SOTA) – described in Section 3.3 – we use the same dataset as by SOTA (Sharma and Singh (2017)), which consists of 4220 Hindi-Bhojpuri word cognate pairs chosen from a pre-compiled lexicon of Hindi-Bhojpuri word translations. This dataset was compiled by linguistic experts who are native speakers of both Bhojpuri and Hindi. Cognate pairs were identified from this set using domain expertise by linguistic experts. This method of cognate extraction is in contrast to possibly

---

<sup>5</sup><https://github.com/tensorflow/tensor2tensor>

sub-optimal rule-based and similarity-based approximations, such as those used by Mann and Yarowsky (2001). In summary, the training data has Hindi-Bhojpuri word pairs, each of which comprises a Hindi and Bhojpuri word that have the same meaning, as well as similar pronunciations. We split the dataset into 3:1 ratio for training and testing our models. A validation split of 0.1 was further made on the train set comprising of 3165 word pairs. ***This test is held-out and is used for reporting only the final results. All hyperparameter tuning is done on the validation set. The validation set is not fixed and the training is cross-validated, with a new random validation-set being used at each iteration of tuning.*** Table 1 consolidates these statistics. We perform a random shuffle of the train and validation set prior to each training epoch.

Table 1: Transduction corpus statistics

	Training set	Validation set	Test set
Total number of words	2,849	316	1055
% of words of full dataset	67.5%	7.5%	25%

## 3.2

*Evaluation Measures*

We report the accuracy of each experiment based on the BLEU score and Levenshtein distance based string similarity (SS) measure<sup>6</sup>. After obtaining the optimum hyperparameter set for AM and HAN, we compare the word accuracy (WA) report defined by the percentage of correctly translated words for all the models including the SOTA. SS, WA and BLEU score formulae for two arbitrary strings ‘s1’ and ‘s2’ are given below. These are averaged across the validation/test set and then reported in the tables in ensuing sections. It must be mentioned here that the character n-grams version of BLEU score is used (as used in Denoual and Lepage (2005)), because we are working at the word-level and not the document-level. One reason to use this metric is to be able to compare with state-of-art transduction methods, which use this metric. Further, other popular metrics such as CHRF and TER correlate well with the character n-gram version of BLEU score (as

---

<sup>6</sup><https://pypi.python.org/pypi/python-Levenshtein/0.12.0>

observed by Popović (2015))

$$SS(s1,s2) = (1 - \frac{Levenshtein\ Edit\ Distance(s1,s2)}{len(s1) + len(s2)}) * 100$$

$$WA(s1,s2) = \{1\ if\ s1 == s2 ; 0\ otherwise\}$$

$BLEU(s1,s2)$  : As adapted from Papineni et al. (2002) ,  
to character  $n$ -grams instead of word  $n$ -grams, as used by Denoual and  
Lepage (2005)

### 3.3

#### *State of the Art (SOTA)*

We consider the results of Sharma and Singh (2017) to be state of art. To the best of our knowledge, their work is the only relevant one on Hindi-Bhojpuri transduction or even any form of OOV word handling technique for this language pair. While their work builds upon traditional PBMT approaches, they first convert lexical word representations into phoneme strings followed by the alignment of phonemes in these strings. The word is then segmented into phoneme chunks which thus facilitates the extraction of weighted rewrite rules for these chunks.

*Since the work of Sharma and Singh (2017) extensively compares and contrasts their own work to the related work in transduction, we refrain from such an elaborate comparison, and suggest their work to the reader for more comparisons to other techniques.* Moreover, their work being state-of-art, we believe that it suffices to show improvements on their results to demonstrate improvements over state-of-art.

### 3.4

#### *Common Aspects Across Models*

Our adaptations of each of the models (i.e., seq2seq, AM, HAN and TN) use Bidirectional LSTMs (BLSTM) as encoder-decoder units unless specified otherwise. A detailed analysis of hyperparameter tuning and training aspect for each model can be found in the Appendix section (A). The appendix documents detailed studies behind our decisions on using LSTM vs GRU, sizes of encoding and decoding layers, number of layers, batching, optimization methods, regularization methods and pre-training embeddings for each of the three models. We find that these results may be useful for future work in morphology-related tasks. The results in each table in the Appendix - Section A show the



epoch with least validation loss. We show the epoch (abbreviated as ‘ep’ in the tables) in order to keep track of the convergence speed and the risk of overfitting. The standard optimization method is (unless otherwise mentioned) Adam (Kingma and Ba 2014a) with an initial learning rate of  $10^{-3}$ .

***The input to all these models is the Hindi word and the output is the transduced Bhojpuri word.***

4

## Results

### 4.1 Comparison Between Our Models and the State-of-the-Art Model

Table 2 shows the comparison of the best AM and HAN models (after the hyperparameter search) with that of the results of the standard encoder-decoder model, the TN model and the present state-of-the-art (SOTA) model (Sharma and Singh 2017). The BLEU scores of AM, HAN and TN are higher than that of the phoneme-chunk based model used by Sharma and Singh (2017). While the TN outperforms the SOTA model in terms of word accuracy (WA), the AM and HAN lag behind. The simple seq2seq model performs the worst among all our models, and fails to match up to SOTA.

The TN performs the best due to two main reasons: 1) Residual connections that connect the input character embeddings to the final decoder of the output word: The transduction of a Hindi word can be thought of as making character level edits upon the Hindi word, in the same orthographic space. The residual connections, hence, help in learning these edits by conditioning the final decoder not only on the attention-based representation of the input word but also directly the input word itself. 2) The multi-head attention mechanism of the TN helps to model the dependencies of characters in the input and output words, regardless of their distances from each other. This would otherwise have to be learnt from a restricted fixed-sized representation, which is usually an LSTM.

The simple seq2seq model performs the poorest because, perhaps, the generic architecture is not adapted to the task in any manner, based on knowledge about the linguistic properties between cognate-pairs. This simple architecture fails to capture long-range dependencies for 1) longer words, and 2) words in which the dependencies be-

tween orthographic segments in the source and target word are not very obviously aligned.

The performance improvements of HAN and AM could be attributed to their attention mechanisms that facilitate better capturing of the intricacies of phonetic and orthographic dependencies of cognates. It is interesting to see that the HAN performs worse than the AM, and this might be because of the over-parametrization of HAN. HAN is over-parameterized since it was originally proposed for building a hierarchy over documents where a layer of attention is effected across words in sentences of the document, and another layer is effected across characters in words of sentences. In our case we only deal with individual words, and not documents. This, combined with the fact that we have a small-sized training set, perhaps causes the HAN to overfit the training data and perform poorly on the test set.

An elaborate account of errors made on different word-pair types by each of these models is presented in Section 5. These differences in errors occur due to the differences in the models as expounded above.

#### 4.2 *Gains Over SOTA*

We see from Table 2 that TN performs best across all accuracy metrics. This is our best model and using this model achieve gains over SOTA, of 11.07 BLEU score points (a percentage gain of 13.9%) and a Word Accuracy gain of 11.3% (a percentage gain of 17.5%). The SOTA paper did not provide information of SS scores, and hence we have not made this comparison.

#### 4.3 *Additional Experiments on Hindi-Bengali cognate pairs*

We performed similar experiments as we have done for Hindi-Bhojpuri on another pair of Indian languages - Hindi and Bengali (also called Bangla). We obtained encouraging results on this language pair too, and have elaborated on these experiments with results in the Appendix, in Section B.

### 5 Error Analysis

We analyse the outputs of each model to study a pattern in the most common errors made by each of them. We identify six types of orthographic and lexical errors, and four types of errors related to overall

Table 2: Comparison of evaluation metrics between encoder-decoder without attention (seq2seq), alignment model (AM), hierarchical attention network(HAN), Transformer Network (TN) and the phoneme-chunk based word transduction model (SOTA)

Metrics	seq2seq	AM	HAN	TN	SOTA
BLEU	51.46	87.32	83.14	<b>90.89</b>	79.82
SS	55.12	85.56	80.89	<b>90.23</b>	-
WA	11.30%	61.30%	54.23%	<b>75.71%</b>	64.41%

translation quality for a word. While orthographic errors are motivated with respect to the types of graphemes generated by character patterns, quality-related errors focus on overall aspects of the transduction being close to the correct translation.

*A note on English representations of Hindi words used:* Throughout this paper, we have used the WX notation (Gupta *et al.* 2010) to represent Hindi and Bhojpuri characters in English, for the benefit of readers who are not familiar with the Devanagari script. A ready reference table of the WX notation can be found in its Wikipedia page<sup>7</sup>.

## 5.1 Orthographic and Lexical Errors

### 5.1.1 Halant

Halants refer to diacritics used to signify the lack of an inherent vowel in written Devanagari scripts. In Devanagari, the halant is represented by a diacritic below the consonant it applies on (e.g., ळ), while it is represented by not using any vowel after the consonant it applies on in the WX notation (e.g., ळ is represented as simply 'x'). In most of the cases, halants are preserved during translation of Hindi to Bhojpuri words, except few (e.g. [praWA] becomes [paraWA]). We study the capability of each model to handle the translation of halants. While HAN and TN perform reasonably well at translating halants, AM tends to replace the character possessing halant with some ligature of it combined with a neighboring character, e.g. [wka] in [pawkAranana] and [wwa] in [paviwwA].

<sup>7</sup>[https://en.wikipedia.org/wiki/WX\\_notation](https://en.wikipedia.org/wiki/WX_notation)

Table 3: Handling halant

Hindi	Bhojpuri (correct)	AM	HAN	TN
(praWA)	(paraWA)	(pararA)	(paraWA)	(paraWA)
(paviwrawA)	(paviwrawA)	(paviwwA)	(paviwraw)	(paviwrawA)
(pawrakAroM)	(pawrakArana)	(pawkAranana)	(pawrA)	(pawrakArana)

### 5.1.2 Handling vowels

Vowels play an important role in the translation words of Hindi to its closely related languages. Our investigations show that TN performs the worst in recognising appropriate vowel translations for vowels used in Hindi words. While the outputs of HAN are the most reasonable ones after the post-processing step, the AM model performs moderately well in learning correct vowel translations.

Table 4: Handling vowels

Hindi	Bhojpuri (correct)	AM	HAN	TN
(AnA)	(AiIA)	(ayanA)	(AnA)	(ayana)
(GumAnA)	(GumaAvala)	(GuhAvala)	(GumaAvala)	(GomaAvala)
(mOsl)	(mausI)	(mausI)	(mausI)	(mausI)

### 5.1.3 Handling Anusvāra

An anusvāra is a diacritic used in a variety of written Indic scripts to denote a pure nasal sound. Moreover, Anusvāra appears only in front of consonants and has no existence in Bhojpuri scripts. In Devanagari, the anusvāra is represented by the dot (.), while it is represented by the letter 'M' in the WX notation. The two general patterns for translation of anusvāra are:

1. replacing them by adding an extra ' [na]' in front of the consonant, e.g. [leKoM] -> [leKana]
2. completely removing them, e.g. [BeMta] -> [Beta]

Our study shows that all three models get confused at choosing the correct rule and generally end up choosing the former one. Comparatively, the AM based model performs better than the other two.

Table 5: Handling anusvāra

Hindi	Bhojpuri (correct)	AM	HAN	TN
(kaTinAyioM)	(kaTinAyiana)	(kaTinAyiana)	(kaTinAyiana)	(kaTinAyiana)
(leKoM)	(leKana)	(leKana)	(leKana)	(leKana)
(BeMta)	(Beta)	(Benta)	(Ben)	(Benta)

#### 5.1.4 Handling Conjuncts for [kRa] and [jFa]

Conjuncts are formed when successive consonants, lacking a vowel in between them, physically join together. The conjuncts for [kRa] and [jFa] are special cases in that they are not clearly derived from the letters making up their components, i.e., conjunct for [kRa] it is [k] + [Ra] and for [jFa] it is [j] + [Fa]. The rules for translation of such conjuncts from Hindi to Bhojpuri are difficult to model (e.g. in the translation [vqkRa] to [biriCa], [kRa] becomes [Ca], while it remains as [kRa] in other cases) and therefore, we explore the capability of the models in learning such translations. Our study shows that while the translation for [kRa] is easily learned by the models in most cases, the translation for [jFa] often results in ambiguity. Overall, TN performs the best in learning such translations while AM performs the worst.

Table 6: Handling conjuncts for [kRa] and [jFa]

Hindi	Bhojpuri (correct)	AM	HAN	TN
(barEkRA)	(baraikRA)	(barabakDa)	(baraikRA)	(baraikRA)
(avEjFAnika)	(abEjFAnika)	(avEjajAnika)	(abEjianika)	(avEjFAnika)
(vqkRa)	(biriCa)	(bakC)	(bikRiRa)	(biriCa)

#### 5.1.5 Handling the ā-diacritic of [ra] . e.g. [rva], [rvA], [rspa]

[ra] has a special diacritic that takes the form of a curved upward dash above the preceding consonants. While translating the Hindi words containing such diacritics to their Bhojpuri counterparts, the diacritic is either replaced completely by or simply kept unchanged. Our results show that the AM model learns to preserve the diacritic as it is in most

of the cases while the HAN and the TN model generally replace it by a complete [ra].

Table 7: Handling the ā-diacritic of [ra]

Hindi	Bhojpuri (correct)	AM	HAN	TN
(ahiMsApUrvaka)	(ahinsApUrvaka)	(ahinsApUrvan)	(ahinsApUrasaka)	(ahinsApravaka)
(nAcapArtI)	(nAcpaArati)	(nAcapArta)	(nAcapArapa)	(nAcapArI)
(ParnIcara)	(ParanIcara)	(ParIcara)	(Pari)	(ParanIcara)

### 5.1.6 Handling Hrasva and Deergha Varna (Short and Long Vowels)

Most Hindi words have the same long and short vowels appended to the consonants in their respective Bhojpuri counterparts (words such as [xUsarA] can be treated as exceptions). We observe that for words preserving the nature of vowels (long or short), the AM and HAN based models perform better than that of the TN model while all the models fail to learn the cases where the nature of vowels (long or short) is switched upon translation. Interestingly, the TN model actually recognizes words in which the long vowel has to be switched to the short vowel and vice versa (we deduce this because it does not preserve the long/short nature in these cases) but it does not perform the switch correctly, and instead shows ambiguous behavior on predictions.

Table 8: Handling hrasva and dirgh varna

Hindi	Bhojpuri (correct)	AM	HAN	TN
[hima]	[hima]	[hima]	[hima]	[hIma]
[dUsrA]	[dusar]	[dUsar]	[dUsar]	[dosar]
[GI]	[GIva]	[GI]	[GI]	[GI]

## 5.2 Transduction-based Properties

### 5.2.1 Performance on Long Words

We consider long words as those exceeding six characters in length. We explore that while the translation quality of all the models degrade with increase in length of the words, the AM based architecture is able

to maintain most sensible outputs, followed by the TN and the HAN based model.

Table 9: Performance on Long words

Hindi	Bhojpuri (correct)	AM	HAN	TN
(vidyArWiyom)	(vidyAraWiyana)	(vidyArWayana)	(vidyArasiyana)	(vidyAriyana)
(surakRAkarmiyom)	(sorakRAkaramiyana)	(surakFAkaranana)	(surakRAkairiyana)	(surakRArana)
(haWiyArabanda)	(haWiyArabanda)	(haWiyArabanda)	(haWiyArabanda)	(haWiyArabda)

### 5.2.2 Identical Transduction

For words in Hindi having the same Bhojpuri transduction, we observe that the HAN based model gives the best results after post-processing. The TN model fails in cases of longer words while the performance of the AM based model deteriorates for shorter words as well as vowels.

Table 10: Performance on identical translations

Hindi	Bhojpuri (correct)	AM	HAN	TN
(mOlavI)	(mOlavI)	(maubi)	(maulavI)	(maulavI)
(Jata)	(Jata)	(JaCata)	(Jatatata), (Jata)	(Jata)
(haWiyArabanda)	(haWiyArabanda)	(haWiyArabanda)	(haWiyArabanda)	(haWiyArabda)

### 5.2.3 Sensible, yet Erroneous Translations

We individually study the translations made by each model which sound legitimate when compared to the translations of other similar words but are actually wrong. For example, while the Bhojpuri translation for [BEyA] is [BaiyA] ([BE] replaced by [Bai]), the translation for [kEmarA] does not follow such approach, whereby the character ‘[kE]’ remains preserved. We observe that each model has its own types of erroneous translations due to such ambiguities.

### 5.2.4 Phonetically invalid translations

These are predicted transductions which do not follow the necessary phonetic rules in order to be pronounced. We study the type of such words individually for each model, our findings suggest that the TN performs excellently in learning such rules since, we did not notice

Table 11: Performance on sensible yet erroneous translations

Model	Hindi	Bhojpuri (correct)	Predicted
AM	[wanmayawA]	[wanmayawA]	[wanamayawA]
AM	[kEmerA]	[kEmerA]	[kaimerA]
HAN	[warabUjA]	[warabUjA]	[warabUja]
HAN	[yamunA]	[yamunA]	[jamun]
TN	[KilAdI]	[KelAdI]	[KelAdI]
TN	[upkaraNa]	[upakaraNa]	[opkaraNa]

any such instance of unpronounceable words present in the outputs of TN. Overall, HAN produced the most unpronounceable translations.

Table 12: Phonetically invalid translations: For invalid predictions, a closest approximation of the WX notation is given

Model	Hindi	Bhojpuri (correct)	Predicted
AM AM	(XarmanwaraNa)	(Xaramanwarana)	(Xarmaani)
AM AM	(surakRAkarmIyoM)	(surakRAkaramIyana)	(surakRAkairIyana)
AM AM	(varjila)	(varajila)	(baraimi)
HAN HAN	(kuMjI)	(kunjI)	(kuMI)
HAN HAN	(avEjFAnika)	(abEjFAnika)	(avEjajAnika)

## 6 Improvements on Hindi-Bhojpuri Machine Translation (MT)

This section talks of the improvements we make on machine translation from Hindi to Bhojpuri. The authors would like to mention two key points here. First, this section stands distinguished from the rest of the paper in that the methods and results discussed till now hold for word-to-word transduction. In contrast, we now depict how such transductions can be used to improve the accuracy of a machine translation system. Second, we must mention that to the best of our knowledge, no prior machine translation systems have been trained on a



Hindi-Bhojpuri parallel corpus, simply because such a corpus does not exist.

For our purposes, we build an artificial parallel corpus in the following manner. We first scrape 4 Bhojpuri blogsites for Bhojpuri sentences : Anjoria <sup>8</sup>, TatkaKhabar<sup>9</sup>, Bhojpuri Manthan<sup>10</sup> and Bhojpuri Sahitya Sarita<sup>11</sup>. From these, we collect a set of approximately 40,000 Bhojpuri sentences. We then follow a two-step process for obtaining Hindi translations of these sentences using the Google Translation API. Since the API does not offer Bhojpuri as a source language, we first use the Hindi-English API for translating the Bhojpuri sentences to English (as an intermediate language). We then translate these English sentences to Hindi using the Hindi-English API. Although this process gives us noisy translations between Bhojpuri and Hindi, this method is based upon the hypotheses that: 1) this is the best available solution in the absence of Hindi-Bhojpuri parallel corpora, let alone a pre-trained Hindi-Bhojpuri translation system 2) Bhojpuri stands close enough to Hindi so as to ensure its linguistic properties remain preserved satisfactorily throughout the intermediate processing. Also, the choice of English as an intermediate language is based on the fact that it gives the best BLEU scores when Hindi is fixed as the other language in the translation pair. At the time of writing this work, there is no Bhojpuri-Hindi API (or Hindi-Bhojpuri machine translation system), while trivially translating using the Hindi-Hindi API does not work as the API simply copies the inputs to outputs.

***For reporting the machine translation results, we use the standard document-level BLEU score as suggested by Papineni et al. (2002).***

For the held-out test set, we curated 1000 sentences for which ground truth translations were manually obtained from experts, and not artificially generated. Statistics on training and test sentences can be found in Table 13.

We train a Bi-LSTM based encoder-decoder network (500 units) with Luong attention, as described in Luong *et al.* (2015) (we use OpenNMT's global attention implementation) on the training set for

---

<sup>8</sup><https://www.anjoria.com/>

<sup>9</sup><http://khabar.anjoria.com/>

<sup>10</sup><http://bhojpurimanthan.com/>

<sup>11</sup><http://www.abhivarta.co.in/>

Table 13: Machine Translation corpus statistics

	Training set	Test set
Number of sentences	40,000	1,000
Total number of tokens	8,12,070	19,689
Number of unique tokens	20,551	620

Hindi-Bhojpuri translation. The model thus trained resulted to a BLEU score of around 7.1 on the test set, which is not surprising given the method of training. With this as the baseline, we make corrections to this model’s output. We first align the Hindi sentence and its Bhojpuri translation, by aligning pairs of source-target words based on their pairwise weights in the attention matrix. Following this, we identify OOV Hindi words using a simple dictionary-based approach as has been suggested by Bahdanau *et al.* (2014). We use a shortlist of 15k most common words in Hindi, obtained from the Hindi Wikipedia monolingual corpus, and treat **all other words** as OOV. We experiment with 5k, 10k, 15k, and 20k most common words, and find the 15k-shortlist to provide best BLEU score improvements. We then replace the translation (as obtained by the alignments using the attention matrix) of each OOV word with its corresponding transduction generated by our word transduction model. Replacing the translation of OOV words with that of their transductions leads to an improvement of 6.3 points in the BLEU score, which is substantial considering that we are translating to a low-resource language. We obtain a BLEU score of 13.4 with such a basic translation set-up followed by simple correction of OOV translations using transductions.

More importantly, the improvement in the MT BLEU score shows that even though the task of transduction is a focused one, it generalizes well to OOV Hindi words that are not part of a Hindi-Bhojpuri cognate pair. This stands as an important aspect of our work. Our transduction model, despite being trained on a dataset that is constrained to cognate pairs, lends reasonable improvements to the highly generalized machine translation task by exploiting the closeness of Hindi and Bhojpuri.

While the Introduction sections mention a number of related works, this section mentions a few that have not been covered, but provide context and insight to our work. A number of methods have been proposed to handle the OOV problems in machine translation of unknown or rare words. Bahdanau *et al.* (2014) simply use a shortlist of 30k most frequent words and map all other less frequent words to an UNK (unknown) token. Sutskever *et al.* (2014b) use a vocabulary of 80k words and achieve better performance. However, any UNK-based approach is problematic because in larger sentences, UNK tokens heavily degrade performance (Cho *et al.* (2014)). Jean *et al.* (2014) make model specific improvements, using a smaller batch for normalization and including only frequent words in the denominator of this normalization. They fall back to other translation and alignment models to replace UNK tokens.

Other approaches to handle OOV words include using a back-off dictionary look-up (Jean *et al.* (2014), Luong *et al.* (2014)) but as observed by Sennrich *et al.* (2015), these techniques make impractical assumptions. One such assumption is a 1-to-1 source-target word correspondence, which is not true for obvious reasons. Sennrich *et al.* (2015), in turn use a Byte Pair Encoding for transduction, which is very similar to character-level encoding of sequences as strings of characters.

We also borrow ideas from previous approaches that have used cognates. Simard *et al.* (1993) use cognates to align sentences in a parallel corpus and report 97.6% accuracy on the alignments obtained, when compared to reference alignments. Mann and Yarowsky (2001) use cognates extracted based on edit distances for inducing translation lexicons based on transduction models. Scannell (2006) present a detailed study on translation of a closely related language pair, Irish-Scottish Gaelic. They learn transfer rules based on alignment of cognate pairs, and use these rules to generate transductions on new words. They use a fine-grained cognate extraction method, by first editing Scottish words to ‘seem like’ Gaelic words, and then using edit string similarity on the new word pairs and choosing only close words with the additional constraint that both words in the pair should share a common English translation. However since we use linguistic experts

to extract cognates from our dataset, we do not need to encode string similarity measures explicitly to extract cognates.

We borrow insights from character-level machine transliteration and translation models that have been proposed in the past, as transduction can be viewed as a variation of transliteration (which is, in turn, viewed as character-level translation in many works), working within the same script. Alternatively, it can also be thought of simply as a translation of ‘true friend’ cognates.

Vilar *et al.* (2007) work on transliteration at the character-level (and translation at the word-level), to build a ‘combined system’ that shows increasing gains over just the word-level system, as the corpus size grows smaller. This is because the character-level transliteration takes into account the added morphological information such as base forms and affixes. Tiedemann (2012) experimented with different types of alignment methods and learning models, and showed that in each type of method, there exists at least one character-level model that performs better than word-level models (in the case of closely related language pairs). Denoual and Lepage (2006) also show merits of using characters as appropriate translations, and highlight issues with making assumptions about words being natural units for the task. Finch and Sumita (2009) view transliteration as a character-level machine translation, and use Phrase-Based SMT for bidirectionally encoding source sequences. They observe the lack of necessity to model phonetics of source or target language, due to the use of direct transformations.

*We would like to flag one point of difference between some of the related work on cognates and ours: it is that we do not perform context-sensitive transduction simply due to lack of annotated data that is context-sensitive.*

We propose a character-level transduction of OOV words between a pair of closely related languages, out of which at least one is a low-resource language. Word transduction aims to predict the orthographic form of the word in the target language, given the word in the source language. We restrict the training space to a set of cognates, since in the case of closely-related languages, a cognate can be a good approximation to a translation, if not the translation it-

self. We present different models for the same, each of which performs well on handling certain types of grapheme transformations, while performing poorly on other types. Overall, the TN model gives the best performance. Our models outperform the current state of art for Hindi-Bhojpuri transduction. We suggest a two-step procedure to show how improvements to an MT system can be made by: 1) Identifying the need to handle OOV words separately and 2) Transducing them to their target equivalents, instead of translating them.

In the process, we also propose a primitive yet useful MT method using Google Translate APIs for a pair of languages which has no known MT system. In the future, we would like to test our models on more closely related language pairs. Further, we would like to build a state-of-art MT pipeline for low resource languages, which incorporates our method to handle OOV words.

The code we used to train and evaluate our models is available at <https://github.com/Saurav0074/Hindi-Bhojpuri-Word-Transduction>.

## References

Martín ABADI, Ashish AGARWAL, Paul BARHAM, Eugene BREVDO, Zhifeng CHEN, Craig CITRO, Greg S. CORRADO, Andy DAVIS, Jeffrey DEAN, Matthieu DEVIN, Sanjay GHEMAWAT, Ian GOODFELLOW, Andrew HARP, Geoffrey IRVING, Michael ISARD, Yangqing JIA, Rafal JOZEFOWICZ, Lukasz KAISER, Manjunath KUDLUR, Josh LEVENBERG, Dan MANÉ, Rajat MONGA, Sherry MOORE, Derek MURRAY, Chris OLAH, Mike SCHUSTER, Jonathon SHLENS, Benoit STEINER, Ilya SUTSKEVER, Kunal TALWAR, Paul TUCKER, Vincent VANHOUCKE, Vijay VASUDEVAN, Fernanda VIÉGAS, Oriol VINYALS, Pete WARDEN, Martin WATTENBERG, Martin WICKE, Yuan YU, and Xiaoqiang ZHENG (2015), TensorFlow: Large-Scale Machine Learning on Heterogeneous Systems, URL <https://www.tensorflow.org/>, software available from tensorflow.org.

Yaser AL-ONAIKAN, Jan CURIN, Michael JAHR, Kevin KNIGHT, John LAFFERTY, Dan MELAMED, Franz-Josef OCH, David PURDY, Noah A SMITH, and David YAROWSKY (1999), Statistical machine translation, in *Final Report, JHU Summer Workshop*, volume 30.

Jimmy BA, Ryan KIROS, and Geoffrey E. HINTON (2016), Layer Normalization, *CoRR*, abs/1607.06450.

Dzmitry BAHDANAU, Kyunghyun CHO, and Yoshua BENGIO (2014), Neural Machine Translation by Jointly Learning to Align and Translate, *CoRR*,

abs/1409.0473.

Yoshua BENGIO, Patrice Y. SIMARD, and Paolo FRASCONI (1994), Learning long-term dependencies with gradient descent is difficult, *IEEE transactions on neural networks*, 5 2:157–66.

Luisa BENTIVOGLI, Arianna BISAZZA, Mauro CETTOLO, and Marcello FEDERICO (2016), Neural versus Phrase-Based Machine Translation Quality: a Case Study, in *EMNLP*.

Piotr BOJANOWSKI, Edouard GRAVE, Armand JOULIN, and Tomas MIKOLOV (2017), Enriching Word Vectors with Subword Information, *TACL*, 5:135–146.

Qiming CHEN and Ren WU (2017), CNN Is All You Need.

David CHIANG (2005), A Hierarchical Phrase-based Model for Statistical Machine Translation, in *Proceedings of the 43rd Annual Meeting on Association for Computational Linguistics*, ACL '05, pp. 263–270, Association for Computational Linguistics, Stroudsburg, PA, USA, doi:10.3115/1219840.1219873, URL <https://doi.org/10.3115/1219840.1219873>.

Kyunghyun CHO, Bart VAN MERRIËNBOER, Caglar GULCEHRE, Dzmitry BAHDANAU, Fethi BOUGARES, Holger SCHWENK, and Yoshua BENGIO (2014), Learning phrase representations using RNN encoder-decoder for statistical machine translation, *arXiv preprint arXiv:1406.1078*.

Kyunghyun CHO, Bart VAN MERRIENBOER, and year = 2014 ÇAĞLAR GÜLÇEHRE AND DZMITRY BAHDANAU AND FETHI BOUGARES AND HOLGER SCHWENK AND YOSHUA BENGIO, booktitle = EMNLP (), Learning Phrase Representations using RNN Encoder-Decoder for Statistical Machine Translation.

François CHOLLET *et al.* (2015), Keras, <https://github.com/keras-team/keras>.

Monojit CHOUDHURY (2003), Rule-based grapheme to phoneme mapping for hindi speech synthesis, in *90th Indian Science Congress of the International Speech Communication Association (ISCA)*, Bangalore, India.

Junyoung CHUNG and year = 2014 volume = abs/1412.3555 ÇAĞLAR GÜLÇEHRE AND KYUNGHYUN CHO AND YOSHUA BENGIO, journal = CoRR (), Empirical Evaluation of Gated Recurrent Neural Networks on Sequence Modeling.

Etienne DENOUAL and Yves LEPAGE (2005), BLEU in characters: towards automatic MT evaluation in languages without word delimiters, in *Companion Volume to the Proceedings of Conference including Posters/Demos and tutorial abstracts*.

Etienne DENOUAL and Yves LEPAGE (2006), The character as an appropriate unit of processing for non-segmenting languages, in *NLP Annual Meeting*, pp. 731–734.

- John DUCHI, Elad HAZAN, and Yoram SINGER (2011), Adaptive subgradient methods for online learning and stochastic optimization, *Journal of Machine Learning Research*, 12(Jul):2121–2159.
- Andrew FINCH and Eiichiro SUMITA (2009), Transliteration by bidirectional statistical machine translation, in *Proceedings of the 2009 Named Entities Workshop: Shared Task on Transliteration*, pp. 52–56, Association for Computational Linguistics.
- Mikel L. FORCADA and Ramón P. ÑECO (1997), Recursive Hetero-associative Memories for Translation, in *IWANN*.
- Sir George GRIERSON (1928), Linguistic Survey of India, *The Journal of the Royal Asiatic Society of Great Britain and Ireland*, 3:711–718.
- Rohit GUPTA, Pulkit GOYAL, and Sapan DIWAKAR (2010), Transliteration among Indian Languages using WX Notation., in *KONVENS*, pp. 147–150.
- Jan HAJIC (2000), Machine Translation of Very Close Languages, in *ANLP*.
- Stephen José HANSON and Lorien Y PRATT (1989), Comparing biases for minimal network construction with back-propagation, in *Advances in neural information processing systems*, pp. 177–185.
- Kaiming HE, Xiangyu ZHANG, Shaoqing REN, and Jian SUN (2016), Deep Residual Learning for Image Recognition, *2016 IEEE Conference on Computer Vision and Pattern Recognition (CVPR)*, pp. 770–778.
- G HINTON, Nitish SRIVASTAVA, and Kevin SWERSKY (2012a), Rmsprop: Divide the gradient by a running average of its recent magnitude, *Neural networks for machine learning, Coursera lecture 6e*.
- Geoffrey E HINTON, Nitish SRIVASTAVA, Alex KRIZHEVSKY, Ilya SUTSKEVER, and Ruslan R SALAKHUTDINOV (2012b), Improving neural networks by preventing co-adaptation of feature detectors, *arXiv preprint arXiv:1207.0580*.
- Sébastien JEAN, Kyunghyun CHO, Roland MEMISEVIC, and Yoshua BENGIO (2014), On using very large target vocabulary for neural machine translation, *arXiv preprint arXiv:1412.2007*.
- Nal KALCHBRENNER and Phil BLUNSOM (2013), Recurrent Continuous Translation Models, in *EMNLP*.
- Diederik P. KINGMA and Jimmy BA (2014a), Adam: A Method for Stochastic Optimization, *CoRR*, abs/1412.6980.
- Diederik P KINGMA and Jimmy BA (2014b), Adam: A method for stochastic optimization, *arXiv preprint arXiv:1412.6980*.
- Grzegorz KONDRAK, Daniel MARCU, and Kevin KNIGHT (2003), Cognates can improve statistical translation models, in *Proceedings of the 2003 Conference of the North American Chapter of the Association for Computational Linguistics on Human Language Technology: companion volume of the Proceedings of HLT-NAACL*

2003–short papers-Volume 2, pp. 46–48, Association for Computational Linguistics.

Siwei LAI, Liheng XU, Kang LIU, and Jun ZHAO (2015), Recurrent Convolutional Neural Networks for Text Classification, in *AAAI*.

Minh-Thang LUONG, Ilya SUTSKEVER, Quoc V LE, Oriol VINYALS, and Wojciech ZAREMBA (2014), Addressing the rare word problem in neural machine translation, *arXiv preprint arXiv:1410.8206*.

Thang LUONG, Hieu PHAM, and Christopher D. MANNING (2015), Effective Approaches to Attention-based Neural Machine Translation, in *EMNLP*.

B.P. MAHAPATRA, P. PADMANABHA, G.D. MCCONNELL, and V.S. VERMA (1989), *The Written Languages of The World : A Survey of the Degree and Modes of Use*, 1.

Gideon S MANN and David YAROWSKY (2001), Multipath translation lexicon induction via bridge languages, in *Proceedings of the second meeting of the North American Chapter of the Association for Computational Linguistics on Language technologies*, pp. 1–8, Association for Computational Linguistics.

Diwakar MISHRA and Kalika BALI (2011), A Comparative Phonological Study of the Dialects of Hindi, in *ICPhS*.

Preslav NAKOV and Jörg TIEDEMANN (2012), Combining word-level and character-level models for machine translation between closely-related languages, in *Proceedings of the 50th Annual Meeting of the Association for Computational Linguistics: Short Papers-Volume 2*, pp. 301–305, Association for Computational Linguistics.

Yurii NESTEROV (1983), A method of solving a convex programming problem with convergence rate  $O(1/k^2)$ , in *Soviet Mathematics Doklady*, volume 27, pp. 372–376.

Kishore PAPINENI, Salim ROUKOS, Todd WARD, and Wei-Jing ZHU (2002), BLEU: a method for automatic evaluation of machine translation, in *Proceedings of the 40th annual meeting on association for computational linguistics*, pp. 311–318, Association for Computational Linguistics.

Martin POPEL and Ondřej BOJAR (2018), Training Tips for the Transformer Model, *The Prague Bulletin of Mathematical Linguistics*, 110(1):43–70.

Maja POPOVIĆ (2015), chrF: character n-gram F-score for automatic MT evaluation, in *Proceedings of the Tenth Workshop on Statistical Machine Translation*, pp. 392–395.

David E RUMELHART, Geoffrey E HINTON, and Ronald J WILLIAMS (1986), Learning representations by back-propagating errors, *nature*, 323(6088):533.

Kevin P SCANNELL (2006), Machine translation for closely related language pairs, in *Proceedings of the Workshop Strategies for developing machine translation for minority languages*, pp. 103–109, Citeseer.



Rico SENNRICH, Barry HADDOW, and Alexandra BIRCH (2015), Neural machine translation of rare words with subword units, *arXiv preprint arXiv:1508.07909*.

Shashi Kant SHARMA and Anil Kumar SINGH (2017), Word Transduction for Addressing the OOV Problem in Machine Translation for Similar Resource-Scarce Languages, in *FSMNL*.

Michel SIMARD, George F FOSTER, and Pierre ISABELLE (1993), Using cognates to align sentences in bilingual corpora, in *Proceedings of the 1993 conference of the Centre for Advanced Studies on Collaborative research: distributed computing-Volume 2*, pp. 1071–1082, IBM Press.

Smriti SINGH and Vijayanthi M SARMA (2010), Hindi noun inflection and Distributed Morphology, in *Proceedings of the International Conference on Head-Driven Phrase Structure Grammar*, pp. 307–321.

Srishti SINGH and Girish Nath JHA (2015), Statistical Tagger for Bhojpurī (employing Support Vector Machine), *2015 International Conference on Advances in Computing, Communications and Informatics (ICACCI)*, pp. 1524–1529.

Ilya SUTSKEVER, Oriol VINYALS, and Quoc V. LE (2014a), Sequence to Sequence Learning with Neural Networks, in *NIPS*.

Ilya SUTSKEVER, Oriol VINYALS, and Quoc V LE (2014b), Sequence to sequence learning with neural networks, in *Advances in neural information processing systems*, pp. 3104–3112.

Jörg TIEDEMANN (2012), Character-based pivot translation for under-resourced languages and domains, in *Proceedings of the 13th Conference of the European Chapter of the Association for Computational Linguistics*, pp. 141–151, Association for Computational Linguistics.

Robert L. TRAMMELL (1971), The Phonology of the Northern Standard Dialect of Bhojpurī, *Anthropological Linguistics*, 13(4):126–141.

Zhaopeng TU, Yang LIU, Lifeng SHANG, Xiaohua LIU, and Hang LI (2017), Neural Machine Translation with Reconstruction, in *AAAI*.

Ashish VASWANI, Noam SHAZEER, Niki PARMAR, Jakob USZKOREIT, Llion JONES, Aidan N. GOMEZ, Lukasz KAISER, and Illia POLOSUKHIN (2017), Attention is All you Need, in *NIPS*.

David VILAR, Jan-T. PETER, and Hermann NEY (2007), Can We Translate Letters?, in *Proceedings of the Second Workshop on Statistical Machine Translation, StatMT '07*, pp. 33–39, Association for Computational Linguistics, Stroudsburg, PA, USA, URL <http://dl.acm.org/citation.cfm?id=1626355.1626360>.

Oriol VINYALS, Lukasz KAISER, Terry KOO, Slav PETROV, Ilya SUTSKEVER, and Geoffrey E. HINTON (2015), Grammar as a Foreign Language, in *NIPS*.

Andreas S WEIGEND, David E RUMELHART, and Bernardo A HUBERMAN (1991), Generalization by weight-elimination with application to forecasting, in *Advances in neural information processing systems*, pp. 875–882.

Zichao YANG, Diyi YANG, Chris DYER, Xiaodong HE, Alexander J. SMOLA, and Eduard H. HOVY (2016), Hierarchical Attention Networks for Document Classification, in *HLT-NAACL*.

Matthew D ZEILER (2012), ADADELTA: an adaptive learning rate method, *arXiv preprint arXiv:1212.5701*.

Martin ZINKEVICH, Markus WEIMER, Alexander J. SMOLA, and Lihong LI (2010), Parallelized Stochastic Gradient Descent, in *NIPS*.

## Appendices

### A Detailed experiments on different neural structures and hyperparameters for AM and HAN

#### A.1 *Encoding/Decoding Layer Size*

For each experiment, we maintain an equal encoding and decoding layer size. A good thumb rule is to begin with half the size of the embedding vector for each token (i.e., 150 dimensional in our case). We therefore, experiment by varying the layer sizes in the range 60, ..., 100 with an interval of 10. Our experiments show that a hidden layer size of 80 LSTM cells give the optimum BLEU score after fixing the number of encoder-decoder layers as 1-1, batch size as 8, a dropout of 0.2 and the optimizer as Adam (Kingma and Ba 2014b) for both the models.

#### A.2 *LSTM vs GRU*

Table 14 shows performance comparison between using a bidirectional LSTM (BLSTM) and using a bidirectional GRU (BGRU). For AM, we observe that the difference in BLEU score, between using an LSTM and a GRU as the encoding-decoding units, is not significant, while the Levenshtein distance increases by almost 2 points when GRU is used. On the other hand, the performance of the HAN based model degrades significantly on using GRUs. Naturally using GRU as the encoding/decoding unit results in faster convergence of both the models (lesser epochs), because of the presence of lesser weight parameters

to be updated at every epoch. Furthermore, our experiments show that LSTMs outperform GRUs in handling translations of longer words for both the models. The lack of controlled exposure of the memory content (Chung and Çağlar Gülçehre and Kyunghyun Cho and Yoshua Bengio, Cho *et al.* (2014)) in the GRU cell could explain this behavior.

Table 14: Comparison of BLSTM and BGRU as encoding/decoding units: number of encoder-decoder layers = 1-1 and 1-2 for AM and HAN respectively, hidden layer size 80, batch size 8, dropout 0.2, and Adam optimizer

Models	BLSTM			BGRU		
	BLEU	SS	ep	BLEU	SS	ep
AM	<b>86.43</b>	<b>81.23</b>	26	<b>85.94</b>	<b>83.31</b>	21
HAN	83.14	80.89	16	76.15	73.77	16

### A.3 *Number of Layers*

Table 15 shows the effect of varying the depth of the network. We find that the optimum number of encoder and decoder layers for the AM architecture is 1 while the HAN based model delivers optimum BLEU score (83.14) with the depth of encoder and decoder layers being 1 and 2 respectively.

### A.4 *Batching*

Table 16 shows the results of our investigations on the performance of AM and HAN on five different batch sizes, preserving the initial learning rate across all the runs. Our experiments show that a batch size of 8 results in maximum BLEU scores (87.34 and 83.14 respectively) for both the models. The increment in BLEU points while increasing batch size to 8 from 1 can be attributed to the fact that the variance of the stochastic gradient update reduces with the increase in batch size, along with faster progress of the optimization algorithm. However, there seems to be no notable increase in the BLEU score on exceeding the batch size of 8. Also, it can be inferred from Table 3 that the SS metric shows no particular trend with increase in batch size.

Table 15: Comparison of number of layers with layer size fixed to 80 for encoding/decoding layers of both AM and HAN, batch size 8, dropout 0.2, and Adam optimizer

#encoder layers	#decoder layers	AM			HAN		
		BLEU	SS	ep	BLEU	SS	ep
1	1	<b>87.34</b>	<b>83.98</b>	43	76.12	75.09	12
1	2	84.12	81.73	37	<b>83.14</b>	<b>80.89</b>	16
1	3	83.47	80.01	35	78.8	78.03	11
2	1	83.88	80.96	48	74.63	73.14	22
2	2	85.12	82.20	41	75.94	75.5	18

Table 16: Comparison of batch sizes: number of encoder-decoder layers = 1-1 and 1-2 for AM and HAN respectively, hidden layer size 80, dropout 0.2, and Adam optimizer

Batch size	AM			HAN		
	BLEU	SS	ep	BLEU	SS	ep
1	85.52	<b>84.34</b>	24	74.80	73.06	10
4	86.43	81.23	26	78.77	76.23	14
8	<b>87.34</b>	83.98	43	<b>83.14</b>	<b>80.89</b>	16
16	87.05	83.41	61	79.13	78.39	20
20	86.81	82.65	72	79.04	76.64	23

Table 17 shows the comparison of various optimization methods, along with different learning rates for Model 1 and 2. We use Adam (Kingma and Ba 2014b) optimizer with and without learning rate decay, Stochastic Gradient Descent (SGD), SGD with momentum (mom) (Rumelhart *et al.* (1986); Sutskever *et al.* (2014a); Zinkevich *et al.* (2010)), SGD with Nesterov momentum (Nesterov (1983)), RMSprop (Hinton *et al.* (2012a)), Adadelata (Zeiler (2012)), and Adagrad (Duchi *et al.* (2011)). We find that the Adam optimizer with a learning rate of  $1e-3$  performs the best. While the use of decay with SGD boosts its potential, the performance of Adam deteriorates badly when trained with decay of the initial learning rate.

Table 17: Comparison of optimization methods: number of encoder-decoder layers = 1-1 and 1-2 for AM and HAN, respectively, hidden layer size 80, dropout 0.2, batch size 8.

Method	lr	details	AM			HAN		
			BLEU	SS	ep	BLEU	SS	ep
Adam	$10^{-2}$	-	77.35	75.58	17	67.18	64.34	13
	$10^{-3}$	-	<b>86.43</b>	<b>81.23</b>	26	<b>83.14</b>	<b>80.89</b>	16
	$10^{-3}$	decay 0.90	9.68	3.20	33	Model broken		
	$0.5 * 10^{-3}$	-	81.57	79.86	21	71.96	68.10	27
SGD	$10^{-2}$	decay $1e^{-6}$ , Nesterov	76.9	77.99	44	66.61	58.95	33
	$0.5 * 10^{-2}$	decay $1e^{-6}$ , Nesterov	70.6	68.06	24	65.64	57.35	94
	$0.5 * 10^{-2}$	decay $1e^{-6}$	77.29	76.28	48	48.24	57.96	88
	$10^{-3}$	decay $1e^{-6}$ , Nesterov	81.92	80.02	329	74.91	73.08	297
RMSprop	$10^{-3}$	-	79.88	78.89	38	60.12	58.04	16
Adagrad	$10^{-2}$	-	75.71	77.9	386	49.05	56.52	278
	$10^{-3}$	-	53.78	25.18	418	36.44	43.19	463
Adadelata	0.5	decay 0.9	Model broken			12.52	2.07	83
	1.0	decay 0.9	Model broken			Model broken		
	1.0	decay 0.95	Model broken			Model broken		

Out of all the optimizers, Adadelata performs the worst, giving a constant validation accuracy after being trained till a certain number (usually  $< 6$ ) of epochs (termed as Model broken in Table 17). HAN performs worse with RMSprop and Adagrad, and is thus much more sensitive to the optimizer used. SGD with a learning rate of  $10^{-3}$  when used with decay and Nesterov momentum gives results that are in par with that of Adam.

We conduct our experiments on two types of regularization techniques: dropout (Hinton *et al.* (2012b)) and L2 regularization (Hanson and Pratt (1989); Weigend *et al.* (1991)). We study the effects of both individual techniques as well as of combining both the techniques. The dropout rate was varied in the range 0-0.7. It can be inferred from Table 18 that the performance of the both the models keeps improving till the dropout rate of 0.2 (i.e., turning off 20% of the activations) and start declining on increasing the rate further. The combination of dropout rate of 0.2 and l2 rate of  $10^{-1}$  delivers the optimum results for AM while the HAN model performs best in absence of l2 regularization.

Table 18: Comparison of regularization techniques: number of encoder-decoder layers = 1-1 and 1-2 for AM and HAN respectively, hidden layer size 80, batch size 8, and Adam

Dropout	l2	AM			HAN		
		BLEU	SS	ep	BLEU	SS	ep
0	0	83.8	82.64	33	71.30	68.62	11
	$10^{-2}$	81.80	79.64	36	66.88	65.09	16
0.1	0	81.32	80.66	33	73.81	71.67	14
0.2	0	86.65	85.10	36	<b>83.14</b>	<b>80.89</b>	16
	$10^{-1}$	<b>87.32</b>	<b>85.56</b>	59	75.06	73.11	14
	$10^{-2}$	84.83	82.77	49	75.13	73.25	21
	$10^{-3}$	82.80	79.65	38	72.37	71.77	19
0.3	0	83.22	82.68	41	78.63	76.35	18
0.4	0	82.78	81.61	47	76.94	75.18	23
0.5	0	80.97	80.22	53	73.07	72.22	31
0.6	0	80.03	79.55	61	70.30	68.01	37
0.7	0	78.81	77.94	69	65.86	64.21	46

Table 19 shows that the use of pre-trained character embeddings boost the BLEU score of AM by 13 points while that of the HAN model by nearly 16 points. Thus, we observe that the credibility of the transla-

tion of both the models can be significantly improved by employing suitable pre-trained character embeddings (Section 2.1).

Table 19: Effect of pre-trained character embeddings: hyper-parameters are kept same for both the cases, chosen from the best conditions shown above

Pre-trained Embeddings	AM			HAN		
	BLEU	SS	ep	BLEU	SS	ep
With	<b>87.32</b>	<b>85.56</b>	59	<b>83.14</b>	<b>80.89</b>	21
Without	73.51	71.68	16	64.11	61.33	12

## B Experiments on Hindi-Bangla cognate pairs

We extend our experiments to transducing from Hindi to Bangla, by training on a corpus of Hindi-Bengali cognate pairs. The parallel corpus for Hindi-Bangla comprised of 3220 word pairs. We carried out the same 3:1 split upon this corpus to hold out the test set while making a further split of 0.1 upon the train set (2415 word pairs) to obtain a validation set.

Table 20: Comparison of evaluation metrics between seq2seq, AM, HAN, and TN for Hindi-Bangla cognate pairs.

Metrics	seq2seq	AM	HAN	TN
BLEU	41.88	78.49	73.65	<b>83.76</b>
SS	55.12	77.10	70.22	<b>82.59</b>
WA	9.87%	59.27%	47.19%	<b>71.11%</b>

Table 20 depicts the BLEU, string similarity and word accuracy of all four models on the transduction of Hindi words to their respective Bengali cognates. When compared to table 2 (the results on the same metrics for Hindi-Bhojpuri), all models deliver significantly lower scores on the three metrics. The declination in the scores could be boiled down to two major reasons:

1. *Word formation methods*: Unlike Bhojpuri, Bangla with its root from the Prakrit or middle Indo-Aryan language (which in turn descended

from Sanskrit or old Indo-Aryan language - which Hindi also shares a common root with), is neither a dialect nor an immediate descendant of Hindi. This also means that Bangla, which hosts its own Nagari-derived script, namely the Bengali script has its intrinsic word formation rules, some of which are quite contrary to Hindi. One such instance is the Bangla consonant clustering mechanism. For example, the noun Vishnu, written as [viRNu] in Hindi, has the consonant cluster  $\text{ṣa} + \text{ṇa}$  [RN]. While the Hindi consonant cluster ( + ) can easily be decomposed into its constituent letters, the Bangla cluster turns out to form pretty much a new letter in itself.

2. *Smaller size of the training corpora:* The training corpora for Hindi-Bangla cognate pairs comprises of 2415 word pairs, i.e. 1000 instances lesser than that of Hindi-Bhojpuri train set. The aforementioned grammatical restrictions shared by Hindi and Bangla made it very demanding to discover more such cognate pairs in between the two languages, thus resulting in our experiments carried upon a very restricted training corpora.

Table 21 depicts the performance of the AM and HAN model with and without the use of character embeddings derived from pre-trained FastText embeddings (Section 2.1). In addition to the performance improvements being apparent throughout the metrics, the increased number of training epochs before convergence of the models remains in line with the trends in Table 19.

Table 21: Effect of pre-trained character embeddings for Hindi-Bangla cognate pairs

Pre-trained Embeddings	AM			HAN		
	BLEU	SS	ep	BLEU	SS	ep
With	<b>78.49</b>	<b>77.10</b>	56	<b>73.65</b>	<b>70.22</b>	26
Without	72.66	72.25	19	60.07	58.46	10

*This work is licensed under the Creative Commons Attribution 3.0 Unported License.*  
<http://creativecommons.org/licenses/by/3.0/>

