

# AttentionXML: Extreme Multi-Label Text Classification with Multi-Label Attention Based Recurrent Neural Networks

Ronghui You<sup>1</sup>, Suyang Dai<sup>1</sup>, Zihan Zhang<sup>1</sup>, Hiroshi Mamitsuka<sup>2,3</sup>, Shanfeng Zhu<sup>1</sup>

<sup>1</sup> School of Computer Science and Shanghai Key Lab of Intelligent Information Processing  
Fudan University, Shanghai, China.

<sup>2</sup> Bioinformatics Center, Institute for Chemical Research, Kyoto University, Uji, Kyoto Prefecture, 611-0011, Japan.

<sup>3</sup> Department of Computer Science, Aalto University, Helsinki, Finland.

18110240018@fudan.edu.cn, 16210240005@fudan.edu.cn, 17210240027@fudan.edu.cn  
mami@kuicr.kyoto-u.ac.jp, zhusf@fudan.edu.cn

## Abstract

Extreme multi-label text classification (XMTC) is a task for tagging each given text with the most relevant multiple labels from an extremely large-scale label set. This task can be found in many applications, such as product categorization, web page tagging, news annotation and so on. Many methods have been proposed so far for solving XMTC, while most of the existing methods use traditional bag-of-words (BOW) representation, ignoring word context as well as deep semantic information. XML-CNN, a state-of-the-art deep learning-based method, uses convolutional neural network (CNN) with dynamic pooling to process the text, going beyond the BOW-based approaches but failing to capture 1) the long-distance dependency among words and 2) different levels of importance of a word for each label. We propose a new deep learning-based method, AttentionXML, which uses bidirectional long short-term memory (LSTM) and a multi-label attention mechanism for solving the above 1st and 2nd problems, respectively. We empirically compared AttentionXML with other six state-of-the-art methods over five benchmark datasets. AttentionXML outperformed all competing methods under all experimental settings except only a couple of cases. In addition, a consensus ensemble of AttentionXML with the second best method, Parabel, could further improve the performance over all five benchmark datasets.

## Introduction

Extreme multi-label text classification (XMTC) is a natural language process (NLP) task for tagging each given text with its most relevant multiple labels from an extremely large-scale label set. XMTC predicts multiple labels for one text, being different from multi-class classification, where each instance has only one related label. Recently, XMTC has become increasingly important, due to the fast growth of data scale. In fact, over tens of thousands, even hundreds of thousands labels can be found in various domains, such as product categorization in e-commerce, web page tagging, medical subject heading indexing of biomedical documents,

news annotation, to name a few. XMTC poses great computational challenges for developing effective and efficient classifiers, such as the extreme number of instances/labels and a large number of “tail labels” with very few positive instances.

Many methods have been proposed for addressing the challenges of XMTC (Bhatia et al. 2015; Prabhu and Varma 2014; Yen et al. 2016; 2017; Babbar and Schölkopf 2017; Liu et al. 2017; Jain, Prabhu, and Varma 2016; Prabhu et al. 2018b; Tagami 2017; Prabhu et al. 2018a). Traditional methods for XMTC use a bag-of-words (BOW) text representation, ignoring the context of words in text and thus cannot capture deep semantics of text. Most recently, deep learning methods have been proposed to tackle text classification (Kim 2014; Joulin et al. 2017; Jernite, Chormanska, and Sontag 2017), as well as XMTC (Liu et al. 2017). The state-of-the-art and most representative deep learning-based method is XML-CNN (Liu et al. 2017), which uses word embeddings and convolutional neural network (CNN) with a dynamic pooling to process text. However, due to the limited window size, XML-CNN cannot capture the long-distance dependency among text. In addition, all deep learning-based methods including XML-CNN use the same text representation for each label, failing to capture the most relevant part of text to each label.

We propose a new deep learning-based method, AttentionXML, which uses a bidirectional recurrent neural network (RNN) instead of CNN and also a multi-label attention mechanism, to address the above first and second problems, respectively. Experimental results on five benchmark datasets show that AttentionXML outperformed all other six state-of-the-art methods for XMTC. The classification performance was further improved by a consensus integration of AttentionXML and the second best method. We emphasize that this performance improvement is a sizable difference in applications.

We here summarize the three most major contributions of the proposed method, AttentionXML, as follows: 1) In contrast to CNN of XML-CNN, Atten-

tionXML takes the advantage of RNN by which the long-distance dependency among words can be captured; 2) AttentionXML is the first method, which introduces an attention mechanism for XMTC, by which the most relevant part of text to each label can be detected; 3) The performance of AttentionXML was thoroughly examined by using five benchmark datasets, showing the advantage over the other six state-of-the-art XMTC methods.

## Related Work

We can first categorize existing work (except deep learning-based methods) into the following three types: 1) 1-vs-All, 2) Embedding-based, and 3) Tree-based methods, which all will be described briefly.

### 1-vs-All Methods

1-vs-All methods, such as 1-vs-All SVM, train a classifier (e.g. SVM) for each label independently. A clear weak point is that the computational complexity is very high, and the model size can be huge, due to the extreme large number of labels and instances.

Recently, to reduce the complexity, PD-Sparse (Yen et al. 2016) and PPDSparse (Yen et al. 2017) are proposed by the idea of sparse learning. PD-Sparse trains a classifier for each label by a margin-maximizing loss function with the  $L_1$  penalty to obtain an extremely sparse solution both in primal and dual, without sacrificing the expressive power of the predictor. PPDSparse (Yen et al. 2017) is an extension of PD-Sparse, by efficient parallelization of large-scale distributed computing (e.g. 100 cores), keeping a similar performance to PD-Sparse.

DiSMEC (Babbar and Schölkopf 2017) is another state-of-the-art 1-vs-All method, based on distributed computing, which learns a linear classifier for each label. DiSMEC uses a double layer of parallelization to sufficiently exploit computing resource (400 cores), implementing a significant speed-up of training and prediction. DiSMEC prunes spurious weight coefficients (close to zero), which makes the model thousands of times smaller, resulting in reducing the required computational resource to a much smaller size than those by other state-of-the-art methods.

### Embedding-based Methods

The idea of embedding-based methods is, since the label size is huge, to compress the labels and use the compressed labels for training, and finally compressed labels are decompressed for prediction. More specifically, given  $n$  training instances  $(\mathbf{x}_i, \mathbf{y}_i) (i = 1, \dots, n)$ , where  $\mathbf{x}_i \in \mathbb{R}^d$  is a  $d$ -dimensional feature vector and  $\mathbf{y}_i \in \{0, 1\}^L$  is a  $L$ -dimensional label vector. Embedding-based methods compress  $\mathbf{y}_i$  into a lower  $\hat{L}$ -dimensional embedding vector  $\mathbf{z}_i$  by  $\mathbf{z}_i = f_C(\mathbf{y}_i)$ , where  $f_C$  is called a compression function. Then embedding-based methods train regression model  $f_R$  for predicting embedding

vector  $\mathbf{z}_i$  with input feature vector  $\mathbf{x}_i$ . For a given instance with feature vector  $\mathbf{x}_i$ , embedding-based methods predict its embedding vector  $\mathbf{z}_i$  by  $\mathbf{z}_i = f_R(\mathbf{x}_i)$  and predict label vector  $\hat{\mathbf{y}}_i$  by  $\hat{\mathbf{y}}_i = f_D(\mathbf{z}_i)$  where  $f_D$  is called a decompression function. A disadvantage is that feature space  $X$  and label space  $Y$  are projected into a low dimensional space  $Z$  for efficiency, by which some information must be lost through this process, sometimes resulting in limited success only.

The main difference among different embedding-based methods is the design of compression function  $f_C$  and decompression function  $f_D$ . For example, the most representative method, SLEEC (Bhatia et al. 2015), learns embedding vectors  $\mathbf{z}_i$  by capturing non-linear label correlations, preserving the pairwise distance between label vectors,  $\mathbf{y}_i$  and  $\mathbf{y}_j$ , i.e.  $d(\mathbf{z}_i, \mathbf{z}_j) \approx d(\mathbf{y}_i, \mathbf{y}_j)$  if  $i$  is in the  $k$  nearest neighbors of  $j$ . Regressors  $\mathbf{V}$  are then trained to predict embedding label  $\mathbf{z}_i = \mathbf{V}\mathbf{x}_i$ , and a  $k$ -nearest neighbor classifier (KNN) is used for prediction. KNN has high computational complexity, so SLEEC uses clusters, into which training instances are embedded. That is, given a test instance, only the cluster into which this instance can be fallen is used for prediction.

AnnexML (Tagami 2017) is an extension of SLEEC, solving three problems of SLEEC: 1) clustering without labels; 2) ignoring the distance value in prediction (since just KNN is used); and 3) slow prediction. AnnexML generates a KNN graph (KNNG) of label vectors in the embedding space, addressing the above problems, and improves both the accuracy and efficiency.

### Tree-based Methods

Tree-based methods use the idea of (classical) decision tree. They generate a tree by recursive partitioning over given instances by features at non-terminal nodes, resulting in a simple classifier at each leaf with only a few active labels. Also following the idea of random forest, most tree-based methods generate an ensemble of trees, selecting (sampling) a feature subset randomly at each node of the trees. A clear disadvantage of the tree-based method is low performance, because selection at a node of each tree is just an approximation.

The most representative tree-based method, FastXML (Prabhu and Varma 2014), learns a hyperplane to split instances rather than selecting a single feature. More in detail, FastXML optimizes an nDCG-based ranking loss function at each node. An extension of FastXML is PfastreXML (Jain, Prabhu, and Varma 2016), which keeps the same architecture as FastXML, and PfastreXML uses a propensity scored objective function, instead of optimizing nDCG. Due to this objective function, PfastreXML makes more accurate tail label prediction over FastXML.

Another state-of-the-art tree-based method is Parabel (Prabhu et al. 2018b), which learns balanced trees partitioning labels rather than instances. It also incorporates the idea of 1-vs-All, to take advantage of both tree-based and 1-vs-All methods. Parabel

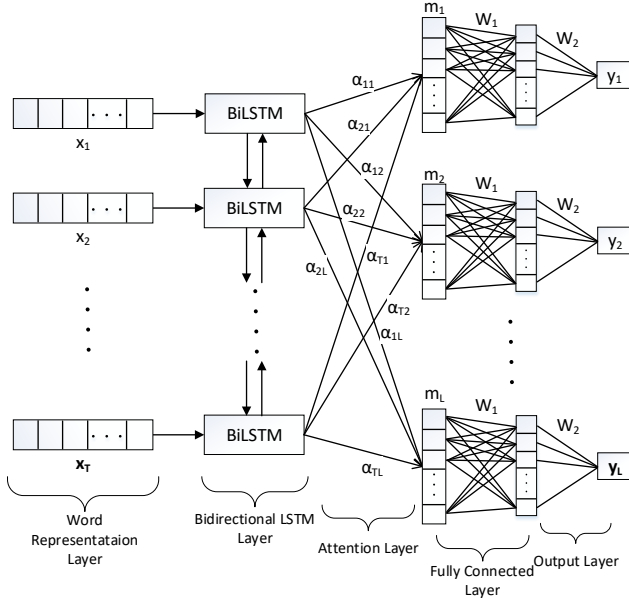

Figure 1: The overview of AttentionXML with text (length  $T$ ) for input and predicted scores  $y$  for output. The  $x_i \in \mathbb{R}^d$  is the embeddings of  $i_{th}$  word,  $\alpha \in \mathbb{R}^{T \times L}$  is the attention coefficients and  $W_1$  and  $W_2$  are parameters of the fully connected layer and output layer, respectively.

achieves almost the same prediction performance as both two state-of-the-art 1-vs-All methods, DiSMEC and PPSparse, keeping high efficiency even by a machine with only one core.

## Method

AttentionXML consists of four layers: 1) Word Representation Layer, 2) Bidirectional LSTM Layer, 3) Multi-label Attention Layer, and 4) Fully Connected and Output Layer. Fig. 1 shows a schematic picture of AttentionXML.

### 1. Word Representation Layer

The input of AttentionXML is raw tokenized text. Each word is represented by a deep semantic dense vector, called *word embedding* (Mikolov et al. 2013). Let  $T$  and  $d$  be the length of the input text and the dimension of word representation, respectively. The output of word representation layer  $\mathbf{X} \in \mathbb{R}^{T \times d}$  is

$$\mathbf{X} = (\mathbf{x}_1, \mathbf{x}_2, \dots, \mathbf{x}_T), \quad (1)$$

where  $x_t \in \mathbb{R}^d$  is a dense vector for each word. In our experiment, we used pre-trained 300-dimensional GloVe (Pennington, Socher, and Manning 2014) word embedding as our initial word representation.

### 2. Bidirectional LSTM Layer

Recurrent neural network (RNN) is a type of neural network with a memory state to process sequence in-

puts. Traditional RNN has a problem called *gradient vanishing and exploding* during training (Bengio, Simard, and Frasconi 1994). Long short-term memory (LSTM) (Hochreiter and Schmidhuber 1997) is proposed for solving this problem. Let  $\mathbf{x}_t, \mathbf{h}_t \in \mathbb{R}^m$  and  $\mathbf{c}_t \in \mathbb{R}^m$  be the input, the so-called *memory state vector* and the so-called *memory cellvector* at time  $t$ . LSTM can obtain  $\mathbf{h}_t$  and  $\mathbf{c}_t$  as follows:

$$\begin{aligned} \mathbf{i}_t &= \sigma(\mathbf{W}_i \mathbf{x}_t + \mathbf{U}_i \mathbf{h}_{t-1} + \mathbf{b}_i), \\ \mathbf{f}_t &= \sigma(\mathbf{W}_f \mathbf{x}_t + \mathbf{U}_f \mathbf{h}_{t-1} + \mathbf{b}_f), \\ \mathbf{o}_t &= \sigma(\mathbf{W}_o \mathbf{x}_t + \mathbf{U}_o \mathbf{h}_{t-1} + \mathbf{b}_o), \\ \mathbf{g}_t &= \tanh(\mathbf{W}_g \mathbf{x}_t + \mathbf{U}_g \mathbf{h}_{t-1} + \mathbf{b}_g), \\ \mathbf{c}_t &= \mathbf{f}_t \odot \mathbf{c}_{t-1} + \mathbf{i}_t \odot \mathbf{g}_t, \\ \mathbf{h}_t &= \mathbf{o}_t \odot \tanh(\mathbf{c}_t), \end{aligned} \quad (2)$$

where  $\odot$  is element-wise multiplication,  $\mathbf{W}_{i,f,o,g} \in \mathbb{R}^{n \times d}$  and  $\mathbf{U}_{i,f,o,g} \in \mathbb{R}^{n \times n}$  are matrices to be trained,  $\mathbf{b}_{i,f,o,g} \in \mathbb{R}^n$  are bias terms, and  $\mathbf{i}_t, \mathbf{f}_t$  and  $\mathbf{o}_t$  are called an *input gate*, a *forget gate* and an *output gate*, respectively.

We use a Bidirectional LSTM (BiLSTM) to capture both the left- and right-sides context at each time step (Fig. 1), where  $\mathbf{h}_t$  is obtained by concatenating forward  $\overrightarrow{\mathbf{h}}_t$  and backward  $\overleftarrow{\mathbf{h}}_t$ . The entire output of BiLSTM  $H \in \mathbb{R}^{T \times 2n}$  can be obtained as follows:

$$\mathbf{H} = (\mathbf{h}_1, \mathbf{h}_2, \dots, \mathbf{h}_T). \quad (3)$$

### 3. Multi-Label Attention Layer

Recently so-called *attention mechanism* in neural networks has been successful used in many NLP tasks, such as machine translation, machine comprehension, relation extraction, speech recognition (Bahdanau, Cho, and Bengio 2014). The most relative context to each label can be different in XMTCL. AttentionXML computes the (linear) combination of context vectors  $\mathbf{h}_i$  for each label through *self-attention mechanism*, inspired by (Lin et al. 2017), to capture various intensive parts of a paragraph. That is, the output of multi-label attention layer  $\mathbf{m}_j \in \mathbb{R}^{2n}$  of the  $j$ -th label can be obtained as follows:

$$\begin{aligned} \alpha_{ij} &= \frac{e^{\mathbf{h}_i \mathbf{w}_j^T}}{\sum_{t=1}^T e^{\mathbf{h}_t \mathbf{w}_j^T}}, \\ \mathbf{m}_j &= \sum_{i=1}^T \alpha_{ij} \mathbf{h}_i, \end{aligned} \quad (4)$$

where  $\alpha_{ij}$  is the normalized coefficient of  $\mathbf{h}_i$  and  $\mathbf{w}_j \in \mathbb{R}^{2n}$  is the so-called attention parameters.

### 4. Fully Connected and Output Layer

AttentionXML has one (or two) fully connected layers and one output layer. To keep the model size small, we use the same parameter values of the fully connected layers for all labels. The final, predicted probability  $\hat{y}_j$  for the  $j$ -th label can be obtained as follows:

$$\hat{y}_j = \sigma(\mathbf{W}_2 f(\mathbf{W}_1 \mathbf{m}_j)), \quad (5)$$

Table 1: Datasets we used in our experiments.

Dataset	$N_{train}$	$N_{test}$	$D$	$L$	$\bar{L}$	$\hat{L}$	$\bar{W}_{train}$	$\bar{W}_{test}$
RCV1	23,149	781,265	47,236	103	3.18	729.67	267.51	276.52
EUR-Lex	15,449	3,865	186,104	3,956	5.30	7.79	1248.58	1230.40
Wiki10-31K	14,146	6,616	101,938	30,938	8.52	18.64	2484.30	2425.45
WikiLSHTC	456,886	81,262	346,299	36,504	1.86	4.33	122.74	122.87
AmazonCat-13K	1,186,239	306,782	203,882	13,330	5.04	448.57	246.61	245.98

$N_{train}$ : #training instances,  $N_{test}$ : #test instances,  $D$ : #features,  $L$ : #labels,  $\bar{L}$ : average #labels per instance,  $\hat{L}$ : the average #instances per label,  $\bar{W}_{train}$ : the average #words per training instance and  $\bar{W}_{test}$ : the average #words per test instance. The partition of training and test is from the data source.

where  $\mathbf{W}_1 \in \mathbb{R}^{b \times 2n}$  is parameters of the fully connected layer,  $\mathbf{W}_2 \in \mathbb{R}^b$  is parameters of the output layer and function  $f$  is a non-linear (activation) function.

## Loss Function

AttentionXML uses the cross-entropy loss function, which was used in XML-CNN (Liu et al. 2017) as the loss function. Since the number of labels for each instance varies, we did not normalize the predicted probability. The loss function is given as follow:

$$J(\theta) = -\frac{1}{NL} \sum_{i=1}^N \sum_{j=1}^L y_{ij} \log(\hat{y}_{ij}) + (1 - y_{ij}) \log(1 - \hat{y}_{ij}), \quad (6)$$

where  $N$  is the number of samples,  $L$  is the number of labels,  $\hat{y}_{ij} \in [0, 1]$  and  $y_{ij} \in \{0, 1\}$  are the predicted probability and true values, respectively, for the  $i$ -th sample and the  $j$ -th label.

## Experiments

### Datasets

We used five multi-label text classification benchmark datasets (Table 1): RCV1<sup>1</sup> (Lewis et al. 2004), EUR-Lex<sup>2</sup> (Mencia and Furnkranz 2008), Wiki10-31K<sup>3</sup> (Zubiaga 2012), WikiLSHTC<sup>4</sup> (Partalas et al. 2015) and AmazonCat-13K<sup>3</sup> (McAuley and Leskovec 2013). The last two (which we call *large-scale*) are much larger than the first three datasets (which we call *medium-scale*) in terms of instance or label size. All five datasets are publicly available except RCV1, which can be obtained from NIST (National Institute of Standards and Technology) by request.

### Competing Methods

We compared the performance of AttentionXML with six state-of-the-art and most representative XMTC methods (implemented by the original authors): XML-CNN<sup>3</sup> (deep learning), PD-Sparse<sup>5</sup> (1-vs-All),

<sup>1</sup><https://ir.nist.gov/reuters/us>

<sup>2</sup><http://www.ke.tu-darmstadt.de/resources/eurlex/eurlex.html>

<sup>3</sup><http://manikvarma.org/downloads/XC/XMLRepository.html>

<sup>4</sup><http://lshtc.iit.demokritos.gr>

<sup>5</sup><http://www.cs.utexas.edu/~xrhuang/PDSparse/>

SLEEC<sup>3</sup> (embedding) and AnnexML<sup>6</sup> (embedding), PfastreXML<sup>3</sup> (tree) and Parabel<sup>3</sup> (tree). In addition, to check the effect of attention mechanism, we also compared the performance of AttentionXML without attention mechanism (denoted as XML-RNN hereafter). DiSMEC and PPDSParse were excluded due to their extensive computing resource requirements.

## Experimental Settings

For the three medium-scale datasets, we used 256 hidden units in LSTM and one fully-connected layer (with 256 hidden units) in AttentionXML, while for the two large-scale datasets, 512 hidden units in LSTM and two fully-connected layers (with 512 and 256 hidden units, respectively) were used instead. The dropout rate was 0.5, and we used ReLU as the activation function in the fully-connected layer. Our model was trained by Adam with the learning rate of 0.001 and the batch size was 40. We ran 50 and 10 epochs for medium-scale and large-scale datasets, respectively. We used an early stopping strategy to avoid overfitting and accelerate training. Note that because of early stopping, the epochs we ran in fact can be fewer than the above settings. We used the settings as suggested by their authors for all competing methods, except XML-RNN, in which we used the same settings as AttentionXML (with a max pooling instead of attention mechanism).

## Evaluation Metrics

We chose  $P@k$  (Precision at  $k$ ) and  $nDCG@k$  (normalized Discounted Cumulative Gain at  $k$ ) as our evaluation metrics for performance comparison, since both  $P@k$  and  $nDCG@k$  are widely used for evaluation methods for multi-label classification problems.  $P@k$  is defined as follows:

$$P@k = \frac{1}{k} \sum_{l=1}^k \mathbf{y}_{rank(l)} \quad (7)$$

where  $\mathbf{y} \in \{0, 1\}^L$  is the true binary vector, and  $rank(l)$  is the index of the  $l$ -th highest predicted label.

<sup>6</sup>[https://s.yimg.jp/dl/docs/research\\_lab/annexml-0.0.1.zip](https://s.yimg.jp/dl/docs/research_lab/annexml-0.0.1.zip)

Table 2: Performance comparison of AttentionXML and other seven competing methods in terms of P@k

Dataset	Metrics	Methods							
		SLEEC	AnnexML	PfastreXML	PD-Sparse	Parabel	XML-CNN	XML-RNN	AttentionXML
RCV1	P@1	94.69(6)	95.26(4)	94.11(7)	93.72(8)	<b>95.85(1)</b>	94.79(5)	95.30(3)	95.76(2)
	P@3	78.90(7)	79.30(5)	79.59(4)	78.74(8)	80.05(3)	78.93(6)	80.42(2)	<b>81.22(1)</b>
	P@5	54.24(8)	55.25(5)	55.80(4)	54.82(6)	55.88(3)	54.59(7)	55.99(2)	<b>56.75(1)</b>
EUR-Lex	P@1	79.09(4)	79.56(3)	73.14(8)	74.00(7)	82.12(2)	75.32(5)	74.77(6)	<b>82.87(1)</b>
	P@3	64.14(4)	64.92(3)	60.16(7)	60.24(6)	68.91(2)	60.14(8)	61.04(5)	<b>70.35(1)</b>
	P@5	52.51(4)	53.53(3)	50.54(5)	49.64(7)	57.89(2)	49.21(8)	50.11(6)	<b>58.39(1)</b>
Wiki10-31K	P@1	85.88(2)	<b>86.50(1)</b>	83.57(4)	75.63(8)	84.19(3)	81.41(7)	82.94(6)	83.03(5)
	P@3	72.98(3)	74.29(2)	68.61(6)	62.95(8)	72.46(4)	66.23(7)	69.77(5)	<b>74.58(1)</b>
	P@5	62.70(4)	64.20(2)	59.10(6)	52.90(8)	63.37(3)	56.11(7)	59.38(5)	<b>65.28(1)</b>
WikiLSHTC	P@1	48.57(8)	57.78(3)	50.85(7)	53.26(6)	58.79(2)	55.17(5)	57.02(4)	<b>62.89(1)</b>
	P@3	27.25(8)	33.09(3)	29.62(7)	30.72(6)	34.47(2)	31.09(5)	31.82(4)	<b>36.05(1)</b>
	P@5	18.46(8)	22.54(3)	20.17(7)	20.91(6)	23.33(2)	21.13(5)	21.46(4)	<b>24.32(1)</b>
AmazonCat-13K	P@1	90.53(7)	93.54(3)	91.75(6)	88.85(8)	93.02(5)	93.26(4)	94.08(2)	<b>94.83(1)</b>
	P@3	76.33(7)	78.38(4)	77.97(5)	73.20(8)	79.14(2)	77.06(6)	78.41(3)	<b>80.45(1)</b>
	P@5	61.52(6)	63.32(4)	63.68(3)	59.24(8)	64.51(2)	61.40(7)	62.34(5)	<b>65.24(1)</b>
Average Rank		5.73	3.20	5.73	7.20	2.53	6.13	4.13	<b>1.33</b>
p-value		8.55e-4	4.27e-3	1.22e-4	6.10e-5	1.53e-3	6.10e-5	6.10e-5	

Table 3: Performance comparison of AttentionXML and other seven competing methods in terms of nDCG@k

Dataset	Metrics	Methods							
		SLEEC	AnnexML	PfastreXML	PD-Sparse	Parabel	XML-CNN	XML-RNN	AttentionXML
RCV1	nDCG@1	94.69(6)	95.26(4)	94.11(7)	93.72(8)	<b>95.85(1)</b>	94.79(5)	95.30(3)	95.76(2)
	nDCG@3	90.05(7)	90.26(4)	90.16(5)	89.73(8)	91.01(3)	90.13(6)	91.60(2)	<b>92.33(1)</b>
	nDCG@5	90.32(8)	91.12(5)	91.31(4)	90.65(7)	91.86(3)	90.73(6)	92.44(2)	<b>93.29(1)</b>
EUR-Lex	nDCG@1	79.09(4)	79.56(3)	73.14(8)	74.00(7)	82.12(2)	75.32(5)	74.77(6)	<b>82.87(1)</b>
	nDCG@3	67.96(4)	68.65(3)	63.51(8)	63.77(7)	72.33(2)	63.95(6)	64.55(5)	<b>73.65(1)</b>
	nDCG@5	61.76(4)	62.68(3)	58.71(6)	58.38(7)	66.95(2)	58.11(8)	58.78(5)	<b>67.67(1)</b>
Wiki10-31K	nDCG@1	85.88(2)	<b>86.50(1)</b>	83.57(4)	75.63(8)	84.19(3)	81.41(7)	82.94(6)	83.03(5)
	nDCG@3	76.02(3)	<b>77.16(1)</b>	72.00(6)	65.92(8)	75.22(4)	69.78(7)	72.92(5)	76.62(2)
	nDCG@5	68.13(4)	69.44(2)	64.54(6)	58.19(8)	68.22(3)	61.83(7)	64.91(5)	<b>69.68(1)</b>
WikiLSHTC	nDCG@1	48.57(8)	57.78(3)	50.85(7)	53.26(6)	58.79(2)	55.17(5)	57.02(4)	<b>62.89(1)</b>
	nDCG@3	47.52(8)	57.64(3)	50.77(7)	53.85(6)	59.26(2)	54.28(5)	55.78(4)	<b>62.48(1)</b>
	nDCG@5	49.06(8)	59.65(3)	52.57(7)	55.92(6)	61.12(2)	56.21(5)	57.51(4)	<b>64.38(1)</b>
AmazonCat-13K	nDCG@1	90.53(7)	93.54(3)	91.75(6)	88.85(8)	93.02(5)	93.26(4)	94.08(2)	<b>94.83(1)</b>
	nDCG@3	84.96(7)	87.30(4)	86.48(5)	81.82(8)	87.70(2)	86.20(6)	87.55(3)	<b>89.33(1)</b>
	nDCG@5	82.77(7)	85.12(3)	84.96(4)	79.92(8)	85.98(2)	83.43(6)	84.61(5)	<b>87.31(1)</b>
Average Rank		5.80	3.00	6.00	7.33	2.53	5.87	4.07	<b>1.40</b>
p-value		6.10e-4	5.37e-3	1.22e-4	6.10e-5	6.10e-4	6.10e-5	6.10e-5	

Table 4: The overlap of AttentionXML and Parabel

Dataset	Top1	Top2	Top3	Top4	Top5
RCV1	59%	73%	79%	73%	69%
EUR-Lex	43%	53%	59%	62%	63%
Wiki10-31K	48%	56%	58%	59%	59%
WikiLSHTC	48%	48%	43%	40%	37%
AmazonCat-13K	65%	69%	72%	73%	72%

$nDCG@k$  is defined as follows:

$$\begin{aligned}
 DCG@k &= \sum_{l=1}^k \frac{y_{rank(l)}}{\log(l+1)} \\
 iDCG@k &= \sum_{l=1}^{\min(k, ||y||_0)} \frac{1}{\log(l+1)} \\
 nDCG@k &= \frac{DCG@k}{iDCG@k}
 \end{aligned} \tag{8}$$

$nDCG@k$  is a metric for ranking, meaning that the order of top  $k$  prediction was considered in  $nDCG@k$  but not in  $P@k$ . Note that  $P@1$  and  $nDCG@1$  are the same.

## Performance Comparison

Tables 2 and 3 show the performance of all competing methods by  $P@k$  and  $nDCG@k$ , respectively, on all five

datasets<sup>7</sup>. Following previous work on XMTC, we focus on top predictions by changing  $k$  at 1, 3 and 5 in the evaluation metrics. So each method has fifteen results by the combination of three values of  $k$  and five datasets (for one metric). We then compute the average rank for each method over all fifteen results. Below are the points of summary we had from the two tables.

1) AttentionXML performed the best, being followed by Parabel and AnnexXML. For example, AttentionXML achieved the average rank of 1.33 for  $P@k$ , being the best in 13 out of 15 results, while Parabel and AnnexXML were 2.53 and 3.20, respectively. We further used Wilcoxon Signed Rank Test to examine the statistical significance of performance advantages, where  $p$ -values (the last row of Tables 2 and 3) indicate the statistical significance for all cases at the level of 0.05.

2) PD-Sparse presented the worst performance with the average ranks of 7.20 and 7.33 in  $P@k$  and  $nDCG@k$ , respectively, which might be because of losing some important information by the sparse solution of PD-Sparse for computational efficiency.

3) Parabel took advantage of both tree-based (Pfas-

<sup>7</sup>SLEEC and PfastreXML on Wiki10-31K and AmazonCat-13K are from **Extreme Classification Repository** (<http://manikvarma.org/downloads/XC/XMLRepository.html>) directly.

GMail Drive is a free third-party Windows Shell namespace extension ("add-on") for Google's Gmail. GMail Drive is not supported by Google. It allows a user to access a virtual drive stored in a Gmail e-mail account by causing the contents of the Gmail account to appear as a new network share on the user's workstation. In order to use this add-on, the user needs a Gmail e-mail account. The add-on enables the user to use the standard Windows desktop file copy and paste commands to transfer files to and from the Gmail account as if it were a drive on the user's computer. In order for GMail Drive to operate, the computer must be connected to the Internet and the user must have a Gmail account. A broadband connection is preferable, though not necessary, as all operations are done through Gmail and consequently over the Internet. GMail Drive uses the inbox of the Gmail account to store files and creates a virtual filesystem on top of the Gmail account, enabling the user to save and retrieve files stored on the Gmail account directly from inside Windows Explorer. GMail Drive adds a new virtual drive to the computer under the My Computer folder, where the user can create new folders, copy and drag-and-drop files to, but does not give an actual drive letter, such as C:, preventing its use in all DOS applications, and some older Windows applications. When the user creates a new file using GMail Drive, it generates an e-mail and posts it to the Gmail account's inbox. The e-mail appears in the normal Inbox folder when using the normal Gmail interface, and the file is attached as an e-mail attachment. GMail Drive periodically checks the mail account (using the Gmail search function) to see if new files have arrived and to rebuild the virtual drive's directory structures. Multiple computers can connect to one Gmail account thus allowing GMail Drive to act as a multi-user file server. Consequently, restrictions on the Gmail service are also enforced when using GMail Drive. For example, files larger than 20 MB can not be uploaded, as the maximum file size of Gmail attachments is 20 MB [1]. In the past, Gmail also prevented users from transferring certain file types, such as an executable or ZIP archive. (Remark: It seems possible now to transfer those file types to a Gmail Drive.) Some users bypassed this restriction by renaming the file extension or by putting it into a RAR or 7zip archive. A GNU software package named PHPGmailDrive even makes it possible to link different Gmail accounts together, and with some manual changes you can have a Gmail Drive built out of several Gmail accounts. GMail Drive is an experimental package that depends on but is not provided by Google. Changes in Google's Gmail system may render GMail Drive temporarily or permanently inoperable. The current GMail Drive does not support accounts that are with Google Apps The Gmail Program Policies do not explicitly ban GMail Drive, shell namespace extensions, or the use of Gmail storage space for files other than e-mail. [2] Nonetheless, immoderate use of GMail Drive may trigger Google to temporarily suspend a Gmail account. [3]

Figure 2: Attention of a test instance (wiki entry: GMail Driver) to the label "gmail" in Wiki10-31K.

Table 5: The performance of a consensus ensemble AttentionXML and Parabel in terms of P@k and nDCG@k

Dataset	Methods				Methods			
	Metrics	Parabel	AttentionXML	Consensus	Metrics	Parabel	AttentionXML	Consensus
RCV1	P@1	<b>95.85</b>	95.76	95.68	nDCG@1	<b>95.85</b>	95.76	95.68
	P@3	80.05	81.22	<b>81.72</b>	nDCG@3	91.01	92.33	<b>92.70</b>
	P@5	55.88	56.75	<b>57.06</b>	nDCG@5	91.86	93.29	<b>93.58</b>
EUR-Lex	P@1	82.12	82.87	<b>85.46</b>	nDCG@1	82.12	82.87	<b>85.46</b>
	P@3	68.91	70.35	<b>72.64</b>	nDCG@3	72.33	73.65	<b>76.03</b>
	P@5	57.89	58.39	<b>60.48</b>	nDCG@5	66.95	67.67	<b>70.03</b>
Wiki10-31K	P@1	84.19	83.03	<b>85.69</b>	nDCG@1	84.19	83.03	<b>85.69</b>
	P@3	72.46	74.58	<b>77.14</b>	nDCG@3	75.22	76.62	<b>79.26</b>
	P@5	63.37	65.28	<b>67.72</b>	nDCG@5	68.22	69.68	<b>72.23</b>
WikiLSHTC	P@1	58.79	62.89	<b>64.74</b>	nDCG@1	58.79	62.89	<b>64.74</b>
	P@3	34.47	36.05	<b>37.46</b>	nDCG@3	59.26	62.48	<b>64.77</b>
	P@5	23.33	24.32	<b>25.35</b>	nDCG@5	61.12	64.38	<b>66.82</b>
AmazonCat-13K	P@1	93.02	94.83	<b>95.12</b>	nDCG@1	93.02	94.83	<b>95.12</b>
	P@3	79.14	80.45	<b>81.62</b>	nDCG@3	87.70	89.33	<b>90.31</b>
	P@5	64.51	65.24	<b>66.57</b>	nDCG@5	85.98	87.31	<b>88.58</b>

treXML) and 1-vs-ALL methods (PD-Sparse), outperforming the original two methods. For example, by  $P@k$ , Parabel achieved the average rank of 2.53, while PfastreXML and PD-Sparse achieved 5.73 and 7.20, respectively.

4) AnnealXML (the latest embedding) outperformed SLEEC in all settings, highlighting the effectiveness of AnnealXML, which addresses the shortcoming of SLEEC.

5) Embedding-based methods had better performance in Wiki10-31K than other datasets. Specifically, AnnexXML achieved the best scores in  $P@1$  ( $nDCG@1$ ) and  $nDCG@3$ , being followed by SLEEC in  $P@1$  in Wiki10-31K. The average text length of Wiki10-31K is much longer than other datasets (Table 1), and it indicates that the embedding-based methods work for longer text with more information.

6) Regarding deep learning based methods, XML-RNN outperformed XML-CNN on all settings except  $P@1$  ( $nDCG@1$ ) over EUR-Lex. We also ran Wilcoxon Signed Rank Test to confirm the statistical significance of performance advantage ( $p$ -values of  $1.33e-3$  and  $1.87e-4$  in  $P@k$  and  $nDCG@k$ , respectively). This result demonstrated that, the bidirectional RNN in XML-

RNN captured the long-distance dependency among text and it's more useful than CNN with a limited window size for XMTC. Additionally, AttentionXML outperformed XML-CNN and XML-RNN significantly on all five datasets. The improvement was especially notable on EUR-Lex, Wiki10-31K and WikiLSHTC, which have small average number of instances per label (Table 1). In this case, many labels have very few positive instances, where using a single representation for all labels by a simple max pooling of XML-CNN and XML-RNN would be insufficient. In contrast, multi-label attention mechanism in AttentionXML focuses on different parts of text for each label and gains different text representations to each label, which results in the best performance. For example, AttentionXML achieved a value of 62.89% for  $P@1$  on WikiLSHTC, which is more than 12% higher than the ones (around 57%) achieved by XML-CNN and XML-RNN.

## Analysis over Results

**Effect of Attention** We show a typical case, to demonstrate the advantage of attention mechanism in AttentionXML. Fig. 2 shows a typical text example from test data of Wiki10-31K. One of its true labels is

Table 6: Label-based Performance of AttentionXML, Parabel and AnnexML over 3 groups with different frequencies

Dataset	Occurrence	Number	Percentage	AUC			AUPR		
				AnnexML	Parabel	AttentionXML	AnnexML	Parabel	AttentionXML
RCV1	$t \geq 150000$	3	31.35	95.41	96.72	<b>97.41</b>	93.71	96.02	<b>97.34</b>
	$40000 \leq t < 150000$	13	34.62	92.69	92.95	<b>94.20</b>	85.73	88.91	<b>91.52</b>
	$5 \leq t < 40000$	87	34.03	72.61	76.58	<b>77.27</b>	56.42	61.17	<b>64.40</b>
EUR-Lex	$t \geq 47$	71	28.70	82.01	84.24	<b>84.28</b>	61.05	64.23	<b>67.18</b>
	$17 \leq t < 47$	219	28.85	80.44	<b>82.19</b>	81.23	60.01	64.42	<b>64.61</b>
	$5 \leq t < 17$	657	27.18	67.80	73.83	<b>74.51</b>	47.24	<b>55.50</b>	55.14
Wiki10-31K	$t \geq 204$	61	25.46	68.67	74.27	<b>75.49</b>	45.66	44.25	<b>45.74</b>
	$28 \leq t < 204$	507	25.88	58.24	<b>66.52</b>	66.14	33.40	33.05	<b>33.80</b>
	$5 \leq t < 28$	3168	24.85	23.65	<b>48.21</b>	45.11	14.45	<b>23.06</b>	20.90
WikiLSHTC	$t \geq 33$	515	23.14	83.05	84.24	<b>85.13</b>	57.99	60.26	<b>65.10</b>
	$11 \leq t < 33$	2304	24.34	76.59	77.82	<b>77.95</b>	52.26	55.15	<b>60.19</b>
	$5 \leq t < 11$	5136	21.98	70.12	<b>72.48</b>	72.10	48.87	52.19	<b>56.85</b>
AmazonCat-13K	$t \geq 8126$	27	32.70	91.74	92.31	<b>93.09</b>	79.85	83.40	<b>85.69</b>
	$959 \leq t < 8126$	208	33.08	80.75	84.41	<b>85.01</b>	66.54	70.42	<b>71.53</b>
	$5 \leq t < 959$	8165	33.56	70.19	<b>77.76</b>	73.60	60.18	<b>65.90</b>	61.31

“gmail”, which was ranked at the top by AttentionXML (while at the over 100th by XML-RNN). In Fig. 2, each token is highlighted by its attention score to this label computed by AttentionXML. We can see that AttentionXML gives high scores to “Gmail”, “e-mail” and “attachments”, which are all relevant to the true label “gmail”. This result shows that attention mechanism of AttentionXML is effective for XMTC.

**Ensemble of AttentionXML and Parabel** In Tables 2 and 3, AttentionXML and Parabel are the best and second best methods, respectively. AttentionXML, a deep learning method, uses a deep semantic text representation, while Parabel, a tree-based method, uses a sparse BOW text representation. We examined the overlap between the results by these two methods. Table shows the overlap between the top predictions by these two methods, where for example, “Top3” means the overlap between the top three predicted labels. The performances by these two methods are close, while prediction results by these two methods are very different. For example,  $P@5$  on WikiLSHTC by AttentionXML and Parabel were 24.32 and 23.33, respectively, resulting in only 0.99 in difference. However, the overlap of their top five predictions was only 37%.

We then generate an ensemble method (Consensus) of these two methods to improve the performance of an individual method. More specifically we compute probability score  $P(X_i, L_j)$ , which assigns label  $Y_j$  to instance  $X_i$  as follows:

$$P(X_i, L_j) = 1 - (1 - P_0(X_i, L_j)) \times (1 - P_1(X_i, L_j)), \quad (9)$$

where  $P_0(X_i, L_j)$  and  $P_1(X_i, L_j)$  are probability scores given by AttentionXML and Parabel, respectively. Table 5 shows performances by AttentionXML, Parabel and Consensus. We can see that Consensus achieved the best performance in all 30 cases except  $P@1$  ( $nDCG@1$ ) over RCV1. This result demonstrates that AttentionXML and Parabel are complementary to each other, and Consensus by these two methods can improve the performance by an individual.

**Performance Comparison on Different Labels with Different Frequencies** Focusing on three best methods, AttentionXML, Parabel and AnnexML, we examined label-based metrics instead of instance-based

Table 7: Computation time (minutes) for training and test of AttentionXML on two large-scale datasets

Dataset	train	test
WikiLSHTC	1297.75	15.65
AmazonCat-13K	2938.54	41.75

metrics. We divided labels, which appear at least five times in the test dataset, into three groups by their frequencies, keeping the total occurrence of each group as equal as possible. Table 6 shows the average AUC and AUPR over all labels for each group. We can easily see that AttentionXML was best in both AUC and AUPR for the most frequent (and also medium frequent) groups, while Parabel was best for the least frequent group. This result indicates that AttentionXML is useful for frequent labels, and we think that this point would be realized by that Attention XML uses deep learning which performs very well when sufficient data are given.

## Running Time

AttentionXML runs on four Nvidia GTX TITAN X GPUs. Table 7 shows computation time required for training and test of AttentionXML on two large-scale datasets.

## Discussion and Conclusion

We have proposed AttentionXML (for XMTC), a new deep learning method, which has two distinguished features: a bidirectional LSTM and a multi-label attention mechanism for capturing text parts which are relevant most to each label. We examined the predictive performance, comparing with six state-of-the-art methods over five benchmark datasets. Experimental results show that AttentionXML outperformed all other competing methods, being statistically significant. We emphasize that AttentionXML showed better performances than other two deep learning methods, XML-CNN and XML-RNN on all datasets, especially significant on the datasets with small average number of instances per labels, thanks to the attention mechanism of AttentionXML. In addition we generate, Consensus, an



ensemble of AttentionXML and Parabel to further enhance the predictive performance. Finally, a closer examination of AttentionXML on label-based metric indicates that the advantage of AttentionXML over Parabel is derived from its advantage over frequent labels. As deep learning is computationally intensive, an important future work would be to develop a more efficient training algorithm for AttentionXML, to handle very large scale datasets more efficiently.

## Acknowledgment

This work was perviously submitted to AAAI 2019. We would like to thank anonymous reviewers providing helpful suggestions for further modifications.

## References

- Babbar, R., and Schölkopf, B. 2017. DiSMEC: distributed sparse machines for extreme multi-label classification. In *Proceedings of the Tenth ACM International Conference on Web Search and Data Mining*, 721–729. ACM.
- Bahdanau, D.; Cho, K.; and Bengio, Y. 2014. Neural machine translation by jointly learning to align and translate. *arXiv preprint arXiv:1409.0473*.
- Bengio, Y.; Simard, P.; and Frasconi, P. 1994. Learning long-term dependencies with gradient descent is difficult. *IEEE transactions on neural networks* 5(2):157–166.
- Bhatia, K.; Jain, H.; Kar, P.; Varma, M.; and Jain, P. 2015. Sparse local embeddings for extreme multi-label classification. In *Advances in Neural Information Processing Systems*, 730–738.
- Hochreiter, S., and Schmidhuber, J. 1997. Long short-term memory. *Neural computation* 9(8):1735–1780.
- Jain, H.; Prabhu, Y.; and Varma, M. 2016. Extreme multi-label loss functions for recommendation, tagging, ranking & other missing label applications. In *Proceedings of the 22nd ACM SIGKDD International Conference on Knowledge Discovery and Data Mining*, 935–944. ACM.
- Jernite, Y.; Choromanska, A.; and Sontag, D. 2017. Simultaneous learning of trees and representations for extreme classification and density estimation. In *International Conference on Machine Learning*, 1665–1674.
- Joulin, A.; Grave, E.; Bojanowski, P.; and Mikolov, T. 2017. Bag of tricks for efficient text classification. In *Proceedings of the 15th Conference of the European Chapter of the Association for Computational Linguistics: Volume 2, Short Papers*, volume 2, 427–431.
- Kim, Y. 2014. Convolutional neural networks for sentence classification. In *Proceedings of the 2014 Conference on Empirical Methods in Natural Language Processing (EMNLP)*, 1746–1751.
- Lewis, D. D.; Yang, Y.; Rose, T. G.; and Li, F. 2004. Rcv1: A new benchmark collection for text categorization research. *Journal of machine learning research* 5(Apr):361–397.
- Lin, Z.; Feng, M.; Santos, C. N. d.; Yu, M.; Xiang, B.; Zhou, B.; and Bengio, Y. 2017. A structured self-attentive sentence embedding. *arXiv preprint arXiv:1703.03130*.
- Liu, J.; Chang, W.-C.; Wu, Y.; and Yang, Y. 2017. Deep learning for extreme multi-label text classification. In *Proceedings of the 40th International ACM SIGIR Conference on Research and Development in Information Retrieval*, 115–124. ACM.
- McAuley, J., and Leskovec, J. 2013. Hidden factors and hidden topics: understanding rating dimensions with review text. In *Proceedings of the 7th ACM conference on Recommender systems*, 165–172. ACM.
- Mencia, E. L., and Fürnkranz, J. 2008. Efficient pairwise multilabel classification for large-scale problems in the legal domain. In *Joint European Conference on Machine Learning and Knowledge Discovery in Databases*, 50–65. Springer.
- Mikolov, T.; Sutskever, I.; Chen, K.; Corrado, G. S.; and Dean, J. 2013. Distributed representations of words and phrases and their compositionality. In *Advances in neural information processing systems*, 3111–3119.
- Partalas, I.; Kosmopoulos, A.; Baskiotis, N.; Artieres, T.; Paliouras, G.; Gaussier, E.; Androutsopoulos, I.; Amini, M.-R.; and Galinari, P. 2015. LSHTC: a benchmark for large-scale text classification. *arXiv preprint arXiv:1503.08581*.
- Pennington, J.; Socher, R.; and Manning, C. 2014. Glove: Global vectors for word representation. In *Proceedings of the 2014 conference on empirical methods in natural language processing (EMNLP)*, 1532–1543.
- Prabhu, Y., and Varma, M. 2014. FastXML: A fast, accurate and stable tree-classifier for extreme multi-label learning. In *Proceedings of the 20th ACM SIGKDD international conference on Knowledge discovery and data mining*, 263–272. ACM.
- Prabhu, Y.; Kag, A.; Gopinath, S.; Dahiya, K.; Harsola, S.; Agrawal, R.; and Varma, M. 2018a. Extreme multi-label learning with label features for warm-start tagging, ranking & recommendation. In *Proceedings of the Eleventh ACM International Conference on Web Search and Data Mining*, 441–449. ACM.
- Prabhu, Y.; Kag, A.; Harsola, S.; Agrawal, R.; and Varma, M. 2018b. Parabel: Partitioned label trees for extreme classification with application to dynamic search advertising. In *Proceedings of the 2018 World Wide Web Conference on World Wide Web*, 993–1002. International World Wide Web Conferences Steering Committee.
- Tagami, Y. 2017. AnnexML: approximate nearest neighbor search for extreme multi-label classification. In *Proceedings of the 23rd ACM SIGKDD International Conference on Knowledge Discovery and Data Mining*, 455–464. ACM.
- Yen, I. E.-H.; Huang, X.; Ravikumar, P.; Zhong, K.; and Dhillon, I. 2016. PD-Sparse: a primal and dual



sparse approach to extreme multiclass and multilabel classification. In *International Conference on Machine Learning*, 3069–3077.

Yen, I. E.; Huang, X.; Dai, W.; Ravikumar, P.; Dhillon, I.; and Xing, E. 2017. PPDsparse: a parallel primal-dual sparse method for extreme classification. In *Proceedings of the 23rd ACM SIGKDD International Conference on Knowledge Discovery and Data Mining*, 545–553. ACM.

Zubiaga, A. 2012. Enhancing navigation on wikipedia with social tags. *arXiv preprint arXiv:1202.5469*.