

Active Secure Coding Based on Eavesdropper Behavior Learning

Yizhi Zhao

Abstract

The secrecy capacity achieving problem of the wiretap channel against an active eavesdropper with unlimited computational power over is an important foresighted task for secure communication. For active wiretap channel, the effectiveness of cryptography embedded secure coding schemes are limited due to the passive problem of physical layer coding. Thus in this paper, a novel solution called active secure coding scheme is proposed which combines physical secure coding with machine learning to implement an active defense against the active eavesdropper.

To construct an universal active method for secure coding, an abstract active wiretap channel model is constructed under the detectable precondition, in which hidden Markov model is employed to build the internal eavesdropper behavior pattern (the stochastic process for eavesdropper behavior states) with stochastically mapped external observations. Based on the abstract model, an eavesdropper behavior pattern learning and eavesdropper behavior states decoding are constructed for estimating the optimal eavesdropper behavior states, which enables the secure coding scheme to respond the eavesdropper actively. Then this active secure coding method is performed to the general varying wiretap channel to construct an explicit active secure polar coding scheme. As proofed, the proposed active secure polar coding scheme can theoretically achieve the average secrecy capacity of t times secure transmissions under the reliability and strong security criterions.

Index Terms

active wiretap channel, active secure coding scheme, eavesdropper behavior learning, polar code, hidden Markov model.

I. INTRODUCTION

With the development of quantum computing technology, rapidly growing computation power has already threatened the security of computing complexity based cryptography [1], [2]. Thus, in near future, when eavesdropper obtains extremely high level of computational power, issue of

confidential communication without cryptographic schemes will be an important and practical problem. One decent solution for this foresighted problem is physical layer secure coding which was proposed by Wyner in 1975 with his *Wiretap Channel (WTC)* model [3]. Because of its information-theoretic security, secure coding scheme can provide secure and reliable communication without encryption.

In the last decade, polar code [4] based secure coding schemes had achieved secrecy capacities of Wyner's WTC [5], [6] and several other extended WTC models [7]–[10] under the security and reliability criterions. But these secure coding schemes are all designed under a setting that eavesdropper can only passively wiretapping without any initiative changes, generalized as *Passive Wiretap Channel (P-WTC)*, which is however too idealized.

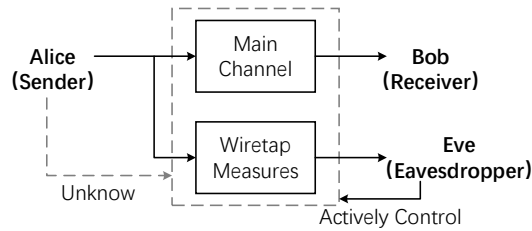

Fig. 1. Active Wiretap Channel. Symbols and encoding/decoding processes are not shown.

On the contrary, for more practical category of WTC, the *Active Wiretap Channel (A-WTC)*, physical layer secure coding schemes are however no longer effective. As illustrated in Fig. 1, in A-WTC whole WTC is under the control of an active eavesdropper with various wiretapping measures, such as selectively reading (WTC-II [11]), selectively writing (Adversarial WTC [12]), channel status changing (Arbitrary Varying WTC [13]), while in many cases, channels and wiretapping status are unknown to the legitimate users [14]. Since physical layer coding can only be constructed on a fixed status of channels and defense *passively*, it is hard for the *passive secure coding scheme* to cover the constantly changed active eavesdropping in A-WTC.

One commonly adapted modification method for A-WTC secure scheme construction is the combination of cryptography and physical layer secure coding [12], [15], [16] which is unfortunately unapplicable to the unlimited computational condition. Besides, even though cryptography can add adaptability to the secure scheme to some extents, the essentially *passive* problem of physical layer coding remains unsolved. Thus, when the range of active-eavesdropping behavior is expanded or the type of eavesdropping behavior is changed, the effectiveness of encrypted

secure coding schemes will be vanished.

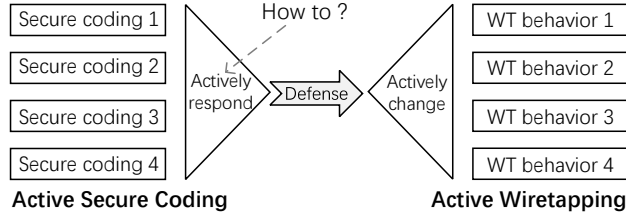

Fig. 2. The idea of active secure coding scheme.

In the aim of constructing an efficient secure coding scheme for A-WTC, the essentially *passive* problem must be solved. Thus, in this paper, we present a novel idea called *active secure coding scheme*. As illustrated in Fig. 2, instead of passively defense with a fix secure coding, active secure coding scheme is designed to respond to the active changes of wiretap behavior and adjust the secure coding actively. The core issue of designing an active secure coding scheme is how to respond the active changes of A-WTC correctly.

In 2007, A middle ground *detectable precondition* was presented in [17] when constructing an A-WTC encrypted secure coding scheme, which is also precisely useful to our active secure coding issue.

Definition 1 (*Detectable precondition [17]*) *In A-WTC active modification of eavesdropper may induce some physical effects in the environment that can be detected by legitimate parties.*

Based on the detectable precondition, the general idea of our active secure coding scheme is as follow:

- i. Learn the active eavesdropper behavior pattern of eavesdropper from the observed information;
- ii. Decode or predict the eavesdropper behavior state from the observed information according to the learned behavior pattern;
- iii. Construct or modify the optimal physical layer coding scheme corresponding to the decoded eavesdropper behavior state.

Thus, in this paper, we construct an active secure coding scheme as a novel solution for the foresighted problem of confidential communication over A-WTC with unlimited computation power. *Specifically, under the detectable precondition, we use models and algorithms of machine*

learning to construct the eavesdropper behavior pattern learning and state decoding, which is positively related to the unlimited computation power; we use polar code to construct the secure coding.

The outline of this paper is as follow. Section II presents the notations and construct a abstract model of detectable A-WTC. Section III presents the construction of the machine learning based universal active secure coding scheme for abstract detectable A-WTC. Section IV presents the construction of active secure polar coding scheme for general varying WTC. Finally, Section V concludes the paper.

II. ABSTRACT MODEL OF DETECTABLE A-WTC

Notation: We define the integer interval $\llbracket a, b \rrbracket$ as the integer set between $\lfloor a \rfloor$ and $\lceil b \rceil$. For $n \in \mathbb{N}$, define $N \triangleq 2^n$. Denote X, Y, Z, \dots random variables (RVs) taking values in alphabets $\mathcal{X}, \mathcal{Y}, \mathcal{Z}, \dots$ and the sample values of these RVs are denoted by x, y, z, \dots respectively. Then p_{XY} denotes the joint probability of X and Y , and p_X, p_Y denotes the marginal probabilities. Also we denote a N size vector $X^N \triangleq (X_1, X_2, \dots, X_N)$, denote $X_a^b \triangleq (X_a, X_{a+1}, \dots, X_b)$. And for any index set $\mathcal{A} \subseteq \llbracket 1, N \rrbracket$, we define $X^{\mathcal{A}} \triangleq \{X_i\}_{i \in \mathcal{A}}$. For the polar codes, we denote \mathbf{G}_N the generator matrix, \mathbf{R} the bit reverse matrix, $\mathbf{F} = \begin{bmatrix} 1 & 0 \\ 1 & 1 \end{bmatrix}$, \otimes the Kronecker product, and have $\mathbf{G}_N = \mathbf{R}\mathbf{F}^{\otimes n}$.

In order to design an universal active secure coding scheme, first we have to construct an abstract A-WTC model with the detectable precondition. Thus in this section, we present a new construction method for abstract A-WTC model, as the state based A-WTC. In the abstract model, active behavior of eavesdropper is described by the abstract behavior state without any details. Considering the following definitions.

Definition 2 (*Eavesdropper behavior state, EB state*) Denote S the abstract expression of EB state with alphabet $\mathcal{S} = \{s_1, s_2, s_3, \dots\}$, and the state value of s abstractly represents the main channel condition and wiretapping approaches. e.g., for original WTC, $\mathcal{S} = \{s_1\}$, $s_1 = (p_{X|Y}, p_{X|Z})$. For A-WTC, time sequence s_1, s_2, s_3, \dots represents the actively changing of the EB, and the internal relation between each states is denoted as the EB pattern.

Definition 3 (*Observed information*) Denote O the observed information detected by the legitimate users, with alphabet $\mathcal{O} = \{\mathbf{o}1, \mathbf{o}2, \mathbf{o}3, \dots\}$. The observed value o is related to the value of EB state s .

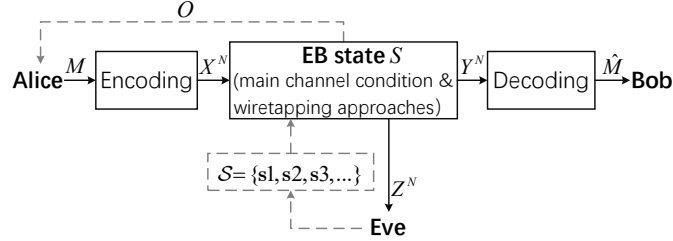

Fig. 3. EB state based abstract detectable A-WTC.

With the EB state S and observed information O , the discrete memoryless abstract detectable A-WTC is construct as $(\mathcal{X}, \mathcal{Y}, \mathcal{Z}, \mathcal{S}, \mathcal{O})$ with two legitimate users Alice and Bob and an active eavesdropper Eve, as illustrated in Fig. 3.

- **Eve:** actively choose the EB state $S \in \mathcal{S}$ which contains the main channel condition as $p_{X|Y}$ and the wiretapping approaches. Obtains Z^N from the channel according to S .
- **Alice:** encode M into X^N and transmit to Bob over the EB state S . Receive the observed information O when EB state is changing.
- **Bob:** receive Y^N from Alice over the EB state S and decodes it into estimated \hat{M} .

Definition 4 For abstract detectable A-WTC with EB state si , the secrecy capacity is characterized as

$$C_s(si) = \max_{M \rightarrow U \rightarrow X \rightarrow Y, Z} [I(U; Y|si) - I(U; Z|si)] \quad (1)$$

For the construction of abstract detectable A-WTC, the only restricted assumption is

$$\forall si \in \mathcal{S}, C_s(si) > 0 \quad (2)$$

which guarantees the implementation of the physical layer secure coding. For every state value $si \in \mathcal{S}$, define a correspondent N length code as follow.

Definition 5 Denote a $(2^{NR}, N)$ code ci for the state value $si \in \mathcal{S}$, with messages $M \in \mathcal{M} = \llbracket 1, 2^{NR} \rrbracket$ and random source \mathcal{R} with arbitrary distribution. Then have

- the encoding function:

$$\mathbb{F}(\mathbf{s}i) : \mathcal{M} \times \mathcal{R} \rightarrow \mathcal{X}^N \quad (3)$$

- the decoding function with error bits “?”

$$\mathbb{G}(\mathbf{s}i) : \mathcal{Y}^N \rightarrow \mathcal{M} \times \{?\} \quad (4)$$

The performance of a code $\mathbf{c}i$ is defined as

- error probability:

$$P_e(\mathbf{s}i, \mathbf{c}i) = \Pr(M \neq \hat{M} | \mathbf{s}i, \mathbf{c}i) \quad (5)$$

- information leakage to Eve:

$$L(\mathbf{s}i, \mathbf{c}i) = I(Z^N; M | \mathbf{s}i, \mathbf{c}i) \quad (6)$$

Definition 6 For state $\mathbf{s}i$, rate R is achievable if sequence of code $\mathbf{c}i$ exists under any of the criterions listed below:

- reliability criterion:

$$\lim_{N \rightarrow \infty} P_e(\mathbf{s}i, \mathbf{c}i) = 0 \quad (7)$$

- weak security criterion:

$$\lim_{N \rightarrow \infty} \frac{1}{N} L(\mathbf{s}i, \mathbf{c}i) = 0 \quad (8)$$

- strong security criterion:

$$\lim_{N \rightarrow \infty} L(\mathbf{s}i, \mathbf{c}i) = 0 \quad (9)$$

Remark 1 Reliability and security criterions are measures for evaluating the performance of a code $\mathbf{c}i$. Reliability can be achieved with a vanishing error probability of decoding the messages. Weak security can be achieved with a vanishing information leakage rate. And strong security can be achieved with a vanishing information leakage.

III. UNIVERSAL ACTIVE SECURE CODING SCHEME

In this section, we construct an universal active secure coding scheme on the EB state based abstract detected A-WTC, as illustrated in Fig. 4.

Our construction of universal active secure coding scheme contains four procedures:

- Establish a stochastic model for the EB state S as the EB pattern, with relationship to the internal observed information O ;

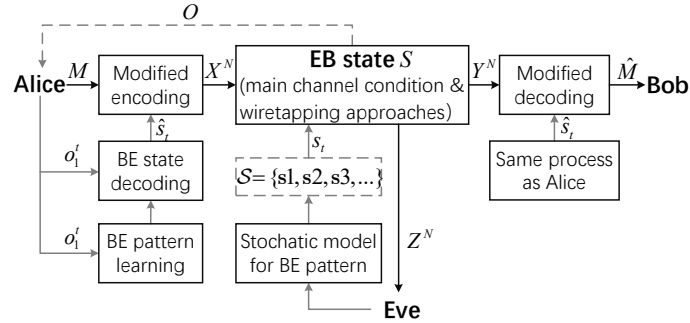

Fig. 4. Structure of universal active secure coding scheme

- ii. Construct a learning process of the EB pattern from the observed information O by using machine learning algorithms;
- iii. Construct a decoding process of the EB state S from the observed information O with learned EB pattern by using machine learning algorithms;
- iv. Design a modification method for secure coding based on the decoded EB state S .

A. Model Construction for EB Pattern and Observed Information

Make the following assumptions.

- Assume that the active EB pattern is a stochastic process that can be expressed by stochastic models;
- Assume that legitimate users know S and O ;
- Assume that the correspondence between EB state value and observation value is not one to one, otherwise EB state can be directly identified from the observed information.

Based on the assumptions above, we build the EB pattern and observation by using *Hidden Markov Model (HMM)* [18]. As illustrated in Fig 5, the basic HMM contains two parts, a hidden internal part which is a Markov process of hidden states, and an external observation part for observing the emission information with probability correlation to the current hidden state. The structure of HMM can nicely match our state based detectable A-WTC model.

Active model construction:

Consider an HMM $(S, O, \mathbf{A}, \mathbf{B}, \pi)$ with parameter set $\lambda = (\mathbf{A}, \mathbf{B}, \pi)$. The corresponding relations between the detectable A-WTC and HMM are as follow.

- Alphabet $S = \{s1, s2, s3, \dots\}$ of the EB state equals to the state set S of HMM, denote $|S| = \alpha$;

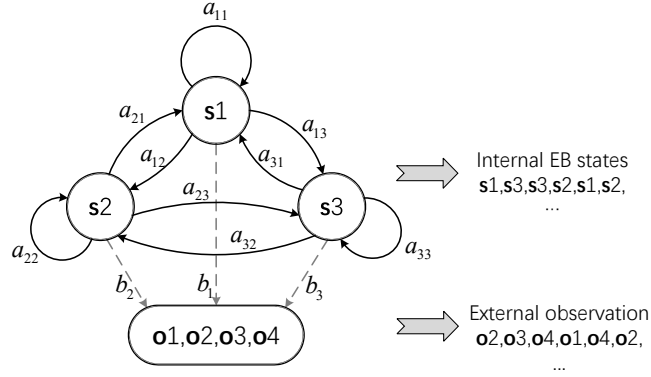

Fig. 5. The basic Hidden Markov Model. 1-HMM with state set $\mathcal{S} = \{s1, s2, s3\}$ and observation set $\mathcal{O} = \{o1, o2, o3, o4\}$, a_{ij} is the transparent probability from state si to s_j , b_i is the $1 \times |\mathcal{O}|$ emission probability matrix from state si to \mathcal{O} .

- Alphabet $\mathcal{O} = \{o1, o2, o3, \dots\}$ of the detected information equals to the observation set \mathcal{O} of HMM, denote $|\mathcal{O}| = \gamma$;
- Matrix \mathbf{A} is a $\alpha \times \alpha$ state transparent probability matrix of the internal Markov process of HMM, for $i \in \llbracket 1, \alpha \rrbracket$ have

$$\mathbf{A} = (a_{ij})_{\alpha \times \alpha}, \quad a_{ij} = p(s_j | s_i) \quad (10)$$

- Matrix \mathbf{B} is a $\alpha \times \gamma$ emission probability matrix of HMM from \mathcal{S} to \mathcal{O} , for $i \in \llbracket 1, \alpha \rrbracket$, $j \in \llbracket 1, \gamma \rrbracket$ have

$$\mathbf{B} = (b_{ij})_{\alpha \times \gamma}, \quad b_{ij} = p(o_j | s_i) \quad (11)$$

- π is a $1 \times \alpha$ probability matrix for the initial state S_1 when $t = 1$, have

$$\pi = [p(S_1 = s1), p(S_1 = s2), p(S_1 = s3), \dots]_{1 \times \alpha} \quad (12)$$

Generally, denote \mathbb{M} the internal Markov process of HMM. For $t = 1$, define $S_1 = \mathbb{M}(\pi)$; for $t > 1$,

$$S_t = \mathbb{M}(S_1^{t-1}, \mathbf{A}) \stackrel{(a)}{=} \mathbb{M}(S_{t-1}, \mathbf{A}), \quad S \in \mathcal{S} \quad (13)$$

where (a) is for the first-order Markov model (1-HMM) case. Denote \mathbb{E} the external emission process, then have

$$O_t = \mathbb{E}(S_t, \mathbf{B}), \quad O \in \mathcal{O}, \quad S \in \mathcal{S} \quad (14)$$

Remark 2 In the proposed model construction with 1-HMM, the EB pattern is described by a first-order Markov model which is a basic stochastic model. In case for more practical needs,

high-order Markov model or other better stochastic models can be applied to enhance the model accuracy but will also increase the calculating complexity. As in 1-HMM, we simply use the emission probability to establish the correlation between EB state and detected information. In more complex cases, connections between each observations can be modified.

Theorem 1 (Squared prediction error [23], [24]) *Let V be the variable that we trying to predict, and Q be the covariates. Assume a relationship as*

$$V = f(Q) + \epsilon \quad (15)$$

where ϵ is the error term that normally distributed with a mean of zero, e.g. $\epsilon \sim \mathcal{N}(0, \sigma_\epsilon)$. Then for an estimate model $\hat{f}(Q)$ of $f(Q)$, the expected squared prediction error at point q is

$$Err(q) = E \left[(V - \hat{f}(q))^2 \right] \quad (16)$$

and can be decomposed into bias and variance components as

$$Err(q) = \left(E[\hat{f}(q) - f(q)] \right)^2 + E \left[\left(\hat{f}(q) - E[\hat{f}(q)] \right)^2 \right] + \sigma_\epsilon^2 \quad (17)$$

in the form of

$$Err(q) = \text{Bias}^2 + \text{Variance} + \text{Irreducible Error} \quad (18)$$

where the irreducible error is the noise term in the true relationship. In practical cases with imperfect model and finite data, there is a tradeoff between minimizing the bias and minimizing the variance. Considering a theoretically case with vanished noise, true model and infinite data for calibration, both the bias and variance terms can be reduced to 0.

B. EB Pattern Learning

To construct the active secure coding scheme, firstly we implement the learning procedure of the EB pattern from the observed information. Considering the HMM based model construction for detectable A-WTC, the issue of EB pattern learning can be turned into the learning of the HMM parameter set $\lambda = (\mathbf{A}, \mathbf{B}, \pi)$ from the observation time sequence O_1^t which is the training data.

EB pattern learning: considering t -times transmissions, with parameter set λ for the stochastic model of EB pattern and observation, EB state $S \in \mathcal{S}$ and observation sequence O_1^t , $O \in \mathcal{O}$, the EB pattern learning process \mathbb{L} is to learn the optimal estimated $\hat{\lambda}$ from training data O_1^t , as

$$\hat{\lambda} = \mathbb{L}(O_1^t, \mathcal{S}, \mathcal{O}) \quad (19)$$

have for $t \rightarrow \infty, \forall \epsilon_1, 0 < \epsilon_1 < 1, \exists \mathbb{L}$, that

$$P_e(\mathbb{L}) = \Pr(\hat{\lambda} \neq \lambda | \mathbb{L}) < \epsilon_1 \quad (20)$$

Thus for the HMM $(\mathcal{S}, \mathcal{O}, \mathbf{A}, \mathbf{B}, \pi)$, the learning process is

$$(\hat{\mathbf{A}}, \hat{\mathbf{B}}, \hat{\pi}) = \mathbb{L}(O_1^t, \mathcal{S}, \mathcal{O}) \quad (21)$$

To learn the optimal estimated parameter set of HMM, we can apply the Baum-Welch algorithm [18], as in Appendix A.

C. EB state Decoding

Based on the learned EB pattern and the observation correlation, specifically the optimal estimated parameter set $\hat{\lambda}$, we can decoding the observation O_1^t to obtain the estimated EB state time sequence \hat{S}_1^t .

EB state decoding: considering t -times transmissions, with parameter set λ for the stochastic model of EB pattern and observation, EB state $S \in \mathcal{S}$ and observation sequence $O_1^t, O \in \mathcal{O}$, the EB state decoding process \mathbb{D} is the process to decode the optimal estimated \hat{S}_1^t from training data O_1^t , as

$$\hat{S}_1^t = \mathbb{D}(O_1^t, \hat{\lambda}, \mathcal{S}, \mathcal{O}) \quad (22)$$

have for $t \rightarrow \infty, \forall \epsilon_2, 0 < \epsilon_2 < 1, \exists \mathbb{D}$, that

$$P_e(\mathbb{D}) = \Pr(\hat{S}_1^t \neq S_1^t | \mathbb{D}) < \epsilon_2 \quad (23)$$

Thus for the HMM $(\mathcal{S}, \mathcal{O}, \mathbf{A}, \mathbf{B}, \pi)$, the decoding process is

$$\hat{S}_1^t = \mathbb{D}(O_1^t, \hat{\mathbf{A}}, \hat{\mathbf{B}}, \hat{\pi}, \mathcal{S}, \mathcal{O}) \quad (24)$$

To decode the optimal estimated EB state sequence of HMM, we can apply the Viterbi algorithm [19], as in Appendix B.

D. Modification Method for Secure Coding

Considering two different cases for the detectable A-WTC,

- *Non-delay A-WTC:* in this case, the actively changing of EB states is ahead of the encoding process. Thus before secure encoding process of t -th time transmission, legitimate users can observe O_1^t and directly decoding the estimated \hat{S}_1^t for t -th communication.

- *Delay A-WTC*: in this case, the actively changing of EB states is after the encoding process. For t -th time transmission, legitimate users can only observe O_1^{t-1} and decoding S_1^{t-1} before the secure coding process, thus there is an additional time series prediction problem for \hat{S}_t . In this paper, we study the non-delay case, and leave the delay case for future researches.

Optional secure coding: For each EB state value $si \in \mathcal{S}$, assume a correspondent physical layer secure coding ci as defined in Definition 5, and obtain the secure coding set $\mathcal{C} = \{c1, c2, \dots, c\alpha\}$ which satisfies both reliability (7) and strong security criterion (9). Therefore for the abstract detectable A-WTC, after obtaining $\hat{S}_t \in \mathcal{S}$ from the observation O_1^t by EB pattern learning and states decoding, one can directly choose secure code $\hat{C}_t \in \{c1, c2, \dots, c\alpha\}$ that corresponds to \hat{S}_t .

In order to learn a relatively stable initial EB pattern for decoding the EB state and maintaining security at the beginning of the secure communication, we installing a pre-learning stage for initial training data collection.

Pre-learning stage: Setting a ω rounds transmissions prior to the secure communication as the pre-learning stage, in which legitimate users only transmit uncoded random bits. So that legitimate parties can collect enough observations from the changing of EB states without any information leakage. Observations of pre-learning stage are defined as O_ω .

E. Performance Analyses

Definition 7 Denote symbol \vee as match and symbol \wedge as unmatched. e.g. for $\mathcal{S} = \{s1, s2, \dots, s\alpha\}$ and $\mathcal{C} = \{c1, c2, \dots, c\alpha\}$, have $si \vee cj$ if $i = j$, $si \wedge cj$ if $i \neq j$.

Thus for i -th time secure transmission, $i \in \llbracket 1, t \rrbracket$, when $N \rightarrow \infty$, assume

- secrecy rate

$$\begin{aligned} R_s(S_i, \hat{C}_i) &\leq C_s(S_i), \text{ if } s_i \vee \hat{c}_i \\ R_s(S_i, \hat{C}_i) &= 0, \text{ if } s_i \wedge \hat{c}_i \end{aligned} \tag{26}$$

- error probability

$$\begin{aligned} P_e(S_i, \hat{C}_i) &= \Pr(M \neq \hat{M} | S_i, \hat{C}_i) \\ &= \begin{cases} 0, & \text{if } s_i \vee \hat{c}_i \\ 1, & \text{if } s_i \wedge \hat{c}_i \end{cases} \end{aligned} \quad (28)$$

- information leakage

$$\begin{aligned} L(S_i, \hat{C}_i) &= I(M; Z^N | S_i, \hat{C}_i) \\ &= \begin{cases} 0, & \text{if } s_i \vee \hat{c}_i \\ 1, & \text{if } s_i \wedge \hat{c}_i \end{cases} \end{aligned} \quad (30)$$

For each time of secure transmission, if \hat{C}_i matches EB state S_i , then transmission achieves security and reliability; if \hat{C}_i does not match EB state S_i , we assume that neither security nor reliability is achieved. Based on these setting, we analyze the average performance of t times independent secure communications.

Definition 8 Separate $\llbracket 1, t \rrbracket$ into two sets $t(\vee)$ and $t(\wedge)$, where $t(\vee)$ is the numbers of times that \hat{C}_i matches S_i , with set length t_\vee , and $t(\wedge)$ is the numbers of times that \hat{C}_i dose not match S_i , with set length t_\wedge . From (23), for $(t + \omega) \rightarrow \infty$, have $t_\vee/t = 1 - \epsilon_2$ and $t_\wedge/t = \epsilon_2$.

Proposition 1 (Secrecy rate, reliability and security) For the abstract detectable A-WTC, the proposed universal active secure coding scheme can achieve the average secrecy capacity of t time secure communication under the reliability and strong security criterions, when $N \rightarrow \infty$ and $(t + \omega) \rightarrow \infty$.

Proof: Denote $\bar{\mathbf{R}}_s$ the average secrecy rate for t times secure transmission with $N \rightarrow \infty$, have

$$\begin{aligned} \bar{\mathbf{R}}_s &= \frac{1}{t} \sum_{i=1}^t \mathbf{R}_s(S_i, \hat{C}_i) \\ &= \frac{1}{t} \left[\sum_{t(\vee)} \mathbf{R}_s(S_i \vee \hat{C}_i) + \sum_{t(\wedge)} \mathbf{R}_s(S_j \wedge \hat{C}_j) \right] \\ &= \frac{1}{t} \sum_{t(\vee)} \mathbf{R}_s(S_i \vee \hat{C}_i) \\ &\leq \frac{1}{t} \sum_{t(\vee)} C_s(S_i) \stackrel{(b)}{\leq} \bar{C}_s \end{aligned} \quad (32)$$

where \bar{C}_s is the average secrecy capacity of t times secure transmission, and the equal holds for (b) when $(t + \omega) \rightarrow \infty$ that ϵ_2 is vanished.

Denote \mathbf{P}_e the error probability for t times secure transmission, have

$$\mathbf{P}_e = \Pr(M_1^t \neq \hat{M}_1^t) = \frac{\sum_{t(\wedge)} |M_j|}{\sum_{i=1}^t |M_i|} \quad (33)$$

For $N \rightarrow \infty$, assume $|M_i|$ of each time are the same, then have

$$\mathbf{P}_e = \frac{t_\wedge}{t} = \epsilon_2 \quad (34)$$

Thus \mathbf{P}_e is vanished for $(t + \omega) \rightarrow \infty$.

Denote \mathbf{L} the information leakage (strong security) for t times secure transmission, have

$$\begin{aligned} \mathbf{L} &= I[M_1^t; (Z^N)_1^t] \\ &\stackrel{(c)}{=} \sum_{i=1}^t I[M_i; (Z^N)_i] \\ &= \sum_{t(\vee)} I[M_i; (Z^N)_i | S_i \vee \hat{C}_i] + \sum_{t(\wedge)} I[M_j; (Z^N)_j | S_j \wedge \hat{C}_j] \\ &= t_\wedge = \epsilon_2 t \end{aligned} \quad (36)$$

where (c) is because transmissions of each times are independent. Thus \mathbf{L} is vanished for $(t + \omega) \rightarrow \infty$ and $N \rightarrow \infty$. ■

IV. ACTIVE SECURE POLAR CODING SCHEME FOR GENERAL VARYING WTC

In this section, we perform our universal active secure coding to a specific A-WTC, the *General Varying WTC (GV-WTC)*, and construct an explicit active secure polar coding scheme.

A. The General Varying WTC

Varying Wiretap Channel, with another name *Compound Wiretap Channel* in [14], is an A-WTC that the actual channel realization is controlled and shifted by the eavesdropper and unknown to the legitimate users, as illustrated in Fig. 6. In the model, the channel realization remains constant during the N length codeword transmission at each rounds, and legitimate parties knows the entire set of possible channel realizations. *In this paper, we discuss the general case of Varying WTC in which both main channel and wiretap channel are asymmetric with no degraded relations.*

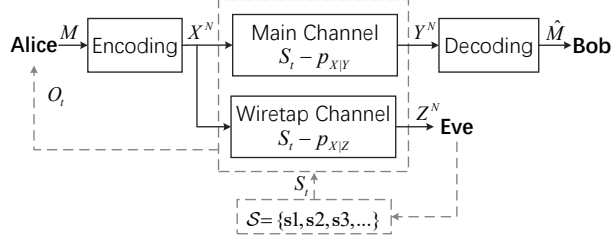

Fig. 6. The General Varying WTC with observation.

Definition 9 The HMM based discrete memoryless General Varying Wiretap Channel with observation is defined as $(\mathcal{X}, \mathcal{Y}, \mathcal{Z}, \mathcal{S}, \mathcal{O}, \mathbf{A}, \mathbf{B}, \pi)$, where $\mathcal{S} = \{s_1, s_2, \dots, s_\alpha\}$, $\mathcal{O} = \{o_1, o_2, \dots, o_\gamma\}$, $\lambda = (\mathbf{A}, \mathbf{B}, \pi)$. For $s_i \in \mathcal{S}$, $s_i = p_{Y^N Z^N | X^N}^{(i)}$ which have:

$$\forall (x^N, y^N, z^N) \in \mathcal{X}^N \times \mathcal{Y}^N \times \mathcal{Z}^N, \quad (38)$$

$$p_{Y^N Z^N | X^N}(y^N, z^N | x^N) = \prod_{j=1}^N p_{Y^N Z^N | X^N}^{(i)}(y_j, z_j | x_j)$$

For HMM based EB pattern and observation, $O \in \mathcal{O}$, $S \in \mathcal{S}$, have

- EB pattern:

$$S_1 = \mathbb{M}(\pi), \quad S_t = \mathbb{M}(S_1^{t-1}, \mathbf{A}) \quad (39)$$

- observation:

$$O_t = \mathbb{E}(S_t, \mathbf{B}) \quad (40)$$

For every EB states of GV-WTC, the secrecy capacity $C_s(s_i)$ is the same as Definition 1, the reliability and security criterions are the same as Definition 6.

Theorem 2 [14] For the GV-WTC, under the strong security criterion, the universal secrecy capacity C_{us} with \mathcal{S} is bounded by

$$C_{us}(\mathcal{S}) \geq \max_{M \rightarrow U \rightarrow X \rightarrow Y, Z} \left[\min_{\mathcal{S}} I(U; Y) - \max_{\mathcal{S}} I(U; Z) \right]$$

$$C_{us}(\mathcal{S}) \leq \min_{\mathcal{S}} \max_{M \rightarrow U \rightarrow X \rightarrow Y, Z} [I(U; Y) - I(U; Z)] \quad (42)$$

$$= \min_{\mathcal{S}} C_s(s_i)$$

B. Active Secure Polar Coding Scheme

To construct the active secure coding scheme, first we need to build a correspondent secure polar coding for each EB state $s_i \in \mathcal{S}$.

Definition 10 (*Bhattacharyya parameter*) Consider a pair of random variables (X, Y) with joint distribution $p_{X|Y}$, where X is a binary random variable and Y is a finite-alphabet random variable. To measure the amount of randomness in X given Y , the Bhattacharyya parameter is defined as

$$Z(X|Y) = 2 \sum_{y \in \mathcal{Y}} p_Y(y) \sqrt{p_{X|Y}(0|y)p_{X|Y}(1|y)} \quad (43)$$

Polar subset division for s_i :

Consider $s_i = p_{YZ|X}^{(i)}$, $i \in \llbracket 1, \alpha \rrbracket$, $\beta \in (0, 1/2)$, $\delta_N = 2^{-N^\beta}$, assume knowing the optimal distribution of channel inputs to achieve the channel capacity under $p_{Y|X}^{(i)}$, then have

- source polarization

$$\begin{aligned} \mathcal{H}_X^{(i)} &= \{j \in \llbracket 1, N \rrbracket : Z(U_j|U_1^{j-1}) \geq 1 - \delta_N\} \\ \mathcal{L}_X^{(i)} &= \{j \in \llbracket 1, N \rrbracket : Z(U_j|U_1^{j-1}) \leq \delta_N\} \end{aligned} \quad (45)$$

- main channel polarization

$$\begin{aligned} \mathcal{H}_{X|Y}^{(i)} &= \{j \in \llbracket 1, N \rrbracket : Z(U_j|U_1^{j-1}, Y^N) \geq 1 - \delta_N\} \\ \mathcal{L}_{X|Y}^{(i)} &= \{j \in \llbracket 1, N \rrbracket : Z(U_j|U_1^{j-1}, Y^N) \leq \delta_N\} \end{aligned} \quad (47)$$

- wiretap channel polarization

$$\begin{aligned} \mathcal{H}_{X|Z}^{(i)} &= \{j \in \llbracket 1, N \rrbracket : Z(U_j|U_1^{j-1}, Z^N) \geq 1 - \delta_N\} \\ \mathcal{L}_{X|Z}^{(i)} &= \{j \in \llbracket 1, N \rrbracket : Z(U_j|U_1^{j-1}, Z^N) \leq \delta_N\} \end{aligned} \quad (49)$$

- subset divisions of index N

$$\begin{aligned} \mathcal{I}^{(i)} &= \mathcal{H}_X^{(i)} \cap \mathcal{L}_{X|Y}^{(i)} \cap \mathcal{H}_{X|Z}^{(i)} \\ \mathcal{F}^{(i)} &= \mathcal{H}_X^{(i)} \cap \left(\mathcal{L}_{X|Y}^{(i)}\right)^c \cap \mathcal{H}_{X|Z}^{(i)} \\ \mathcal{R}^{(i)} &= \mathcal{H}_X^{(i)} \cap \mathcal{L}_{X|Y}^{(i)} \cap \left(\mathcal{H}_{X|Z}^{(i)}\right)^c \\ \mathcal{B}^{(i)} &= \mathcal{H}_X^{(i)} \cap \left(\mathcal{L}_{X|Y}^{(i)}\right)^c \cap \left(\mathcal{H}_{X|Z}^{(i)}\right)^c \\ \mathcal{D}^{(i)} &= \left(\mathcal{H}_X^{(i)}\right)^c \end{aligned} \quad (51)$$

assume $|\mathcal{I}^{(i)}| > \max_S |\mathcal{B}|$, then construct a subset $\mathcal{E}^{(i)}$ that satisfies

$$\mathcal{E}^{(i)} \subset \mathcal{I}^{(i)}, \quad |\mathcal{E}^{(i)}| = \max_S |\mathcal{B}| \quad (52)$$

Remark 3 For each $s_i = p_{YZ|X}^{(i)}$, subset $\mathcal{I}^{(i)} \setminus \mathcal{E}^{(i)}$ is secure and reliable, which is for information bits; subset $\mathcal{E}^{(i)}$, with a fixed size for all s_i , is secure and reliable, which is for functional random bits; subset $\mathcal{F}^{(i)}$ is secure but unreliable, which is for frozen bits; subset $\mathcal{R}^{(i)}$ is reliable but insecure, which is for uniformly distributed random bits; subset $\mathcal{B}^{(i)}$ is neither secure nor reliable, thus which is constructed to retransmit the random bits in $\mathcal{E}^{(i)}$ of last round; subset $\mathcal{D}^{(i)}$ is for deterministic bits calculated by

$$u_j = \arg \max_{u \in \{0,1\}} p_{U_j|U_1^{j-1}}(u|u_1^{j-1}), \quad j \in \mathcal{D}^{(i)} \quad (53)$$

Now we introduce the structure of our active secure polar coding scheme for GV-WTC.

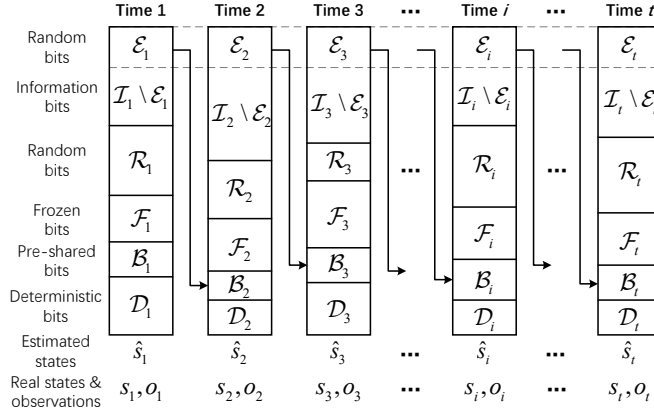

Fig. 7. The structure of active secure polar coding scheme.

Active secure polar coding scheme:

The secure coding structure of t time secure communications is illustrated in Fig. 7, which is a modified and extended multi-block chaining structure. For non-delay GV-WTC $(\mathcal{X}, \mathcal{Y}, \mathcal{Z}, \mathcal{S}, \mathcal{O}, \lambda)$ and confidential message $M \in \mathcal{M}$, assuming legitimate parties know the full set of \mathcal{S}, \mathcal{O} , then the active secure polar coding scheme is as follow.

- i. Pre-learning stage: same as the secure structure for abstract A-WTC, we set a pre-learning stage with ω rounds random transmission before the t times secure communications, with observations as o_ω .
- ii. EB pattern learning: for i -th time secure communication, $i \in \llbracket 1, t \rrbracket$, with observations as o_1^i , the learning process is

$$\hat{\lambda}_i = \mathbb{L}(o_\omega, o_1^i, \mathcal{S}, \mathcal{O}) \quad (54)$$

- iii. EB state decoding: for i -th time, with $\hat{\lambda}_i$, decoding the optimal estimated state sequence \hat{s}_1^i by

$$\hat{s}_1^i = \mathbb{D}(o_\omega, o_1^t, \hat{\lambda}_i, \mathcal{S}, \mathcal{O}) \quad (55)$$

- iv. Subsets division: for i -th time, based on the optimal estimated EB state \hat{s}_i , perform the polar subsets division of index N , and obtain $(\hat{\mathcal{L}}_i, \hat{\mathcal{F}}_i, \hat{\mathcal{R}}_i, \hat{\mathcal{B}}_i, \hat{\mathcal{D}}_i, \hat{\mathcal{E}}_i)$.
- v. Encoding: for i -th time, make the following assignment to u^N :

- $u^{\hat{\mathcal{L}}_i \setminus \hat{\mathcal{E}}_i}$: assigned with information bits of M_i ;
- $u^{\hat{\mathcal{F}}_i}$: assigned with frozen bits;
- $u^{\hat{\mathcal{R}}_i}$: assigned with uniformly distributed random bits;
- $u^{\hat{\mathcal{E}}_i}$: assigned with uniformly distributed random bits;
- $u^{\hat{\mathcal{D}}_i}$: assigned with deterministic bits calculated by (53);
- $u^{\hat{\mathcal{B}}_i}$: if $i = 1$, assigned with a pre-shared random bits; if $i > 1$, assigned with the first $|\hat{\mathcal{B}}_i|$ bits of $u^{\hat{\mathcal{E}}_{i-1}}$ in time $i - 1$.

Then encode u^N into the optimally distributed channel input x^N by polar encoding $x^N = u^N \mathbf{G}_N$, and transmit x^N over the channel.

- vi. Decoding: for i -th time, legitimate user Bob receives y^N and decodes it into the estimated \hat{u}^N by using the successive cancelation decoding [4].

- for $j \in \hat{\mathcal{L}}_i \cup \hat{\mathcal{R}}_i$,

$$\hat{u}_j = \arg \max_{u \in \{0,1\}} p_{U_j | U_1^{j-1} Y^N} (u | \hat{u}_1^{j-1} y^N) \quad (56)$$

- for $j \in \hat{\mathcal{F}}_i$, \hat{u}_j is directly decoded as the frozen bits;
- for $j \in \hat{\mathcal{B}}_i$, if $i = 1$, \hat{u}_j is directly decoded as the pre-shared bits, if $i > 1$, \hat{u}_j is directly decoded as the correspondent bit of $\hat{u}^{\hat{\mathcal{E}}_{i-1}}$ in time $i - 1$;
- for $i \in \hat{\mathcal{D}}_i$,

$$\hat{u}_j = \arg \max_{u \in \{0,1\}} p_{U_j | U_1^{j-1}} (u | \hat{u}_1^{j-1}) \quad (57)$$

C. Performance Analyses

Definition 11 For i -th secure transmission with $i \in \llbracket 1, t \rrbracket$, consider a polar subsets division of index N based on the real EB states s_i , have $(\mathcal{L}_i, \mathcal{F}_i, \mathcal{R}_i, \mathcal{B}_i, \mathcal{D}_i, \mathcal{E}_i)$.

For $i \in t(\vee)$, have

$$(\hat{\mathcal{L}}_i, \hat{\mathcal{F}}_i, \hat{\mathcal{R}}_i, \hat{\mathcal{B}}_i, \hat{\mathcal{D}}_i, \hat{\mathcal{E}}_i) = (\mathcal{L}_i, \mathcal{F}_i, \mathcal{R}_i, \mathcal{B}_i, \mathcal{D}_i, \mathcal{E}_i) \quad (58)$$

For $i \in t(\wedge)$, have

$$(\hat{\mathcal{I}}_i, \hat{\mathcal{F}}_i, \hat{\mathcal{R}}_i, \hat{\mathcal{B}}_i, \hat{\mathcal{D}}_i, \hat{\mathcal{E}}_i) \neq (\mathcal{I}_i, \mathcal{F}_i, \mathcal{R}_i, \mathcal{B}_i, \mathcal{D}_i, \mathcal{E}_i) \quad (59)$$

Then define the following subsets for $i \in t(\wedge)$ cases.

- $\xi_i = (\hat{\mathcal{I}}_i \setminus \hat{\mathcal{E}}_i) \cap \mathcal{I}_i$, the set that remains secure and reliable for message bits;
- $\xi'_i = \hat{\mathcal{I}}_i \cap (\mathcal{I}_i \cup \mathcal{F}_i)$, the set that remains secure for $\hat{\mathcal{I}}_i$;
- $\tilde{\xi}_i = \hat{\mathcal{I}}_i \cap (\mathcal{B}_i \cup \mathcal{R}_i)$, the set that is mistaken as secure for $\hat{\mathcal{I}}_i$;
- $\eta_i = (\hat{\mathcal{I}}_i \cup \hat{\mathcal{R}}_i) \cap (\mathcal{I}_i \cup \mathcal{R}_i)$, the set that remains reliable;
- $\eta'_i = \hat{\mathcal{E}}_i \cap (\mathcal{I}_i \cup \mathcal{R}_i)$, the set that remains reliable for $\hat{\mathcal{E}}_i$;
- $\tilde{\eta}_i = (\hat{\mathcal{I}}_i \cup \hat{\mathcal{R}}_i) \cap (\mathcal{B}_i \cup \mathcal{F}_i)$, the set that is mistaken as reliable;
- $\tilde{\eta}'_i = \hat{\mathcal{E}}_i \cap (\mathcal{B}_i \cup \mathcal{F}_i)$, the set that is mistaken as reliable for $\hat{\mathcal{E}}_i$.

Lemma 1 ([20], [21]) *Considering the polarization of the asymmetric discrete memoryless wiretap channel, for $\beta \in (0, 1/2)$, $\delta_N = 2^{-N^\beta}$, have*

$$\begin{aligned} \lim_{N \rightarrow \infty} \frac{1}{N} |\mathcal{H}_X| &= H(X) \\ \lim_{N \rightarrow \infty} \frac{1}{N} |\mathcal{L}_X| &= 1 - H(X) \\ \lim_{N \rightarrow \infty} \frac{1}{N} |\mathcal{H}_{X|Y}| &= H(X|Y) \\ \lim_{N \rightarrow \infty} \frac{1}{N} |\mathcal{L}_{X|Y}| &= 1 - H(X|Y) \end{aligned} \quad (61)$$

Thus, have

$$\begin{aligned} \lim_{N \rightarrow \infty} \frac{1}{N} |\mathcal{H}_X \cap \mathcal{L}_{X|Y}| &= I(X; Y) \\ \lim_{N \rightarrow \infty} \frac{1}{N} |\mathcal{H}_X \cap (\mathcal{H}_{X|Z})^c| &= I(X; Z) \end{aligned} \quad (63)$$

Proposition 2 (Achievable secrecy rate) *Let $\mathbf{R}_s(t)$ be the secrecy rate of t time secure transmission for our proposed active secure polar coding scheme, when $(\omega + t) \rightarrow \infty$, the upper bound $\mathbf{R}_s(t)$ achieves is greater than the upper bound of C_{us} under the reliability and strong security criterion for GV-WTC.*

Proof:

$$\begin{aligned}
\mathbf{R}_s(t) &= \frac{1}{Nt} \left(\sum_{t(\vee)} |\hat{\mathcal{L}}_i \setminus \hat{\mathcal{E}}_i| + \sum_{t(\wedge)} |\xi_i| \right) \\
&= \frac{1}{Nt} \sum_{t(\vee)} (|\hat{\mathcal{L}}_i| - |\hat{\mathcal{B}}_{\max}|) + \frac{1}{Nt} \sum_{t(\wedge)} |\xi_i| \\
&\leq \frac{1}{Nt} \sum_{t(\vee)} (|\hat{\mathcal{L}}_i| - |\hat{\mathcal{B}}_i|) + \frac{1}{Nt} \sum_{t(\wedge)} |\xi_i| \\
&= \frac{1}{Nt} \sum_{t(\vee)} \left[(|\hat{\mathcal{L}}_i| + |\hat{\mathcal{R}}_i|) - (|\hat{\mathcal{B}}_i| + |\hat{\mathcal{R}}_i|) \right] + \frac{1}{Nt} \sum_{t(\wedge)} |\xi_i| \\
&= \frac{1}{t} \sum_{t(\vee)} \frac{|\mathcal{H}_X^{(i)} \cap \mathcal{L}_{X|Y}^{(i)}| - |\mathcal{H}_X^{(i)} \cap (\mathcal{H}_{X|Z}^{(i)})^c|}{N} + \frac{1}{Nt} \sum_{t(\wedge)} |\xi_i| \\
&\stackrel{(d)}{=} \frac{1}{t} \sum_{t(\vee)} [I(U; Y|\hat{c}_i \vee s_i) - I(U; Z|\hat{c}_i \vee s_i)] + \frac{1}{Nt} \sum_{t(\wedge)} |\xi_i| \\
&= \frac{1}{t} \sum_{t(\vee)} C_s(\hat{c}_i \vee s_i) + \frac{1}{t} \sum_{t(\wedge)} \frac{|\xi_i|}{N} \\
&\leq \frac{1}{t_{\vee}} \sum_{t(\vee)} C_s(\hat{c}_i \vee s_i) + \frac{1}{t} \sum_{t(\wedge)} \frac{|\xi_i|}{N} \\
&= \bar{C}_{s-t(\vee)} + \frac{1}{t} \sum_{t(\wedge)} \frac{|\xi_i|}{N}
\end{aligned} \tag{65}$$

where (d) is due to Lemma 1. With $(\omega + t) \rightarrow \infty$ and $N \rightarrow \infty$, have $t(\wedge) \rightarrow \emptyset$, thus $\mathbf{R}_s(t)$ is upper bounded by $\bar{C}_{s-t(\vee)}$, which is the average secrecy capacity of matched cases that $\bar{C}_{s-t(\vee)} \geq \min C_s(\mathcal{S})$. \blacksquare

Lemma 2 ([4], [22]) *Considering an arbitrary subset \mathcal{A} of index N for DMC W , in case of \mathcal{A} used as the information set and \mathcal{A}^c used as frozen set for polar coding, by applying the successive cancellation decoding, for $\beta \in (0, 1/2)$, $\delta_N = 2^{-N^\beta}$, the block error probability is bounded by*

$$\max_{i \in \mathcal{A}} \frac{1}{2} (1 - \sqrt{1 - Z(W_N^{(i)})^2}) \leq P_e(\mathcal{A}) \leq \sum_{i \in \mathcal{A}} Z(W_N^{(i)}) \tag{66}$$

especially when

$$\mathcal{A} \subseteq \{i \in [1, N] : Z(U_i|U_1^{i-1}) \leq \delta_N\} \tag{67}$$

have

$$\mathbf{P}_e(\mathcal{A}) \leq \sum_{i \in \mathcal{A}} Z(U_i | U_1^{i-1}, Y^N) = O(2^{-N^\beta}) \quad (68)$$

Proposition 3 (Reliability) *Let $\mathbf{P}_e(t)$ be the error probability of t times secure communication based on the proposed active secure polar coding scheme. Then when $(\omega+t) \rightarrow \infty$, the reliability criterion in Definition 6 can be achieved for $\beta \in (0, 1/2)$, $\delta_N = 2^{-N^\beta}$.*

Proof:

$$\begin{aligned} \mathbf{P}_e(t) &= \Pr\{M_1^t \neq \hat{M}_1^t \text{ or } (U^\mathcal{E})_2^t \neq (\hat{U}^\mathcal{E})_2^t\} \\ &\stackrel{(e)}{=} \sum_{i \in t(\vee)} \left[\sum_{j \in \hat{\mathcal{E}}_i} Z(U_j | U_1^j, Y^N) + \sum_{j \in \mathcal{I}_i \cup \hat{\mathcal{R}}_i} Z(U_j | U_1^j, Y^N) \right] \\ &\quad + \sum_{i \in t(\wedge)} \left[\sum_{j \in \eta'_i} Z(U_j | U_1^j, Y^N) + \sum_{j \in \eta_i} Z(U_j | U_1^j, Y^N) \right] \\ &\quad + \sum_{i \in t(\wedge)} \left[\sum_{j \in \tilde{\eta}'_i} Z(U_j | U_1^j, Y^N) + \sum_{j \in \tilde{\eta}_i} Z(U_j | U_1^j, Y^N) \right] \\ &\leq (2t_\vee + 2t_\wedge) O(2^{-N^\beta}) + \sum_{i \in t(\wedge)} \sum_{\tilde{\eta}'_i + \tilde{\eta}_i} Z(U_j | U_1^j, Y^N) \\ &= 2t O(2^{-N^\beta}) + \sum_{i \in t(\wedge)} \sum_{\tilde{\eta}'_i + \tilde{\eta}_i} Z(U_j | U_1^j, Y^N) \end{aligned} \quad (70)$$

where (e) is due to Lemma 2. When $(\omega+t) \rightarrow \infty$, have $t(\wedge) \rightarrow \emptyset$, thus $\mathbf{P}_e(t) \leq 2t O(2^{-N^\beta})$ which satisfies the reliability criterion. \blacksquare

Lemma 3 ([6]) *Considering the multi-block chaining structure and the polar subset division of index N , for $k \in \llbracket 1, t \rrbracket$, let $E_k = U^{\mathcal{E}^k}$, $Z_k = (Z^N)_k$, $I_1^k = I(M_1^k E_k; Z_1^k)$, have*

$$I_1^k \leq I_1^{k-1} + I(M_k E_k; Z_k) \quad (71)$$

Definition 12 *For arbitrary subset \mathcal{A} of index N , define $q_1 < q_2 < \dots < q_{|\mathcal{A}|}$ be the correspondent indices of the elements $U^{\mathcal{A}}$, and*

$$U^{\mathcal{A}} \triangleq U_{q_1}^{q_{|\mathcal{A}|}} = U_{q_1}, U_{q_1}, \dots, U_{q_{|\mathcal{A}|}} \quad (72)$$

Lemma 4 ([9]) *Considering the multi-block chaining structure and the polar subset division of index N , for arbitrary $\mathcal{A} \subseteq \mathcal{H}_{X|Z}$, $i \in \llbracket 1, |\mathcal{A}| \rrbracket$, $q_i \in \mathcal{A}$, $\beta \in (0, 1/2)$, $\delta_N = 2^{-N^\beta}$, have*

$$\begin{aligned} H(U_{q_i} | U_{q_1}^{q_i-1}, Z^N) &\geq H(U_{q_i} | U_1^{q_i-1}, Z^N) \\ &\geq 1 - O(N^2 2^{-N^\beta}) \end{aligned} \quad (74)$$

Proposition 4 (Security) *Let $\mathbf{L}(t)$ be the information leakage of t times secure communication based on the proposed active secure polar coding scheme. Then when $(\omega + t) \rightarrow \infty$, the strong security criterion in Definition 6 can be achieved for $\beta \in (0, 1/2)$, $\delta_N = 2^{-N^\beta}$.*

Proof:

$$\begin{aligned} \mathbf{L}(t) &= I(M_1^t; Z_1^t) \leq I(M_1^t E_t; Z_1^t) \\ &\stackrel{(f)}{\leq} \sum_{k=1}^t I(M_k E_k; Z_k) \\ &= \sum_{t(\vee)} I(M_k E_k; Z_k) + \sum_{t(\wedge)} I(M_k E_k; Z_k) \end{aligned} \quad (76)$$

where (f) is due to Lemma 3. For $k \in t(\vee)$, have

$$\begin{aligned} I(M_k E_k; Z_k) &= I(U^{\hat{\mathcal{I}}_k}; Z^N) \\ &= \sum_{i=1}^{|\hat{\mathcal{I}}_k|} I(U_{q_i}; Z^N | U_{q_1}^{q_i-1}) \\ &\stackrel{(g)}{=} \sum_{i=1}^{|\hat{\mathcal{I}}_k|} I(U_{q_i}; U_{q_1}^{q_i-1}, Z^N) \\ &\stackrel{(h)}{=} \sum_{i=1}^{|\mathcal{I}_k|} I(U_{q_i}; U_{q_1}^{q_i-1}, Z^N) \\ &= \sum_{i=1}^{|\mathcal{I}_k|} [H(U_{q_i}) - H(U_{q_i} | U_{q_1}^{q_i-1}, Z^N)] \\ &\stackrel{(i)}{\leq} O(N^3 2^{-N^\beta}) \end{aligned} \quad (78)$$

where (g) is because U_{q_i} are independent from each other, (h) is because $\hat{\mathcal{I}} = \mathcal{I}$ for matched case, (i) is due to Lemma 4. Thus

$$\sum_{t(\vee)} I(M_k E_k; Z_k) \leq t_{\vee} O(N^3 2^{-N^\beta}) \quad (79)$$

For $k \in t(\wedge)$, have

$$\begin{aligned}
I(M_k E_k; Z_k) &= I(U^{\hat{\mathcal{I}}_k}; Z^N) \\
&= \sum_{i=1}^{|\hat{\mathcal{I}}_k|} I(U_{q_i}; Z^N | U_{q_1}^{q_i-1}) \\
&= \sum_{i=1}^{|\hat{\mathcal{I}}_k|} I(U_{q_i}; U_{q_1}^{q_i-1}, Z^N) \\
&\stackrel{(j)}{=} \sum_{i=1}^{|\xi'_k|} I(U_{q_i}; U_{q_1}^{q_i-1}, Z^N) + \sum_{j=1}^{|\tilde{\xi}_k|} I(U_{q_j}; U_{q_1}^{q_j-1}, Z^N) \\
&\stackrel{(k)}{\leq} O(N^3 2^{-N^\beta}) + \sum_{j=1}^{|\tilde{\xi}_k|} I(U_{q_j}; U_{q_1}^{q_j-1}, Z^N)
\end{aligned} \tag{81}$$

where (j) is due to Definition 11, (k) is due to Lemma 4. Thus

$$\begin{aligned}
\sum_{t(\wedge)} I(M_k E_k; Z_k) &\leq t_{\wedge} O(N^3 2^{-N^\beta}) \\
&\quad + \sum_{t(\wedge)} \sum_{j=1}^{|\tilde{\xi}_k|} I(U_{q_j}; U_{q_1}^{q_j-1}, Z^N)
\end{aligned} \tag{83}$$

therefore

$$\mathbf{L}(t) \leq t O(N^3 2^{-N^\beta}) + \sum_{t(\wedge)} \sum_{j=1}^{|\tilde{\xi}_k|} I(U_{q_j}; U_{q_1}^{q_j-1}, Z^N) \tag{84}$$

when $(\omega + t) \rightarrow \infty$, have $t(\wedge) \rightarrow \emptyset$, thus $\mathbf{L}(t) \leq t O(N^3 2^{-N^\beta})$, so the strong security criterion is achieved. ■

V. CONCLUSION

In this paper, we have proposed a novel solution for A-WTC secure communication, called active secure coding scheme, which combines the method of machine learning to the traditional physical layer secure coding scheme to provide an active defense against the active eavesdropper, especially under the unlimited computational power condition.

To build an universal active coding method, we construct an HMM based abstract detectable A-WTC with the notions of EB state and EB pattern. Based on this abstract model, we apply the machine learning algorithms to construct a EB pattern learning and EB stated decoding schemes, which can effectively estimate the optimal EB state from the legitimate parties' observations.

Therefore physical layer secure coding can actively responding the eavesdropper according to the estimated EB state.

Then we perform the active coding method to the GV-WTC and construct an explicit active secure polar coding scheme. In the scheme, we extends the multi-block chaining structure to adapt the EB states shifting cases for achieve the strong security for t times secure communication.

As proofed, both the active secure coding scheme for abstract A-WTC and active secure polar coding scheme for GV-WTC can achieve the average secrecy capacity under the reliability and strong security criterions.

APPENDIX A

THE BAUM-WELCH ALGORITHM FOR EB PATTERN LEARNING

Considering the HMM model $(\mathcal{S}, \mathcal{O}, \mathbf{A}, \mathbf{B}, \pi)$ introduced in Section III with unknown EB pattern time sequence s_1^t and detected observation time sequence o_1^t . Assume we know the full set of \mathcal{S} and \mathcal{O} . Define $b_i(o_j) = p(o_j|s_i)$ and set random initial conditions to $\lambda = (\mathbf{A}, \mathbf{B}, \pi)$. Then the Baum-Welch algorithm [18] for EB pattern learning is as follow.

- i. Forward procedure: for $i \in \llbracket 1, \alpha \rrbracket$, $k \in \llbracket 1, t \rrbracket$, denote

$$\mu_i(k) = p(o_1^k, S_k = si | \lambda) \quad (85)$$

initialization

$$\mu_i(1) = \pi_i b_i(o_1) \quad (86)$$

recursion

$$\mu_i(k+1) = b_j(o_{k+1}) \sum_{j=1}^{\alpha} \mu_j(k) a_{ji} \quad (87)$$

- ii. Backward procedure: for $i \in \llbracket 1, \alpha \rrbracket$, $k \in \llbracket 1, t \rrbracket$, denote

$$\rho_i(k) = p(o_1^k | S_k = si, \lambda) \quad (88)$$

initialization

$$\rho_i(t) = 1 \quad (89)$$

recursion

$$\rho_i(k) = \sum_{j=1}^{\alpha} \rho_j(k+1) a_{ij} b_j(o_{k+1}) \quad (90)$$

iii. Update: denote $v_i(k) = p(S_k = \mathbf{si} | o_1^k, \lambda)$ and $\phi_{ij}(k) = p(S_k = \mathbf{si}, S_{k+1} = \mathbf{sj} | o_1^k, \lambda)$. Then according to the Bayes theorem, have

$$v_i(k) = \frac{p(S_k = \mathbf{si}, o_1^k | \lambda)}{p(o_1^k | \lambda)} = \frac{\mu_i(k) \rho_i(k)}{\sum_{j=1}^{\alpha} \mu_j(k) \rho_j(k)} \quad (91)$$

$$\begin{aligned} \phi_{ij}(k) &= \frac{p(S_k = \mathbf{si}, S_{k+1} = \mathbf{sj}, o_1^k | \lambda)}{p(o_1^k | \lambda)} \\ &= \frac{\mu_i(k) a_{ij} \rho_j(k+1) b_j(o_{k+1})}{\sum_{i=1}^{\alpha} \sum_{j=1}^{\alpha} \mu_i(k) a_{ij} \rho_j(k+1) b_j(o_{k+1})} \end{aligned} \quad (93)$$

Then the parameter set λ of the HMM can be updated by

$$\pi_i^* = v_i(1) \quad (94)$$

$$a_{ij}^* = \frac{\sum_{k=1}^{t-1} \phi_{ij}(k)}{\sum_{k=1}^{t-1} v_i(k)} \quad (95)$$

$$b_{ij}^* = \frac{\sum_{k+1}^t \mathbb{1}_{o_k = \mathbf{oj}} v_i(k)}{\sum_{k+1}^t v_i(k)} \quad (96)$$

where $i \in \llbracket 1, \alpha \rrbracket$, $j \in \llbracket 1, \gamma \rrbracket$, $k \in \llbracket 1, t \rrbracket$

$$\mathbb{1}_{o_k = \mathbf{oj}} = \begin{cases} 1 & \text{if } o_k = \mathbf{oj} \\ 0 & \text{otherwise} \end{cases} \quad (97)$$

APPENDIX B

THE VITERBI ALGORITHM FOR EB STATE DECODING

Following the notation for HMM in Appendix A, assume we know the full set of \mathcal{S} and \mathcal{O} , know the parameter set λ and have the observation o_1^t .

For $i \in \llbracket 1, \alpha \rrbracket$, $k \in \llbracket 1, t \rrbracket$, denote $\kappa_i(t)$ as the probability of the most likely path \hat{s}_1^k with $\hat{s}_t = \mathbf{si}$ that generates the observation o_1^k , denote $\tau_i(k)$ as the \hat{s}_{k-1} of the most likely path \hat{s}_1^{k-1} with $\hat{s}_k = \mathbf{si}$, have

$$\kappa_i(k) = \max_{s \in \mathcal{S}} p(\hat{s}_1^k, \hat{s}_t = \mathbf{si}, o_1^k, \lambda) \quad (98)$$

Then the Viterbi algorithm [19] for EB state decoding is as follow.

i. Initialization with

$$\begin{aligned} \kappa_i(1) &= \pi_i b_i(o_1) \\ \tau_i(1) &= 0 \end{aligned} \quad (100)$$

ii. Recursion for $i \in \llbracket 1, \alpha \rrbracket$, $k \in \llbracket 2, t \rrbracket$

$$\begin{aligned}\kappa_i(k) &= \max_{i \in \llbracket 1, \alpha \rrbracket} [\kappa_i(k-1)a_{ij}b_j(o_k)] \\ \tau_i(k) &= \arg \max_{i \in \llbracket 1, \alpha \rrbracket} [\kappa_i(k-1)a_{ij}b_j(o_k)]\end{aligned}\tag{102}$$

iii. End for

$$\begin{aligned}p^* &= \max_{i \in \llbracket 1, \alpha \rrbracket} \kappa_i(t) \\ s_t^* &= \arg \max_{i \in \llbracket 1, \alpha \rrbracket} \kappa_i(t)\end{aligned}\tag{104}$$

vi. Path trace, for $k = t-1, t-2, \dots, 1$

$$s_k^* = \tau_{s_{k+1}^*}(k+1)\tag{105}$$

REFERENCES

- [1] P. W. Shor, "Algorithms for quantum computation: discrete logarithms and factoring, *Foundations of Computer Science, 1994 Proceedings. Symposium on IEEE*, pp. 124-134, 2002.
- [2] T. Monz, D. Nigg, E. A. Martinez, M. F. Brandl, P. Schindler, R. Rines, S. X. Wang, I. L. Chuang and R. Blatt, "Realization of a scalable shor algorithm, *Science*, vol. 351, no. 6277, 1068-1070, 2016.
- [3] A. D. Wyner, "The wire-tap channel", *Bell System Tech. J.*, vol. 54, no. 8, pp. 1355-1387, Oct. 1975.
- [4] E. Arikan, "Channel polarization: a method for constructing capacity achieving codes for symmetric binary-input memoryless channels", *IEEE Trans. Inf. Theory*, vol. 55, no. 7, pp. 3051-3073, Jul. 2009.
- [5] H. MahdaviFar, A. Vardy, "Achieving the secrecy capacity of Wiretap channels using Polar codes", *IEEE Trans. Inf. Theory*, vol. 57, no. 10, pp. 6428-6443, Oct. 2011.
- [6] E. Şaşıoğlu, A. Vardy, "A New Polar Coding Scheme for Strong Security on Wiretap Channels", *IEEE Int. Symp. Inf. Theory (ISIT)*, pp. 1117-1121, Jul. 2013.
- [7] S. H. Hassani, R. Urbanke, "Universal polar code", in *IEEE Int. Symp. Inf. Theory (ISIT)*, pp. 1451 - 1455, Jun. 2014.
- [8] Y.-P. Wei, S. Ulukus, "Polar coding for the general wiretap channel", in *Proc. Information Theory Workshop*, pp. 1-5, Apr. 26/May 1 2015.
- [9] T. C. Gulcu, A. Barg, "Achieving secrecy capacity of the wiretap channel and broadcast channel with a confidential component", in *Proc. IEEE Inf. Theory Workshop*, pp. 1-5, Apr. 26/May 1 2015.
- [10] M. Zheng, M. Tao, W. Chen, and C. Ling, "Secure Polar Coding for the Two-Way Wiretap Channel," *ArXiv e-prints*, 2017.[Online]
- [11] L. H. Ozarow and A. D. Wyner, "Wire-tap channel II, AT&T Bell Laboratories technical journal, vol. 63, no. 10, pp. 2135-2157, 1984.
- [12] P. Wang and R. Safavi-Naini, "A model for adversarial wiretap channels, *IEEE Trans. Inf. Theory*, vol. 62, no. 2, pp. 970-983, 2013.
- [13] Z. Goldfeld, P. Cuff and H. H. Permuter, "Arbitrarily varying wiretap channels with type constrained states, *IEEE Trans. Inf. Theory*, vol. 62, no. 12, pp. 7216-7244, 2016.
- [14] R. F. Schaefer, H. Boche and H. V. Poor, "Secure communication under channel uncertainty and adversarial attacks, *Proceedings of the IEEE*, vol. 103, no. 10, pp. 1796-1813, 2015.

- [15] F. Cheng, R. W. Yeung and K. W. Shum, "Imperfect secrecy in wiretap channel II, *IEEE Int. Symp. Inf. Theory (ISIT)*, pp. 71-75, 2012.
- [16] M. Nafea and A. Yener, "A new wiretap channel model and its strong secrecy capacity, *IEEE Int. Symp. Inf. Theory (ISIT)*, pp. 2804-2808, 2016.
- [17] M. Tahmasbi, M. R. Bloch and A. Yener, "Learning adversary's actions for secret communication, *IEEE Int. Symp. Inf. Theory (ISIT)*, pp. 2708-2712, 2017.
- [18] Welch and R. Lloyd, "Hidden Markov Models and the Baum-Welch algorithm, *IEEE Information Theory Society Newsletter*, vol. 53, no. 2, pp. 194-211, 2003.
- [19] B. L. Van, S. Garcia-Salicetti and B. Dorizzi, "On using the viterbi path along with HMM likelihood information for online signature verification, *IEEE Transactions on Systems Man & Cybernetics Part B*, vol. 37, no. 5, pp. 1237-1247, 2007.
- [20] E. Arikan, "Source polarization, *IEEE Int. Symp. Inf. Theory (ISIT)*, pp. 899-903, 2010.
- [21] J. Honda and H. Yamamoto, "Polar coding without alphabet extension for asymmetric models, *IEEE Trans. Inf. Theory*, vol. 59, no. 12, pp. 7829-7838, 2013.
- [22] S. B. Korada, "Polar Codes for Channel and Source Coding", *Ph.D. Thesis, Ecole Polytechnique Federale de Lausanne, Lausanne, Switzerland*, 2009.
- [23] F. R. Scott, "Understanding the Bias-Variance Tradeoff", *An essay by Scott Fortmann-Roe*, 2012, <http://scott.fortmann-roe.com/>.
- [24] T. Hastie, R. Tibshirani and J. Friedman, "The elements of statistical learning", *Journal of the Royal Statistical Society*, vol. 167, no. 1, pp. 267-268, 2001.