

Erasure Correction for Noisy Radio Networks

Keren Censor-Hillel*, Bernhard Haeupler†, D. Ellis Hershkowitz†, Goran Zuzic†

September 2, 2022

Abstract

The radio network model is a well-studied abstraction for modeling wireless multi-hop networks. However, radio networks make the strong assumption that messages are delivered deterministically. The recently introduced noisy radio network model relaxes this assumption by dropping messages independently at random.

In this work we quantify the relative computational power of noisy radio networks and classic radio networks. In particular, given a protocol for a fixed radio network we show how to reliably simulate this protocol if noise is introduced with a multiplicative cost of $\text{poly}(\log \Delta, \log \log n)$ rounds. For this result we make the simplifying assumption that the simulated protocol is *static*. Moreover, we demonstrate that, even if the simulated protocol is not static, it can be simulated with a multiplicative $O(\Delta \log \Delta)$ cost in the number of rounds. Hence, our results show that protocols on constant-degree networks can be made robust to random noise with constant multiplicative overhead. Lastly, we argue that simulations with a multiplicative overhead of $o(\log \Delta)$ are unlikely to exist by proving that an $\Omega(\log \Delta)$ multiplicative round overhead is necessary under certain natural assumptions.

*Supported in part by the Israel Science Foundation (grant 1696/14) and the Binational Science Foundation (grant 2015803).

†Supported in part by NSF grants CCF-1527110, CCF-1618280 and NSF CAREER award CCF-1750808.

1 Introduction

The study of distributed graph algorithms provides precise mathematical models to understand how to accomplish distributed tasks with minimal communication. A classic example of such a model is the radio network model of Chlamtac and Kutten [12]. Radio networks use synchronous rounds of communication and were designed to model the collisions that occur in multi-hop, wireless networks. However, radio networks make the strong assumption that, provided no collisions occur, messages are guaranteed to be delivered.

This assumption is overly optimistic for real environments in which noise may impede communication, and so we previously introduced the noisy radio network model where messages are randomly dropped with a constant probability [9]. We demonstrated that the runtime of existing state-of-the-art broadcast protocols deteriorates significantly in the face of random noise. Furthermore, we showed how to design efficient broadcasting protocols that are robust to noise.

However, it has remained unclear how much more computationally powerful the radio network model is compared to the noisy radio network model. In particular, it was not known how efficiently an arbitrary protocol from a radio network can be *simulated* by a protocol in a noisy radio network. A simulation with little overhead would demonstrate that radio networks and noisy radio networks are of similar computational power. However, if simulation were necessarily expensive then radio networks would be capable of completing more communication-intensive tasks than their noisy counterparts.

A trivial observation regarding the relative power of these two models is that any polynomial-length radio network protocol can be simulated at a multiplicative cost of $O(\log n)$ rounds. In particular, we can simulate any protocol from the non-noisy setting by repeating every round $O(\log n)$ times. A Chernoff and union bound show that every message sent by the original protocol is successfully sent with high probability. However, $O(\log n)$ is a significant price to pay for noise-robustness for many radio network protocols. For example, the optimal known-topology message broadcast protocol of Gaşieniec et al. [22] uses only $O(D + \log^2 n)$ rounds, while the topology-oblivious Decay protocol of Bar-Yehuda et al. [6] takes $O(D \log n + \log^2 n)$. Moreover, a dependence on a global property of the network—the number of nodes in the graph—is surely overkill to correct for a local issue—faults.

1.1 Our Results

In this work we demonstrate that radio network protocols can be simulated by noisy radio networks with a multiplicative dependence on Δ , the maximum degree of the network. Thus, we demonstrate that, for low-degree networks, noisy radio networks are essentially of the same computational power as radio networks. Moreover, we demonstrate that this dependence is essentially tight in two natural settings.

We give our results in three increasingly difficult settings which we sketch here, highlighting our insights and the technical challenges we overcome in each setting. In all of our simulations nodes store some notion of the round up to which they have successfully simulated and always help their neighbors that have made the least progress. In particular, nodes always simulate the round of their neighbor that has successfully simulated the fewest rounds. We also sketch our lower bound results here.

Local Progress Detection As a warmup we begin by providing a simulation with $O(\log \Delta)$ multiplicative round overhead in the setting where nodes have access to “*local progress detection*”.

Roughly, local progress detection enables nodes to know how many rounds of the original protocol each of their neighbors have successfully simulated. Our crucial insight in this setting is that allowing nearby nodes to simulate the same round of the original protocol while flexibly allowing distant nodes to simulate different rounds enables a multiplicative round overhead with a dependence on Δ . (Section 4.1)

Static Protocols Next we provide simulations for *static* protocols. Roughly, static protocols are protocols in which nodes know in which rounds they receive messages. In this setting, our simulations achieve a multiplicative $O(\log^3 \Delta \cdot \log \log n \cdot \log \log \log n) = \text{poly}(\log \Delta, \log \log n)$ round overhead *without local progress detection*. As we argue in Section 4.2, a number of well-known protocols (e.g. the optimal broadcast algorithm of Gąsieniec et al. [22]) are static. What makes this setting particularly difficult is that nodes have no way of knowing what sort of progress their neighbors have made. Simulating static protocols therefore isolates the challenge of efficiently sharing information locally in a noisy radio network. We overcome this challenge by using a distributed binary search which carefully silences nodes that search over divergent ranges. Moreover, we keep the range over which the binary search must search tractable by throttling nodes that make progress too quickly. (Section 4.2)

General Protocols We also give simulations for arbitrary radio network protocols with a multiplicative $O(\Delta \log \Delta)$ overhead. The challenge of the general setting is the asymmetric nature of the radio network model: a node v can communicate to its Δ neighbors in 1 round, but it takes Δ rounds until all of v 's neighbors can communicate with v . It is difficult, then, for a node that broadcasted to know with certainty that all of its neighbors received its message. For this reason, our simulation involves nodes exchanging messages with all neighbors in every round to preclude the possibility of a dropped message going unnoticed. We note that the $O(\Delta)$ difference between this result and our $O(\log \Delta)$ with local progress detection suggests that the primary challenge in simulation is not in recovering information lost to noise but rather in exchanging information regarding how much progress nodes have made. (Section 5)

Lower Bounds Lastly, we show that two natural classes of simulations necessarily use $\Omega(\log \Delta)$ multiplicatively many more rounds than the protocols which they simulate. In particular, a simulation that either (1) does not use network coding, or (2) sends information in the same way as the original protocol requires $\Omega(\log \Delta)$ multiplicatively many more rounds than the original protocol. We also give a protocol which we conjecture unconditionally requires $\Omega(\log \Delta)$ multiplicatively many more rounds to be simulated by any protocol in the noisy setting. (Section 6)

2 Related work

2.1 Robust Communication

Several models have been studied to understand robust communication. El-Gamal. [14] introduced the noisy broadcast model, which also assumes random errors, and focuses on studying the computation of functions of the inputs of nodes [16; 33; 23; 31]. The model of El-Gamal. [14] differs from our model in that it assumes a complete communication network and single-bit transmissions. Rajagopalan and Schulman [35] introduced a similar model which again assumes single-bit transmissions and also does not have collisions as our model does.

Another model which captures uncertainty is the *dual graph* model [29; 8; 28; 18; 19], in which an adversary chooses a set of unreliable edges in each round.

There has also been extensive work on two-party interactive communication in the presence of noise [36; 24; 17]. In this setting, Alice and Bob have some conversation in mind they would like to execute over a noisy channel; by adding redundancy they hope to hold a slightly longer conversation from which they can recover the original conversation outcome even when a fraction of the coded conversation is corrupted. Multi-party generalizations of this problem have also been studied [7]. Our model can be seen as a radio network analogue of these interactive communication models in which erasures occur rather than corruptions.

Lastly, work on MAC layers has sought to provide abstractions for algorithms that hide low-level uncertainty in wireless communication [20; 27]. Radio networks differ from MAC layers as in radio networks it is not required that a sender receive an acknowledgement from a receiver.

2.2 Radio Networks

Since its introduction by Chlamtac and Kutten [12], the classic radio network model has attracted wide attention from researchers. The survey of [34] is an excellent overview of this research area.

Here we focus the radio network literature that relates to our work. Much of previous work for the noisy radio network model focused on broadcast. For the classic model, Bar-Yehuda et al. [6] gave a single-message broadcast algorithm for a known topology, which completes in $O(D \log n + \log^2 n)$ rounds, where D is the diameter of the network. In Censor-Hillel et al. [9] we showed that this protocol is robust to noise, completing in $O(\frac{\log n}{1-p}(D + \log n + \log \frac{1}{\delta}))$ rounds, with a probability of failure of at most δ . In the classic model, single-message broadcast was then improved by Gašieniec et al. [22] and Kowalski and Pelc [26], who showed that in the case of a known topology, $O(D + \log^2 n)$ rounds suffice. In Censor-Hillel et al. [9] we showed that this protocol is *not* robust to noise, requiring in expectation $\Theta(\frac{p}{1-p}D \log n + \frac{1}{1-p}D)$ rounds, for broadcasting a message along a path of length D . We showed an alternative protocol, completing in $O(D + \log n \log \log n (\log n + \log \frac{1}{\delta}))$ rounds, with a probability of failure of at most δ . For an unknown topology in the classic model, Czumaj and Rytter [13] give a protocol completing in $O(D \log(n/D) + \log^2 n)$ rounds, which is optimal, due to the $\Omega(\log^2 n)$ and $\Omega(D \log(n/D))$ lower bounds of Alon et al. [2] and Kushilevitz and Mansour [30], respectively. Ghaffari et al. [21] give a $O(D + \text{poly} \log n)$ -round protocol that uses *collision detection*.

2.3 Simulations

Lastly, simulations of models of distributed computation by other models of distributed computation is a foundational aspect in distributing computing, dating back to the 80's–90's with many simulations of various shared memory primitives, faults, and more (see a wide variety in, e.g., Attiya and Welch [3]). It is also a focus for message-passing models with different features, being the motivation for synchronizers [4; 5], and additional simulations [10; 11].

3 Model and Assumptions

In this section we formally define the classic radio network model, the noisy radio network model and discuss various assumptions we make throughout the paper.

Radio Networks A multi-hop radio network, as introduced in Chlamtac and Kutten [12], consists of an undirected graph $G = (V, E)$ with $n := |V|$ nodes. Communication occurs in synchronous rounds: in each round, each node either broadcasts a single message containing $\Theta(\log n)$

bits to its neighbors or listens. A node receives a message in a round if and only if it is listening and exactly one of its neighbors is transmitting a message. If two or more neighbors of node v transmit in a single round, their transmissions are said to *collide* at v and v does not receive anything. We assume no collision detection, meaning a node cannot differentiate between when none of its neighbors transmit a message and when two or more of its neighbors transmit a message. Nodes are also typically assumed to have unbounded computation, though all of the protocols in our paper use polynomial computation.

We use the following notational conventions throughout this paper when referring to radio networks. Let $\text{dist}(v, w)$ be the hop-distance between u and v in G , let $\Gamma(v) = \{w \in V : \text{dist}(v, w) \leq 1\}$ denote the 1-hop neighborhood of v , and let $\Gamma^{(k)}(v) = \{w \in V : \text{dist}(v, w) \leq k\}$ denote the k -hop neighborhood of v .

Noisy Radio Networks A multi-hop noisy radio network, as introduced in Censor-Hillel et al. [9], is a radio network with random erasures. In particular, it is a radio network where node v receives a message in a round if and only if it is listening, exactly one of its neighbors is broadcasting and a *receiver fault* does not occur at v . Receiver faults occur at each node and in each round independently with constant probability $p \in (0, 1)$. We assume that in a given round a node cannot differentiate between a message being dropped because of a fault, i.e., a collision, and all of its neighbors remaining silent.

We consider this model because independent receiver faults model transient environmental interference such as the capture effect [32].¹ Moreover, we consider an *erasure* model—entire messages are dropped—rather than a corruption model—messages are corrupted at the bit level—because, in practice, wireless communication typically incorporates error correction and checksums that can guard against bit corruptions [15]. Our model can also be seen as modeling those cases when this error correction fails and the message cannot be reconstructed and is therefore effectively dropped.

Protocols A protocol governs the broadcast and listening behavior of nodes in a network. In particular, a protocol tells each node in each round to listen or what message to broadcast based on the node’s history. This history includes the messages the node received, when it received them and its initial private input. We assume that this private input includes the number of nodes, n , the maximum degree, Δ , the receiver fault probability, p , a private random string, and any other data nodes have as input in a protocol. Formally, a **history** for node v is an $H \in \mathcal{H}$ where \mathcal{H} is all valid histories. $\mathcal{H} = \{(i, R) : i \in \mathcal{I}, R \subseteq M \times \mathbb{N}\}$ where \mathcal{I} is all valid private inputs, R gives what messages v has received in each round and $M = \{0, 1\}^{O(\log n)}$ is all $O(\log n)$ bit messages a node could receive in a single round. Formally, a **protocol** P of length $|P| := T$ is a function $P : V \times [T] \times \mathcal{H} \rightarrow \{\text{listen}\} \cup M$ where $P(v, t, H) = \text{listen}$ indicates that v listens in round t and $P(v, t, H) = m \in M$ indicates that v broadcasts message $m \in M$ in round t . In this paper we assume that T is at most $\text{poly}(n)$.

Simulating a Protocol in the Noisy Setting We say that protocol P' successfully **simulates** P if, after executing P' in the noisy setting, every node in the network can reconstruct the messages it would receive if P were run in the faultless setting. In particular, for any set of private input $I \in \mathcal{I}^{|V|}$ —letting $H(v, I)$ be v ’s history after running P with private inputs I —it must hold that after running P' with private inputs I , every v can compute $H(v, I)$. Note that nodes running P' can send messages not sent by P or send messages in a different order than they do in P . We call P the **original protocol** and P' the **simulation protocol**. We measure the efficacy of P'

¹In contrast, a sender faults model in which an entire broadcast by a node is dropped might model hardware failures where independence of faults would be a poor modeling choice.

as the limiting ratio of $\frac{|P'|}{|P|}$ when T is sufficiently large and n goes to infinity, which we call the **multiplicative overhead** of a simulation.

4 Efficient Simulators for Noisy Radio Networks

We now provide our simulation results. We provide simulations in three settings of increasing difficulty. Throughout our results, we use the notion of a **virtual round** of node v , t_v , which measures how many rounds of v has successfully simulated. All three simulations roughly work by having nodes first exchange their virtual rounds with their neighbors and then having nodes simulate the virtual round of their neighbor with the smallest virtual round. Our simulations differ in how each defines a virtual round and how each exchanges information regarding nodes' virtual rounds.

As a warmup, we consider the setting where nodes have access to “local progress detection”. Local progress detection gives nodes oracle access to the virtual rounds of their neighbors. We show the following theorem.

Theorem 1. *Let P be a general protocol of length T for the faultless radio network model. The described protocol P' is of length $O(T \log \Delta + \log n + k)$ and successfully simulates P in the noisy radio setting using local progress detection with probability at least $1 - \exp(-k)$, for any $k \geq 0$.*

We next show how to efficiently spread virtual round information without using progress detection. In particular, we show the following theorem for protocols that are *static*.²

Theorem 2. *Let P be a static protocol of length T for the faultless radio network model. The simulation routine MAINSTATIC simulates P in the noisy radio setting with high probability. The simulation takes $O((T + \log n) \log^3 \Delta \log \log n \log \log n)$ rounds.*

The crucial property of static protocols that we leverage in our proof of this result is that nodes in a static protocol can efficiently learn their virtual round.

Lastly, we describe how to simulate *any* protocol with a $O(\Delta \log \Delta)$ multiplicative overhead.

Theorem 3. *Let P be a general protocol of length T for the faultless radio network model. The simulation routine MAINGENERAL simulates P in the noisy radio setting with high probability. The simulation takes $O((T + \log n) \Delta \log \Delta)$ rounds.*

4.1 Simulation with Local Progress Detection

We begin by giving our simulation with $O(\log \Delta)$ multiplicative overhead in the setting where nodes have access to **local progress detection**. Though, the assumption of local progress detection is strong, it highlights one of the main proof techniques we make use of when we provide simulations of static protocols, namely the “blaming chain”. Our main theorem of the section is as follows.

Theorem 1. *Let P be a general protocol of length T for the faultless radio network model. The described protocol P' is of length $O(T \log \Delta + \log n + k)$ and successfully simulates P in the noisy radio setting using local progress detection with probability at least $1 - \exp(-k)$, for any $k \geq 0$.*

²When we write that an event occurs **with high probability (w.h.p.)**, we mean that it occurs with probability $1 - \frac{1}{n^c}$, and that the constant $c = \Theta(1)$ can be made arbitrarily large by changing the constants in the routines.

The intuition behind P' is simple: run P but use local progress detection to force nearby nodes to stay locally synchronized. That is, nearby nodes are forced to make a similar amount of progress but far apart nodes are allowed to deviate in terms of the amount of progress they make.

To rigorously define local progress detection, we introduce our notion of how much simulation progress nodes have made, the **virtual round**. We say that a node v successfully completed round t if it has succeeded in taking the action in P that it takes in t : v successfully broadcasts its message m of round t if every node in $\Gamma(v)$ either has received m or had a collision in the original protocol P at round t ; v successfully completes its listening action of round t if v receives the message it receives in round t of P or a collision occurs at v in round t of P . We formally define the virtual round and local progress detection.

Definition 1 (Virtual Round). *The virtual round of node $v \in V$ in a given round of simulation P' is the smallest $t_v \in \mathbb{Z}_{\geq 1}$ such that v has not successfully completed round t_v of P .*

Definition 2 (Local Progress Detection). *In the noisy radio network model with local progress detection every node v knows the virtual round of every node $w \in \Gamma(v)$ in every simulation round.*

Having defined local progress detection, we are now equipped to describe our simulator. **The protocol P'** : Each node v repeatedly does the following in each round of P' . Let u be the node in $\Gamma(v)$ with minimal t_u . v takes the action that it takes in round t_u of P . That is, v tries to “help” u by simulating its virtual round.

We now prove the main theorem of this section.

Proof of Theorem 1. Let $v \in V$ and note that the virtual round t_v never decreases. Hence for $x \in \mathbb{Z}_{\geq 1}$ we can define $D_{v,x}$ as the earliest round in P' when $t_v \geq x$. Notice that $D_{v,T}$ just is the number of rounds that v takes to simulate all rounds of the original protocol P . Thus, it will suffice for us to argue that $D_{v,T}$ is not too large for every v . We begin by finding a recurrence relation on $D_{v,x}$ saying that v will advance soon after its 2-hop neighborhood $\Gamma^{(2)}(v)$ has virtual round at least x .

Consider when $t_v = x - 1$. If the action of v at round $x - 1$ in P is to broadcast, then once v 's virtual round is minimal in $\Gamma^{(2)}(v)$, all of its neighbors will simulate its round. This takes $\max_{w \in \Gamma^{(2)}(v)} D_{w,x-1}$ rounds. Once all nodes in $\Gamma^{(2)}(v)$ have virtual round at least $x - 1$, every such node in $\Gamma(v)$ is simulating round $x - 1$. By definition of P' , v then broadcasts until all of its neighbors that are not incident to a collision in round $x - 1$ of P receive v 's message without a fault occurring. Any neighbor of v that is sent a message without collision in round $x - 1$ in P will now take $\mathcal{G}(p)$ rounds, a geometric random variable with constant expectation. Therefore, the number of rounds until v has sent all its relevant neighbors its message from round $x - 1$ of P is at most $Y_{v,x} := \max\{\mathcal{G}_1(p), \mathcal{G}_2(p), \dots, \mathcal{G}_{|\Gamma(v)|}(p)\}$, where \mathcal{G}_i are IID geometric random variables with constant expectation. Finally, we conclude that $D_{v,x} = \max_{w \in \Gamma^{(2)}(v)} (D_{w,x-1}) + Y_{v,x}$, again, where $Y_{v,x}$ is the maximum of at most Δ many geometric random variables with constant expectation.

If the action of v at round $x - 1$ of P is to receive a message without collision then, after every node in $\Gamma^{(2)}(v)$ has virtual round at least $x - 1$, the neighbor of v that sends v a message without collision in round $x - 1$ of P will repeatedly send this message to v until v receives it without a receiver fault. It takes $\max_{w \in \Gamma^{(2)}(v)} D_{w,x-1}$ rounds of simulation for v to have the smallest virtual round in its neighborhood and it takes $\mathcal{G}(p)$ rounds of simulation for v 's neighbor to send it a message. Thus, in this case we have $D_{v,x} = \max_{w \in \Gamma^{(2)}(v)} (D_{w,x-1}) + \mathcal{G}(p)$.

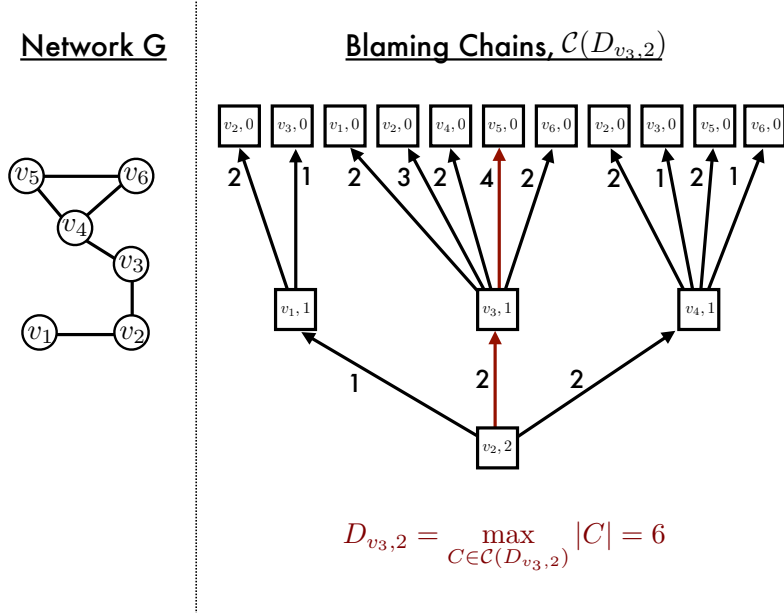

Figure 1: Illustration of blaming chains for $D_{v_3,2}$, namely $\mathcal{C}(D_{v_3,2})$ for a particular network G . A $C \in \mathcal{C}(D_{v_3,2})$ is given by a path away from $v_2, 2$. Blaming chain that gives the value of $D_{v_3,2}$: red. Edge pointing to v_i, x labeled by the value of $Y_{v_i, x}$.

Since in the case when v is broadcasting $D_{v,x}$ is strictly larger than the case in which v is listening, we have $D_{v,x} \leq \left(\max_{w \in \Gamma^{(2)}(v)} D_{w,x-1} \right) + Y_{v,x}$ where $Y_{v,x}$ is the maximum of at most Δ many geometric random variables.

We now prove a tail bound for $D_{v,x}$ by union bounding over all “blaming chains.” A blaming chain for $D_{v,x}$ is a sequence of nodes paired with simulated rounds that could explain why $D_{v,x}$ is as large as it is. In particular, a blaming chain C for $D_{v,x}$ is a sequence of (node, round) tuples $(v_x, x), (v_{x-1}, x-1), \dots, (v_1, 1)$ where $v_i \in \Gamma^{(2)}(v_{i-1})$ and $v_x = v$. We let $\mathcal{C}(D_{v,x})$ stand for all such blaming chains of $D_{v,x}$. We say $|C| := \sum_{(v_i, i) \in C} Y_{v_i, i}$ is the length of blaming chain C . Note that $|\mathcal{C}(D_{v,x})|$ is at most $(\Delta^2)^{x-1}$. Also notice that $D_{v,x}$ just is the length of the longest blaming chain in $\mathcal{C}(D_{v,x})$. See Figure 1. Thus, we have that

$$\begin{aligned}
 D_{v,x} &= \max_{w \in \Gamma^{(2)}(v)} D_{w,x-1} + Y_{v,x} \\
 &= \max_{C \in \mathcal{C}(D_{v,x})} \sum_{(v_i, i) \in C} Y_{v_i, i} \\
 &= \max_{C \in \mathcal{C}(D_{v,x})} |C|
 \end{aligned}$$

As such, to show an upper bound on $D_{v,x}$ it suffices to show that no blaming chain is too long. Notice that the length of a blaming chain in $\mathcal{C}(D_{v,x})$ just is the sum of x random variables each of which is the max of at most Δ geometric random variables with constant expectation. In Lemma 10 of Appendix A we prove a Chernoff-style tail bound for such sums, showing that for any given $C \in \mathcal{C}(D_{v,x})$ we have that $\Pr[|C| \geq c(x \log \Delta + k)] \leq \exp(-k)$ for some constant $c > 0$. Letting

$x = T$ and taking a union bound over all $C \in \mathcal{C}(D_{v,T})$ tells us that for a fixed v we have $\Pr[\exists C \in \mathcal{C}(D_{v,T}) \text{ s.t. } |C| \geq c(T \log \Delta + k)] \leq |\mathcal{C}(D_{v,T})| \cdot \exp(-k) \leq (\Delta^2)^{T-1} \cdot \exp(-k)$. Thus with probability at most $(\Delta^2)^{T-1} \cdot \exp(-k)$ a chain in $\mathcal{C}(D_{v,x})$ is of length more than $c(T \log \Delta + k)$ and so $D_{v,T}$ is of length more than $c(T \log \Delta + k)$ with probability at most $(\Delta^2)^{T-1} \cdot \exp(-k)$.

Taking a union bound over every vertex we have that there exists a vertex v such that $D_{v,T}$ is more than $c(T \log \Delta + k)$ with probability at most $n(\Delta^2)^{T-1} \cdot \exp(-k)$. Setting $k \leftarrow \ln n + (2T - 2) \ln \Delta + k'$ we have that there exists a vertex v such that $D_{v,x}$ is more than $O(T \log \Delta + \log n)$ is at most $\exp(k')$. Thus, we have that every vertex with probability at least $1 - \exp(k')$ has completed the protocol after $O(T \log \Delta + \log n)$ rounds of P' .

□

4.2 Simulation for Static Protocols

We now give our simulation results for static protocols with $\text{poly}(\log \Delta, \log \log n)$ multiplicative round overhead. Formally a static protocol is as follows.

Definition 3 (Static Protocol). *A static protocol P is a protocol in which every node can determine if it receives a message in each round of P regardless of the private inputs of the nodes. Formally, each node v is given a list, M_v , of the rounds in which it receives a message without collision in P .*

We let $M_v.\text{GETNEXTROUND}$ return the smallest round in M_v such that for every $r \in M_v$ such that $r < M_v.\text{GETNEXTROUND}$, v has received the message it receives in round r of P . Notice that, since in a static protocol nodes know in which rounds they receive messages in P , nodes in a simulation can locally compute $M_v.\text{GETNEXTROUND}$.

We focus on static protocols to understand how delays propagate in noisy radio networks and how to efficiently exchange information in noisy radio networks. This focus allows us to avoid some of the messier challenges of simulations in noisy radio networks (see Section 7 for further discussion).

However, we also note that a number of well-known protocols are static. For instance, assuming nodes know the network topology and use public randomness, the optimal broadcast algorithm of Gąsieniec et al. [22] is static. In particular, under these assumptions nodes can compute the broadcast schedule of their neighbors for this protocol. The same is true of the Decay protocol of Bar-Yehuda et al. [6]. Since broadcast is the most studied problem in radio networks, the fact that the state-of-the-art broadcast algorithm is static gives strong evidence that studying static protocols is worthwhile. Moreover, though requiring that nodes know the network topology and use public randomness may seem restrictive, in the context of simulations this assumption is actually quite weak: we can dispense with both assumptions by simply running any primitive that informs nodes of the network topology or shares randomness before our simulation is run at a one-time additive round overhead. Any primitive to learn the network topology or share randomness from the classic radio network setting coupled with the $O(\log n)$ trivial simulation as described in Section 1 suffices here. This overhead is negligible if the simulated protocol is sufficiently long or we run many simulations on our network. Lastly, we note that it is often the case that nodes can even *efficiently* compute the broadcast schedule of their neighbors—see Haeupler and Wajc [25]—and so this one-time cost is often quite small. Broadly speaking, then, any protocol in which knowing the topology and sharing randomness allows nodes to compute their neighbors' broadcast schedule is static.

We now state the main theorem of this section and proceed to describe how we prove it.

Theorem 2. *Let P be a static protocol of length T for the faultless radio network model. The simulation routine MAINSTATIC simulates P in the noisy radio setting with high probability. The simulation takes $O((T + \log n) \log^3 \Delta \log \log n \log \log \log n)$ rounds.*

To prove our theorem we build upon the idea of the preceding section of using virtual rounds to locally synchronize nodes. However, in the current setting it is difficult for nodes to confirm when their broadcasts have succeeded, and so we must relax our definition of virtual rounds. In particular, for the remainder of this section we let the **virtual round** of each node be the minimum between the largest $t_v \in \mathbb{Z}_{\geq 1}$ such that v receives a message without collision in t_v and v has successfully received all messages it receives up to round $t_v - 1$ in P in our simulation and a throttling variable L . That is, the virtual round of v is $\min(M_v.\text{GETNEXTROUND}, L)$. An important property of virtual rounds in this setting is that given L a node can always compute its virtual round.

We use a throttling variable, L , for the following reason. Since we no longer assume nodes have access to local progress detection we must provide a means by which nodes can learn the virtual round of their neighbor. Each node v learns the virtual round of its most delayed neighbor, $\min_{w \in \Gamma(v)} t_w$, via a distributed binary search coupled with a classic Decay algorithm [6]. An important technical challenge we overcome is how we keep the smallest and the largest virtual rounds in the network within a small additive value Q . If nodes were allowed to arbitrarily deviate in terms of simulation progress, our distributed binary search would have to search over a prohibitively large range. For instance, it is easy to see that given a matching between $n/2$ senders and $n/2$ receivers, after T rounds of the senders broadcasting, the virtual rounds of the receivers would deviate by an additive $\Theta(\sqrt{T})$ with high probability. As such, we maintain $Q = O(\log n)$ by slowing down nodes that advance too quickly with our throttling variable L .

We now present the MAINSTATIC simulation routine that simulates P in the noisy setting (Algorithm 1). Its main subroutine, LEARNDELAYS (Algorithm 2), informs each node of the virtual round of its most delayed neighbor. LEARNDELAYS uses helper subroutines (i) DISTTOACTIVE (Algorithm 3) which, given a set of “active” nodes, checks for each v if there is a node within distance 2 of v that is “active”, and (ii) BROADCAST (Algorithm 4) which spreads a message to all neighbors of a node. We give each routine in pseudocode along with the lemma which gives its properties. Throughout our pseudocode we let $P(v, t)$ return the action taken by node v in round t of P . We end this section with the proofs of our lemmas and theorem.

Algorithm 1 MAINSTATIC for node v

```

 $t_v \leftarrow 1$ 
for  $L = 1, 2, \dots, T + O(\log n)$  do                                ▷ “Outermost iteration”
  for repeat  $O(\log \Delta)$  times do                                    ▷ “Innermost iteration”
     $m_v \leftarrow \text{LEARNDELAYS}$ 
    do action  $P(v, m_v)$ 
    if  $m_v = M_v.\text{GETNEXTROUND}$  and  $v$  received a message then
       $t_v \leftarrow \min(L, M_v.\text{GETNEXTROUND})$                                 ▷ Throttle  $v$ 

```

We say that a node v is **most delayed** in its 2-hop neighborhood when $t_v \leq \min_{w \in \Gamma^{(2)}(v)} t_w$.

Lemma 1. *Assume that $L - O(\log n) \leq t_v < L$ for all $v \in V$ and let v be a most delayed node in its 2-hop neighborhood. After an innermost iteration of MAINSTATIC, t_v will increase by one with at least constant probability. Moreover, the running time of each innermost iteration is $O(\log^2 \Delta \log \log n \log \log \log n)$ rounds.*

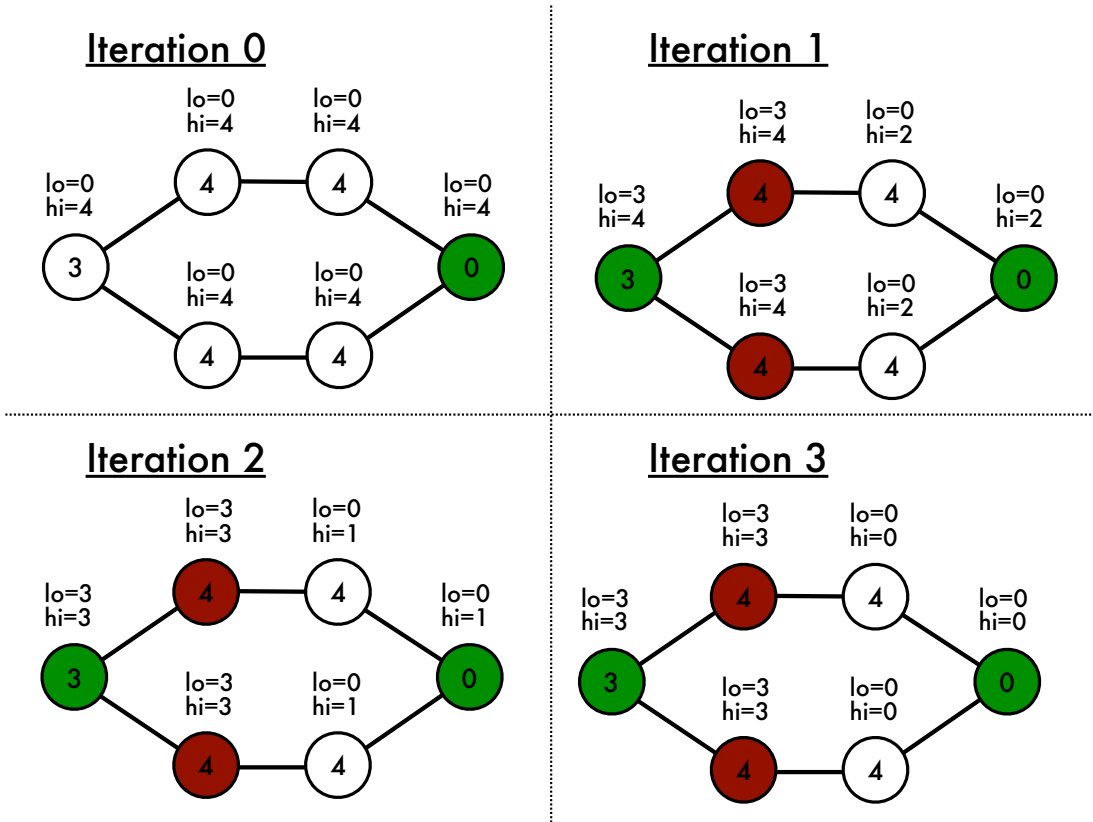

Figure 2: Illustration of `LEARNDELAYS` assuming `DISTTOACTIVE` always successful. Nodes are labeled with their rescaled delays (i.e. v labeled with $t_v - L + O(\log n)$). Silent nodes: red. Active nodes: green. Notice that the far left and far right nodes are minimal in their two-hop neighborhoods so their neighbors learn their delays. Also notice that after iteration 0 neighbors of the node labeled with 0 are never again active since their delay exceeds their value of hi even though these nodes are not marked silent; we use such behavior in the proof of Lemma 2.

We now give our helper routine, `LEARNDELAYS`, which informs nodes of their most delayed neighbors using a distributed binary search. The main challenge of performing a binary search in such a setting is that nodes may deviate in terms of the ranges over which they are searching. This can cause nodes to interfere with the binary of their neighbors. The key idea we use to overcome this issue is to carefully mark nodes “silent” if they might interfere with another node’s binary search. See Figure 2 for an illustration of `LEARNDELAYS`.

Lemma 2. *Assume that $L - O(\log n) \leq t_v \leq L$ for all $v \in V$ and let v be a most delayed node in its 2-hop neighborhood. After `LEARNDELAYS` terminates, each 1-hop neighbor w of v will have $m_w = t_v$ with at least constant probability, i.e., every w will try to help v advance. The running time of `LEARNDELAYS` is $O(\log^2 \Delta \log \log n \log \log \log n)$ rounds.*

We now give `DISTTOACTIVE`, the main helper routine for our distributed binary search routine.

Algorithm 2 LEARNDELAYS for node v

Input: L, t_v $lo \leftarrow L - O(\log n); hi \leftarrow L$ **while** $lo \neq hi$ **do** ▷ repeats $O(\log \log n)$ rounds v is marked as "active" iff $t_v \leq \lfloor \frac{lo+hi}{2} \rfloor$ and v is not marked "silent"dist \leftarrow DISTTOACTIVE**if** dist is "=2" **then** mark v as "silent" until the end of LEARNDELAYS**if** dist is "=0" or "=1" **then** $hi \leftarrow \lfloor \frac{lo+hi}{2} \rfloor$ **else** $lo \leftarrow \lfloor \frac{lo+hi}{2} \rfloor + 1$ **return** lo

Algorithm 3 DISTTOACTIVE for node v

Input: is v active?**Output:** "=0", "=1", "=2", or ">2" as the smallest distance to an active node**if** v is active **then** BROADCAST an arbitrary message X **else** stay silent**if** v received X **then** BROADCAST an arbitrary message Y **else** stay silent**if** v is active **return** "=0"**if** v received X **return** "=1"**if** v received Y **return** "=2"**return** ">2"

Lemma 3. Let $A \subseteq V$ be any set of active nodes. After DISTTOACTIVE terminates, a fixed node v correctly learns its distance to the nearest active node as 1, 2, or more than 2 with probability at least $1 - O\left(\frac{1}{\Delta^2(\log \log n)^2}\right)$. If v 's distance to the nearest active node is 0 then v learns it as such with probability 1. The running time of DISTTOACTIVE is $O(\log^2 \Delta \log \log \log n)$ rounds.

Lastly, we give BROADCAST which spreads information among nodes.

Algorithm 4 BROADCAST for node v

Input: a message to broadcast**for** $O(\log \Delta \log \log \log n)$ times **do**▷ Outermost iteration**for** $i = 1, 2, \dots, O(\log \Delta)$ **do**▷ Innermost iteration v broadcasts its message with probability 2^{-i}

Lemma 4. Let $A \subseteq V$ be any set of nodes broadcasting the same message, while other nodes $V \setminus A$ are listening. After BROADCAST terminates, a node v with at least one broadcasting neighbor will receive the message with probability at least $1 - O\left(\frac{1}{\Delta^2(\log \log n)^2}\right)$. Nodes without neighbors will not receive any messages. The running time of BROADCAST is $O(\log^2 \Delta \log \log \log n)$ rounds.

Proof of Lemma 4 (BROADCAST). Call nodes in A **informed** and let m be the message known by nodes in A . Let the number of informed neighbors of v be $[2^k, 2^{k+1})$ for $k \leq \log_2 \Delta$. An easy calculation shows that during the innermost iteration when $i = k$, v will receive the message with

probability $\Omega(1) \cdot p$. Since $p = \Omega(1)$, we have proven v receives m with constant probability in each outermost iteration. There are $O(\log \Delta \log \log \log n)$ outermost iterations. Thus, the probability that v never receives a message is at most $\exp(-O(\log \Delta \log \log \log n)) \leq O\left(\frac{1}{\Delta^2 (\log \log n)^2}\right)$. Lastly, a running time of $O(\log^2 \Delta \log \log \log n)$ follows by the definition of BROADCAST. \square

Proof of Lemma 3 (DISTTOACTIVE). Let u be v 's nearest active node. The cases when $\text{dist}(v, u) = 0$ and $\text{dist}(v, u) > 2$ are trivial by definition of DISTTOACTIVE. Consider when $\text{dist}(v, u) = 2$. Let w be a mutual neighbor of v and u . The probability v does not learn its distance as 2 is at most the probability that w does not receive X or v does not receive Y . By Lemma 4 and a union bound this probability is at most $O\left(\frac{1}{\Delta^2 (\log \log n)^2}\right)$. Lastly, the case when $\text{dist}(v, w) = 1$ holds for similar reasons. The running time of DISTTOACTIVE follows from the running time of BROADCAST. \square

Proof of Lemma 2 (LEARNDELAYS). Let $v \in V$ be a most delayed node in its 2-hop neighborhood. The main idea of this proof is to show that nodes in $\Gamma(v)$ always update their binary search parameters in exactly the same manner as v . Furthermore, we show that, while nodes in $\Gamma^{(2)}(v) \setminus \Gamma(v)$ might update their parameters differently, these nodes never interfere with the binary search performed by nodes in $\Gamma(v)$.

By Lemma 3 and a union bound over v 's at most Δ^2 2-hop neighbors and the $O(\log \log n)$ rounds of LEARNDELAYS, we have that every 2-hop neighbor of v correctly learns its distance to an active node with constant probability in every round of LEARNDELAYS. From this point on in the proof we condition on every 2-hop neighbor of v correctly learning its distance to an active node in every iteration of LEARNDELAYS. We say that nodes v and w **deviate** if at some point v and w have different values for lo or hi . For any variable α of LEARNDELAYS we let $\alpha_i(v)$ stand for v 's value of α in iteration i . For example, $hi_i(v)$ is v 's value of hi in iteration i of LEARNDELAYS.

We show that three properties hold in every iteration i of LEARNDELAYS by induction over i : (1) v is not marked silent; (2) $u \in \Gamma(v)$ does not deviate from v ; (3) if $w \in \Gamma^{(2)}(v) \setminus \Gamma(v)$ deviates from v in iteration i then w is not active in iteration j for any $j > i$. (1) and (2) will show that nodes in $\Gamma(v)$ update their binary search parameters appropriately and (3) will show that any node which fails to do so will never interfere with the binary search of nodes in $\Gamma(v)$.

Our base case for the 0th iteration is trivial. (1) holds since v is not initially marked silent. (2) holds since every node initializes hi and lo to the same values and so $u \in \Gamma(v)$ initializes hi and lo to the same values as v . (3) holds since no w deviates from v initially.

We now show our inductive step. Assume as an inductive hypothesis that in every iteration $i' < i$ we have that (1), (2) and (3) hold. We now show that (1), (2) and (3) hold in iteration i .

- (1) We would like to show that v is not marked silent in iteration i . Assume for the sake of contradiction that v is marked silent. v being marked silent means that v is not active, meaning $t_v > \lfloor \frac{lo_i(v) + hi_i(v)}{2} \rfloor$, but that there is a node in $w \in \Gamma^{(2)}(v) \setminus \Gamma(v)$ that is active, meaning $t_w \leq \lfloor \frac{lo_i(w) + hi_i(w)}{2} \rfloor$. By (3) of our inductive hypothesis we know that w has not deviated from v , meaning $\frac{lo_i(w) + hi_i(w)}{2} = \frac{lo_i(v) + hi_i(v)}{2}$ and so we then have

$$\begin{aligned}
t_w &\leq \lfloor \frac{lo_i(w) + hi_i(w)}{2} \rfloor \\
&= \lfloor \frac{lo_i(v) + hi_i(v)}{2} \rfloor \\
&< t_v
\end{aligned}$$

Thus, $t_w < t_v$. However, since $t_w \in \Gamma^{(2)}(v)$ this contradicts the fact that t_v is most delayed in its 2-hop neighborhood. Thus, we conclude that, in fact, in iteration i it holds that v is not marked silent.

- (2) We would like to show that in iteration i it holds that $u \in \Gamma(v)$ does not deviate from v , i.e. $hi_{i+1}(u) = hi_{i+1}(v)$ and $lo_{i+1}(u) = lo_{i+1}(v)$. We case on whether or not in iteration i we have $t_v \leq \lfloor \frac{lo_i(v) + hi_i(v)}{2} \rfloor$.

- Suppose that $t_v \leq \lfloor \frac{lo_i(v) + hi_i(v)}{2} \rfloor$. By (1) of our induction hypothesis v has not been marked silent and so in this case v is active. If v is active then for any $u \in \Gamma(v)$ (where potentially $u = v$ since $v \in \Gamma(v)$) we have $\text{dist}_i(u) \leq 1$ and so $hi_{i+1}(u) \leftarrow \lfloor \frac{lo_i(u) + hi_i(u)}{2} \rfloor$ and $lo_{i+1}(u) \leftarrow lo_i(u)$. By (2) of our induction hypothesis we have that $lo_i(u) = lo_i(v)$ and $hi_i(v) = hi_i(u)$ for every $u \in \Gamma(v)$. Thus, for $u \in \Gamma(v)$ we have $lo_{i+1}(u) \leftarrow lo_i(u) = lo_i(v) = lo_{i+1}(v)$ and $hi_{i+1}(u) \leftarrow \lfloor \frac{lo_i(u) + hi_i(u)}{2} \rfloor = \lfloor \frac{lo_i(v) + hi_i(v)}{2} \rfloor = hi_{i+1}(v)$. Thus, in this case v and u do not deviate.
- Suppose that $t_v > \lfloor \frac{lo_i(v) + hi_i(v)}{2} \rfloor$ in iteration i . Combining the fact that v is most delayed in its two-hop neighborhood, with (2) of our inductive hypothesis it follows that $\text{dist}_i(v) \geq 2$. Now assume for the sake of contradiction that u deviates from v in this iteration. That is, $\text{dist}_i(u) \leq 1$. Since $\text{dist}_i(v) \geq 2$ we know that u must deviate from v because there is an active node in $w \in \Gamma^{(2)}(v) \setminus \Gamma(v)$. However, by (3) of our inductive hypothesis any such node must have not deviated from v . Since v is most delayed in its two-hop neighborhood it follows that $t_w \geq t_v \lfloor \frac{lo_i(v) + hi_i(v)}{2} \rfloor = \lfloor \frac{lo_i(w) + hi_i(w)}{2} \rfloor$ which contradicts the fact that w is active. Thus, in this case u must not deviate from v .

- (3) We would like to show that if $w \in \Gamma^{(2)}(v) \setminus \Gamma(v)$ deviates from v in iteration i then w is not active in iteration j for any $j > i$. We demonstrate this by showing that any such w is either marked silent in iteration i or in every subsequent iteration t_w is outside of the range over which w is searching. Consider a w that deviates from v . w deviates if $\text{dist}_i(v) \leq 1$ but $\text{dist}_i(w) \geq 2$ or $\text{dist}_i(w) \leq 1$ but $\text{dist}_i(v) \geq 2$. Consider each case.

- Suppose $\text{dist}_i(v) \leq 1$ but $\text{dist}_i(w) \geq 2$. First notice that in this case v is active since v is minimal in its two-hop neighborhood and by (1) of our inductive hypothesis v is not silent. Thus, since v is active and v is at most two hops from w we have $\text{dist}_i(w) \leq 2$, meaning that $\text{dist}_i(w) = 2$. However, this means that w is marked as silent and will therefore never be active in any iteration $j > i$.
- Suppose $\text{dist}_i(w) \leq 1$ but $\text{dist}_i(v) \geq 2$. By (3) of our inductive hypothesis we have that $lo_i(v) = lo_i(w)$ and $hi_i(v) = hi_i(w)$. Moreover, since $\text{dist}_i(v) \geq 2$ we know that in iteration

i it holds that $t_v > \lfloor \frac{lo_i(v)+hi_i(v)}{2} \rfloor$. Since v is minimal in its two-hop neighborhood we have that $t_v \leq t_w$. Combining these facts we have that

$$\begin{aligned} t_w &\geq t_v \\ &> \left\lfloor \frac{lo_i(v) + hi_i(v)}{2} \right\rfloor \\ &= \left\lfloor \frac{lo_i(w) + hi_i(w)}{2} \right\rfloor \end{aligned}$$

Thus, $t_w > \left\lfloor \frac{lo_i(w)+hi_i(w)}{2} \right\rfloor$. Moreover, since $\text{dist}_i(w) \leq 2$ we know that $hi_{i+1}(w) = \left\lfloor \frac{lo_i(w)+hi_i(w)}{2} \right\rfloor$ and so $t_w > hi_{i+1}(w)$. Since hi is non-increasing over iterations—i.e. $hi_{j+1}(w) \leq hi_j(w)$ for j and any w —we will have that in every iteration $j > i$ it holds that $t_w > hi_{i+1}(w) \geq hi_j(w) \geq \left\lfloor \frac{lo_j(w)+hi_j(w)}{2} \right\rfloor$ meaning that w cannot be active in iteration j since w is only active in iteration j when $t_w \leq \left\lfloor \frac{lo_j(w)+hi_j(w)}{2} \right\rfloor$.

Having shown our induction we now argue that the value that v will learn from its binary search is t_v , it's virtual round. In particular, we argue that v always updates its binary search parameters according to t_v . That is, in iteration i we have v reduces hi when $t_v \leq \left\lfloor \frac{lo_i(v)+hi_i(v)}{2} \right\rfloor$ and v increases lo when $t_v > \left\lfloor \frac{lo_i(v)+hi_i(v)}{2} \right\rfloor$.

- If v updates hi in iteration i then there must be some node $u \in \Gamma(v)$ which is active. That is, $t_u \leq \left\lfloor \frac{lo_i(u)+hi_i(u)}{2} \right\rfloor$. By (2) we have $lo_i(u) = lo_i(v)$ and $hi_i(u) = hi_i(v)$ and by the fact that v is most delayed in its two-hop neighborhood we know that $t_v \leq t_u$. Thus $t_v \leq t_u \leq \left\lfloor \frac{lo_i(u)+hi_i(u)}{2} \right\rfloor = \left\lfloor \frac{lo_i(v)+hi_i(v)}{2} \right\rfloor$.
- If v updates lo then no node in $\Gamma(v)$ is active and so certainly v itself is not active. But since v is never marked silent by (1) it must not be active because $t_v > \left\lfloor \frac{lo_i(v)+hi_i(v)}{2} \right\rfloor$.

In either case we have that v always updates its binary search parameters according to t_v and so we have that v will return t_v from its binary search.

Thus, v learns as its binary search value t_v but since no node in $\Gamma(v)$ deviates from v so too does every node in $\Gamma(v)$. Recalling that we conditioned on the fact that every node in $\Gamma^{(2)}(v)$ always learns its distance to an active neighbor correctly which happens with constant probability, we conclude our claim. Lastly, our running time comes from straightforwardly summing the running time of subroutines and noting that by assumption every value we are binary searching over lies within a $O(\log n)$ range. \square

Proof of Lemma 1 (MAINSTATIC). Fix a v that is most delayed in its 2-hop neighborhood such that $t_v < L$. Note that by definition of a virtual round and the fact that $t_v < L$ we have that $P(v, t_v)$ is a listening action where in round t_v of P it holds that v is sent a message without collision. By Lemma 2 after LEARNDELAYS terminates with constant probability each 1-hop neighbor w will have $m_w = t_v$. Thus, every node in the 1-hop neighborhood of v will simulate round t_v , i.e. the one neighbor that has a message for v will broadcast its message and the rest of v 's neighbors

will be silent. This message will be successfully received with probability p which is constant by assumption and so t_v will be incremented with constant probability. The running time follows by summing subroutines. \square

Proof of Theorem 2. Let $Q := O(\log n)$. We will prove the following subclaim: Assume that for every vertex v we have $L - Q \leq t_v \leq L$; letting t'_v be v 's virtual round after Q outermost iterations of MAINSTATIC we have $L \leq t'_v \leq L + Q$ w.h.p.

Note that this subclaim immediately proves the theorem. The length of P is $\text{poly}(n)$ by assumption and so we can divide P into $\text{poly}(n)$ chunks of rounds each of size Q . By induction and a union bound over chunks we have that after KQ outermost iterations of MAINSTATIC it holds that for every node v we have $QK \leq t_v \leq QK + 1$ w.h.p. Letting $K = \frac{|P|}{Q}$ yields that with high probability after $T + Q$ rounds every node v is such that $|P| \leq t_v$, yielding our theorem.

We now prove the subclaim. Note that the assumption of our subclaim is that the preconditions of Lemma 1 are satisfied. For simplicity and without loss of generality we assume $L = 0$. Let $x \in \mathbb{Z}_{\geq 1}$ and define $D_{v,x}$ as the random variable giving the index of the earliest innermost iteration of MAINSTATIC when $t_v \geq x$. Using Lemma 1 we get the following recurrence relation. $D_{v,x} \leq \min_{w \in \Gamma^{(2)}(v)} D_{w,x-1} + \mathcal{G}_{v,x}(q)$, where q is the constant probability of an inner iteration of MAINSTATIC advancing a node most delayed in its 2-hop neighborhood given by Lemma 1.

We now prove a tail bound for $D_{v,x}$ by union bounding over all ‘‘blaming chains.’’ A blaming chain for $D_{v,x}$ is a sequence of nodes paired with simulated rounds that could explain why $D_{v,x}$ took as long as it did. In particular, a blaming chain C for $D_{v,x}$ is a sequence of (node, round) tuples $(v_x, x), (v_{x-1}, x-1), \dots, (v_1, 1)$ where $v_i \in \Gamma^{(2)}(v_{i-1})$ and $v_x = v$. We let $\mathcal{C}(D_{v,x})$ stand for such blaming chains. We say $|C| := \sum_{(v_i, i) \in C} \mathcal{G}_{v_i, i}$ is the length of blaming chain C . Note that the size of $\mathcal{C}(D_{v,x})$ is at most $(\Delta^2)^{x-1}$. Also notice that $D_{v,x}$ just is the length of the longest blaming chain in $\mathcal{C}(D_{v,x})$. Thus, we have that

$$\begin{aligned} D_{v,x} &= \max_{w \in \Gamma^{(2)}(v)} D_{w,x-1} + \mathcal{G}_{v,x} \\ &= \max_{C \in \mathcal{C}(D_{v,x})} |C| \end{aligned}$$

As such, to show an upper bound on $D_{v,x}$ it suffices to show that no blaming chain is too long. Notice that the length of a blaming chain in $\mathcal{C}(D_{v,x})$ just is the sum of x geometric random variables with constant expectation. Lemma 10 of Appendix A gives a Chernoff-style tail bound for such sums and asserts that for any fixed blaming chain C in $\mathcal{C}(D_{v,Q})$ we have $\Pr[|C| \geq c(Q \log \Delta + k)] \leq \exp(-k)$ for some constant $c > 0$. A union bound over all blaming chains of all nodes gives us that $\Pr[\exists v \in V, D_{v,Q} \geq c(Q \log \Delta + k)] \leq n(\Delta^2)^{Q-1} \exp(-k)$. Setting $k \leftarrow 2Q \ln \Delta + O(\ln n)$, all $D_{v,Q} = O(Q \log \Delta + \log n) = O(\log n \log \Delta)$ w.h.p. Note that $D_{v,Q}$ counts innermost iterations, hence it takes $\frac{D_{v,Q}}{c \log \Delta}$ outermost iterations for the condition to be satisfied. Moreover, c is the constant in the iteration range of the innermost for loop of MAINSTATIC and Q does not depend on it. Hence we can set $c > 0$ sufficiently large such that $\frac{D_{v,Q}}{c \log \Delta} = \frac{O(\log n)}{c} \leq Q$. Having shown that the number of outer iterations for every variable to arrive at virtual round Q is at most Q , we conclude the subclaim. As we earlier argued, this gives our theorem. Note that our running time follows from summing the runtimes of our subroutines. \square

5 General Protocol Simulation

Here, we provide our results for arbitrary protocols. Our approach gives a $O(\Delta \log \Delta)$ multiplicative overhead.

Theorem 3. *Let P be a general protocol of length T for the faultless radio network model. The simulation routine `MAINGENERAL` simulates P in the noisy radio setting with high probability. The simulation takes $O((T + \log n)\Delta \log \Delta)$ rounds.*

Again, we build on the notion of a virtual round for this setting. Our main challenge in this setting is that even if a node knows its neighbors are simulating its virtual round, the node cannot tell if the absence of a message indicates that it receives no message in this round in the original protocol or that a random fault occurred. As such, in order for node v to advance its virtual round after hearing no messages from a neighbor, v must confirm that every neighbor was silent in the simulated round. Let P be the original protocol for the faultless setting. Define the **token** for a node v in round r of P to be either the message that v is sending in round r of P or an arbitrary message indicating “ v is not broadcasting” if v is silent in round r of P . Next, we (re-)define the **virtual round** of a node v to be the largest $t_v \in \mathbb{Z}_{\geq 1}$ such that v successfully received *all tokens* from all neighbors for rounds $1, 2, \dots, t_v - 1$ (for a total of up to $(t_v - 1)\Delta$ tokens).

Our simulation algorithm works in two phases: every node first informs its neighbors of its virtual round; next, nodes help the neighbor with the smallest t_v they saw by sharing the token for that round. We now present pseudocode for the `SHAREKNOWLEDGE` routine which shares messages from a node with all of its neighbors and `MAINGENERAL` which simulates P in the noisy setting.

Algorithm 5 `SHAREKNOWLEDGE` for node v

Input: a message, B_v , that v wants to share

for $O(\Delta \log \Delta)$ rounds **do**

v broadcasts B_v with probability $\frac{1}{\Delta}$, independently from other nodes

Lemma 5. *After `SHAREKNOWLEDGE` terminates, a fixed node v successfully receives messages from all its neighbors with probability at least $3/4$ and successfully sends its message to all neighbors with probability at least $3/4$. The running time of `SHAREKNOWLEDGE` is $O(\Delta \log \Delta)$ rounds.*

Proof. Fix an arbitrary node v . Consider the event where v receives a message from a fixed neighbor w in a fixed iteration of `SHAREKNOWLEDGE`. This event occurs iff w broadcasts and all other neighbors of v , namely $\Gamma(v) \setminus \{w, v\}$, do not broadcast. This occurs with probability that is at least $\frac{1}{\Delta}(1 - \frac{1}{\Delta})^{|\Gamma(v) \setminus \{w, v\}|} \geq \frac{1}{\Delta}(1 - \frac{1}{\Delta})^\Delta \geq \Omega(\frac{1}{\Delta})$ by $(1 - \frac{1}{x})^x = \Omega(1)$. The probability that v does not hear from w after $O(\Delta \log \Delta)$ iterations is $(1 - \Omega(\frac{1}{\Delta}))^{\Delta \log \Delta} \leq \exp(-\Omega(\log \Delta)) \leq \frac{1}{4\Delta}$. Union bounding over all $|\Gamma(v)| \leq \Delta$ possibilities for w we get that the probability of v not sharing knowledge with all neighbors is at most $1/4$. \square

Algorithm 6 `MAINGENERAL` for node v

$t_v \leftarrow 1$

for $O(T \log \Delta + \log n)$ **do**

$m_v \leftarrow \text{SHAREKNOWLEDGE}(t_v)$

`SHAREKNOWLEDGE`(token for virtual round m_v)

update t_v if v received all tokens for round t_v

Lemma 6. *Let v be a most delayed node in its 2-hop neighborhood. After one MAINGENERAL loop iteration, t_v will increase by one with at least constant probability.*

Proof. Fix a node v that is most delayed in its 2-hop neighborhood. By Lemma 5 and a union bound over v 's at most Δ neighbors, the probability that the first call to SHAREKNOWLEDGE successfully shares v 's message to all of its neighbors, and that all of v 's neighbors successfully share their tokens with v is at least $\frac{1}{2}$. Since v is minimal in its 2-hop neighborhood it follows that $m_w = t_v$ for $w \in \Gamma(v)$. Thus, v will receive a token from every neighbor for its virtual round with probability at least $\frac{1}{2}$, meaning that v increments its virtual round by one with constant probability. \square

Proof of Theorem 3. We use the same blaming chain proof technique as in Theorem 2 but use Lemma 6 instead of Lemma 1. The proof is completely analogous and hence omitted. \square

6 Lower bounds

In this section we argue that an $\Omega(\text{poly log } \Delta)$ multiplicative overhead in simulation is necessary in two natural settings. In the first setting the simulation is not permitted to use network coding [1]. In the second setting the simulation must respect information flow in the sense that it must broadcast messages from the same nodes. It follows that any simulation with constant overhead either uses network coding or does not respect information flow. We also give a protocol which we conjecture requires $\Omega(\text{poly log } \Delta)$ multiplicative overhead in simulation even if the simulation protocol does use network coding or does not respect information flow.

Additionally, we strengthen our lower bounds by proving them in the setting in which the simulation is granted “global control”. Informally, global control outfits the network with a centralized scheduler that can synchronize nodes based on how faults occur, but which cannot read the actual contents of the messages. Formally, global control is as follows.

Definition 4 (Global Control). *We say that a noisy radio network has global control when (1) nodes know the network topology and (2) nodes learn which nodes broadcast in each round and at which nodes receiver faults occur in each round.*

It is not difficult to see that access to global control is sufficient to achieve the local progress detection of Section 4.1. Moreover, notice that our simulation from Section 4.1 with $O(\log \Delta)$ multiplicative overhead is both non-coding and respects information flow. As such, it is optimal for both settings.

6.1 Non-Coding Simulations

We now define a non-coding protocol and prove that simulation protocols that are non-coding protocol must have a $\Omega(\log \Delta)$ multiplicative round overhead.

Definition 5 (Non-Coding). *We say that a simulation P' in the noisy setting, which is simulating a protocol P in the faultless setting, is non-coding if any message sent in P' is also sent in P (though possibly by different nodes).*

Lemma 7. *For any $T \geq 1$ and sufficiently large Δ there exists a faultless protocol of length T on the star network with $\Delta + 1$ nodes such that any non-coding simulation of the protocol in the noisy setting with constant success probability requires $\Omega(T \log \Delta)$ many rounds even if the simulation has access to global control.*

Proof. As noted, the network is a star with Δ leaves. Let r be the central node of the star. In our faultless protocol, r receives T private inputs M_1, M_2, \dots, M_T each of $\Theta(\log n)$ bits. r takes T rounds to broadcast each input, broadcasting M_i at round i .

Now consider a simulation of our protocol and assume for the sake of contradiction that it succeeds with constant probability. Let $C = C(p)$ be a constant such that $1 - p \geq \exp(-C)$ where $p = \Omega(1)$ is the fault probability of our noisy network. By the non-coding assumption, all messages sent by P' must be in the set $\{M_1, \dots, M_T\}$. Denote by t_i the number of times r broadcasts M_i . For the sake of contradiction, assume that $\sum_{i=1}^T t_i \leq \frac{1}{100C} T \log \Delta$. Hence $\min_{i \in [T]} t_i \leq \frac{1}{100C} \log \Delta$ by an averaging argument. Let $i^* = \arg \min_{i \in [T]} t_i$. Notice that the probability that a fixed node receives a message is independent of that of any other node since WLOG only r ever broadcasts. Therefore, the probability that a fixed node does not receive M_{i^*} is $(1 - p)^{t_{i^*}} \geq (1 - p)^{\frac{1}{100C} \log \Delta} \geq \exp(-C \frac{1}{100C} \log \Delta) \geq \Delta^{-1/100}$ by definition of C . Consequently, the probability that some node does not receive i^* is at least $1 - (1 - \Delta^{-1/100})^\Delta \geq 1 - \exp(-\Delta^{99/100})$ which tends to 1 as $\Delta \rightarrow \infty$. This contradicts our assumption that our simulation succeeds with constant probability. Therefore, no simulation protocol of length $\Omega(T \log \Delta)$ can deliver all messages with constant probability. \square

6.2 Simulations that Respect Information Flow

The preceding lower bound assumed that in the original protocol a node had access to T private inputs each of size $\Theta(\log n)$ bits. We now demonstrate that even if nodes in the original protocol are given only a single private of size $\Theta(\log n)$ bits then there exists a protocol whose simulation requires $\Omega(\log \Delta)$ multiplicative overhead, provided the simulation respects information flow. We now formally define respecting information flow and state the lower bound lemma.

Definition 6 (Respect Information Flow). *We say that a simulation protocol P' of a protocol P respects information flow if node v broadcasts a message m only if v broadcasts m in P .*

Lemma 8. *Let $G = (L \cup R, E)$ be a complete bipartite graph with $|L| = |R| = \Delta$. There exists a protocol P of length Δ for the faultless setting on G such that any simulation that respects information flow of the protocol on G in the noisy setting with constant success probability requires $\Omega(\Delta \log \Delta)$ rounds. This bound holds even in the global control setting.*

6.3 Conjectured Unconditional Lower Bound

We believe the following protocol for the faultless setting requires an $\Omega(\text{poly}(\log \Delta))$ multiplicative overhead for any simulation in the noisy setting.

Let G be a bipartite network with partition (L, R) , where $|L| = |R| = n$. Divide the nodes in L and R each into Δ groups of size $\frac{n}{\Delta}$, L_1, \dots, L_Δ and R_1, \dots, R_Δ respectively. Let $l_1^i, \dots, l_{n/\Delta}^i$ be the nodes in L_i and let $r_1^i, \dots, r_{n/\Delta}^i$ be the nodes in R_i . For every $i \in [\Delta]$ and $j \in [n/\Delta]$ we connect l_j^i to $r_j^{i'}$ for $i' \in [\Delta]$. The resulting network is a Δ -regular graph. See Figure 3. Our faultless protocol on G is as follows. Each node $r \in R$ has a private input of $\Theta(\log n)$ bits. In the i th round every node in R_i broadcasts its private input. Note that there are no collisions in this protocol.

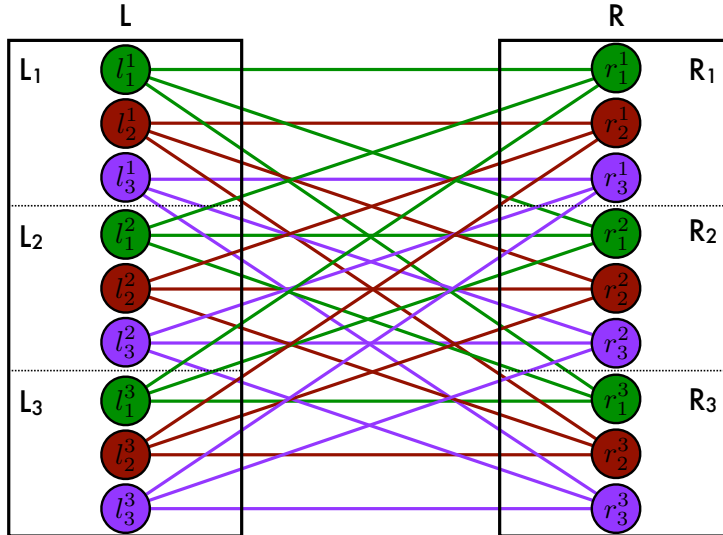

Figure 3: Our conjectured lower bound network for $\Delta = 3$, $n = 9$. Nodes colored according to indices within L_i and R_i . Edges colored according to endpoints.

7 Conclusion

In this paper we explored the computational power of noisy radio networks relative to classic radio networks. We demonstrated that any static radio network protocol can be simulated with a multiplicative cost of $\text{poly}(\log \Delta, \log \log n)$ rounds. Moreover, we demonstrated that a general radio network protocol can be simulated with a multiplicative $O(\Delta \log \Delta)$ round-overhead. We also showed lower bounds that suggest that any simulation of a radio network protocol by a noisy radio network requires $\Omega(\log \Delta)$ additional rounds multiplicatively.

Though we give a simulation for general protocols, the main focus of technical content of this work has been static protocols. Static protocols capture a number of well-known protocols (e.g. the optimal broadcast algorithm of Gąsieniec et al. [22]) and this focus has enabled us to understand both how delays propagate (see our blaming chain arguments) and how to efficiently exchange information among nodes (see our distributed binary search) in noisy radio networks. Having given solutions to these challenges, we now state promising directions for future work in noisy radio networks.

First, it is an open question how to deal with neighbors with diverging notions of when one another send messages in the simulated protocol. This is not an issue in static protocols and our general protocol solves this issue but only through a costly subroutine in which every node shares information with all of its neighbors. Thus, it remains unknown how such diverging perspectives might be dealt with and if a solution to this issue might expedite simulation time. “Backtracking” on faulty progress has been the subject of some interactive coding literature—see Haeupler [24]—and will likely prove insightful on this front.

Second, the necessity of acknowledgements in simulations in noisy radio networks remains open. In our static protocol simulation we do not require that receivers send a message to senders acknowl-

edging that they have successfully received the broadcast message. Though our general protocol simulation solves this issue with a $O(\Delta \log \Delta)$ round overhead, we leave as an open question whether some form of a poly $\log \Delta$ solution for acknowledgements is possible³ and whether such a solution is even necessary for efficient simulation. Lastly, we note that this question ties in nicely with past work on MAC layers [20; 27] where acknowledgments in a wireless setting are required.

As a final direction for future work we note that many of our techniques apply to simulations of faulty versions of other models of distributed computing. For instance, applying the techniques of our general protocol simulation to a receiver fault version of CONGEST almost immediately yields a simulation of CONGEST with receiver faults by CONGEST with a $O(\log \Delta)$ multiplicative round overhead. We expect further applications abound.

³Such a solution could not simply have every neighbor receiver send a message to the sender as this would require $\Omega(\Delta)$ rounds.

References

- [1] R. Ahlswede, Ning Cai, S. Y.R. Li, and R. W. Yeung. Network information flow. *IEEE Trans. Inf. Theor.*, 46(4):1204–1216, September 2006. ISSN 0018-9448. doi: 10.1109/18.850663. URL <http://dx.doi.org/10.1109/18.850663>.
- [2] Noga Alon, Amotz Bar-Noy, Nathan Linial, and David Peleg. A lower bound for radio broadcast. *Journal of Computer and System Sciences*, 43(2):290–298, 1991.
- [3] Hagit Attiya and Jennifer Welch. *Distributed Computing. Fundamentals, Simulations, and Advanced Topics*. McGraw-Hill, 1998.
- [4] Baruch Awerbuch. Complexity of network synchronization. *J. ACM*, 32(4):804–823, October 1985. ISSN 0004-5411. doi: 10.1145/4221.4227. URL <http://doi.acm.org/10.1145/4221.4227>.
- [5] Baruch Awerbuch and David Peleg. Network synchronization with polylogarithmic overhead. In *Proceedings of the 31st Annual Symposium on Foundations of Computer Science, SFCS '90*, pages 514–522 vol.2, Washington, DC, USA, 1990. IEEE Computer Society. ISBN 0-8186-2082-X. doi: 10.1109/FSCS.1990.89572. URL <http://dx.doi.org/10.1109/FSCS.1990.89572>.
- [6] Reuven Bar-Yehuda, Oded Goldreich, and Alon Itai. On the time-complexity of broadcast in multi-hop radio networks: An exponential gap between determinism and randomization. *Journal of Computer and System Sciences*, 45(1):104–126, 1992.
- [7] Mark Braverman, Klim Efremenko, Ran Gelles, and Bernhard Haeupler. Constant-rate coding for multiparty interactive communication is impossible. *Journal of the ACM (JACM)*, 65(1):4, 2017.
- [8] Keren Censor-Hillel, Seth Gilbert, Fabian Kuhn, Nancy A. Lynch, and Calvin C. Newport. Structuring unreliable radio networks. *Distributed Computing*, 27(1):1–19, 2014. doi: 10.1007/s00446-013-0198-8. URL <http://dx.doi.org/10.1007/s00446-013-0198-8>.
- [9] Keren Censor-Hillel, Bernhard Haeupler, D. Ellis Hershkowitz, and Goran Zuzic. Broadcasting in noisy radio networks. In *PODC*, 2017.
- [10] Keren Censor-Hillel, Bernhard Haeupler, Jonathan A. Kelner, and Petar Maymounkov. Rumor spreading with no dependence on conductance. *SIAM J. Comput.*, 46(1):58–79, 2017. doi: 10.1137/14099992X. URL <https://doi.org/10.1137/14099992X>.
- [11] Keren Censor-Hillel, Ran Gelles, and Bernhard Haeupler. Making asynchronous distributed computations robust to channel noise. In *9th Innovations in Theoretical Computer Science Conference, ITCS 2018, January 11-14, 2018, Cambridge, MA, USA*, pages 50:1–50:20, 2018. doi: 10.4230/LIPIcs.ITCS.2018.50. URL <https://doi.org/10.4230/LIPIcs.ITCS.2018.50>.
- [12] I. Chlamtac and S. Kutten. On broadcasting in radio networks - problem analysis and protocol design. *IEEE Transactions on Communications*, 33(12):1240–1246, December 1985. ISSN 0090-6778. doi: 10.1109/TCOM.1985.1096245.

- [13] Artur Czumaj and Wojciech Rytter. Broadcasting algorithms in radio networks with unknown topology. *Journal of Algorithms*, 60(2):115 – 143, 2006. ISSN 0196-6774. doi: <http://dx.doi.org/10.1016/j.jalgor.2004.08.001>. URL [//www.sciencedirect.com/science/article/pii/S0196677404001439](http://www.sciencedirect.com/science/article/pii/S0196677404001439).
- [14] Abbas El-Gamal. Open problems presented at the 1984 workshop on specific problems in communication and computation. *Sponsored by bell communication research*, 1984.
- [15] Moncef Elaoud and Parameswaran Ramanathan. Adaptive use of error-correcting codes for real-time communication in wireless networks. In *INFOCOM'98. Seventeenth Annual Joint Conference of the IEEE Computer and Communications Societies. Proceedings. IEEE*, volume 2, pages 548–555. IEEE, 1998.
- [16] Robert G. Gallager. Finding parity in a simple broadcast network. *IEEE Trans. Information Theory*, 34(2):176–180, 1988. doi: 10.1109/18.2626. URL <http://dx.doi.org/10.1109/18.2626>.
- [17] Ran Gelles et al. Coding for interactive communication: A survey. *Foundations and Trends® in Theoretical Computer Science*, 13(1–2):1–157, 2017.
- [18] Mohsen Ghaffari, Bernhard Haeupler, Nancy A. Lynch, and Calvin C. Newport. Bounds on contention management in radio networks. In *Distributed Computing - 26th International Symposium, DISC 2012, Salvador, Brazil, October 16-18, 2012. Proceedings*, pages 223–237, 2012. doi: 10.1007/978-3-642-33651-5_16. URL http://dx.doi.org/10.1007/978-3-642-33651-5_16.
- [19] Mohsen Ghaffari, Nancy A. Lynch, and Calvin C. Newport. The cost of radio network broadcast for different models of unreliable links. In *PODC '13, Montreal, QC, Canada, July 22-24, 2013*, pages 345–354, 2013. doi: 10.1145/2484239.2484259. URL <http://doi.acm.org/10.1145/2484239.2484259>.
- [20] Mohsen Ghaffari, Erez Kantor, Nancy Lynch, and Calvin Newport. Multi-message broadcast with abstract mac layers and unreliable links. In *Proceedings of the 2014 ACM symposium on Principles of distributed computing*, pages 56–65. ACM, 2014.
- [21] Mohsen Ghaffari, Bernhard Haeupler, and Majid Khabbazi. Randomized broadcast in radio networks with collision detection. *Distributed Computing*, 28(6):407–422, 2015.
- [22] Leszek Gąsieniec, David Peleg, and Qin Xin. Faster communication in known topology radio networks. *Distributed Computing*, 19(4):289–300, 2007.
- [23] Navin Goyal, Guy Kindler, and Michael E. Saks. Lower bounds for the noisy broadcast problem. *SIAM J. Comput.*, 37(6):1806–1841, 2008. doi: 10.1137/060654864. URL <http://dx.doi.org/10.1137/060654864>.
- [24] Bernhard Haeupler. Interactive channel capacity revisited. In *Foundations of Computer Science (FOCS), 2014 IEEE 55th Annual Symposium on*, pages 226–235. IEEE, 2014.
- [25] Bernhard Haeupler and David Wajc. A faster distributed radio broadcast primitive. In *Proceedings of the 2016 ACM Symposium on Principles of Distributed Computing*, pages 361–370. ACM, 2016.

- [26] Dariusz R. Kowalski and Andrzej Pelc. Optimal deterministic broadcasting in known topology radio networks. *Distributed Computing*, 19(3):185–195, 2007.
- [27] Fabian Kuhn, Nancy Lynch, and Calvin Newport. The abstract mac layer. In *International Symposium on Distributed Computing*, pages 48–62. Springer, 2009.
- [28] Fabian Kuhn, Nancy A. Lynch, Calvin C. Newport, Rotem Oshman, and Andréa W. Richa. Broadcasting in unreliable radio networks. In *Proceedings of the 29th Annual ACM Symposium on Principles of Distributed Computing, PODC 2010, Zurich, Switzerland, July 25-28, 2010*, pages 336–345, 2010. doi: 10.1145/1835698.1835779. URL <http://doi.acm.org/10.1145/1835698.1835779>.
- [29] Fabian Kuhn, Nancy A. Lynch, and Calvin C. Newport. The abstract MAC layer. *Distributed Computing*, 24(3-4):187–206, 2011. doi: 10.1007/s00446-010-0118-0. URL <http://dx.doi.org/10.1007/s00446-010-0118-0>.
- [30] Eyal Kushilevitz and Yishay Mansour. An $\omega(d \log(n/d))$ lower bound for broadcast in radio networks. In *Proceedings of the Twelfth Annual ACM Symposium on Principles of Distributed Computing, PODC '93*, pages 65–74, New York, NY, USA, 1993. ACM. ISBN 0-89791-613-1. doi: 10.1145/164051.164059. URL <http://doi.acm.org/10.1145/164051.164059>.
- [31] Eyal Kushilevitz and Yishay Mansour. Computation in noisy radio networks. In *SODA*, volume 98, pages 236–243, 1998.
- [32] Krijn Leentvaar and Jan Flint. The capture effect in fm receivers. *IEEE Transactions on Communications*, 24(5):531–539, 1976.
- [33] Ilan Newman. Computing in fault tolerance broadcast networks. In *19th Annual IEEE Conference on Computational Complexity (CCC 2004), 21-24 June 2004, Amherst, MA, USA*, pages 113–122, 2004. doi: 10.1109/CCC.2004.1313813. URL <http://dx.doi.org/10.1109/CCC.2004.1313813>.
- [34] David Peleg. *Time-Efficient Broadcasting in Radio Networks: A Review*, pages 1–18. Springer Berlin Heidelberg, Berlin, Heidelberg, 2007. ISBN 978-3-540-77115-9. doi: 10.1007/978-3-540-77115-9_1. URL http://dx.doi.org/10.1007/978-3-540-77115-9_1.
- [35] Sridhar Rajagopalan and Leonard Schulman. A coding theorem for distributed computation. In *Proceedings of the twenty-sixth annual ACM symposium on Theory of computing*, pages 790–799. ACM, 1994.
- [36] Leonard J Schulman. Coding for interactive communication. *IEEE Transactions on Information Theory*, 42(6):1745–1756, 1996.

A Tail Bounds

In this section we prove the tail bounds that we use throughout this paper.

Lemma 9. *Let X_1, \dots, X_n be independent random variables taking on integer values. Let $\mu_i = \mathbb{E}[X_i]$ and suppose that for every i and every $t > 0$ we have $\Pr[X_i - \mu_i \geq t] \leq \exp(-ct)$ for some $c > 0$. Then $\Pr[\sum_{i \in [n]} X_i - \mu_i \geq t] \leq \exp(-\frac{c}{3}t)$ for $t \geq L \cdot n$, where $L > 0$ is a constant that depends only on c .*

Proof. We use $V^+ = \max(V, 0)$ to denote the positive part of a real number; note that $\Pr[(X_i - \mu_i)^+ \geq t] \leq \exp(-ct)$ since probability is bounded above by 1. Fix $t \in \mathbb{Z}_{\geq 0}$; any event where $\sum_{i \in [n]} X_i - \mu_i \geq t$ gives a non-negative integer sequence $u_i = (X_i - \mu_i)^+$ where $\sum_{i \in [n]} u_i \geq t$. This, in turn, gives a non-negative integer sequence $u_i \leq (X_i - \mu_i)^+$ where $\sum_{i \in [n]} u_i = t$, for instance, by arbitrary decreasing positive u_i until the sum is t . We will bound the probability of such a sequence existing.

Fix any non-negative integer sequence $u_i \in \mathbb{Z}_{\geq 0}$ where $\sum_{i \in [n]} u_i = t$ and $u_i \leq (X_i - \mu_i)^+$. It is well-known combinatorial fact that there are $\binom{t+n-1}{n-1} \leq \left(\frac{e(t+n-1)}{n-1}\right)^{n-1} \leq e^n(1 + \frac{t}{n})^n$ such sequences. Fixing one such sequence u_i , we have

$$\begin{aligned} & \Pr[\forall i \in [n], u_i \leq (X_i - \mu_i)^+] \\ & \leq \prod_{i \in [n]} \Pr[(X_i - \mu_i)^+ \geq u_i] \\ & \leq \exp\left(-c \sum_{i \in [n]} u_i\right) = \exp(-ct). \end{aligned}$$

Finally, union bounding over at most $e^n(1 + \frac{t}{n})^n$ sequences, we get $\Pr[\sum_{i \in [n]} X_i - \mu_i \geq t] \leq e^n(1 + \frac{t}{n})^n \exp(-ct)$. We can choose a sufficiently large L such that both $1 + x \leq \exp(\frac{c}{3}x)$ for $x \geq L$, and $e^{1/L} \leq \exp(\frac{c}{3}x)$ hold. In this case $\Pr[\sum_{i \in [n]} X_i - \mu_i \geq t] \leq \exp(\frac{t}{L}) \exp(\frac{c}{3}t) \exp(-ct) \leq \exp(-c/3 \cdot t)$. \square

Lemma 10. *Let Y_1, Y_2, \dots, Y_T be independent maximums of at most $\Delta \geq 2$ independent geometric random variables with constant expectation. Then $\Pr[\sum_{i \in [T]} Y_i \geq C(T \log \Delta + t)] \leq \exp(-t)$ for all $t \geq 0$, where $C > 0$ is a constant.*

Proof. Geometric random variable G with constant expectation have a natural tail bound of the form $\Pr[G \geq t] \leq \exp(-ct)$. Since there are only finitely many geometric random variables in question, we can choose a sufficiently small constant $c > 0$ such that the bound holds for all of them. Consequently, the maximum of at most Δ such variables exhibits a tail bound. Let G_1, G_2, \dots, G_k where $k \leq \Delta$ be geometric random variables with constant expectation and set $Y := \max(G_1, \dots, G_k)$. Then $\Pr[Y \geq t] \leq \sum_{i \in [k]} \Pr[G_i \geq t] \leq \Delta \exp(-ct)$. Setting $\mu := \frac{\ln \Delta}{c}$ and $t \leftarrow t' + \mu$, we get that $\Pr[Y - \mu \geq t'] \leq \exp(-ct')$.

Having obtained a tail bound for Y 's, we can apply Lemma 9, getting

$$\Pr\left[\left(\sum_{i \in [T]} Y_i\right) - T \frac{\log \Delta}{c} \geq t\right] \leq \exp\left(-\frac{c}{3}t\right) \quad \text{when } t \geq L \cdot T.$$

By setting $t \leftarrow L \cdot T + t'$ and $c' := \frac{1}{c} + L$, we get that $\Pr \left[\left(\sum_{i \in [T]} Y_i \right) \geq c' \cdot T \log \Delta + t' \right] \leq \exp(-\frac{c}{3}t')$ for all $t' \geq 0$. Finally, setting $t' \leftarrow \frac{3}{c}t''$ and $C := \max(c', \frac{3}{c})$ we get the final result $\Pr \left[\left(\sum_{i \in [T]} Y_i \right) \geq C(T \log \Delta + t'') \right] \leq \exp(-t'')$ for all $t'' \geq 0$. □