

# Feedback Coding Schemes for the Broadcast Channel with Mutual Secrecy Requirement

Bin Dai, Linman Yu, and Zheng Ma

## Abstract

Recently, the physical layer security (PLS) of the communication systems has been shown to be enhanced by using legal receiver's feedback. The present secret key based feedback scheme mainly focuses on producing key from the feedback and using this key to protect part of the transmitted message. However, this feedback scheme has been proved only optimal for several degraded cases. The broadcast channel with mutual secrecy requirement (BC-MSR) is important as it constitutes the essence of physical layer security (PLS) in the down-link of the wireless communication systems. In this paper, we investigate the feedback effects on the BC-MSR, and propose two inner bounds and one outer bound on the secrecy capacity region of the BC-MSR with noiseless feedback. One inner bound is constructed according to the already existing secret key based feedback coding scheme for the wiretap channel, and the other is constructed by a hybrid coding scheme using feedback to generate not only keys protecting the transmitted messages but also cooperative messages helping the receivers to improve their decoding performance. The performance of the proposed feedback schemes and the gap between the inner and outer bounds are further explained via two examples.

## Index Terms

Feedback, broadcast channel, secrecy capacity region.

B. Dai is with the School of Information Science and Technology, Southwest JiaoTong University, Chengdu 610031, China, and with the State Key Laboratory of Integrated Services Networks, Xidian University, Xi'an, Shaanxi 710071, China, e-mail: daibin@home.swjtu.edu.cn.

L. Yu is with the School of Economics and Management, Chengdu Textile College, Chengdu 611731, China, Email: yulinmanyim@163.com.

Z. Ma is with the School of Information Science and Technology, Southwest JiaoTong University, Chengdu, China, e-mail: zma@home.swjtu.edu.cn.

## I. INTRODUCTION

Besides reliability, introducing an additional secrecy criteria into a physically degraded<sup>1</sup> broadcast channel, Wyner [1] first studied the secure transmission over the wiretap channel (WTC). Later, on the basis of [1], Csiszár and Körner [2] studied the WTC without the “physically degraded” assumption and with an additional common message available at both the legal receiver and the wiretapper. The outstanding work [1]-[2] reveals the reliability-security trade-off of the communication channels in the presence of a wiretapper. The follow-up study of the WTC mainly focuses on the multi-user channel in the presence of a wiretapper (e.g. multiple-access wiretap channel [3], [4], relay-eavesdropper channel [5], [6], broadcast wiretap channel [7], [8], two way wiretap channel [9], [10], etc.), and the multi-terminal security, see [11]-[15].

In recent years, the effect of legal receiver’s feedback on the PLS of communication channels attracts a lot of attention. For the WTC with noiseless feedback (WTC-NF), Ahlswede and Cai [16] pointed out that to enhance the secrecy capacity of the WTC, the best use of the legal receiver’s feedback channel output is to generate random bits from it and use these bits as a key by the transmitter protecting part of the transmitted message. Using this secret key based feedback scheme, Ahlswede and Cai [16] determined the secrecy capacity of the physically degraded WTC-NF, and the secrecy capacity of the general WTC-NF has not been determined yet. On the basis of [16], Ardestanizadeh et al. investigated the WTC with rate limited feedback [17] where the legal receiver is free to use the noiseless feedback channel to send anything as he wishes (up to a rate  $R_f$ ). For the degraded case, they showed that the best choice of the legal receiver is sending a key through the feedback channel, and if the legal receiver’s channel output  $Y_1$  is sent, the best use of it is to extract a key. Later, Schaefer et al. [18] extended the work of [17] to a broadcast situation, where two legitimate receivers of the broadcast channel independently sent their secret keys to the transmitter via two noiseless feedback channels, and these keys help to increase the achievable secrecy rate region of the broadcast wiretap channel [7]. Cohen et al. [19] generalized Ardestanizadeh et al.’s work [17] by considering the WTC with noiseless feedback, and with causal channel state information (CSI) at both the transmitter and the legitimate receiver. Cohen et al. [19] showed that the transmitted message can be protected by two keys, where one is generated from the noiseless feedback, and the other is generated by the causal CSI. They further showed that these two keys increases the achievable secrecy rate

<sup>1</sup>The “physically degraded” indicates that the wiretapper’s received signal is a degraded version of the legal receiver’s.

of the WTC with rate limited feedback [17]. Other related works in the WTC with noiseless feedback and CSI are investigated in [20]-[21]. Here note that for the WTC-NF, the present literature ([16]-[21]) shows that the secrecy capacity is achieved only for the degraded case, i.e., Ahlswede and Cai's secret key based feedback coding scheme [16] is only optimal for the degraded channel models. Finding the optimal feedback coding scheme for the general channel models needs us to exploit other uses of the feedback.

The broadcast channel with mutual secrecy requirement (BC-MSR) is an important model for the PLS in the down-link of the wireless communication systems. The already existing literature [12], [13] provides inner and outer bounds on the secrecy capacity region of BC-MSR. To investigate the feedback effects on the BC-MSR (see Figure 1), in this paper, two feedback strategies for the BC-MSR are proposed. One is an extension of the already existing secret key based feedback scheme for the WTC [16], and the other is a hybrid coding scheme using the feedback to generate not only keys but also cooperative messages helping the receivers to improve their decoding performance. Two inner bounds on the secrecy capacity region of the feedback model shown in Figure 1 are constructed with respect to the proposed two feedback coding schemes. Moreover, for comparison, we also provide a corresponding outer bound. These inner and outer bounds are further illustrated via two examples (a Dueck type example and a Blackwell type example).

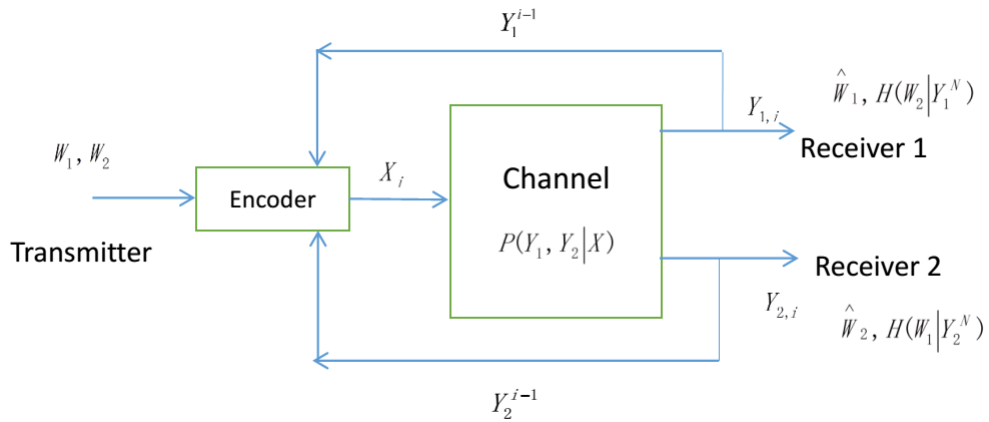

Fig. 1: The broadcast channel with noiseless feedback and mutual secrecy requirement

Now the remainder of this paper is organized as follows. Necessary mathematical background, the previous non-feedback coding scheme for the BC-MSR and a generalized Wyner-Ziv coding scheme are provided in Section II. Section III is for the model formulation and the main results.

Section IV shows the details about the proof of the main results. Two examples and numerical results are shown in Section V, and a summary of this work is given in Section VI.

## II. PRELIMINARIES

### A. Notations and Basic Lemmas

*Notations:* For the rest of this paper, the random variables (RVs), values and alphabets are written in uppercase letters, lowercase letters and calligraphic letters, respectively. The random vectors and their values are denoted by a similar convention. For example,  $Y_1$  represents a RV, and  $y_1$  represents a value in  $\mathcal{Y}_1$ . Similarly,  $Y_1^N$  represents a random  $N$ -vector  $(Y_{1,1}, \dots, Y_{1,N})$ , and  $y_1^N = (y_{1,1}, \dots, y_{1,N})$  represents a vector value in  $\mathcal{Y}_1^N$  (the  $N$ -th Cartesian power of  $\mathcal{Y}_1$ ). In addition, for an event  $X = x$ , its probability is denoted by  $P(x)$ . In the remainder of this paper, the base of the log function is 2.

An independent identically distributed (i.i.d.) generated vector  $x^N$  according to the probability  $P(x)$  is  $\epsilon$ -typical if for all  $x \in \mathcal{X}$ ,

$$\left| \frac{\pi_{x^N}(x)}{N} - P(x) \right| \leq \epsilon,$$

where  $\pi_{x^N}(x)$  is the number of  $x$  showing up in  $x^N$ . The set composed of all typical vectors  $x^N$  is called the strong typical set, and it is denoted by  $T_\epsilon^N(P(x))$ . The following lemmas related with  $T_\epsilon^N(P(x))$  will be used in the rest of this paper.

**Lemma 1: (Covering Lemma [23]):** Let  $X^N$  and  $Y^N(l)$  ( $l \in \mathcal{L}$  and  $|\mathcal{L}| \geq 2^{NR}$ ) be i.i.d. generated random vectors with respect to (w.r.t.) the probabilities  $P(x)$  and  $P(y)$ , respectively. Here notice that  $X^N$  is independent of  $Y^N(l)$ . Then there exists  $\nu > 0$  satisfying the condition that

$$\lim_{N \rightarrow \infty} P(\forall l \in \mathcal{L}, (X^N, Y^N(l)) \notin T_\nu^N(P(x, y))) = 0$$

if  $R > I(X; Y) + \varphi(\nu)$ , where  $\varphi(\nu) \rightarrow 0$  as  $\nu \rightarrow 0$ .

**Lemma 2: (Packing Lemma [23]):** Let  $X^N$  and  $Y^N(l)$  ( $l \in \mathcal{L}$  and  $|\mathcal{L}| \leq 2^{NR}$ ) be i.i.d. generated random vectors w.r.t. the probabilities  $P(x)$  and  $P(y)$ , respectively. Here notice that  $X^N$  is independent of  $Y^N(l)$ . Then there exists  $\nu > 0$  satisfying the condition that

$$\lim_{N \rightarrow \infty} P(\exists l \in \mathcal{L} \text{ s.t. } (X^N, Y^N(l)) \in T_\nu^N(P(x, y))) = 0$$

if  $R < I(X; Y) - \varphi(\nu)$ , where  $\varphi(\nu) \rightarrow 0$  as  $\nu \rightarrow 0$ .

**Lemma 3: (Balanced coloring lemma [16, p. 260]):** For any  $\epsilon, \delta > 0$  and sufficiently large  $N$ , let  $Q^N, U_1^N, U_2^N, V_2^N, Y_1^N$  and  $Y_2^N$  be i.i.d. generated random vectors respectively w.r.t. the probabilities  $P(q), P(u_1), P(u_2), P(v_2), P(y_1)$  and  $P(y_2)$ . Given  $y_2^N, P(q), P(u_1), P(u_2)$  and  $P(v_2)$ , let  $T_{P(y_1|y_2,q,u_1,u_2,v_2)}^N(y_2^N, q^N, u_1^N, u_2^N, v_2^N)$  be the conditional strong typical set composed of all  $y_1^N$  satisfying the fact that  $(y_1^N, y_2^N, q^N, u_1^N, u_2^N, v_2^N)$  are jointly typical. In addition, for  $\gamma < |T_{P(y_1|y_2,q,u_1,u_2,v_2)}^N(y_2^N, q^N, u_1^N, u_2^N, v_2^N)|$ , let  $\phi$  be a  $\gamma$ -coloring

$$\phi : T_\epsilon^N(P(y_1)) \rightarrow \{1, 2, \dots, \gamma\},$$

and  $\phi^{-1}(k)$  ( $k \in \{1, 2, \dots, \gamma\}$ ) be a set composed of all  $y_1^N$  such that  $\phi(y_1^N) = k$  and  $y_1^N \in T_{P(y_1|y_2,q,u_1,u_2,v_2)}^N(y_2^N, q^N, u_1^N, u_2^N, v_2^N)$ . Then we have

$$|\phi^{-1}(k)| \leq \frac{|T_{P(y_1|y_2,q,u_1,u_2,v_2)}^N(y_2^N, q^N, u_1^N, u_2^N, v_2^N)|(1 + \delta)}{\gamma}, \quad (2.1)$$

where  $k \in \{1, 2, \dots, \gamma\}$ .

*Remark 1:* From Lemma 3, it is easy to see that there are at least

$$\frac{|T_{P(y_1|y_2,q,u_1,u_2,v_2)}^N(y_2^N, q^N, u_1^N, u_2^N, v_2^N)|}{\frac{|T_{P(y_1|y_2,q,u_1,u_2,v_2)}^N(y_2^N, q^N, u_1^N, u_2^N, v_2^N)|(1 + \delta)}{\gamma}} = \frac{\gamma}{1 + \delta} \quad (2.2)$$

colors and at most  $\gamma$  colors mapped by  $T_{P(y_1|y_2,q,u_1,u_2,v_2)}^N(y_2^N, q^N, u_1^N, u_2^N, v_2^N)$ . Letting  $\gamma = |T_{P(y_1|y_2,q,u_1,u_2,v_2)}^N(y_2^N, q^N, u_1^N, u_2^N, v_2^N)|$  and applying the properties of the conditional strong typical set [23], we see that

$$\gamma = |T_{P(y_1|y_2,q,u_1,u_2,v_2)}^N(y_2^N, q^N, u_1^N, u_2^N, v_2^N)| \geq (1 - \epsilon_1)2^{N(1-\epsilon_2)H(Y_1|Y_2,Q,U_1,U_2,V_2)}, \quad (2.3)$$

where  $\epsilon_1$  and  $\epsilon_2$  tend to zero while  $N \rightarrow \infty$ .

### B. Non-feedback coding scheme for the BC-MSR

For the model of Figure 1 without feedback, a hybrid coding scheme combining Marton's binning technique for the general broadcast channel [22] with the random binning technique for the wiretap channel [1] is proposed in [12], [13]. In this subsection, we review this hybrid coding scheme.

*Definitions:*

The message  $W_j$  ( $j = 1, 2$ ) is conveyed to Receiver  $j$ , and it is uniformly drawn from the set  $\{1, \dots, 2^{NR_j}\}$ . The randomly generated  $W'_j$ , which is used for confusing the illegal receiver <sup>2</sup>, is

<sup>2</sup>The idea of using random messages to confuse the wiretapper is exactly the same as the random binning technique used in Wyner's wiretap channel [1], where this randomly produced message is analogous to the randomly chosen bin index used in the random binning scheme.

uniformly drawn from the set  $\{1, \dots, 2^{NR'_j}\}$ , i.e.,  $Pr\{W'_j = i\} = 2^{-NR'_j}$ , where  $i \in \{1, \dots, 2^{NR'_j}\}$ . Moreover, similar to the coding scheme in Marton's achievable region for the broadcast channel [22], the message  $W''_j$ , which enables its codeword  $U_j^N$  to be jointly typical with other codewords, chooses values from the set  $\{1, \dots, 2^{NR''_j}\}$ .

*Code construction:*

First, randomly generate  $2^{NR_0}$  i.i.d.  $Q^N$  w.r.t.  $P(q)$ , and label them as  $q^N(w_0)$ , where  $w_0 \in \{1, 2, \dots, 2^{NR_0}\}$ . Then, for each possible value of  $q^N$ , randomly generate  $2^{N(R_j+R'_j+R''_j)}$  i.i.d.  $U_j^N$  w.r.t.  $P(u_j|q)$ , and label them as  $u_j^N(w_j, w'_j, w''_j)$ , where  $w_j \in \{1, 2, \dots, 2^{NR_j}\}$ ,  $w'_j \in \{1, 2, \dots, 2^{NR'_j}\}$  and  $w''_j \in \{1, 2, \dots, 2^{NR''_j}\}$ . Finally, for each possible value of  $q^N$ ,  $u_1^N$  and  $u_2^N$ , the channel input  $x^N$  is i.i.d. generated w.r.t.  $P(x|q, u_1, u_2)$ .

*Encoding procedure:*

The transmitter selects  $q^N(w_0)$ ,  $u_1^N(w_1, w'_1, w''_1)$  and  $u_2^N(w_2, w'_2, w''_2)$  to transmit. Here notice that  $w_0$ ,  $w'_1$  and  $w'_2$  are randomly chosen from the sets  $\{1, 2, \dots, 2^{NR_0}\}$ ,  $\{1, 2, \dots, 2^{NR'_1}\}$  and  $\{1, 2, \dots, 2^{NR'_2}\}$ , respectively, and the indexes  $w''_1$  and  $w''_2$  are chosen by finding a pair of  $(u_1^N(w_1, w'_1, w''_1), u_2^N(w_2, w'_2, w''_2))$  satisfying the condition that given  $q^N(w_0)$ ,  $(u_1^N, u_2^N, q^N(w_0))$  are jointly typical. If multiple pairs exist, choose the pair with the smallest indexes; if no such pair exists, proclaim an encoding error. On the basis of the covering lemma (see Lemma 1), this kind of encoding error tends to zero if

$$R''_1 + R''_2 \geq I(U_1; U_2|Q). \quad (2.4)$$

*Decoding procedure:*

First, Receiver  $j$  ( $j = 1, 2$ ) chooses a unique  $q^N$  jointly typical with  $y_j^N$ . if more than one or no such  $q^N$  exists, declare an decoding error. From packing lemma (see Lemma 2), this kind of decoding error tends to zero if

$$R_0 \leq I(Y_j; Q). \quad (2.5)$$

After decoding  $q^N$ , Receiver  $j$  seeks a unique  $u_j^N$  satisfying the condition that  $(u_j^N, q^N, y_j^N)$  are jointly typical. From the packing lemma, this kind of decoding error tends to zero if

$$R_j + R'_j + R''_j \leq I(Y_j; U_j|Q). \quad (2.6)$$

Once  $u_j^N$  is decoded, Receiver  $j$  extracts  $w_j$  in it.

*Equivocation analysis:*

The Receiver 2's equivocation rate  $\Delta_1$ , which is denoted by  $\Delta_1 = \frac{1}{N}H(W_1|Y_2^N)$ , follows that

$$\begin{aligned}
\Delta_1 &= \frac{1}{N}H(W_1|Y_2^N) \geq \frac{1}{N}H(W_1|Y_2^N, Q^N, U_2^N) \\
&= \frac{1}{N}(H(W_1, Y_2^N, Q^N, U_2^N) - H(Y_2^N, Q^N, U_2^N)) \\
&= \frac{1}{N}(H(U_1^N, W_1, Y_2^N, Q^N, U_2^N) - H(U_1^N|W_1, Y_2^N, Q^N, U_2^N) - H(Y_2^N, Q^N, U_2^N)) \\
&\stackrel{(a)}{=} \frac{1}{N}(H(Y_2^N|Q^N, U_2^N, U_1^N) + H(U_1^N|Q^N, U_2^N) - H(U_1^N|W_1, Y_2^N, Q^N, U_2^N) - H(Y_2^N|Q^N, U_2^N)) \\
&= \frac{1}{N}(H(U_1^N|Q^N) - I(U_1^N; U_2^N|Q^N) - H(U_1^N|W_1, Y_2^N, Q^N, U_2^N) - I(Y_2^N; U_1^N|Q^N, U_2^N)) \\
&\stackrel{(b)}{=} \frac{1}{N}(N(R_1 + R'_1 + R''_1) - NI(U_1; U_2|Q) - NI(Y_2; U_1|Q, U_2) - H(U_1^N|W_1, Y_2^N, Q^N, U_2^N)) \\
&\stackrel{(c)}{\geq} R_1 + R'_1 + R''_1 - I(U_1; U_2|Q) - I(Y_2; U_1|Q, U_2) - \delta(\epsilon_1), \tag{2.7}
\end{aligned}$$

where (a) follows from  $H(W_1|U_1^N) = 0$ , (b) follows from the generation of  $Q^n, U_1^n, U_2^n$  and the channel is memoryless, and (c) follows from that given  $\tilde{w}_1, q^N, u_2^N$  and  $y_2^n$ , Receiver 2 tries to find out only one  $u_1^n$  that is jointly typical with  $y_2^n, q^n, u_2^n$ , and implied by the packing lemma, we see that Receiver 2's decoding error tends to zero if

$$R_1 + R'_1 \leq I(Y_2; U_1|Q, U_2), \tag{2.8}$$

then applying Fano's lemma,  $\frac{1}{N}H(U_1^N|W_1, Y_2^N, Q^N, U_2^N) \leq \epsilon_1$  is obtained, where  $\epsilon_1 \rightarrow 0$  while  $N \rightarrow \infty$ . From (2.7), we can conclude that  $\Delta_1 \geq R_1 - \epsilon$  if

$$R'_1 + R''_1 \geq I(U_1; U_2|Q) + I(Y_2; U_1|Q, U_2). \tag{2.9}$$

Analogously, we can conclude that  $\Delta_2 \geq R_2 - \epsilon$  if

$$R'_2 + R''_2 \geq I(U_1; U_2|Q) + I(Y_1; U_2|Q, U_1), \tag{2.10}$$

and

$$R_2 + R'_2 \leq I(Y_1; U_2|Q, U_1). \tag{2.11}$$

From (2.4), (2.6), (2.8), (2.9), (2.10) and (2.11), the achievable secrecy rate region  $\mathcal{C}_{bc-msr}$  for the BC-MSR [12] is obtained, and it is given by

$$\begin{aligned}
\mathcal{C}_{bc-msr} &= \{(R_1, R_2) : 0 \leq R_1 \leq I(Y_1; U_1|Q) - I(U_1; U_2|Q) - I(Y_2; U_1|Q, U_2) \\
&0 \leq R_2 \leq I(Y_2; U_2|Q) - I(U_1; U_2|Q) - I(Y_1; U_2|Q, U_1)\}.
\end{aligned}$$

Combining the above coding scheme for  $\mathcal{C}_{bc-msr}$  with the already existing secret key based feedback scheme for the WTC [16], it is not difficult to propose a secret key based feedback coding scheme for the BC-MSR, which will be shown in the next section.

### C. The Generalized Wyner-Ziv Coding Scheme for the Distributed Source Coding with Side Information

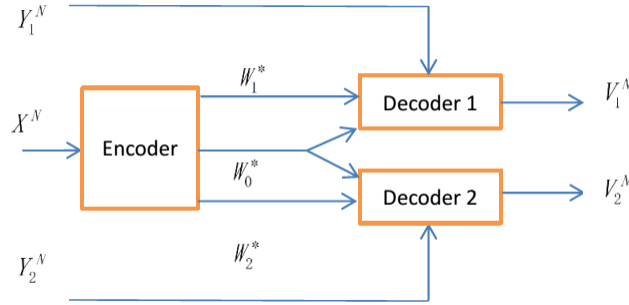

Fig. 2: The distributed source coding with side information

In this subsection, we review the generalized Wyner-Ziv coding scheme for the distributed source coding with side information [24]. For the distributed source coding with side information shown in Figure 2, the source  $X^N$  is correlated with the side information  $Y_1^N$  and  $Y_2^N$ , and they are i.i.d. generated according to the probability  $P(x, y_1, y_2)$ . Using an encoding function  $\phi : \mathcal{X}^N \rightarrow \{1, 2, \dots, 2^{NR_0}\} \times \{1, 2, \dots, 2^{NR_1}\} \times \{1, 2, \dots, 2^{NR_2}\}$ , the transmitter compresses  $X^N$  into three indexes  $W_0^*$ ,  $W_1^*$  and  $W_2^*$  respectively choosing values from the sets  $\{1, 2, \dots, 2^{NR_0}\}$ ,  $\{1, 2, \dots, 2^{NR_1}\}$  and  $\{1, 2, \dots, 2^{NR_2}\}$ . The indexes  $W_0^*$ ,  $W_j^*$  ( $j = 1, 2$ ) together with the side information  $Y_j^N$  are available at Receiver  $j$ . Receiver  $j$  generates a reconstruction sequence  $\hat{V}_j^N = \varphi(W_0^*, W_j^*, Y_j^N)$  by applying a reconstruction function  $\varphi_j : \{1, 2, \dots, 2^{NR_0}\} \times \{1, 2, \dots, 2^{NR_j}\} \times \mathcal{Y}_j^N \rightarrow \mathcal{V}_j^N$  to the indexes  $W_0^*$ ,  $W_j^*$  and the side information  $Y_j^N$ . The goal of the communication is that the reconstruction sequence  $\hat{V}_j^N$  is jointly typical with the source  $X^N$  according to the probability  $P(v_j|x) \times P(x)$ .

A rate triplet  $(R_0, R_1, R_2)$  is said to be achievable if for any  $\epsilon > 0$ , there exists a sequence of encoding and reconstruction functions  $(\phi, \varphi_1, \varphi_2)$  such that

$$Pr\{(X^N, \hat{V}_j^N) \notin T_\epsilon^N(P(x, v_j))\} \rightarrow 0 \quad (2.12)$$



as  $N \rightarrow \infty$ . The following generalized Wyner-Ziv Theorem [24] provides an achievable region  $\mathcal{R}_{inner}$  consisting of achievable rate triplets  $(R_0, R_1, R_2)$  for this distributed source coding with side information problem.

*Theorem 1: (Generalized Wyner-Ziv Theorem):* For the distributed source coding with side information, an achievable rate region  $\mathcal{R}_{inner}$  is given by

$$\begin{aligned} \mathcal{R}_{inner} &= \{(R_0, R_1, R_2) : R_0 + R_1 \geq I(X; V_0, V_1 | Y_1) \\ R_0 + R_2 &\geq I(X; V_0, V_2 | Y_2) \\ R_0 + R_1 + R_2 &\geq I(X; V_1 | Y_1, V_0) + I(X; V_2 | Y_2, V_0) + \max_{j \in \{1, 2\}} I(X; V_0 | Y_j)\}, \end{aligned} \quad (2.13)$$

where  $(V_0, V_1, V_2) \rightarrow X \rightarrow (Y_1, Y_2)$ .

*Achievable coding scheme for Theorem 1:*

- **Definitions:** The index  $w_0^*$  chooses values from the set  $\{1, 2, \dots, 2^{NR_0}\}$ , and divide  $w_0^*$  into three sub-indexes  $w_{0,0}^*$ ,  $w_{0,1}^*$  and  $w_{0,2}^*$ , where each sub-index  $w_{0,i}^*$  ( $i \in \{0, 1, 2\}$ ) chooses values from the set  $\{1, 2, \dots, 2^{NR_{0,i}}\}$  and  $R_{0,0} + R_{0,1} + R_{0,2} = R_0$ . The index  $w_1^*$  chooses values from  $\{1, 2, \dots, 2^{NR_1}\}$ , and divide  $w_1^*$  into two sub-indexes  $w_{1,0}^*$  and  $w_{1,1}^*$ , where each sub-index  $w_{1,j}^*$  ( $j \in \{0, 1\}$ ) chooses values from  $\{1, 2, \dots, 2^{NR_{1,j}}\}$  and  $R_{1,0} + R_{1,1} = R_1$ . Similarly, the index  $w_2^*$  chooses values from  $\{1, 2, \dots, 2^{NR_2}\}$ , and divide  $w_2^*$  into two sub-indexes  $w_{2,0}^*$  and  $w_{2,2}^*$ , where each sub-index  $w_{2,l}^*$  ( $l \in \{0, 2\}$ ) chooses values from  $\{1, 2, \dots, 2^{NR_{2,l}}\}$  and  $R_{2,0} + R_{2,2} = R_2$ . Define  $k_{1,0}$ ,  $k_{2,0}$ ,  $k_1$  and  $k_2$  as auxiliary indexes respectively taking values in  $\{1, 2, \dots, 2^{N(R'_0 - R_{1,0})}\}$ ,  $\{1, 2, \dots, 2^{N(R'_0 - R_{2,0})}\}$ ,  $\{1, 2, \dots, 2^{NR'_1}\}$  and  $\{1, 2, \dots, 2^{NR'_2}\}$ .
- **Code-book generation:** There are two different ways to generate the sequence  $v_0^N$ . The first way is to generate  $2^{N(R_{0,0} + R'_0)}$  i.i.d. sequences  $v_0^N(1; w_{0,0}^*, w_{1,0}^*, k_{1,0})$  with respect to (w.r.t.) the probability  $P(v_0)$ . The second way is to generate  $2^{N(R_{0,0} + R'_0)}$  i.i.d. sequences  $v_0^N(2; w_{0,0}^*, w_{2,0}^*, k_{2,0})$  w.r.t. the probability  $P(v_0)$ . Here note that  $v_0^N(j; w_{0,0}^*, w_{j,0}^*, k_{j,0})$  ( $j \in \{1, 2\}$ ) is intended to be decoded by Receiver  $j$ . Then, generate  $2^{N(R_{0,1} + R_{1,1} + R'_1)}$  i.i.d. sequences  $v_1^N(w_{0,1}^*, w_{1,1}^*, k_1)$  w.r.t. the probability  $P(v_1)$ , and generate  $2^{N(R_{0,2} + R_{2,2} + R'_2)}$  i.i.d. sequences  $v_2^N(w_{0,2}^*, w_{2,2}^*, k_2)$  w.r.t. the probability  $P(v_2)$ .
- **Encoding:** Given a source  $x^N$ , the encoder seeks a pair of sequences  $(v_0^N(j; \tilde{w}_{0,0}^*, \tilde{w}_{j,0}^*, \tilde{k}_{j,0}), v_j^N(\tilde{w}_{0,j}^*, \tilde{w}_{j,j}^*, \tilde{k}_j))$  ( $j \in \{1, 2\}$ ) satisfying the condition that  $(x^N, v_0^N(j; \tilde{w}_{0,0}^*, \tilde{w}_{j,0}^*, \tilde{k}_{j,0}), v_j^N(\tilde{w}_{0,j}^*, \tilde{w}_{j,j}^*, \tilde{k}_j))$  are jointly typical. If there is more than one such pair, randomly choose one. If there is

no such pair, declare an encoding error. On the basis of the covering lemma (see 1), the encoding error tends to zero if

$$R'_0 + R_{0,0} \geq I(X; V_0), \quad (2.14)$$

and

$$R'_j + R_{0,j} + R_{j,j} \geq I(V_j; X, V_0). \quad (2.15)$$

Once the sequences  $v_0^N(j; \tilde{w}_{0,0}^*, \tilde{w}_{j,0}^*, \tilde{k}_{j,0})$  and  $v_j^N(\tilde{w}_{0,j}^*, \tilde{w}_{j,j}^*, \tilde{k}_j)$  are chosen for  $j \in \{1, 2\}$ , the encoder sends the index  $w_0^* = (\tilde{w}_{0,0}^*, \tilde{w}_{0,1}^*, \tilde{w}_{0,2}^*)$  to both receivers, sends  $w_1^* = (\tilde{w}_{1,0}^*, \tilde{w}_{1,1}^*)$  to Receiver 1 only, and sends  $w_2^* = (\tilde{w}_{2,0}^*, \tilde{w}_{2,2}^*)$  to Receiver 2 only.

- **Decoding:** Upon receiving the indexes  $w_0^*$  and  $w_j^*$  ( $j \in \{1, 2\}$ ), Receiver  $j$  parses the common index  $w_0^*$  as  $(\tilde{w}_{0,0}^*, \tilde{w}_{0,1}^*, \tilde{w}_{0,2}^*)$ , and its private index  $w_j^*$  as  $(\tilde{w}_{j,0}^*, \tilde{w}_{j,j}^*)$ . Then given the side information  $y_j^N$  and  $\tilde{w}_{0,0}^*, \tilde{w}_{0,1}^*, \tilde{w}_{0,2}^*, \tilde{w}_{j,0}^*, \tilde{w}_{j,j}^*$ , Receiver  $j$  seeks a unique pair of  $(v_0^N(j; \tilde{w}_{0,0}^*, \tilde{w}_{j,0}^*, \hat{k}_{j,0}), v_j^N(\tilde{w}_{0,j}^*, \tilde{w}_{j,j}^*, \hat{k}_j))$  satisfying the condition that  $(v_0^N(j; \tilde{w}_{0,0}^*, \tilde{w}_{j,0}^*, \hat{k}_{j,0}), v_j^N(\tilde{w}_{0,j}^*, \tilde{w}_{j,j}^*, \hat{k}_j), y_j^N)$  are jointly typical. If there is no or more than one pair, declare an decoding error. On the basis of the packing lemma (see 2), Receiver  $j$ 's decoding error tends to zero if

$$R'_j \leq I(V_j; V_0, Y_j), \quad (2.16)$$

and

$$R'_0 - R_{j,0} + R'_j \leq I(V_0; Y_j) + I(V_j; V_0, Y_j). \quad (2.17)$$

Once Receiver  $j$  finds such unique pair of  $(v_0^N(j; \tilde{w}_{0,0}^*, \tilde{w}_{j,0}^*, \hat{k}_{j,0}), v_j^N(\tilde{w}_{0,j}^*, \tilde{w}_{j,j}^*, \hat{k}_j))$ , he generates the re-construction sequence  $\hat{V}_j^N = v_j^N(\tilde{w}_{0,j}^*, \tilde{w}_{j,j}^*, \hat{k}_j)$ .

- Using the fact that  $R_{0,0} + R_{0,1} + R_{0,2} = R_0$ ,  $R_{1,0} + R_{1,1} = R_1$ ,  $R_{2,0} + R_{2,2} = R_2$ , and applying Fourier-Motzkin elimination to remove  $R'_0$ ,  $R'_1$  and  $R'_2$  from (2.14), (2.15), (2.16) and (2.17), Theorem 1 is proved.

Here note that the generalized Wyner-Ziv coding scheme described above indicates that in a broadcast channel, each receiver's channel output can be viewed as side information helping the receiver to decode an estimation of the channel input, and this estimation of the channel input helps the receiver to improve his decoding performance. Motivated by this generalized Wyner-Ziv coding scheme, in the next section, a hybrid feedback strategy for the BC-MSR is proposed, which combines the already existing secret key based feedback scheme for the WTC [16] and

the generalized Wyner-Ziv coding scheme with the previous non-feedback coding scheme for the BC-MSR described in Subsection II-B.

### III. PROBLEM FORMULATION AND MAIN RESULTS

The model of BC-MSR consists of one input  $x^N$ , two outputs  $y_1^N, y_2^N$ , and satisfies

$$P(y_1^N, y_2^N | x^N) = \prod_{i=1}^n P(y_{1,i}, y_{2,i} | x_i), \quad (3.1)$$

where  $x_i \in \mathcal{X}$ ,  $y_{1,i} \in \mathcal{Y}_1$  and  $y_{2,i} \in \mathcal{Y}_2$ .

Let  $W_1$  and  $W_2$  be the transmission messages, and their values respectively belong to the alphabets  $\mathcal{W}_1 = \{1, 2, \dots, M_1\}$  and  $\mathcal{W}_2 = \{1, 2, \dots, M_2\}$ . In addition,  $Pr\{W_1 = i\} = \frac{1}{M_1}$  for  $i \in \mathcal{W}_1$ , and  $Pr\{W_2 = j\} = \frac{1}{M_2}$  for  $j \in \mathcal{W}_2$ . Using feedback, the transmitter produces the time- $t$  channel input  $X_t$  as a function of the messages  $W_1, W_2$  and of the previously received channel outputs  $Y_{1,1}, \dots, Y_{1,t-1}$  and  $Y_{2,1}, \dots, Y_{2,t-1}$ , i.e.,

$$X_t = f_t(W_1, W_2, Y_1^{t-1}, Y_2^{t-1}) \quad (3.2)$$

for some stochastic encoding function  $f_t$  ( $1 \leq t \leq N$ ).

After  $N$  channel uses, Receiver  $j$  ( $j = 1, 2$ ) decodes  $W_j$ . Namely, Receiver  $j$  generates the guess

$$\hat{W}_j = \psi_j(Y_j^N),$$

where  $\psi_j$  is Receiver  $j$ 's decoding function. Receiver  $j$ 's average decoding error probability is denoted by

$$P_{e,j} = \frac{1}{M_j} \sum_{w_j \in \mathcal{W}_j} Pr\{\psi_j(y_j^N) \neq w_j | w_j \text{ sent}\}. \quad (3.3)$$

Receiver 2's equivocation rate of the message  $W_1$  is formulated as

$$\Delta_1 = \frac{1}{N} H(W_1 | Y_2^N). \quad (3.4)$$

Analogously, Receiver 1's equivocation rate of the message  $W_2$  is formulated as

$$\Delta_2 = \frac{1}{N} H(W_2 | Y_1^N). \quad (3.5)$$

Define an achievable secrecy rate pair  $(R_1, R_2)$  as below. Given two positive numbers  $R_1$  and  $R_2$ , if for arbitrarily small  $\epsilon$ , there exist one channel encoder and two channel decoders with parameters  $M_1, M_2, N, \Delta_1, \Delta_2, P_{e,1}$  and  $P_{e,2}$  satisfying

$$\frac{\log M_1}{N} \geq R_1 - \epsilon, \quad (3.6)$$

$$\frac{\log M_2}{N} \geq R_2 - \epsilon, \quad (3.7)$$

$$\Delta_1 \geq R_1 - \epsilon, \quad (3.8)$$

$$\Delta_2 \geq R_2 - \epsilon, \quad (3.9)$$

$$P_{e,1} \leq \epsilon, P_{e,2} \leq \epsilon, \quad (3.10)$$

the pair  $(R_1, R_2)$  is called an achievable secrecy rate pair. The secrecy capacity region  $\mathcal{C}_s^f$  consists of all achievable secrecy rate pairs. We first propose a hybrid inner bound  $\mathcal{C}_s^{f-in-2}$  on  $\mathcal{C}_s^f$ . The feedback channel outputs  $Y_1^{i-1}$  and  $Y_2^{i-1}$  are not only used to generate secret keys protecting part of the messages, but also used to produce cooperative messages represented by  $V_0, V_1$  and  $V_2$  helping the receivers to improve their decoding performances. The inner bound  $\mathcal{C}_s^{f-in-2}$  is provided in the following Theorem 2.

*Theorem 2:*  $\mathcal{C}_s^{f-in-2} \subseteq \mathcal{C}_s^f$ , where

$$\begin{aligned} \mathcal{C}_s^{f-in-2} = \{ & (R_1, R_2) : 0 \leq R_1 \leq \min\{[I(U_1; Y_1, V_1|Q) - I(U_1; U_2|Q) - I(U_1; Y_2, V_2|Q, U_2)]^+ \\ & + H(Y_1|Q, U_1, U_2, Y_2, V_2), I(U_1; Y_1, V_1|Q)\}, \\ & 0 \leq R_2 \leq \min\{[I(U_2; Y_2, V_2|Q) - I(U_1; U_2|Q) - I(U_2; Y_1, V_1|Q, U_1)]^+ + H(Y_2|Q, U_1, U_2, Y_1, V_1), \\ & I(U_2; Y_2, V_2|Q)\}, \\ & 0 \leq R_1 \leq \min\{I(Q; Y_1, V_1), I(Q; Y_2, V_2)\} + I(U_1; Y_1, V_1|Q) - I(V_0, V_1; Q, U_1, U_2, \tilde{Y}|Y_1), \\ & 0 \leq R_2 \leq \min\{I(Q; Y_1, V_1), I(Q; Y_2, V_2)\} + I(U_2; Y_2, V_2|Q) - I(V_0, V_2; Q, U_1, U_2, \tilde{Y}|Y_2), \\ & 0 \leq R_1 + R_2 \leq \min\{I(Q; Y_1, V_1), I(Q; Y_2, V_2)\} + I(U_1; Y_1, V_1|Q) + I(U_2; Y_2, V_2|Q) \\ & - I(U_1; U_2|Q) - I(V_1; Q, U_1, U_2, \tilde{Y}|Y_1, V_0) - I(V_2; Q, U_1, U_2, \tilde{Y}|Y_2, V_0) - \\ & \max\{I(V_0; Q, U_1, U_2, \tilde{Y}|Y_1), I(V_0; Q, U_1, U_2, \tilde{Y}|Y_2)\}, \end{aligned}$$

$\tilde{Y} = (Y_1, Y_2)$  and the joint distribution is denoted by

$$\begin{aligned} & P(q, u_1, u_2, v_0, v_1, v_2, x, y_1, y_2) \\ & = P(v_0, v_1, v_2|q, u_1, u_2, y_1, y_2)P(y_1, y_2|x)P(x|u_1, u_2)P(u_1, u_2|q)P(q). \end{aligned} \quad (3.11)$$

*Proof:* The coding scheme achieving the inner bound  $C_s^{f-in-2}$  combines the already existing secret key based feedback scheme for the WTC [16] and the previous non-feedback coding scheme for the BC-MSR with the generalized Wyner-Ziv scheme described in Section II, and it can be briefly illustrated as follows.

- *Encoding:* The transmission is through  $n$  blocks. First, similar to the secret key based feedback scheme for the WTC [16], in each block, split the transmitted message  $w_i$  ( $i \in \{1, 2\}$ ) into two parts, i.e.,  $w_i = (w_{i,1}, w_{i,2})$ . The sub-message  $w_{i,1}$  is encoded exactly the same as that in the non-feedback coding scheme for BC-MSR (see Section II), and  $w_{i,2}$  is encrypted by a key produced by the feedback channel output  $y_i^N$  of the previous block. Then, compress the encoded sequences  $u_1^N, u_2^N, q^N$  and the feedback channel outputs  $y_1^N$  and  $y_2^N$  from the previous block into three indexes  $w_0^*, w_1^*$  and  $w_2^*$ . Similar to the generalized Wyner-Ziv coding scheme introduced in Section II, we use the indexes  $w_0^*, w_1^*$  and  $w_2^*$  to generate  $v_1^N, v_2^N$  and  $v_0^N$ , where  $v_i^N$  ( $i \in \{1, 2\}$ ) is Receiver  $i$ 's estimation of the channel input, and  $v_0^N$  is an auxiliary sequence helping Receiver  $i$  to decode  $v_i^N$ . Finally, the sequence  $u_i^N$  ( $i \in \{1, 2\}$ ) for each block is chosen according to the current block's  $w_{i,1}$ , similar auxiliary messages  $w_i', w_i''$  shown in the non-feedback coding scheme for BC-MSR (see Section II), the encrypted  $w_{i,2}$  and the previous block's compressed index  $w_i^*$ . Moreover, the sequence  $q^N$  is chosen according to the current block's randomly chosen "common message"  $w_0$  (see the non-feedback coding scheme for BC-MSR in Section II) and the previous block's compressed index  $w_0^*$ . Here note that for the last block, we do not transmit the real message  $w_i$  ( $i \in \{1, 2\}$ ) to Receiver  $i$ , i.e., we transmit a constant in block  $n$ .
- *Decoding:* The decoding for Receiver  $i$  ( $i \in \{1, 2\}$ ) begins from the last block. In block  $n$ , using a similar decoding scheme of the non-feedback coding scheme for BC-MSR, Receiver  $i$  decodes  $u_i^N$  and  $q^N$  for block  $n$ . Then he extracts the block  $n - 1$ 's compressed indexes  $w_i^*$  and  $w_0^*$  from the decoded  $u_i^N$  and  $q^N$  of block  $n$ , respectively. Next, similar to the generalized Wyner-Ziv coding scheme, Receiver  $i$  views the received signal  $y_i^N$  of block  $n - 1$  as side information. Given block  $n - 1$ 's  $w_i^*, w_0^*$  and  $y_i^N$ , Receiver  $i$  seeks a unique pair of  $(v_i^N, v_0^N)$  in block  $n - 1$  satisfying the condition that  $(v_i^N, v_0^N, y_i^N)$  are jointly typical. Once  $v_i^N$  of block  $n - 1$  is decoded, Receiver  $i$  decodes  $q^N$  for block  $n - 1$  by finding a unique  $q^N$  satisfying the condition that  $(q^N, y_i^N, v_i^N)$  are jointly typical. After  $q^N$  for block  $n - 1$  is decoded, Receiver  $i$  decodes  $u_i^N$  for block  $n - 1$  by finding a unique  $u_i^N$  satisfying

the condition that  $(u_i^N, q^N, y_i^N, v_i^N)$  are jointly typical. Once Receiver  $i$  decodes  $u_i^N$  and  $q^N$  for block  $n - 1$ , he obtains the transmitted message  $w_i$  for block  $n - 1$  and extracts the block  $n - 2$ 's compressed indexes  $w_i^*$  and  $w_0^*$ . Repeating the above decoding procedure, Receiver  $i$  obtains all the messages.

Details about the proof are in Section IV. ■

Then, we propose a secret key based inner bound  $\mathcal{C}_s^{f-in-1}$  on  $\mathcal{C}_s^f$ , where the feedback is used to produce keys, and these keys together with the random binning technique prevent each receiver's intended message from being eavesdropped by the other receiver. The inner bound  $\mathcal{C}_s^{f-in-1}$  is shown in the following Theorem 3.

*Theorem 3:*  $\mathcal{C}_s^{f-in-1} \subseteq \mathcal{C}_s^f$ , where

$$\begin{aligned} \mathcal{C}_s^{f-in-1} = \{ & (R_1, R_2) : 0 \leq R_1 \leq [I(U_1; Y_1|Q) - I(U_1; U_2|Q) - I(U_1; Y_2|Q, U_2)]^+ + H(Y_1|Q, U_1, U_2, Y_2), \\ & 0 \leq R_2 \leq [I(U_2; Y_2|Q) - I(U_1; U_2|Q) - I(U_2; Y_1|Q, U_1)]^+ + H(Y_2|Q, U_1, U_2, Y_1), \\ & 0 \leq R_1 \leq I(U_1; Y_1|Q), \quad 0 \leq R_2 \leq I(U_2; Y_2|Q), \\ & 0 \leq R_1 + R_2 \leq \min\{I(Q; Y_1), I(Q; Y_2)\} + I(U_1; Y_1|Q) + I(U_2; Y_2|Q) - I(U_1; U_2|Q)\}, \end{aligned}$$

and the joint distribution is denoted by

$$P(q, u_1, u_2, x, y_1, y_2) = P(y_1, y_2|x)P(x|u_1, u_2)P(u_1, u_2|q)P(q), \quad (3.12)$$

which indicates the Markov condition  $Q \rightarrow (U_1, U_2) \rightarrow X \rightarrow (Y_1, Y_2)$ .

*Proof:* The coding scheme achieving the inner bound  $\mathcal{C}_s^{f-in-1}$  combines the already existing secret key based feedback scheme for the WTC [16] with the previous non-feedback coding scheme for the BC-MSR (see Section II). Letting  $V_0, V_1$  and  $V_2$  (the estimation of the channel input) of  $\mathcal{C}_s^{f-in-2}$  be constants,  $\mathcal{C}_s^{f-in-1}$  is directly obtained. Since the proof of  $\mathcal{C}_s^{f-in-1}$  is along the lines of the proof of  $\mathcal{C}_s^{f-in-2}$  without  $V_0, V_1$  and  $V_2$ , we omit the achievability proof of the inner bound  $\mathcal{C}_s^{f-in-1}$  here. ■

Finally, we propose an outer bound  $\mathcal{C}_s^{f-out}$  on  $\mathcal{C}_s^f$ , see the following Theorem 4.

*Theorem 4:*  $\mathcal{C}_s^f \subseteq \mathcal{C}_s^{f-out}$ , where

$$\begin{aligned} \mathcal{C}_s^{f-out} = \{ & (R_1, R_2) : 0 \leq R_1 \leq \min\{I(U_1; Y_1|Q) - I(U_1; Y_2|Q), I(U_1; Y_1|Q, U_2) - I(U_1; Y_2|Q, U_2), \\ & H(Y_1|Q, U_2, Y_2)\}, \\ & 0 \leq R_2 \leq \min\{I(U_2; Y_2|Q) - I(U_2; Y_1|Q), I(U_2; Y_2|Q, U_1) - I(U_2; Y_1|Q, U_1), H(Y_2|Q, U_1, Y_1)\}\}, \end{aligned}$$

the joint distribution is denoted by

$$P(q, u_1, u_2, x, y_1, y_2) = P(y_1, y_2|x)P(x|q, u_1, u_2)P(q, u_1, u_2), \quad (3.13)$$

and  $Q$  may be assumed to be a (deterministic) function of  $U_1$  and  $U_2$ .

*Proof:* See Appendix A. ■

#### IV. PROOF OF THEOREM 2

The messages are conveyed to the receivers via  $n$  blocks. In block  $i$  ( $1 \leq i \leq n$ ), the random sequences  $X^N, Y_1^N, Y_2^N, Q^N, U_1^N, U_2^N, V_0^N, V_1^N$  and  $V_2^N$  are denoted by  $\bar{X}_i, \bar{Y}_{1,i}, \bar{Y}_{2,i}, \bar{Q}_i, \bar{U}_{1,i}, \bar{U}_{2,i}, \bar{V}_{0,i}, \bar{V}_{1,i}$  and  $\bar{V}_{2,i}$ , respectively. In addition, let  $X^n = (\bar{X}_1, \dots, \bar{X}_n)$  be a collection of the random sequences  $X^N$  for all blocks. Similarly, define  $Y_1^n = (\bar{Y}_{1,1}, \dots, \bar{Y}_{1,n}), Y_2^n = (\bar{Y}_{2,1}, \dots, \bar{Y}_{2,n}), Q^n = (\bar{Q}_1, \dots, \bar{Q}_n), U_1^n = (\bar{U}_{1,1}, \dots, \bar{U}_{1,n}), U_2^n = (\bar{U}_{2,1}, \dots, \bar{U}_{2,n}), V_0^n = (\bar{V}_{0,1}, \dots, \bar{V}_{0,n}), V_1^n = (\bar{V}_{1,1}, \dots, \bar{V}_{1,n})$  and  $V_2^n = (\bar{V}_{2,1}, \dots, \bar{V}_{2,n})$ . The value of the random vector is written in lower case letter.

*Code-books generation:*

- The message  $W_j$  ( $j = 1, 2$ ) is sent to Receiver  $j$  via  $n$  blocks, i.e., the message  $W_j$  is composed of  $n$  components ( $W_j = (W_{j,1}, \dots, W_{j,n})$ ), and each component  $W_{j,i}$  ( $i \in \{1, 2, \dots, n\}$ ) is the message transmitted in block  $i$ . Here  $W_{j,i}$  takes values in the set  $\{1, \dots, 2^{NR_j}\}$ . Further divide  $W_{j,i}$  into two parts, i.e.,  $W_{j,i} = (W_{j,1,i}, W_{j,2,i})$ . The values of  $W_{j,1,i}$  and  $W_{j,2,i}$  respectively belong to the sets  $\{1, \dots, 2^{NR_{j1}}\}$  and  $\{1, \dots, 2^{NR_{j2}}\}$ . Here notice that  $R_{j1} + R_{j2} = R_j$ .
- In block  $i$  ( $1 \leq i \leq n$ ), randomly generate  $2^{N(R_0 + \tilde{R}_0)}$  i.i.d.  $\bar{Q}_i$  w.r.t.  $P(q)$ , and index them as  $\bar{q}_i(w_{0,i}, w_{0,0,i}^*, w_{0,1,i}^*, w_{0,2,i}^*)$ , where  $w_{0,i} \in \{1, 2, \dots, 2^{NR_0}\}$ ,  $w_{0,0,i}^* \in \{1, 2, \dots, 2^{N\tilde{R}_{00}}\}$ ,  $w_{0,1,i}^* \in \{1, 2, \dots, 2^{N\tilde{R}_{01}}\}$ ,  $w_{0,2,i}^* \in \{1, 2, \dots, 2^{N\tilde{R}_{02}}\}$ , and  $\tilde{R}_{00} + \tilde{R}_{01} + \tilde{R}_{02} = \tilde{R}_0$ .
- For each possible value of  $\bar{q}_i$ , randomly generate  $2^{N(R_1 + R'_1 + R''_1 + \tilde{R}_1)}$  i.i.d.  $\bar{U}_{1,i}$  w.r.t.  $P(u_1|q)$ , and index them as  $\bar{u}_{1,i}(w_{1,1,i}, w_{1,2,i}, w'_{1,i}, w''_{1,i}, w^*_{1,0,i}, w^*_{1,1,i})$ , where  $w_{1,1,i} \in \{1, 2, \dots, 2^{NR_{11}}\}$ ,  $w_{1,2,i} \in \{1, 2, \dots, 2^{NR_{12}}\}$ ,  $w'_{1,i} \in \{1, 2, \dots, 2^{NR'_1}\}$ ,  $w''_{1,i} \in \{1, 2, \dots, 2^{NR''_1}\}$ ,  $w^*_{1,0,i} \in \{1, 2, \dots, 2^{N\tilde{R}_{10}}\}$ ,  $w^*_{1,1,i} \in \{1, 2, \dots, 2^{N\tilde{R}_{11}}\}$ ,  $R_{11} + R_{12} = R_1$  and  $\tilde{R}_{10} + \tilde{R}_{11} = \tilde{R}_1$ .
- Analogously, for each possible value of  $\bar{q}_i$ , randomly generate  $2^{N(R_2 + R'_2 + R''_2 + \tilde{R}_2)}$  i.i.d.  $\bar{U}_{2,i}$  w.r.t.  $P(u_2|q)$ , and index them as  $\bar{u}_{2,i}(w_{2,1,i}, w_{2,2,i}, w'_{2,i}, w''_{2,i}, w^*_{2,0,i}, w^*_{2,2,i})$ , where  $w_{2,1,i} \in \{1, 2, \dots, 2^{NR_{21}}\}$ ,  $w_{2,2,i} \in \{1, 2, \dots, 2^{NR_{22}}\}$ ,  $w'_{2,i} \in \{1, 2, \dots, 2^{NR'_2}\}$ ,  $w''_{2,i} \in \{1, 2, \dots, 2^{NR''_2}\}$ ,  $w^*_{2,0,i} \in \{1, 2, \dots, 2^{N\tilde{R}_{20}}\}$ ,  $w^*_{2,2,i} \in \{1, 2, \dots, 2^{N\tilde{R}_{22}}\}$ ,  $R_{21} + R_{22} = R_2$  and  $\tilde{R}_{20} + \tilde{R}_{22} = \tilde{R}_2$ .

- In block  $i$ , for each possible values of  $\bar{q}_i$ ,  $\bar{u}_{1,i}$  and  $\bar{u}_{2,i}$ , the channel input  $\tilde{X}_i$  is i.i.d. generated w.r.t.  $P(x|q, u_1, u_2)$ .
- For each possible value of  $\bar{q}_i$ ,  $\bar{u}_{1,i}$ ,  $\bar{u}_{2,i}$ ,  $\bar{y}_{1,i}$  and  $\bar{y}_{2,i}$ , produce  $\bar{V}_{0,i}$  in two ways:
  - 1) Produce  $2^{N(\tilde{R}_{00}+\tilde{R}'_0)}$  i.i.d.  $\bar{V}_{0,i}$  w.r.t.  $P(v_0|q, u_1, u_2, y_1, y_2)$ , and index them as  $\bar{v}_{0,i}(1; w_{0,0,i}^*, w_{1,0,i}^*, t_{1,0,i})$ , where  $w_{0,0,i}^* \in \{1, 2, \dots, 2^{N\tilde{R}_{00}}\}$ ,  $w_{1,0,i}^* \in \{1, 2, \dots, 2^{N\tilde{R}_{10}}\}$  and  $t_{1,0,i} \in \{1, 2, \dots, 2^{N(\tilde{R}'_0-\tilde{R}_{10})}\}$ .
  - Produce  $2^{N(\tilde{R}_{00}+\tilde{R}'_0)}$  i.i.d.  $\bar{V}_{0,i}$  w.r.t.  $P(v_0|q, u_1, u_2, y_1, y_2)$ , and label them as  $\bar{v}_{0,i}(2; w_{0,0,i}^*, w_{2,0,i}^*, t_{2,0,i})$ , where  $w_{0,0,i}^* \in \{1, 2, \dots, 2^{N\tilde{R}_{00}}\}$ ,  $w_{2,0,i}^* \in \{1, 2, \dots, 2^{N\tilde{R}_{20}}\}$  and  $t_{2,0,i} \in \{1, 2, \dots, 2^{N(\tilde{R}'_0-\tilde{R}_{20})}\}$ .
- For each possible value of  $\bar{q}_i$ ,  $\bar{u}_{1,i}$ ,  $\bar{u}_{2,i}$ ,  $\bar{y}_{1,i}$  and  $\bar{y}_{2,i}$ , produce  $2^{N(\tilde{R}_{01}+\tilde{R}_{11}+\tilde{R}'_1)}$  i.i.d.  $\bar{V}_{1,i}$  w.r.t.  $P(v_1|q, u_1, u_2, y_1, y_2) = \sum_{v_0, v_2} P(v_0, v_1, v_2|q, u_1, u_2, y_1, y_2)$ , and label them as  $\bar{v}_{1,i}(w_{0,1,i}^*, w_{1,1,i}^*, t_{1,i})$ , where  $w_{0,1,i}^* \in \{1, 2, \dots, 2^{N\tilde{R}_{01}}\}$ ,  $w_{1,1,i}^* \in \{1, 2, \dots, 2^{N\tilde{R}_{11}}\}$  and  $t_{1,i} \in \{1, 2, \dots, 2^{N\tilde{R}'_1}\}$ .
- Analogously, for each possible value of  $\bar{q}_i$ ,  $\bar{u}_{1,i}$ ,  $\bar{u}_{2,i}$ ,  $\bar{y}_{1,i}$  and  $\bar{y}_{2,i}$ , produce  $2^{N(\tilde{R}_{02}+\tilde{R}_{22}+\tilde{R}'_2)}$  i.i.d.  $\bar{V}_{2,i}$  w.r.t.  $P(v_2|q, u_1, u_2, y_1, y_2) = \sum_{v_0, v_1} P(v_0, v_1, v_2|q, u_1, u_2, y_1, y_2)$ , and label them as  $\bar{v}_{2,i}(w_{0,2,i}^*, w_{2,2,i}^*, t_{2,i})$ , where  $w_{0,2,i}^* \in \{1, 2, \dots, 2^{N\tilde{R}_{02}}\}$ ,  $w_{2,2,i}^* \in \{1, 2, \dots, 2^{N\tilde{R}_{22}}\}$  and  $t_{2,i} \in \{1, 2, \dots, 2^{N\tilde{R}'_2}\}$ .

*Encoding procedure:*

- At block 1, the transmitter chooses  $\bar{q}_1(w_{0,1}, 1, 1, 1)$ ,  $\bar{u}_{1,1}(w_{1,1,1}, w_{1,2,1} = 1, w'_{1,1}, w''_{1,1}, 1, 1)$  and  $\bar{u}_{2,1}(w_{2,1,1}, w_{2,2,1} = 1, w'_{2,1}, w''_{2,1}, 1, 1)$  to transmit. Here notice that  $w'_{1,1}$  and  $w'_{2,1}$  are randomly chosen from the sets  $\{1, 2, \dots, 2^{N\tilde{R}'_1}\}$  and  $\{1, 2, \dots, 2^{N\tilde{R}'_2}\}$ , respectively, and the indexes  $w''_{1,1}$  and  $w''_{2,1}$  are chosen by finding a pair of  $(\bar{u}_{1,1}, \bar{u}_{2,1})$  satisfying the condition that given  $\bar{q}_1$ ,  $(\bar{u}_{1,1}, \bar{u}_{2,1}, \bar{q}_1)$  are jointly typical. If multiple pairs exist, choose the pair with the smallest indexes; if no such pair exists, proclaim an encoding error. On the basis of the covering lemma, this kind of encoding error tends to zero if

$$R''_1 + R''_2 \geq I(U_1; U_2|Q). \quad (4.1)$$

- At block  $i$  ( $i \in \{2, 3, \dots, n-1\}$ ), before selecting  $\bar{u}_{1,i}$  and  $\bar{u}_{2,i}$ , generate two mappings  $g_{1,i} : \bar{y}_{1,i-1} \rightarrow \{1, 2, \dots, 2^{NR_{12}}\}$  and  $g_{2,i} : \bar{y}_{2,i-1} \rightarrow \{1, 2, \dots, 2^{NR_{22}}\}$ <sup>3</sup>. On the basis of these two mappings, generate two RVs  $K_{1,i} = g_{1,i}(\bar{Y}_{1,i-1})$  and  $K_{2,i} = g_{2,i}(\bar{Y}_{2,i-1})$  respectively taking values in  $\{1, 2, \dots, 2^{NR_{12}}\}$  and  $\{1, 2, \dots, 2^{NR_{22}}\}$ . Here  $Pr\{K_{1,i} = j\} = 2^{-NR_{12}}$  for  $j \in \{1, 2, \dots, 2^{NR_{12}}\}$ , and  $Pr\{K_{2,i} = l\} = 2^{-NR_{22}}$  for  $l \in \{1, 2, \dots, 2^{NR_{22}}\}$ . The RVs  $K_{1,i}$  and  $K_{2,i}$  are used as secret keys encrypting the messages  $w_{1,2,i}$  and  $w_{2,2,i}$ , respectively, and

<sup>3</sup>Here note that these mappings are generated exactly the same as that in [16]



they are independent of the transmitted messages  $w_{1,2,i}$  and  $w_{2,2,i}$ . The mappings  $g_{1,i}$  and  $g_{2,i}$  are revealed to all parties. Once the transmitter gets  $\bar{y}_{1,i-1}$  and  $\bar{y}_{2,i-1}$ , he seeks a pair of  $(\bar{v}_{0,i-1}, \bar{v}_{1,i-1})$  satisfying the condition that  $(\bar{v}_{0,i-1}(1; \tilde{w}_{0,0,i-1}^*, \tilde{w}_{1,0,i-1}^*, \tilde{t}_{1,0,i-1}), \bar{v}_{1,i-1}(\tilde{w}_{0,1,i-1}^*, \tilde{w}_{1,1,i-1}^*, \tilde{t}_{1,i-1}), \bar{u}_{1,i-1}, \bar{u}_{2,i-1}, \bar{q}_{i-1}, \bar{y}_{1,i-1}, \bar{y}_{2,i-1})$  are jointly typical. For the case that more than one pair  $(\bar{v}_{0,i-1}, \bar{v}_{1,i-1})$  exist, pick one pair at random; if there is no such pair  $(\bar{v}_{0,i-1}, \bar{v}_{1,i-1})$ , declare an encoding error. From the covering lemma, this kind of encoding error tends to zero if

$$\tilde{R}_{00} + \tilde{R}'_0 \geq I(V_0; Q, U_1, U_2, Y_1, Y_2), \quad (4.2)$$

$$\tilde{R}_{01} + \tilde{R}_{11} + \tilde{R}'_1 \geq I(V_1; V_0, Q, U_1, U_2, Y_1, Y_2) \quad (4.3)$$

hold. Here note that (4.2) guarantees that there exists at least one  $\bar{v}_{0,i-1}$  such that  $(\bar{v}_{0,i-1}, \bar{u}_{1,i-1}, \bar{u}_{2,i-1}, \bar{q}_{i-1}, \bar{y}_{1,i-1}, \bar{y}_{2,i-1})$  are jointly typical, and (4.3) guarantees that given  $\bar{v}_{0,i-1}$ , there exists at least one  $\bar{v}_{1,i-1}$  satisfying the condition that  $(\bar{v}_{1,i-1}, \bar{v}_{0,i-1}, \bar{u}_{1,i-1}, \bar{u}_{2,i-1}, \bar{q}_{i-1}, \bar{y}_{1,i-1}, \bar{y}_{2,i-1})$  are jointly typical. Similarly, the transmitter seeks a pair of  $(\bar{v}_{0,i-1}, \bar{v}_{2,i-1})$  satisfying the condition that  $(\bar{v}_{0,i-1}(2; \tilde{w}_{0,0,i-1}^*, \tilde{w}_{2,0,i-1}^*, \tilde{t}_{2,0,i-1}), \bar{v}_{2,i-1}(\tilde{w}_{0,2,i-1}^*, \tilde{w}_{2,2,i-1}^*, \tilde{t}_{2,i-1}), \bar{u}_{1,i-1}, \bar{u}_{2,i-1}, \bar{q}_{i-1}, \bar{y}_{1,i-1}, \bar{y}_{2,i-1})$  are jointly typical. For the case that more than one pair  $(\bar{v}_{0,i-1}, \bar{v}_{2,i-1})$  exist, pick one pair at random; if there is no such pair  $(\bar{v}_{0,i-1}, \bar{v}_{2,i-1})$ , declare an encoding error. From the covering lemma, this kind of encoding error tends to zero if (4.2) and

$$\tilde{R}_{02} + \tilde{R}_{22} + \tilde{R}'_2 \geq I(V_2; V_0, Q, U_1, U_2, Y_1, Y_2) \quad (4.4)$$

hold. Once the transmitter selects the pairs  $(\bar{v}_{0,i-1}, \bar{v}_{1,i-1})$  and  $(\bar{v}_{0,i-1}, \bar{v}_{2,i-1})$ , he chooses  $\bar{q}_i(w_{0,i}, \tilde{w}_{0,0,i-1}^*, \tilde{w}_{0,1,i-1}^*, \tilde{w}_{0,2,i-1}^*), \bar{u}_{1,i}(w_{1,1,i}, w_{1,2,i} \oplus k_{1,i}, w'_{1,i}, w''_{1,i}, \tilde{w}_{1,0,i-1}^*, \tilde{w}_{1,1,i-1}^*)$  and  $\bar{u}_{2,i}(w_{2,1,i}, w_{2,2,i} \oplus k_{2,i}, w'_{2,i}, w''_{2,i}, \tilde{w}_{2,0,i-1}^*, \tilde{w}_{2,2,i-1}^*)$  to transmit. Here note that  $w'_{1,i}$ ,  $w''_{1,i}$ ,  $w'_{2,i}$  and  $w''_{2,i}$  are selected the same as those in block 1.

- At block  $n$ , once the transmitter receives the feedback  $\bar{y}_{1,n-1}$  and  $\bar{y}_{2,n-1}$ , he seeks a pair of  $(\bar{v}_{0,n-1}, \bar{v}_{1,n-1})$  satisfying the condition that  $(\bar{v}_{0,n-1}(1; \tilde{w}_{0,0,n-1}^*, \tilde{w}_{1,0,n-1}^*, \tilde{t}_{1,0,n-1}), \bar{v}_{1,n-1}(\tilde{w}_{0,1,n-1}^*, \tilde{w}_{1,1,n-1}^*, \tilde{t}_{1,n-1}), \bar{u}_{1,n-1}, \bar{u}_{2,n-1}, \bar{q}_{n-1}, \bar{y}_{1,n-1}, \bar{y}_{2,n-1})$  are jointly typical, and the corresponding encoding error tends to zero when (4.2) and (4.3) hold. Similarly, the transmitter seeks a pair of  $(\bar{v}_{0,n-1}, \bar{v}_{2,n-1})$  satisfying the condition that  $(\bar{v}_{0,n-1}(2; \tilde{w}_{0,0,n-1}^*, \tilde{w}_{2,0,n-1}^*, \tilde{t}_{2,0,n-1}), \bar{v}_{2,n-1}(\tilde{w}_{0,2,n-1}^*, \tilde{w}_{2,2,n-1}^*, \tilde{t}_{2,n-1}), \bar{u}_{1,n-1}, \bar{u}_{2,n-1}, \bar{q}_{n-1}, \bar{y}_{1,n-1}, \bar{y}_{2,n-1})$  are jointly typical, and the corresponding encoding error tends to zero when (4.2) and (4.4) hold. Then

the transmitter chooses  $\bar{q}_n(1, \tilde{w}_{0,0,n-1}^*, \tilde{w}_{0,1,n-1}^*, \tilde{w}_{0,2,n-1}^*), \bar{u}_{1,n}(1, 1, 1, 1, \tilde{w}_{1,0,n-1}^*, \tilde{w}_{1,1,n-1}^*)$  and  $\bar{u}_{2,n}(1, 1, 1, 1, \tilde{w}_{2,0,n-1}^*, \tilde{w}_{2,2,n-1}^*)$  to transmit.

*Decoding procedure:*

Receiver  $j$ 's ( $j = 1, 2$ ) decoding procedure begins from block  $n$ . At block  $n$ , Receiver  $j$  seeks a unique  $\bar{q}_n$  jointly typical with  $\bar{y}_{j,n}$ . If there is more than one or no such  $\bar{q}_n$ , declare an decoding error. From the packing lemma, this kind of decoding error tends to zero if

$$\tilde{R}_{00} + \tilde{R}_{01} + \tilde{R}_{02} = \tilde{R}_0 \leq I(Y_j; Q). \quad (4.5)$$

After decoding  $\bar{q}_n$ , Receiver  $j$  seeks a unique  $\bar{u}_{j,n}$  satisfying the condition that  $(\bar{u}_{j,n}, \bar{q}_n, \bar{y}_{j,n})$  are jointly typical. From the packing lemma, this kind of decoding error tends to zero if

$$\tilde{R}_{j0} + \tilde{R}_{j1} = \tilde{R}_j \leq I(Y_j; U_j | Q). \quad (4.6)$$

Once  $\bar{q}_n$  and  $\bar{u}_{j,n}$  are decoded, Receiver  $j$  extracts  $w_{0,0,n-1}^*, w_{0,1,n-1}^*, w_{0,2,n-1}^*, w_{j,0,n-1}^*$  and  $w_{j,j,n-1}^*$  in them. Then on the basis of the extracted messages, Receiver  $j$  seeks a unique pair of  $(\bar{v}_{0,n-1}, \bar{v}_{j,n-1})$  satisfying the condition that  $(\bar{v}_{0,n-1}(j; w_{0,0,n-1}^*, w_{j,0,n-1}^*, t_{j,0,n-1}), \bar{v}_{j,n-1}(w_{0,j,n-1}^*, w_{j,j,n-1}^*, t_{j,n-1}), \bar{y}_{j,n-1})$  are jointly typical. From the packing lemma and the multi-variate packing lemma [23], this kind of decoding error tends to zero if

$$\tilde{R}'_j \leq I(V_j; V_0, Y_j), \quad (4.7)$$

$$\tilde{R}'_j + \tilde{R}'_0 - \tilde{R}_{j0} \leq I(V_0; Y_j) + I(V_j; V_0, Y_j). \quad (4.8)$$

Here notice that (4.7) guarantees the probability of the error event that there is a unique  $\bar{v}_{0,n-1}$  and more than one  $t_{j,n-1}$  satisfying the condition that  $(\bar{v}_{0,n-1}, \bar{v}_{j,n-1}, \bar{y}_{j,n-1})$  are jointly typical tends to zero, and (4.8) guarantees the probability of the error event that there exist more than one  $t_{j,0,n-1}$  and  $t_{j,n-1}$  satisfying the condition that  $(\bar{v}_{0,n-1}, \bar{v}_{j,n-1}, \bar{y}_{j,n-1})$  are jointly typical tends to zero. Then, for block  $n - 1$ , after  $\bar{v}_{0,n-1}$  and  $\bar{v}_{j,n-1}$  are decoded, Receiver  $j$  seeks a unique  $\bar{q}_{n-1}$  satisfying the condition that  $(\bar{q}_{n-1}, \bar{y}_{j,n-1}, \bar{v}_{j,n-1})$  are jointly typical, and from the packing lemma [23], this kind of decoding error tends to zero if

$$R_0 + \tilde{R}_0 \leq I(Q; V_j, Y_j). \quad (4.9)$$

Then Receiver  $j$  seeks a unique  $\bar{u}_{j,n-1}$  satisfying the condition that  $(\bar{u}_{j,n-1}, \bar{q}_{n-1}, \bar{y}_{j,n-1}, \bar{v}_{j,n-1})$  are jointly typical, and this kind of decoding error tends to zero if

$$R_{j1} + R_{j2} + R'_j + R''_j + \tilde{R}_{j0} + \tilde{R}_{j,j} \leq I(U_j; V_j, Y_j | Q). \quad (4.10)$$

When  $\bar{q}_{n-1}$  and  $\bar{u}_{j,n-1}$  are decoded, Receiver  $j$  extracts  $w_{0,n-1}$ ,  $w_{0,0,n-2}^*$ ,  $w_{0,1,n-2}^*$ ,  $w_{0,2,n-2}^*$ ,  $w_{j,1,n-1}$ ,  $w_{j,2,n-1} \oplus k_{j,n-1}$ ,  $w'_{j,n-1}$ ,  $w''_{j,n-1}$ ,  $w_{j,0,n-2}^*$  and  $w_{j,j,n-2}^*$ . Since the key  $k_{j,n-1}$  generated from  $\bar{y}_{j,n-2}$  is also known by Receiver  $j$ , the messages  $w_{j,1,n-1}$  and  $w_{j,2,n-1}$  are correctly decoded by Receiver  $j$ . Repeat the above decoding procedure, the messages of all blocks are decoded by Receiver  $j$ . The following Figs.3-5 help us to better understand the proposed encoding and decoding schemes

Block 1	Encode: $\tilde{q}_1(w_{0,1},1,1,1), \tilde{u}_{1,1}(w_{1,1},1, w'_{1,1}, \bar{w}_{1,1},1,1), \tilde{u}_{2,1}(w_{2,1},1, w'_{2,1}, \bar{w}_{2,1},1,1)$
Block 2	Decode: $\tilde{v}_{0,1}(1; w_{0,0,1}^*, w_{1,0,1}^*, t_{1,0,1}), \tilde{v}_{0,1}(2; w_{0,0,1}^*, w_{2,0,1}^*, t_{2,0,1}), \tilde{v}_{1,1}(w_{0,1,1}^*, w_{1,1,1}^*, t_{1,1}), \tilde{v}_{2,1}(w_{0,2,1}^*, w_{2,2,1}^*, t_{2,1})$ Re-encode: $\tilde{q}_2(w_{0,2}, w_{0,0,1}^*, w_{0,1,1}^*, w_{0,2,1}^*), \tilde{u}_{1,2}(w_{1,1,2}, w_{1,2,2} \oplus k_{1,2}, w'_{1,2}, \bar{w}_{1,2}, w_{1,0,1}^*, w_{1,1,1}^*),$ $\tilde{u}_{2,2}(w_{2,1,2}, w_{2,2,2} \oplus k_{2,2}, w'_{2,2}, \bar{w}_{2,2}, w_{2,0,1}^*, w_{2,2,1}^*)$
...	...
Block n-1	Decode: $\tilde{v}_{0,n-2}(1; w_{0,0,n-2}^*, w_{1,0,n-2}^*, t_{1,0,n-2}), \tilde{v}_{0,n-2}(2; w_{0,0,n-2}^*, w_{2,0,n-2}^*, t_{2,0,n-2}), \tilde{v}_{1,n-2}(w_{0,1,n-2}^*, w_{1,1,n-2}^*, t_{1,n-2}),$ $\tilde{v}_{2,n-2}(w_{0,2,n-2}^*, w_{2,2,n-2}^*, t_{2,n-2})$ Re-encode: $\tilde{q}_{n-1}(w_{0,n-1}, w_{0,0,n-2}^*, w_{0,1,n-2}^*, w_{0,2,n-2}^*), \tilde{u}_{1,n-1}(w_{1,1,n-1}, w_{1,2,n-1} \oplus k_{1,n-1}, w'_{1,n-1}, \bar{w}_{1,n-1}, w_{1,0,n-2}^*, w_{1,1,n-2}^*),$ $\tilde{u}_{2,n-1}(w_{2,1,n-1}, w_{2,2,n-1} \oplus k_{2,n-1}, w'_{2,n-1}, \bar{w}_{2,n-1}, w_{2,0,n-2}^*, w_{2,2,n-2}^*)$
Block n	Decode: $\tilde{v}_{0,n-1}(1; w_{0,0,n-1}^*, w_{1,0,n-1}^*, t_{1,0,n-1}), \tilde{v}_{0,n-1}(2; w_{0,0,n-1}^*, w_{2,0,n-1}^*, t_{2,0,n-1}), \tilde{v}_{1,n-1}(w_{0,1,n-1}^*, w_{1,1,n-1}^*, t_{1,n-1}),$ $\tilde{v}_{2,n-1}(w_{0,2,n-1}^*, w_{2,2,n-1}^*, t_{2,n-1})$ Re-encode: $\tilde{q}_n(1, w_{0,0,n-1}^*, w_{0,1,n-1}^*, w_{0,2,n-1}^*), \tilde{u}_{1,n}(1,1,1,1, w_{1,0,n-1}^*, w_{1,1,n-1}^*), \tilde{u}_{2,n}(1,1,1,1, w_{2,0,n-1}^*, w_{2,2,n-1}^*)$

Fig. 3: The encoding procedure of the transmitter

### Equivocation Analysis for Receiver 2:

Receiver 2's equivocation  $\Delta_1$ , which is denoted by  $\Delta_1 = \frac{1}{nN} H(W_1|Y_2^n)$ , follows that

$$\begin{aligned} \Delta_1 &= \frac{1}{nN} H(W_1|Y_2^n) \stackrel{(a)}{=} \frac{1}{nN} H(\tilde{W}_{11}, \tilde{W}_{12}|Y_2^n) \\ &= \frac{1}{nN} (H(\tilde{W}_{11}|Y_2^n) + H(\tilde{W}_{12}|Y_2^n, \tilde{W}_{11})), \end{aligned} \quad (4.11)$$

where (a) follows from the definitions  $\tilde{W}_{11} = (W_{1,1,1}, \dots, W_{1,1,n})$  and  $\tilde{W}_{12} = (W_{1,2,1}, \dots, W_{1,2,n})$ .

The first term  $H(\tilde{W}_{11}|Y_2^n)$  of (4.11) follows that

$$\begin{aligned} H(\tilde{W}_{11}|Y_2^n) &\geq H(\tilde{W}_{11}|Y_2^n, Q^n, U_2^n, V_2^n) \\ &= H(\tilde{W}_{11}, Y_2^n, Q^n, U_2^n, V_2^n) - H(Y_2^n, Q^n, U_2^n, V_2^n) \end{aligned}$$

Block n	<p>Decode:</p> $\tilde{q}_n(\mathbf{1}, w_{0,0,n-1}^*, w_{0,1,n-1}^*, w_{0,2,n-1}^*), \tilde{u}_{1,n-1}(\mathbf{1}, \mathbf{1}, \mathbf{1}, w_{1,0,n-1}^*, w_{1,1,n-1}^*)$ <p>Extract: <math>w_{0,0,n-1}^*, w_{0,1,n-1}^*, w_{0,2,n-1}^*, w_{1,0,n-1}^*, w_{1,1,n-1}^*</math></p> <p>Decode: <math>\tilde{v}_{0,n-1}(\mathbf{1}; w_{0,0,n-1}^*, w_{1,0,n-1}^*, t_{1,0,n-1}), \tilde{v}_{1,n-1}(w_{0,1,n-1}^*, w_{1,1,n-1}^*, t_{1,n-1})</math></p>
Block n-1	<p>Decode:</p> $\tilde{q}_{n-1}(w_{0,0,n-1}^*, w_{0,0,n-2}^*, w_{0,1,n-2}^*, w_{0,2,n-2}^*), \tilde{u}_{1,n-1}(w_{1,1,n-1}, w_{1,2,n-1} \oplus k_{1,n-1}, w_{1,n-1}^*, w_{1,n-1}^*, w_{1,0,n-2}^*, w_{1,1,n-2}^*)$ <p>Extract: <math>w_{0,0,n-1}^*, w_{0,0,n-2}^*, w_{0,1,n-2}^*, w_{0,2,n-2}^*, w_{1,1,n-1}, w_{1,2,n-1}, w_{1,n-1}^*, w_{1,n-1}^*, w_{1,0,n-2}^*, w_{1,1,n-2}^*</math></p> <p>Decode: <math>\tilde{v}_{0,n-2}(\mathbf{1}; w_{0,0,n-2}^*, w_{1,0,n-2}^*, t_{1,0,n-2}), \tilde{v}_{1,n-2}(w_{0,1,n-2}^*, w_{1,1,n-2}^*, t_{1,n-2}),</math></p>
...	...
Block 2	<p>Given <math>\tilde{v}_{0,2}(\mathbf{1}; w_{0,0,2}^*, w_{1,0,2}^*, t_{1,0,2}), \tilde{v}_{1,2}(w_{0,1,2}^*, w_{1,1,2}^*, t_{1,2})</math></p> <p>Decode:</p> $\tilde{q}_2(w_{0,2}, w_{0,0,1}^*, w_{0,1,1}^*, w_{0,2,1}^*), \tilde{u}_{1,2}(w_{1,1,2}, w_{1,2,2} \oplus k_{1,2}, w_{1,2}^*, w_{1,2}^*, w_{1,0,1}^*, w_{1,1,1}^*)$ <p>Extract: <math>w_{0,2}, w_{0,0,1}^*, w_{0,1,1}^*, w_{0,2,1}^*, w_{1,1,2}, w_{1,2,2}, w_{1,2}^*, w_{1,2}^*, w_{1,0,1}^*, w_{1,1,1}^*</math></p> <p>Decode: <math>\tilde{v}_{0,1}(\mathbf{1}; w_{0,0,1}^*, w_{1,0,1}^*, t_{1,0,1}), \tilde{v}_{1,1}(w_{0,1,1}^*, w_{1,1,1}^*, t_{1,1})</math></p>
Block 1	<p>Decode:</p> $\tilde{q}_1(w_{0,1}, \mathbf{1}, \mathbf{1}, \mathbf{1}), \tilde{u}_{1,1}(w_{1,1,1}, \mathbf{1}, w_{1,2}^*, w_{1,2}^*, \mathbf{1}, \mathbf{1})$ <p>Extract: <math>w_{0,1}, w_{1,1,1}, w_{1,1}^*, w_{1,1}^*</math></p>

Fig. 4: The decoding procedure of Receiver 1

$$\begin{aligned}
&= H(\tilde{W}_{11}, Y_2^n, Q^n, U_2^n, V_2^n, U_1^n) - H(U_1^n | \tilde{W}_{11}, Y_2^n, Q^n, U_2^n, V_2^n) - H(Y_2^n, Q^n, U_2^n, V_2^n) \\
&\stackrel{(b)}{=} H(Y_2^n, V_2^n | Q^n, U_2^n, U_1^n) + H(Q^n, U_2^n, U_1^n) - H(U_1^n | \tilde{W}_{11}, Y_2^n, Q^n, U_2^n, V_2^n) \\
&\quad - H(Y_2^n, V_2^n | Q^n, U_2^n) - H(Q^n, U_2^n) \\
&= H(Y_2^n, V_2^n | Q^n, U_2^n, U_1^n) + H(U_1^n | Q^n, U_2^n) - H(U_1^n | \tilde{W}_{11}, Y_2^n, Q^n, U_2^n, V_2^n) \\
&\quad - H(Y_2^n, V_2^n | Q^n, U_2^n) \\
&= H(U_1^n | Q^n) - I(U_1^n; U_2^n | Q^n) - H(U_1^n | \tilde{W}_{11}, Y_2^n, Q^n, U_2^n, V_2^n) \\
&\quad - I(U_1^n; Y_2^n, V_2^n | Q^n, U_2^n) \\
&\stackrel{(c)}{=} H(U_1^n | Q^n) - nNI(U_1; U_2 | Q) - nNI(U_1; Y_2, V_2 | Q, U_2) - H(U_1^n | \tilde{W}_{11}, Y_2^n, Q^n, U_2^n, V_2^n) \\
&\stackrel{(d)}{=} (n-1)N(R_{11} + R'_1 + R''_1 + \tilde{R}_{10} + \tilde{R}_{11}) + (n-2)NR_{12} - nNI(U_1; U_2 | Q) \\
&\quad - nNI(U_1; Y_2, V_2 | Q, U_2) - H(U_1^n | \tilde{W}_{11}, Y_2^n, Q^n, U_2^n, V_2^n) \\
&\stackrel{(e)}{\geq} (n-1)N(R_{11} + R'_1 + R''_1 + \tilde{R}_{10} + \tilde{R}_{11}) + (n-2)NR_{12}
\end{aligned}$$

Block n	<p>Decode:</p> $\tilde{q}_n(1, w_{0,0,n-1}^*, w_{0,1,n-1}^*, w_{0,2,n-1}^*), \tilde{u}_{2,2}(1,1,1,1, w_{2,0,n-1}^*, w_{2,2,n-1}^*)$ <p>Extract: <math>w_{0,0,n-1}^*, w_{0,1,n-1}^*, w_{0,2,n-1}^*, w_{2,0,n-1}^*, w_{2,2,n-1}^*</math></p> <p>Decode: <math>\tilde{v}_{0,n-1}(2; w_{0,0,n-1}^*, w_{2,0,n-1}^*, t_{2,0,n-1}), \tilde{v}_{2,n-1}(w_{0,2,n-1}^*, w_{2,2,n-1}^*, t_{2,n-1})</math></p>
Block n-1	<p>Decode:</p> $\tilde{q}_{n-1}(w_{0,n-1}^*, w_{0,0,n-2}^*, w_{0,1,n-2}^*, w_{0,2,n-2}^*), \tilde{u}_{2,n-1}(w_{2,1,n-1}, w_{2,2,n-1} \oplus k_{2,n-1}, w_{2,n-1}^*, w_{2,n-1}^*, w_{2,0,n-2}^*, w_{2,2,n-2}^*)$ <p>Extract: <math>w_{0,n-1}^*, w_{0,0,n-2}^*, w_{0,1,n-2}^*, w_{0,2,n-2}^*, w_{2,1,n-1}, w_{2,2,n-1}, w_{2,n-1}^*, w_{2,n-1}^*, w_{2,0,n-2}^*, w_{2,2,n-2}^*</math></p> <p>Decode: <math>\tilde{v}_{0,n-2}(2; w_{0,0,n-2}^*, w_{2,0,n-2}^*, t_{2,0,n-2}), \tilde{v}_{2,n-2}(w_{0,2,n-2}^*, w_{2,2,n-2}^*, t_{2,n-2})</math></p>
...	...
Block 2	<p>Given <math>\tilde{v}_{0,2}(2; w_{0,0,2}^*, w_{2,0,2}^*, t_{2,0,2}), \tilde{v}_{2,2}(w_{0,2,2}^*, w_{2,2,2}^*, t_{2,2})</math></p> <p>Decode:</p> $\tilde{q}_2(w_{0,2}^*, w_{0,0,1}^*, w_{0,1,1}^*, w_{0,2,1}^*), \tilde{u}_{2,2}(w_{2,1,2}, w_{2,2,2} \oplus k_{2,2}, w_{2,2}^*, w_{2,2}^*, w_{2,0,1}^*, w_{2,2,1}^*)$ <p>Extract: <math>w_{0,2}^*, w_{0,0,1}^*, w_{0,1,1}^*, w_{0,2,1}^*, w_{2,1,2}, w_{2,2,2}, w_{2,2}^*, w_{2,2}^*, w_{2,0,1}^*, w_{2,2,1}^*</math></p> <p>Decode: <math>\tilde{v}_{0,1}(2; w_{0,0,1}^*, w_{2,0,1}^*, t_{2,0,1}), \tilde{v}_{2,1}(w_{0,2,1}^*, w_{2,2,1}^*, t_{2,1})</math></p>
Block 1	<p>Decode:</p> $\tilde{q}_1(w_{0,1}, 1, 1, 1), \tilde{u}_{2,1}(w_{2,1,1}, 1, w_{2,2}^*, w_{2,2}^*, 1, 1)$ <p>Extract: <math>w_{0,1}, w_{2,1,1}, w_{2,1}^*, w_{2,1}^*</math></p>

Fig. 5: The decoding procedure of Receiver 2

$$-nNI(U_1; U_2|Q) - nNI(U_1; Y_2, V_2|Q, U_2) - nN\epsilon_3, \quad (4.12)$$

where (b) follows from  $H(\tilde{W}_{11}|U_1^n) = 0$ , (c) follows from the generation of  $Q^n, U_1^n, U_2^n, V_1^n, V_2^n$  and the channel is memoryless, and (d) follows from the generation of  $U_1^n$ , and (e) follows from that given  $\tilde{w}_{11}, y_2^n, v_2^n, q^n$  and  $u_2^n$ , Receiver 2 seeks a unique  $u_1^n$  that is jointly typical with his own received signals  $y_2^n, v_2^n, q^n, u_2^n$ , and from the packing lemma, we see that Receiver 2's decoding error tends to zero if

$$R_{12} + R'_1 + \tilde{R}_{10} + \tilde{R}_{11} \leq I(Y_2, V_2; U_1|Q, U_2), \quad (4.13)$$

then applying Fano's lemma,  $\frac{1}{nN}H(U_1^n|\tilde{W}_{11}, Y_2^n, Q^n, U_2^n, V_2^n) \leq \epsilon_3$  is obtained, where  $\epsilon_3 \rightarrow 0$  while  $n, N \rightarrow \infty$ .

The second term  $H(\tilde{W}_{12}|Y_2^n, \tilde{W}_{11})$  of (4.11) is bounded by

$$\begin{aligned} & H(\tilde{W}_{12}|Y_2^n, \tilde{W}_{11}) \\ & \geq \sum_{i=2}^{n-1} H(W_{1,2,i}|Y_2^n, \tilde{W}_{11}, W_{1,2,1} = 1, \dots, W_{1,2,i-1}, W_{1,2,i} \oplus K_{1,i}) \end{aligned}$$

$$\begin{aligned}
& \stackrel{(f)}{=} \sum_{i=2}^{n-1} H(W_{1,2,i} | \bar{Y}_{2,i-1}, W_{1,2,i} \oplus K_{1,i}) \\
& \geq \sum_{i=2}^{n-1} H(W_{1,2,i} | \bar{Y}_{2,i-1}, W_{1,2,i} \oplus K_{1,i}, \bar{V}_{2,i-1}, \bar{Q}_{i-1}, \bar{U}_{1,i-1}, \bar{U}_{2,i-1}) \\
& = \sum_{i=2}^{n-1} H(K_{1,i} | \bar{Y}_{2,i-1}, W_{1,2,i} \oplus K_{1,i}, \bar{V}_{2,i-1}, \bar{Q}_{i-1}, \bar{U}_{1,i-1}, \bar{U}_{2,i-1}) \\
& \stackrel{(g)}{=} \sum_{i=2}^{n-1} H(K_{1,i} | \bar{Y}_{2,i-1}, \bar{V}_{2,i-1}, \bar{Q}_{i-1}, \bar{U}_{1,i-1}, \bar{U}_{2,i-1}) \\
& \stackrel{(h)}{\geq} (n-2) \left( \log \frac{1-\epsilon_1}{1+\delta} + N(1-\epsilon_2) H(Y_1 | Y_2, V_2, Q, U_1, U_2) \right), \tag{4.14}
\end{aligned}$$

where (f) follows from the Markov chain  $W_{1,2,i} \rightarrow (\bar{Y}_{2,i-1}, W_{1,2,i} \oplus K_{1,i}) \rightarrow (\bar{W}_{11}, W_{1,2,1}, \dots, W_{1,2,i-1}, \bar{Y}_{2,1}, \dots, \bar{Y}_{2,i-2}, \bar{Y}_{2,i}, \dots, \bar{Y}_{2,n})$ , (g) follows from  $K_{1,i} \rightarrow (\bar{Y}_{2,i-1}, \bar{V}_{2,i-1}, \bar{Q}_{i-1}, \bar{U}_{1,i-1}, \bar{U}_{2,i-1}) \rightarrow W_{1,2,i} \oplus K_{1,i}$ , and (h) follows from Lemma 3 that given  $\bar{y}_{2,i-1}$ ,  $\bar{q}_{i-1}$ ,  $\bar{u}_{1,i-1}$ ,  $\bar{u}_{2,i-1}$  and  $\bar{v}_{2,i-1}$ , there are at least  $\frac{\gamma}{1+\delta}$  colors (see (2.2)), which indicates that

$$H(K_{1,i} | \bar{Y}_{2,i-1}, \bar{V}_{2,i-1}, \bar{Q}_{i-1}, \bar{U}_{1,i-1}, \bar{U}_{2,i-1}) \geq \log \frac{\gamma}{1+\delta}, \tag{4.15}$$

then substituting (2.3) into (4.15), we get

$$\begin{aligned}
& H(K_{1,i} | \bar{Y}_{2,i-1}, \bar{V}_{2,i-1}, \bar{Q}_{i-1}, \bar{U}_{1,i-1}, \bar{U}_{2,i-1}) \\
& \geq \log \frac{1-\epsilon_1}{1+\delta} + N(1-\epsilon_2) H(Y_1 | Y_2, V_2, Q, U_1, U_2), \tag{4.16}
\end{aligned}$$

where  $\epsilon_1$ ,  $\epsilon_2$  and  $\delta$  tend to 0 while  $N$  goes to infinity.

Substituting (4.14) and (4.12) into (4.11), we get

$$\begin{aligned}
\Delta_1 & \geq \frac{n-1}{n} (R_{11} + R'_1 + R''_1 + \tilde{R}_{10} + \tilde{R}_{11}) + \frac{n-2}{n} R_{12} - I(U_1; U_2 | Q) \\
& \quad - I(V_2, Y_2; U_1 | Q, U_2) - \epsilon_3 + \frac{n-2}{nN} \log \frac{1-\epsilon_1}{1+\delta} + \frac{n-2}{n} (1-\epsilon_2) H(Y_1 | Y_2, V_2, Q, U_1, U_2). \tag{4.17}
\end{aligned}$$

The bound (4.17) implies that if

$$R'_1 + R''_1 + \tilde{R}_{10} + \tilde{R}_{11} \geq I(U_1; U_2 | Q) + I(V_2, Y_2; U_1 | Q, U_2) - H(Y_1 | Y_2, V_2, Q, U_1, U_2), \tag{4.18}$$

$\Delta_1 \geq R_1 - \epsilon$  is obtained by choosing sufficiently large  $n$  and  $N$ .

*Equivocation Analysis for Receiver 1:* The equivocation analysis of Receiver 1's equivocation  $\Delta_2 = \frac{1}{nN}H(W_2|Y_1^n)$  is analogous to that of  $\Delta_1$ , hence  $\Delta_2 \geq R_2 - \epsilon$  can be proved by letting

$$R_{22} + R_2' + \tilde{R}_{20} + \tilde{R}_{22} \leq I(Y_1, V_1; U_2|Q, U_1), \quad (4.19)$$

$$\begin{aligned} & R_2' + R_2'' + \tilde{R}_{20} + \tilde{R}_{22} \\ & \geq I(U_1; U_2|Q) + I(V_1, Y_1; U_2|Q, U_1) - H(Y_2|Y_1, V_1, Q, U_1, U_2), \end{aligned} \quad (4.20)$$

and selecting sufficiently large  $n$  and  $N$ .

Now using the fact that  $\tilde{R}_0 = \tilde{R}_{00} + \tilde{R}_{01} + \tilde{R}_{02}$ ,  $\tilde{R}_1 = \tilde{R}_{10} + \tilde{R}_{11}$ ,  $\tilde{R}_2 = \tilde{R}_{20} + \tilde{R}_{22}$ , and applying Fourier-Motzkin elimination to remove  $\tilde{R}'_0$ ,  $\tilde{R}'_1$  and  $\tilde{R}'_2$  from (4.2)-(4.8), we have

$$\tilde{R}_0 + \tilde{R}_1 \geq I(V_0, V_1; Q, U_1, U_2, Y_1, Y_2|Y_1) \quad (4.21)$$

$$\tilde{R}_0 + \tilde{R}_2 \geq I(V_0, V_2; Q, U_1, U_2, Y_1, Y_2|Y_2) \quad (4.22)$$

$$\begin{aligned} & \tilde{R}_0 + \tilde{R}_1 + \tilde{R}_2 \geq I(V_1; Q, U_1, U_2, Y_1, Y_2|Y_1, V_0) + I(V_2; Q, U_1, U_2, Y_1, Y_2|Y_2, V_0) \\ & + \max\{I(V_0; Q, U_1, U_2, Y_1, Y_2|Y_1), I(V_0; Q, U_1, U_2, Y_1, Y_2|Y_2)\}. \end{aligned} \quad (4.23)$$

Then, further using the fact that  $R_1 = R_{11} + R_{12}$  and  $R_2 = R_{21} + R_{22}$ , and applying Fourier-Motzkin elimination to remove  $R'_1$ ,  $R''_1$ ,  $R'_2$ ,  $R''_2$ ,  $\tilde{R}_0$ ,  $\tilde{R}_1$  and  $\tilde{R}_2$  from (4.21), (4.22), (4.23), (4.1), (4.9), (4.10), (4.13), (4.18), (4.19) and (4.20), Theorem 2 is proved.

## V. EXAMPLES

### A. Dueck-type Example

In this subsection, we further explain the inner and outer bounds on the secrecy capacity region of the BC-MSR with noiseless feedback via a Dueck-type example. In this example (see Figure 6), the channel input and outputs satisfy

$$\begin{aligned} X &= (X_0, X_1, X_2), Y_1 = (Y_{10}, Y_{11}), Y_2 = (Y_{20}, Y_{21}), \\ Y_{10} &= Y_{20} = X_0 \oplus Z_0, Y_{11} = X_1 \oplus Z_1, Y_{21} = X_2 \oplus Z_2, \end{aligned} \quad (5.1)$$

where the channel inputs  $X_0, X_1, X_2$  and the channel noises  $Z_0, Z_1, Z_2$  are binary random variables (taking values in  $\{0, 1\}$ ), and the channel noises are independent of the channel inputs.

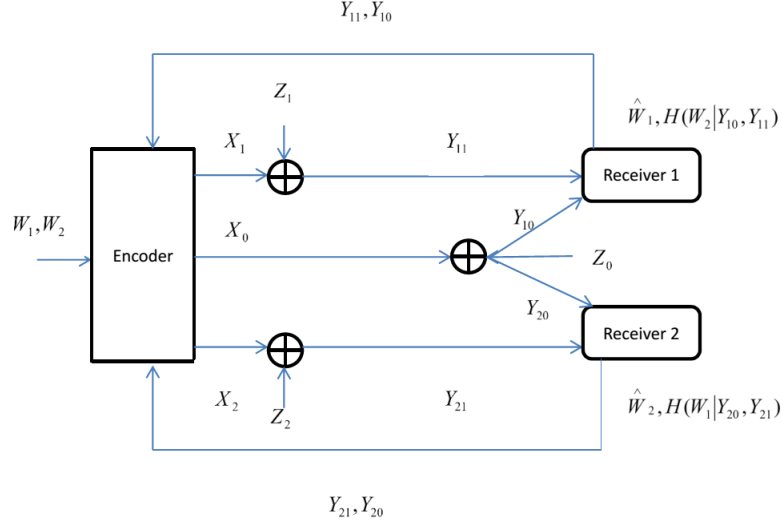

Fig. 6: A Dueck-type example of the BC-MSR with noiseless feedback

First, we show the secret key based inner bound  $\mathcal{C}_s^{f-in-1}$  on the secrecy capacity region of this Dueck-type example. Letting

$$\begin{aligned}
 P(X_0 = 0) &= \alpha_1, \quad P(X_0 = 1) = 1 - \alpha_1, \\
 P(X_1 = 0) &= \alpha_2, \quad P(X_1 = 1) = 1 - \alpha_2, \\
 P(X_2 = 0) &= \alpha_3, \quad P(X_2 = 1) = 1 - \alpha_3,
 \end{aligned} \tag{5.2}$$

and substituting  $Q = X_0$ ,  $U_1 = X_1$ ,  $U_2 = X_2$  and (5.1) into Theorem 3,  $\mathcal{C}_s^{f-in-1}$  reduces to  $\mathcal{C}_{sf}^{in-1}$ , and it is given by

$$\begin{aligned}
 \mathcal{C}_{sf}^{in-1} &= \{(R_1, R_2) : R_1 \leq 1 - H(Z_1|Z_0) + H(Z_1|Z_0, Z_2), \\
 &R_2 \leq 1 - H(Z_2|Z_0) + H(Z_2|Z_0, Z_1), \\
 &R_1 \leq 2 - H(Z_0, Z_1), \quad R_2 \leq 2 - H(Z_0, Z_2), \\
 &R_1 + R_2 \leq 3 + H(Z_0) - H(Z_0, Z_1) - H(Z_0, Z_2)\}.
 \end{aligned} \tag{5.3}$$

Here note that (5.3) is obtained when  $\alpha_1 = \alpha_2 = \alpha_3 = \frac{1}{2}$ .

Second, we show the hybrid inner bound  $\mathcal{C}_s^{f-in-2}$  on the secrecy capacity region of this Dueck-type example. Substituting (5.2),  $Q = X_0$ ,  $U_1 = X_1$ ,  $U_2 = X_2$ ,  $V_1 = (X_0, X_1)$ ,  $V_2 = (X_0, X_2)$ ,



(5.1),  $V_0 = (Z_0, Z_1)$  or  $V_0 = (Z_0, Z_2)$  into Theorem 2,  $\mathcal{C}_s^{f-in-2}$  reduces to  $\mathcal{C}_{sf}^{in-2}$ , and it is given by

$$\begin{aligned} \mathcal{C}_{sf}^{in-2} &= \{(R_1, R_2) : R_1 \leq 1 + H(Z_1|Z_0, Z_2), R_2 \leq 1 + H(Z_2|Z_0, Z_1), \\ &R_1 \leq 2 - H(Z_0, Z_1), R_2 \leq 2 - H(Z_0, Z_2), \\ &R_1 + R_2 \leq 3 - H(Z_0, Z_1, Z_2)\}. \end{aligned} \quad (5.4)$$

Third, we show a simple cut-set outer bound  $\mathcal{C}_{sf}^{out}$  on the secrecy capacity region of this Dueck-type example. Since only  $X_0$  and  $X_1$  are transmitted to receiver 1, the transmission rate  $R_1$  of the message  $W_1$  is upper bounded by  $I(X_0, X_1; Y_1)$ . Analogously, the transmission rate  $R_2$  is upper bounded by  $I(X_0, X_2; Y_2)$ . For all receivers, the sum rate  $R_1 + R_2$  is upper bounded by  $I(X_0, X_1, X_2; Y_1, Y_2)$ . Now it remains to calculate these upper bounds. Since  $X_0, X_1, X_2, Z_0, Z_1$  and  $Z_2$  take values in  $\{0, 1\}$ , from (5.1), we have

$$\begin{aligned} I(X_0, X_1; Y_1) &= H(X_0 \oplus Z_0, X_1 \oplus Z_1) - H(X_0 \oplus Z_0, X_1 \oplus Z_1 | X_0, X_1) \\ &= H(X_0 \oplus Z_0, X_1 \oplus Z_1) - H(Z_0, Z_1 | X_0, X_1) \\ &\stackrel{(1)}{=} H(X_0 \oplus Z_0, X_1 \oplus Z_1) - H(Z_0, Z_1) \\ &\leq H(X_0 \oplus Z_0) + H(X_1 \oplus Z_1) - H(Z_0, Z_1) \\ &\leq 2 - H(Z_0, Z_1), \end{aligned} \quad (5.5)$$

where (1) follows from the fact that the channel noises are independent of the channel inputs. Analogously, we have

$$I(X_0, X_2; Y_2) \leq 2 - H(Z_0, Z_2). \quad (5.6)$$

For  $I(X_0, X_1, X_2; Y_1, Y_2)$ , we have

$$\begin{aligned} &I(X_0, X_1, X_2; Y_1, Y_2) \\ &= H(X_0 \oplus Z_0, X_1 \oplus Z_1, X_2 \oplus Z_2) - H(X_0 \oplus Z_0, X_1 \oplus Z_1, X_2 \oplus Z_2 | X_0, X_1, X_2) \\ &= H(X_0 \oplus Z_0, X_1 \oplus Z_1, X_2 \oplus Z_2) - H(Z_0, Z_1, Z_2 | X_0, X_1, X_2) \\ &\stackrel{(2)}{=} H(X_0 \oplus Z_0, X_1 \oplus Z_1, X_2 \oplus Z_2) - H(Z_0, Z_1, Z_2) \\ &\leq H(X_0 \oplus Z_0) + H(X_1 \oplus Z_1) + H(X_2 \oplus Z_2) - H(Z_0, Z_1, Z_2) \\ &\leq 3 - H(Z_0, Z_1, Z_2), \end{aligned} \quad (5.7)$$

where (2) also follows from the fact that the channel noises are independent of the channel inputs. Combining (5.5), (5.6) with (5.7), an outer bound  $\mathcal{C}_{sf}^{out}$  on the secrecy capacity region of this Dueck-type example is given by

$$\begin{aligned} \mathcal{C}_{sf}^{out} = \{ & (R_1, R_2) : R_1 \leq 2 - H(Z_0, Z_1), R_2 \leq 2 - H(Z_0, Z_2), \\ & R_1 + R_2 \leq 3 - H(Z_0, Z_1, Z_2)\}. \end{aligned} \quad (5.8)$$

Finally, in order to show the advantage of feedback, we also give an inner bound  $\mathcal{C}_s^{in}$  on the secrecy capacity region of the Dueck-type example without the feedback. Here notice that in [12], an achievable secrecy rate region  $\mathcal{C}_s^{in*}$  for the BC-MSR is proposed, and it is given by

$$\begin{aligned} \mathcal{C}_s^{in*} = \{ & (R_1, R_2) : 0 \leq R_1 \leq I(U_1; Y_1|Q) - I(U_1; U_2|Q) - I(U_1; Y_2|Q, U_2), \\ & 0 \leq R_2 \leq I(U_2; Y_2|Q) - I(U_1; U_2|Q) - I(U_2; Y_1|Q, U_1)\}. \end{aligned} \quad (5.9)$$

Now substituting  $Q = X_0$ ,  $U_1 = X_1$ ,  $U_2 = X_2$ , (5.2) and (5.1) into (5.9),  $\mathcal{C}_s^{in*}$  reduces to  $\mathcal{C}_s^{in}$ , and it is given by

$$\mathcal{C}_s^{in} = \{(R_1, R_2) : R_1 \leq 1 - H(Z_1|Z_0), R_2 \leq 1 - H(Z_2|Z_0)\}. \quad (5.10)$$

Here note that (5.10) is obtained when  $\alpha_1 = \alpha_2 = \alpha_3 = \frac{1}{2}$ .

In order to compare the above bounds, we further define the channel noises  $Z_0$ ,  $Z_1$  and  $Z_2$  in the following two cases:

- Case 1: The channel noise  $Z_2$  only depends on  $Z_1$ , i.e., there exists a Markov chain  $Z_0 \rightarrow Z_1 \rightarrow Z_2$ .
- Case 2: The channel noises  $Z_1$  and  $Z_2$  only depend on the noise  $Z_0$ , i.e., there exists a Markov chain  $Z_1 \rightarrow Z_0 \rightarrow Z_2$ .

In the remainder of this subsection, we show the numerical results on the above two cases of this Dueck-type example, see the followings.

1) *A special case of Dueck-type example with  $Z_0 \rightarrow Z_1 \rightarrow Z_2$ :* For the case  $Z_0 \rightarrow Z_1 \rightarrow Z_2$ , define

$$\left\{ \begin{array}{l} P(Z_0 = 0) = 1 - p, P(Z_0 = 1) = p, \\ P(Z_1 = 0|Z_0 = 0) = 1 - q, P(Z_1 = 1|Z_0 = 0) = q, \\ P(Z_1 = 0|Z_0 = 1) = q, P(Z_1 = 1|Z_0 = 1) = 1 - q, \\ P(Z_2 = 0|Z_1 = 0) = 1 - r, P(Z_2 = 1|Z_1 = 0) = r, \\ P(Z_2 = 0|Z_1 = 1) = r, P(Z_2 = 1|Z_1 = 1) = 1 - r \end{array} \right\}, \quad (5.11)$$

where  $0 \leq p, q, r \leq \frac{1}{2}$ . Substituting (5.16) and  $Z_0 \rightarrow Z_1 \rightarrow Z_2$  into (5.3), (5.4), (5.8) and (5.10), we have

$$\begin{aligned} \mathcal{C}_{sf}^{in-1} &= \{(R_1, R_2) : R_1 \leq 1 - h(r \star q) + h(r), R_2 \leq 1 - h(r \star q) + h(r), \\ R_1 &\leq 2 - h(p) - h(q), R_2 \leq 2 - h(p) - h(r \star q), \\ R_1 + R_2 &\leq 3 - h(q) - h(p) - h(r \star q)\}, \end{aligned} \quad (5.12)$$

$$\begin{aligned} \mathcal{C}_{sf}^{in-2} &= \{(R_1, R_2) : R_1 \leq 1 + h(q) - h(r \star q) + h(r), R_2 \leq 1 + h(r), \\ R_1 &\leq 2 - h(p) - h(q), R_2 \leq 2 - h(p) - h(r \star q), \\ R_1 + R_2 &\leq 3 - h(p) - h(q) - h(r)\}, \end{aligned} \quad (5.13)$$

$$\begin{aligned} \mathcal{C}_{sf}^{out} &= \{(R_1, R_2) : R_1 \leq 2 - h(p) - h(q), R_2 \leq 2 - h(p) - h(r \star q), \\ R_1 + R_2 &\leq 3 - h(p) - h(q) - h(r)\}, \end{aligned} \quad (5.14)$$

$$\mathcal{C}_s^{in} = \{(R_1, R_2) : R_1 \leq 1 - h(q), R_2 \leq 1 - h(r \star q)\}, \quad (5.15)$$

where  $a \star b = a(1-b) + (1-a)b$  and  $h(a) = -a \log(a) - (1-a) \log(1-a)$  ( $0 \leq a \leq 1$ ). Figure 7 depicts  $\mathcal{C}_{sf}^{in-1}$ ,  $\mathcal{C}_{sf}^{in-2}$ ,  $\mathcal{C}_{sf}^{out}$  and  $\mathcal{C}_s^{in}$  for  $p = q = r = 0.05$ . From this figure, we conclude that the hybrid feedback strategy performs better than the secret key based feedback strategy, and both of these strategies increase the secrecy rate region of the BC-MSR. Moreover, note that there is still a gap between the inner and outer bounds on the secrecy capacity region of the BC-MSR with noiseless feedback.

Figure 8 plots  $\mathcal{C}_{sf}^{in-1}$ ,  $\mathcal{C}_{sf}^{in-2}$ ,  $\mathcal{C}_{sf}^{out}$  and  $\mathcal{C}_s^{in}$  for  $p = 0.25$ ,  $q = 0.2$  and  $r = 0.3$ . From Figure 8, we conclude that for this case, the secrecy capacity region of the BC-MSR with noiseless feedback is determined, and this is because the outer bound  $\mathcal{C}_{sf}^{out}$  meets with the hybrid strategy inner bound  $\mathcal{C}_{sf}^{in-2}$ . Also, we see that the hybrid feedback coding strategy performs better than the secret key based feedback strategy, and both of them increase the secrecy rate region of the BC-MSR.

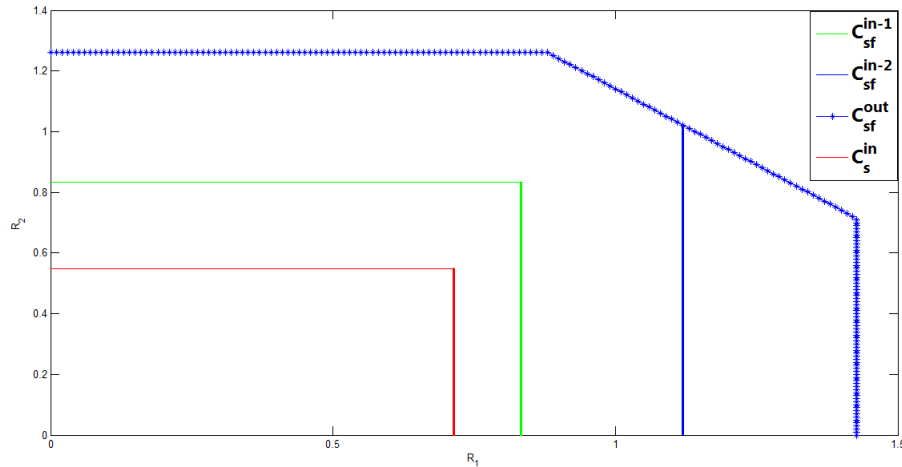

Fig. 7: Comparison of the bounds for the case  $Z_0 \rightarrow Z_1 \rightarrow Z_2$  and  $p = q = r = 0.05$

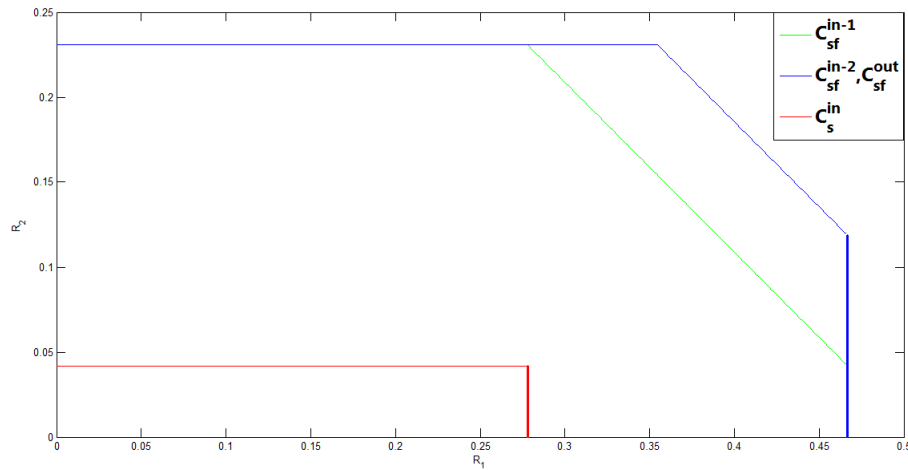

Fig. 8: Comparison of the bounds for the case  $Z_0 \rightarrow Z_1 \rightarrow Z_2$  and  $p = 0.25$ ,  $q = 0.2$ ,  $r = 0.3$

2) *A special case of Dueck-type example with  $Z_1 \rightarrow Z_0 \rightarrow Z_2$ :* For the case  $Z_1 \rightarrow Z_0 \rightarrow Z_2$ , define

$$\left\{ \begin{array}{l} P(Z_0 = 0) = 1 - p, P(Z_0 = 1) = p, \\ P(Z_1 = 0|Z_0 = 0) = 1 - q, P(Z_1 = 1|Z_0 = 0) = q, \\ P(Z_1 = 0|Z_0 = 1) = q, P(Z_1 = 1|Z_0 = 1) = 1 - q, \\ P(Z_2 = 0|Z_0 = 0) = 1 - r, P(Z_2 = 1|Z_0 = 0) = r, \\ P(Z_2 = 0|Z_0 = 1) = r, P(Z_2 = 1|Z_0 = 1) = 1 - r \end{array} \right\}, \quad (5.16)$$

where  $0 \leq p, q, r \leq \frac{1}{2}$ . Substituting (5.16) and  $Z_0 \rightarrow Z_1 \rightarrow Z_2$  into (5.3), (5.4), (5.8) and (5.10), we have

$$\begin{aligned} \mathcal{C}_{sf}^{in-1} &= \{(R_1, R_2) : R_1 \leq 1, R_2 \leq 1, \\ &R_1 \leq 2 - h(p) - h(q), R_2 \leq 2 - h(p) - h(r), \\ &R_1 + R_2 \leq 3 - h(q) - h(p) - h(r)\}, \end{aligned} \quad (5.17)$$

$$\begin{aligned} \mathcal{C}_{sf}^{in-2} &= \{(R_1, R_2) : R_1 \leq 1 + h(q), R_2 \leq 1 + h(r), \\ &R_1 \leq 2 - h(p) - h(q), R_2 \leq 2 - h(p) - h(r), \\ &R_1 + R_2 \leq 3 - h(p) - h(q) - h(r)\}, \end{aligned} \quad (5.18)$$

$$\begin{aligned} \mathcal{C}_{sf}^{out} &= \{(R_1, R_2) : R_1 \leq 2 - h(p) - h(q), R_2 \leq 2 - h(p) - h(r), \\ &R_1 + R_2 \leq 3 - h(p) - h(q) - h(r)\}, \end{aligned} \quad (5.19)$$

$$\mathcal{C}_s^{in} = \{(R_1, R_2) : R_1 \leq 1 - h(q), R_2 \leq 1 - h(r)\}. \quad (5.20)$$

Figure 9 depicts  $\mathcal{C}_{sf}^{in-1}$ ,  $\mathcal{C}_{sf}^{in-2}$ ,  $\mathcal{C}_{sf}^{out}$  and  $\mathcal{C}_s^{in}$  for  $p = q = r = 0.05$ . It is easy to see that for the case  $Z_1 \rightarrow Z_0 \rightarrow Z_2$ , the hybrid feedback strategy performs better than the secret key based feedback strategy, and both of these strategies increase the secrecy rate region of the BC-MSR. Also notice that there is a gap between the inner and outer bounds.

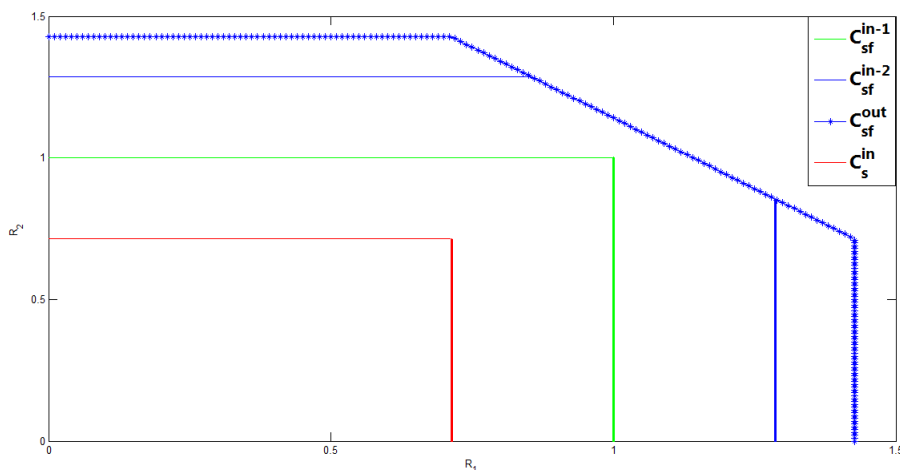

Fig. 9: Comparison of the bounds for the case  $Z_1 \rightarrow Z_0 \rightarrow Z_2$  and  $p = q = r = 0.05$

Figure 10 plots  $C_{sf}^{in-1}$ ,  $C_{sf}^{in-2}$ ,  $C_{sf}^{out}$  and  $C_s^{in}$  for  $p = 0.25$ ,  $q = 0.2$  and  $r = 0.3$ . From Figure 10, we conclude that for this case, the secrecy capacity region of the BC-MSR with noiseless feedback is determined, and it equals to the inner bounds  $C_{sf}^{in-1}$ ,  $C_{sf}^{in-2}$ , and the outer bound  $C_{sf}^{out}$ . Also, we see that for this case, the secret key based feedback strategy performs as well as the hybrid feedback coding strategy, and both of them increase the secrecy rate region of the BC-MSR.

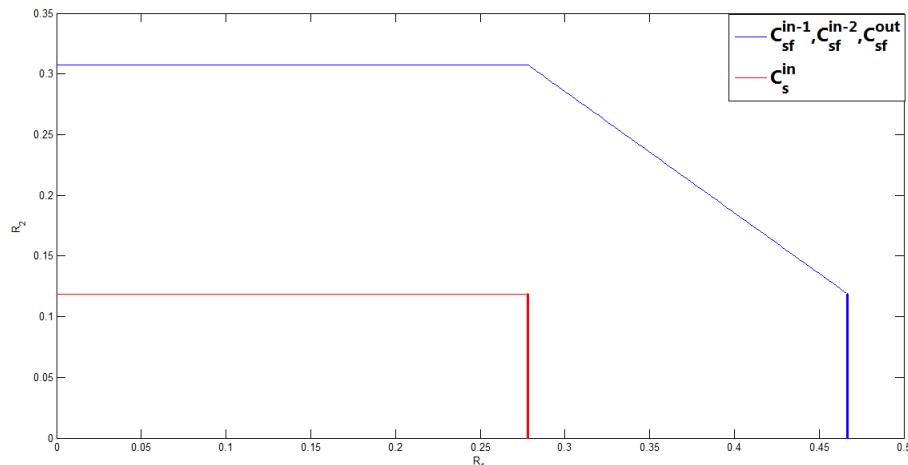

Fig. 10: Comparison of the bounds for the case  $Z_1 \rightarrow Z_0 \rightarrow Z_2$  and  $p = 0.25$ ,  $q = 0.2$ ,  $r = 0.3$

### B. Blackwell-type Example

In this subsection, we explain the inner and outer bounds on the secrecy capacity region of the BC-MSR with noiseless feedback via a Blackwell-type example. In this example (see Figure 11), the channel input  $X$  chooses values from  $\{0, 1, 2\}$ , the channel outputs  $Y_1$  and  $Y_2$  choose values from  $\{0, 1\}$ , and they satisfy

$$\left\{ \begin{array}{l} X = 0, \quad Y_1 = Z_1, \quad Y_2 = Z_2, \\ X = 1, \quad Y_1 = 1 \oplus Z_1, \quad Y_2 = Z_2, \\ X = 2, \quad Y_1 = 1 \oplus Z_1, \quad Y_2 = 1 \oplus Z_2, \end{array} \right\}, \quad (5.21)$$

where  $\oplus$  is the modulo addition over  $\{0, 1\}$ , the noises  $Z_1 \sim \text{Bern}(p)$ ,  $Z_2 \sim \text{Bern}(p)$  ( $0 \leq p \leq 0.5$ ), and the noises  $Z_1, Z_2$  are mutually independent and they are independent of the channel inputs.

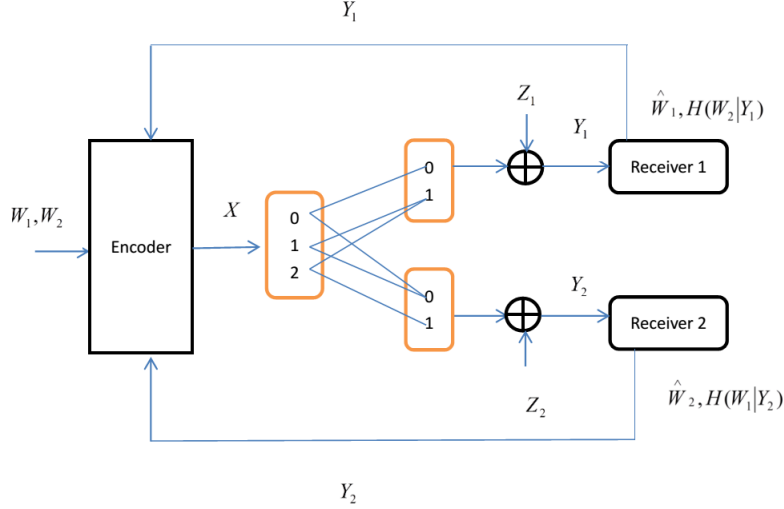

Fig. 11: A Blackwell-type example of the BC-MSR with noiseless feedback

For this Blackwell-type example, the secret key based inner bound  $\mathcal{C}_s^{f-in-1*}$  is obtained by defining  $P(Q = 0) = P(Q = 1) = \frac{1}{2}$ ,

$$\begin{aligned}
 P(U_1 = 0, U_2 = 0|Q = 0) &= \alpha, P(U_1 = 0, U_2 = 1|Q = 0) = 0, \\
 P(U_1 = 1, U_2 = 0|Q = 0) &= 1 - \alpha - \beta, P(U_1 = 1, U_2 = 1|Q = 0) = \beta, \\
 P(U_1 = 0, U_2 = 0|Q = 1) &= \beta, P(U_1 = 0, U_2 = 1|Q = 1) = 0, \\
 P(U_1 = 1, U_2 = 0|Q = 1) &= 1 - \alpha - \beta, P(U_1 = 1, U_2 = 1|Q = 1) = \alpha,
 \end{aligned} \tag{5.22}$$

$X = U_1 + U_2$ , and substituting (5.21),  $Z_1 \sim \text{Bern}(p)$  and  $Z_2 \sim \text{Bern}(p)$  into Theorem 3. Hence we have

$$\begin{aligned}
 \mathcal{C}_s^{f-in-1*} &= \{(R_1, R_2) : \\
 R_1 &\leq \frac{1}{2}h(\alpha \star p) + \frac{1}{2}h(\beta \star p) - (1 - \beta) \log \frac{1}{1 - \beta} - (1 - \alpha) \log \frac{1}{1 - \alpha} + (1 - \alpha - \beta) \log \frac{1}{1 - \alpha - \beta}, \\
 R_2 &\leq \frac{1}{2}h(\alpha \star p) + \frac{1}{2}h(\beta \star p) - (1 - \beta) \log \frac{1}{1 - \beta} - (1 - \alpha) \log \frac{1}{1 - \alpha} + (1 - \alpha - \beta) \log \frac{1}{1 - \alpha - \beta}, \\
 R_1 &\leq \frac{1}{2}h(\alpha \star p) + \frac{1}{2}h(\beta \star p) - h(p), \\
 R_2 &\leq \frac{1}{2}h(\alpha \star p) + \frac{1}{2}h(\beta \star p) - h(p), \\
 R_1 + R_2 &\leq h(\alpha \star p) + h(\beta \star p) - (1 - \beta) \log \frac{1}{1 - \beta} - (1 - \alpha) \log \frac{1}{1 - \alpha} + (1 - \alpha - \beta) \log \frac{1}{1 - \alpha - \beta} \},
 \end{aligned}$$

(5.23)

where  $a \star b = a(1 - b) + (1 - a)b$  and  $h(a) = -a \log(a) - (1 - a) \log(1 - a)$  ( $0 \leq a \leq 1$ ).

Then, using the above definitions for  $\mathcal{C}_s^{f-in-1*}$  and letting  $V_0 = Z$ ,  $V_1 = U_1$ ,  $V_2 = U_2$ , the hybrid inner bound  $\mathcal{C}_s^{f-in-2*}$  is obtained by substituting (5.21),  $Z_1 \sim \text{Bern}(p)$  and  $Z_2 \sim \text{Bern}(p)$  into Theorem 2, and it is given by

$$\begin{aligned}
\mathcal{C}_s^{f-in-2*} &= \{(R_1, R_2) : \\
R_1 &\leq \min\{\frac{1}{2}h(\alpha) + \frac{1}{2}h(\beta), h(\alpha, \beta, 1 - \alpha - \beta) - \frac{1}{2}h(\alpha) - \frac{1}{2}h(\beta) + h(p)\}, \\
R_2 &\leq \min\{\frac{1}{2}h(\alpha) + \frac{1}{2}h(\beta), h(\alpha, \beta, 1 - \alpha - \beta) - \frac{1}{2}h(\alpha) - \frac{1}{2}h(\beta) + h(p)\}, \\
R_1 &\leq h(\frac{\alpha + \beta}{2} \star p) - 2h(p), \quad R_2 \leq h(\frac{\alpha + \beta}{2} \star (1 - p)) - 2h(p) \\
R_1 + R_2 &\leq h(\frac{\alpha + \beta}{2} \star p) - 2h(p) - \frac{1}{2}h(\alpha) - \frac{1}{2}h(\beta) + h(\alpha, \beta, 1 - \alpha - \beta)\},
\end{aligned} \tag{5.24}$$

where  $h(\alpha, \beta, 1 - \alpha - \beta) = -\alpha \log(\alpha) - \beta \log(\beta) - (1 - \alpha - \beta) \log(1 - \alpha - \beta)$ .

Next, we show an outer bound  $\mathcal{C}_s^{f-out*}$  on the secrecy capacity region of this Blackwell-type example, and it is obtained from Theorem 4. Specifically, the bound  $R_1 \leq \min\{I(U_1; Y_1|Q) - I(U_1; Y_2|Q), I(U_1; Y_1|Q, U_2) - I(U_1; Y_2|Q, U_2), H(Y_1|Q, U_2, Y_2)\}$  in Theorem 4 can be further bounded by

$$\begin{aligned}
&I(U_1; Y_1|Q) - I(U_1; Y_2|Q) \\
&\leq I(U_1; Y_1|Q) \leq H(Y_1) - H(Y_1|Q, U_1) \\
&\leq H(Y_1) - H(Y_1|Q, U_1, X) \stackrel{(1)}{=} H(Y_1) - H(Y_1|X) = I(X; Y_1),
\end{aligned} \tag{5.25}$$

$$\begin{aligned}
&I(U_1; Y_1|Q, U_2) - I(U_1; Y_2|Q, U_2) \\
&\leq I(U_1; Y_1|Q, U_2) \leq H(Y_1) - H(Y_1|Q, U_1, U_2) \\
&\leq H(Y_1) - H(Y_1|Q, U_1, U_2, X) \stackrel{(2)}{=} H(Y_1) - H(Y_1|X) = I(X; Y_1),
\end{aligned} \tag{5.26}$$

$$H(Y_1|Q, U_2, Y_2) \leq H(Y_1|Y_2), \tag{5.27}$$

where (1) is from  $(Q, U_1) \rightarrow X \rightarrow Y_1$ , and (2) is from  $(Q, U_1, U_2) \rightarrow X \rightarrow Y_1$ . Hence we have  $R_1 \leq \min\{I(X; Y_1), H(Y_1|Y_2)\}$ . Analogously, we have  $R_2 \leq \min\{I(X; Y_2), H(Y_2|Y_1)\}$ . Now defining

$$P(X = 0) = \alpha_1, \quad P(X = 1) = \alpha_2, \quad P(X = 2) = 1 - \alpha_1 - \alpha_2, \tag{5.28}$$



and substituting (5.21),  $Z_1 \sim \text{Bern}(p)$  and  $Z_2 \sim \text{Bern}(p)$  into  $R_1 \leq \min\{I(X; Y_1), H(Y_1|Y_2)\}$  and  $R_2 \leq \min\{I(X; Y_2), H(Y_2|Y_1)\}$ , the outer bound  $\mathcal{C}_s^{f-out*}$  is given by

$$\begin{aligned} \mathcal{C}_s^{f-out*} &= \{(R_1, R_2) : \\ R_1 &\leq \min\{h(\alpha_1 \star p) - h(p), A - h(\alpha_1 + \alpha_2) \star p\}, \\ R_2 &\leq \min\{h((\alpha_1 + \alpha_2) \star p) - h(p), A - h(\alpha_1 \star p)\}, \end{aligned} \quad (5.29)$$

where

$$\begin{aligned} A &= -(\alpha_1 \bar{p}^2 + \alpha_2 p \bar{p} + \overline{\alpha_1 + \alpha_2 p^2}) \log(\alpha_1 \bar{p}^2 + \alpha_2 p \bar{p} + \overline{\alpha_1 + \alpha_2 p^2}) \\ &\quad -(\alpha_1 \bar{p} p + \alpha_2 p^2 + \overline{\alpha_1 + \alpha_2 p \bar{p}}) \log(\alpha_1 \bar{p} p + \alpha_2 p^2 + \overline{\alpha_1 + \alpha_2 p \bar{p}}) \\ &\quad -(\alpha_1 \bar{p} p + \alpha_2 \bar{p}^2 + \overline{\alpha_1 + \alpha_2 p \bar{p}}) \log(\alpha_1 \bar{p} p + \alpha_2 \bar{p}^2 + \overline{\alpha_1 + \alpha_2 p \bar{p}}) \\ &\quad -(\alpha_1 p^2 + \alpha_2 p \bar{p} + \overline{\alpha_1 + \alpha_2 \bar{p}^2}) \log(\alpha_1 p^2 + \alpha_2 p \bar{p} + \overline{\alpha_1 + \alpha_2 \bar{p}^2}), \end{aligned} \quad (5.30)$$

$\bar{p} = 1 - p$  and  $\overline{\alpha_1 + \alpha_2} = 1 - \alpha_1 - \alpha_2$ .

Finally, we show the inner bound  $\mathcal{C}_s^{in**}$  on the secrecy capacity region of this Blackwell-type example without the feedback, and it is obtained by using the above definitions for  $\mathcal{C}_s^{f-in-1*}$  and substituting (5.21),  $Z_1 \sim \text{Bern}(p)$  and  $Z_2 \sim \text{Bern}(p)$  into (5.9). Hence we have

$$\begin{aligned} \mathcal{C}_s^{in**} &= \{(R_1, R_2) : \\ R_1 &\leq \frac{1}{2}h(\alpha \star p) + \frac{1}{2}h(\beta \star p) - h(p) - \bar{\beta} \log \frac{1}{\bar{\beta}} - \bar{\alpha} \log \frac{1}{\bar{\alpha}} - \overline{\alpha + \beta} \log \overline{\alpha + \beta}, \\ R_2 &\leq \frac{1}{2}h(\alpha \star p) + \frac{1}{2}h(\beta \star p) - h(p) - \bar{\beta} \log \frac{1}{\bar{\beta}} - \bar{\alpha} \log \frac{1}{\bar{\alpha}} - \overline{\alpha + \beta} \log \overline{\alpha + \beta}\}, \end{aligned} \quad (5.31)$$

where  $\bar{\beta} = 1 - \beta$ ,  $\bar{\alpha} = 1 - \alpha$  and  $\overline{\alpha + \beta} = 1 - \alpha - \beta$ .

To show which feedback strategy performs better in enhancing the total secrecy rate of the BC-MSR, in this Blackwell-type example, we depict the secrecy sum rates of the bounds  $\mathcal{C}_s^{f-in-1*}$ ,  $\mathcal{C}_s^{f-in-2*}$ ,  $\mathcal{C}_s^{f-out*}$  and  $\mathcal{C}_s^{in**}$  with different values of  $p$  (here  $p$  is w.r.t. the channel noise), see Figure 12. From Figure 12, we see that both feedback strategies increase the secrecy sum rate of  $\mathcal{C}_s^{in**}$ , and the hybrid feedback strategy does not always perform better than the secret key based feedback strategy in enhancing the secrecy sum rate of this Blackwell-type BC-MSR. Moreover, as shown in Figure 12, there exists a gap between the secrecy sum rates of the inner and outer bounds, and eliminating this gap is still a tough work.

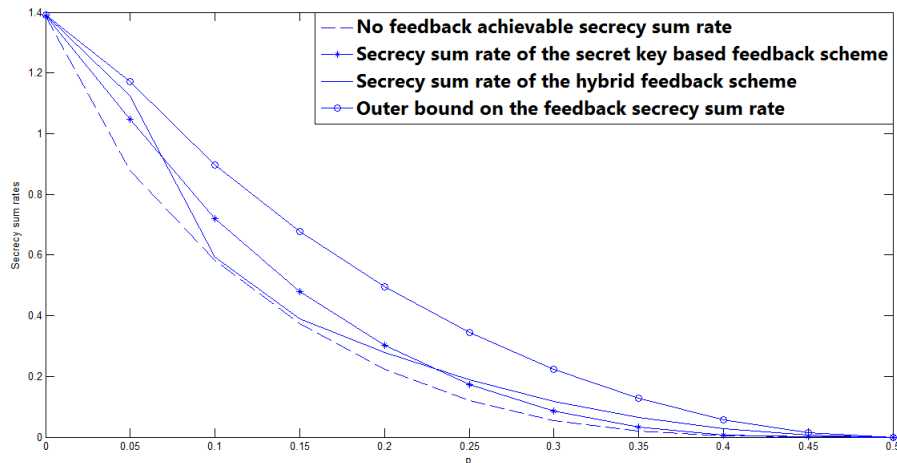

Fig. 12: The maximum secrecy sum rates of the bounds for the Blackwell-type example of the BC-MSR with noiseless feedback

## VI. CONCLUSION

Two feedback coding strategies for the BC-MSR are proposed, and the comparison of the two strategies is shown via two examples. Specifically, in the Dueck-type example, we show the achievable secrecy rate region of the secret key based feedback strategy is no larger than that of the hybrid feedback strategy. For the Blackwell-type example, we show the secrecy sum rate of the hybrid feedback strategy is not always larger than that of the secret key based feedback strategy. From these two examples, we see that for the BC-MSR, our new hybrid feedback strategy may perform better than the already existing secret key based feedback strategy, which offers a new option for enhancing the physical layer security of the broadcast channel models.

## APPENDIX A

### PROOF OF THEOREM 4

First, define  $Y_1^{i-1} = (Y_{1,1}, Y_{1,2}, \dots, Y_{1,i-1})$ ,  $Y_{1,i+1}^N = (Y_{1,i+1}, Y_{1,i+2}, \dots, Y_{1,N})$ ,  $Y_2^{i-1} = (Y_{2,1}, Y_{2,2}, \dots, Y_{2,i-1})$  and  $Y_{2,i+1}^N = (Y_{2,i+1}, Y_{2,i+2}, \dots, Y_{2,N})$ . Further define

$$Q \triangleq (Y_1^{L-1}, Y_{2,L+1}^N, L), U_1 \triangleq (Q, W_1), U_2 \triangleq (Q, W_2), Y_1 \triangleq Y_{1,L}, Y_2 \triangleq Y_{2,L}, \quad (\text{A1})$$

where the RV  $L$  is used for time sharing, and it is randomly drawn from the set  $\{1, 2, \dots, N\}$ . In addition,  $L$  is independent of the channel input and outputs.

Next, using the above definitions, we show that  $R_1$  can be upper bounded by

$$\begin{aligned}
R_1 - \epsilon &\stackrel{(1)}{\leq} \frac{1}{N} H(W_1|Y_2^N) \\
&= \frac{1}{N} (H(W_1|Y_2^N, W_2) + I(W_1; W_2|Y_2^N)) \\
&\stackrel{(2)}{\leq} \frac{1}{N} H(W_1|Y_2^N, W_2) + \frac{\delta(\epsilon)}{N} \\
&= \frac{1}{N} (H(W_1|W_2) - I(W_1; Y_2^N|W_2)) + \frac{\delta(\epsilon)}{N} \\
&\stackrel{(3)}{\leq} \frac{1}{N} (I(W_1; Y_1^N|W_2) - I(W_1; Y_2^N|W_2)) + \frac{2\delta(\epsilon)}{N} \\
&= \frac{1}{N} \sum_{i=1}^N (I(W_1; Y_{1,i}|Y_1^{i-1}, W_2) - I(W_1; Y_{2,i}|Y_{2,i+1}^N, W_2)) + \frac{2\delta(\epsilon)}{N} \\
&= \frac{1}{N} \sum_{i=1}^N (I(W_1; Y_{1,i}|Y_1^{i-1}, W_2, Y_{2,i+1}^N) + I(Y_{1,i}; Y_{2,i+1}^N|W_2, Y_1^{i-1}) - I(Y_{1,i}; Y_{2,i+1}^N|W_1, W_2, Y_1^{i-1}) \\
&\quad - I(W_1; Y_{2,i}|Y_1^{i-1}, W_2, Y_{2,i+1}^N) - I(Y_{2,i}; Y_1^{i-1}|W_2, Y_{2,i+1}^N) + I(Y_{2,i}; Y_1^{i-1}|W_1, W_2, Y_{2,i+1}^N)) + \frac{2\delta(\epsilon)}{N} \\
&\stackrel{(4)}{=} \frac{1}{N} \sum_{i=1}^N (I(W_1; Y_{1,i}|Y_1^{i-1}, W_2, Y_{2,i+1}^N) - I(W_1; Y_{2,i}|Y_1^{i-1}, W_2, Y_{2,i+1}^N)) + \frac{2\delta(\epsilon)}{N} \\
&\stackrel{(5)}{=} I(W_1; Y_{1,L}|Y_1^{L-1}, W_2, Y_{2,L+1}^N, L) - I(W_1; Y_{2,L}|Y_1^{L-1}, W_2, Y_{2,L+1}^N, L) + \frac{2\delta(\epsilon)}{N} \\
&\stackrel{(6)}{=} I(U_1; Y_1|U_2, Q) - I(U_1; Y_2|U_2, Q) + \frac{2\delta(\epsilon)}{N}, \tag{A2}
\end{aligned}$$

where (1) follows by (3.8), (2) and (3) follow by Fano's inequality,  $P_{e,1} \leq \epsilon$  and  $P_{e,2} \leq \epsilon$ , (4) is from the Csiszár's equalities

$$I(Y_{1,i}; Y_{2,i+1}^N|W_2, Y_1^{i-1}) = I(Y_{2,i}; Y_1^{i-1}|W_2, Y_{2,i+1}^N), \tag{A3}$$

and

$$I(Y_{1,i}; Y_{2,i+1}^N|W_1, W_2, Y_1^{i-1}) = I(Y_{2,i}; Y_1^{i-1}|W_1, W_2, Y_{2,i+1}^N), \tag{A4}$$

(5) follows by the definition of  $J$ , and (6) follows by (A1). Letting  $\epsilon \rightarrow 0$ , we get  $R_1 \leq I(U_1; Y_1|U_2, Q) - I(U_1; Y_2|U_2, Q)$ .

Moreover, note that

$$\begin{aligned}
R_1 - \epsilon &\leq \frac{1}{N} H(W_1|Y_2^N) \\
&= \frac{1}{N} (H(W_1) - I(W_1; Y_2^N)) \\
&\stackrel{(a)}{\leq} \frac{1}{N} (I(W_1; Y_1^N) - I(W_1; Y_2^N)) + \frac{\delta(\epsilon)}{N} \\
&= \frac{1}{N} \sum_{i=1}^N (I(W_1; Y_{1,i}|Y_1^{i-1}) - I(W_1; Y_{2,i}|Y_{2,i+1}^N)) + \frac{\delta(\epsilon)}{N} \\
&= \frac{1}{N} \sum_{i=1}^N (I(W_1; Y_{1,i}|Y_1^{i-1}, Y_{2,i+1}^N) + I(Y_{1,i}; Y_{2,i+1}^N|Y_1^{i-1}) - I(Y_{1,i}; Y_{2,i+1}^N|W_1, Y_1^{i-1}) \\
&\quad - I(W_1; Y_{2,i}|Y_1^{i-1}, Y_{2,i+1}^N) - I(Y_{2,i}; Y_1^{i-1}|Y_{2,i+1}^N) + I(Y_{2,i}; Y_1^{i-1}|W_1, Y_{2,i+1}^N)) + \frac{\delta(\epsilon)}{N} \\
&\stackrel{(b)}{=} \frac{1}{N} \sum_{i=1}^N (I(W_1; Y_{1,i}|Y_1^{i-1}, Y_{2,i+1}^N) - I(W_1; Y_{2,i}|Y_1^{i-1}, Y_{2,i+1}^N)) + \frac{\delta(\epsilon)}{N} \\
&\stackrel{(c)}{=} I(W_1; Y_{1,L}|Y_1^{L-1}, Y_{2,L+1}^N, L) - I(W_1; Y_{2,L}|Y_1^{L-1}, Y_{2,L+1}^N, L) + \frac{\delta(\epsilon)}{N} \\
&\stackrel{(d)}{=} I(U_1; Y_1|Q) - I(U_1; Y_2|Q) + \frac{\delta(\epsilon)}{N}, \tag{A5}
\end{aligned}$$

where (a) follows by Fano's inequality and  $P_{e,1} \leq \epsilon$ , (b) follows from the similar Csiszár's equalities of (A3) and (A4), (c) follows by the definition of  $J$ , and (d) follows by (A1). Letting  $\epsilon \rightarrow 0$ , we get  $R_1 \leq I(U_1; Y_1|Q) - I(U_1; Y_2|Q)$ .

Finally, notice that

$$\begin{aligned}
R_1 - \epsilon &\leq \frac{1}{N} H(W_1|Y_2^N) \\
&= \frac{1}{N} (H(W_1|Y_2^N, W_2) + I(W_1; W_2|Y_2^N)) \\
&\leq \frac{1}{N} H(W_1|Y_2^N, W_2) + \frac{\delta(\epsilon)}{N} \\
&= \frac{1}{N} (H(W_1|Y_2^N, W_2) - H(W_1|Y_2^N, W_2, Y_1^N) + H(W_1|Y_2^N, W_2, Y_1^N)) + \frac{\delta(\epsilon)}{N} \\
&\stackrel{(e)}{\leq} \frac{1}{N} I(W_1; Y_1^N|Y_2^N, W_2) + \frac{2\delta(\epsilon)}{N} \\
&\leq \frac{1}{N} H(Y_1^N|Y_2^N, W_2) + \frac{2\delta(\epsilon)}{N} \\
&= \frac{1}{N} \sum_{i=1}^N H(Y_{1,i}|Y_1^{i-1}, Y_2^N, W_2) + \frac{2\delta(\epsilon)}{N}
\end{aligned}$$

$$\begin{aligned}
&\leq \frac{1}{N} \sum_{i=1}^N H(Y_{1,i}|Y_1^{i-1}, Y_{2,i+1}^N, Y_{2,i}, W_2) + \frac{2\delta(\epsilon)}{N} \\
&\stackrel{(f)}{=} H(Y_{1,L}|Y_1^{L-1}, Y_{2,L+1}^N, Y_{2,L}, W_2, L) + \frac{2\delta(\epsilon)}{N} \\
&\stackrel{(g)}{=} H(Y_1|Q, U_2, Y_2) + \frac{2\delta(\epsilon)}{N}, \tag{A6}
\end{aligned}$$

where (e) follows by Fano's inequality, (f) follows by the definition of  $J$ , and (g) follows by (A1). Letting  $\epsilon \rightarrow 0$ , we get  $R_1 \leq H(Y_1|Q, U_2, Y_2)$ . Now the proof of  $R_1 \leq \min\{I(U_1; Y_1|Q) - I(U_1; Y_2|Q), I(U_1; Y_1|Q, U_2) - I(U_1; Y_2|Q, U_2), H(Y_1|Q, U_2, Y_2)\}$  is completed. Analogously, we can prove  $R_2 \leq \min\{I(U_2; Y_2|Q) - I(U_2; Y_1|Q), I(U_2; Y_2|Q, U_1) - I(U_2; Y_1|Q, U_1), H(Y_2|Q, U_1, Y_1)\}$ . The proof of Theorem 4 is completed.

## REFERENCES

- [1] A. D. Wyner, "The wire-tap channel," *The Bell System Technical Journal*, vol. 54, no. 8, pp. 1355-1387, 1975.
- [2] I. Csiszár and J. Körner, "Broadcast channels with confidential messages," *IEEE Trans. Inf. Theory*, vol. IT-24, no. 3, pp. 339-348, May 1978.
- [3] E. Tekin and A. Yener, "The Gaussian multiple access wire-tap channel," *IEEE Trans Inf Theory*, vol. IT-54, no. 12, pp. 5747-5755, Dec. 2008.
- [4] B. Dai and Z. Ma, "Multiple-access relay wiretap channel," *IEEE Trans. Inf. Forensics and Security*, vol. 10, no. 9, pp. 1835-1849, Dec. 2015.
- [5] L. Lai and H. El Gamal, "The relay-eavesdropper channel: cooperation for secrecy," *IEEE Trans Inf Theory*, vol. IT-54, no. 9, pp. 4005C4019, Sep. 2008.
- [6] Y. Oohama, "Coding for relay channels with confidential messages," in *Proceedings of IEEE Information Theory Workshop*, Australia, 2001.
- [7] E. Ekrem, S. Ulukus, "Secrecy capacity of a class of broadcast channels with an eavesdropper," *EURASIP Journal on Wireless Communications and Networking*, vol. 2009, no. 1, pp. 1-29, 2009.
- [8] G. Bagherikaram, A. S. Motahari, and A. K. Khandani, "The secrecy rate region of the broadcast channel," *Proceedings of the Allerton Conference on Communications, Control and Computing*, 2008.
- [9] E. Tekin and A. Yener, "The general Gaussian multiple access and two-way wire-tap channels: Achievable rates and cooperative jamming," *IEEE Trans Inf Theory*, vol. IT-54, no. 6, pp. 2735-2751, June 2008.
- [10] A. El Gamal, O. O. Koyluoglu, M. Youssef and H. El Gamal, "Achievable secrecy rate regions for the two-way wiretap channel," *IEEE Trans Inf Theory*, vol. IT-59, no. 12, pp. 8099-8114, 2013.
- [11] Y. Liang and H. V. Poor, "Multiple-access channels with confidential messages," *IEEE Trans Inf Theory*, vol. IT-54, no. 3, pp. 976-1002, Mar. 2008.
- [12] R. Liu, I. Maric, P. Spasojević and R.D Yates, "Discrete memoryless interference and broadcast channels with confidential messages: secrecy rate regions," *IEEE Trans Inf Theory*, vol. IT-54, no. 6, pp. 2493-2507, Jun. 2008.
- [13] J. Xu, Y. Cao, and B. Chen, "Capacity bounds for broadcast channels with confidential messages," *IEEE Trans Inf Theory*, vol. IT-55, no. 6, pp. 4529-4542. 2009.

- [14] E. Ekrem and S. Ulukus, "Secrecy in cooperative relay broadcast channels," *IEEE Trans Inf Theory*, vol. IT-57, pp. 137-155, 2011.
- [15] B. Dai, L. Yu and Z. Ma, "Relay broadcast channel with confidential messages," *IEEE Trans. Inf. Forensics and Security*, vol. 11, no. 2, pp. 410-425, Dec. 2016.
- [16] R. Ahlswede and N. Cai, "Transmission, Identification and Common Randomness Capacities for Wire-Tap Channels with Secure Feedback from the Decoder," book chapter in *General Theory of Information Transfer and Combinatorics*, LNCS 4123, pp. 258-275, Berlin: Springer-Verlag, 2006.
- [17] E. Ardestanizadeh, M. Franceschetti, T. Javidi and Y. Kim, "Wiretap channel with secure rate-limited feedback," *IEEE Trans. Inf. Theory*, vol. IT-55, no. 12, pp. 5353-5361, December 2009.
- [18] R. F. Schaefer, A. Khisti and H. V. Poor, "Secure broadcasting using independent secret keys," *IEEE Transactions on Communications*, accepted, DOI 10.1109/TCOMM.2017.2764892.
- [19] A. Cohen, A. Cohen, "Wiretap channel with causal state information and secure rate-limited feedback," *IEEE Trans. Communications*, vol. 64, no. 3, pp. 1192-1203, 2016.
- [20] B. Dai, Z. Ma and X. Fang, "Feedback enhances the security of state-dependent degraded broadcast channels with confidential messages," *IEEE Trans. Inf. Forensics and Security*, Vol. 10, No. 7, pp. 1529-1542, 2015.
- [21] B. Dai, Z. Ma and Y. Luo, "Finite state Markov wiretap channel with delayed feedback," *IEEE Trans. Inf. Forensics and Security*, Vol. 12, No. 3, pp. 746-760, 2017.
- [22] K. Marton, "A coding theorem for the discrete memoryless broadcast channel," *IEEE Trans. Inf. Theory*, vol. 25, no. 3, pp. 306-311, May 1979.
- [23] A. El Gamal and Y. Kim, *Network information theory*. Cambridge University Press, 2011.
- [24] R. Timo, A. Grant, T. Chan and G. Kramer, "Source coding for a simple network with receiver side information," in *Proc. Int. Symp. Inf. Theory, Toronto, Canada*, Jul. 6-11, 2008, pp. 2307-2311.